

WINCO®

WL22000VE

19,000 RUNNING WATTS

Rugged Steel Design



B & S Commercial Vanguard Engine

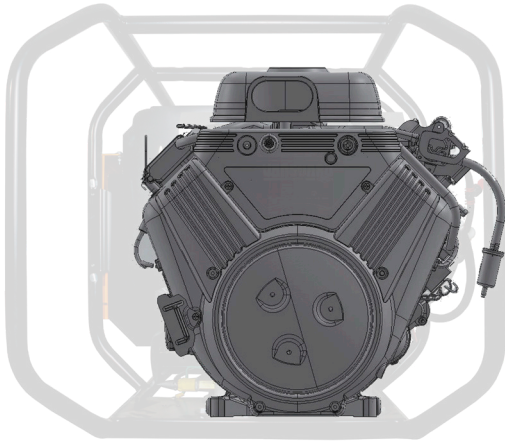

Brushless Industrial Genend

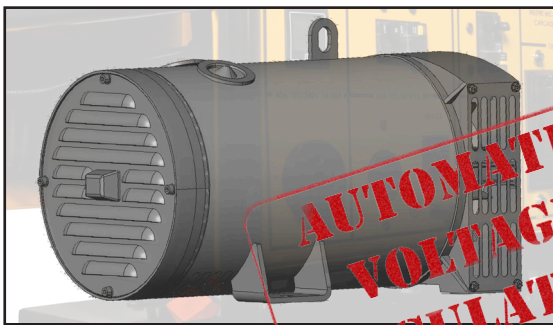

**AUTOMATIC
VOLTAGE
REGULATION**

YOURGEN

LED Display
Hours, RPMs, voltage,
and frequency readings
automatically cycle on the display.



Load Bars
Easily verify the load balance
on each leg of the generator end.



Warnings
The LED will flash if any parameter
gets outside of normal range. A
warning will also be displayed
when it is time for an oil change.



Receptacle Panel
with GFCI protection

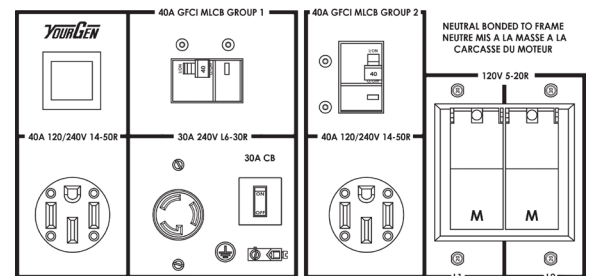

SPECIFICATIONS

WL22000VE

ENGINE

ENGINE BRAND	BRIGGS & STRATTON
ENGINE MODEL	VANGUARD
ENGINE STARTER	ELECTRIC
ENGINE SPEED	3600 RPM
ENGINE CYLINDERS	V-TWIN
DISPLACEMENT/TYPE	993 CC / OHV
FREQUENCY REGULATION ⁽¹⁾	+/-1.5%
LOW OIL PROTECTION	STANDARD
RECOMMENDED OIL ⁽²⁾	10W-30
OIL CAPACITY	2.3 QT
FUEL TANK	15 GAL
FUEL GAUGE	YES
FULL LOAD RUN TIME ⁽³⁾	4.5 HOURS
FUEL CONSUMPTION	GAL/HR
100%	3.28
75%	2.57
50%	1.88
25%	1.43
0%	0.95
BATTERY SIZE ⁽⁴⁾	BCI GROUP 26 500CCA

NOTES: (1) Steady state frequency regulation. (2) The recommended oil is for normal applications. See operator's manual for the recommended oil for your needs. (3) Run time is estimated. (4) Battery not included.

OPTIONAL ACCESSORIES

FOUR-WHEEL DOLLY KIT	WITH FLAT-FREE TIRES
BATTERY	BCI GROUP 26 500 CCA
MAINTENANCE KIT	16200-011

ELECTRICAL

STARTING WATTS	22,000
RUNNING WATTS	19,000
RUNNING AMPS @ 120 VAC	158.3
RUNNING AMPS @ 240 VAC	79.2
VOLTAGE REGULATION	AVR +/- 1.5%
MAIN CIRCUIT BREAKER	(2) 40 AMP, 240V (GFCI)
BONDED NEUTRAL	YES
120 VOLT RECEPTACLES	(4) NEMA 5-20 20A (GFCI)
120/240 VOLT RECEPTACLES	(2) 14-50R 50A (GFCI)
240 VOLT RECEPTACLE	(1) NEMA L6-30 30A (GFCI)
YOURGEN METER	STANDARD

GENSET

MOTOR STARTING (CODE G)	6 HP
DBA @ 7 METERS	79
TOTAL HARMONIC DISTORTION	< 6%
LIFTING EYE ⁽¹⁾	STANDARD
4-WHEEL DOLLY KIT	OPTIONAL
INSULATION	CLASS H
PROTECTIVE ROLL FRAME	1.25" DIA. 14 GA. STEEL
ASSEMBLED IN	USA
EPA APPROVED	YES
CARB APPROVED	NO
CSA APPROVED	NO
UNIT WARRANTY ⁽²⁾	3 YEARS COMMERCIAL

NOTES: (1) Shipping eye shipped loose. (2) For more generator warranty, see operator's manual.

SHIPPING

SHIPPING DIMENSIONS (L x W x H)	43.5" x 31" x 37"
SHIP WEIGHT	504 LBS
FREIGHT CLASS	70

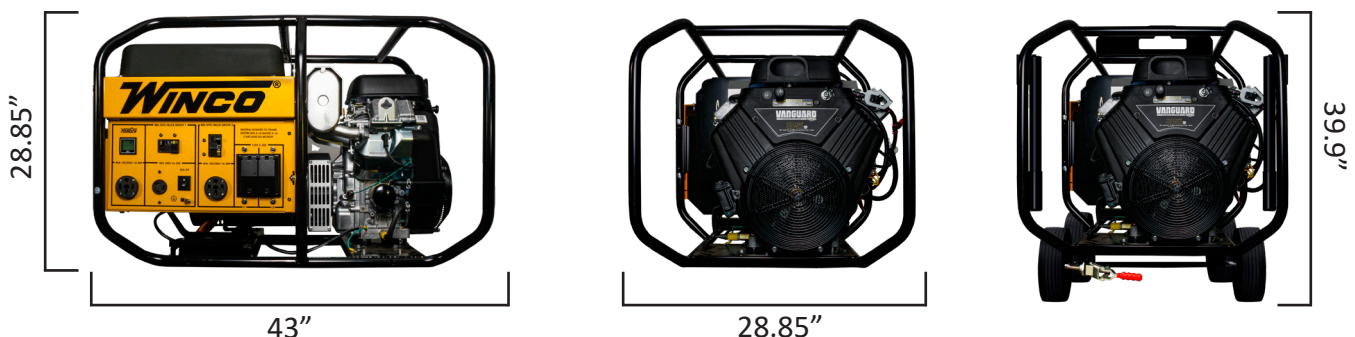

Specifications are subject to change without notice.

225 S. Cordova Ave Le Center MN • 1-800-733-2112
www.wincogen.com