

# WHITE-RODGERS WHOLESALE CATALOG

2025



sensi  
by COPELAND

WHITE-RODGERS  
by COPELAND

# Contact Information

## Main Office:

**Phone:** (314)-553-3600

**Address:** 8100 W Florissant Ave, St. Louis, MO 63136-9022

**Fax:** 800-274-9797

**Customer & Tech Service:** (888)-725-9797

**Sensi Support:** (888)-605-7131

**Email:** [WR.wholesale.mail@copeland.com](mailto:WR.wholesale.mail@copeland.com)

## Websites:

**Main Site:** [www.copeland.com/white-rodgers.com](http://www.copeland.com/white-rodgers.com)

**Sensi:** [sensi.copeland.com](http://sensi.copeland.com)

**Cross Reference:** [wrcrossref.com](http://wrcrossref.com)

**Pro Branding:** [procontractorbranding.com](http://procontractorbranding.com)

**Sensi Partner:** [sensipartnerprogram.com](http://sensipartnerprogram.com)

**Contractor Rewards:** [copeland.com/contractorrewards](http://copeland.com/contractorrewards)

**Wholesaler Resources:** [copeland.com/wrresources](http://copeland.com/wrresources)

## Canada Office:

**Address:** 145 Sherwood Dr, Brantford, ON, N3T 1N8

**Phone:** (519) 756-6157

**Email:** [wrsales.canada@copeland.com](mailto:wrsales.canada@copeland.com)

<b>Thermostats</b>	
Sensi Lite smart thermostat	1
Sensi Touch 2 smart thermostat	2
Sensi Touch smart thermostat	3
Sensi smart thermostat	4
Sensi room sensors	5
Sensi wireless outdoor sensor	6
Sensi Equipment Interface Module (indoor + outdoor)	7
Blue Series 12" touchscreen thermostats	8
Blue Series 6" thermostats	9
Blue Series 2" thermostats	10
80 Series thermostats	11
Classic 80 Series thermostats	12
70 Series thermostats	13
Classic 70 Series thermostats	14
Standard mechanical thermostats	15
Economy mechanical thermostats	16
1E65 line voltage digital thermostats	17
Line voltage baseboard thermostats - hydraulic	18
Line voltage baseboard thermostats - bimetal	19
Light & heavy duty line voltage thermostats	20
1A11-2 fan coil thermostat	21
Line voltage steel case thermostats for heating & cooling	21
Remote sensors for 24V Thermostats	22
Thermostat guards - plastic	23
Thermostat guards - metal	24
Thermostat parts and accessories	25
<b>Electronic furnace controls</b>	
Universal Integrated Furnace Controls	26
Direct OEM Replacement Integrated Furnace Controls	27
Non-Integrated Ignition Modules	28
Air Handler and Time Delay Controls	29
Universal Furnace Electronic Fan Timer	29
Commercial rooftop and package unit	30
<b>Gas valves</b>	
36C Series Universal Standing Pilot	31
36C Series HSI / DSI / Intermittent / Proven Pilot	33
36C Cycle Pilot Gas Valves	34
36H Series HSI / DSI / Intermittent / Proven Pilot	39
36G / J Series HSI / DSI / Intermittent / Proven Pilot	41
764 Gas Pilot Safety Fireplace Valves	44
25M Gas Dryer Valves & Coils	45
2500 Series Replacement Gas Valve Coils	45
<b>HSI ignitors</b>	
HotRod Series Universal Nitride Ignitor Upgrades	46

Direct OEM Replacement 80V and 120V Nitride Ignitors	47
Direct OEM Replacement 120V Carbide Ignitors	49
<b>Thermocouples / generators ignitors</b>	
H06 Series Universal 30 MV Thermocouples	52
750 MV Thermopile Generators	53
PG9 Series 750 MV Generators & Pilot Burners	53
<b>Flame sensors / electrodes</b>	
790 Series Universal Flame Sensor	54
790 Series Direct OEM Flame Sensors	54
Flame Sensors & Electrodes	55
Direct OEM Replacement Premium Pilot Burner Assembly	57
<b>Warm air fan controls / snap disc fan and limits</b>	
5D51 Series Plenum Mount Bimetal Fan & Limit Controls	58
Snap Disc Fixed Temperature Board Mount Limits	59
Snap Disc Manual Reset Flame Rollout Limits	63
Snap Disc Fixed Temperature Fan Limits	64
Snap Disc Adjustable Temperature Fan Limits	66
Snap Disc Automatic Reset Fan Limits	67
230-22 Fan Control	68
775-1 Attic Fan Control	69
770 Series Dual Purpose Air Switch	69
<b>Electric heat controls</b>	
24A34 Series Electric Heat Sequencers	70
Level-Temp Control for electric heat	72
<b>Water heater controls</b>	
750 Series Electric Water Heater Controls	73
37C Series Gas Hot Water Heater Controls	74
37E Series Intelli-Vent Controls	75
Integrated Water Heater Control	75
Gas Water Heater Control	76
<b>Hydronic zone valves</b>	
1300 Series Hydronic Zone Valves	77
Canada "Z" Series	80
Automatic Changeover Switch	81
1100 Series Well Immersion Temperature Controls	82
Immersion Wells & Packing Nuts	83
1100 Series Strap-On Style Temperature Controls	84
<b>Relays &amp; transformers</b>	
90-112 Thru 90-130 Fan Control Center	85
90-340 thru 90-342 Relays	86
8A05A Relay & Transformer Combinations	87
90-290Q thru 90-295Q Relays	88
90-360 thru 90-486 Relays	89

90-T Series Energy Limiting 24 VAC Transformers	90
S82 & S84 Energy Limiting 24 VAC Transformers	91
<b>D.C. power solenoids</b>	
Type 70 Series D.C. Power Solenoids	92
Type 120 Series D.C. Power Solenoids	93
Type 124 Series D.C. Power Solenoids	94
Type 586 Series D.C. Power Solenoids	95
<b>Media air cleaners</b>	
Media filter cross reference	96
<b>A/C &amp; defrost controls</b>	
Universal Heat Pump Defrost Control	97
A/C, Heat Pump and Demand Defrost Controls	97
<b>Contactors</b>	
SureSwitch Multi-Volt Universal Contactor	98
94 Series 1.5 Pole Mechanical Contactors	99
90 Series 2 Pole Mechanical Contactors	100
90 Series 3 Pole Mechanical Contactors	101
<b>Evaporative cooling</b>	
Evaporative Cooling Thermostat and Control	102
<b>Thermostatic expansion valves</b>	
Expansion valves quick selection guide	103
NXT Series Thermostatic Expansion Valves	104
NXT-R Series Thermostatic Expansion Valves	106
TXV Connect Kits Thermostatic Expansion Valves	111
HF Series Thermostatic Expansion Valves	112
TX7 Series Thermostatic Expansion Valves	122
TRAE Series Thermostatic Expansion Valves	124
T-Series Take-Apart Thermostatic Expansion Valves	127
TLE Series Thermostatic Expansion Valves	132
TI Series Thermostatic Expansion Valves	134
ZZ Series Thermostatic Expansion Valves	135
LCL Series Desuperheating Valves	137
<b>Thermostatic expansion valve capacity tables</b>	
Conventional ported valve capacity tables	140
Balanced ported valve capacity tables	154
<b>Electronic expansion valves and controls</b>	
EX4-EX8 Series Electrical Control Valves	194
EXD-SH1 & EXD-SH2 Series Temperature & Superheat Controllers & Kits	196
EXD-U02 Universal Driver Module	198
PT5B Series Pressure Transmitters	199
PM Series Pulse width Modulating (PWM) Expansion Valves	201
<b>PM Series extended capacity tables</b>	
PM Series extended capacity tables	213
<b>Electronic expansion valves capacity tables</b>	
Electronic expansion valves capacity tables	231

<b>Refrigerant solenoid valves</b>	
Refrigerant solenoid valves quick selection guide	250
100RB Series Refrigerant Solenoid Valves	251
200RB Series Refrigerant Solenoid Valves	253
200RC Series Refrigerant Solenoid Valves	257
250RA Series Refrigerant Solenoid Valves	259
500RB Series Refrigerant Solenoid Valves	262
540RA Series Refrigerant Solenoid Valves	264
Solenoid Multi-Purpose Tool	266
<b>Solenoid coils</b>	
Coils for solenoid valves	267
<b>Refrigerant solenoid capacity tables</b>	
Refrigerant solenoid capacity tables	269
<b>Industrial solenoid valves</b>	
Industrial solenoid valves	286
202CB Series Industrial Solenoid Valves	287
203CA Series Industrial Solenoid Valves	288
204CD Series Industrial Solenoid Valves	289
210CA / 211CA Series Industrial Solenoid Valves	290
214CB Series Industrial Solenoid Valves	292
222CB Series Industrial Solenoid Valves	293
<b>Filter driers</b>	
Filter drier quick selection guide	295
EK Series Hermetic Liquid Line Filter Driers	296
ADK Series Hermetic Liquid Line Filter Driers	300
BFK Series Hermetic Liquid Line Bi-Directional Filter Driers	303
Builder Series Hermetic Filter Driers	305
BOK Series Hermetic Liquid Line Filter Driers	306
CU Series Spun Copper Hermetic Liquid Line Filter Driers	308
ALF Series Hermetic Liquid Line Filters	309
STAS Series Take-Apart Liquid and Suction Filter Driers	310
ADKS Series Take-Apart Liquid & Suction Line Filters Driers	313
Filter Drier Cores and Filters for Take-Apart Shells	314
BTAS Series Take-Apart Suction Line Filter Driers	316
ASD Series Premium Hermetic Suction Line Filter Driers	318
SFD Series Hermetic Suction Line Filter Driers	319
CSFD Series Hermetic Compact Suction Line Filter Driers	320
ASK Series Hermetic Suction Line Filter Driers	321
ASF Series Hermetic Suction Line Filters	322
<b>Moisture indicators</b>	
HMI Series Hermetic Moisture Indicators	329
AMI Series Take-Apart Moisture Indicators	331
A-IHL Series Moisture Indicators	333

<b>Mufflers &amp; accumulators</b>	
APD Series Pulsation Dampener / Muffler	334
A-AS Series Suction Accumulators	335
<b>Shut off valves</b>	
BV Series Ball Valves	337
BVSS Series Ball Valves	338
ACK Series Check Valve	340
A-FC / A-WC High Efficiency Centrifugal Oil Separator	341
A-F / A-W / A-WZ Series Oil Separators	343
A-FL Ultra High Performance Coalescent Oil Separator	345
AOR Series Oil Reservoirs	346
AOF / AOFD Series High Efficiency Oil Filters / Driers	347
OMB / OMC Series Oil Management Control	348
W-OLC Series Mechanical Oil Level Control	350
Oil Management Control Adapters	351
DCFV Charge Calculations	353
<b>Refrigeration temperature controls</b>	
16E Digital Refrigeration Temperature Control	355
1600 Series Refrigeration Temperature Controls	356
200 Series Refrigeration Temperature Controls	357
<b>Pressure controls</b>	
PS1 Series Pressures Switch Single Control	358
PS2 Series Pressure Switch Dual Control	359
PSC Series Mini Pressure Control	360
FD113-ZUK Oil Pressure Safety	362
FSY Series Electric Fan Speed Control	363
A guide to the White-Rodgers numbering system	364
<b>General information</b>	
Electric & gas conversion & capacity tables	365
Full electrical ratings of White-Rodgers controls	366



1F76U-22WFB



1F76U-22WF



# Sensi Lite smart thermostat

Everything your customers are looking for in a smart thermostat - energy savings, modern design and lasting quality. Smart has never been so easy.

## Features

- Quick and simple installation. No common wire required with most systems.
- Familiar and intuitive controls.
- Your customers usage activity and personal data stays private.
- Aids in monitoring the effectiveness and efficiency of your customers' HVAC systems by providing valuable usage reports, equipment alerts, and maintenance reminders such as filter replacements.
- Top rated mobile app gives customers total on-the-go access to adjust their thermostat from anywhere, anytime.
- ENERGY STAR certified. Check for eligible utility rebates at [sensi.Copeland.com/rebates](http://sensi.Copeland.com/rebates)
- Saves about 23% of HVAC energy by adjusting the temperature using flexible scheduling, remote access and geofencing.
- Geofencing allows temperatures to change automatically based on the location of the homeowner's smartphone.
- Sensi easily integrates with popular smart home platforms including Amazon Alexa, Google Assistant and Samsung SmartThings.

## Specifications

Electrical rating hardwire.....20 to 30 VAC, 50/60 Hz  
 Electrical rating battery power..... N/A  
 Terminal load..... 1.5 Amps per terminal, 2.5 Amps maximum (all terminals combined)  
 Set-point range .....45 to 99°F (7 to 37°C)  
 Heat differential (conventional / gas / oil / elec).....Fast 0.5°F, Med. 0.75°, Slow 1.9°F  
 Cool differential (central air)..... Fast 0.9°F, Med. 1.2°, Slow 1.7°F  
 Heat pump differential (heat and cool)..... Fast 0.9°F, Med. 1.2°, Slow 1.7°F  
 Aux. heat differential.....Fast 0.5°F, Med. 0.75°, Slow 1.9°F  
 Operating humidity.....0%-90% RH non-condensing max.  
 Dimensions ..... 5.6 in. L X 3.25 in. H X .77 in. D  
 Storage temperature range..... -20 to 150°F (-29 to 65°C)

## Parts and accessories

Description	Model number	Item number
Wallplate (Black) 7" W X 4.6" H X 0.24" D	SA6B	SA6B
Wallplate (White) 7" W X 4.6" H X 0.24" D	SA6W	SA6W
Thermostat Guard - Clear Plastic	F29-0198	F29-0198

## Universal - 2 heat/1 cool or 1 heat/2 cool Sensi Lite Wi-Fsi thermostat

Programs	Stages by system	System type	Model number	Item number	Applications						Power source	Selectable performance features						Available connections					
					Gas / oil / electric	3 Wire zone valve	Milivolt compatible	Economizer	Humidity control	Dual fuel heat pump control logic (l) outdoor sensor (o)		Remote sensor options indoor (i) outdoor (o)	Battery (b) hardwire / Common (h) / power sharing (ps)	Auto changeover	Programmable fan (pf) comfort circulating fan (cc)	Filter change reminder	Energy mgt. Recovery / early start		Total keypad lockout (t) partial keypad lockout (p)	Set-point temperature limits Adjustable max / min	Display size, backlight with key press (k) continuous backlight with common (c)		
7, NP	8 Max	1/1	2/1 or 1/2	2/1	Universal Sensi Lite	1F76U-22WFB	1F76U-22WFB	√	√	—	—	—	L	—	H, PS	√	CC	√	√	T	√	2.3" LCD	R, C, W/E, G, Y, O/B*
7, NP	8 Max	1/1	2/1 or 1/2	2/1	Universal Sensi Lite	1F76U-22WF	1F76U-22WF	√	√	—	—	—	L	—	H, PS	√	CC	√	√	T	√	2.3" LCD	R, C, W/E, G, Y, O/B*

<sup>1</sup> Universal thermostats provide the flexibility to control single stage, multi-stage, or heat pump systems.



1F96U-42WF



1F96U-42WFB



**Sensi room sensors**

Sensi room sensors are designed to remotely monitor temperature and humidity in different rooms of your home. Sensors are sold separately.

# Sensi Touch 2 smart thermostat

Meet the next evolution of smart thermostats by Copeland. With a new modern design, glass LCD touchscreen, enhanced user experience and compatibility with room sensors, this thermostat proves why Sensi smart thermostats are top rated by consumers.

## Features

- **Works with room sensors:** Compatible with Sensi Room Sensors to balance temperatures throughout your customer’s home (sold separately).
- **Easy installation:** Step-by-step instructions and a traditional footprint makes install easy, no painting or patching needed.
- **Contractor branding:** Add your information on the thermostat sleep screen and in your customer’s app, to make sure you stay top of mind.
- **Accessory terminals:** Dedicated accessory terminals designed for humidifiers.
- **Smart maintenance:** Sensi can help monitor the performance and efficiency of your customer’s HVAC system by delivering valuable usage reports, alerts about their equipment, and maintenance reminders like filter replacement.
- **Smart home compatible:** Sensi easily integrates with popular smart home platforms including Amazon Alexa, Google Assistant and Samsung SmartThings.

## Specifications

Electrical rating hardwire..... 30 Vac, NEC Class II, 50/60 Hz  
 Electrical rating battery power..... N/A  
 Terminal load..... 1.5 Amps per terminal, 2.5 Amps maximum (all terminals combined)  
 Set-point range .....45 to 99°F (7 to 37°C)  
 Heat differential (conventional / gas / oil / elec) .....Fast 0.5°F, Med. 0.75°, Slow 1.9°F  
 Cool differential (central air) ..... Fast 0.9°F, Med. 1.2°, Slow 1.7°F  
 Heat pump differential (heat and cool) ..... Fast 0.9°F, Med. 1.2°, Slow 1.7°F  
 Aux. heat differential.....Fast 0.5°F, Med. 0.75°, Slow 1.9°F  
 Operating humidity.....0%-90% RH non-condensing max.  
 Dimensions ..... 5.6 in. L X 3.25 in. H X .77 in. D  
 Storage temperature range..... -40 to 150°F (-40 to 65°C)  
 Requires common wire ..... Yes

## Parts and accessories

Description	Model number	Item number
Room Sensor - 1 pack	RS01-SG	RS01-SG
Outdoor Sensor - 1 pack	OS01-SG	OS01-SG
Thermostat Guard - Clear Plastic	F29-0198	F29-0198
Wallplate (White) 6.75"W X 4.5"H	SA6W	SA6W
Wallplate (Black) 6.75"W X 4.5"H	SA6B	SA6B
Thermostat Common Wire Kit	SA11	SA11
Equipment Interface Module	SA20	SA20
EIM and Touch 2 Kit	SK20B	SK20B

## Universal – 4 heat / 2 cool Sensi Touch 2 smart thermostat

Programs		Stages by system			System type	Model number	Item number	Applications						Power source		Selectable performance features						Available connections		
7, NP, Geo	8 Max	1/1	2/2	4/2	Universal / Single Stage / Multi-Stage / Heat Pump 1			Gas / Oil / Electric	3 Wire Zone Valve	Milivolt Compatible	Economizer	Humidity Control	Dual Fuel Heat Pump Control Logic (L) Outdoor Sensor (O)	Remote Sensor Options Indoor (I) Outdoor (O)	Battery (B) Hardwire / Common (H) / Power Sharing (PS)	Auto Changeover	Programmable Fan (PF)	Comfort Circulating Fan (CC)	Filter Change Reminder	Energy Mgt. Recovery / Easy Start	Total Keypad Lockout (T)	Partial Keypad Lockout (P)	Set-Point Temperature Limits Adjustable Max / Min	Display Size, Backlight with Key Press (K) Continuous Backlight with Common (C)
7, NP, Geo	8 Max	1/1	2/2	4/2	Universal Sensi Touch 2	1F96U-42WF	1F96U-42WF	✓	✓	—	H, D	L, O	I, O	H	✓	CC	✓	✓	T	✓	4.3" Color	RC, RH, C, W/E, W2,Y, Y2, O/B, G, ACC+, ACC-		
7, NP, Geo	8 Max	1/1	2/2	4/2	Universal Sensi Touch 2	1F96U-42WFB	1F96U-42WFB	✓	✓	—	H, D	L, O	I, O	H	✓	CC	✓	✓	T	✓	4.3" Color	RC, RH, C, W/E, W2,Y, Y2, O/B, G, ACC+, ACC-		

<sup>1</sup> Universal thermostats provide the flexibility to control single stage, multi-stage, or heat pump systems.



1F95U-42WF



1F95U-42WFB



1F95U-42WFS

# Sensi Touch smart thermostat



Connect to comfort with Sensi Smart Thermostats - Anytime, Anywhere.

## Features

- HD color touchscreen display features easy to read temperatures and intuitive menus.
- Easy to install with easy-click terminals and built in level & easy to connect to Wi-Fi with step-by-step guide in the app.
- Contractor-On-Call feature stores your contact information so when your customer needs service, you're just a tap away. Sign up at [sensiregistration.com](http://sensiregistration.com)
- Provides multiple thermostat control for easy management for schools and light commercial applications.
- Smart alerts notify homeowners of extreme temperature and humidity levels.
- Controls humidification and dehumidification
- Circulating fan: Helps maximize comfort and balance temperature throughout your home by increasing air circulation.
- ENERGY STAR Certified and Title 24 compliant. Check for eligible utility rebates at [Sensi.Copeland.com/rebates](http://Sensi.Copeland.com/rebates)
- Saves about 23% of HVAC energy by adjusting the temperature using flexible scheduling, remote access and geofencing.
- Geofencing allows temperatures to change automatically based on the location of the homeowner's smartphone.
- Integrates directly with smart home platforms including Amazon Alexa, the Google Assistant, Apple HomeKit and Samsung SmartThings.

## Specifications

Electrical rating hardwire.....30 VAC, NEC Class II, 50/60 Hz  
 Electrical rating battery power.....N/A  
 Terminal load.....1.5 Amps per terminal, 2.5 Amps maximum (all terminals combined)  
 Set-point range .....45 to 99°F (7 to 37°C)  
 Heat differential (conventional / gas / oil / elec) .....Fast 0.5°F, Med. 0.75°, Slow 1.9°F  
 Cool differential (central air) .....Fast 0.9°F, Med. 1.2°, Slow 1.7°F  
 Heat pump differential (heat and cool) .....Fast 0.9°F, Med. 1.2°, Slow 1.7°F  
 Aux. heat differential.....Fast 0.5°F, Med. 0.75°, Slow 1.9°F  
 Operating humidity.....0%-90% RH non-condensing max.  
 Dimensions.....5.63"W X 3.38"H X 1.00"D  
 Storage temperature range.....-40 to 150°F (-40 to 65°C)

## Parts and accessories

Description	Model number	Item number
Thermostat Guard Clear Plastic	F29-0198	F29-0198
Wallplate (White) 6.75"W X 4.5"H	F61-2689	F61-2689
Wallplate (Black) 6.75"W X 4.5"H	SA5B	SA5B
Wallplate (Silver) 6.75"W X 4.5"H	SA5S	SA5S
Thermostat Common Wire Kit	SA11	SA11

## Universal - 4 heat / 2 cool Sensi Touch wi-fi thermostat

Programs	Stages by system			System type	Model Number	Item Number	Applications						Power source	Selectable performance features						Available connections		
	Periods Per Day Options	Single Stage Heat / Cool	Multi-Stage Heat / Cool				Heat Pump Heat / Cool	Univrs. / Single Stage / Multi-Stage / Heat Pump 1	Gas / Oil / Electric	3 Wire Zone Valve	Millivolt Compatible	Economizer		Humidity Control	Dual Fuel Heat Pump Control Logic (L) Outdoor Sensor (O)	Remote Sensor Options Indoor (I) Outdoor (O)	Battery (B) Hardwire / Common (H) Power Sharing (PS)	Auto Changeover	Programmable Fan (PF) Comfort Circulating Fan (CC)		Filter Change Reminder	Energy Mgt. Recovery / Early Start
7, NP, Geo	8 Max	1/1	2/2	4/2	Univrs. Sensi Touch	1F95U-42WF (White) 1F95U-42WFB (Black) 1F95U-42WFS (Silver)	√	√	—	—	H, D	L	—	H	√	CC	√	√	T	√	4.3" Color	RC, RH, C, W/E, W2/*, Y, Y2/*, O/B/6, G, L
7, NP, Geo	8 Max	1/1	2/2	4/2	Univrs. Sensi Touch	1F95U-42WFC (White) 1F95U-42WFBC (Black) 1F95U-42WFSC (Silver)	√	√	—	—	H, D	L	—	H	√	CC	√	√	T	√	4.3" Color	RC, RH, C, W/E, W2/*, Y, Y2/*, O/B/6, G, L

<sup>1</sup> Universal thermostats provide the flexibility to control single stage, multi-stage, or heat pump systems. \* Indicates Canadian Model Number: Call 1-800-305-6953 to order.



1F87U-42WF



# Sensi smart thermostat

Connect to comfort with Sensi Smart Thermostats - Anytime, Anywhere.

## Features

- Easy to install with built in level. No common wire (c-wire) required for most installations.
- Easy to connect to Wi-Fi with step-by-step guide in the Sensi app.
- Contractor-On-Call feature stores your contact information so when your customer needs service, you're just a tap away. Sign up at [sensiregistration.com](http://sensiregistration.com)
- Provides multiple thermostat control for easy management for schools and light commercial applications.
- Smart alerts notify homeowners of extreme temperature and humidity levels.
- Controls humidification and dehumidification
- Circulating fan: Helps maximize comfort and balance temperature throughout your home by increasing air circulation.
- ENERGY STAR Certified and Title 24 compliant. Check for eligible utility rebates at [Sensi.Copeland.com/rebates](http://Sensi.Copeland.com/rebates)
- Saves about 23% of HVAC energy by adjusting the temperature using flexible scheduling, remote access and geofencing.
- Geofencing allows temperatures to change automatically based on the location of the homeowner's smartphone.
- Integrates directly with smart home platforms including Amazon Alexa, the Google Assistant, Apple HomeKit and Samsung SmartThings.

## Parts and accessories

Description	Model number	Item number
Thermostat Guard Clear Plastic	F29-0198	F29-0198
Wallplate 6.75"W X 4.5"H	F61-2689	F61-2689
Thermostat Common Wire Kit	SA11	SA11

## Specifications

Electrical rating hardwire..... 20-30 VAC, NEC Class II, 50/60Hz  
 Electrical rating battery power..... 0 to 30 VAC, 50/60 Hz or DC  
 Terminal load..... 1.5 Amps per terminal, 2.5 Amps maximum (all terminals combined)  
 Set-point range ..... 45 to 99°F (7 to 37°C)  
 Heat differential (conventional / gas / oil / elec) .....Fast 0.5°F, Med. 0.75°, Slow 1.9°F  
 Cool differential (central air) ..... Fast 0.9°F, Med. 1.2°, Slow 1.7°F  
 Heat pump differential (heat and cool) ..... Fast 0.9°F, Med. 1.2°, Slow 1.7°F  
 Aux. heat differential.....Fast 0.5°F, Med. 0.75°, Slow 1.9°F  
 Operating humidity.....0%-90% RH non-condensing max.  
 Dimensions ..... 5.58"W X 3.75"H X 1.00"D  
 Storage temperature range..... -40 to 150°F (-29 to 65°C)

## Universal - 4 heat / 2 cool Sensi wi-fi thermostat

Programs	Stages by system	System type	Model number	Item number	Applications							Power source	Selectable performance features							Available connections		
					Gas / Oil / Electric	3 Wire Zone Valve	Millivolt Compatible	Economizer	Humidity Control	Dual Fuel Heat Pump Control Logic (L), Outdoor Sensor (O)	Remote Sensor Options Indoor (I), Outdoor (O)		Battery (B) Hardware / Common (H) Power Sharing (PS)	Auto Changeover	Programmable Fan (PF) Comfort Circulating Fan (CC)	Filter Change Reminder	Energy Mgt. Recovery / Early Start	Total Keypad Lockout (T) Partial Keypad Lockout (P)	Set-Point Temperature Limits Adjustable Max/Min		Display Size, Backlight with Key Press (K) Continuous Backlight with Common (C)	Terminals
7, NP, Geofencing	8 Max	1/1 / 2/2	4/2	Universal Sensi	1F87U-42WF	1F87U-42WF	√	√*	—	—	H, D	L	—	B, H, PS*	√	CC	√	√	T	√	5.0" K,C	RC, RH, C, W/E, W2*, Y, Y2*, O/B/2, G, L
7, NP, Geofencing	8 Max	1/1 / 2/2	4/2	Universal Sensi	1F87U-42WFC	1F87U-42WFC	√	√*	—	—	H, D	L	—	B, H, PS*	√	CC	√	√	T	√	5.0" K,C	RC, RH, C, W/E, W2*, Y, Y2*, O/B/2, G, L

<sup>1</sup> Universal thermostats provide the flexibility to control single stage, multi-stage, or heat pump systems.

\* Heat only, Cool only and 3-wire zone systems require common

✦ Indicates Canadian Model Number: Call 1-800-305-6953 to order.



**RS01-SG (1-Pack)**  
**RS01-SG3 (3-Pack)**

## Sensi room sensors

Sensi room sensors are designed to remotely monitor and control temperatures in different rooms of your home. When paired with the Sensi Touch 2 smart thermostat, room sensors can prioritize temperatures where you need it most while also helping to reduce hot and cold spots.

### Features

- Control the temperature where you need it most.
- Choose to average your temperature settings across all sensors and thermostat to help reduce hot and cold spots.
- View room temperatures and humidity levels across your home.
- No wires needed. Use the stand or mount directly on a wall.
- Sensi room sensors are only compatible with the Sensi Touch 2 smart thermostat.
- Connect and manage up to 15 Sensi room sensors with the Sensi Touch 2.

### Specifications

Product dimensions without stand..... 2.4 in. L X 2.4 in. H X .75 in. D  
 Product dimensions with stand ..... 2.4 in. L X 2.8 in. H X 1.2 in. D  
 Compatibility ..... Sensi Touch 2 Smart Thermostat  
 Max sensors per thermostat..... 15  
 Power source ..... 2 AAA Batteries  
 Battery life ..... Up to 2 Years  
 Warranty ..... 3 Years

### Accessory - Sensi room sensor

Compatibility	Remote sensor options, indoor (i), outdoor (o)	Dimensions	Weight	Color	Material	Model number	Item number	Mounting type	Hardware included	Range	Battery (b) hardware / common (h) power sharing (ps)	Batteries included	Power source	Battery life	Warranty
Sensi Touch 2 smart thermostat	i	2.4"W x 2.4"H x .75"D (sensor only) 2.4"W x 2.8"H x .75"D (with stand)	1.97 oz. (sensor only) 2.26 oz. (with stand)	White	Plastic	RS01-SG	RS01-SG	Wall / Stand	✓	Approx 100 ft.	B	✓	AAA Batt.	Up to 2 Years	3 Years



OS01-SG

# Sensi wireless outdoor sensor

Wireless outdoor sensor, compatible with Sensi Touch 2 smart thermostats to monitor the precise temperature and humidity level outside. Includes the sensor, (2) AA batteries, wall mount, and mounting hardware

## Features

- Use to control your balance point and auxiliary lockout at the thermostat for your heat pump system.
- View outdoor temperature from your Sensi app.
- Place anywhere on your property with a range of up to 100 ft.
- Lab tested to ensure functionality in all types of weather.

## Specifications

Product dimensions without stand .....3 in. W X 4.63 in. H X 1.5 in. D  
 Compatibility .....Sensi Touch 2 Smart Thermostat  
 Range ..... Up to 100 ft  
 Max sensors per thermostat ..... 1  
 Power source ..... 2 AA Batteries  
 Battery life ..... Up to 2 Years  
 Warranty ..... 3 Years

### Accessory - Sensi wireless outdoor sensor

Compatibility	Remote sensor options, indoor (i), outdoor (o)	Dimensions	Weight	Color	Material	Model number	Item number	Mounting type	Hardware included	Range	Battery (b) hardware common (h) power sharing (ps)	Batteries included	Power source	Battery life	Warranty
Sensi Touch 2 smart thermostat	o	3"W X 4.63"H X 1.5"D	5.6 oz.	White	Plastic	OS01-SG	OS01-SG	Wall	√	Up to 100 ft.	B	√	AA Batt.	Up to 2 Years	3 Years



**SA20 (1 pack)  
SK20B (EIM & Touch 2 Kit)**

# Sensi Equipment Interface Module (indoor + outdoor)

Sensi Equipment Interface Module streamlines HVAC wiring with one product that can solve many wiring challenges, eliminating the need to pull new wires when doing a system upgrade.

## Features

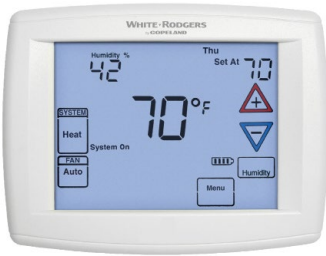
- Compatible with Sensi Touch 2 smart thermostat
- 3 optional accessory terminals for humidification, dehumidification and ventilation
- Wi-Fi included with Touch 2
- Waterproof and durable, this module can be used for indoor and outdoor applications
- Dedicated wire channels keep everything neatly organized. The cover is tightly secured on the product, keeping wires in place and hidden from view.
- Built-in temperature sensor

## Specifications

Product dimensions.....8.5" W X 6.75" H X 1.5" D  
 Usage ..... Indoor/outdoor  
 Power method.....Hardwired 24vac  
 Electrical rating..... 20 to 30 VAC, 50/60 Hz  
 ..... 1.5 Amps max per terminal  
 ..... 2.5 Amps max (all terminals combined)  
 Stages / max stages .....Conventional up to 3H/2C  
 .....Heat Pump up to 4H/2C  
 System type..... Universal  
 Terminals.....C, RC, RH, U1, U2, U3, W/D, W2, Y1, Y2, G, O/B, R, C  
 Program options.....Sensi Touch 2 smart thermostat; 7 day, NP

### Accessory - Sensi Equipment Interface Module

Compatibility	Remote sensor options, Indoor(I), Outdoor (O)	Dimensions	Weight	Color	Material	Model number	Order number	Mounting type	Hardware included	Range	Power source Battery (B) hardwire / common (H) Power sharing (PS)	Max EIM per thermostat	Power source	Smart Thermostat compatibility	Warranty
Sensi Touch 2 smart thermostat	I/O	8.5" W X 6.75" H X 1.5" D	5.6 oz.	White	Plastic	SA20	SA20	Wall	✓	Approx 100ft.	H	1	Hardwired 24vac	Yes	5 Years



1F95-1291

# Blue Series 12" touchscreen thermostats

Blue 12" Touchscreen - universal, commercial, humidity control and single stage thermostats provide ultimate comfort, features and performance.

## Features

- Universal models quickly configure for single stage, multi-stage or heat pump
- Heat pump dual fuel option (with or without outdoor sensor) eliminates the need for a fossil fuel kit
- Humidification/dehumidification control
- Commercial model offers occupied damper or economizer control
- Keypad lockout and set-point temperature limits
- Automatic changeover, Program fan and Indoor / Outdoor remote sensor options

## Parts and accessories

Description	Model number	Item number
Locking Thermostat Guard Clear Plastic	F29-0198	F29-0198
Locking Thermostat Guard Metal, Solid Base	F29-0220	F29-0220
Wallplate 8.13"W X 5.38"H	F61-2600	F0061 260000
Wallplate 6.50"W X 5.00"H	F61-2634	F0061 263400
Indoor Remote Sensor	F145-1328	F0145 132800S1
Outdoor Remote Sensor	F145-1378	F0145 137800S1

See Thermostat Guards for additional options.

## Specifications

Electrical rating hardwire..... 20 to 30 VAC, NEC Class II 50/60 Hz  
 Electrical rating battery power..... mV to 30 VAC, NEC Class II 50/60 Hz or DC  
 Terminal load..... 1.5 Amps per terminal, 2.5 Amps maximum (all terminals combined)  
 Set-point range ..... 45 to 99°F (7 to 37°C)  
 Heat differential (conventional / gas / oil / elec) ..... Fast 0.5°F, Slow 1.9°F  
 Cool differential (central air) ..... Fast 0.9°F, Slow 1.7°F  
 Heat pump differential (heat and cool) ..... Fast 0.9°F, Slow 1.7°F  
 Aux. heat differential ..... Fast 0.5°F, Slow 1.9°F  
 Operating humidity ..... 0%-90% RH non-condensing max.  
 Dimensions ..... 4.56"H X 5.81"W X 1.81"D  
 Storage temperature range ..... -40 to 150°F (-29 to 65°C)

## Universal staging/heat pump/single stage thermostats - Blue 12" thermostats

Programs	Stages by system			System type	Model number	Item number	Applications							Power source	Selectable performance features						Available connections	
	Periode Per Day Options	Single Stage Heat / Cool	Multi-Stage Heat / Cool				Heat Pump Heat / Cool	Gas / Oil / Electric	3 Wire Zone Valve	Milivolt Compatible	Economizer	Humidity Control	Dual Fuel Heat Pump Control Logic (L), Outdoor Sensor (O)		Remote Sensor Options Indoor (I) Outdoor (O)	Battery (B) Hardwire / Common (H) Power Sharing (PS)	Auto Changeover	Programmable Fan (PF) Comfort Circulating Fan (CC)	Filter Change Reminder	Energy Mgt. Recovery / Early Start		Total Keypad Lockout (T) Partial Keypad Lockout (P)
7, 5+1+1, NP	4, 2, 0	1/1	2/2	4/2	1F95-1291	1F95-1291	✓	✓	✓	—	H, D	L, O**	1 (I or O)	B, H, PS	✓	PF, CC	✓	✓	T, P	✓	12.0" K, C	RC, RH, C, W/E, W2, Y, Y2, O/B, G, L, 6, +, S, -, DHM, HM
7, 5+1+1, NP	2, 0	1/1	2/2	4/2	1F95-1280	1F95-1280	✓	✓	✓	✓	—	L, O**	1 (I or O)	B, H, PS	✓	PF, CC*	✓	✓	T, P	✓	12.0" K, C	RC, RH, C, W/E, W2, Y, Y2, O/B, G, L, 6, +, S, -, A1
7, 5+1+1, NP	4, 2, 0	1/1	2/2	3/2	1F95-1277	01F95 1277	✓	✓	✓	—	—	L, O**	1 (I or O)	B, H, PS	✓	PF, CC	✓	✓	T, P	✓	12.0" K, C	RC, RH, C, W/E, W2, Y, Y2, O/B, G, L, 6, +, S, -
7, 5+1+1, NP	4, 2, 0	1/1	—	2/1	1F97-1277	01F97 1277	✓	✓	✓	—	—	L, O**	1 (I or O)	B, H, PS	✓	PF, CC	✓	✓	T, P	✓	12.0" K, C	RC, RH, C, W/E, Y, O/B, G, L, 6, +, S, -

1 Universal thermostats provide the flexibility to control single stage, multi-stage, or heat pump systems. ◇ 4/2 on Dual Fuel systems when using an Outdoor Remote Sensor.  
 \* Occupancy fan option with selectable pre-purge (1-3 hours).  
 \*\* Outdoor sensor provides outdoor temperature settings to lock out auxiliary heat and/or lock out the heat pump and switch to gas heat.



1f95ez-0671

# Blue Series 6" thermostats

Blue 6" universal, commercial and Easy Reader thermostats offer more premium features than higher priced competitive models.

## Features

- Universal models quickly configure for single stage, multi-stage or heat pump
- Heat pump dual fuel option (with or without outdoor sensor) eliminates the need for a fossil fuel kit on selected models
- Easy Reader model is easy to read and easy to use
- Commercial offers occupied damper or economizer control and locking cover and subbase
- Keypad lockout and set-point temperature limits
- Automatic changeover, Program fan and Indoor / Outdoor remote sensor options available on selected models

## Parts and accessories

Description	Model number	Item number
Locking Thermostat Guard Clear Plastic	F29-0198	F29-0198
Locking Thermostat Guard Metal Solid Base	F29-0220	F29-0220
Wallplate 8.13"W X 5.38"H	F61-2600	F0061 260000
Wallplate 6.50"W X 5.00"H	F61-2634	F0061 263400
Indoor Remote Sensor	F145-1328	F0145 132800S1
Outdoor Remote Sensor	F145-1378	F0145 137800S1

See Thermostat Guards for additional options.

## Specifications

Electrical rating hardwire..... 20 to 30 VAC, NEC Class II 50/60 Hz  
 Electrical rating battery power..... mV to 30 VAC, NEC Class II 50/60 Hz or DC  
 Terminal load..... 1.5 Amps per terminal, 2.5 Amps maximum (all terminals combined)  
 Set-point range ..... 45 to 99°F (7 to 37°C)  
 Heat differential (conventional / gas / oil / elec) ..... Fast 0.5°F, Med. 0.75°, Slow 1.9°F  
 Cool differential (central air) ..... Fast 0.9°F, Med. 1.2°, Slow 1.7°F  
 Heat pump differential (heat and cool) ..... Fast 0.9°F, Med. 1.2°, Slow 1.7°F  
 Aux. heat differential..... Fast 0.5°F, Med. 0.75°, Slow 1.9°F  
 Operating humidity..... 0%-90% RH non-condensing max.  
 Dimensions ..... 4.19"H X 6.50"W X 1.63"D  
 Storage temperature range..... -40 to 150°F (-29 to 65°C)

## Universal staging/heat pump thermostats - Blue 6" thermostats

Programs	Stages by system	System type	Model number	Item number	Applications						Power source	Selectable Performance features						Available Connections			
					Gas / Oil / Electric	3 Wire Zone Valve	Millivolt Compatible	Economizer	Humidity Control	Dual Fuel Heat Pump Control Logic (L) Outdoor Sensor (O)		Remote Sensor Options Indoor (I) Outdoor (O)	Battery (B) Hardwire / Common (H) Power Sharing (PS)	Auto Changeover	Programmable Fan (PF) Comfort Circulating Fan (CC)	Filter Change Reminder	Energy Mgt. Recovery / Early Start		Total Keypad Lockout (T) Partial Keypad Lockout (P)	Set-Point Temperature Limits Adjustable Max/Min	Display Size, Backlight with Key Press (K) Continuous Backlight with Common (C)
7, 5+1+1, NP	4, 2, Ø	1/1 2/2 4/2	Universal Commercial	1F95-0680	1F95-0680	√	√	√	—	—	O**	1 (I or O)	B, H, PS	√	PF*	√	√	T, P	√	6.0" K,C	RC, RH, C, W/E, W2, Y, Y2, O/B, G, L, 6, +, S, -, A1
7, 5+1+1, NP	4, 2, Ø	1/1 2/2 4/2	Universal	1F95-0671	1F95-0671	√	√	√	—	—	O**	1 (I or O)	B, H, PS	√	PF	√	√	T, P	√	6.0" K,C	RC, RH, C, G, Y, Y2, W/E, W2, O/B, L, 6, +, S, -
7, NP	4, 2, Ø	1/1 2/2 4/2	Universal Easy Reader	1F95EZ-0671	1F95EZ-0671	√	√	√	—	—	L	—	B, H, PS	—	—	√	√	—	√	6.0" K,C	RC, RH, C, W/E, W2, Y, Y2, O/B, G, L, 6

1 Universal thermostats provide the flexibility to control single stage, multi-stage, or heat pump systems.  
 \* Occupancy fan option with selectable pre-purge (1-3 hours).  
 \*\* Outdoor sensor provides outdoor temperature settings to lock out auxiliary heat and/or lock out the heat pump and switch to gas heat.



1F82-0261

# Blue Series 2" thermostats

Heat pump or single stage models, offer a step up from 70 Series.

## Features

- Easy Set models feature simple Home-Sleep-Away preset buttons
- Programmable, 5/1/1 day, 24 hour, 0-day or non-programmable
- Lighted display for easier low light viewing
- Air filter change indicator option
- Cool Savings saves energy during peak A/C demand periods

## Specifications

Electrical rating hardwire..... 20 to 30 VAC, NEC Class II 50/60 Hz  
 Electrical rating battery power..... mV to 30 VAC, NEC Class II 50/60 Hz or DC  
 Terminal load..... 1.5 Amps per terminal, 2.5 Amps maximum (all terminals combined)  
 Set-point range ..... 45 to 99°F (7 to 37°C)  
 Heat differential (conventional / gas / oil / elec).....Fast 0.5°F, Med. 0.75°, Slow 1.9°F  
 Cool differential (central air)..... Fast 0.9°F, Med. 1.2°, Slow 1.7°F  
 Heat pump differential (heat and cool) ..... Fast 0.9°F, Med. 1.2°, Slow 1.7°F  
 Aux. heat differential.....Fast 0.5°F, Med. 0.75°, Slow 1.9°F  
 Operating humidity.....0%-90% RH non-condensing max.  
 Dimensions..... 3.75"H X 5.88"W X 1.00"D  
 Storage temperature range..... -40 to 150°F (-29 to 65°C)

## Parts and accessories

Description	Model number	Item number
Locking Thermostat Guard Clear Plastic	F29-0198	F29-0198
Locking Thermostat Guard Metal, Solid Base	F29-0220	F29-0220
Wallplate 6.50"W X 5.00"H	F61-2634	F0061 263400
Wallplate (6 pack of F61-2634 above)	F61-2648	F61-2648

See Thermostat Guards for additional options.

## Heat pump thermostats - Blue 2" thermostats

Programs	Stages by system			System type	Model number	Item number	Applications							Power source	Selectable performance features							Available connections	
	Periods Per Day Options	Single Stage Heat / Cool	Multi-Stage Heat / Cool				Heat Pump Heat / Cool	Universal / Single Stage / Multi-Stage Heat Pump <sup>1</sup>	Gas / Oil / Electric	3 Wire Zone Valve	Milivolt Compatible	Economizer	Humidity Control		Dual Fuel Heat Pump Control Logic (L) Outdoor Sensor (O)	Remote Sensor Options Indoor (I) Outdoor (O)	Battery (B) Hardwire / Common (H) Power Sharing (PS)	Auto Changeover	Programmable Fan (PF) Comfort Circulating Fan (CC)	Filter Change Reminder	Energy Mgt. Recovery / Early Start		Total Keypad Lockout (T) Partial Keypad Lockout (P)
5+1+1	4	—	—	2/1	Heat Pump	1F82-0261	1F82-0261	√	—	√	√	—	—	—	B, H	—	—	√	√	—	—	2.0" K,C	R, C, W2, Y, O/B, G, L
Easy Set Non-Programmable Home Sleep-Away	∅	—	—	2/1	Heat Pump	1F89EZ-0251	1F89EZ-0251	√	—	—	—	—	—	—	B, H	—	—	√	—	—	—	2.0" K,C	R, C, W2, Y, O/B, G, L
NP	∅	—	—	2/1	Heat Pump	1F89-0211	1F89-0211	√	—	√	—	—	—	—	B, H	—	—	√	—	—	—	2.0" K,C	R, C, W2, Y, O/B, G, L

## Single stage thermostats - Blue 2" thermostats

5+1+1	4	1/1	—	1/1	Single Stage	1F80-0261	1F80-0261	√	—	√	—	—	—	—	B, H	—	—	√	√	—	—	2.0" K,C	R, C, W, Y, O/B, G
24 Hours	4	1/1	—	1/1	Single Stage	1F80-0224	1F80-0224	√	—	√	—	—	—	—	B, H	—	—	√	√	—	—	2.0" K,C	R, C, W, Y, O/B, G
Easy Set Non-Programmable Home-Sleep-Away	3	1/1	—	1/1	Single Stage	1F86EZ-0251	1F86EZ-0251	√	—	√	—	—	—	—	B, H	—	—	√	—	—	—	2.0" K,C	R, C, W, Y, O/B, G
NP	∅	1/1	—	1/1	Single Stage	1F86-0244	1F86-0244	√	—	√	—	—	—	—	B, H	—	—	√	—	—	—	2.0" K,C	R, C, W, Y, O/B, G

<sup>1</sup> Universal thermostats provide the flexibility to control single stage, multi-stage, or heat pump systems.



1F85U-42PR

# 80 Series thermostats

Copeland 80 Series thermostats are the perfect fit for every application.

## Features

- Large display, bright backlight, high contrast screen
- Easy to install with built-in level, simple set-up menu and separate subbase
- Selectable programming, choice of 7 Day, 5+1+1 Day or Off is standard on all programmable models, auto changeover on all universal models
- Dual fuel control, no outdoor sensor required, standard on all staging models
- Keypad lockout and adjustable heat/cool temperature limits

## Parts and accessories

Description	Model number	Item number
Thermostat Guard Clear Plastic	F29-0198	F29-0198
Locking Thermostat Guard - Metal, Solid Base	F29-0220	F29-0220
Wallplate 6.75"W X 4.5"H	F61-2663	F61-2663

## Specifications

Electrical rating hardwire..... 20-30 VAC, NEC Class II 50/60Hz  
 Electrical rating battery power..... mV to 30 VAC  
 Terminal load..... 1.5 Amps per terminal, 2.5 Amps maximum (all terminals combined)  
 Set-point range ..... 45 to 99°F (7 to 37°C)  
 Heat differential (conventional / gas / oil / elec) .....Fast 0.5°F, Med. 0.75°, Slow 1.9°F  
 Cool differential (central air) ..... Fast 0.9°F, Med. 1.2°, Slow 1.7°F  
 Heat pump differential (heat and cool) ..... Fast 0.9°F, Med. 1.2°, Slow 1.7°F  
 Aux. heat differential.....Fast 0.5°F, Med. 0.75°, Slow 1.9°F  
 Operating humidity..... 0%-90% RH non-condensing max.  
 Dimensions..... 5.58"W X 3.75"H X 1.13"D  
 Storage temperature range..... -40 to 150°F (-29 to 65°C)

## Model number nomenclature - Example: 1F85U-42PR

Series	System type	Dash	Max stages heat/cool	Programmability/special features
1F85	U	—	42	PR
1F83 = Thermostat Series 1F85 = Thermostat Series	U = Universal Thermostat for Single Stage, Multi-Stage Or Heat Pump Systems H = Heat Pump Thermostat for Systems With Or Without Aux. Heat C = Conventional Thermostat (Gas / Oil / Electric) or Single Stage Heat Pump (No Aux.)	Character Separator	42 = 4 Heat / 2 Cool 22 = 2 Heat / 2 Cool 21 = 2 Heat / 1 Cool 11 = 1 Heat / 1 Cool	PR = Programmable NP = Non-Programmable WF = Wi-Fi Thermostat

## Universal staging / heat pump thermostats - 80 Series thermostats

Programs	Stages by system			System type	Model number	Item number	Applications							Power source	Selectable performance features							Available connections	
	Periods Per Day Options	Single Stage Heat / Cool	Multi-Stage Heat / Cool				Heat Pump Heat / Cool	Universal / Single Stage / Multi-Stage / Heat Pump 1	Gas / Oil / Electric	3 Wire Zone Valve	Millivolt Compatible	Economizer	Humidity Control		Dual Fuel Heat Pump Control Logic (L) Outdoor Sensor (O)	Remote Sensor Options Indoor (I)Outdoor (O)	Battery (B) Hardwire / Common (H) Power Sharing (PS)	Auto Changeover	Programmable Fan (PF) Comfort Circulating Fan (CC)	Filter Change Reminder	Energy Mgt. Recovery / Early Start		Total Keypad Lockout (T) Partial Keypad Lockout (P)
7, 5+1+1, NP	4, 2, Ø	1/1	2/2	4/2	Univrsl.	1F85U-42PR	1F85U-42PR	√	√	√	—	—	L	—	B, H	√	—	√	√	T	√	5.0" K,C	RC, RH, C, W/E, W2, Y, Y2, O/B/6, G, L
7, 5+1+1, NP	4, 2, Ø	1/1	2/2	2/1	Univrsl.	1F85U-22PR	1F85U-22PR	√	√	√	—	—	L	—	B, H	√	—	√	√	T	√	5.0" K,C	RC, RH, C, W/E, W2, Y, Y2, O/B/6, G, L
7, 5+1+1, NP	4, Ø	—	—	2/1	Heat Pump	1F83H-21PR	1F83H-21PR	√	—	—	—	—	L	—	B, H	—	—	√	√	T	√	4.5" K,C	R, C, W2, E, Y, O/B, G, L
NP	Ø	1/1	2/2	4/2	Univrsl.	1F85U-42NP	1F85U-42NP	√	√	√	—	—	L	—	B, H	√	—	—	—	T	√	5.0" K,C	RC, RH, C, W/E, W2, Y, Y2, O/B/6, G, L
NP	Ø	1/1	2/2	2/1	Univrsl.	1F85U-22NP	1F85U-22NP	√	√	√	—	—	L	—	B, H	√	—	—	—	T	√	5.0" K,C	RC, RH, C, W/E, W2, Y, Y2, O/B/6, G, L
NP	Ø	—	—	2/1	Heat Pump	1F83H-21NP	1F83H-21NP	√	—	—	—	—	L	—	B, H	—	—	—	—	T	√	4.5" K,C	R, C, W2, E, Y, O/B, G, L
7, 5+1+1, NP	4, Ø	1/1	—	1/1	Single Stage	1F83C-11PR	1F83C-11PR	√	—	√	—	—	—	—	B, H	—	—	√	√	T	√	4.5" K,C	RC, RH, C, W, Y, O/B, G
NP	Ø	1/1	—	1/1	Single Stage	1F83C-11NP	1F83C-11NP	√	—	√	—	—	—	—	B, H	—	—	—	—	T	√	4.5" K,C	RC, RH, C, W, Y, O/B, G

<sup>1</sup> Universal thermostats provide the flexibility to control single stage, multi-stage, or heat pump systems.



1F89-211



1F87-361

# Classic 80 Series thermostats

Our Classic 80 Series is available as universal, heat pump and single stage styles offering proven performance and reliability.

## Features

- Choice of battery powered, dual power or hardwired models
- Fossil fuel or electric heat compatible
- Permanent program retention during power loss
- Configuration menu allows keypad selection of options
- Selectable energy management recovery (1F80-361 / 1F87-361 / 1F82-261)

## Specifications

Electrical rating hardwire..... 20-30 VAC, NEC Class II 50/60Hz  
 Electrical rating battery power..... mV to 30 VAC  
 Terminal load..... 1.5 Amps per terminal, 2.5 Amps maximum (all terminals combined)  
 Set-point range ..... 45 to 99°F (7 to 37°C)  
 Heat differential (conventional / gas / oil / elec) ..... Fast 0.5°F, Slow 1.9°F  
 Cool differential (central air) ..... 1.2°F  
 Heat pump differential (heat and cool) ..... Fast 0.9°F, Slow 1.7°F  
 Aux. heat differential..... Fast 0.5°F, Slow 1.9°F  
 Operating humidity..... 0%-90% RH non-condensing max.  
 Dimensions ..... 3.88"H X 6.00"W X 1.88"D  
 Storage temperature range..... -40 to 150°F (-29 to 65°C)

## Parts and accessories

Description	Model number	Item number
Thermostat Guard - Clear Plastic	F29-0198	F29-0198
Locking Thermostat Guard - Metal, Solid Base	F29-0220	F29-0220
Wallplate for all Classic 1F80's 4.63"W X 7.63"H Includes adapter plate for mounting to horizontal or vertical junction box	F61-2500	F0061 250000S1

See Thermostat Guards for additional options.

## Universal staging / heat pump thermostats - Classic 80 Series thermostats

Program Options	Programs			Stages by system			System type	Model number	Item number	Applications								Power source	Selectable performance features								Available connections	
	Periods Per Day	Options	Heat / Cool	Single Stage	Multi-Stage	Heat / Cool				Gas / Oil / Electric	3 Wire Zone Valve	Millivolt Compatible	Economizer	Humidity Control	Dual Fuel Heat Pump Control Logic (L)	Outdoor Sensor (O)	Remote Sensor Options Indoor (I) Outdoor (O)		Battery (B)	Hardwire / Common (H)	Power Sharing (PS)	Auto Changeover	Programmable Fan (PF)	Comfort Circulating Fan (CC)	Filter Change Reminder	Energy Mgt. Recovery / Early Start		Total Keypad Lockout (T)
5+1+1	4	—	—	2/1	—	—	Heat Pump	1F82-261	01F82 261S1	√	—	—	—	—	—	H	—	—	—	√	√	—	—	—	—	1.8"	—	R, C, W2, E, Y, O/B, G, L
NP	0	—	—	2/1	—	—	Heat Pump	1F89-211	01F89 211S1	√	—	—	—	—	—	H	—	—	—	√	—	—	—	—	—	1.8"	—	R, C, W2, E, Y, O/B, G, L
7-day	4	1/1	—	1/1	—	—	Single Stage	1F87-361	01F87 361	√	—	√	—	—	—	B, H	—	—	—	√	√	—	—	—	—	2.2"	—	RC, RH, C, W, Y,O, B, G
5+1+1	4	1/1	—	1/1	—	—	Single Stage	1F80-361	01F80 361	√	—	√	—	—	—	B, H	—	—	—	√	√	—	—	—	—	2.2"	—	RC,RH, C, W, Y,O, B, G
NP	0	1/1	—	1/1	—	—	Single Stage	1F86-344	01F86 344	√	—	√	—	—	—	B, H	—	—	—	√	—	—	—	—	—	2.2"	—	RC, RH, C, W, Y,O, B, G

<sup>1</sup> Universal thermostats provide the flexibility to control single stage, multi-stage, or heat pump systems.



1F75C-11PR



1F75C-11NP

# 70 Series thermostats

The 70 Series provides an easy-to-use thermostat with a modern design that helps reduce complexity for the customer and in turn helps reduce contractor callbacks.

## Features

- Large display, bright backlight, high contrast screen
- Easy to install with built-in level, simple set-up menu and separate subbase
- Selectable programming, choice of 7 Day, 5+1+1 Day or Off is standard on all programmable models, auto-changeover on all universal models
- Dual-fuel control, no outdoor sensor required, standard on all staging models

## Specifications

Electrical rating hardwire (heat pump).....Hardwire: 20 to 30 VAC  
 Electrical rating battery power (single stage)  
 Terminal load..... 1.5 A per terminal  
 ..... 2.5 A per maximum all terminals combined  
 Set-point range .....45 to 99°F (7 to 37°C)  
 Heat differential (conventional/gas/oil/elec) .....Fast 0.5°F, Med. 0.75°, Slow 1.9°F  
 Cool differential (central air) ..... Fast 0.9°F, Med. 1.2°, Slow 1.7°F  
 Heat pump differential (heat and cool) ..... Fast 0.9°F, Med. 1.2°, Slow 1.7°F  
 Aux. heat differential.....Fast 0.5°F, Med. 0.75°, Slow 1.9°F  
 Operating humidity.....0%-90% RH non-condensing max.  
 Dimensions.....3-3/4"H x 6"W x 1-1/8"D  
 Storage temperature range.....-20°F to +150°F (-29°C to +65°C)

## Parts and accessories

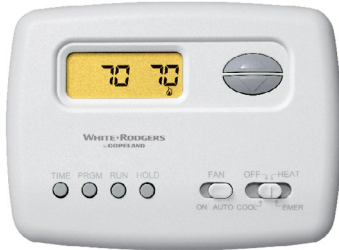
Description	Model number	Item number
Thermostat Guard	F29-0198	F29-0198
Wallplate (6-3/4" x 4-1/2")	F61-2663	F61-2663

### Heat pump thermostats - 70 series thermostats

Programs	Stages by system			System type	Model number	Item number	Applications							Power source	Selectable performance features						Available connections				
	Periods Per Day Options	Single Stage Heat / Cool	Multi-Stage Heat/ / Cool				Heat Pump Heat/ / Cool	Universal / Single Stage / Multi-Stage / Heat Pump 1	Gas / Oil / Electric	3 Wire Zone Valve	Millivolt Compatible	Economizer	Humidity Control		Dual Fuel Heat Pump Control Logic (L) Outdoor Sensor (O)	Remote Sensor Options Indoor (I)Outdoor (O)	Battery (B) Hardware / Common (H) Power Sharing (PS)	Auto Changeover	Programmable Fan (PF) Comfort Circulating Fan (CC)	Filter Change Reminder		Energy Mgt. Recovery / Early Start	Total Keypad Lockout (T) Partial Keypad Lockout (P)	Set-Point Temperature Limits Adjustable Max/Min	Display Size, Backlight with Key Press (K) Continuous Backlight with Common (C)
NP	—	—	—	2/1	Heat Pump	1F75H-21NP	1F75H-21NP	✓	—	—	—	—	L	—	B, H	—	—	—	—	—	—	—	✓	3" C	R, Y, G, E, W2, O/B, C
7, 5 + 1 + 1, NP	4	—	—	2/1	Heat Pump	1F75H-21PR	1F75H-21PR	✓	—	—	—	—	L	—	B, H	—	—	✓	✓	—	—	—	✓	3" C	R, Y, G, E, W2, O/B, C

### Single stage thermostats - 70 series thermostats

NP	—	1/1	—	1/1	Single Stage	1F75C-11NP	1F75C-11NP	✓	—	✓	—	—	—	—	B, H	—	—	—	—	—	—	—	✓	3" C	RC, RH, Y, W, O/B, G, C
7, 5 + 1 + 1, NP	4	1/1	—	1/1	Single Stage	1F75C-11PR	1F75C-11PR	✓	—	✓	—	—	—	—	B, H	—	—	✓	✓	—	—	—	✓	3" C	RC, RH, Y, W, O/B, G, C



1F72-151

# Classic 70 Series thermostats

The perfect upgrade from mechanical thermostats available in heat pump or single stage that offer economy and value with proven reliability.

## Features

- Horizontal and vertical models
- Programmable and non-programmable models
- Selectable Celsius or Fahrenheit temperature display
- Fossil fuel or electric heat compatible
- Electronic accuracy
- Temperature accuracy for customers on a budget

## Specifications

Electrical rating hardwire (heat pump)..... 20 to 30 VAC, NEC Class II 50/60 Hz  
 Electrical rating battery power (single stage) .....mV to 30 VAC, NEC Class II 50/60 Hz or DC  
 Terminal load..... 1.5 amps per terminal, 2.5 amps maximum (all terminals combined)  
 Set-point range ..... 45 to 99°F (7 to 37°C)  
 Heat differential (conventional / gas / oil / elec) ..... Fast 0.75°, Slow 1.9°F  
 Cool differential (central air)..... 1.2°F  
 Heat pump differential (heat and cool) ..... Fast 0.9°F, Slow 1.7°F  
 Aux. heat differential..... Fast 0.5°F, Slow 1.9°F  
 Operating humidity..... 0%-90% RH non-condensing max.  
 Dimensions ..... 3.19"H X 5.13"W X 1.13"D  
 Storage temperature range..... -40 to 150°F (-29 to 65°C)

## Parts & accessories

Description	Model number	Item number
Thermostat Guard - Clear Plastic	F29-0198	F29-0198
Locking Thermostat Guard - Metal, Solid Base	F29-0220	F29-0220
Wallplate for all Copeland 70 Series thermostats, 6.50"W x 4.50"H, Includes adapter plate for mounting to horizontal or vertical junction box	F61-2510	F0061 251000S1

See Thermostat Guards for additional options.

## 70 series thermostats

Programs	Stages by system	System type	Model number	Item number	Applications								Power source	Selectable performance features							Available connections				
					Gas /Oil/ Electric	3 Wire Zone Valve	Millivolt Compatible	Economizer	Humidity Control	Dual Fuel Heat Pump Control Logic (L) Outdoor Sensor (O)	Remote Sensor Options Indoor (I) Outdoor (O)	Battery (B) Hardwire / Common (H) Power Staging (PS)		Auto Changeover	Programmable Fan (PF) Comfort Circulating Fan (CC)	Filter Change Reminder	Energy Mgt. Recovery / Early Start	Total Keypad Lockout (T) Partial Keypad Lockout (P)	Set-Point Temperature Limits Adjustable Max/Min	Display Size, Backlight with Key Press (K) Continuous Backlight with Common (C)					
5+2	4	—	2/1	Heat Pump	1F72-151	01F72 151S1	√	—	—	—	—	—	—	H	—	—	—	√	—	—	—	—	—	1.2" K, C	R, C, W2, E, Y, O/B, G, L
NP	∅	—	2/1	Heat Pump	1F79-111	01F79 111S1	√	—	—	—	—	—	—	H	—	—	—	—	—	—	—	—	—	1.2" K, C	R, C, W2, E, Y, O/B, G, L
5+2	4	1/1	—	1/1	Single Stage	1F78-151	01F78 151S1	√	—	√	—	—	—	B	—	—	—	√	—	—	—	—	—	1.2" K	RC, RH, W, Y, O, B, G
5+2	4	1/1	—	1/1	Single Stage Vertical	1E78-151	01E78 151	√	—	√	—	—	—	B	—	—	—	√	—	—	—	—	—	1.2" K	RC, RH, W, Y, O, B, G
NP	∅	1/1	—	1/1	Single Stage	1F78-144	01F78 144S1	√	—	√	—	—	—	B	—	—	—	—	—	—	—	—	—	1.2" K	RC, RH, W, Y, O, B, G
NP	∅	1/1	—	1/1	Single Stage Vertical	1E78-144	01E78 144	√	—	√	—	—	—	B	—	—	—	—	—	—	—	—	—	1.2" K	RC, RH, W, Y, O, B, G
NP	∅	1/0	—	—	Single Stage	1E78-140	01E78 140	√	—	√	—	—	—	B	—	—	—	—	—	—	—	—	—	1.2" K	RH, W

<sup>1</sup> Universal thermostats provide the flexibility to control Single Stage, Multi-Stage, or Heat Pump Systems. \* Does not control fan on a call for heat.



1F56N-444

# Standard mechanical thermostats

Mercury free replacement for White-Rodgers and competitive models installed over the past 50 years.

## Features

- Mercury free snap-action contacts with dust cover
- Horizontal and vertical models
- Built in bimetal thermometer
- Same footprint since the introduction of the series saves time and aggravation, so wall marks are not a problem and no cover-up wallplate is necessary
- 24 volt, 750 mV and 3 - wire zone options

## Specifications

Electrical rating..... mV to 30 VAC, NEC Class II 50/60 Hz  
 Heating anticipator .....Adjustable from 0.15 to 1.2 Amps  
 Cool anticipator .....Fixed  
 Differential (heat) ..... 1°F  
 Differential (cool) ..... 1.5°F  
 Set-point range .....50 to 90°F (10 to 32°C)  
 1E (vertical) dimensions.....4.5"H X 2.75"W X 1.5"D  
 1F (horizontal) dimensions.....2.75"H X 4.5"W X 1.50"D

## Parts & accessories

Description	Model number	Item number
Thermostat guard - clear plastic	F29-0198	F29-0198
Locking thermostat guard - metal, solid base	F29-0220	F29-0220
Wallplate for low voltage thermostats, 5.63"W x 5.75"H, includes horizontal or vertical "J" box adapter. for models 1D51W-, 1D56W, 1E30W, 1E56W, 1F56W, 1F58W	F61-2301	F0061 230100S1
Thermostat locking kit for types 1E30N, 1E50N, 1E56N, 1F51N, 1F56N	F92-0563	F0092 056300S1

See Thermostat Guards for additional options.

## Standard mechanical thermostats

Stages Heat / Cool	Heat Pump Heat / Cool	Includes	Gas / Oil / Electric	(Mv) Millivolt Compatible	3-Wire Zone Valve	Orientation Vertical, Horizontal	Terminals	Model number	Item number
1/0	—	Heat Only Wallplate (no System Off or Fan Switch)	√*	√	—	V	R, W	1E30N-910	1E30N-910
1/0	—	Heat Only Wallplate (no System Off or Fan Switch) / Switched Subbase Heat-Off / Optional F92-0563 Temperature Locking / Limiting Kit	√*	√	—	V	RH, W	1E50N-301	1E50N-301
1/1 ①	Heat Pump No Aux.	Heat Only Wallplate (no System Off or Fan Switch) / Switched Subbase Heat-Off-Cool & Fan Auto-On / Cool Only or 3-wire Zone Wallplate (no System Off or Fan Switch)	√	√	√	V	RC, RH, W, Y, O, B, G, A	1E56N-444	1E56N-444
1/1 ①	Heat Pump No Aux.	Heat Only Wallplate (no System Off or Fan Switch) / Switched Subbase Heat-Off-Cool & Fan Auto-On / Cool Only or 3-wire Zone Wallplate (no System Off or Fan Switch)	√	√	√	H	RC, RH, W, Y, O, B, G, A	1F56N-444	1F56N-444
1/0	—	Heat Only Wallplate (no System Off or Fan Switch)	√*	√	—	V	R, W	1E30N-311	1E30N-311
1/0	—	Heat Only Wallplate (no System Off or Fan Switch) / Switched Subbase Heat-Off / Optional F92-0563 Temperature Locking / Limiting Kit	√*	√	—	V	R, W	1E50N-303	1E50N-303
1/1 ①	Heat Pump No Aux.	Heat Only Wallplate (no System Off or Fan Switch) / Switched Subbase Heat-Off-Cool & Fan Auto-On / Cool Only or 3-wire Zone Wallplate (no System Off or Fan Switch)	√	√	√	V	RC, RH, W, Y, O, B, G, A	1E56N-361	1E56N-361
1/1 ①	Heat Pump No Aux.	Heat Only Wallplate (no System Off or Fan Switch) / Switched Subbase Heat-Off-Cool & Fan Auto-On / Cool Only or 3-wire Zone Wallplate (no System Off or Fan Switch)	√	√	√	H	RC, RH, W, Y, O, B, G, A	1F56N-361	1F56N-361

① Includes optional "A" terminal connection for Electric Heat systems that require the thermostat to energize the Blower (G terminal) on a call for heat.

\* Does not control fan on a call for heat.

✦ Indicates a Canadian Model Number: call 1-800-305-6953 to order.



1C20-101

# Economy mechanical thermostats

Mercury free reliable performance in an attractive design.

## Features

- Rugged snap-action contacts
- Adjustable heat anticipator
- Built in bimetal thermometer
- Heat / cool model includes switching subbase
- Heat / cool model compatible with electric heat systems

## Specifications

Electrical rating..... mV to 30 VAC, 50/60 Hz or DC  
 Heating anticipator .....Adjustable from 0.15 to 1.2 Amps  
 Cooling anticipator .....Fixed  
 Differential (heat)..... 2°F (1.1°C)  
 Differential (cool)..... 4°F (2.2°)  
 Set-point range ..... 50 to 90°F (10 to 32°C)  
 Dimensions ..... 3.75"H X 2.88"W X 1.50"D  
 Dimensions, switching models ..... 3.75"H X 3.13"W X 1.63"D

## Parts & accessories

Description	Model number	Item number
Thermostat Guard - Clear Plastic	F29-0198	F29-0198
Locking Thermostat Guard - Metal, Solid Base	F29-0220	F29-0220
Wall Coverplate for 1C20/1C26-XXX, 5.13"H X 5.00"W	F61-2499	F0061 249900S1

See Thermostat Guards for additional options.

## Economy mechanical thermostats

Stages heat / cool	Heat pump heat / cool	System switch	Fan switch	Gas / oil / electric	(Mv) millivolt compatible	Orientation vertical / horizontal	Terminals	Model number	Item number
1/0①③	—	None	None	√*	√	Vertical	R, W	1C20-101	01C20 101S1
1/0	—	None	None	√*	√	Vertical	R, W	1C20-102	01C20 102S1
0/1	—	None	None	—	—	Vertical	R, Y	1C21-101	01C21 101S1
1/1②③	Heat Pump No Aux.	Heat-Off-Cool	Auto-On	√	√	Vertical	RC, RH, W, Y, O, B, G, A	1C26-101	01C26 101S1

\* Does not control fan on a call for heat

① Lowest temperature setting is "OFF" position

② Includes optional "A" terminal connection for Electric Heat systems that require the thermostat to energize the Blower (G terminal) on a call for heat

③ Includes F61-2499 wall mounting plate to cover marks left by previous thermostat



1E65-144

# 1E65 line voltage digital thermostats

Line voltage digital thermostats for baseboard and resistance heat.

## Features

- LCD with great contrast for enhanced visibility
- 100% silent operation with optional proportional control feature
- Precise electric heat temperature control
- Digital non-programmable
- Celsius or Fahrenheit

## Specifications

Electrical rating..... 120/240 VAC, 50/60 Hz  
 1E65-144 minimum load..... 2 A (resistive only), 500 W @ 240 VAC, 250 W @ 120 VAC  
 1E65-144 maximum load..... 16.7 A (resistive only), 4000 W @ 240 VAC, 2000 W @ 120 VAC  
 Differential..... 1.0°F  
 Set-point range ..... 45 to 90°F (7 to 32°C)  
 Display resolution..... 1°F (0.1°C)  
 Approval..... CSA

## Parts & accessories

Description	Model number	Item number
Thermostat Guard - Clear Plastic	F29-0198	F29-0198
Junction box offset adapter plate for universal mounting. Allows offset for 1E65-144 9/16" Left or Right.	F61-2642	F61-264200

See Thermostat Guards for additional options.

## 1E65 Line Voltage Digital Thermostats

Heat / cool	Programmable	Switch action	120 Vac resistive (non-inductive)	240 Vac resistive (non-inductive)	Typical applications	Model number	Item number
Heat	—	Open on Rise	2.0A to 16.7A (250 to 2000W)	2.0A to 16.7A (500 to 4000W)	Baseboard Electric Heat, Convectors, Fan-forced Heaters, Radiant Floor or Ceiling Heat	1E65-144	01E65 144

1E65-144 replaces Honeywell RLV310.



1A65-641

# Line voltage baseboard thermostats - hydraulic

Line voltage mechanical thermostats for baseboard and resistance heat.

## Features

- Precision hydraulic switch action
- 1A66 types are a double-pole disconnect model with "OFF" position which mechanically breaks both sides of line
- Thermostat mounts on 2" X 4" electrical box
- Classic white or beige color
- Mercury free design

## Specifications

Differential..... 1.0°F (.5°C)  
 Set-point range .....40 to 85°F (4 to 29°C)  
 Dimensions for 1A65/1A66..... 4.5"H X 2.75"W X 1.25"D  
 Agency ..... UL

## Parts & accessories

Description	Model number	Item number
1A65-641, 1A65W-641, 1A66-641 or 1A66W-641 locking or limiting kit. Locks at 66°C 69°C 72°F or 75°F. Temperature limit can also be set at 60° or 63°.	F75-0176	F0075 017600S1

See Thermostat Guards for additional options.

## Line Voltage Baseboard Thermostats - Hydraulic

Heat / cool	Switch action	120 VAC Resistive (non-inductive)	240 VAC Resistive (non-inductive)	277 VAC Resistive (non-inductive)	Typical application	Model number	Item number
Heat	Open on rise	22.0A (2500W)	22.0A (5000W)	18.0A (5000W)	Baseboard Electric Heat, Cable Heat, Glass Panels	1A65-641	01A65 641S1
Heat	Open on rise	22.0A (2500W)	22.0A (5000W)	18.0A (5000W)	Baseboard Electric Heat, Cable Heat, Glass Panels	1A65W-641 ①	01A65W641S1
Heat	Open on rise	—	22.0A (5000W)	18.0A (5000W)	Baseboard Electric Heat, Cable Heat, Glass Panels	1A66-641	01A66 641S1
Heat	Open on rise	—	22.0A (5000W)	18.0A (5000W)	Baseboard Electric Heat, Cable Heat, Glass Panels	1A66W-641 ①	01A66W641S1

① W in model number denotes Classic White Color. Replaces Honeywell T498A / B SERIES.



**1G65-641**

# Line voltage baseboard thermostats - bimetal

Line voltage mechanical thermostats baseboard and resistance heat.

## Features

- Rugged bimetal switch action
- 1G66 types are a double-pole disconnect model with "OFF" position which mechanically breaks both sides of line
- Thermostat mounts on 2" X 4" electrical box
- Classic white
- Mercury free design

## Specifications

Differential..... 3.0°F (1.5°C)  
 Set-point range ..... 40 to 80°F (4 to 26°C)  
 Dimensions ..... 4.81"H X 3.31"W X 1.44"D  
 Agency .....UL, CSA

## Parts and accessories

Description	Model number	Item number
Thermostat guard - clear plastic	F29-0198	F29-0198

See Thermostat Guards for additional options.

## Line Voltage Baseboard Thermostats - Bimetal

Heat / cool	Switch action	120 Vac resistive (non-inductive)	240 Vac resistive (non-inductive)	277 Vac resistive (non-inductive)	Typical application	Model number	Item number
Heat	Open on rise	22.0A (2500W)	22.0A (5000W)	18.0A (5000W)	Baseboard Electric Heat, Cable Heat, Glass Panels	1G65-633	1G65-633
Heat	Open on rise	22.0A (2500W)	22.0A (5000W)	18.0A (5000W)	Baseboard Electric Heat, Cable Heat, Glass Panels	1G65-641	01G65 641
Heat	Open on rise	—	22.0A (5000W)	18.0A (5000W)	Baseboard Electric Heat, Cable Heat, Glass Panels	1G66-633	1G66-633
Heat	Open on rise	—	22.0A (5000W)	18.0A (5000W)	Baseboard Electric Heat, Cable Heat, Glass Panels	1G66-641	01G66 641

✦ Indicates Canadian Model Number: Call 1-800-305-6953 to order.



1A10-651

# Light & heavy duty line voltage thermostats

Line voltage mechanical thermostats light duty, heavy duty and fan coils.

## Features

- Two dial stops for setting a maximum or minimum temperature. Minimum between 66 to 87°F. Maximum between 60 to 81°F
- Includes set point locking feature at 66°, 69°, 72°, 75°, 78°, or 81°F
- Thermostat mounts on 2" X 4" electrical box
- Optional heating and cooling subbase S29-21 available
- Beige color / mercury free design

## Specifications

Differential..... 1.0°F  
 Set-point range ..... 36 to 90°F (2 to 32°C)  
 Dimensions without subbase ..... 4.5"H X 2.88"W X 1.75"D  
 Dimensions with subbase..... 5.13"H X 2.88"W X 2.75"D  
 Agency ..... UL

## Parts and accessories

Description	Model number	Item number
Thermostat Guard - Clear Plastic	F29-0198	F29-0198
Subbases for Use with 1A10-651 or 1A16-51 Line Voltage Thermostats, System Switch: Cool-Off-Heat	S29-21	S29 021S1

See Thermostat Guards for additional options.

## Light & heavy duty line voltage thermostats

Heat / cool	Switch action	120 Vac inductive (motor) full load	120 Vac inductive (motor) locked rotor	120 Vac resistive (non-inductive)	240 Vac inductive (motor) full load	240 Vac inductive (motor) locked rotor	240 Vac resistive (non-inductive)	277 Vac inductive (motor) full load	277 Vac inductive (motor) locked rotor	277 Vac resistive (non-inductive)	Pilot duty	Typical application	Model number	Item number
Heat / cool	SPDT	8.0A	48.0A	8.0A	4.0A	24.0A	8.0A	4.0A	24.0A	8.0A	125 VA	Fan Coils, Fans, Motor Starters, Circulators, Heating Valves, Cooling Valves, SPDT Applications, Baseboard Electric Heat, Radiant Floor or Ceiling Heat	1A10-651*	01A10 651S1
Heat / cool	SPDT	16.0A	96.0A	16.0A	8.0A	48.0A	16.0A	8.0A	48.0A	16.0A	125 VA	Fan Coils, Fans, Motor Starters, Circulators, Heating Valves, Cooling Valves, SPDT Applications, Baseboard Electric Heat, Radiant Floor or Ceiling Heat	1A16-51*	01A16 051S1

Optional heating and cooling subbase S29-21 available separately.

\* See White-Rodgers General Information for full electrical ratings.



1A11-2

## 1A11-2 fan coil thermostat

Fan coil units, valves, blower motors and 3 speed fan systems.

### Features

- 3-speed manual fan switch: High - Medium - Low
- System switch: Heat - OFF - Cool. "OFF" breaks both valve and fan circuits
- Mounts to a standard 2" X 4" vertical box or a two-gang outlet box. May also be mounted on a 4" X 4" junction box with an adapter (not provided)
- Color coded wiring for ease of installation
- Beige color

### Specifications

Differential..... 1.5°F  
 Set-point range .....36 to 90°F (2 to 32°C)  
 Dimensions ..... 4.50"H X 4.50"W X 2.25"D  
 Agency ..... UL

### Parts and accessories

Description	Model number	Item number
Thermostat Guard - Clear Plastic	F29-0198	F29-0198

See Thermostat Guards for additional options.

### 1A11-2 Fan Coil thermostat

Heat / Cool	Switch Action	120 VAC Inductive (Motor) Full Load	120 VAC Inductive (Motor) Locked Rotor	120 VAC Resistive (Non-Inductive)	240 VAC Inductive (Motor) Full Load	240 VAC Inductive (Motor) Locked Rotor	240 VAC Resistive (Non-Inductive)	277 VAC Inductive (Motor) Full Load	277 VAC Inductive (Motor) Locked Rotor	277 VAC Resistive (Non-Inductive)	Pilot Duty	Typical Application	Model number	Item number
Heat / Cool	SPDT Open / Close on Rise	5.5A	33.0A	—	2.75A	16.5A	—	2.3A	13.8A	—	120 VA	Fan Coil Units, Valves, Blower Motors, 3 Speed Fan Systems	1A11-2	01A11 002S1



152-10

## Line voltage steel case thermostats for heating & cooling

Line voltage mechanical thermostats with heavy gauge steel case.

### Features

- Models to control resistive heat loads or most heating / cooling inductive loads without a relay or motor starter
- "Summer" dial position (152-9 model)
- Hydraulic switch action unaffected by motion, no leveling required
- Open on rise and single pole double throw (SPDT) options
- Heavy gauge steel dustproof case, mounts on vertical 2" X 4" box or flush to wall

### Specifications

Dimensions ..... 6.00"H X 2.75"W X 2.50"D  
 Finish ..... Grey Color  
 Agency ..... UL, CSA

### Line voltage Steel Case Thermostats for heating & cooling

Switch action	Range	Differential	Motor rating (full load)		Resistive rating (non-inductive)			Model number	Item number
			120 Vac	240 Vac	120 Vac	240 Vac	277 Vac		
Open on Rise (Heating)	55 to 85°F (13 to 29°C)	Fixed 2°F (1.0°C)	14.0A	7.0A	25.0A	22.0A	18.0A	152-9*	01 52 009S1
Open on Rise (Heating)	40 to 90°F (4 to 32°C)	Fixed 3°F (1.6°C)	14.0A	7.0A	25.0A	20.0A	—	152-10**	01 52 010S1
SPDT (Heat / Cool)	55 to 95°F (13 to 35°C)	Fixed 3.0°F (1.6°C)	7.4A	3.7	—	—	—	179-1	01 79 001S1

\* Summer fan position control only has two terminals. It thermostatically cycles (based on temperature) unless set to the summer fan position in which case the contacts are closed.

\*\* Locked case, concealed dial.

See White-Rodgers General Information for full electrical ratings.



F145-1328

## Remote sensors for 24V Thermostats

Wired and wireless remote sensors for 24V thermostats. Indoor and outdoor sensors for Blue Series 12" and 6" digital thermostats, wireless indoor - outdoor sensor.

### Features

- Wired sensors provide superior temperature control, even over long wire runs
- Perfect for securing the thermostat in one area or room while sensing temperature in the conditioned space
- No temperature variance caused by wire resistance

### Specifications

Operating humidity.....0%-90% RH non-condensing max  
 Maximum distance from thermostat.....300'  
 Recommended wire (F145-1328 / F145-1378).....20 gauge, 3-conductor cable  
 F145-1328 / F145-1378 dimensions.....2.13"H X 3.5"W X .75"D

### Parts & accessories

Application	Remote sensor	Color	Model number	Item number
Compatible with all Copeland / White-Rodgers Thermostats that accept wired indoor remote sensors	Wired Indoor	Classic White	F145-1328	F0145 132800S1
Compatible with all Copeland / White-Rodgers Thermostats that accept wired outdoor remote sensors. Outdoor remote sensor has 12 ft. sensor lead.	Wired Outdoor	Classic White	F145-1378	F0145 137800S1

### Connection cross reference - Thermostats & wired sensors

Old terminal (thermostat or remote)	New terminal (thermostat or remote)
S1	+
S2	S
S3	-

### Wired remote sensor terminal designations

Model number	Terminal designation cross reference		
F145-1328 , F145-1378	+	S	-
	Sensor Positive	Sensor Return Signal	Sensor Negative



F29-0143

# Thermostat guards - plastic

Durable plastic thermostat guards are designed for use in public areas of offices, churches and restaurants to prevent tampering

## Features

- Each model furnished with one key and can be mounted vertically or horizontally
- Clear plastic models for applications that need the thermostat visible
- Each model furnished with a ring and/or solid wall mounting plate
- F29-0198 fits all Copeland/White-Rodgers thermostats

## Parts & accessories

Description	Model number	Item number
Key for Thermostat Guards (All)	F145-0999	F145-0999

## Thermostat guards selection

Model number		F29-0143		F29-0198		F29-0225	F29-0227		F29-0231	
Item number		F29-0143		F29-0198		F29-0225	F29-0227		F29-0231	
Base style		Ring	Solid	Ring	Solid	Ring	Ring	Solid	Ring	Solid
Digital	Sensi / Sensi Touch Wi-Fi	—	—	√	√	—	—	—	√	√
	70 Series	—	—	—	—	—	—	—	—	—
	Classic 70 Series	—	—	√	√	—	√	√	√	√
	80 Series	—	—	√	√	—	—	—	√	√
	Classic 80 Series	—	—	√	√	—	—	√	√	√
	Copeland Blue 2", 4"	√	√	√	√	—	√	√	√	√
	Copeland Blue 6", 12"	—	—	√	√	—	√	√	—	—
Mechanical	1C20 Series	√	√	√	√	√	√	√	√	√
	1E30 / 31 / 35 / 56 Series	√	√	√	√	—	√	√	√	√
	1F51 / 56 / 57 Series	√	√	√	√	—	√	√	√	√
Line Voltage	1A65 - 1A66 Series	—	—	√	—	—	√	—	√	—
	1G65 - 1G66 Series	—	—	√	—	—	√	—	√	—
	1A10 - 1A16 Series	—	—	√	—	—	—	—	—	—
	1A11 Series	—	—	√	—	—	—	—	—	—
	1E65 Series	—	—	√	—	—	√	—	—	—

## Thermostat guards dimensions

Description	(Ring) length	(Ring) height	(Ring) depth	(Solid) length	(Solid) height	(Solid) depth	Beko number	Model number	Item number
Clear plastic	6-1/4"	3-3/8"	3-1/4"	6-3/8"	3-1/2"	3"	BTG-RK	F29-0143	F29-0143
Clear plastic	8-1/8"	4-5/8"	3-5/8"	8-1/4"	5-3/8"	3-1/2"	BTG-UK2	F29-0198	F29-0198
Clear plastic	Mounting Plate, No Ring	Mounting Plate, No Ring	Mounting Plate, No Ring	3-7/8"	3-1/2"	2-1/2"	BTG-EK	F29-0225	F29-0225
Clear plastic	5-1/4"	4-5/8"	3-1/4"	5-1/4"	4-5/8"	3"	BTG-K	F29-0227	F29-0227
Clear plastic	7-1/16"	4-1/8"	2-1/4"	7-5/8"	4-1/4"	2-1/8"	TG-DK	F29-0231	F29-0231

All dimensions are horizontal inside dimensions.

**F29-0192**

## Thermostat guards - metal

Durable metal thermostat guards are designed for use in public areas of offices, churches and restaurants to prevent tampering

### Features

- Each model furnished with one key and can be mounted vertically or horizontally
- Beige enamel finish over heavy-duty steel enclosure with tamper-resistant design 18 gauge cover, 22 gauge frame
- Each model furnished with a ring and/or solid wall mounting plate
- F29-0220 fits all Copeland/White-Rodgers thermostats

### Parts & accessories

Description	Model number	Item number
Key for Thermostat Guards (All)	F145-0999	F145-0999


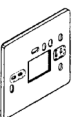

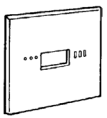
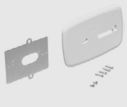


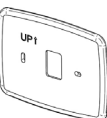




### Thermostat guards selection



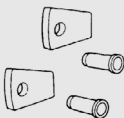
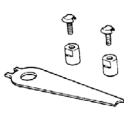
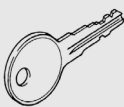

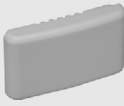



		Hinged cover	Hinged cover	No hinge	No hinge
Model number		F29-0192	F29-0193	F29-0220	F29-0222
Item number		F29-0192	F29-0193	F29-0220	F29-0222
Base style		Solid	Ring	Solid	Ring
Digital	Sensi / Sensi Touch Wi-Fi	—	—	—	—
	70 Series	—	—	—	—
	Classic 70 Series	√	√	√	√
	80 Series	—	√	√	√
	Classic 80 Series	—	√	√	√
	Copeland Blue 2", 4"	√	√	√	√
	Copeland Blue 6", 12"	—	—	√	√
Mechanical	1C20 Series	√	√	√	√
	1E30 / 31 / 35 / 56 Series	√	√	√	√
	1F51 / 56 / 57 Series	√	√	√	√
Line Voltage	1A65 - 1A66 Series	—	√	—	√
	1G65 - 1G66 Series	—	√	—	√
	1A10 - 1A16 Series	—	√	—	√
	1A11 Series	—	—	—	√
	1E65 Series	—	—	—	√

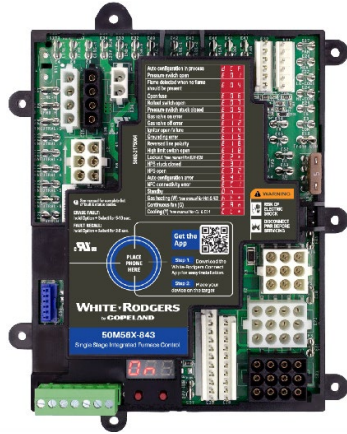
### Thermostat guards dimensions

Description	(Ring) length	(Ring) height	(Ring) depth	Comments	Beko number	Model number	Item number
Solid base	6-1/4"	4-3/4"	3"	Hinged cover	BTG-54VL	F29-0192	F29-0192
Ring base	6"	3-13/16"	3-1/8"	Hinged cover	BTG-54VLW	F29-0193	F29-0193
Solid base	7-1/8"	4-5/8"	3-1/4"	—	BTG-UM	F29-0220	F29-0220
Ring base	6-5/8"	4-1/2"	3-3/8"	—	BTG-UWM	F29-0222	F29-0222

All dimensions are horizontal inside dimensions.

	Description	Model number	Item number
	Wallplate for low voltage standard thermostats (55/8" h x 5-3/4" w). Beige. Includes adapter for mounting to vertical junction box. Same as f61-2068 except white.	F61-2301	F0061 230100S1
	Wallplate for all 1f90 series thermostats (except Copeland Blue 6" and 12" models), (7-1/4"W x 5-1/2"h), classic white color, includes adapter plate for mounting to horizontal or vertical junction box.	F61-2300	F0061 230000S1
	Wallplate for 1c20-xxx/1c26-xxx (5-5/8" h x 5" w)	F61-2499	F0061 249900S1
	Wallplate for all classic 80 series thermostats (except Copeland 2" and 4" and 80 series models), (7-5/8" w x 4-7/8" h), classic white color, includes adapter plate for mounting to horizontal or vertical junction box.	F61-2500	F0061 250000S1
	Wallplate for all 1f70 series thermostats, 6 1/2" w x 4 1/2" h, classic white color, includes adapter plate for mounting to horizontal or vertical junction box.	F61-2510	F0061 251000S1
	Wallplate for all 1f70 series thermostats, 6-1/2" w x 4-1/2" h, classic white color, does not include adapter plate for mounting to horizontal or vertical junction box.	F61-2550	F0061 255000S1
	Wallplate for Copeland blue 12", 6" thermostats, 8-1/8" w x 5-3/8" h, classic white color, for use with or without horizontal junction box.	F61-2600	F0061 260000
	Wallplate for Copeland blue 2", 4", 6", 12" thermostats, 6-1/2" w x 5" h, classic white color, for use with or without horizontal junction box.	F61-2634	F0061 263400
	Junction box offset adapter plate. Allows offset for 1e65-144 9/16" left or right.	F61-2642	F61-264200
	Same as f61-2634 except 6 Pack.	F61-2648	F61-264800
	Wallplate for Sensi smart thermostat and Copeland 80 Series 1F85U-42PR, -42NP, -22PR, -22NP, 1F83H-21PR, -21NP, 1F83C-11PR, -11NP, 6-3/4"W x 4-1/2"H for use with or without horizontal junction box.	F61-2663	F61-2663
	Wallplates for Sensi Touch smart thermostat. 6-3/4"W x 4-1/2"H	F61-2689 (white) SA5B (black) SA5S (silver)	F61-2689 (white) SA5B (black) SA5S (silver)

	Description	Model number	Item number
	Wallplates for Sensi Touch 2 and Sensi Lite smart thermostats. 7"W x 4.6"H	SA6W (white) SA6B (black)	SA6W (white) SA6B (black)
	Sensi room sensor - 1 pack	RS01-SG	RS01-SG
	Temperature knob locking or limiting kit for 1A65-641, 1A65W-641, 1A66-641 and 1A66W-641.	F75-0176	F0075 017600S1
	Temperature lever locking or temperature limiting kit for low voltage thermostats except 1C70, 1C20 and 1E26 series.	F92-0563	F0092 056300S1
	Replacement key for all thermostat guards, F29 series.	F145-0999	F145-0999
	Replacement door 1F90/1F97 (-51, -60, -71) 1F91-71, 1F92-71, 1F94-71, 1F95-71.	F145-1082	F0145 108200S1
	90 Series wired indoor remote sensor. Replaces all previous indoor remote sensors.	F145-1328	F0145 132800S1
	90 Series wired outdoor temperature sensor, for models with outdoor sensor option.	F145-1378	F0145 137800S1
	Wireless remote sensor for 1F98EZ-1621.	F145RF-1600	F145RF-1600
	Thermostat common wire kit	SA11	SA11



50M56X-843

# Universal Integrated Furnace Controls

Replaces over 700 OEM, White-Rodgers and competitive model numbers.

## Features

- Reduces inventory by providing maximum control replacement coverage
- Select models include a universal 120V nitride ignitor to allow replacement of 80V and 120V controls
- Diagnostic LED indicators streamline installation and system troubleshooting
- 120V air cleaner output and 120V humidifier output up to 1 Amp max
- Factory standard safety timings and adjustable fan delay options
- Replaceable automotive style fuse

## Specifications

Low voltage circuit.....	24 VAC, 50/60 Hz
Line voltage circuit.....	120 VAC, 50/60 Hz
Circulator relay.....	14.5 FLA - 25.0 LRA @ 120 VAC
Circulator relay: PSC.....	14.5 FLA - 25.0 LRA @ 120 VAC
Circulator relay: ECMx.....	12.0 mA @ 30 VAC
Operating temperature range.....	-40° to 175°F (-40° to 79°C)
Humidity range.....	5% to 93% relative humidity (non-condensing)

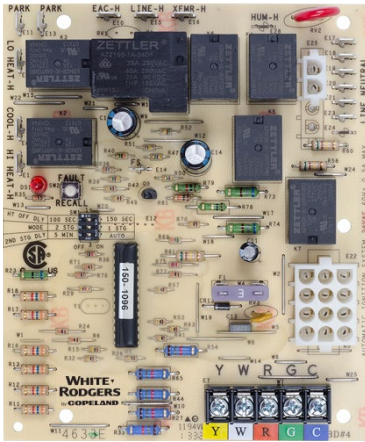
## Universal Integrated Furnace Controls

Family brands of equipment	Stages	Ignition type	Ignitor voltage	Inducer motor / blower motor	Blower motor speed taps	Thermostat inputs	Includes ignitor or electrode	Twining	Includes wiring accessories	Comm system	Control mounting	Model number	Item number
Carrier, Goodman, Lennox, Nordyne, Rheem, Trane, York	Single Stage	HSI	120 Vac*	PSC / PSC, ECMx	PSC - 2 or 3 speeds ECMx: 2, 3, 4, 5, & 9 speeds	R, C, W, G, Y1, Y/Y2, DHUM	√	√	—	—	Flush Mount	50M56X-843 <sup>1</sup>	50M56X-843
Carrier, Goodman, Lennox, Trane, York	Single Stage	HSI	120 Vac	PSC / PSC	Heat, Cool	R, C, W, Y G	—	√	√	—	Flush Mount	50A55-843	50A55-843S1
Goodman, Lennox, Trane	Single Stage	HSI	80 Vac only	PSC / PSC	Heat, Cool	R, C, W, Y G	—	—	—	—	Flush Mount	50A65-843	50A65-843S1
Goodman, Lennox, Trane, York	Two-Stage	HSI	120 Vac*	PSC / PSC	Lo Heat, Hi Heat, Cool	R, C, W1, W2, YLo, Y, G	√	√	—	—	Standoff	21M51U-843	21M51U-843
Goodman, Lennox, Trane, York	Two-Stage	HSI	120 Vac*	PSC / Var. Speed	16-pin Interface	R, B/C, W1, W2, YLo, Y, G, O, DHUM	√	—	√	—	Standoff	21V51U-843	21V51U-843

\* On 80 VAC applications use supplied 21D64-2 Universal Ignitor.

\*\* On 80 VAC applications purchase 21D64-2 Universal Ignitor.

1 NOTE: Coming Fall 2022, replaces 50M56U-843 & 50X57-843, uses White-Rodgers Connect app for quick configuration and diagnostics.



**50M56-743**

# Direct OEM Replacement Integrated Furnace Controls

Direct drop-in replacements for Carrier, Goodman, Lennox, Trane and York.

## Features

- Direct OEM replacements designed for high-volume major brand controls
- Models include PSC, Var. speed and ECMx motor control
- Diagnostic LED indicators streamline installation and system troubleshooting
- 120V air cleaner output and 120V humidifier output up to 1 Amp max
- Factory standard safety timings and adjustable fan delay options
- Replaceable, automotive-style fuse

## Specifications

Low-voltage circuit ..... 24 VAC, 50 / 60 Hz  
 Line-voltage circuit ..... 120 VAC, 50 / 60 Hz  
 Circulator relay: PSC ..... 14.5 FLA - 25.0 LRA @ 120 VAC; 25A LRA @ 120 VAC  
 Circulator relay: ECMx ..... 4.0 mA RMS @ 18 VAC; 12.0 mA RMS @ 30 VAC  
 Operating temperature range ..... -40° to 175°F (-40° to 79°C)  
 Humidity range ..... 5% to 93% relative humidity (non-condensing)

## Direct OEM Replacement Integrated Furnace Controls

Family brands of equipment	Stages	Ignition type	Ignitor voltage	Induce motor / blower motor	Blower motor speed taps	Thermostat inputs	Includes ignitor or electrode	Twining	Includes wiring accessories	Comm system	Control mounting	Model number	Item number
Carrier	Single Stage	HSI	120 VAC	PSC/PSC	Heat, Cool, Fan	R, C, W, Y/Y2, Y1, G, DEHUM	—	√	√	—	Cover	50M56U-751	50M56U-751
Carrier	Single Stage	HSI	120 VAC	PSC/PSC	Heat, Cool, Fan	R, C, W, Y, G, DEHUM	—	√	√	—	Flush Mount	50M56D-751	50M56D-751
Carrier	Two-Stage	HSI	120 VAC	PSC/PSC, Var. speed/ECMx	Lo Heat, Hi Heat, Cool	R, COM 24 VAC, WW1, W2, Y1, Y/Y2, G, DHUM	—	√	√	—	Tray	21V51D-751	21V51D-751
Goodman	Single Stage	HSI	120 VAC	PSC/PSC	Heat, Cool	R, C, W, Y G	—	√	—	—	Standoff	50A55-743	50A55-743
Goodman	Single Stage	HSI	120 VAC	PSC/PSC	Heat, Cool	R, G, W	—	√	√	—	Standoff	50T35-743	50T35 743
Goodman	Single/Two Stage	HSI	120 VAC	PSC/PSC	Lo Heat, Hi Heat, Cool	R, C, W, Y G	—	—	√	—	Standoff	50M56-743	50M56-743
Goodman	Single Stage	HSI	120 VAC	PSC/PSC	Heat, Cool	R, C, W, Y, G	—	√	—	—	Standoff	50M56-707	50M56-707
Goodman	Two-Stage	HSI	120 VAC	Var. speed/Var. speed	4-wire Interface	1, 2, R, C, W1, W2, Y1, Y2, G, O DHUM	—	√	—	√	Standoff	50C51-707	50C51-707
Goodman	Two-Stage	HSI	120 VAC	ECMx	6-wire Interface	R, C, W1, W2, YLO, Y, G	—	√	√	—	Standoff	50M58-707	50M58-707
Lennox*	Single Stage	HSI	80 VAC only	PSC/PSC	Heat, Cool, Fan	R, C, W, Y G	—	—	√	—	Standoff/steel mounting BRKT (INCL)	21D83M-843	21D83M-843
Lennox	Single Stage	HSI	120 VAC	PSC/PSC	Heat, Cool, Fan	R, C, W, Y G	—	—	√	—	Standoff	50M56U-801	50M56U-801
Lennox*	Single Stage	HSI	80 VAC only	PSC/PSC	Heat, Cool, Fan	R, C, W, Y G	—	—	—	—	Standoff	50A66-743	50A66-743
Trane*	Single Stage	HSI	120 VAC	PSC/PSC	Heat, Cool	R, C, W, Y G	—	—	—	—	Standoff	50A55-3797	50A55-3797
Trane*	Single Stage	HSI	80 VAC only	PSC/PSC	Heat, Cool	R, C, W, Y G	—	√	—	—	Standoff	50A65-5165	50A65-5165
Trane	Two-Stage	HSI	120 VAC**	Var. speed/Var. speed	16-pin Interface	R, B/C W1, W2, Y, YLO, G, O, BK	√	√	√	—	Standoff	50V54-820	50V54-820
York	Single Stage	HSI	120 VAC	PSC/PSC	Heat, Lo Cool, Hi Cool	R, C, W, Y1, Y/Y2, G	—	√	—	—	Standoff/steel mounting BRKT (INCL)	50A56-956	50A56-956

\* Replaces White-Rodgers OEM Models.  
 \*\* On 80 VAC applications use supplied 21D64-2 Universal Ignitor.

# Non-Integrated Ignition Modules

Universal and direct OEM non-integrated controls for various applications that replace over 850 OEM and competitive part numbers.



50E47U-843

## Features

- Advanced 7-segment LED display for on-board configuration (program keys required on some models)
- Microprocessor-based ignition control
- Works with single-rod or dual-rod remote sensor
- Provides ignition, proof of ignition and precise timings
- LED diagnostic indicator
- For use in Natural and LP gas applications

## Specifications

Low voltage circuit.....	24 VAC, 50 / 60 Hz
Line voltage circuit.....	120 VAC, 50 / 60 Hz
Operating temp range.....	-40° to 175°F (-40° to 79°C)
Humidity range .....	5% to 95% relative humidity
.....	(non-condensing)

## Non-Integrated Ignition Modules

Family brands of equipment	Stages	Ignition type	Ignitor voltage	Thermostat inputs	Includes ignitor or electrode	Twimming	Includes wiring accessories	Mounting	Model number	Item number
Carrier, Goodman, Lennox, Trane, York	Single Stage	HSI	120 VAC	TH (W) , TR (C)	—	—	√	Surface mount or 4" x 4" junction box	50E47-843	50E47 843S1
Carrier, Goodman, Lennox, Trane, York, Pentair, StaRite, Jandy	Single Stage	HSI	24, 120, 240 VAC	TH (W) , TR (C)	—	—	√	Surface mount or 4" x 4" junction box	50E47U-8431	50E47U 843
Carrier, Lennox, Goodman, Rheem, Trane, York	Single Stage	Proven / Intermittent Pilot - Spark & Direct Spark	—	TH (W) , TR (C)	—	—	√	Surface mount or 4" x 4" junction box	50D50U-8431	50D50U 843
Lennox	Single Stage	Proven / Intermittent Pilot - Spark	—	TH (W) , TR (C)	√	—	√	Surface mount or 4" x 4" junction box or with steel bracket	50D50-801	50D50-801

<sup>1</sup> These ignition modules utilize the White-Rodgers Connect app for quick configuration and accurate diagnostics.

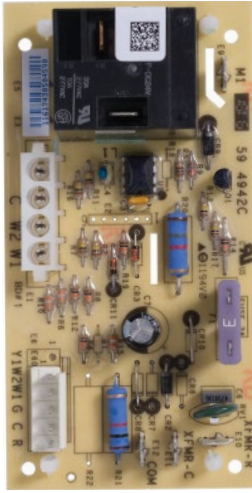
## Non-integrated cycle pilot relight control

Description	Input voltage	Electrical rating	Model number	Item number
Generates spark until pilot is lit spike connector	24 VAC	0.03 amps	5059-134	50 59 134S1

## Integrated thermostat sensor <sup>2</sup>

Description	Lead wire length (in)	Temperature tolerance	Model number	Item number
Integrated Temperature Sensor for select Ignition Modules	48	+/- 5% at 77 °F (25 °C)	F67-85352	F67-8535

<sup>2</sup> The integrated thermostat sensor when installed in the ignition module acts independently to maintain temperature without an external thermostat. For use on infrared heaters and tube heaters.



**48P21-811**

## Air Handler and Time Delay Controls

Variable speed, ECMx air handler and PSC blower time delay relay controls.

### Features

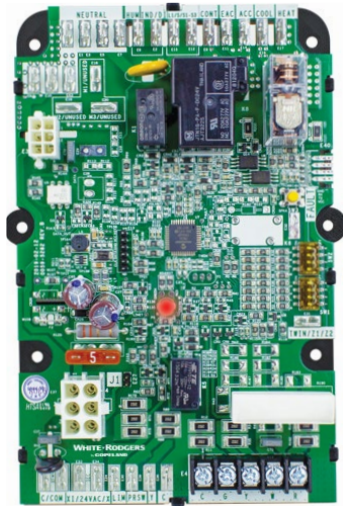
- Goodman style controls for communicating or legacy systems
- Trane style single stage blower time delay relay for PSC inducer and blower allows residual cooled air to be blown into the controlled space, increasing efficiency
- Rheem single stage air handler controls available for both PSC and ECMx blower motors
- Carrier controls offer a selectable fan off delay switch of 0 or 90 seconds

### Specifications

Operating temperature range..... -40 to 175°F (-40 to 79°C)  
 Input voltage..... 24 VAC 50/60 Hz  
 Input voltage (48C21-707)..... 24 VAC 60 Hz

#### Air Handler and Time Delay Controls

Oem direct replacement	Description	Blower Motor	Mounting	Blower motor speed taps	Thermostat Inputs	Additional wiring accessories	Communicating system	Model number	Item number
Carrier	Single Stage Air Handler	PSC or ECMx	Metal Standoff	1	R, C, G, W	—	—	48M55-751	48M55-751
Carrier	Single Stage Air Handler	PSC	Metal Standoff	1	R, C, G, W	—	—	48P55-751	48P55-751
Goodman	Two-Stage Air Handler	Variable Speed	Standoff	4-wire Interface	1, 2, R, C, W1, W2, Y1, Y2, G, O, DEHUM	—	√	48C21-707	48C21-707
Rheem	Single Stage Air Handler	PSC	Standoff	M1, Fan	R, C, G, W1, W2, Y1	√	—	48P21-811	48P21-811
Rheem	Single Stage Air Handler	ECMx	Standoff	X13 SPD, X13 G, COM	X13 SPD, X13 G, COM	—	—	48X21-811	48X21-811
Trane	Single Stage Time Delay	PSC	Metal Plate	—	—	—	—	57T01-843	57T01-843



**50F06-843**

## Universal Furnace Electronic Fan Timer

The 50F06-843 is an aftermarket universal replacement fan timer control for single stage furnaces with PSC inducer and blower motors. Works with non-integrated furnace controls or intelligent valves.

### Features

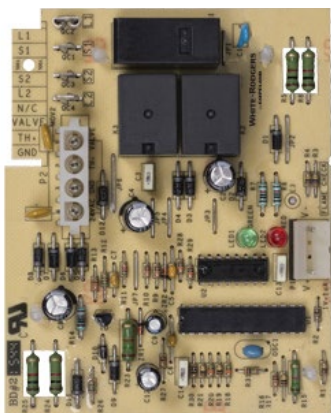
- Six mounting hole options that works with 2 or 4 screw configurations
- Harnesses with terminal flags for easy wiring
- Terminals are labeled to match multiple existing boards
- Transformer connections offer 1/4" and 3/16" terminals
- Tri-Color LED displays status and fault codes
- Exclusive fault recall button

### Specifications

Ambient operating temperature..... -40 to 175°F (-40 to 79°C)  
 Humidity range..... 5% to 95% relative humidity (non-condensing)  
 Dimensions..... 5.0"W x 7.0"L x 1.50"D

#### Universal Furnace Electronic Fan Timer

Description	Input low voltage	Input line voltage	Max input current	Blower motor	Model number	Item number
Universal Electronic Fan Timer for non-integrated single stage furnaces. Replaces Honeywell ST9120U1011, ICM270, and Robertshaw 695-003	25 VAC 60 Hz	115/230 VAC, 60 Hz	800mA @ 25 VAC	PSC	50F06-843	50F06-843



50E70-820

## Commercial rooftop and package unit

For Trane Integrated and Non-Integrated ignition, single and two stage.

### Features

- For Trane Integrated and Non-Integrated ignition, single and two stage
- Direct replacement and adapter board style controls
- For Hot Surface Ignition and Direct Spark systems
- Integrated models control fan functions Non-Integrated models provide burner supervision

### Specifications

Operating voltage..... 18 to 30 VAC  
 Operating temperature range..... -40° to 175°F (-40° to 79°C)  
 Humidity range ..... 0 to 95% relative humidity (non-condensing)

### Commercial rooftop & package unit

Family brands of equipment	Stages	Control type	Ignition type	Ignitor voltage	Inducer motor / blower motor	Blower motor speed taps	Thermostat Inputs	Includes wiring accessories	Control mounting	Model number	Item number
trane	Single Stage	Non-Integrated Ignition Module	HSI	120 VAC	PSC / PSC	—	System 4 Pin Connector	√	Stand-Offs / Adapter Board	50E70-820	50E70-820
Trane	Two-Stage	Integrated Furnace Control 80 Second Time Delay	Direct Spark	—	PSC / PSC	Hi, Low	R (24 VAC), B (GND), W1, W2, Y, G	—	Stand-Offs / Adapter Board	50N02A-820	50N02A-820
Trane	Two-Stage	Integrated Furnace Control 45 Second Time Delay	Direct Spark	—	PSC / PSC	Hi, Low	R (24 VAC), B (GND), W1, W2, Y, G	—	Stand-Offs / Adapter Board	50N02B-820	50N02B-820
Trane	—	Adapter Board for 50N02A or B Controls	—	—	—	—	—	√	Adapter Board	F50N02-820	F50N02-820



36C01A-405

## 36C Series Universal Standing Pilot

Universal replacements for Standing Pilot systems

### Features

- Line interrupter styles use standard 30 mV thermocouples
- Straight through design with side tapped models available
- Inlet / outlet reducer bushings included on select models
- Mounting position upright, or 0° to 90° from upright in any direction

### Specifications

Electrical rating.....	0.23 amps
Ambient operating range.....	-40 to 175°F (-40 to 79°C)
Maximum pressure rating.....	1/2" PSI (14.0" WC)
Pilot gas connection.....	Compression fitting for 1/4" OD tubing
Inlet & outlet pressure taps.....	1/8" NPT
UR/CUR file number.....	MP1323
CSA/CUS certificate number.....	1113449

Pipe size	1" Pressure drop capacity natural gas .64 Sp. Gr. (1000 Btu/ft3)	1" Pressure drop capacity LP gas 1.53 Sp. Gr. (2500 Btu/ft3)	Range of regulation Natural gas .64 Sp. Gr. (1000 Btu/ft3)	Range of regulation LP gas 1.53 Sp. Gr. (2500 Btu/ft3)
1/2" X 3/8"	100,000	162,000	15,000-100,000	15,000-162,000
1/2" X 1/2"	230,000	372,600	30,000-290,000	30,000-469,000
1/2" X 3/4"	230,000	372,600	30,000-290,000	30,000-469,000
3/4" X 3/4"	280,000	453,600	50,000-400,000	50,000-648,000

### 36C Series Universal Standing Pilot

Voltage	Stages / opening	Pipe size	Regulator setting	Natural gas adj. range (vc)	LP gas adj. range (vc)	LP kit included	Reducer bushing kit	Flow direction	Side taps	Inlet / outlet pressure tap	Standing pilot with line interrupter	Internal wiring see figure	Model number	Item number
120 VAC 60 Hz	1 - Stage Fast Open	3/4" x 3/4"	3.5"	2.5"-5.0"	7.5"-12.0"	Yes	Yes	Str. Thru	No	No / Yes	Yes	3	36C03A-410	36C03A410S1
120 VAC 60 Hz	1 - Stage Fast Open	3/4" x 3/4"	3.5"	2.5"-5.0"	4.2"-11.0"	Yes	Yes	Str. Thru	No	No / Yes	Yes*	3	36C01A-405	36C01A405S1
24 VAC 60 Hz	1 - Stage Fast Open	1/2" X 3/4"	3.5"	2.5"-5.0"	7.5"-12.0"	Yes	Yes	Str. Thru	No	No / Yes	Yes	1	36C03-300	36C03-300
24 VAC 60 Hz	1 - Stage Fast Open	1/2" X 3/4"	3.5"	2.5"-5.0"	7.5"-12.0"	Yes	Yes	Str. Thru	Yes	Yes / Yes	Yes	1	36C03-333	36C03-333
24 VAC 60 Hz	1 - Stage Fast Open	3/4" x 3/4"	3.5"	2.5"-5.0"	7.5"-12.0"	Yes	Yes	Str. Thru	No	Yes / Yes	Yes	1	36C03-400	36C03-400
24 VAC 60 Hz	1 - Stage Fast Open	3/4" x 3/4"	3.5"	2.5"-5.0"	7.5"-12.0"	Yes	Yes	Str. Thru	Yes	Yes / Yes	Yes	1	36C03-433	36C03-433

36c series universal standing pilot (continued)





Voltage	Stages / opening	Pipe size	Regulator setting	Natural gas adj. range (wc)	LP gas adj. range (wc)	LP kit included	Reducer bushing kit	Flow direction	Side taps	Inlet / outlet pressure tap	Standing pilot with line interrupter	Internal wiring see figure	Model number	Item number
24 VAC 60 Hz	1 - Stage Fast Open	3/4" x 3/4"	3.5"	2.5"-5.0"	7.5"-12.0"	No **	Yes	Str. Thru	No	No / Yes	Yes	1	36C53-418	36C53 418S1
24 VAC 60 Hz	1 - Stage Fast Open	1/2" X1/2"	3.5"	2.5"-5.0"	7.5"-12.0"	No	No	Str. Thru	No	Yes / Yes	Yes	1	36C03-258	36C03 258S1
750 mV	1 - Stage Fast Open	1/2" X 3/4"	3.5"	2.5"-5.0"	7.5"-12.0"	Yes	Yes	Str. Thru	Yes	Yes / Yes	Yes	2	36C03U-333	36C03U-333
750 mV	1 - Stage Fast Open	3/4" x 3/4"	3.5"	2.5"-5.0"	7.5"-12.0"	Yes	Yes	Str. Thru	Yes	Yes / Yes	Yes	2	36C03U-433	36C03U-433

NOTE: Not for HSI / DSI / Intermittent / Proven Pilot.

\* 36C01A-405 has pilot port but no thermocouple line interrupter.

\*\* 36C53-418 order F92-0659 Nat. to LP conversion kit for 7.5"-12.0" range. See White-Rodgers General Information for capacities of other gases.

Parts and accessories

Image	Description	Model number	Item number
	Brass Compression Fitting for 1/4" Pilot Line Connections 7/16"-24 Thread	F69-0727	F0069 072700S1
	LP to Natural Gas Conversion Kit for Use On Single Stage 36C, D, E, F, G, H, J Valves, Regulation Range 2.5" to 5.0"W.C.	F92-0656	F0092 065600S1
	Natural to Regulated LP Gas Conversion Kit for Use On Single Stage 36C, D, E, F, G, H, J Valves. Regulation Range 7.0" to 12.0"W.C.	F92-0659	F0092 065900S1
	Natural to Unregulated LP Gas Conversion Kit for All 36C00 Valves. Use With External Regulator Set for LP Gas	F92-0737	F0092 073700S1



36C94-303

# 36C Series HSI / DSI / Intermittent / Proven Pilot

Ideal general purpose replacements for Intermittent Ignition systems.

## Features

- Straight through design
- Inlet / outlet reducer bushings included
- Mounting position upright, or 0° to 90° from upright in any direction
- Special Intermittent Ignition Device model for two-stage applications (36C74-913)

## Specifications

Electrical rating..... 0.6 amps  
 Ambient operating range..... -40 to 175°F (-40 to 79°C)  
 Maximum pressure rating..... 1/2" PSI (14.0" WC)  
 Pilot gas connection ..... Compression fitting for 1/4" OD tubing  
 Inlet & outlet pressure taps..... 1/8" NPT  
 UR/CUR file number..... MP1323  
 CSA/CUS certificate number..... 1113449

Pipe size	1" Pressure drop capacity natural gas .64 Sp. Gr. (1000 Btu/ft3)	1" Pressure drop capacity LP gas 1.53 Sp. Gr. (2500 Btu/ft3)	Range of regulation natural gas .64 Sp. Gr.(1000 Btu/ft3)	Range of regulation LP gas 1.53 Sp. Gr. (2500 Btu/ft3)
1/2" X 3/8"	100,000	162,000	15,000-100,000	15,000-162,000
1/2" X 1/2"	230,000	372,600	30,000-290,000	30,000-469,000
1/2" X 3/4"	230,000	372,600	30,000-290,000	30,000-469,000
3/4" X 3/4"	280,000	453,600	50,000-400,000	50,000-648,000

### 36C Series HSI / DSI, Intermittent / Proven Pilot

Voltage	Stages / opening	Pipe size	Regulator setting	Natural gas adj. Range (wc)	LP gas adj. Range (wc)	LP kit Included	Reducer bushing kit	Flow direction	Side taps	Inlet / outlet pressure tap	HSI / DSI	Intermittent / proven pilot	Internal wiring see figure	Model number	Item number
24 VAC 60 Hz	Step Open	3/4" x 3/4"	0.9"/3.5"	2.5"-5.0"	Nat. Only	No	Yes	Str. Thru	No	Yes / Yes	Yes	Yes	5	36C74-913	36C74-913

### 36C Series Intermittent / Proven Pilot

24 VAC 60 Hz	Delay Slow	1/2" X 3/4"	3.5"	2.5"-5.0"	7.5"-12.0"	Yes	No	Str. Thru	No	Yes / Yes	No	Yes	15	36C94-303	36C94-303
--------------	------------	-------------	------	-----------	------------	-----	----	-----------	----	-----------	----	-----	----	-----------	-----------

NOTE: Not for Standing Pilot.

### Parts and accessories

Image	Description	Model number	Item number
	Brass Compression Fitting for 1/4" Pilot Line Connections 7/16"-24 Thread	F69-0727	F0069 072700S1
	LP to Natural Gas Conversion Kit for Use On Single Stage 36C, D, E, F, G, H, J Valves, Regulation Range 2.5" to 5.0"W.C.	F92-0656	F0092 065600S1
	Natural to Regulated LP Gas Conversion Kit for Use On Single Stage 36C, D, E, F, G, H, J Valves. Regulation Range 7.0" to 12.0"W.C.	F92-0659	F0092 065900S1
	Natural to Unregulated LP Gas Conversion Kit for All 36C00 Valves. Use With External Regulator Set for LP Gas	F92-0737	F0092 073700S1



36C84-912

# 36C Cycle Pilot Gas Valves

Ideal general purpose replacements for Cycle-Pilot Intermittent Ignition systems

## Features

- Straight through design
- Mounting position upright, or 0° to 90° from upright in any direction
- Inlet/outlet reducer bushings

## Specifications

Electrical rating..... 0.6 amps  
 Maximum pressure rating..... 1/2 PSI (14.0" W.C.)  
 Ambient operating range..... -40 to 175°F (-40 to 79°C)  
 UR/CUR file number..... MP1323  
 CSA/CUS certificate number..... 1113449

Pipe size	1" Pressure drop capacity		Range of regulation	
	BTU/hr		BTU/hr	
	1" Pressure drop capacity natural gas .64 Sp. Gr. (1000 Btu/ft3)	1" Pressure drop capacity LP gas 1.53 Sp. Gr. (2500 Btu/ft3)	Range of regulation natural gas .64 Sp. Gr. (1000 Btu/ft3)	Range of regulation LP gas 1.53 Sp. Gr. (2500 Btu/ft3)
1/2" X 3/8"	100,000	162,000	15,000-100,000	15,000-162,000
1/2" X 1/2"	230,000	372,600	30,000-290,000	30,000-469,000
1/2" X 3/4"	230,000	372,600	30,000-290,000	30,000-469,000
3/4" X 3/4"	280,000	453,600	50,000-400,000	50,000-648,000

## 36C Series Cycle Pilot

Voltage	Stages / opening	Pipe size	Regulator setting	Natural gas adj. range (wc)	LP gas adj. range (wc)	LP kit Incl	Reducer bushing kit	Flow direction	Side taps	Inlet / outlet pressure tap	Intermittent / proven pilot	Internal wiring see figure	Model number	Item number
24 VAC 60 Hz	1 - Stage Fast Opening	3/4" x 3/4"	3.5"	2.5"-5.0"	7.5"-12.0"	Yes	Yes	Str. Thru	No	Yes / Yes	Cycle Pilot	7	36C84-912	36C84 912
24 VAC 60 Hz	1 - Stage Fast Opening	3/4" x 3/4"	3.5"	2.5"-5.0"	7.5"-12.0"	Yes	Yes	Str. Thru	No	Yes / Yes	Cycle Pilot	7	36C84-921	36C84 921
24 VAC 60 Hz	1 - Stage Fast Opening	3/4" x 3/4"	3.5"	2.5"-5.0"	Nat. Only	No	No	Str. Thru	No	Yes / Yes	Cycle Pilot	14	36C84-923	36C84 923
24 VAC 60 Hz	1 - Stage Fast Opening	3/4" x 3/4"	3.5"	2.5"-5.0"	Nat. Only	No	Yes	Str. Thru	No	No / No	Cycle Pilot	4	36C84-926	36C84 926
24 VAC 60 Hz	1 - Stage Fast Opening	3/4" x 3/4"	3.5"	2.5"-5.0"	7.5"-12.0"	Yes	Yes	Str. Thru	No	Yes / Yes	Cycle Pilot	8	36C84-945	36C84 945
24 VAC 60 Hz	1 - Stage Fast Opening	3/4" x 3/4"	3.5"	2.5"-5.0"	Nat. Only	No	Yes	Str. Thru	No	Yes / Yes	Cycle Pilot	7	36C94-906	36C94 906

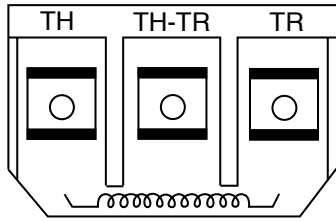
NOTE: Not for Standing Pilot / HSI / DSI.  
 NOTE: -9XX series replaces -4XX series. Knob replaced with an ON-OFF switch.  
 See White-Rodgers General information for capacities of other gases.

## Parts and accessories

Image	Description	Model number	Item number
	Bracket for Bryant pilots when retrofitting with Cycle-Pilot®.	F6-1794	F0006 179400B1
	LP to Natural Gas Conversion Kit for Use On Single Stage 36C, D, E, F, G, H, J Valves, Regulation Range 2.5" to 5.0"W.C.	F92-0656	F0092 065600S1
	Natural to Regulated LP Gas Conversion Kit for Use On Single Stage 36C, D, E, F, G, H, J Valves. Regulation Range 7.0" to 12.0"W.C.	F92-0659	F0092 065900S1
	Natural to Unregulated LP Gas Conversion Kit for All 36C00 Valves. Use With External Regulator Set for LP Gas	F92-0737	F0092 073700S1

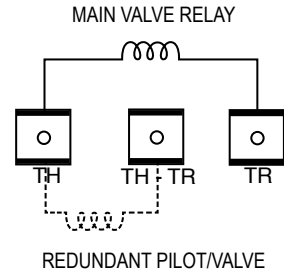
Image	Description	Model number	Item number
	Gas valve pilot fitting 1/4" brass compression fitting for pilot line connections.	F69-0727	F0069 072700S1
	36" replacement harness assembly for connection of 5059-23 to 36C84-426 in the 21D18-3 Cycle-Pilot® retrofit kit.	F115-0064	F0115 006400S1
	36" replacement harness assembly for connection of 5059-23 to 36E86- 302 in the 21D18-14 Cycle-Pilot® retrofit kit.	F115-0087	F0115 008700

3 Terminal panel



Some models have screw terminals instead of spade terminals shown

FIG. 1



Some models may not have redundant valve

Millivolt 3 terminal panel

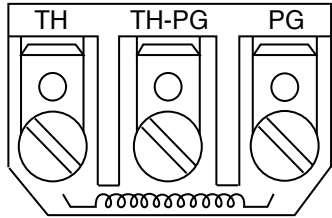
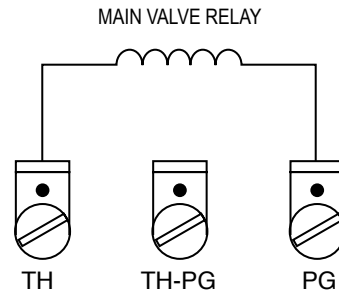


FIG. 2



Snap open

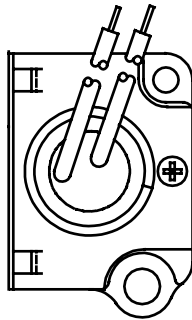
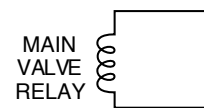


FIG. 3



Cycle pilot

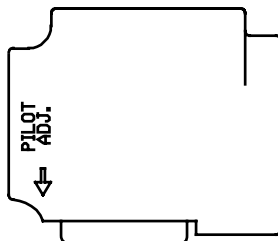
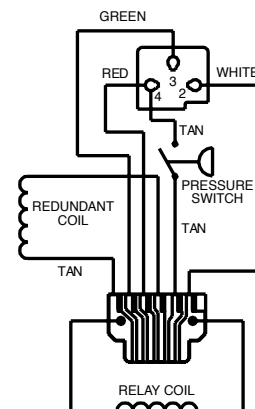


FIG. 4



4 Terminal panel

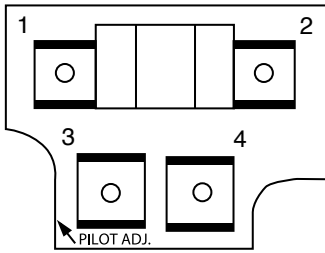
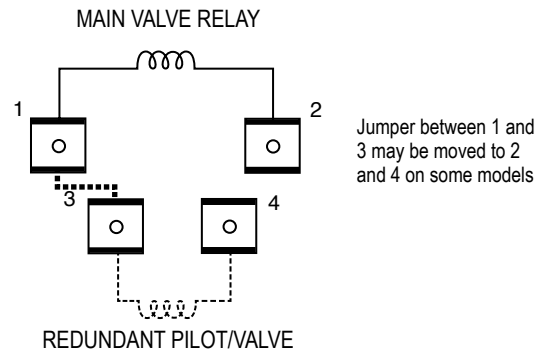
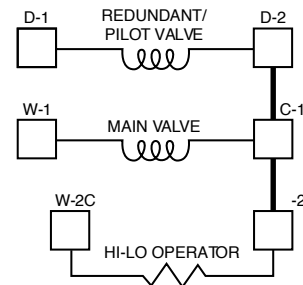
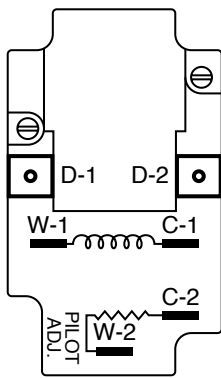


FIG. 5



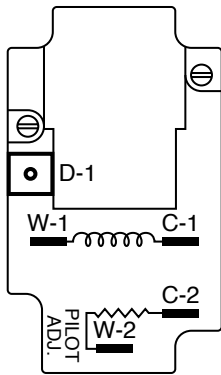
Bi-metal two stage

FIG. 6A

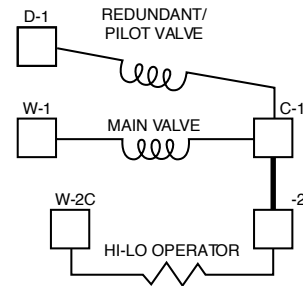


Bi-metal two stage

FIG. 6B

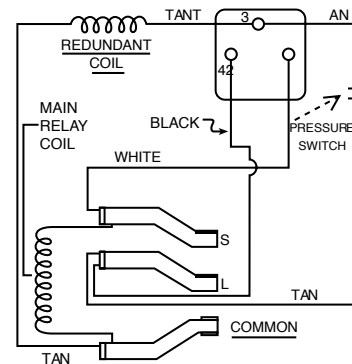
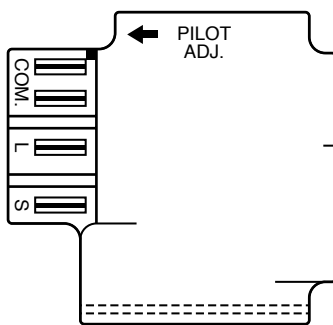


On some models, W1 and W2 are designated GV1 and GV2



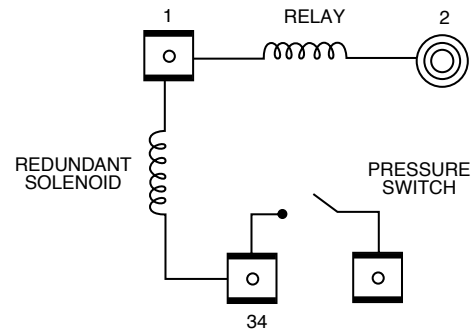
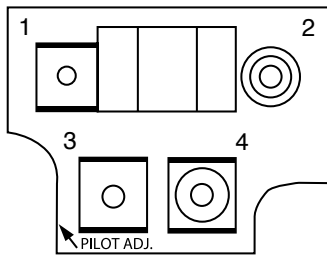
Cycle pilot plug-in

FIG. 7



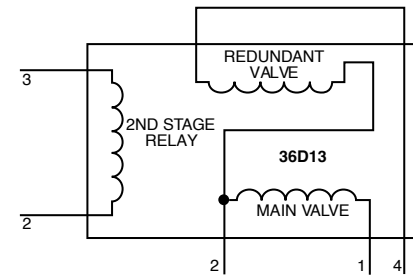
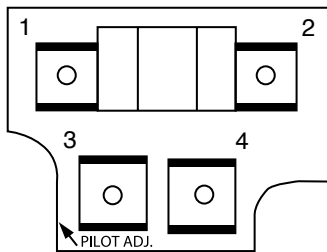
Cycle pilot with 4 terminal panel

FIG. 8



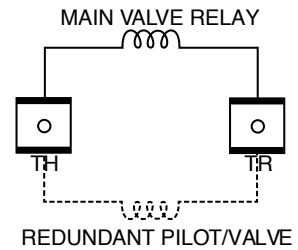
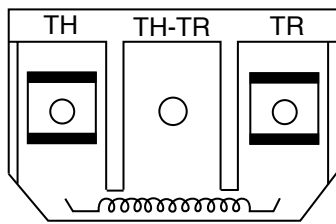
Relay two stage

FIG. 9



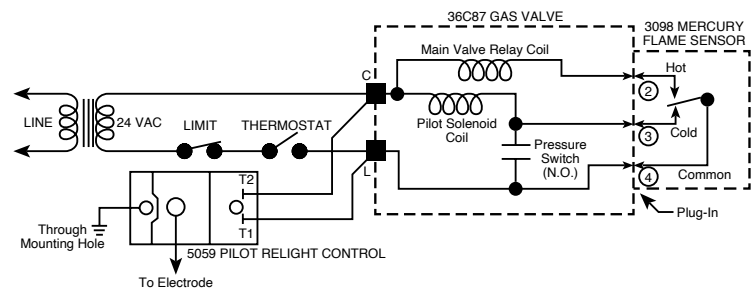
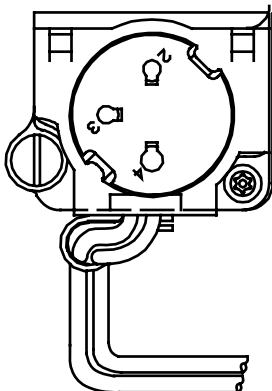
2 Terminal panel

FIG. 10



Cycle pilot

FIG. 11



Cycle pilot

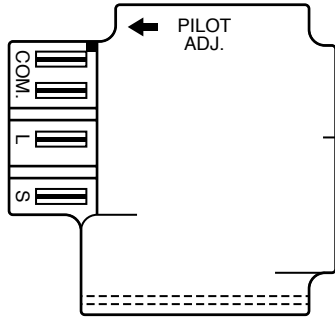
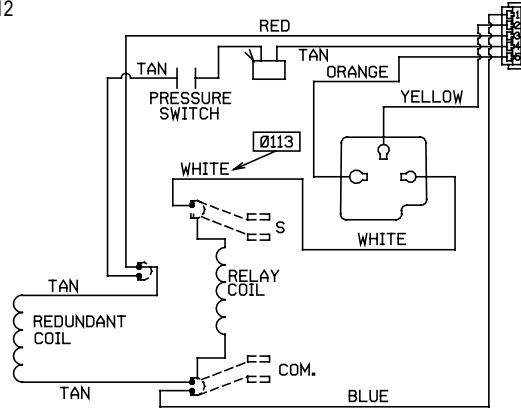


FIG. 12



Cycle pilot

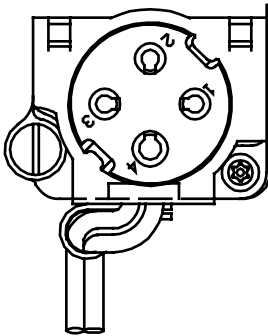
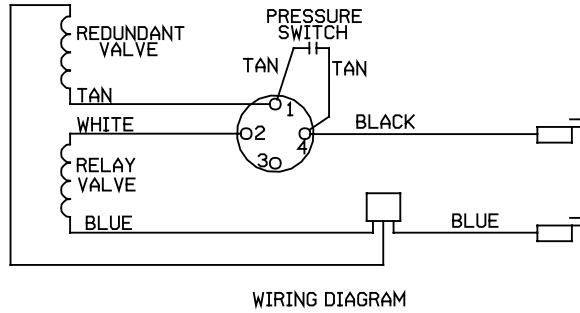


FIG. 13



Cycle pilot

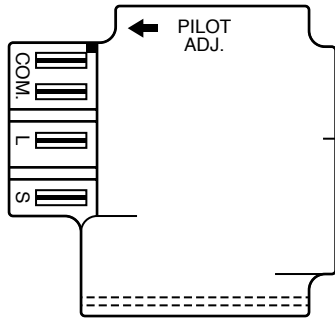
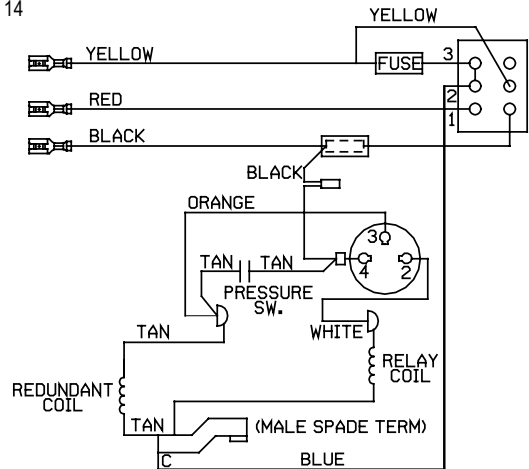


FIG. 14



Intermittent ignition

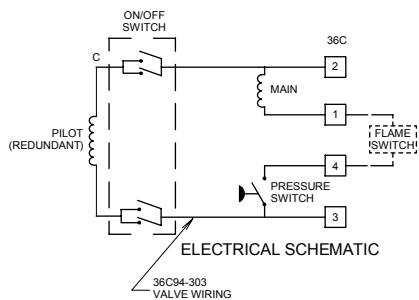
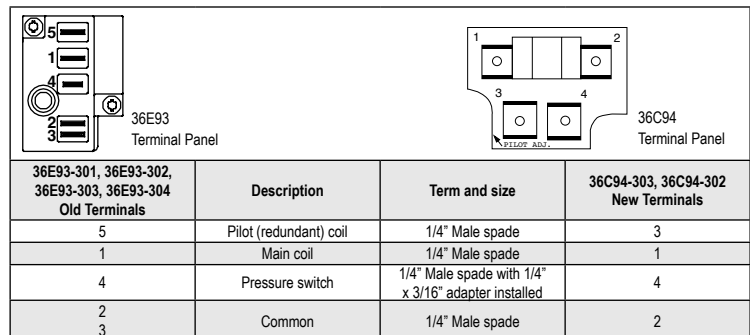


FIG. 15





36H32-423

## 36H Series HSI / DSI / Intermittent / Proven Pilot

Universal electronic ignition gas valves. Our highest capacity multi-function combination control covering a wide range of gas heating applications.

### Features

- Pilot port plugged for Hot Surface and Direct Spark Ignition systems, remove plug for Intermittent / Proven Pilot systems
- Fast open, slow open, single and two stage models
- Electric on-off switch and convenient quick connect coil terminals
- Tamper resistant screws and controlled gasket compression to withstand high inlet pressures
- Mounting position upright, or 0° to 90° from upright in any direction

### Specifications

Operating voltage.....	24 VAC 50/60 Hz
Electrical rating - single stage .....	0.41 amps
Electrical rating - two stage .....	0.54 amps
Ambient operating range .....	-40 to 175°F (-40 to 79°C)
Maximum pressure rating.....	1/2" PSI (14.0" WC)
CSA/CUS certificate number .....	1636373

Pipe size	1" Pressure drop capacity Natural gas .64 Sp. Gr. (1000 Btu/ft <sup>3</sup> )	1" Pressure drop capacity LP gas 1.53 Sp. Gr. (2500 Btu/ft <sup>3</sup> )	Range of regulation Natural gas.64 Sp. Gr. (1000 Btu/ft <sup>3</sup> )	Range of regulation LP gas1.53 Sp. Gr. (2500 Btu/ft <sup>3</sup> )
3/4" x 3/4"	300,000	486,000	50,000-400,000	81,000-648,000
1/2" x 3/4"	230,000	372,600	50,000-300,000	80,000-500,000
1/2" x 1/2"	170,000	275,500	40,000-240,000	40,000-400,000

### 36H Series HSI / DSI / Intermittent / Proven Pilot

Voltage	Stages / opening	Pipe size	Regulator setting	Natural gas adj. range (wc)	LP gas adj. range (wc)	Lp kit included	Reducer bushing kit	Flow direction	Side taps	Inlet / outlet pressure tap*	Hsi / dsi Intermittent / proven pilot	Internal wiring see figure	Model number	Item number
24 VAC 50/60Hz	1 - Stage Fast Open	1/2" X 1/2"	3.5"	2.5"-5.0"	5.0"-12.0"	Yes	No	Str. Thru	No	Yes / Yes	Yes	1	36H32-214	36H32-214
24 VAC 50/60Hz	1 - Stage Fast Open	1/2" X 3/4"	3.5"	2.5"-5.0"	5.0"-12.0"	Yes	Yes	Str. Thru	No	Yes / Yes	Yes	1	36H32-304	36H32-304
24 VAC 50/60Hz	1 - Stage Fast Open	3/4" X 3/4"	3.5"	2.5"-5.0"	5.0"-12.0"	Yes	Yes	Str. Thru	No	Yes / Yes	Yes	1	36H32-423	36H32-423
24 VAC 50/60Hz	1 - Stage Slow Open	3/4" X 3/4"	3.5"	2.5"-5.0"	5.0"-12.0"	Yes	Yes	Str. Thru	No	Yes / Yes	Yes	1	36H33-412	36H33-412
24 VAC 50/60Hz	2 - Stage Fast Open	3/4" X 3/4"	1.1" Low 3.5" High	1.0"-3.5" Low 2.5"-5.0" High	4.0"-9.5" Low 8.0"-12.0" High	Yes	Yes	Str. Thru	No	Yes / Yes	Yes	1	36H64-463	36H64-463
24 VAC 50/60Hz	2 - Stage Slow Open	3/4" X 3/4"	1.1" Low 3.5" High	1.0"-3.5" Low 2.5"-5.0" High	4.0"-9.5" Low 8.0"-12.0" High	Yes	Yes	Str. Thru	No	Yes / Yes	Yes	1	36H65-401	36H65-401

\* To measure outlet pressure on valves, loosen outlet pressure tap screw one quarter turn and put manometer hose over the top of the outlet pressure tap.

See White-Rodgers General Information for capacities of other gases.

NOTE: Not for Standing Pilot.

Parts and accessories




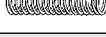


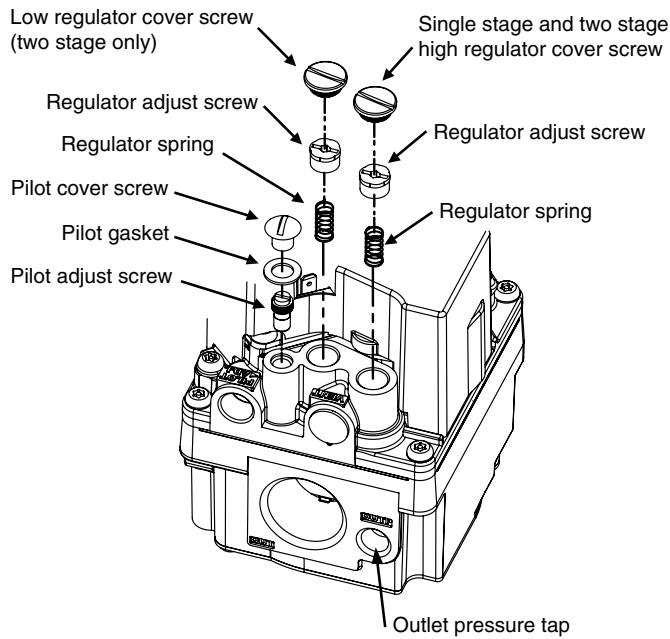
Image	Description	Model number	Item number
	LP to Natural Gas Conversion Kit for Use On Single Stage 36C, D, E, F, G, H, J Valves. Regulation Range 2.5" to 5.0"W.C.	F92-0656	F0092 065600S1
	Natural to Regulated LP Gas Conversion Kit for Use On Single Stage 36C, D, E, F, G, H, J Valves. Regulation Range 7.0" to 12.0"W.C.	F92-0659	F0092 065900S1

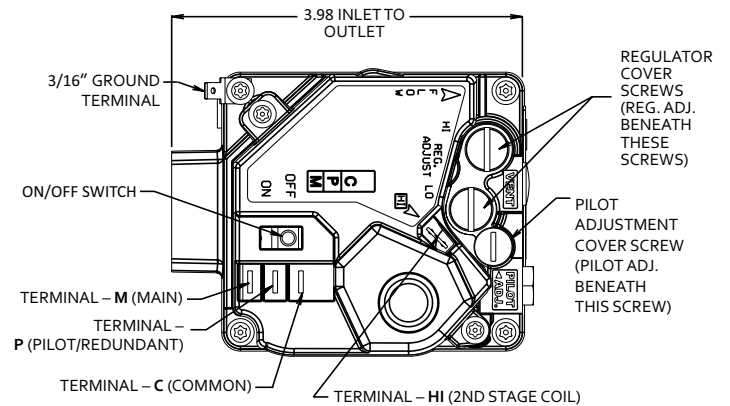
Image	Description	Model number	Item number
 	Natural to Regulated LP Gas Conversion Kit for Use On Two Stage 36G, H, J, Valves. Regulation Range 4.0" to 10.0"W.C. Low Fire, 6.0" to 12.0"W.C. High Fire	F92-1008	F0092 100800
 	Regulated LP to Natural Gas Conversion Kit for Use On Two Stage 36G, H, J, Valves. Regulation Range 1.0" to 4.0"W.C. Low Fire, 2.0" to 5.0"W.C. High Fire	F92-1011	F0092 101100

36H WIRING INFORMATION

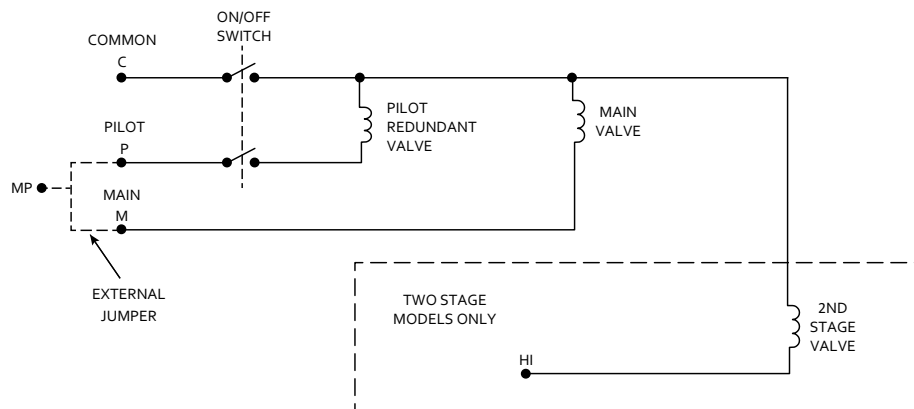
Simplified gas valve internal wiring and terminal identification



Single and two stage



Features and terminal identification





36G22-254

# 36G / J Series HSI / DSI / Intermittent / Proven Pilot

Electronic ignition gas valve. The versatile 36G/36J series combination gas valve covers a wide range of applications. Designed for use with common ignition systems (HSI/DSI/ Intermittent/Proven Pilot). This series is our most compact footprint combination gas valve.

## Features

- Designed for hot surface, direct spark and intermittent pilot ignition systems and features a compact footprint and versatile range
- Fast open, slow open, single and two stage models
- Electric on-off switch and convenient quick connect coil terminals and built-in pressure taps
- Tamper resistant screws and controlled gasket compression to withstand high inlet pressures
- Mounts in any position including upside down

## Specifications

Operating voltage..... 24 VAC 50/60 Hz  
 Electrical rating - single stage ..... .3 amps  
 Electrical rating - two stage ..... .43 amps  
 Ambient operating range ..... -40 to 175°F (-40 to 79°C)  
 Maximum pressure rating..... 1/2" PSI (14.0" WC)  
 CSA/CUS certificate number ..... 1175379  
 ..... CE (36J)

Valve (stages)	Pipe size	1" Pressure drop capacity		Range of regulation	
		Natural gas .64 Sp. Gr. (1000 Btu/ft3)	LP gas 1.53 Sp. Gr. (2500 Btu/ft3)	Natural gas .64 Sp. Gr. (1000 Btu/ft3)	LP gas 1.53 Sp. Gr. (2500 Btu/ft3)
Single	1/2" x 1/2"	140,000	226,800	40,000-210,000	60,000-340,000
Two	1/2" x 1/2"	140,000	226,800	20,000 Low-210,000 High	32,000 Low-340,000 High
Modulating	1/2" x 1/2"	140,000	226,800	20,000-210,000	32,600-340,000

## 36G / J Series HSI / DSI / Intermittent / Proven Pilot

Voltage	Stages / opening	Pipe size	Regulator setting	Natural gas adj. Range (wc)	Lp gas adj. Range (wc)	Lp kit included	Reducer bushing kit	Flow direction	Side taps	Inlet / outlet Pressure tap	HSI / DSI	Intermittent / Proven pilot	Flange mount capable	Model number	Item number
24 VAC 50/60Hz	1 - Stage Fast Open	1/2" X 1/2"	3.5"	2.5"-5.0"	7.0"-12.0"	No**	No	Str. Thru	No	Yes / Yes*	Yes	No	No	36G22-254	36G22-254
24 VAC 50/60Hz	1 - Stage Fast Open	1/2" X 1/2"	3.5"	2.5"-5.0"	7.0"-12.0"	Yes	No	Str. Thru	No	Yes / Yes* NPT & Towers	Yes	Yes	Yes	36G32-500	36G32-500
24 VAC 50/60Hz	1 - Stage Slow Open	1/2" X 1/2"	3.5"	2.5"-5.0"	7.0"-12.0"	Yes	No	Str. Thru	No	Yes / Yes* NPT & Towers	Yes	Yes	Yes	36G33-500	36G33-500
24 VAC 50/60Hz	1 - Stage Fast Open	1/2" X 1/2"	3.5"	2.5"-5.0"	7.0"-12.0"	Yes	Yes	Str. Thru	No	Yes / Yes	Yes	No	No	36J22-214	36J22-214
24 Vac 50/60Hz	1 - Stage Fast Open	1/2" X 1/2"	3.5"	2.5"-5.0"	7.0"-12.0"	Yes	No	Str. Thru	No	Yes / Yes	Yes	No	No	36J22Y-212	36J22Y-212
24 VAC 50/60Hz	1 - Stage Slow Open	1/2" X 1/2"	3.5"	2.5"-5.0"	7.0"-12.0"	Yes	Yes	Str. Thru	No	Yes / Yes	Yes	No	No	36J24-214	36J24-214

\* NOTE: Not for Standing Pilot.  
 \*\* To measure outlet pressure on valves, loosen outlet pressure tap screw one quarter turn and put manometer hose over the top of the outlet pressure tap. Use F92-0659 to convert to regulated L.P. gas. See White-Rodgers General Information for capacities of other gases.

## 36G / J series HSI / DSI / Intermittent / Proven Pilot &lt;cont'd&gt;

Voltage	Stages / opening	Pipe size	Regulator setting	Natural gas adj. Range (wc)	Lp gas adj. Range (wc)	Lp kit included	Reducer bushing kit	Flow direction	Side taps	Inlet / outlet Pressure tap	HSI / dsi	Intermittent / Proven pilot	Flange mount capable	Model number	Item number
24 VAC 50/60Hz	Modulating	1/2" X 1/2"	3.5"	0.4"-4.0"	1.3"-11.5"	Yes	Yes	Str. Thru	No	Yes / Yes	Yes	No	No	36J27-554	36J27-554
24 VAC 50/60Hz	2 - Stage Fast Open	1/2" X 1/2"	1.5" Low 3.5" High	1.0"-4.0" Low 2.0"-5.0" High	4.0"-10.0" Low 6.0"-12.0" High	Yes	Yes	Str. Thru	No	Yes / Yes*	Yes	No	No	36J54-214	36J54-214
24 VAC 50/60Hz	2 - Stage Slow Open	1/2" X 1/2"	1.5" Low 3.5" High	1.0"-4.0" Low 2.0"-5.0" High	4.0"-10.0" Low 6.0"-12.0" High	Yes	Yes	Str. Thru	No	Yes / Yes*	Yes	No	No	36J55-214	36J55-214
24 VAC 50/60Hz	1 - Stage Slow Open	1/2" X 1/2"	3.5"	2.5"-5.0"	7.0"-12.0"	Yes	No	90° Bottom Outlet	No	Yes / Yes*	Yes	No	No	36J24-614	36J24-614
24 VAC 50/60Hz	2 - Stage Slow Open	1/2" X 1/2"	1.5" Low 3.5" High	1.0"-4.0" Low 2.0"-5.0" High	4.0"-10.0" Low 6.0"-12.0" High	Yes	No	90° Bottom Outlet	No	Yes / Yes*	Yes	No	No	36J55-614	36J55-614

NOTE: Not for Standing Pilot / Intermittent / Proven Pilot.

See White-Rodgers General Information for capacities of other gases.

- \* To measure outlet pressure on valves, loosen outlet pressure tap screw one quarter turn and put manometer hose over the top of the outlet pressure tap.
- \*\* Use F92-0659 to convert to regulated L.P. gas.

## Parts and accessories

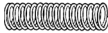


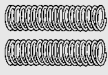
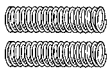
Image	Description	Model number	Item number
	LP to Natural Gas Conversion Kit for Use On Single Stage 36C, D, E, F, G, H, J Valves, Regulation Range 2.5" to 5.0"W.C.	F92-0656	F0092 065600S1
	Natural to Regulated LP Gas Conversion Kit for Use On Single Stage 36C, D, E, F, G, H, J Valves. Regulation Range 7.0" to 12.0"W.C.	F92-0659	F0092 065900S1
	Adapter Kit for The 36G Gas Valves. Kit Includes: Connector (5/16" to 1/4" Hose Barb), Tube (5/16" O.D.) and Hex Wrench (3/32")	F92-1003	F0092 100300S1
	Natural to Regulated LP Gas Conversion Kit for Use On Two Stage 36G, H, J, Valves, Regulation Range 4.0" to 10.0"W.C. Low Fire, 6.0" to 12.0"W.C. High Fire	F92-1008	F0092 100800
	Regulated LP to Natural Gas Conversion Kit for Use On Two Stage 36G, H, J, Valves, Regulation Range 1.0" to 4.0"W.C. Low Fire, 2.0" to 5.0"W.C. High Fire	F92-1011	F0092 101100

Fig. 1: Single stage valve features, terminals and wiring

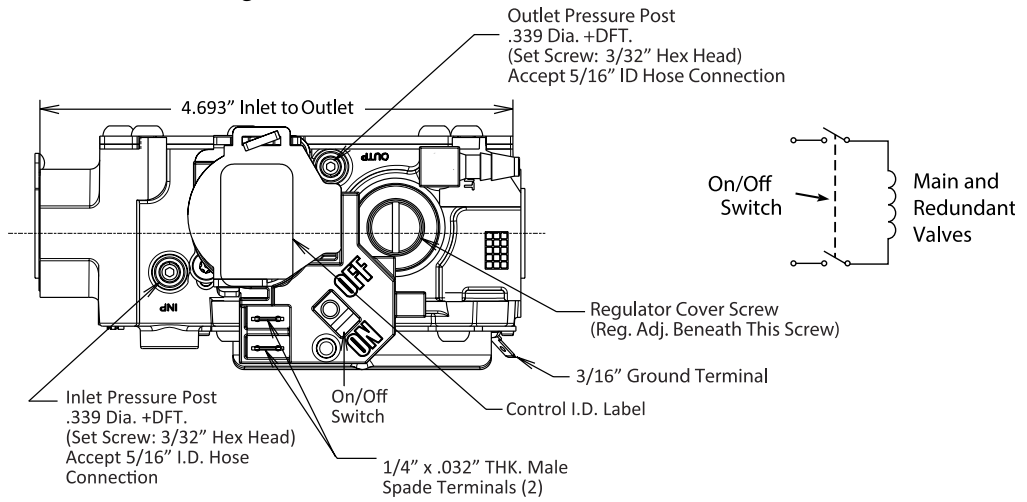


Fig. 2: Two-stage valve features, terminals and wiring

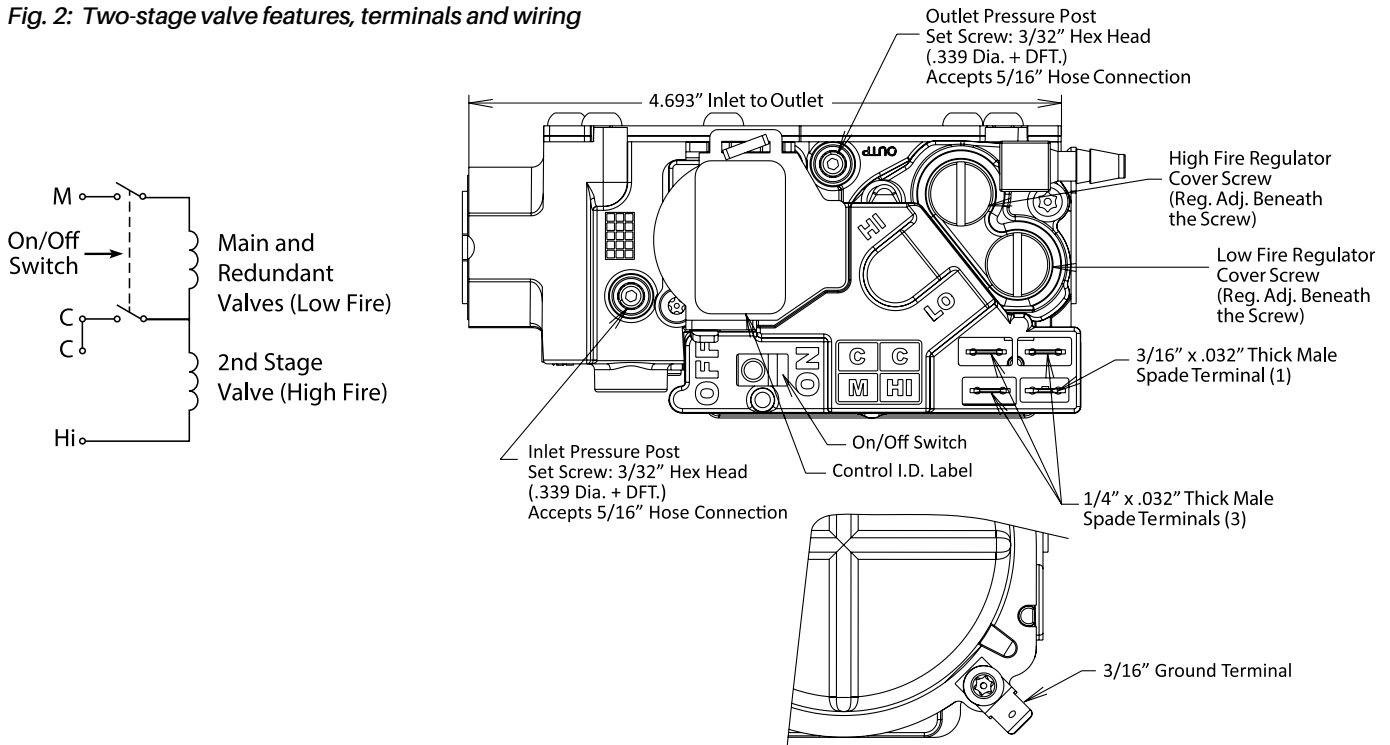
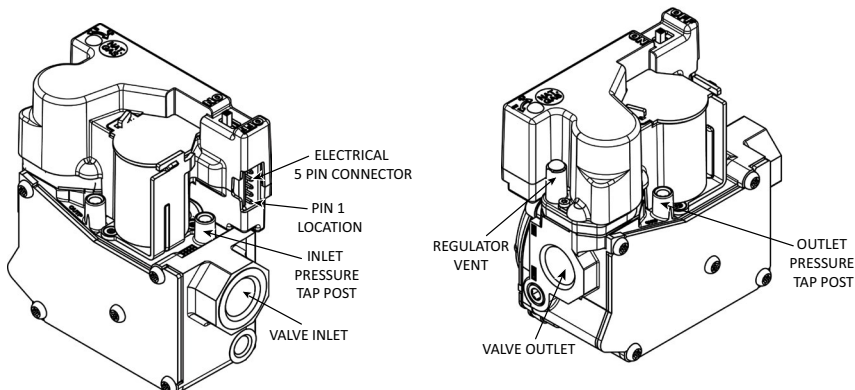


Fig. 3: 36J27 modulating valve features



- Electrical 5 PIN Connector Pin Out
- PIN 5 - TH - Main Valve 24 VAC (top pin, with the cover pointing up)
  - PIN 4 - TR - Ground
  - PIN 3 - TX - Communication to IFC
  - PIN 2 - RX - Communication to Stepper
  - PIN 1 - TH - Board 24VAC (bottom pin, with the cover pointing up)



764-702

# 764 Gas Pilot Safety Fireplace Valves

Thermocouple operated control with 100% shut off

## Features

- Manual on-off knob and thermocouple operated pilot safety
- Inlet screen and inlet pipe stop
- Mounts in any position including upside down

## Specifications

Operating voltage..... 20-30 mV  
 Regulator adjustment range..... Non-regulated  
 Natural gas @ 1.0" P.D. BTU/HR ..... Straight Through 124,000 Bottom Inlet 118,000  
 LP gas @ 1.0" P.D. BTU/HR..... Straight Through 200,880 Bottom Inlet 191,160  
 Inlet connection size ..... 1/2" NPT  
 Outlet connection size ..... Main 1/2" NPT, pilot compression fitting for 1/4" OD tubing  
 Flow direction ..... Dual Inlet Straight Through with Optional Bottom Inlet  
 Maximum pressure rating..... 1/2 PSI (14.0" W.C.)  
 Swing radius..... 2.5"  
 UR/CUR file number..... MP1323  
 CSA/CUS certificate number ..... 1047800

### 764 Gas Pilot Safety, Fireplace Valves

Voltage	Pipe size	Flow direction	1" Pressure drop capacity Natural gas .64 Sp. Gr. (1000 Btu/ft3)	1" Pressure drop capacity LP gas 1.53 Sp. Gr. (2500 Btu/ft3)	Model number	Item number
20 to 30 mV Thermocouple	1/2" X 1/2"	Str. Thru	124,000	200,880	764-501	764-501
20 to 30 mV Thermocouple	1/2" X 1/2"	*Dual Inlet Str. Thru with Optional Bottom Inlet	Side Inlet 124,000, Bottom Inlet 118,000	Side Inlet 200,880, Bottom Inlet 191,160	764-742	07 64 742S1

\* Dual Inlet one inlet must be plugged  
 See White-Rodgers General Information for capacities of other gases

### Parts and accessories

Image	Description	Model number	Item number
	Replacement Knob for 764 Series Valve	F42-0895	F0042 089500S1



25M01A-100

## 25M Gas Dryer Valves & Coils

Clothes dryer gas valves combine pressure regulator main and redundant solenoids for hot surface ignition dryers.

### Features

- Compact split coil design
- Inlet/outlet screen
- Field-adjustable regulator
- Replaceable operating coils (no gas interruption)
- Outlet pressure tap
- Both models packaged with the most popular main burner orifices to replace many OEM models
- Replacement coils available for most popular models
- Single or complete coil sets

### Specifications

Type of gas..... Natural or LP gas (conversion kit included)  
 Pressure regulator setting ..... Nat. Gas: 2.8" to 5.4"W.C., LP Gas: 8.5" to 12.0"W.C.  
 Operating ambient temperature.....32° to 155°F  
 Max. pressure rating ..... 1/2" PSI (14.0" WC)  
 Electrical ..... 120 VAC, 60 Hz, .06 amps  
 1" P.D. capacity..... 40,000 BTU/HR

### 25M Gas Dryer Valves & Coils

Coil voltage	Outlet flow direction	Inlet/outlet size	Regulator adjustment range	Mounting	Model number	Item number
120 VAC	Right Angle Left	3/8" NPT X 11/32"	Nat. Gas: 2.8" to 5.4"W.C. LP Gas: 8.5" to 12.0"W.C. (Conversion Kit Included)	Control may be mounted in the following positions: horizontal, vertical or 90° of horizontal. Do not mount upside down.	25M01A-100	25M01A100
120 VAC	Right Angle Right	3/8" NPT X 11/32"	Nat. Gas: 2.8" to 5.4"W.C. LP Gas: 8.5" to 12.0"W.C. (Conversion Kit Included)	Control may be mounted in the following positions: horizontal, vertical or 90° of horizontal. Do not mount upside down.	25M01A-101	25M01A101



F91-3889



F91-3890

## 2500 Series Replacement Gas Valve Coils

### Features

- Easy installation of replacement coil assemblies
- Available for most popular models
- Single or complete coil sets

### Parts and accessories

Application	Description	OEM	Model number	Item number
25M01A-xxx	120 VAC Coil Replacement for 25M valve individual pack secondary coil	Whirlpool, Electrolux, GE, Maytag, Speed Queen	F91-3889	F0091 388900S1
25M01A-xxx	120 VAC Coil Replacement for 25M valve individual pack booster and holding coil	Whirlpool, Electrolux, GE, Maytag, Speed Queen	F91-3890	F0091 389000S1
25M01A-xxx	Boost/host coil and secondary coil (120 VAC, 60 Hz) for 25M dryer gas valve (includes F91-3889 plus F91-3890 combined)	Whirlpool, Electrolux, GE, Maytag, Speed Queen	F91-4241	F91-4241



21D64-2

# HotRod Series Universal Nitride Ignitor Upgrades

120V nitride upgrade kits for conversion of silicon carbide (flat or spiral).

## Features

- HotRod replaces over 170 ignitors; HotRod EX replaces over 260 ignitor models
- Robust nitride ignitor design for longer life and fewer callbacks – 5-year warranty
- Nitride ignitors with 14.5" and 15.5" lead-stripped ends
- Universal and standard mounting brackets and 2 ceramic wire nuts
- Replaces most silicon carbide ignitors, including many Carborundum models

## Specifications

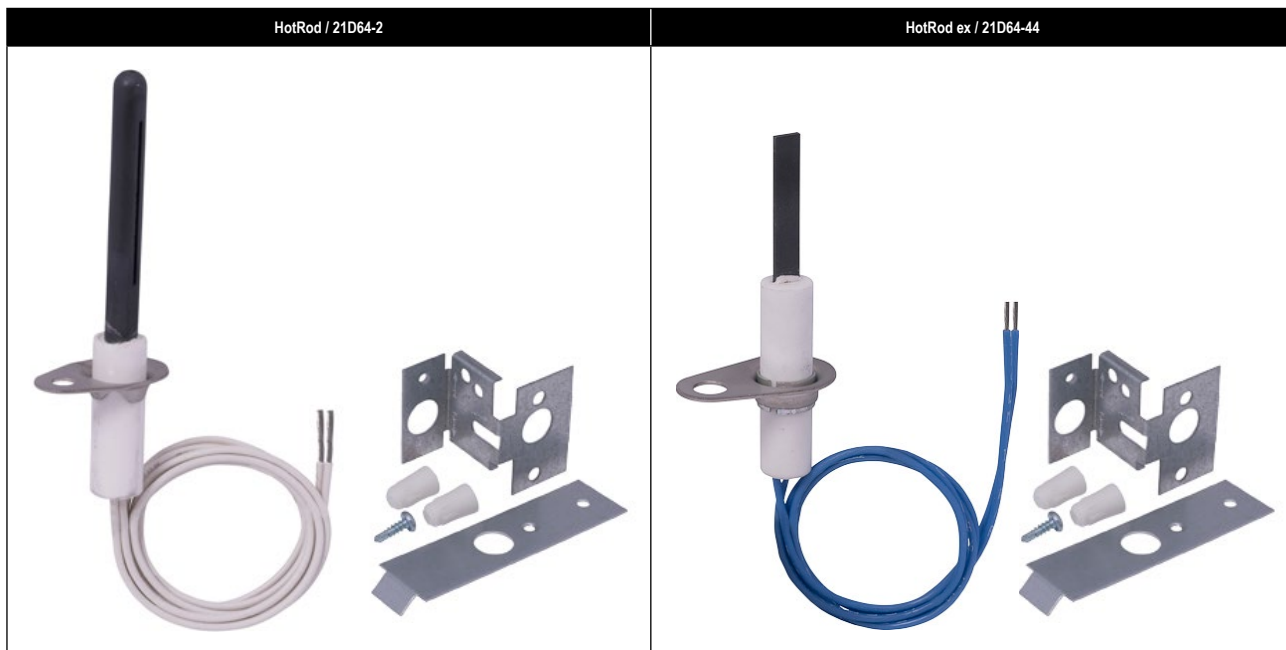
Operating voltage.....	102-132 VAC, 60 Hz
Max. load current .....	3.0 A @ 132 VAC, 25°C
Warmup time.....	21D64-2: 17 sec. minimum
.....	21D64-44: 8 sec. minimum
Temperature rating lead insulation.....	250°C

### HotRod 21D64 Series Universal Ignitor Upgrades

Description	Lead length	Model number	Item number
HotRod Kit includes 120V nitride ignitor, 2 brackets (one universal), 15.5" lead-stripped ends, ceramic wire nuts and mounting screw	15.5"	21D64-2	21D64 002
HotRod 5-pack contains 5 single-pack ignitor kits	15.5"	21D64-5PK	21D64-5PK
HotRod EX Kit includes 120V nitride ignitor, 2 brackets (one universal), 14.5" lead-stripped ends, ceramic wire nuts and mounting screw	14.5"	21D64-44	21D64-44

### Flame sensor and HotRod combo

Description	Lead length	Model number	Item number
HotRod Combo, universal ignitor and flame sensor	15.5" / 30"	21D64C-843	21D64C-843





789A-914A1

# Direct OEM Replacement 80V and 120V Nitride Ignitors

Direct OEM replacement for 80V and 120V premium silicon nitride ignitor and upgrade kits.

## Features

- OEM replacement Nitride Ignitors for Amana, Carrier, Goodman, Lennox, Nordyne, Rheem, Trane, Thermo Products Equipment and York
- 80V and 120V models
- OEM spec lead length, dimensions and connectors for fast replacement
- White high temperature Teflon coated leads
- Insulation 250°C Temperature rating
- Premium Nitride Construction
- 3 Year Warranty

## Specifications






Operating voltage..... 80 and 120 VAC Models, 60 Hz  
 CSA/CUS certificate number ..... 1105159 (768A)  
 ..... 70098928 (789A)

### Direct OEM Replacement 80V and 120V Nitride Ignitors









OEM	Oem model number	Voltage	Lead length (in)	Electrical connections	Model number	Item number
AMANA	1111701	80 VAC	5.00	2 terminal AMP receptacle, .093 female sockets	768A-842	07 68A842S1
	768A-2					
LENNOX, RHEEM	41K5601	80 VAC	12.00	2 terminal AMP receptacle, .084 female sockets	768A-844	07 68A844S1
	768A-4					
THERMO PRODUCTS	380650	80 VAC	5.00	2 terminal AMP receptacle, .084 female sockets	768A-843	07 68A843S1
TRANE	A341947P01	80 VAC	5.00	2 terminal AMP receptacle, .083 female sockets	768A-815	768A-815
	768A-015					
	A341990P01					
	IGN00117	80 VAC	5.00	2 terminal AMP receptacle, .084 female sockets	768A-845	07 68A845S1
	768A-5					
	IGN00104					
X13130524010						
CARRIER	LH332G001	120 VAC	9.25	Molex connector	789A-751A1	789A-751A1
	LH332S001 <sup>1</sup>	120 VAC	9.25	Molex connector	789A-751KT1	789A-751KT1
	LH332S001 <sup>2</sup>	120 VAC	9.25	Molex connector	789A-751KT2	789A-751KT2
GOODMAN	0130F008	120 VAC	9.25	Molex connector	789A-707A1	789A-707A1
	0130F008S					
LENNOX	70W16	120 VAC	9.25	Molex connector	789A-801A1	789A-801A1
	10053602					
	LB-112237B					
NORDYNE	1017743S	120 VAC	5.75	Molex connector	789A-914A1	789A-914A1
	921074					
TRANE	IGN00152	120 VAC	5.00	Molex connector	789A-820KT1	789A-820KT1
	IGN00146					
	D156805P01					
YORK	025-45231-000	120 VAC	5.25	Molex connector	789A-956A1	789A-956A1
	s1-254523100					
	s1-025-4523100					
	025-49808-000					
	s1-02549808000					
	s1-025-49808-000					

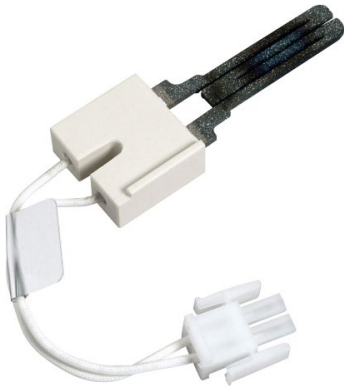
1 For 33 inch tall furnaces. 2 For 40 inch tall furnaces. For complete cross reference information, please download the WRmobile app.

80V models

<p>Trane / 768a-815</p> 	<p>Amana / 768a-842</p> 	<p>Lennox, Rheem / 768a-844</p> 	<p>Thermo products / 768a-843</p> 
<p>Trane / 768a-845</p> 			

120V models

<p>Carrier / 789a-751a1</p> 	<p>Carrier / 789a-751kt1</p> 	<p>Carrier / 789a-751kt2</p> 	<p>Goodman / 789a-707a1</p> 
<p>Lennox / 789a-801a1</p> 	<p>Nordyne / 789a-914a1</p> 	<p>Trane / 789a-820kt1</p> 	<p>York / 789a-956a1</p> 



767A-372

# Direct OEM Replacement 120V Carbide Ignitors

High volume OEM style carbide direct replacements for a wide range of heating equipment.

## Features

- Multiple mounting styles
- Works with 15, 17 or 45 second HSI systems
- All models includes ceramic wire nuts for cut and strip connections
- Extensive cross reference information on our website or download the WR Mobile App


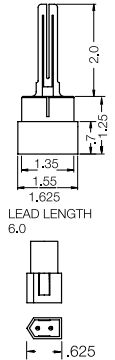

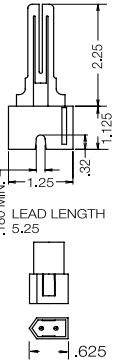

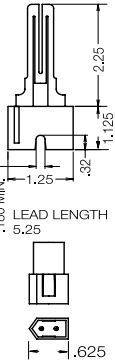
## Specifications


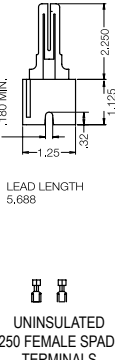

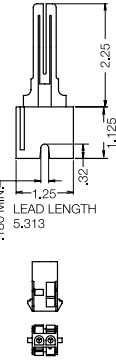

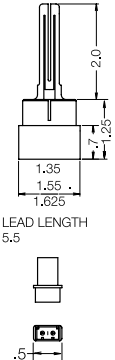
Operating voltage..... 120 VAC, 60 Hz  
 Lead insulation temp. rating ..... 200°C  
 CSA/CUS certificate number ..... 1018175

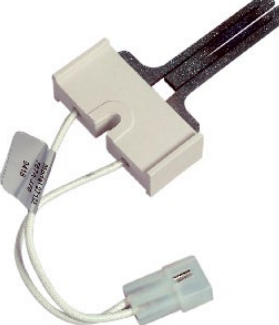
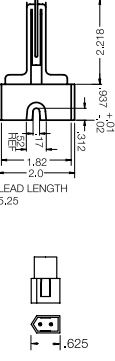

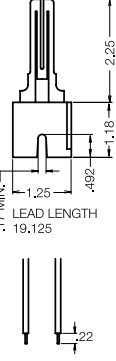
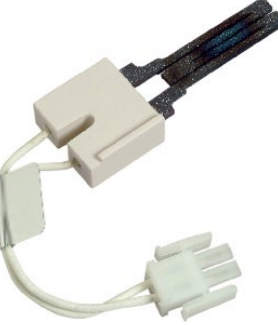
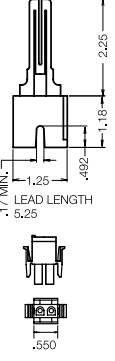
### 767A Series Carbide Direct OEM Replacement Ignitors


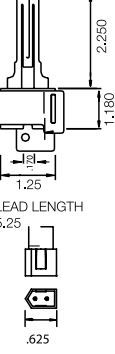



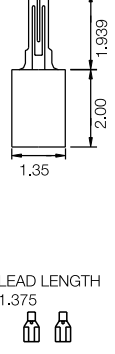
Oem	Voltage	Lead length (in)	Electrical connection	Industry recognized number	Model number	Item number
Amana, Lennox	120 VAC	6.00	Receptacle with .093" Male Pins	41-401	767A-356	07 67A356S1
White-Rodgers	120 VAC	5.25	Receptacle with .093" Male Pins	41-803	767A-357	07 67A357S1
York, Lennox	120 VAC	5.25	Receptacle with .093" Male Pins	41-405	767A-361	07 67A361S1
White-Rodgers	120 VAC	5.69	1/4" Female Spade Terminals	41-803	767A-365	07 67A365S1
White-Rodgers	120 VAC	5.31	AMP 1-480699-0 Electrical Conn. Receptacle with .093" Male Pins	—	767A-366	07 67A366S1
Amana, Lennox	120 VAC	5.50	Molex Internally Keyed Connector with .093" Male Pins	41-401	767A-369	07 67A369
Carrier, Trane, Rheem	120 VAC	5.25	Receptacle with .093" Male Pins	41-409	767A-370	07 67A370
Goodman, York, Nordyne, Trane, Amana, Armstrong	120 VAC	19.13	Stripped Ends	41-402	767A-371	07 67A371
Rheem, Lennox, Trane	120 VAC	5.25	Molex Side Lock Connector with .092" Male Pins	41-408	767A-372	07 67A372
Goodman, York, Nordyne, Trane, Amana, Armstrong	120 VAC	5.25	Receptacle with .093" Male Pins	41-412	767A-373	07 67A373
Whirlpool	120 VAC	11.00	Stripped Ends	41-406	767A-374	07 67A374
White-Rodgers	120 VAC	1.38	1/4" Female Spade Terminals	41-413	767A-375	07 67A375
Trane	120 VAC	4.50	Molex Front Lock Connector with .092" Male Pins	41-407	767A-376	07 67A376
Trane	120 VAC	4.50	Molex Front Lock Connector with .092" Male Pins	41-410	767A-377	07 67A377
Amana	120 VAC	5.13	Electrical Connector matches AMANA #20165702	41-602	767A-378*	07 67A378
York	120 VAC	7.50	Electrical Connector matches YORK #025-33421-000	—	767A-379*	07 67A379
Armstrong	120 VAC	6.13	Electrical Connector matches ARMSTRONG #44744-2	41-604	767A-380*	07 67A380
York	120 VAC	7.50	Electrical Connector matches YORK #473-20937-001	41-605	767A-381*	07 67A381
Weil Mclain	120 VAC	5.25	Receptacle with .093" Male Pins	41-404	767A-382	07 67A382
Rheem	120 VAC	5.25	Molex Side Lock Connector with .092" Male Pins	41-411	767A-383	07 67A383
Goodman	120 VAC	5.25	Receptacle with .093" Male Pins	41-414	767A-384	07 67A384
Goodman	120 VAC	5.25	Receptacle with .093" Male Pins	41-418	767A-385	767A-385


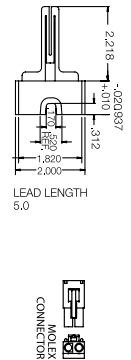

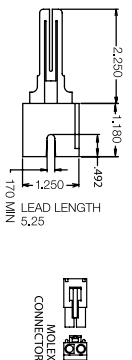

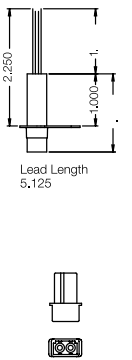
\* Ceramic composite construction  
 For complete cross reference information, please download the WRmobile app.


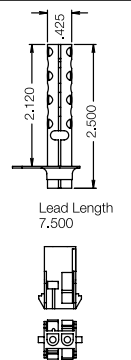

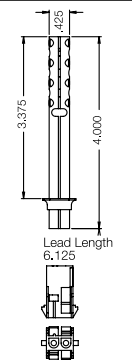

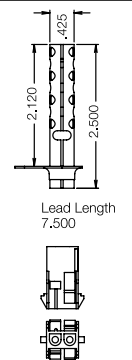
<p><b>767A-356</b></p> 	 <p>LEAD LENGTH 6.0</p> <p>.625</p>	<p><b>767A-357</b></p> 	 <p>LEAD LENGTH 5.25</p> <p>.625</p>	<p><b>767A-361</b></p> 	 <p>LEAD LENGTH 5.25</p> <p>.625</p>
--	--	--	---	--	---


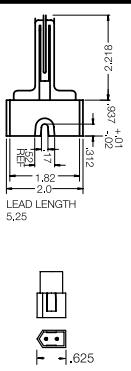

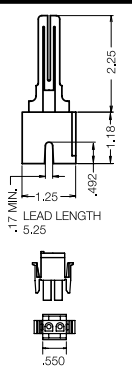

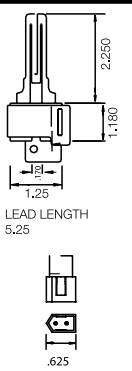
<p><b>767A-365</b></p> 	 <p>LEAD LENGTH 5.688</p> <p>UNINSULATED 250 FEMALE SPADE TERMINALS</p>	<p><b>767A-366</b></p> 	 <p>LEAD LENGTH 5.313</p>	<p><b>767A-369</b></p> 	 <p>LEAD LENGTH 5.5</p> <p>.5</p>
---	---	---	---	---	---


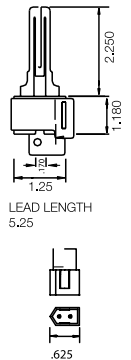
<p><b>767A-370</b></p> 	 <p>LEAD LENGTH 5.25</p> <p>.625</p>	<p><b>767A-371</b></p> 	 <p>LEAD LENGTH 19.125</p> <p>.22</p>	<p><b>767A-372</b></p> 	 <p>LEAD LENGTH 5.25</p> <p>.550</p>
--	---	--	--	--	---

<p><b>767A-373</b></p> 	 <p>LEAD LENGTH 5.25</p> <p>.625</p>	<p><b>767A-374</b></p> 	 <p>LEAD LENGTH 11.00</p> <p>.220</p>	<p><b>767A-375</b></p> 	 <p>LEAD LENGTH 1.375</p>
--	---	--	--	--	--

<p><b>767A-376</b></p> 	 <p>LEAD LENGTH 5.0</p> <p>MOLEX CONNECTOR</p>	<p><b>767A-377</b></p> 	 <p>LEAD LENGTH 5.25</p> <p>MOLEX CONNECTOR</p>	<p><b>767A-378</b></p> 	 <p>Lead Length 5.125</p>
--	---	--	--	--	--

<p><b>767A-379</b></p> 	 <p>Lead Length 7.500</p>	<p><b>767A-380</b></p> 	 <p>Lead Length 6.125</p>	<p><b>767A-381</b></p> 	 <p>Lead Length 7.500</p>
---	---	---	---	---	---

<p><b>767A-382</b></p> 	 <p>LEAD LENGTH 5.25</p> <p>.625</p>	<p><b>767A-383</b></p> 	 <p>LEAD LENGTH 5.25</p> <p>.550</p>	<p><b>767A-384</b></p> 	 <p>LEAD LENGTH 5.25</p> <p>.625</p>
--	---	--	---	--	---

<p><b>767A-385</b></p> 	 <p>LEAD LENGTH 5.25</p> <p>.625</p>
--	---



**H06E-48**

# H06 Series Universal 30 MV Thermocouples

Specially designed for universal replacement.

## Features

- Stainless steel element construction for long thermocouple life
- Universal adapter fittings included for easy installation of thermocouple in pilot burner
- Available in a variety of 10-packs in desired thermocouple lengths
- Standard thermocouple 1 1/32" double lead thread
- Replaces Honeywell Q34A, Johnson K19, Robertshaw 1980 and White-Rodgers H06E

## Specifications

Nominal voltage range ..... 22 - 30 mV  
 Maximum hot junction temperature..... 1450°F  
 Maximum cold junction temperature ..... 800°F

### H06 Series Universal 30 MV Thermocouples

Description	Model number	Item number
18" Thermocouple	H06E-18	H06E018S1
24" Thermocouple	H06E-24	H06E024S1
30" Thermocouple	H06E-30	H06E030S1
36" Thermocouple	H06E-36	H06E036S1
48" Thermocouple	H06E-48	H06E048S1
36" Thermocouple with ECO cut-off connection	H06F-36	H06F036S1



G01A-332

## 750 MV Thermopile Generators

Provides power for 750 millivolt control systems.

### Features

- For replacement of similar screw-in type generators and E31-12 pilot burners
- G01A-332 has 36 inch armored cable leads with split-spade terminals
- PG9 adapter included with each G01A-332
- 101934F32 / 101934R32 designed for use with PG9

### Specifications

Nominal voltage ..... 750 mV  
 Maximum hot junction temperature..... 1400°F  
 Maximum cold junction temperature ..... 650°F

#### 750 MV Thermopile Generators

Mv output	Length	Fiberglass cable leads	Armored cable leads	Pg9 adapter	Clip included	Connector type	Model number	Item number
750	32	□	—	—	—	R Bushing	101934R32	101934R32S2
750	36	—	□	□	□	F Spade Terminal	G01A-332	G01A332S1
750	36	—	□	—	□	F Spade Terminal	G01A-502	G01A502S1
750	36	□	—	□	□	F Spade Terminal	G01A-512	G01A512S1
750	36	—	□	□	□	F Spade Terminal	G01A-132	G01A132S1
750	32	□	—	—	—	F Spade Terminal	101934F32	101934F32S2
750	36	□	—	—	—	F Spade Terminal	G01A-501	G01A501S1

✦ Indicates Canadian Model Number. Call 1-800-305-6953 to order.



PG9A27JTL22

## PG9 Series 750 MV Generators & Pilot Burners

Provides a pilot flame for igniting gas burners while generating millivolt output to operate gas valves and relays.

### Features

- Single blue flame burner for quiet operation and maximum flame stability
- "Snorkel" primary air path incinerates dust eliminating linting problems
- All models provided with orifice base fittings for Natural and LP
- Flame ring surrounding generator ensures high output and extended generator life
- High temperature stainless steel generator cover

#### PG9 Series 750 MV Generators & Pilot Burners

Head type	Porting	Orifice	Fitting	Model number	Item number
Channel Type	90° right & 90° left, 3/4" head width	0.022	Includes extra base fitting for LP gas application (less ferrule and nut)	PG9A27JTL22	PG9A27JTL22S2
Cobra	90° left	0.020	Includes extra base fitting for LP gas application (less ferrule and nut)	PG9A41JTL20	PG9A41JTL20S2
Cobra	90° right	0.020	Includes extra base fitting for LP gas application (less ferrule and nut)	PG9A42JTL20	PG9A42JTL20S2



790-843A1

# 790 Series Universal Flame Sensor

Universal flame sensor for furnaces, or water heaters that use hot surface or spark ignition.

### Features:

- Rod can be bent or cut to replace over 120 part numbers
- High temperature rod withstands 2200°F
- Protective sleeve included for bending the rod with detailed instructions
- 3-year limited warranty
- 30" lead wire with 1/4" quick-connect terminals & 3/16" quick connect terminal included
- Available in a 5-pack box

### Specifications:

Insulation resistance from rod to bracket ..... Must be 500 megaohms at minimum  
 Ceramic material ..... Alumina 95% or better  
 Bracket material ..... Zinc-plated steel or stainless steel  
 Agency ..... CSA

### 790 Series Universal Flame Sensor

Description	Lead length	Electrical connection	Model number	Item number
Universal premium flame sensor	30"	1/4" female spade quick terminal	790-843A1	790-843A1
Universal premium flame sensor, 5-pack	30"	1/4" female spade quick terminal	790-843A5PK	790-843A5PK
HotRod Combo, universal ignitor and flame sensor	15.5" / 30"	1/4" female spade quick terminal	21D64C-843	21D64C-843



790-751A1

# 790 Series Direct OEM Flame Sensors

Drop-in direct OEM replacement flame sensors for Carrier, Goodman, Lennox, Trane and York brands.

### Features:

- Drop-in replacements for OEM brands
- High-temperature rod withstands 2200°F
- OEM-approved construction and material
- 3-year limited warranty

Carrier / ICP 790-751a1 / 73° bend	Goodman 790-707a1 / straight rod	Lennox 790-801a1 / 90° bend	Trane 790-820a1 / 90° bend	York 790-956a1 / straight rod



760-401

# Flame Sensors & Electrodes

Hot Surface Ignition and Cycle Pilot Flame Sensors and Electrodes.

## Features

- Cycle Pilot Mercury Flame Sensors designed for 36C84 and 36C94 gas valves include adapters for competitive burners
- 30A46 styles designed for Cushioned Power and Silent Knight gas valves with plug-in receptacles
- 760-401 Universal Hot Surface Ignition Flame Sensors can be mounted remotely on multiple burners

## Specifications

CSA/CUS certificate number ..... 1185540 (760 Series)

### 760 Series for hot surface (HSI) and cycle pilot ignition

Description	Lead length	Electrical connection	Model number	Item number
Cycle Pilot Ignition Electrode and cable assembly with slip on bracket. Also includes perforated mounting strap for varying applications	24"	1/4" female spade quick disconnect terminal	760-56	07 60 56S1
Standard replacement for Hot Surface (HSI) Ignition. Can be mounted remotely on multiple burners	30"	1/4" female spade terminal	760-401	07 60 401S1
Exact OEM model replacement for Hot Surface (HSI) Ignition. Can be mounted remotely on multiple burners	30"	1/4" female spade terminal	760-802	07 60 802S1

### Cycle pilot mercury flame sensors

Description	Element length	Panel type	Bulb style	Model number	Item number
Replaces bulb styles #17 or #18	48"	D	#20	3049-115 ①	30 49 115S1
Replaces bulb styles #9 or #13	48"	E	#19	3098-134 ①	30 98 134S1
Replaces bulb styles #17 or #18	48"	E	#20	3098-156 ①	30 98 156S1

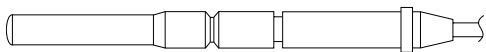
① Includes adapter fittings.

### Mercury flame sensors

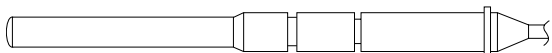
Description	Element length	Electrical rating 120 vac	Electrical rating 240 vac	Electrical rating 30 vac	Model number	Item number
Mercury Flame Sensor with Screw Terminals	48"	125 VA	125 VA	90 VA	3046-5	30 46 005S1
*Plug-In Flame Sensor Stud mount element	48"	125 VA	125 VA	90 VA	30A46-5	30A46 005S1
*Plug-In Flame Sensor Sleeve mount element (no stud mount)	12"	125 VA	125 VA	90 VA	30A46-105	30A46 105S1

\* Plug-In sensors for "Cushioned Power" and "Silent Knight" Gas Valves with Plug-In Receptacle.

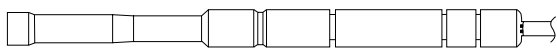
### Flame sensor bulb diagrams



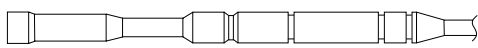
Bulb Style #9



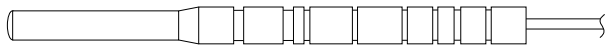
Bulb Style #13



Bulb Style #17



Bulb Style #18



Bulb Style #19

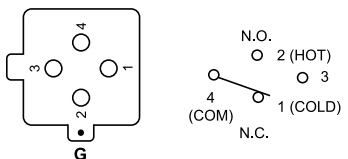
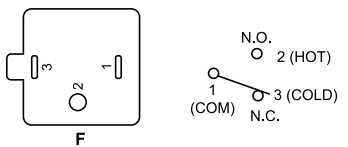
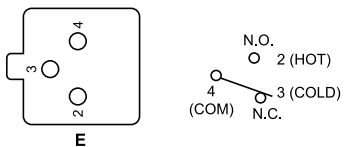
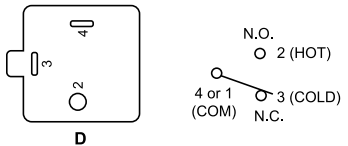
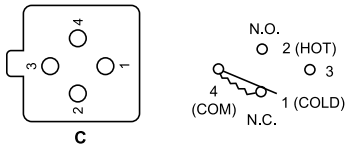
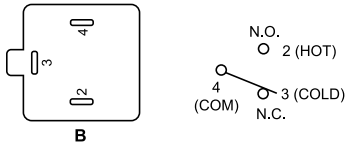
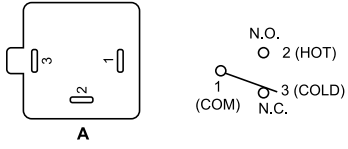


Bulb Style #20

**Contractor tip:**

Mercury flame sensors can only be replaced by cross referencing the original mercury flame sensor model number. They can not be replaced by gas valve model number.

**Terminal panels configuration**



**Types with spade terminals cross reference**

O.E.M. Number	Original capillary length	Original panel types ①	Suggested replacement
3049-52	30"	B, D	3049-115
3049-54	30"	B	3049-115
3049-55	30"	A, D	3049-115
3049-66	30"	B	3049-115
3049-68	30"	B	3049-115
3049-105	42"	B	3049-115
3049-106	24"	D	3049-115
3049-107	12"	B, D	3049-115
3049-111	24"	B, D	3049-115
3049-112	18"	B, D	3049-115
3049-114	30"	D	3049-115
3049-115	48"	D	3049-115
3049-119	24"	B	3049-115
3049-120	30"	B	3049-115
3049-121	18 or 42"	B	3049-115

**Plug-in types cross reference**

O.E.M. Number	Original capillary length	Original panel types ①	Suggested replacement
3098-111	30"	E	3098-134
3098-122	30"	E	3098-156
3098-126	30"	E	3098-156
3098-127	24"	E	3098-156
3098-130	24"	E	3098-156
3098-131	30"	E	3098-156
3098-134	48"	E	3098-134
3098-136	30"	E	3098-134
3098-141	48"	E	3098-134
3098-142	30"	E	3098-156
3098-143	36"	E	3098-156
3098-147	18"	E	3098-134
3098-149	24 or 42"	E	3098-156
3098-153	24"	E	3098-156
3098-156	48"	E	3098-156
3098-161	24 or 30"	E	3098-134
3098-165	48"	E	3098-134
3098-168	48"	E	3098-156
3098-169	27"	E	3098-134
3098-171	30 or 42"	E	3098-156
3094-174	36"	E	3098-156
3098-175	18"	E	3098-156
3098-182	24 or 42"	E	3098-156
3098-184	42"	E	3098-134

① Suggested replacement type may have different panel configuration. Some controls experienced modification. Determine proper wiring with the aid of panel diagrams A through G.



**791P-751KT1**

# Direct OEM Replacement Premium Pilot Burner Assembly

Direct OEM replacement 3-wire pilot burner assembly with safety switch for Carrier /ICP brands.

## Features

- Made by the only qualified source that manufactures for the OEM
- Utilizes a bi-metal switch to protect against oxidation and scaling
- 3-Wire Assembly designed for use with natural and LP gas
- Reliable design with 100% factory performance testing
- Includes factory-installed electrode
- LP orifice included
- 3-Year Limited Warranty

## Specifications

Input voltage .....	18-33 VAC, 60Hz
Input current.....	1.0 Amp
Operating temperature range.....	-40 to 1225 °F (-40 to 662 °C)
Lead wire length.....	9.125"
Lead wire gauge .....	18 AWG
Spark GAP (minimum).....	0.156"
CSA certificate number.....	80080096

### Direct OEM Replacement Premium Pilot Burner Assembly

OEM	OEM model number	Description	Gas type	Input rating	Orifice size	Regulator setting	Model number	Item number
Carrier, ICP	LH680005	Premium 3-Wire Pilot Burner Assembly with Safety Switch	Natural Gas	875 +/- 10% BTU/hr	0.018"	5.00" WC	791P-751KT1	791P-751KT1
			LP Gas	725 +/- 10% BTU/hr	0.012"	11.00" WC		



5D51-35

# 5D51 Series Plenum Mount Bimetal Fan & Limit Controls

For applications with narrow space limitations. Regulates fan or blower operation and acts as high limit safety control.

## Features

- Includes summer fan switch for ventilation without changing control settings
- Dial has individual pointers for fan cut-in and cut-out settings
- Removable solid copper jumper between fan and limit switches
- Long terminal screws for wiring - Junctions can be made on terminal block

## Specifications

Dimensions ..... 4.3"H X 2.9"W X 1.6"D  
 UL/CUL file number ..... MP1228  
 CSA certificate number ..... LR6246-224

### 5D51 Series Plenum Mount Bimetal Fan & Limit Control

Description	Switch action	Element length	Range	Differential	Motor rating (full load) 120 vac	Motor rating (full load) 240 vac	Valves and relays 24 vac	Model number	Item number
Fan / Limit	Fan - Close on Rise Limit - Open on Rise	5"	Fan 50 to 265°F (10 to 129°C), Limit 100 to 300°F (38 to 149°C)	Fan Adjustable 15°F minimum Fixed 25°F, Limit Fixed 25°F	Fan-14.0A Limit-10.0A	Fan-7.0A Limit-6.0A	Fan-5.6A Limit-6.0A	5D51-35	05D51 035S1
Fan / Limit	Fan - Close on Rise Limit - Open on Rise	8"	Fan 50 to 265°F (10 to 129°C), Limit 100 to 300°F (38 to 149°C)	Fan Adjustable 15°F minimum Fixed 25°F, Limit Fixed 25°F	Fan-14.0A Limit-10.0A	Fan-7.0A Limit-6.0A	Fan-5.6A Limit-6.0A	5D51-90	05D51 090S1
Fan / Limit	Fan - Close on Rise Limit - Open on Rise	11"	Fan 50 to 265°F (10 to 129°C), Limit 100 to 300°F (38 to 149°C)	Fan Adjustable 15°F minimum Fixed 25°F, Limit Fixed 25°F	Fan-14.0A Limit-10.0A	Fan-7.0A Limit-6.0A	Fan-5.6A Limit-6.0A	5D51-78	05D51 078S1

See White-Rodgers General Information for full electrical ratings.  
 Fan switches are rated HT, limit switches are rated HTV.



3L09-1

# Snap Disc Fixed Temperature Board Mount Limits

1/2" Automatic reset snap disc thermostats with ranges for all your system needs.

## Features

- Proven reliability in a compact, versatile, cost-effective design
- Provides high-speed contact separation

## Specifications

Switch action.....SPST Open on Rise  
 Electrical ratings..... Resistive 15A @ 120 VAC, 13A @ 240 VAC,  
 .....Inductive 5.8 FLA, 34.8LRA @ 120 VAC; 2.9FLA, 13.0 LRA @ 240 VAC  
 Pilot duty..... 125 VAC  
 Dimensions .....37"H X 1.32"W X 1.23"L  
 Weight..... 0.2 oz.  
 UR/CUR file number..... E19279  
 CSA/CUS certificate number..... LR77886/LR109556  
 VDE Lic. .... 118631

### Snap Disc Fixed Temperature Board Mount Limits

Applications	Cut-in	Cut-out	Switch action	Tod type	Tod style	Length (in)	Model number	Item number
Snap Disc Board Mount Limit - Automatic Reset	100°F (38°C)	140°F (60°C)	Open on Rise	36T01B2	612700	1.87	3L09-1	03L09 001S1
	130°F (54°C)	170°F (77°C)	Open on Rise	36T01B2	612708	1.87	3L09-2	03L09 002S1
	110°F (43°C)	140°F (60°C)	Open on Rise	36T01B3	612701	3.12	3L09-3	03L09 003S1
	130°F (54°C)	150°F (66°C)	Open on Rise	36T01B3	612703	3.12	3L09-4	03L09 004S1
	140°F (60°C)	160°F (71°C)	Open on Rise	36T01B3	612706	3.12	3L09-5	03L09 005S1
	130°F (54°C)	170°F (77°C)	Open on Rise	36T01B3	612710	3.12	3L09-6	03L09 006S1
	145°F (63°C)	175°F (79°C)	Open on Rise	36T01B3	612711	3.12	3L09-7	03L09 007S1
	140°F (60°C)	180°F (82°C)	Open on Rise	36T01B3	612714	3.12	3L09-8	03L09 008S1
	170°F (77°C)	190°F (88°C)	Open on Rise	36T01B3	612715	3.12	3L09-9	03L09 009S1
	160°F (71°C)	200°F (93°C)	Open on Rise	36T01B3	612718	3.12	3L09-10	03L09 010S1
	170°F (77°C)	210°F (99°C)	Open on Rise	36T01B3	612719	3.12	3L09-11	03L09 011S1
	180°F (82°C)	220°F (104°C)	Open on Rise	36T01B3	612722	3.12	3L09-12	03L09 012S1
	210°F (99°C)	240°F (116°C)	Open on Rise	36T01B3	612723	3.12	3L09-13	03L09 013S1
	210°F (99°C)	250°F (121°C)	Open on Rise	36T01B3	612725	3.12	3L09-14	03L09 014S1
	230°F (110°C)	260°F (127°C)	Open on Rise	36T01B3	612727	3.12	3L09-15	03L09 015S1
	130°F (54°C)	150°F (66°C)	Open on Rise	36T01B3	612704	3.12	3L09-16	03L09 016S1
	225°F (107°C)	250°F (121°C)	Open on Rise	36T01B3	612726	3.12	3L09-17	03L09 017S1
	125°F (62°C)	155°F (68°C)	Open on Rise	36T01B3	612705	7.12	3L09-18	03L09 018S1
	145°F (63°C)	175°F (79°C)	Open on Rise	36T01B3	612712	7.12	3L09-19	03L09 019S1
	210°F (99°C)	240°F (116°C)	Open on Rise	36T01B3	612724	7.12	3L09-20	03L09 020S1
	140°F (60°C)	160°F (71°C)	Open on Rise	36T01B3	612707	3.12	3L09-22	03L09 022S1
	150°F (66°C)	170°F (77°C)	Open on Rise	36T01B3	612709	3.12	3L09-23	03L09 023S1
	170°F (77°C)	190°F (88°C)	Open on Rise	36T01B3	612716	3.12	3L09-24	03L09 024S1
	180°F (82°C)	200°F (93°C)	Open on Rise	36T01B3	612717	3.12	3L09-25	03L09 025S1
	160°F (71°C)	180°F (82°C)	Open on Rise	36T01B3	612713	1.87	3L09-26	03L09 026S1
	200°F (93°C)	220°F (104°C)	Open on Rise	36T01B3	612721	1.87	3L09-27	03L09 027S1
	180°F (82°C)	210°F (99°C)	Open on Rise	36T01B3	612720	3.12	3L09-28	03L09 028S1

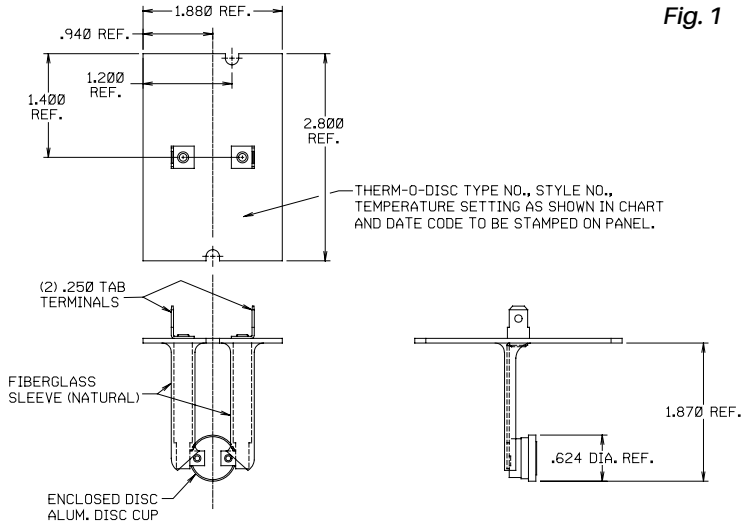


Fig. 1

Model number	Temp. Setting on panel	Open temp.	Close temp.
3L09-1	L140-40	140°F±5°	100°F±8°
3L09-2	L170-40	170°F±5°	130°F±8°

Construction "A"

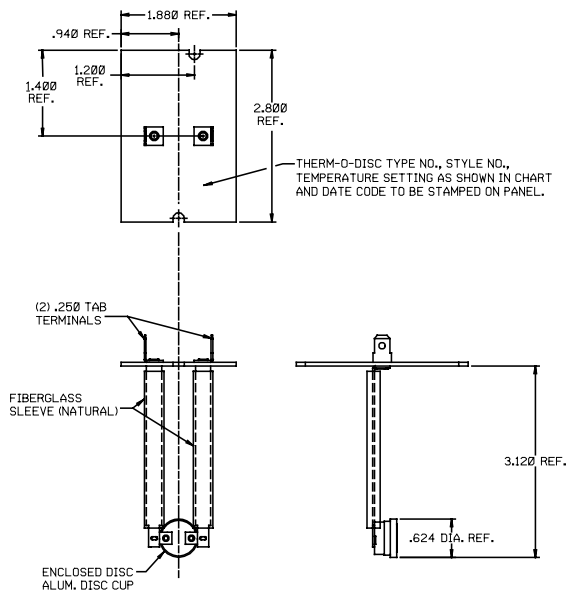
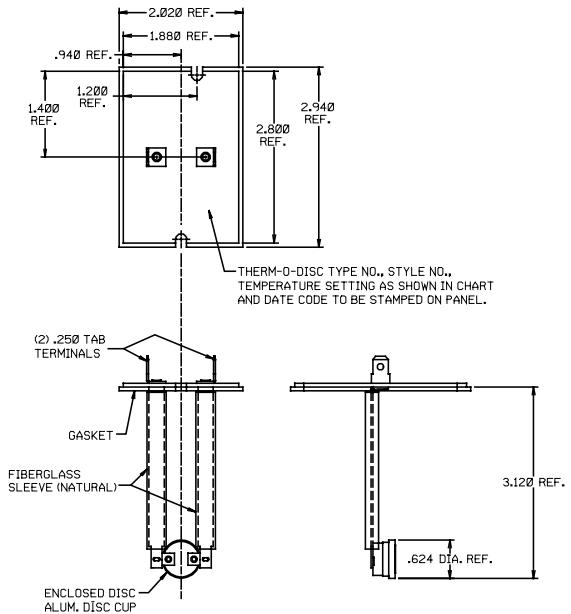
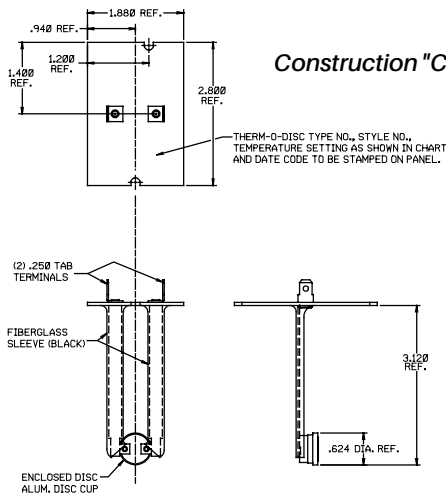


Fig. 2

Construction "B"



Construction "C"



Model number	Construction	Temp. setting on panel	Open temp.	Close temp.
3L09-3	A	L140-30F	140°F±5°	110°F±8°
3L09-4	C	L150-20F	150°F±5°	130°F±8°
3L09-5	C	L160-20F	160°F±5°	140°F±8°
3L09-6	B	L170-40F	170°F±5°	130°F±8°
3L09-7	A	L175-30F	175°F±5°	145°F±8°
3L09-8	B	L180-40F	180°F±6°	140°F±9°
3L09-9	C	L190-20F	190°F±5°	170°F±8°
3L09-10	B	L200-40F	200°F±6°	160°F±9°
3L09-11	B	L210-40F	210°F±6°	170°F±9°
3L09-12	B	L220-40F	220°F±6°	180°F±9°
3L09-13	A	L240-30F	240°F±6°	210°F±10°
3L09-14	B	L250-40F	250°F±7°	210°F±11°
3L09-15	A	L260-30F	260°F±6°	230°F±10°

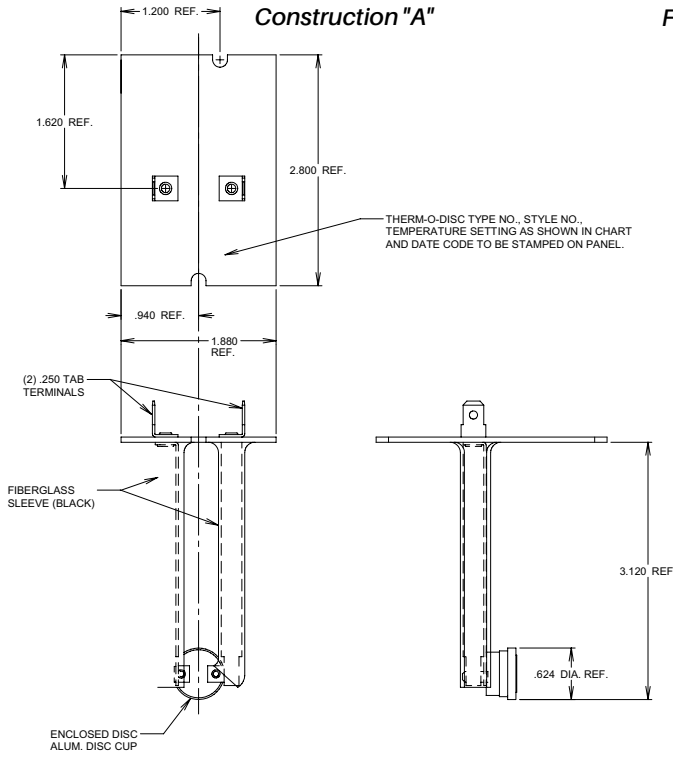
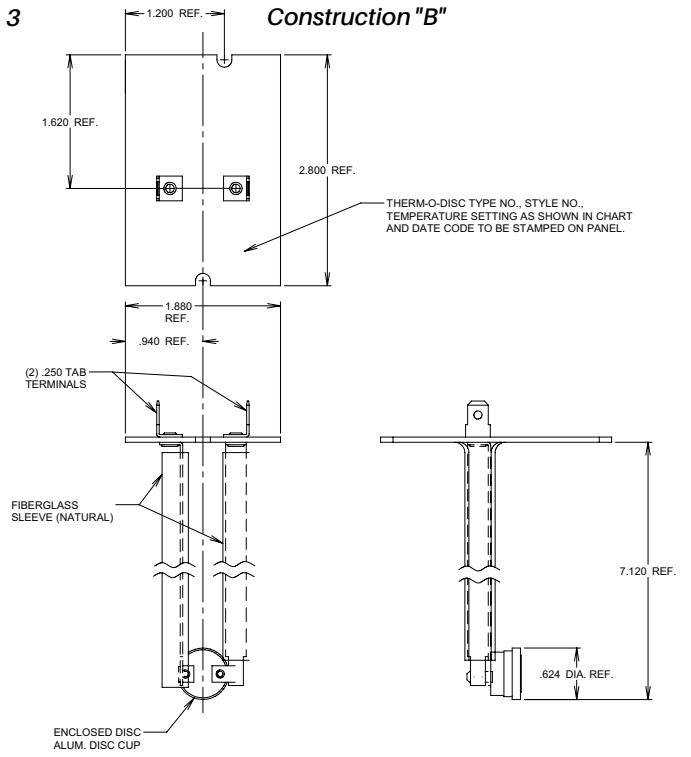


Fig. 3



Model number	Construction	Temp. Setting on panel	Open temp.	Close temp.
3L09-16	A	L150-20F	150°F±5°	130°F±8°
3L09-17	A	L250-25F	250°F±6°	225°F±9°
3L09-18	B	L155-30F	155°F±5°	125°F±8°
3L09-19	B	L175-30F	175°F±5°	145°F±8°
3L09-20	B	L240-30F	240°F±6°	210°F±10°

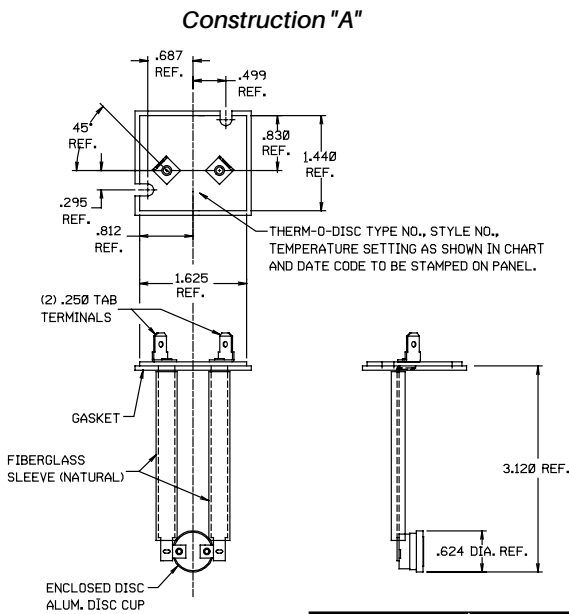
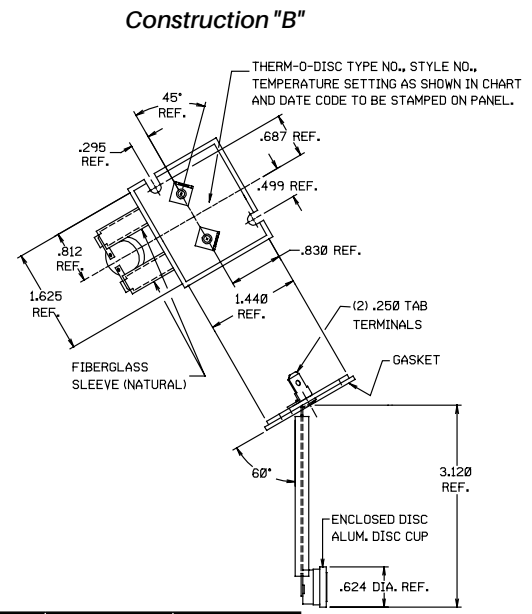
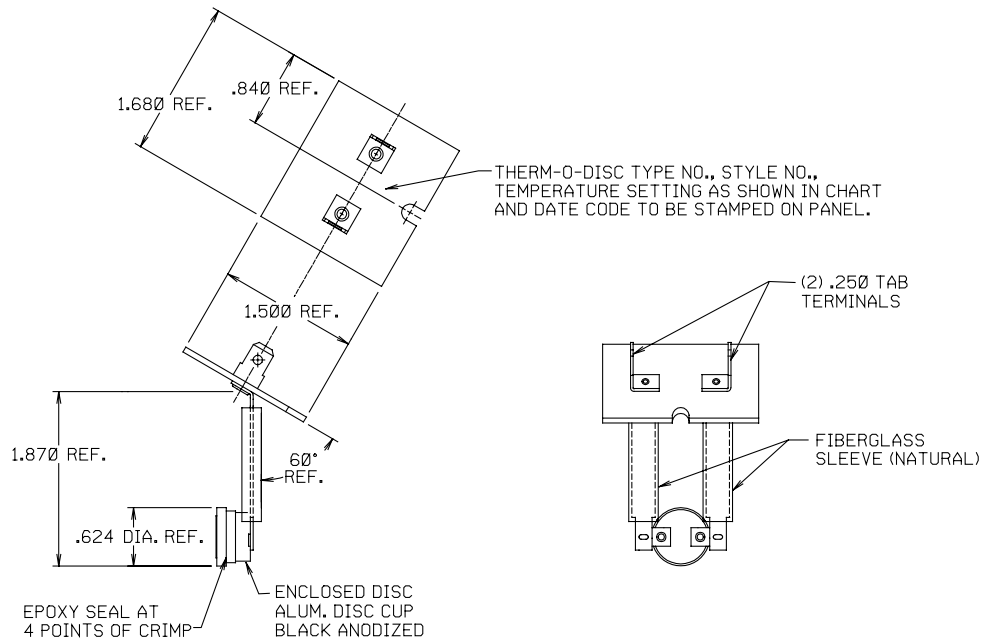


Fig. 4



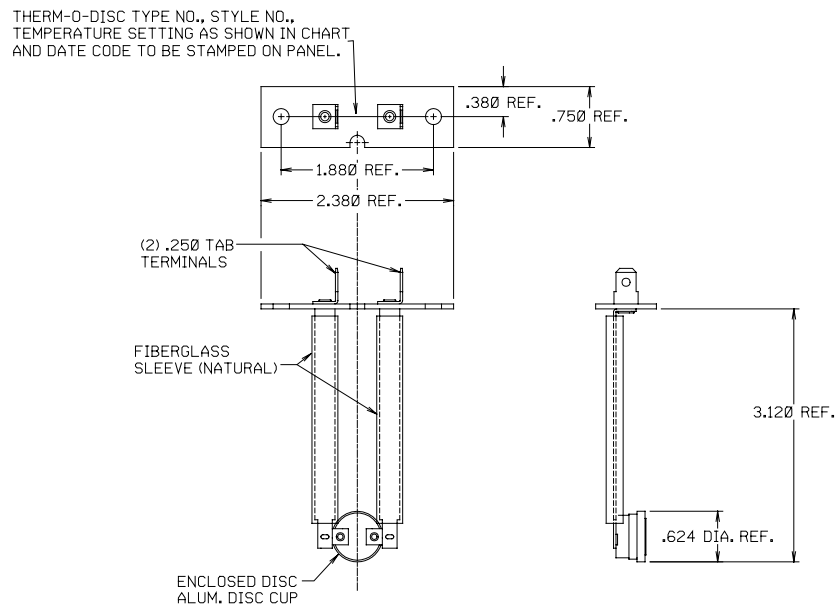
Model number	Construction	Temp. Setting on panel	Open temp.	Close temp.
3L09-22	A	L160-20F	160°F±5°	140°F±8°
3L09-23	A	L170-20F	170°F±5°	150°F±8°
3L09-24	B	L190-20F	190°F±5°	170°F±8°
3L09-25	B	L200-20F	200°F±5°	180°F±8°

Fig. 5



Model number	Temp. Setting on panel	Open temp.	Close temp.
3L09-26	L180-20F	180°F±5°	160°F±8°
3L09-27	L220-20F	220°F±5°	200°F±8°

Fig. 6



Model number	Temp. Setting on panel	Open temp.	Close temp.
3L09-28	L210-30F	210°F±5°	180°F±8°



3L12-130

# Snap Disc Manual Reset Flame Rollout Limits

Manual reset flame rollout limit switches designed for safety in gas fired furnaces, unit heater and roof-top units.

## Features

- Loose ring, stainless steel mounting brackets
- 1/4" quick connect terminals. 90° orientation to mounting hole
- Manual reset
- Stainless steel disc cup

## Specifications

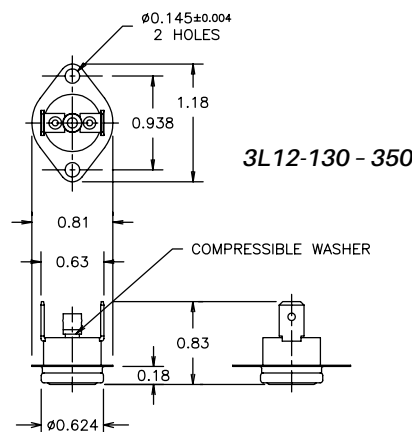
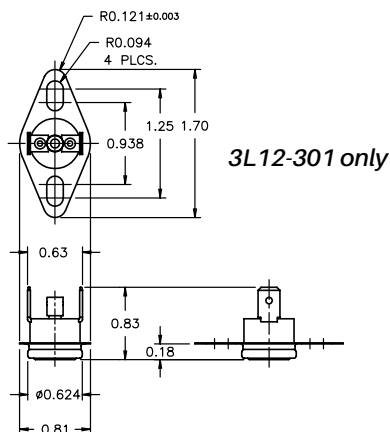
Switch action.....	SPST Open on Rise
Electrical ratings.....	Resistive 15A @ 120 Vac, 10A @ 240 VAC
.....	Inductive 1.5 FLA, 25.0 LRA @ 120 Vac; 1.5 FLA, 6.0LRA @ 240 VAC
Pilot duty.....	125 VA
Dimensions.....	
3L12-301.....	83"H X .81"W X 1.18"L
Others.....	83"H X .81"W X 1.70"L
Weight.....	0.2 oz.
UR/CUR file number.....	E19279
CSA/CUS certificate number.....	LR77886/LR109556
VDE Lic. ....	118631

### Snap Disc Manual Reset Flame Rollout Limits

Application	Fixed temperature settings cut-in	Fixed temperature settings cut-out	Switch action	Therm-o-disc type	Therm-o-disc style	Model number	Item number
Snap Disc Limit - Manual Reset	Manual Reset	130°F (54°C)	Open on Rise	36TX16	611863	3L12-130	3L12-130
	Manual Reset	135°F (57°C)	Open on Rise	36TX16	611864	3L12-135	3L12-135
	Manual Reset	220°F (104°C)	Open on Rise	36TX16	611865	3L12-220	3L12-220
	Manual Reset	230°F (110°C)	Open on Rise	36TX16	611866	3L12-230	3L12-230
	Manual Reset	240°F (116°C)	Open on Rise	36TX16	611867	3L12-240	3L12-240
	Manual Reset	250°F (121°C)	Open on Rise	36TX16	611868	3L12-250	3L12-250
	Manual Reset	260°F (127°C)	Open on Rise	36TX16	611869	3L12-260	3L12-260
	Manual Reset	300°F (149°C)	Open on Rise	36TX16	611870	3L12-300	3L12-300
	Manual Reset	350°F (177°C)	Open on Rise	36TX16	611871	3L12-350	3L12-350
	Manual Reset	300°F (149°C)	Open on Rise	36TX16	611971	3L12-301*	3L12-301*

\* Specifically designed for ICP part #1013102

### 3L12 series outline diagrams





3F01-130

# Snap Disc Fixed Temperature Fan Limits

Automatic reset, manual reset and SPDT styles for fans, blowers or high limit cut out.

## Features

- Loose ring, stainless steel mounting brackets
- Mounting holes match standard 3/4" snap discs
- 1/4" quick connect terminals
- Last three numbers indicate cut-in temperatures on fan controls and cut-out temperatures on limits

## Specifications

Maximum ambient .....350°F  
 Switch action..... SPST Open or Close on Rise  
 Electrical ratings..... Resistive 25A @ 120 VAC, 25A @ 240 VAC  
 ..... Inductive 10 FLA, 60 LRA @ 120 VAC; .5 FLA, 30 LRA @ 240 VAC  
 3L03: terminals 1 & 2 close on rise..... Resistive 25A @ 120 VAC, 25A @ 240 VAC  
 .....Inductive 5.8 FLA, 34.8 LRA @ 120 VAC; 2.9 FLA, 17.4 LRA @ 240 VAC  
 3L03: terminals 1 & 3 open on rise..... Resistive 25A @ 120 VAC, 25A @ 240 VAC  
 ..... Inductive 10 FLA, 60 LRA @ 120 VAC; .5 FLA, 30 LRA @ 240 VAC  
 Pilot duty..... 125 VA  
 Dimensions .....37"H X 1.32"W X 1.23"L  
 Weight..... 0.2 oz.  
 UR/CUR file number..... E 19279  
 CSA/CUS certificate number..... LR77886/LR109556  
 VDE Lic. .... 118631

### Snap Disc Fixed Temperature Fan Limits

Application	Fixed temperature settings cut-in	Fixed temperature settings cut-out	Switch action	Therm-o-disc type	Therm-o-disc style	Model number	Item number
Snap Disc Fan - Automatic Reset SPST	110°F (43°C)	90°F (32°C)	Close on Rise	60T12	610044	3F01-110	03F01 110S1
	120°F (49°C)	110°F (43°C)	Close on Rise	60T12	610046	3F01-120	03F01 120S1
	130°F (54°C)	115°F (46°C)	Close on Rise	60T12	610047	3F01-130	03F01 130S1
	140°F (60°C)	120°F (49°C)	Close on Rise	60T12	611866	3F01-140	03F01 140S1
	150°F (66°C)	130°F (54°C)	Close on Rise	60T12	610050	3F01-150	03F01 150S1
	160°F (71°C)	140°F (60°C)	Close on Rise	60T12	610064	3F01-160	03F01 160S1
	180°F (82°C)	160°F (71°C)	Close on Rise	60T12	610065	3F01-180	03F01 180S1
	200°F (93°C)	180°F (82°C)	Close on Rise	60T12	610066	3F01-200	03F01 200S1
	350°F (177°C)	320°F (160°C)	Close on Rise	60T12	610067	3F01-350	03F01 350S1
Snap Disc Limit - Automatic Reset SPST	110°F (43°C)	120°F (49°C)	Open on Rise	60T11	610000	3L01-120	03L01 120S1
	115°F (46°C)	130°F (54°C)	Open on Rise	60T11	610002	3L01-130*	03L01 130S1
	100°F (38°C)	140°F (60°C)	Open on Rise	60T11	610006	3L01-140	03L01 140S1
	110°F (43°C)	150°F (66°C)	Open on Rise	60T11	610009	3L01-150	03L01 150S1
	125°F (52°C)	165°F (74°C)	Open on Rise	60T11	610069	3L01-165	03L01 165S1
	130°F (54°C)	170°F (77°C)	Open on Rise	60T11	610012	3L01-170	03L01 170S1
	140°F (60°C)	180°F (82°C)	Open on Rise	60T11	610013	3L01-180	03L01 180S1
	150°F (66°C)	190°F (88°C)	Open on Rise	60T11	610015	3L01-190	03L01 190S1
	160°F (71°C)	200°F (93°C)	Open on Rise	60T11	610016	3L01-200	03L01 200S1
	190°F (88°C)	230°F (110°C)	Open on Rise	60T11	610021	3L01-230	03L01 230S1
	210°F (99°C)	250°F (121°C)	Open on Rise	60T11	610023	3L01-250**	03L01 250S1
	250°F (121°C)	300°F (149°C)	Open on Rise	60T11	610026	3L01-300*	03L01 300S1
	310°F (154°C)	350°F (177°C)	Open on Rise	60T11	610068	3L01-350	03L01 350S1

Snap disc fixed temperature fan limits (continued)

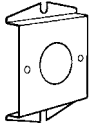
Application	Fixed temperature settings cut-in	Fixed temperature settings cut-out	Switch action	Therm-o-disc type	Therm-o-disc style	Model number	Item number
Snap Disc Limit - Manual Reset SPST	Manual Reset	160°F (71°C)	Open on Rise	60T15	330534	3L02-160	03L02 160S1
	Manual Reset	170°F (77°C)	Open on Rise	60T15	330535	3L02-170	03L02 170S1
	Manual Reset	180°F (82°C)	Open on Rise	60T15	330536	3L02-180	03L02 180S1
	Manual Reset	190°F (88°C)	Open on Rise	60T15	330537	3L02-190	03L02 190S1
	Manual Reset	200°F (93°C)	Open on Rise	60T15	330538	3L02-200	03L02 200S1

\* 3L01-130 and -300 terminals at 30° angle  
 \*\* 3L01-250 terminals is perpendicular to bracket

Snap disc fixed temperature fan limits

Application	Terminal 1 & 3 cut-in (closes on fall) at:	Terminal 1 & 3 cut-out (opens on rise) at:	Terminal 1 & 2 cut-in (closes on rise) at:	Terminal 1 & 2 cut-out (open on fall) at:	Switch action	Therm-o-disc type	Therm-o-disc style	Model number	Item number
Snap Disc Fan or Limit - Automatic Reset SPDT	120°F (49°C)	140°F (60°C)	140°F (60°C)	120°F (49°C)	SPDT	60T13	611015	3L03-140	03L03 140S1
	170°F (77°C)	190°F (88°C)	190°F (88°C)	170°F (77°C)	SPDT	60T13	611014	3L03-190	03L03 190S1

Parts and accessories

Image	Description	Model number	Item number
	Fan and limit mounting adapter for 3F01 / 3L01 / 3L02 / 3F02 / 3L03 / 3F05 / 3L05 series controls.	F6-1798	F0006 179800S1



3L05-2

# Snap Disc Adjustable Temperature Fan Limits

3/4" adjustable automatic reset snap disc thermostats allows you to set the temperature set point to match your specific needs.

## Features

- 1/4" quick connect terminals are standard
- Reduces inventory while providing coverage for a wide range of temperature applications
- Replaces the majority of fixed disc thermostats now on heating equipment and various appliances
- 2 adjustable fan control models replace 7 fixed snap disc models
- 5 adjustable limit control models replace 10 fixed snap disc models

## Specifications

Switch action..... SPST Open or Close on Rise  
 Electrical ratings..... Resistive 25A @ 120 VAC, 25A @ 240 VAC,  
 ..... Inductive 14 FLA, 72 LRA @ 120 VAC; 10 FLA, 60 LRA @ 240 VAC Pilot duty 125  
 VA  
 Dimensions..... 37"H X 1.32"W X 1.23"L  
 Weight..... 0.2 oz.  
 UR/CUR file number..... E19279  
 CSA/CUS certificate number..... LR77886/LR109556  
 VDE Lic. .... 118631

### Snap Disc Fixed Temperature Fan Limits

Application	Temperature setpoint range	Switch action	Differential	Therm-o-disc type	Therm-o-disc style	Model number	Item number
Snap Disc Fan - Adjustable Setting, Automatic Reset	90°F (32°C), to 130°F (54°C)	Close on Rise	20°F (11°C)	74T12	310708	3F05-1	03F05 001S1
	140°F (60°C), to 180°F (82°C)	Close on Rise	20°F (11°C)	74T12	310709	3F05-2	03F05 002S1
	135°F (57°C), to 175°F (79°C)	Open on Rise	40°F (22°C)	74T11	310710	3L05-1	03L05 001S1
	175°F (79°C), to 215°F (102°C)	Open on Rise	40°F (22°C)	74T11	310711	3L05-2	03L05 002S1
	210°F (99°C), to 250°F (121°C)	Open on Rise	40°F (22°C)	74T11	310712	3L05-3	03L05 003S1
	135°F (57°C), to 175°F (79°C)	Open on Rise	20°F (11°C)	74T11	310724	3L05-10	03L05 010S1
	250°F (121°C), to 290°F (143°C)	Open on Rise	40°F (22°C)	74T11	310730	3L05-13	03L05 013S1

### Parts and accessories

Image	Description	Model number	Item number
	Fan and limit mounting adapter for 3F01 / 3L01 / 3L02 / 3F02 / 3L03 / 3F05 / 3L05 series controls.	F6-1798	F006 179800S1



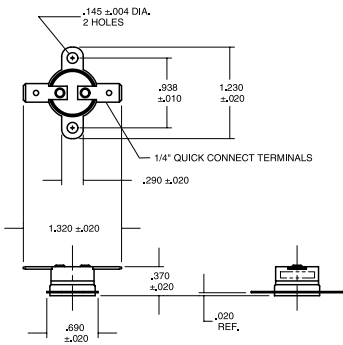
# Snap Disc Automatic Reset Fan Limits

1/2" Automatic reset snap disc thermostats for appliance and HVAC.

## Features

- Loose ring, stainless steel mounting brackets
- 1/4" quick connect terminals
- Aluminum disc cup
- Last three numbers indicate cut-in temperatures on fan controls and cut-out temperatures on limits

3F11-100



## Specifications

Switch action..... SPST Open or Close on Rise  
 Electrical ratings..... Resistive 15A @ 120 VAC, 10A @ 240 VAC,  
 .....Inductive 3.0 FLA, 12.0LRA @ 120 VAC; 1.5FLA, 6.0LRA @ 240 VAC  
 Pilot duty..... 125 VA  
 Dimensions......37\"/>

### Snap disc automatic reset fan limits

Application	Cut-in	Cut-out	Switch action	Differential	Therm-o-disc type	Therm-o-disc style	Model number	Item number
Snap Disc Fan - Automatic Reset	100°F (38°C)	70°F (21°C)	Close on rise	30°F (17°C)	36T22	10844	3F11-100	03F11 100
	120°F (49°C)	90°F (32°C)	Close on rise	30°F (17°C)	36T22	10847	3F11-120	03F11 120
	140°F (60°C)	110°F (43°C)	Close on rise	30°F (17°C)	36T22	10849	3F11-140	03F11 140
	170°F (77°C)	140°F (60°C)	Close on rise	30°F (17°C)	36T22	10853	3F11-170	03F11 170
	180°F (82°C)	150°F (66°C)	Close on rise	30°F (17°C)	36T22	10856	3F11-180	03F11 180
	225°F (107°C)	195°F (91°C)	Close on rise	30°F (17°C)	36T22	10860	3F11-225	03F11 225
	240°F (116°C)	140°F (60°C)	Close on rise	100°F (56°C)	36T22	10862	3F11-240	03F11 240
Snap Disc Limit - Automatic Reset	40°F (4°C)	60°F (16°C)	Open on rise	20°F (12°C)	36T21	10842	3L11-60	03L11 060
	70°F (21°C)	85°F (29°C)	Open on rise	15°F (8°C)	36T21	10843	3L11-85	03L11 085
	110°F (43°C)	80°F (27°C)	Open on rise	30°F (17°C)	36T21	10845	3L11-110	03L11 110
	90°F (32°C)	120°F (49°C)	Open on rise	30°F (17°C)	36T21	10846	3L11-120	03L11 120
	110°F (43°C)	140°F (60°C)	Open on rise	30°F (17°C)	36T21	10848	3L11-140	03L11 140
	120°F (49°C)	150°F (66°C)	Open on rise	30°F (17°C)	36T21	10850	3L11-150	03L11 150
	130°F (54°C)	160°F (71°C)	Open on rise	30°F (17°C)	36T21	10851	3L11-160	03L11 160
	140°F (60°C)	170°F (77°C)	Open on rise	30°F (17°C)	36T21	10852	3L11-170	03L11 170
	160°F (71°C)	175°F (79°C)	Open on rise	15°F (8°C)	36T21	10854	3L11-175	03L11 175
	150°F (66°C)	180°F (82°C)	Open on rise	30°F (17°C)	36T21	10855	3L11-180	03L11 180
	160°F (71°C)	190°F (88°C)	Open on rise	30°F (17°C)	36T21	10857	3L11-190	03L11 190
	180°F (82°C)	210°F (99°C)	Open on rise	30°F (17°C)	36T21	10858	3L11-210	03L11 210
	190°F (88°C)	220°F (104°C)	Open on rise	30°F (17°C)	36T21	10859	3L11-220	03L11 220
	200°F (93°C)	230°F (110°C)	Open on rise	30°F (17°C)	36T21	10861	3L11-230	03L11 230
	220°F (104°C)	250°F (121°C)	Open on rise	30°F (17°C)	36T21	10863	3L11-250	03L11 250
	275°F (135°C)	325°F (163°C)	Open on rise	50°F (28°C)	36T21	10864	3L11-325	03L11 325



230-22

# 230-22 Fan Control

Provides regulation of duct temperatures in conjunction with air handling units or control of circulator for indoor-outdoor regulation from a remote point.

## Features

- Hydraulic action element - Unaffected by vibration
- Switch case mounts in any position - No leveling required. Includes bulb mounting clip
- High electrical rating permits operation of most equipment without use of relays or motor starters
- Dustproof steel case - Dial visible and can be adjusted through cover. Case has knockouts on top and bottom

## Specifications

Dimensions ..... 5.75"H X 2.32"W X 2.56"D  
 Finish ..... Grey  
 UR/CUR file number ..... E12615

### 230-22 Fan Control

Switch action	Range	Differential	Capillary length	Bulb size	Motor rating (full load)		Resistive (non-inductive)		Model number	Item number
					120 Vac	240 Vac	120 Vac	240 Vac		
Open on Rise (Heating)	20 to 120°F (-6 to 49°C)	Adj. 4 to 30°F (2.2 to 17°C)	8 ft.	6-1/4 x 3/8"	14.0A	7.0A	25.0A	22.0A	230-22 ①	02 30 022S1

① U.L. approved adjustable dial stop, factory set at 90°F maximum.  
 See White-Rodgers General Information for full electrical ratings.



775-1

## 775-1 Attic Fan Control

Ideal for replacement of similar type controls.

### Features

- For use where space is limited
- Small bimetal sensing element
- Snap-Action switch
- Fan control has adjustable range with direct reading temperature dial

### Specifications

Dimensions ..... 2.8"H X 3.59"W X 2.02"D

#### 775-1 Attic Fan Control

Description	Range	Differential	Switch action	Motor rating (full load)		Pilot duty	Model number	Item number
				120 Vac	240 Vac			
Attic Fan Control with Thermal Limiter	60 to 120°F ① (15 to 49°C)	Fixed 10°F (6°C)	Close on Rise	9.0 A	—	—	775-1	07 75 001S1

① Thermal limiter opens at 183°F (84°C)



770-1

## 770 Series Dual Purpose Air Switch

Responds to positive, negative or differential air pressure.

### Features

- Design eliminates "fluttering" or malfunction due to shock or vibration normally encountered with "sail switches"
- Furnished with one 12" piece 1/4" O.D. flexible tubing, nuts and ferrules
- Wide operating range
- Can be mounted in any position except upside down
- Enclosed diaphragm

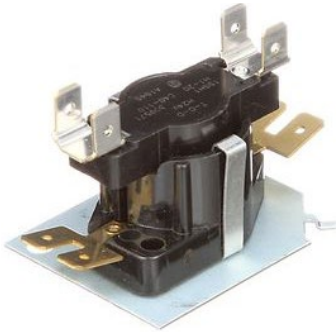
### Specifications

Electrical rating ..... 1/2 HP @ 125 VAC  
 Maximum pressure ..... 1/2 PSI  
 Ambient temperature ..... -40 to + 180°F  
 UL/CUL file number ..... MP204

#### 770 Series Dual Purpose Air Switch

Switch action	Adjustable operating range	Electrical ratings resistive (non-inductive) 120 vac	Electrical ratings resistive (non-inductive) 240 vac	Electrical ratings 125-277 Vac	Model number	Item number
SPDT	0.05 to 12.0 W.C.	15.0A	15.0A	300 VA	770-1	07 70 001S1
SPDT	0.05 to 12.0 W.C.	15.0A	15.0A	300 VA	770-3	07 70 00305

\* Indicates Canadian Model Number: Call 1-800-305-6953 to order.



24A34-3

# 24A34 Series Electric Heat Sequencers

Direct replacement for most fan and heat sequencing functions.

## Specifications

Ambient temperature rating.....-50 to +165°F  
 UR/CUR file number..... E12615

### Electrical ratings - single load contact ratings (all models)

Inductive (motor) full load 120 vac	Inductive (motor) full load 240 vac	Inductive (motor) full load 480 vac	Inductive (motor) locked rotor 120 vac	Inductive (motor) locked rotor 240 vac	Inductive (motor) locked rotor 480 vac	Resistive (non-inductive) 120 vac	Resistive (non-inductive) 240 vac	Resistive (non-inductive) 480 vac	Pilot duty
14.0A	7.0A	—	72.0A	42.0A	—	25.0A, 3000W	25.0A, 6000W	12.5A, 6000W	120-240 VAC 125 VA, 480 VAC 480 VA

### 24A34 Series Electric Heat Sequencers

Timings	Switches	Timings - on					Timings - off					Model number	Item number
		M1-M2	M3-M4	M5-M6	M7-M8	M9-M10	M1-M2	M3-M4	M5-M6	M7-M8	M9-M10		
1	1	1-20	—	—	—	—	40-110	—	—	—	—	24A34-1	24A34 001S1
1	1	—	—	30-90	—	—	—	—	1-30	—	—	24A34-2	24A34 002S1
1	2	1-20	◆ 1-20	—	—	—	40-110	◆ 40-110	—	—	—	24A34-3 ①	24A34 003S1
1	2	—	—	30-90	◆ 30-90	—	—	—	1-30	◆ 1-30	—	24A34-4	24A34 004S1
2	3	1-110	◆ 1-110	1-110	—	—	1-110	◆ 1-110	1-110	—	—	24A34-5 ①	24A34 005S1
2	4	1-110	◆ 1-110	1-110	◆ 1-110	—	1-110	◆ 1-110	1-110	◆ 1-110	—	24A34-6 ①	24A34 006S1
4	5	1-160	◆ 1-160	1-160	1-160	1-160	1-160	◆ 1-160	1-160	1-160	1-160	24A34-14 ① ②	24A34 014S1
1	1	1-20	—	—	—	—	1-50	—	—	—	—	24A34-21	24A34 021B1
1	1	15-45	—	—	—	—	1-30	—	—	—	—	24A34-22	24A34 022B1
1	1	25-55	—	—	—	—	15-45	—	—	—	—	24A34-23	24A34 023B1
1	1	30-75	—	—	—	—	1-40	—	—	—	—	24A34-24	24A34 024B1
1	1	40-90	—	—	—	—	1-30	—	—	—	—	24A34-25	24A34 025B1
2	2	1-20	30-90	—	—	—	40-90	1-30	—	—	—	24A34-26	24A34 026B1
2	2	1-160	1-160	—	—	—	1-160	1-160	—	—	—	24A34-27	24A34 027B1
2	2	1-160	1-160	—	—	—	1-160	1-160	—	—	—	24A34-28 ③	24A34 028B1
1	1	15-35	—	—	—	—	25-55	—	—	—	—	24A34-29	24A34 029B1
2	2	1-20	30-45	—	—	—	45-110	1-30	—	—	—	24A34-36	24A34 036B1
1	1	1-110	—	—	—	—	1-110	—	—	—	—	24A34-37	24A34 037B1

### Combined load rating table (all models):

30A @ 240 VAC – TOTAL,  
 23A Non-Inductive + 7 FLA / 42 LRA Inductive  
 ON Time: Elapsed time to make contacts after heater is energized (min. to max.)  
 OFF Time: Elapsed time to break contacts after heater is de-energized (min. to max.)

### Table notes:

- ① M1-M2 and M3-M4 are always first switches to turn ON and last to turn OFF. All other switches are random ON and random OFF
- ② 24A34-14 Switch contacts designated F<sub>1</sub> - F<sub>2</sub> instead of M<sub>1</sub> - M<sub>2</sub>
- ③ 24A34-28 is 2 pole double throw
- ◆ These contacts switch simultaneously
- ✦ Indicates Canadian Model Number: Call 1-800-305-6953 to order.

**Note:** Underwriters Laboratories requires a fan interlock circuit to insure the blower remains operating whenever more than one sequencer is used. The fan interlock should be the M1 / M2 contacts of the second or third sequencer. All M1 / M2 contacts are wired to the blower motor so that any sequencer that is energized will keep the blower ON.

*24A34-15 heat pump control*

Timings	Switches	Timings on 1-3	Timings off 1-3	Model number	Item number
1	1	1-60	75-95	24A34-15	24A34 015S1

*Electrical ratings - normally open contacts 1-3*

Inductive (motor) full load 120 vac	Inductive (motor) full load 240 vac	Inductive (motor) locked rotor 120 vac	Inductive (motor) locked rotor 240 vac	Resistive (non-inductive) 120 vac	Resistive (non-inductive) 240 vac	Pilot duty
14.0A	7.0A	72.0A	42.0A	25.0A, 3000W	5.0A, 6000W	120 VAC 125 VA, 240 VAC 125 VA

*Electrical ratings - normally closed contacts 1-2*

Vac	Resistive (non-inductive) watts	Resistive (non-inductive) amps	Pilot duty
120	1200	10.0	125 VA
240	1200	5.0	125 VA



24A01G-3

# Level-Temp Control for electric heat

Provides silent operation and narrow differential control for heating or cooling installations.

## Features

- Level-Temp allows low voltage 2-wire thermostat to control line voltage loads such as baseboard heaters
- Conduit hub or screw mounting
- Ideal for all types of electrical heat
- Non-critical mounting angle. Universal break-off mounting tabs
- Dual Level-Temp capable of controlling two separate loads

## Specifications

24A01 and 24A05 dimensions ..... 1.88"H X 4.50"W X 2.44"D  
 24A06 dimensions ..... 3.81"H X 4.81"W X 2.13"D  
 Switch action ..... SPST Normally Open, Single or Dual  
 Average time delay ..... .45 Seconds  
 Dual Ambient temperature range ..... -20 to +120°F  
 UR/CUR file number ..... E12615

### Single level temps - Normally open

Input voltage / frequency	Thermostat current	A. C. Resistive (non-inductive)	Inductive (motor) full load	Inductive (motor) locked rotor	Model number	Item number
240 VAC / 60 Hz	0.2A	25A, 6000W, 240 VAC	12A, 240 VAC	72A, 240 VAC	24A01G-3	24A01G003S1
347 VAC / 60 Hz	0.2A	17A, 5900W, 347 VAC	—	—	24A01Z-10	24A01Z010S1
120 VAC / 60 Hz	0.2A	25A, 3000W, 120 VAC	16A, 120 VAC	96A, 120 VAC	24A05A-1	24A05A001S1
208 VAC / 60 Hz	0.2A	22A, 5200W, 208 VAC	12A, 208 VAC	72A, 208 VAC	24A05E-1	24A05E001S1
277 VAC / 60 Hz	0.2A	22A, 6000W, 277 VAC	—	—	24A05Z-1	24A05Z001S1
208 VAC / 60 Hz	0.2A	25A, 5200W, 208 VAC	12A, 208 VAC	72A, 208 VAC	24A07E-1	24A07E001S1
240 VAC / 60 Hz	0.2A	25A, 6000W, 240 VAC	12A, 240 VAC	72A, 240 VAC	24A07G-1	24A07G001S1

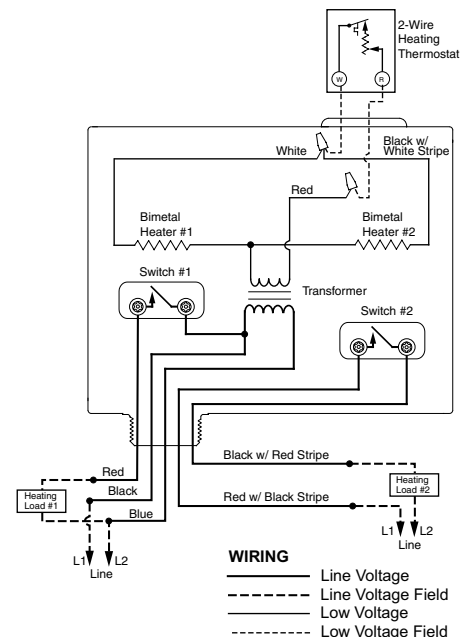
✦ Indicates Canadian Model Number: Call 1-800-305-6953 to order.

### Dual level temps controls two independent loads - Normally open

Input voltage / frequency	Thermostat current	A. C. Resistive (non-inductive)	Inductive (motor) full load	Inductive (motor) locked rotor	Model number	Item number
240 VAC / 60 Hz	0.2A per switch	25A, 6000W, 240 VAC	12A, 240 VAC	72A, 240 VAC	24A06G-1	24A06G001S1

① Electrical ratings apply to each switch load  
**Note:** Delay approximately 30 seconds opening and 60 seconds closing.  
 Replaces Honeywell R841 Series

### 24A06 dual level temp wiring





754-1

# 750 Series Electric Water Heater Controls

Surface mount temperature sensing controls.

## Features

- High electrical capacity
- Snap-Action contact
- Long life-proven reliability
- Adjustable control or manual reset styles

## Specifications

Agency .....UR/CUR, CSA

### 750 Series Electric Water Heater Controls

Description	Switch action	Range	A.C. Electrical ratings (non-inductive) 120 / 240 vac	A.C. Electrical ratings (non-inductive) 277 vac	A.C. Electrical ratings (non-inductive) 480 vac	Model number	Item number
DPST limit (manual reset)	Open on Rise	170°F fixed (77°C)	—	40.0A	25.0A	754-1	07 54 001S1
SPST thermostat	Open on Rise	90 to 150°F (32 to 66°C)	30.0A	25.0A	12.5A	755-1	07 55 001S1
754-1 + 755-1	N/A	N/A	30.0A	25.0A	12.5A	755-50	07 55 050S1
SPDT thermostat	Open 1-2 on Rise	90 to 150°F (32 to 66°C)	30.0A	25.0A	12.5A	756-1	07 56 001S1
754-1 + 756-1	N/A	N/A	30.0A	25.0A	12.5A	756-50	07 56 050S1



37C73U-168

# 37C Series Gas Hot Water Heater Controls

Replacement for standard gas water heater controls.

## Features

- Automatic shut-off of main and pilot gas in the event of pilot failure
- Pilot gas cock with safe lighting feature and filter
- Temperature adjustment
- Manifold pressure tap
- Built-In E.C.O. (Energy Cut Off) non-cycling high limit

## Specifications

Inlet size..... 1/2" NPT  
 Outlet size..... 1/2" inverted flare  
 Outlet adapter fittings..... 1/2" inverted flare X 3/8" NPT reducer adapter  
 ..... 1/2" X 1/2" inverted flare outlet extension adapter  
 Mounting.....3/4" NPT, 4-1/2" bulb insertion length  
 Pilot connection ..... 1/4" compression fitting  
 CSA/CUS certification number..... 1083351

### 37C Series Gas Hot Water Heater Controls

Family brands of equipment	Replaces oem model number	Gas type	Regulator setting	Temperature range	Shank length	Fittings included	Model number	Item number
A. O. Smith, Robertshaw	Consult WR Cross Reference	Natural Gas (Right hand threads)	Main 3.5" W.C., Pilot 4.0" W.C.	70 to 160°F (21 to 71°C)	1-1/4"	Outlet adapter fittings	37C73U-168	37C73U168S1
A. O. Smith, State Industries, American Water Heater	Consult WR Cross Reference	L.P. Gas (Left hand threads)	Main 10.0" W.C., Pilot 10.0" W.C.	70 to 160°F (21 to 71°C)	1-1/4"	Left hand outlet extension fittings: 1/2" LH x 1/2" LH inverted flare and 1/2" LH x 3/8" LH inverted flare	37C72U-185	37C72U185S1
A. O. Smith	37C73U-274	Natural Gas	Main and Pilot 4.0" W.C.	70 to 160°F (21 to 71°C)	2-1/2"	N/A	37C73U-171	37C73U-171
A. O. Smith	37C73U-640	Natural Gas	Main and Pilot 4.0" W.C.	70 to 160°F (21 to 71°C)	1-1/4"	N/A	37C73U-173	37C73U-173
A. O. Smith	37C73U-641	Natural Gas	Main and Pilot 4.0" W.C.	70 to 160°F (21 to 71°C)	2-1/4"	N/A	37C73U-172	37C73U-172
A. O. Smith	37C73U-652	Natural Gas	Main 4.0" W.C., Pilot 5.0" W.C.	70 to 160°F (21 to 71°C)	1-1/4"	N/A	37C73U-174	37C73U-174
Rheem	37C73U-836	Natural Gas	Main 4.0" W.C., Pilot 4.9" W.C.	70 to 160°F (21 to 71°C)	1"	N/A	37C73U-170	37C73U-170



37E73A-903

## 37E Series Intelli-Vent Controls

Power vented water heater gas combination control, ignition and thermostat.

### Features

- Intelli-Vent combines gas, ignition and thermostat into one control
- Right angle with 1/2" N.P.T. inlet and 1/2" inverted flare outlet
- 70° to 160° range
- Regulation range 20,000 to 150,000 BTU's
- Natural gas only

### Specifications

Operating voltage..... 120 VAC, 60 HZ  
 Ignitor load..... 2 Amps Maximum  
 Inducer draft motor..... 3 Amps Full Load, 4 Amps Locked Rotor  
 Range of regulation (BTU / Hr.) ..... 20000 - 150,000 BTU / Hr.  
 1.0" Pressure drop capacity..... 100,000 BTU / Hr.  
 ..... (1000 BTU / FT3, 0.64 specific gravity Natural Gas)  
 Maximum inlet pressure..... 1/2 PSI  
 Ambient temperature rating..... 32°F to 160°F (0°C to 70°C)  
 CSA/CUS certification number..... 1280281

### 37E Series Intelli-Vent Controls

Replaces oem model number	Original equipment manufacturer	Model number	Item number
184960, 9003691005, 37E73A-303	A.O. SMITH, STATE INDUSTRIES	37E73A-903	37E73A-903B1
9005964005, 37E73A-306	STATE INDUSTRIES	37E73A-906	37E73A-906B1
56000152A, 37E73A-318	GIANT	37E73A-918	37E73A-918B1
GSW 64020, 37E73A-321	GSW	37E73A-921	37E73A-921B1
GSW 64021, 64021, 37E73A-322	GSW (WHITE-RODGERS MODEL NUMBER)	37E73A-922	37E73A-922B1
SP13845D, 37E73A-327	RHEEM	37E73A-927	37E73A-927B1



11E79-901

## Integrated Water Heater Control

Solid state thermostat control for gas fired commercial water heaters.

### Features

- Provides relay switched output for damper or inducer fan applications and a "Call for Heat" signal and power to energize a gas valve
- Receives input signals from a temperature probe and Electric Cutoff (ECO)
- Controls temperature with an integrated temperature control knob
- Provides diagnostic LED's to trouble shoot system faults and issues

### Specifications

Input & frequency..... 120 VAC, 60 Hz  
 XFMR sec. current..... 1.5 A @ 24 VAC  
 Field output (DD4, DD2) ..... 1.5A @ 24 VAC  
 Temperature set-point range ..... 20°F-180°F  
 CSA/CUS certification number..... 1028064

### Integrated water heater control - cross reference table

Replaces oem model	Temperature range	Model number	Item number
11E79-101, 11E79-301	120 to 180°F	11E79-901	11E79-901



11B79-3

# Gas Water Heater Control

Commercial water heater control with built in ECO direct replacement for A.O.Smith 192828-000.

## Features

- All bulbs are full direct immersion - no immersion well required
- Case element has a bulb for the ECO and thermostat
- Thermostat has a remote bulb with an integral to remote bulb volume ratio of 3:1
- Remote capillary routed through immersion nut for strain relief
- Temperature regulating device for use in applications not exceeding 180°F (82°C)

## Specifications

Case element..... 3/4" NPT, 2-3/4" shank, 4.63" beyond thread  
 Remote element..... 3/4"NPT, compression fitting on 1-1/2" stud, 5 1/4" beyond stud  
 CSA/CUS certification number..... 1070508

### Gas Water Heater Control

Thermostat electrical rating	Thermostat switch action	E.C.O. Electrical rating	E.C.O. Switch action	Model number	Item number
24 VAC - 0.75 Amp 0.25 to 1.0 VDC - 0.25 Amp 10 F.L.A., 60 L.R.A., 120 VAC	Open on Rise Differential: Fixed 4°F (2.2°C)	24 VAC - 0.75 Amp 0.25 to 1.0 VDC - 0.25 Amp	Open on Rise @ 205°F (96°C) Differential: Non-Cycling Manual Reset	11B79-3	11B79-3



1311-102

# 1300 Series Hydronic Zone Valves

1300 Series valves for zoning systems up to 50 PSI operate quietly and efficiently providing years of reliable service.

## Features

- Self-aligning barrel-type valve stem design
- Made of a corrosion-resistant stainless steel
- Motor can be removed from valve assembly without draining system
- Built-in auxiliary contacts to control burner or circulator relay
- Automatic recycling manual operator shows valve position at all times
- Screw terminal wiring panel for added convenience

## Specifications

Electrical ratings.....	24 VAC
.....	1311 - 0.4A
.....	1361 - 0.2A
.....	Aux Switch - 2.0A

**3-Wire, 24V valves with screw terminal wiring panel and auxiliary switch**  
(See table at bottom for compatible thermostats)

Tubing Size (I.D.)	24 Vac thermostat circuit rating	Time cycle	Maximum differential across valve	Maximum Water temp.	Maximum system pressure	Flow capacity cv	Friction loss equivalents ft. of tubing	Model number	Item number
3/4"	0.4A ①	Open: 45 seconds Close: 45 seconds	15 PSI	240°F (116°C)	50 PSI	23.5 ③	2.5	1311-102	13 11 102S1
1"	0.4A ①	Open: 45 seconds Close: 45 seconds	15 PSI	240°F (116°C)	50 PSI	37.0 ③	3.5	1311-103	13 11 103S1
1-1/4"	0.4A ①	Open: 45 seconds Close: 45 seconds	15 PSI	240°F (116°C)	50 PSI	42.2 ③	6.5	1311-104	13 11 104S1

**2-Wire, 24V valves with screw terminal wiring panel and auxiliary switch**

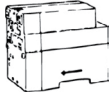


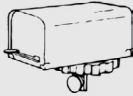



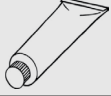
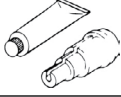
Tubing size (I.D.)	24 Vac thermostat circuit rating	Time cycle	Maximum differential across valve	Maximum water temp.	Maximum system pressure	Flow capacity cv	Friction loss equivalents ft. of tubing	Model number	Item number
3/4"	0.2A ②	Open: 45 seconds Close: 60 seconds	15 PSI	240°F (116°C)	50 PSI	23.5 ③	2.5	1361-102	13 61 102S1
1"	0.2A ②	Open: 45 seconds Close: 60 seconds	15 PSI	240°F (116°C)	50 PSI	37.0 ③	3.5	1361-103	13 61 103S1
1-1/4"	0.2A ②	Open: 45 seconds Close: 60 seconds	15 PSI	240°F (116°C)	50 PSI	42.2 ③	6.5	1361-104	13 61 104S1

- ① Valve current is 0.4A only during opening or closing. For proper anticipation, select thermostat designed for use with a 3-wire zone valve.
- ② Valve current is 0.52A when opening but 0.2A when fully open: therefore set anticipator for 0.2A.
- ③ GPM @ 1 PSI drop.

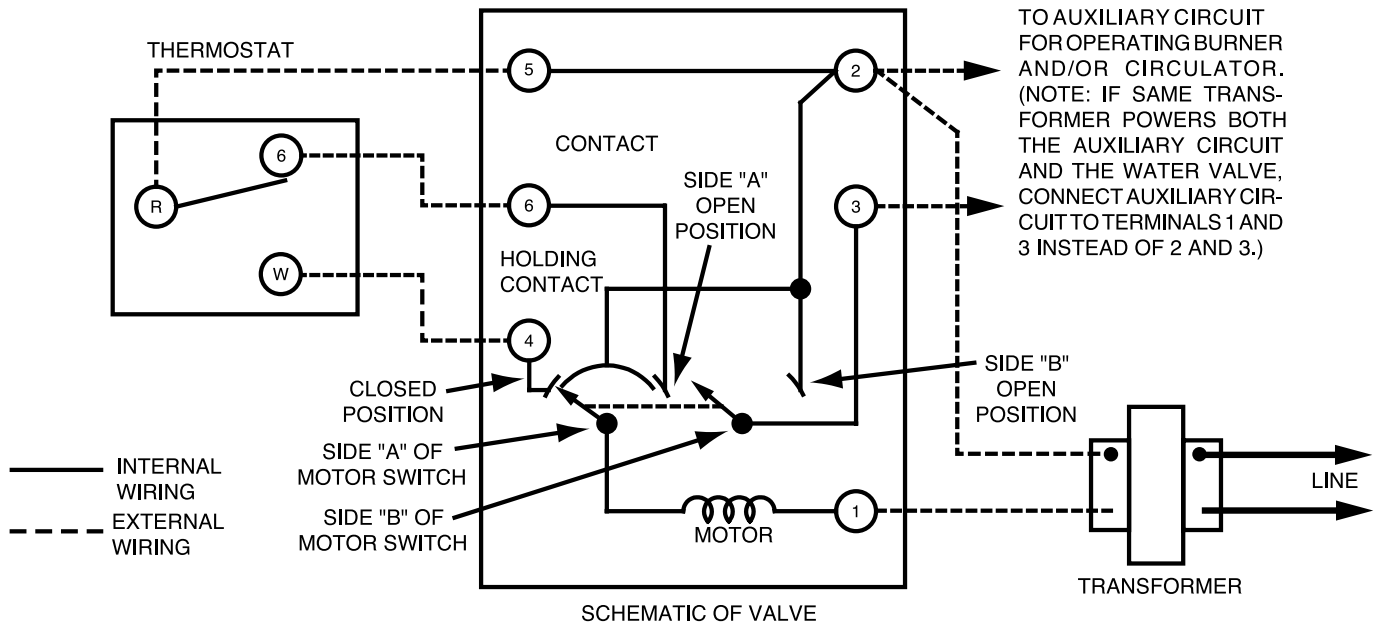
### 1311 Compatible thermostats table

Mechanical/ digital	Model number	Item number	Upgrade model number	Upgrade item number	Mechanical/ digital
Mechanical	1E56N-444	1E56N-444	1F95-0671	1F95-0671	Premium Digital
Mechanical	1F56N-444	1F56N-444	1F95-0680	1F95-0680	Premium Digital
Digital	1F85U-22NP	1F85U-22NP	1F95-1280	1F95-1280	Premium Digital
Digital	1F85U-22PR	1F85U-22PR	1F95-1291	1F95-1291	Premium Digital
Digital	1F85U-42NP	1F85U-42NP	1F95EZ-0671	1F95EZ-0671	Premium Digital
Digital	1F85U-42PR	1F85U-42PR	1F97-1277	01F97 1277	Premium Digital

Parts and accessories

Image	Description	Model number	Item number
	1300 Hydronic Zone Valve Motor assemblies For 1311-102, -103, -104 For 1361-102, -103, -104 Water seal replacement kit not included	F19-0097 F19-0104	F0019 009700S1 F0019 010400S1
	1300 Hydronic zone valve assemblies 1311-102 and 1361-102 (3/4") 1311-103 and 1361-103 (1") 1311-104 and 1361-104 (1-1/4")	F84-0433 F84-0434 F84-0435	F0084 043300S1 F0084 043400S1 F0084 043500S1
	1300 Hydronic zone water seal Replacement (Quad ring, "O" ring, Tru-arc ring and cotter pin) 1311-102 and 1361-102 (3/4") 1311-103 and 1361-103 (1") 1311-104 and 1361-104 (1-1/4")	F92-0227 F92-0228 F92-0229	F0092 022700S1 F0092 022800S1 F0092 022900S1
	13A00 Hydronic zone power head (includes seal ring) For 2-way zone Valves 25 VAC with conduit hub 25 VAC with plug-in panel that includes an auxiliary switch	F19-0181 F19-0187	F0019 018100S1 F0019 018700S1
	13A00 Hydronic zone motor 24 VAC motor	F19-0190	F0019 019000S1
	13A00 Hydronic zone valve disc Contains one disc, spring, E-ring and body seal ring	F84-1215	F0084 121500S1
	Hydronic well adapter for 1100 series bulbs	F71-0924	F0071 092400S1
	Hydronic well heat transfer compound	F145-0163	F0145 016300S1
	Hydronic well adapter and heat transfer compound F71-0924 and F145-0163 packed together	F145-0650	F0145 065000S1

1311 Three-wire zone valve



TERMINALS 1, 2 = POWER TO VALVE  
 1 = 24 VAC NEUTRAL  
 2 = 24 VAC HOT

TERMINALS 5,4,6 = SPDT THERMOSTAT  
 5 = POWER (SAME AS 2 INTERNALLY)  
 4 = OPENS VALVE  
 6 = CLOSSES VALVE

TERMINALS 2, 3 = AUXILIARY SWITCH  
 2, 3 BECOME SAME POINT ON CALL FOR HEAT

TERMINALS 1, 3 = POWER OUT TO AUXILIARY CIRCUIT  
 ON CALL FOR HEAT

**Troubleshooting:**

1. Attach a voltmeter to terminals 1 and 2. Power (24 volts) should always be present on 1 and 2. If power is interrupted check transformer or power source.
2. With a voltmeter attached as above, jumper terminals 5 and 4 to verify the valve opens. If power is present on 1 and 2 but the valve fails to open check connections. Replace motor assembly (replacement Motor # F19-0097) if condition persists. When the valve opens, break the connection between 5 and 4 and jumper between 5 and 6. The valve should close. If the valve fails to close replace motor assembly.
3. Terminals 2 and 3 (auxiliary circuit) become the same point electrically when the valve opens. Because terminal 2 is 24 volts hot, a voltmeter should read 24 volts between terminal 3 and terminal 1 (neutral) when the valve is open.

**Note:** If the auxiliary circuit terminals (2 and 3) are being attached to a control circuit with a separate transformer the transformers must be in phase or one transformer may be damaged. If phasing the transformers is not possible a 24 volt isolation relay can be installed with the coil attached to terminals 1 and 3 and the contacts can be used to operate the control circuit. The relay will energize when the valve opens.

For complete installation instructions visit our website.



✦ ZSW34NCA

# Canada "Z" Series

Exclusive Canadian Direct-Connect Zone Valves - flare, sweat and NPT models.

## Features

- Return spring design & stainless steel for long life
- Swing-type ball valve made from EPDM (Ethylene Propylene Polymer) & Rotating design results in less wear on valve & Raised ball design ensures positive valve closure and even surface wear
- Gears made from heavy 14 gauge brass for durable long life
- Not for steam systems

## Specifications

Operating voltage..... 24 VAC, 50/60 Hz  
 Connection ..... 18" leads  
 Motor type ..... Electric synchronous, spring return  
 Flow direction ..... 2-way, straight through

### Canada "Z" Series

Series	Pipe size	Pipe connection	Flow capacity cv	Auxiliary switch	De-energized position	ΔP	Max. system pressure	Max. water temp.	Canada ✦ model number	Canada ✦ item number
Z Series	1/2"	Inv. Flare	3.5	Yes	NC	20 PSI	142 PSI	110°C	ZINV12NCA	ZINV12NCA
Z Series	1/2"	Inv. Flare	3.5	Yes	NO	20 PSI	142 PSI	110°C	ZINV12NOA	ZINV12NOA
Z Series	3/8"	Flare	3.5	No	NO	20 PSI	142 PSI	110°C	ZFL38NO	ZFL38NO
Z Series	3/8"	Flare	3.5	No	NO	20 PSI	142 PSI	110°C	ZFL38NO-34AD*	ZFL38NO-34AD*
Z Series	3/8"	Flare	3.5	No	NC	20 PSI	142 PSI	110°C	ZFL38NC	ZFL38NC
Z Series	3/8"	Flare	3.5	No	NC	20 PSI	142 PSI	110°C	ZFL38NC-34AD*	ZFL38NC-34AD*
Z Series	3/8"	Flare	3.5	Yes	NC	20 PSI	142 PSI	110°C	ZFL38NCA	ZFL38NCA
Z Series	1/2"	Sweat	3.5	Yes	NC	20 PSI	142 PSI	110°C	ZSW12NCA	ZSW12NCA
Z Series	3/4"	Sweat	3.5	Yes	NC	20 PSI	142 PSI	110°C	ZSW34NCA	ZSW34NCA
Z Series	3/4"	Sweat	3.5	No	NO	20 PSI	142 PSI	110°C	ZSW34NO	ZSW34NO
Z Series	1"	Sweat	3.5	Yes	NC	20 PSI	142 PSI	110°C	ZSW1NCA	ZSW1NCA
Z Series	1"	Sweat	7.0	Yes	NC	20 PSI	142 PSI	110°C	ZSW1NCA7C	ZSW1NCA7C
Z Series	1/2"	NPT	3.5	Yes	NC	20 PSI	142 PSI	110°C	ZNPT12NCA	ZNPT12NCA
Z Series	1/2"	NPT	3.5	No	NO	20 PSI	142 PSI	110°C	ZNPT12NO	ZNPT12NO
Z Series	3/4"	NPT	3.5	Yes	NC	20 PSI	142 PSI	110°C	ZNPT34NCA	ZNPT34NCA
Z Series	1"	NPT	3.5	Yes	NC	20 PSI	142 PSI	110°C	ZNPT1NCA	ZNPT1NCA
Z Series	1"	NPT	3.5	Yes	NC	20 PSI	142 PSI	110°C	ZNPT1NCA7C	ZNPT1NCA7C
Z Series EZ-top	3/8"	Flare	3.5	Yes	NC	20 PSI	142 PSI	110°C	13FL38NCA	13FL38NCA
Z Series EZ-top	1/2"	Inv. Flare	3.5	Yes	NC	20 PSI	142 PSI	110°C	13ZINV12NCA	13ZINV12NCA

✦ Indicates Canadian Model Number: Call 1-800-305-6953 to order.  
 \* With (2) 3/4" sweat adapters.

# Automatic Changeover Switch



752-1

SPDT control provides automatic change-over of thermostat to operate zone valve on combination hot and chilled water systems.

## Features

- Epoxy resin seal protects bimetallic disc and Snap-Action contacts from dust, dirt and corrosion
- Furnished with removable spring clip to attach control to tubing
- SPDT switch connects heating side of thermostat to two-wire zone valve when hot water is circulated through tubing
- SPDT switch connects cooling side of thermostat to two-wire zone valve when chilled water is circulated through tubing
- Curved sensing element provides maximum contact with tubing

## Specifications

Connectors ..... 12" red, brown and black leads, 105°C insulated, No. 18 wire  
 Temperature settings..... Red-Black: Open on Rise @ 85°F, Close @ 70°F  
 ..... Red-Brown: Close on Rise @ 85°F, Open @ 70°F  
 Operating temperature..... 221°F maximum

### Automatic Changeover Switches - Types for use with 1/2" tubing (5/8" o.D.)

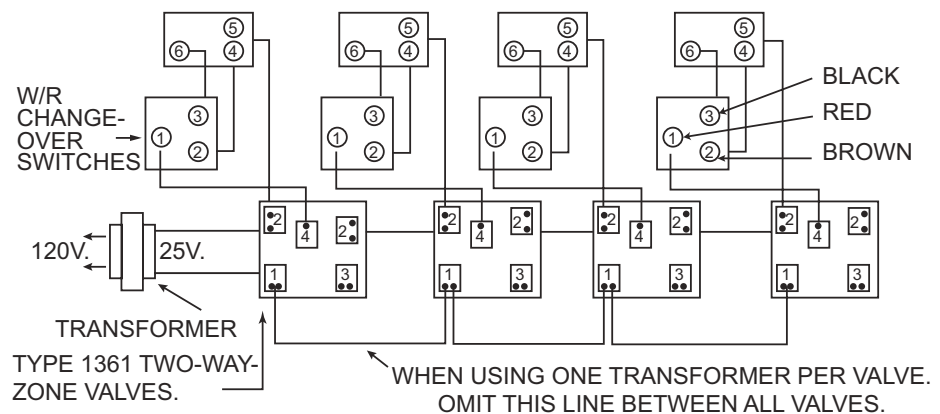
Switch action	Temperature settings	Leads	Amps. Inductive full load at 120 vac	Amps. Inductive full load at 240 vac	Amps. Inductive locked rotor at 120 vac	Amps. Inductive locked rotor at 240 vac	Amps. Resistive at 120 / 240 / 277 Vac	Pilot duty	Conduit connector	Model number	Item number
SPDT	Red - Black Open at 85° Plus/Minus 6°; Red to Brown Open at 70° Plus/Minus 6°	12" With Stripped Ends	7.5A	3.75A	45.0A	22.5A	15A	15A at 120 / 240 / 277 VAC	No	752-1	07 52 001S1
SPDT	Red - Black Open at 85° Plus/Minus 6°; Red to Brown Open at 70° Plus/Minus 6°	12" With Stripped Ends with Conduit Connector	7.5A	3.75A	45.0A	22.5A	15A	15A at 120 / 240 / 277 VAC	Yes	752-2	07 52 002S1

### Contractor tip:

Use with 1361 Zone Valves for heat / cool applications.

### Automatic change-over switch wiring

Typical diagram using Type 1361 valves (25 volts) with Changeover Switch. Boiler, chiller, and circulator operation are independent of thermostat demand.





11D18-1

# 1100 Series Well Immersion Temperature Controls

Hydronic (hot water) controls for use as high limit, reverse action or SPDT switching action.

## Features

- Extra capillary length for extended shank wells
- Special screw terminals with "ears" that securely hold solid and stranded wires
- Screwdriver-adjustable differential with direct-read indicator
- Knockouts on top and bottom and plenty of wiring room
- Hydraulic action element - fast acting
- May be mounted either horizontal or vertical

## Specifications

Dimensions ..... 5.38"H + 2.32" coil X 2.56"D  
 Finish ..... Grey  
 UL/CUL file number ..... E12615

## Contractor tip - Testing automatic temperature controls:

To verify a control is opening and closing properly, disconnect all power before testing. Testing must be performed with the sensing element at a temperature within the setting range of the control. For most hydronic controls with a range of 100 to 240°F, a pan of hot water is sufficient to reach the control range. Attach an ohmmeter or continuity tester across the Open on Rise contacts. Lower the temperature setting dial to the lowest setting. If the lowest setting is below the temperature of the sensing element minus the differential of the control, the contacts should be open. Raise the temperature dial slowly. When the setting is raised above the temperature of the sensor, the contacts should close.

### Types with bulbs directly interchangeable with honeywell - (3-9/16" x 3/8") No wells included

Range	Differential	Switch action	Motor rating (full load)		Valves and relays		Model number	Item number
			120 Vac	240 Vac	24 Vac	0.3-12 VDC		
100 to 240°F (38 to 116°C)	5 to 45°F (3 to 25°C)	Open on Rise	10.0A	6.0A	6.0A	1.0A	11D18-1 ①	11D18 001S1
100 to 240°F (38 to 116°C)	7 to 45°F (4 to 25°C)	SPDT	7.4A	3.7A	2.9A	—	11D31-1	11D31 001S1

### Types with tapered bulbs - (2-7/16" x 7/16") All types include 1/2" standard shank well, unless otherwise specified

Range	Differential	Switch action	Motor rating (full load)		Valves and relays		Model number	Item number
			120 Vac	240 Vac	24 Vac	0.3-12 VDC		
100 to 240°F (38 to 116°C)	7 to 45°F (4 to 25°C)	SPDT	7.4A	3.7A	2.9A	—	1131-102 ①	11 31 102S1
100 to 240°F (38 to 116°C)	5 to 45°F (3 to 25°C)	Open on Rise	10.0A	6.0A	6.0A	1.0A	11B18-101 ①	11B18 101S1

① Has U.L. approved adjustable dial stop, factory set at 150°F maximum.  
 See White-Rodgers General Information for full electrical ratings. 11D18-1, 11B18-101 are rated at HTV and 11D31-1, 1131-102 are rated at HH.

## Parts and accessories

Image	Description	Model number	Item number
	hydronic well adapter for 1100 series bulbs	F71-0924	F0071 092400S1
	Hydronic well heat transfer compound	F145-0163	F0145 016300S1
	Hydronic well adapter and heat transfer compound F71-0924 and F145-0163 packed together	F145-0650	F0145 065000S1



F89-0211

# Immersion Wells & Packing Nuts

1/2" and 3/4" NPT sizes for hydronic element insertion.

## Features

- Wells are used where it is desired that the control operates from the temperature of a liquid in a closed system
- The bulb of the control can be removed from an immersion well in the tank wall with out draining the boiler tank
- The packing nut can be used with any of the remote bulb types listed
- Packing nuts permit closer control than wells because the bulb is directly immersed in the liquid

## Specifications

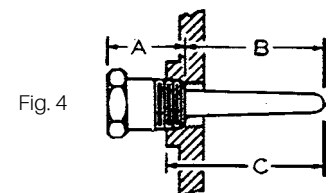
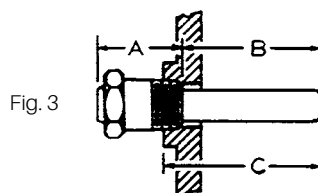
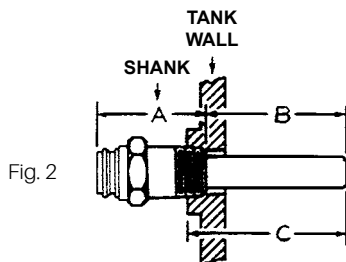
Application note.....For use in liquids that are not corrosive to brass and copper  
 .....Not recommended for use above 100 psi, 250°F (120°C)

### Universally interchangeable wells

Basic types well is used with	Bulb size of control used	Well description pipe size npt	Well description shank	Figure number	Dimensions a	Dimensions b	Dimensions c	Model number	Item number
All	3-1/2 x 3/8"	1/2"	Standard	2	1-13/16"	3"	3-5/16"	F89-0211	F0089 021100S1
All	3-1/2 x 3/8"	1/2"	Std. Extended	2	3-5/16"	3"	3-5/16"	F89-0212	F0089 021200S1
All	3-1/2 x 3/8"	3/4"	Standard	2	1-13/16"	3"	3-5/16"	F89-0213	F0089 021300S1
1609, 1629, 2A23	5-3/4 x 3/8"	1/2"	Standard	3	15/8"	6"	6-5/16"	F89-0027	F0089 002700S1
11B06, 11B37, 1182	3-1/2 x 7/16"	3/4"	Standard	3	15/8"	2-13/16"	3-1/8"	F89-0033	F0089 003300S1
11B06, 11B37, 1182	3-1/2 x 7/16"	1/2"	Standard	3	15/8"	2-13/16"	3-1/8"	F89-0036	F0089 003600S1
All	2-15/16 x 7/16"	1/2"	Standard	3	15/8"	2-13/16"	3-1/2"	F89-0148	F0089 014800S1
11B18, 11B05, 11B55, 1131	—	1/2"	Standard	4	1-5/8"	2-13/16"	3-1/8"	F89-0062	F0089 006200B1
11B18, 11B05, 11B55, 1131	—	3/4"	Standard	4	1-5/8"	2-13/16"	3-1/8"	F89-0063	F0089 006300B1

### Packing nut

Description	Figure number	Model number	Item number
Packing nut with 1/2" threads	1	F55-0088	F0055 008800B1





1127-2

# 1100 Series Strap-On Style Temperature Controls

Attach directly to surface of pipe. For use as high limit, reverse acting or SPDT switching action control.

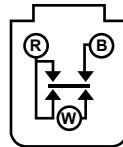
## Features

- Hydraulic action element can be mounted in any position - no leveling required
- Dustproof steel case
- Special screw terminals with "ears" securely hold solid and stranded wires
- Includes pipe strap and mounting screws

## Specifications

Dimensions ..... 6.88"H (includes plate) X 2.32"W X 3.19"D  
 Finish ..... Grey  
 UL/CUL file number ..... E12615

SPDT Contact Structure  
 HH Rated Controls  
 Switch Action  
 R-B Open on Rise  
 R-W Close on Rise



### 1100 Series Strap-On Style Temperature Controls

Range	Differential	Switch action	Motor rating (Full load) 120 vac	Motor rating (Full load) 240 vac	Valves and relays 24 vac	Valves and relays 0.3-12 Vdc	Model number	Item number
100 to 240°F (38 to 116°C)	Fixed 10°F (5.5°C)	SPDT	7.4A	3.7A	2.9A	—	1127-2 ①	11 27 002S1

① Has U.L. approved adjustable dial stop, factory set at 150°F maximum.  
 See White-Rodgers General Information for full electrical ratings.



90-113

# 90-112 Thru 90-130 Fan Control Center

Transformer and relay combination for easy installation on a 4" X 4" junction box.

## Features

- Line voltage connections pre-wired
- Energy limiting Class II transformer design
- Color coded pre-stripped leads
- Low voltage connections on terminal board

## Specifications

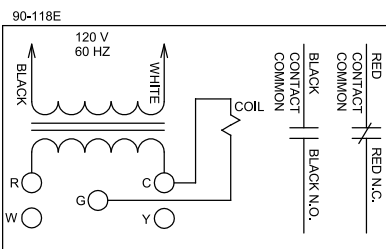
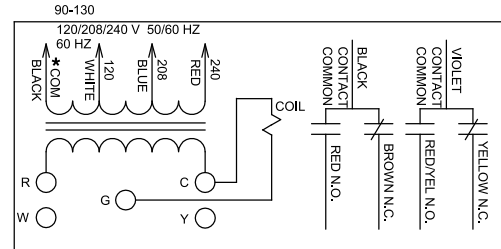
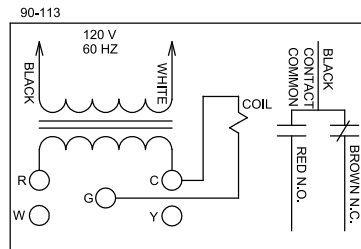
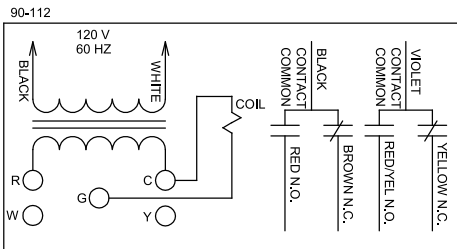
UR/CUR file number.....E73641

### Replacement relay for fan control center

Replaces relay on	Description	Model number	Item number
90-112, 90-113, 90-117, 90-118E, 90-119, 90-130	DPDT Universal Plug-in Relay	90-340	90 340S1

### 90-112 Thru 90-130 Fan Control Center

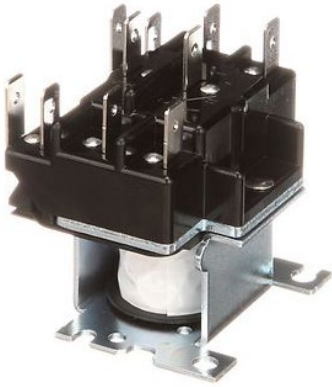
Mars number	Transformer						Relay	Contact ratings				Model number	Item number
	Primary			Secondary				120 Vac (amps)		240 Vac (amps)			
	Voltage	Hz	Connections	Voltage	Va	Connections		Full load	Locked rotor	Full load	Locked rotor		
24010	120	60	Color coded leads, pre-stripped	24V	40	Terminal board with 5 screw terminals	DPDT	13.8	82.8	6.9	41.4	90-112	90 112S1
24013							SPDT					90-113	90 113S1
24012							SPNO / SNPC					90-118E	90 118ES1
24010							DPDT					90-130	90 130S1



When the fan relay transformer is energized and the thermostat completes the connection from R to G the fan relay coil energizes. Line voltage power applied to contact common path travels to selected blower speed tap. Additional terminal Y and W are isolated tie point terminals to connect thermostat wiring to compressor and furnace (if required).

**Note:** Record the lead wire color with its corresponding terminal for future reference. Unused transformer input leads must be insulated.

\* Black is common with respect to transformer winding, not external circuit.



90-340

## 90-340 thru 90-342 Relays

Two pole double throw semi-enclosed relays.

### Features

- Easy to install
- Suited for use in vending machines, appliances, heating and air conditioning applications and general purpose switching
- 90-340 fits fan control centers 90-112, 90-113, 90-118E and 90-119

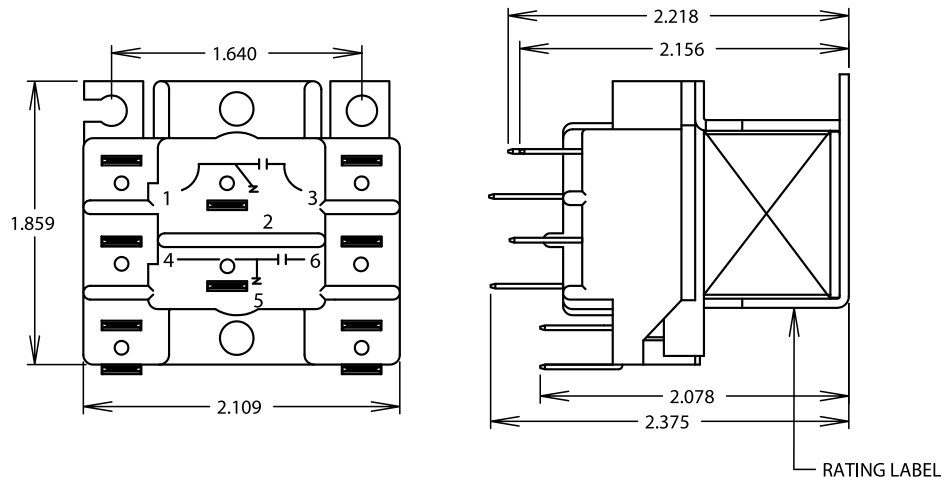
### Specifications

Temperature range.....	-40°F to 130°F
Mechanical life (no load) .....	1,000,000 operations, 120 operations/min.
Electrical life (rated load) .....	100,000 operations, 6 operations/min.
.....Load test making inrush ratings (0.4 to 0.5 Power Factor)	
.....Breaking 100% continuous rating (0.65 to 0.8 Power Factor)	
Weight (approximate).....	6 oz.
Coils, frequency.....	50 / 60 Hz
Coils, insulation.....	Class B
Coils, termination .....	1/4" Quick Connect
Coils, operate .....	85% of nominal coil voltage; 110% maximum safe operate
Coils, duty cycle.....	Continuous
UR/CUR file number.....	E12139
CSA/CUS certificate number .....	LR13360

90-340 thru 90-342 Relays - Two pole double throw (2pdt) fits fan control center receptacles

Coil voltage (50 / 60 Hz)	Terminals 1-2-3	Terminals 4-5-6	Coil data Dc res.	Coil data ma	Coil data Nom. Va	Coil data inrush va	Model number	Item number
24	Power	Power	17.5	334	9.5	22	90-340	90 340S1
120	Power	Power	420	66	9.5	22	90-341	90 341S1
208 / 240	Power	Power	1600	38	9.5	22	90-342	90 342S1

CONTACT RATINGS  
 12FLA / 60LRA  
 125 VAC  
 6FLA 35LRA  
 240 / 277 VAC  
 15A 277 VAC RES  
 1/2HP 125 / 250 VAC





8A05A-4

# 8A05A Relay & Transformer Combinations

SPDT relay model enclosed with a transformer capable of powering external loads up to 35VA. Ideal for use on boilers without domestic coil. Equally adaptable for zoned and unzoned systems.

## Features

- Low voltage screw terminals - color coded, end stripped line voltage leads
- Internal transformer can power up to 35VA external loads
- Mounts to 4" X 4" junction box
- Dustproof steel case

## Specifications

Transformer.....35 VA maximum connected external load  
 Finish.....Grey  
 Dimensions..... 4.13"H X 4.13"W X 3.13"D  
 UL/CUL file number..... E12615  
 .....CSA

### 8A05A Relay & Transformer Combinations

Input voltage	Switch action	Thermostat current	Contact ratings motor 120 vac full load	Contact ratings motor 120 vac locked rotor	Contact ratings values & relays terminals v1 & v2 30 vac	Contact ratings values & relays terminals v1 & v2 30 vac 0.3-12 Vdc	Model number	Item number
24 VAC, 60 Hz	SPDT	0.17	12.0A/12.0A	60.0A/60.0A	N/A	N/A	8A05A-121	8A05A-121

✦ Indicates Canadian Model Number: Call 1-800-305-6953 to order.



90-293Q

# 90-290Q thru 90-295Q Relays

Used for switching single or two speed fan motors, solenoids, relays, resistive loads and general purpose switching.

## Features

- Compact, totally enclosed design
- For heating and cooling applications and general switching
- Quiet, reliable and economical

## Specifications

Temperature range..... -40° to 150°  
 Mechanical life (no load) ..... 1,000,000 operations, 60 operations/min.  
 Electrical life (rated load) ..... 100,000 operations, 6 operations/min.  
 ..... Load testing making inrush rating (0.4 to 0.5 P.F.);  
 ..... Breaking 100% continuous rating (0.64 to 0.8 P.F.)  
 Weight..... 2.5 oz.  
 UR/CUR file number..... E12139  
 CSA/CUS certificate number ..... LR13360

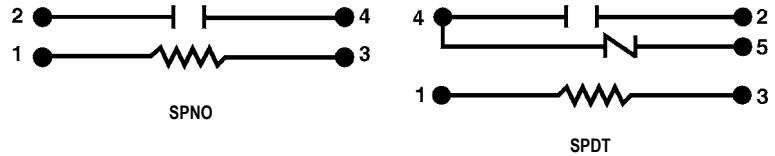
### 90-290Q thru 90-295Q Relays

Coil voltage AC (50/60 hz)	Switch action	Res dc ohms	Coil data nominal current ma	Coil data nominal va sealed	Inrush va	Model number	Item number
24	SPNO	90	125	3	4	90-290Q	90 290QS1
24	SPDT	90	125	3	4	90-293Q	90 293QS1
120	SPNO	2,000	25	3	4	90-291Q	90 291QS1
120	SPDT	2,000	25	3	4	90-294Q	90 294QS1
208/240	SPNO	7,000	12.5	3	4	90-292Q	90 292QS1
208/240	SPDT	7,000	12.5	3	4	90-295Q	90 295QS1

### Contact rating 125 / 250 vac

Inductive	Resistive	Type
8 Amps Continuous 25 Amps. Inrush	16	SPNO
8 Amps Continuous 25 Amps. Inrush	8	SPDT

### Wiring diagrams





90-380

# 90-360 thru 90-486 Relays

Heavy-duty general purpose relay operates in any position.

## Features

- Compact, totally enclosed design
- For heating and cooling applications and general switching
- Quiet, reliable and economical

## Specifications

Temperature range.....-40°F to 150°F  
 Mechanical life (no load) ..... 1,000,000 operations, 120 operations/min.  
 Electrical life (rated load) ..... 100,000 operations, 6 operations/min.  
 ..... Load test making inrush rating (0.4 to 0.5 P.F.)  
 ..... Breaking 100% continuous rating (0.65 to 0.8 P.F.)  
 Coils, frequency..... 50 / 60 Hz  
 Coils, insulation..... Class B  
 Coils, termination ..... 1/4" Quick Connect  
 Coils, operate ..... 85% of nominal coil voltage; 110% maximum safe operate  
 Coils, duty cycle.....Continuous  
 Weight..... 2.3 oz.  
 UR/CUR file number..... E12139  
 CSA/CUS certificate number ..... LR13360

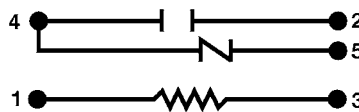
### 90-360 thru 90-486 Relays

Coil voltage ac (50/60 hz)	Switch action	Res dc ohms	Coil data nom. Current ma	Coil data nominal va sealed	Inrush va	Model number	Item number
24	SPNO	77	125	3	4	90-360	90 360S1
24	SPDT	77	125	3	4	90-370	90 370S1
24	SPNO/SPNC	77	125	3	4	90-380	90 380S1
120	SPNO	2,000	25	3	4	90-362	90 362S1
120	SPDT	2,000	25	3	4	90-372	90 372S1
208/240	SPDT	6,050	12.5	3	4	90-374	90 374S1
208/240	SPNO/SPNC	6,050	12.5	3	4	90-384	90 384S1
277	SPNO	10,300	10.8	3	4	90-466	90 466S1
277	SPDT	10300	10.8	3	4	90-476	90 476S1
277	SPNO/SPNC	10300	10.8	3	4	90-486	90 486S1

### Wiring diagrams



SPNO / SPNC



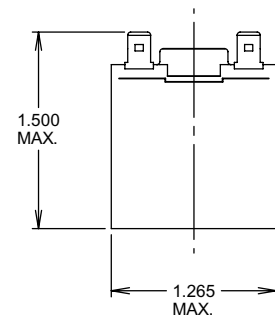
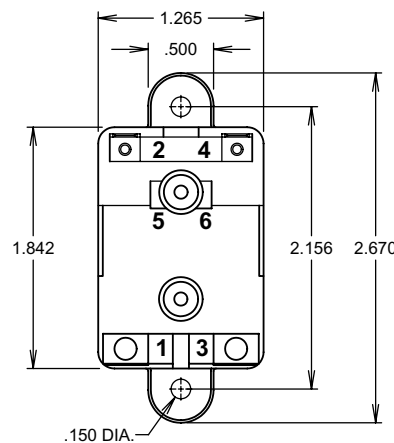
SPDT

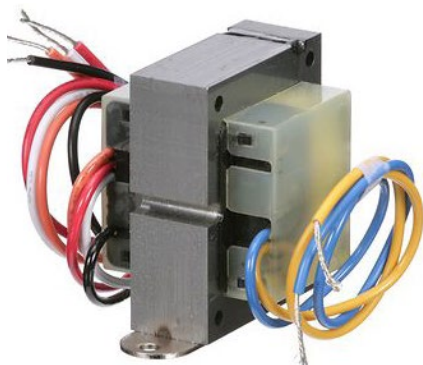


SPNO

### 90-360 THRU 90-486 RELAYS Contact Rating

Inductive	Resistive
12 Amps. Continuous, 60 Amps. Inrush @ 125 VAC	18 Amps. Continuous @ 277 VAC
8 Amps. Continuous, 48 Amps. Inrush @ 250 VAC	





90-T40F3

## 90-T Series Energy Limiting 24 VAC Transformers

For industrial, heating and air conditioning controls applications.

### Features

- Color coded primary leads
- Color coded secondary leads
- Multi-mount styles available

### Specifications

UR/CUR file number..... E507466

#### 90-T series inherently limited 24 vac transformers - Multi-mount with plate (closed construction)

Primary	Sec.	Va	Hz	Primary / sec. Connections	Mars part no.	Jard part no.	Model number	Item number
120 VAC	24 VAC	40	60	Leads / Leads	50302	4011M	90-T40M1	90-T40M1
208 / 240 VAC	24 VAC	40	50/60	Leads / Leads	50303	4021M	90-T40M2	90-T40M2
120 / 208 / 240 VAC	24 VAC	40	60	Leads / Leads	50304	4031M	90-T40M3	90-T40M3

#### 90-T series not inherently limited 24 vac transformers - Multi-mount with plate (closed construction)

Primary	Sec.	Va	Hz	Primary / sec. Connections	Mars part no.	Jard part no.	Model number	Item number
120 / 208 / 240 VAC	24 VAC	50	60	Leads / Leads	50314	5031M	90-T50M3	90-T50M3

#### 90-T series not inherently limited 24 vac transformers - Foot-mount (open construction)

Primary	Sec.	Va	Hz	Primary / sec. Connections	Mars part no.	Jard part no.	Model number	Item number
120 VAC	24 VAC	40	50/60	Leads / Leads	50352	4011F	90-T40F1	90-T40F1
208 / 240 VAC	24 VAC	40	50/60	Leads / Leads	50353	4021F	90-T40F2	90-T40F2
120 / 208 / 240 VAC	24 VAC	40	50/60	Leads / Leads	50354	4031F	90-T40F3	90-T40F3

#### 90-T series not inherently limited 24 vac transformers - Foot-mount (open construction)

Primary	Sec.	Va	Hz	Primary / sec. Connections	Mars part no.	Jard part no.	Model number	Item number
120 / 208 / 240 VAC	24 VAC	50	50/60	Leads / Leads	50308	5031F	90-T50F3	90-T50F3

#### 90-T series not inherently limited 24 vac transformers - Foot-mount (manual reset, open construction)

Primary	Sec.	Va	Hz	Primary / sec. Connections	Mars part no.	Jard part no.	Model number	Item number
120 / 208 / 240 VAC	24 VAC	50	50/60	Leads / Leads	50327	5041C	90-T50C3	90-T50C3
120 / 208 / 240 VAC	24 VAC	60	50/60	Leads / Leads	50327	6041C	90-T60C3	90-T60C3
120 / 208 / 240 VAC	24 VAC	75	50/60	Leads / Leads	50321	7541C	90-T75C3	90-T75C3
120 / 208 / 240 / 480	24 VAC	100	50/60	Leads / Leads	50540	10041C	90-T100C4	90-T100C4



S84-11

## S82 & S84 Energy Limiting 24 VAC Transformers

Various standard configurations of step down transformers designed to power 24 VAC control systems

### Features

- Energy limiting design, unaffected by momentary short circuit
- Continued short circuit of secondary will cause primary winding to open in 1 to 2 minutes without creating a fire hazard
- Maximum ambient temperature is 150°F

### Specifications

UR/CUR file number..... E507466  
 .....CE Approved (S84-11, S84Z-90, S84A-410)

#### S84 series inherently limited 24 vac transformers - Universal mounting models - plate, foot or hub mount

Primary	Sec.	Va	Hz	Primary / sec. connections	Model number	Item number
120 VAC	24 VAC	40 VA	60	Leads / Screw Terminals	S84-11	S84 011S1
120 / 208 / 240 VAC	24 VAC	40 VA	60	Leads / Screw terminals	S84Z-90	S84Z090S1

#### S84 series inherently limited 24 vac transformers - Plate mounted

Primary	Sec.	Va	Hz	Terminations line	Model number	Item number
120 VAC	24 VAC	40 VA	60	Leads / Screw Terminals	S84A-410	S84A410S1

#### S82 series inherently limited 24 vac transformers - Hub mount - class 2 not wet / class 3 wet (C.S.A. Certified and u.L. Listed e11592)

Primary	Sec.	Va	Hz	Primary / sec. connections	Model number	Item number
120 VAC	25 VAC	20 VA	—	Leads / Screw - Spade Terminals	S82A-310	S82A310S1

#### S84 series inherently limited 24 vac transformers - Universal mounted type - plate, foot or hub mount, (Class 2 not wet / class 3 wet (c.S.A. Certified and u.L. Listed)

Primary	Sec.	Va	Hz	Primary / sec. connections	Model number	Item number
120 VAC	25 VAC	40 VA	60	Leads / Screw - Spade Terminals	S84A-310	S84A310S1

✦ Indicates Canadian Model Number: Call 1-800-305-6953 to order.



70-111224

# Type 70 Series D.C. Power Solenoids

Single pole normally open contact, case is dust resistant and isolated from ground.

## Features

- DC Power Solenoid designed to be utilized in multiple applications
- Dust resistant case
- Case is isolated from ground
- SPNO contacts
- Versatile mounting and termination

## Specifications

Dimensions ..... 2.40"H X 3.48"W X 2.47"D  
 Weight..... 14 oz.  
 Temperature range.....-40° to +122°F  
 Terminations, contacts ..... 5/16"-24 UNF-2A thread  
 Terminations, coil..... # 10-32 UNF-2A thread  
 Recommended mounting .....Plunger vertical with cap down  
 Hardware Torque, contact terminal..... 45-55 in. lbs.  
 Hardware Torque, coil terminal..... 12-18 in. lbs.  
 UL file number .....AU2138

### WARNING - FIRE HAZARD

Must be installed in a dry and protected place. Failure to protect solenoid from water and other contaminants could result in fire, property damage, Serious personal injury, or death.

### Type 70 Series D.C. Power Solenoids

Duty cycle	Terminal type	Bracket style	Coil voltage D.C.	Coil resistance IN OHMS @ 25°C	Contact material	Contact rating (Amps)		Model number	Item number
						– Inductive Load normally open continuous	– Inductive Load normally open inrush		
Continuous	3A (Coil Grounded to Case, SPNO)	Standard	12	16	Copper	80	150	70-111225	70 111225S1
Continuous	4 (Isolated Coil, SPNO)	Standard	12	16	Copper	80	150	70-111224	70 111224S1
Continuous	4 (Isolated Coil, SPNO)	Standard	24	60	Copper	50	50	70-117224	70 117224S1
Continuous	4 (Isolated Coil, SPNO)	Standard	36	114	Copper	50	50	70-120224	70 120224S1



120 105711S1

# Type 120 Series D.C. Power Solenoids

Single pole normally open contact, dust resistant, water resistant and case is isolated from bracket.

## Features

- Water resistant
- Capable of handling low and high current requirements
- Versatile mounting and termination

## Specifications

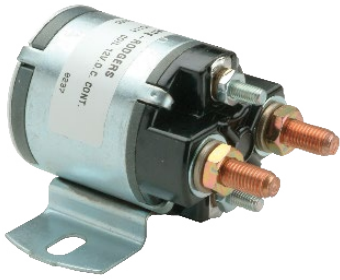
Dimensions ..... 3.09"H X 2.88"W X 2.13"D  
 Dimensions ..... 3.03"H X 3.00"W X 2.50"D L-Shaped Bracket)  
 Weight..... 6.0 oz.  
 Temperature range, intermittent duty.....-20° to +150°F  
 Temperature range, continuous duty.....-20° to +120°F  
 Terminations, contacts ..... 5/16"-24 studs, .495" min. length  
 Terminations, coil..... #10-32, .451&#8221; min. length  
 Recommended mounting ..... Coil terminals up or horizontal  
 Hardware Torque, contact terminal..... 45-55 in. lbs.  
 Hardware Torque, coil terminal..... 12-18 in. lbs.  
 UR file number .....AU2138

### WARNING

Must be used in coil selection for use in 12 volt systems where battery charging may expose coil to continuous, higher-than-rated voltage. 14 volt coils are recommended. White-Rodgers will not be responsible for consequences of misapplied solenoids.

### Type 120 Series D.C. Power Solenoids

Duty cycle	Terminal type	Bracket style	Coil voltage D.C.	Coil resistance in ohms @ 25°C	Contact material	Contact rating (amps) - inductive load Normally open continuous	Contact rating (amps) - inductive load Normally open inrush	Model number	Item number
Continuous	4 (Isolated Coil, SPNO)	Standard	12	16	Silver Alloy	100	400	120-105711	120 105711S1
Continuous	3A	Standard	12	6	Silver Alloy	100	400	120-105851	120 105851S1
Intermittent (30 seconds "ON" maximum and 6 minutes "OFF")	4 (Isolated Coil, SPNO)	Standard	12	6	Copper	80	400	120-106131	120 106131S1
Intermittent (30 seconds "ON" maximum and 6 minutes "OFF")	4 (Isolated Coil, SPNO)	L	12	6	Copper	80	400	120-106132	120 106132S1
Continuous	4 (Isolated Coil, SPNO)	L	14	26	Silver Alloy	100	400	120-107112	120 107112S1



124-105111

# Type 124 Series D.C. Power Solenoids

Single pole normally open, or single pole double throw contacts. Dust resistant and endcaps are isolated from bracket.

## Features

- Double-make or double-break contacts
- Steel enclosure
- Offers high and low current capabilities
- Isolated or grounded coils

## Specifications

Dimensions: 124-105111, -114111, -117111..... 2.19"H X 3.13"W X 3.56"D  
 Dimensions: 124-305111, -314111, 317111..... 2.19"H X 3.13"W X 4.69"D  
 Weight: 124-105111, -114111, -117111..... 16.0 oz.  
 Weight: 124-305111, -314111, 317111..... 19.0 oz.  
 Temperature range.....-40° to +149°F  
 Terminations, contacts ..... 5/16"-24 UNF-2A thread  
 Terminations, coil..... #10-32 UNF-2A thread  
 Recommended mounting ..... Vertical plane with coil terminals up  
 Hardware torque, contact terminal ..... 60 in. lbs. max.  
 Hardware torque, coil terminal ..... 12-18 in. lbs.

### Type 124 Series D.C. Power Solenoids

Duty cycle	Terminal type	Bracket style	Coil voltage D.C.	Coil resistance in ohms @25°C	Contact material	Contact rating (Amps) – inductive load normally open continuous	Contact rating (Amps) – inductive load normally open inrush	Contact rating (Amps) – inductive load normally closed continuous	Contact rating (Amps) – inductive load normally closed inrush	Model number	Item number
Continuous	4 (Isolated Coil, SPNO)	Standard	12	13.2	Silver Alloy	100	400	—	—	124-105111	124 105111S1
Continuous	6 (Isolated Coil, SPDT)	Standard	12	13.2	Silver Alloy	100	400	50	200	124-305111	124 305111S1
Continuous	4 (Isolated Coil, SPNO)	Standard	24	53.0	Silver Alloy	100	400	—	—	124-114111	124 114111S1
Continuous	6 (Isolated Coil, SPDT)	Standard	24	53.0	Silver Alloy	100	400	50	100	124-314111	124 314111S1
Continuous	4 (Isolated Coil, SPNO)	Standard	36	120.0	Silver Alloy	100	400	—	—	124-117111	124 117111S1
Continuous	6 (Isolated Coil, SPDT)	Standard	36	120.0	Silver Alloy	100	400	50	100	124-317111	124 317111S1



586-120111

# Type 586 Series D.C. Power Solenoids

Single pole normally open, or single pole double throw contacts. Water resistant and case is isolated from bracket.

## Features

- Single pole normally open contacts
- DC power solenoid designed to be utilized in multiple applications
- Versatile mounting and termination
- Water & dust resistant case design

## Specifications

Dimensions, 586-105111, -106111, -114111, -117111, -120111 2.90"H X 3.30"W X 3.69"D  
 Dimensions, 586-314111, -317111.....2.90"H X 3.30"W X 4.61"D  
 Weight, 586-105111, -106111, -114111, -117111, -120111.....24.0 oz.  
 Weight, 586-314111, -317111.....26.0 oz.  
 Temperature range.....-40° to +149°F  
 Terminations, contacts.....5/16"-24 UNF-2A thread  
 Terminations, coil.....# 10-32 UNF-2A thread  
 Recommended mounting.....Vertical plane with coil terminals up  
 Hardware torque, contact terminal.....60 in. lbs. max.  
 Hardware torque, coil terminal.....12-18 in. lbs.  
 UR file number.....AU2138

### WARNING

Must be used in coil selection for use in 12 volt systems where battery charging may expose coil to continuous, higher-than-rated voltage. 15 volt coils are recommended. White-Rodgers will not be responsible for consequences of misapplied solenoids.

### Type 586 Series D.C. Power Solenoids

Duty cycle	Terminal type	Bracket style	Coil voltage D.C.	Coil resistance in Ohms @ 25°C	Contact material	Contact rating (Amps) – inductive load normally Open continuous	Contact rating (Amps) – inductive load normally Open inrush	Contact rating (Amps) – inductive load normally closed continuous	Contact rating (Amps) – inductive load normally closed inrush	Model number	Item number
Continuous	4 (Isolated Coil, SPNO)	Standard	12	21.0	Silver Alloy	200	600	—	—	586-105111	586 105111S1
Continuous	4 (Isolated Coil, SPNO)	Standard	15	32.8	Silver Alloy	200	600	—	—	586-108111 <sup>1</sup>	586 108111S1
Continuous	4 (Isolated Coil, SPNO)	Standard	24	84.0	Silver Alloy	200	600	—	—	586-114111	586 114111S1
Continuous	4 (Isolated Coil, SPNO)	Standard	36	189.0	Silver Alloy	200	600	—	—	586-117111	586 117111S1
Continuous	4 (Isolated Coil, SPNO)	Standard	48	336.0	Silver Alloy	200	600	—	—	586-120111	586 120111S1
Continuous	6 (Isolated Coil, SPDT)	Standard	24	53.0	Silver Alloy	200	600	100	200	586-314111	586 314111S1
Continuous	6 (Isolated Coil, SPDT)	Standard	36	120	Silver Alloy	200	600	100	200	586-317111	586 317111S1

Inrush Current: Current applied within the first 1/2 second of contact closure

<sup>1</sup> Ideal for 12V charging systems

FR - filter replacements

CFM	Recommended CFM	A/C tonnage	Input range	Merv	Dimension	Model number	Item number
1400	1000-1600	up to 4.0	up to 160,000	8	20"H X 24"W X 4.38"D	FR1400U-108	FR1400U108
2000	1600-2200	up to 5.5	up to 220,000	8	20"H X 24-1/2"W X 4.38"D	FR2000U-108	FR2000U108

# Media filter cross reference

Nominal size	CFM	Filter manufacturer	Filter model	Cabinet model	Model number (merv 8)	Item number (merv 8)
16"H X 25"W X 5"D	1400	Aprilaire (Space-Gard)	401	—	FR1400U-108	FR1400U108
16"H X 25"W X 5"D	1400	Aprilaire (Space-Gard)	—	2400	FR1400U-108	FR1400U108
16"H X 25"W X 5"D	1400	Carrier	ACBCM1	—	FR1400U-108	FR1400U108
16"H X 25"W X 5"D	1400	Carrier	—	FILBBFTC0016	FR1400U-108	FR1400U108
16"H X 25"W X 5"D	1400	Carrier	—	FILCCFTC0016	FR1400U-108	FR1400U108
16"H X 25"W X 5"D	1400	Carrier	—	FILBBCAR0016	FR1400U-108	FR1400U108
16"H X 25"W X 5"D	1400	Carrier	—	FILCCAR0016	FR1400U-108	FR1400U108
16"H X 25"W X 5"D	1400	Honeywell	FC100A1029	—	FR1400U-108	FR1400U108
16"H X 25"W X 5"D	1400	Honeywell	FC100C1009	—	FR1400U-108	FR1400U108
16"H X 25"W X 5"D	1400	Honeywell	FC200E1029	—	FR1400U-108	FR1400U108
16"H X 25"W X 5"D	1400	Honeywell	—	F100F2002	FR1400U-108	FR1400U108
16"H X 25"W X 5"D	1400	Honeywell	—	F100F1012	FR1400U-108	FR1400U108
16"H X 25"W X 5"D	1400	Honeywell	—	F100B1016	FR1400U-108	FR1400U108
16"H X 25"W X 5"D	1400	Honeywell	—	F150E1026	FR1400U-108	FR1400U108
16"H X 25"W X 5"D	1400	Honeywell	—	F200E1029	FR1400U-108	FR1400U108
16"H X 25"W X 5"D	1400	Lennox	X0582	—	FR1400U-108	FR1400U108
16"H X 25"W X 5"D	1400	Lennox	X0583	—	FR1400U-108	FR1400U108
16"H X 25"W X 5"D	1400	Lennox	X0584	—	FR1400U-108	FR1400U108
16"H X 25"W X 5"D	1400	Lennox	—	BMAC-14C	FR1400U-108	FR1400U108
16"H X 25"W X 5"D	1400	Trion	255649-102	—	FR1400U-108	FR1400U108
16"H X 25"W X 5"D	1400	Trion	—	455602-119	FR1400U-108	FR1400U108
16"H X 25"W X 5"D	1400	White-Rodgers	FR1400U-108	—	FR1400U-108	FR1400U108
16"H X 25"W X 5"D	1400	White-Rodgers	—	ACM1400U-108	FR1400U-108	FR1400U108
16"H X 25"W X 5"D	1400	White-Rodgers	FR1400-100	—	FR1400U-108	FR1400U108
16"H X 25"W X 5"D	1400	White-Rodgers	—	ACM1400-101	FR1400U-108	FR1400U108
16"H X 25"W X 5"D	1400	White-Rodgers	—	ACB1400-101	FR1400U-108	FR1400U108
20"H X 25"W X 5"D	2000	Aprilaire (Space-Gard)	201	—	FR2000U-108	FR2000U108
20"H X 25"W X 5"D	2000	Aprilaire (Space-Gard)	—	2250	FR2000U-108	FR2000U108
20"H X 25"W X 5"D	2000	Carrier	ACBCM2	—	FR2000U-108	FR2000U108
20"H X 25"W X 5"D	2000	Carrier	—	FILBBFTC0020	FR2000U-108	FR2000U108
20"H X 25"W X 5"D	2000	Carrier	—	FILBBCAR0020	FR2000U-108	FR2000U108
20"H X 25"W X 5"D	2000	Carrier	—	FILCCFTC0020	FR2000U-108	FR2000U108
20"H X 25"W X 5"D	2000	Carrier	—	FILCCAR0020	FR2000U-108	FR2000U108
20"H X 25"W X 5"D	2000	Honeywell	FC100A1037	—	FR2000U-108	FR2000U108
20"H X 25"W X 5"D	2000	Honeywell	FC200E1037	—	FR2000U-108	FR2000U108
20"H X 25"W X 5"D	2000	Honeywell	—	F100F2010	FR2000U-108	FR2000U108
20"H X 25"W X 5"D	2000	Honeywell	—	F100F1038	FR2000U-108	FR2000U108
20"H X 25"W X 5"D	2000	Honeywell	—	F100B1024	FR2000U-108	FR2000U108
20"H X 25"W X 5"D	2000	Honeywell	—	F150E1034	FR2000U-108	FR2000U108
20"H X 25"W X 5"D	2000	Honeywell	—	F200E1037	FR2000U-108	FR2000U108
20"H X 25"W X 5"D	2000	Lennox	X0586	—	FR2000U-108	FR2000U108
20"H X 25"W X 5"D	2000	Lennox	X0587	—	FR2000U-108	FR2000U108
20"H X 25"W X 5"D	2000	Lennox	—	BMAC-20C	FR2000U-108	FR2000U108
20"H X 25"W X 5"D	2000	Trion	255649-102	—	FR2000U-108	FR2000U108
20"H X 25"W X 5"D	2000	Trion	—	455602-019	FR2000U-108	FR2000U108
20"H X 25"W X 5"D	2000	White-Rodgers	FR2000U-108	—	FR2000U-108	FR2000U108
20"H X 25"W X 5"D	2000	White-Rodgers	FR2000U-110	—	FR2000U-108	FR2000U108
20"H X 25"W X 5"D	2000	White-Rodgers	—	ACM2000U-108	FR2000U-108	FR2000U108
20"H X 25"W X 5"D	2000	White-Rodgers	—	ACM2000U-110	FR2000U-108	FR2000U108
20"H X 25"W X 5"D	2000	White-Rodgers	FR2000-100	—	FR2000U-108	FR2000U108
20"H X 25"W X 5"D	2000	White-Rodgers	—	ACM2000-101	FR2000U-108	FR2000U108
20"H X 25"W X 5"D	2000	White-Rodgers	—	ACB2000-101	FR2000U-108	FR2000U108



47D01U-843

# Universal Heat Pump Defrost Control

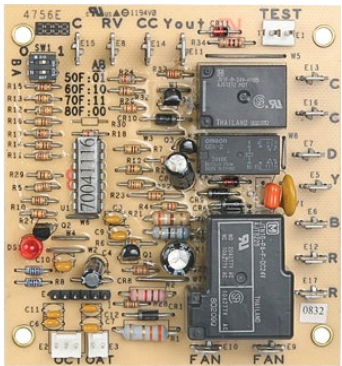
Universal upgrade for single stage heat pump systems with a PSC fan motor.

## Features

- Universal replacement for over 400 single stage part numbers
- Selectable demand or timed defrost modes
- Reversing valve can be energized in heat or cool (O/B)
- One-button configuration to any OEM system
- Integrated outdoor thermostat eliminates need for additional components
- Includes outdoor sensors
- Test mode to verify installation and trouble shoot
- Access setup and diagnostic menus from any orientation
- Brownout and short-cycle protection plus hi/low pressure inputs

### Heat Pump Defrost Control

Replacement type	Stages	Description	Input voltage	Line voltage	Outdoor condenser fan motor	Mounting	Operating temperature range	Dimensions	Model number	Item number
Universal	Single	Defrost Control	24 VAC, 50/60Hz	208/240 VAC	PSC	Tray	-40 to 150°F (-40 to 65°C)	1.75"H X 4.72"W X 5.75"D	47D01U-843	47D01U-843



47D40-801

# A/C, Heat Pump and Demand Defrost Controls

Direct OEM replacements for AC/heat pump and demand defrost controls.

## Features

- Direct drop-in replacements for Goodman and Rheem brands.

### A/C & Demand Defrost Controls

Direct OEM replacement	Stages	Description	Input voltage	Line voltage	Outdoor condenser fan motor	Mounting	Operating temperature range	Dimensions	Model number	Item number
Goodman	Two-Stage	AC or Heat Pump Control	24 VAC, 60Hz	240 VAC	PSC or ECM	Standoff	-40 to 175°F (-40 to 80°C)	3.69"H X 11.56"W X 6.86"D	49S25-707	49S25-707
Rheem	Single	Demand Defrost Control	24 VAC, 50 / 60Hz	208/240 VAC	PSC	Metal Standoff	-40 to 150°F (-40 to 65°C)	1.24"H X 3.38"W X 3.63"D	47D40-801	47D40-801
Rheem	Single	Demand Defrost Control	24 VAC, 50 / 60Hz	208/240 VAC	PSC or ECM	Plastic Standoff	-40 to 150°F (-40 to 65°C)	5.51"H X 3.50"W X 1.13"D	47D43-811	47D43-811



49M11-843

# SureSwitch Multi-Volt Universal Contactor

Universal electronic upgrade for mechanical compressor contactors with 5x contactor life and completely sealed to keep out ants and debris.

## Features

- Multi-volt coil replaces all common coil voltages
- 5x traditional contactor life
- Totally sealed switch keeps out ants, pests and debris
- Microprocessor control inhibits arcing that cause welding and pitting
- Line voltage brownout protection and short cycle timer provide compressor protection
- Heavy-duty lug connectors
- Zero chatter latching relay
- Tri-color LED displays
- 5-year limited warranty
- Four-hole mounting matches mechanical contactors
- Compressor test and cycle count by pushbutton

## Specifications

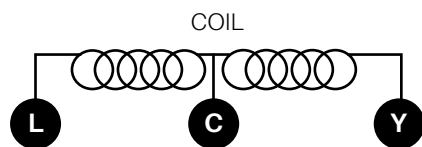
Line voltage input.....	120/208/240 VAC, 50/60 Hz
Control (coil) voltage.....	(Y-C) 24 VAC, 50/60 Hz
.....	(Line-C) 120/208/240VAC, 50/60 Hz
Full load amperes.....	40A
Locked rotor amperes.....	200A
Anti-short-cycle delay.....	0s or 180s (selectable) at 60 Hz, 0s or 216s (selectable) at 50 Hz
Compressor test.....	5s at 60 Hz, 6s at 50 Hz
Operating temperature range.....	-40° to 158°F (-40 to 70°C)
Coil terminals.....	1/4" male QC's accepting # 12-24 AWG wire
Dimensions.....	2.75"W X 2.38"H X 3.88"L
UL recognized to.....	UL60730-1

### SureSwitch Multi-Volt Contactor

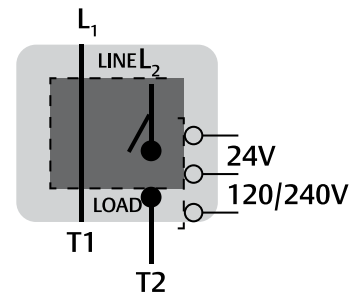
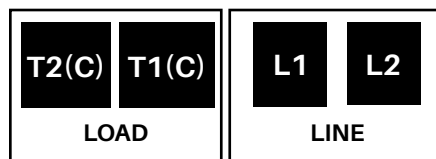
Coil	Line voltage input	Amp rating	Poles*	Model number	Item number
24/120/208/240 Vac	120/208/240 Vac	40 FLA, 200 LRA	1 or 1.5	49M11-843	49M11-843

\* 2 pole applications if local electrical codes are met

### Terminal designations:



### Lugs



### Coil details:

For voltage over 100 VAC: Connect line level control voltage to "Line", connect neutral or opposite leg to "Common."

For class 2 24VAC: Connect 24V control voltage to "Y", connect 24V ground to "Common."

### 1/4" Quick connect for accessories

- Hard Start
- Crank case heater
- Capacitor
- Fan Common

### Led flash codes

Slow Green	Standby
Solid Green	Normal
Fast Green	Delay
Green/Red	Low Line Voltage
Green/Yellow/Red	Test



94-388

# 94 Series 1.5 Pole Mechanical Contactors

Straight-through wiring, replaces 1-1/2 pole devices used primarily in residential central air conditioning.

## Features

- Replaces many contactors used by OEM's
- Universal style mounting bracket fits existing mounting holes
- Screw terminals and 1/4" quick connect terminals for easy installation

## Specifications

Approximate overall dimensions..... 2.50"H X 2.00"W X 3.38"D  
 Temperature range..... -40°F to 150°F  
 Mechanical / electrical life..... Conforms to UL and ARI specifications  
 Coil voltage / frequency / insulation ..... 24, 120 VAC / 50-60 Hz / Class B (130°C)  
 Termination ..... Screw and Double 1/4" Q.C.  
 Operate..... 85% - 110% of nominal coil voltage  
 Duty cycle..... Continuous  
 Weight (approximate)..... 7 oz  
 UR/CUR file number..... E310181 CE approved

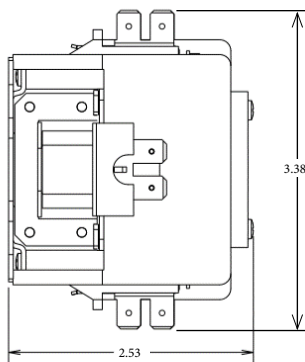
### 94 Series 1.5 Pole Mechanical Contactors - Coil data

Model	Res dc ohms	Current ma	Nominal va	Max. Inrush va	Model number	Item number
30 AMP	19.5	208	5	28	94-388	94 388S1
40 AMP	19.5	208	5	28	94-394	94 394S1
30 AMP	505	42	5	28	94-389	94 389S1
40 AMP	505	42	5	28	94-395	94 395S1

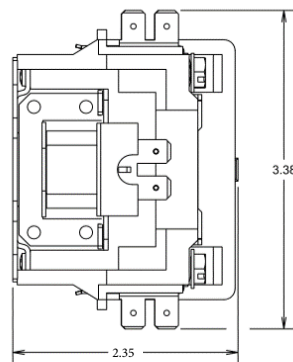
\* 30 amp models have no cover on top as in line drawing below  
 \*\* 40 amp models have cover on top as in picture above

### 94 Series 1.5 Pole Mechanical Contactors - Coil data

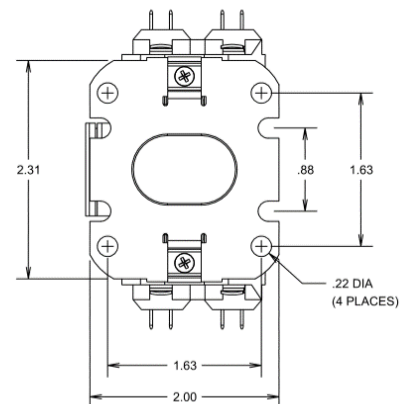
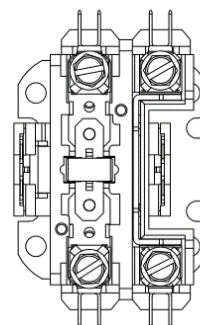
Voltage ac	Fla	Lra	Res	Model number
240/277	30	180	40	94-388 thru 94-389
480	30	125	40	94-388 thru 94-389
600	30	100	40	94-388 thru 94-389
240/277	40	240	50	94-394 thru 94-395
480	40	200	50	94-394 thru 94-395
600	40	160	50	94-394 thru 94-395

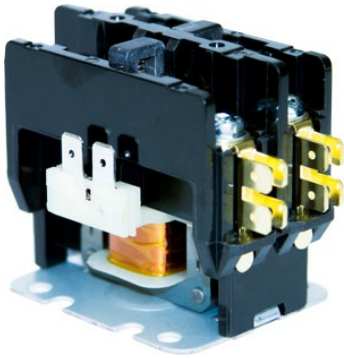


40 AMP MODEL (WITH COVER)



30 AMP MODEL (NO COVER)





94-244

# 90 Series 2 Pole Mechanical Contactors

Designed for air conditioning and heating equipment.

## Features

- Low VA coil for cooler operation and increased life
- Quiet operation
- Universal style mounting bracket fits existing mounting holes
- Double break contacts ensure positive make and break
- Screw terminals or lugs and quad 1/4" quick connects provided on all models for easy installation

## Specifications

Approximate overall dimensions..... 2.50"H X 2.00"W X 3.38"D  
 Temperature range..... -40°F to 150°F  
 Mechanical / electrical life..... Conforms to UL and ARI specifications  
 Coil voltage / frequency / insulation..... 24, 120, 208, 240 VAC / 50-60 Hz / Class B (130°C)  
 Termination..... Screw terminals or lugs and double 1/4" Q.C.  
 Operate..... 85% - 110% of nominal coil voltage  
 Duty cycle..... Continuous  
 Weight (approximate)..... 9.5 oz.  
 UR/CUR file number..... E310181  
 ..... CE Approved

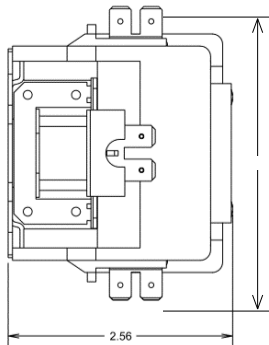
### 90 Series 2 Pole Mechanical Contactors - Coil data

Voltage ac	Model	Res dc ohms	Current ma	Nominal va	Max. Inrush va	Model number	Item number
24	30 AMP	11.5	270	6.5	30	90-244	90 244S1
24	40 AMP	11.5	270	6.5	30	90-247	90 247S1
120	30 AMP	295	54	6.5	30	90-245	90 245S1
120	40 AMP	295	54	6.5	30	90-248	90 248S1
208 / 240	30 AMP	995	27	6.5	30	90-246	90 246S1
208 / 240	40 AMP	995	27	6.5	30	90-249	90 249S1

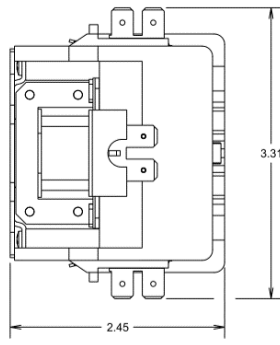
\* 30 amp models have no cover on top  
 \*\* 40 amp models have cover on top

### 90 Series 2 Pole Mechanical Contactors - Contact ratings

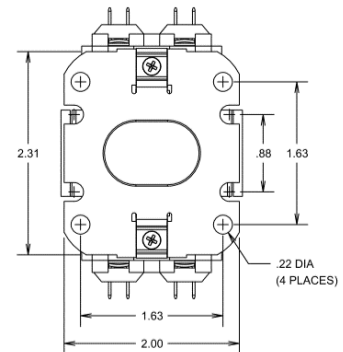
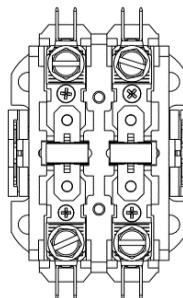
Voltage ac	I <sub>fla</sub>	I <sub>lra</sub>	Res	Model number
240 / 277	30	180	40	90-244 thru 90-246
480	30	125	40	90-244 thru 90-246
600	30	100	40	90-244 thru 90-246
240 / 277	40	240	50	90-247 thru 90-249
480	40	200	50	90-247 thru 90-249
600	40	160	50	90-247 thru 90-249



40 AMP MODEL (WITH COVER)



30 AMP MODEL (NO COVER)





90-163

# 90 Series 3 Pole Mechanical Contactors

Designed for air conditioning and heating equipment.

## Features

- Any position mounting
- Interchangeable mounting plate
- Low wattage coil
- Double break contacts ensure positive make and break

## Specifications

Approximate overall dimensions..... 3.00"H X 2.38"W X 3.75"D  
 Temperature range..... -40°F to 150°F  
 Mechanical / electrical life..... Conforms to UL and ARI specifications  
 Coil voltage / frequency / insulation..... 24, 120, 208, 240 VAC / 50-60 Hz / Class B (130°C)  
 Termination..... Screw terminals or lugs and double 1/4" Q.C.  
 Operate..... 85% - 110% of nominal coil voltage  
 Duty cycle..... Continuous  
 Weight (approximate)..... 16 oz.  
 UR/CUR file number..... E310181  
 ..... CE Approved

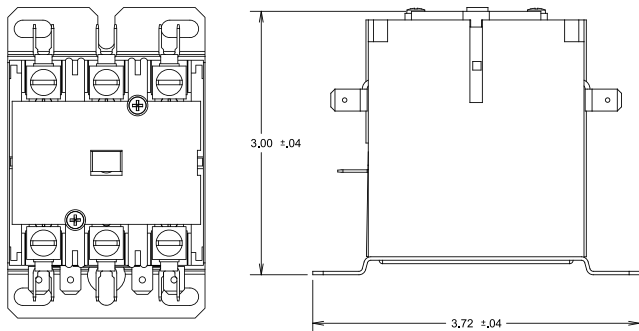
### 90 Series 3 Pole Mechanical Contactors - Coil data

Voltage ac	Model	Res dc ohms	Current ma	Nominal va	Max. Inrush va	Model number	Item number
24	30 AMP	7.0	208	5.0	60	90-163	90 163S1
24	40 AMP	7.0	208	5.0	60	90-170	90 170S1
120	30 AMP	175	42	5.0	60	90-164	90 164S1
120	40 AMP	175	42	5.0	60	90-171	90 171S1
208 / 240	30 AMP	665	21	5.0	60	90-165	90 165S1
208 / 240	40 AMP	665	21	5.0	60	90-172	90 172S1

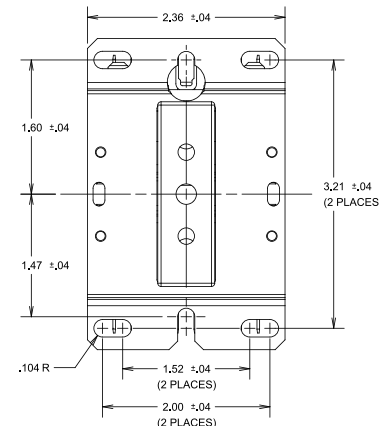
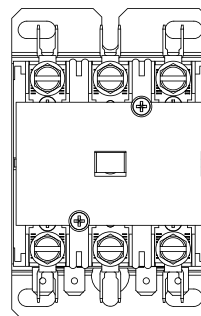
### 90 Series 2 Pole Mechanical Contactors - Contact ratings

Voltage ac	Fla	Lra	Res	Type
240 / 277	30	180	40	90-163 thru 90-165
480	30	150	40	90-163 thru 90-165
600	30	120	40	90-163 thru 90-165
240 / 277	40	240	50	90-170 thru 90-172
480	40	200	50	90-170 thru 90-172
600	40	160	50	90-170 thru 90-172

40 AMP with lugs



30 AMP with Screw terminals





1F51N-619

# Evaporative Cooling Thermostat and Control

Functions as a switching device for the thermostat to provide an even level of cooling plus a choice of high and low speed control of the fan on evaporative coolers

## Features

- Grey plastic case is lightweight, weather-resistant and meets all code requirements
- Fully automatic, system designed with a fan delay (approximately 60 seconds) to pre-wet the cooler pads before the fan start
- Separate fan and pump relays. High or low fan speed selection
- Relay panel is removable from enclosure to facilitate field wiring
- Integral transformer 120/240 VAC to 24 VAC 60 Hz

## Specifications

1F51N-619 Electrical rating ..... 24 VAC (30 VAC maximum) fixed anticipator  
 1F51N-619 Dimensions ..... 3.25"H X 4.50"W X 1.63"D  
 8A18Z-2 Dimensions ..... 8.00"H X 6.00"W X 3.00"D

### Evaporative Cooling Thermostat and Control

Package consists of:	Model number	Item number
1F51N-619 / 8A18Z-2	21D28-6	21D28 006

### Evaporative Cooling Thermostat

Color	Range	Differential	System switch position	Fan switch position	Model number	Item number
Classic White	Scale 1-2-3-4-5 (55 to 95°F) No thermometer	1°F	Off, Cool, Vent	Hi, Lo	1F51N-619	1F51N-619

### Evaporative Cooling Control

Input voltage	Combined relay loads full load	Combined relay loads locked rotor	Pump relay full load	Pump relay locked rotor	Fan relay full load	Fan relay locked rotor	Agency	Model number	Item number
120 VAC, 240 VAC	16.0A, 8.0A	96.0A, 48.0A	10.0A, 5.0A	60.0A, 30.0A	12.0A, 6.0A	72.0A, 36.0A	U.L. Listed	8A18Z-2	08A18Z002S1

# Expansion valves quick selection guide

Tonnage									Valve series	Port		Internal check (optional)	Field serviceable
R-410A	R-22 / R-407A / R-407C	R-134A	R-404A / R-502 / R-507	R-448A / R-449A	R-513A / R-450A	R-32	R-454B / R-452B	R-290		Conventional	Balanced		
1 to 5	1/4 to 5	1/8 to 3	1/8 to 3	1/5 to 5.5	1/8 to 3	—	—	1/5 to 1.5	A	√		√	
1/2 to 15	—	—	—	—	—	0.9 to 22	0.6 to 16	—	NXT		√	√	
1.5 to 5	1.5 to 5	—	—	—	—	—	—	—	TXV Connect Kit		√	√	
—	1/4 to 20	1/4 to 14	1/8 to 10	1/4 to 8.5	1/5 to 11.5	—	—	1/4 to 5.5	HF		√		√
—	1/2 to 20	1/3 to 12	1/3 to 14	—	—	—	—	—	TI	√			
—	1/2 to 12	1/4 to 9	1/4 to 8	—	—	—	—	—	TCL	√			√
—	11 to 14	9 to 11	7 to 9	—	—	—	—	—	TJL	√			√
—	14 to 18	11 to 13	9 to 12	—	—	—	—	—	TJR	√			√
—	22 to 45	16 to 31	14 to 27	—	—	—	—	—	TER		√		√
—	55	45	37	—	—	—	—	—	TIR		√		√
—	55 to 85	45 to 68	37 to 60	—	—	—	—	—	THR		√		√
—	100	68	60	—	—	—	—	—	TMR		√		√
—	10 to 40	22 to 30	14 to 20	—	—	—	—	—	TRAE+		√		√
—	50 to 70	40	35	—	—	—	—	—	TRAE		√		
20 to 50	7 to 40	4 to 24	—	—	3-3/4 to 21	12 to 68	—	—	TX7		√		
—	1/2 to 5.5	1/3 to 4	1/3 to 3.5	—	—	—	—	—	ACP	√			
—	3/4 to 30	—	3/4 to 29	—	—	—	—	—	ZZ	√			√
—	1/2 to 12	1/4 to 7.5	1/4 to 8	—	—	—	—	—	LA / LCL	√			√
1/5 to 292	1/2 to 250	1/3 to 193	1/3 to 174	—	—	—	—	—	EX	Linear Flow			
0.2 to 4.5	0.1 to 3.8	0.1 to 2.8	0.1 to 2.5	0.1 to 3.6	0.1 to 2.9	—	—	—	PM (PWM)	Pulse Width Modulated			



# NXT Series Thermostatic Expansion Valves

The Copeland NXT Series is a balanced ported valve designed for high efficiency R-410A and R-454B air conditioning and heat pump applications. NXT Series valves operate over a wide range of conditions and applications offering excellent performance, superior reliability, and unparalleled valve life.

## Features

- Precision superheat control optimized for R-410A systems and newly created A2L refrigerants, including R-454B.
- Stainless steel sensing bulb and capillary tubing prevents corrosion and provides durability.
- Enhanced power element design offers extended life.
- Laser etched identification markings for permanent legibility.
- Hermetic leak-free construction of all joints.
- Internal check models provide bi-directional capability for heat pump applications.
- Balanced port construction.
- External equalizer is standard, other configurations available.
- Optional screens on ODF inlet connections.
- Available in adjustable or non-adjustable superheat.

## Specifications

Maximum working pressure.....700 psig (48 bar)  
 R-410A operating range.....-20°F to +50°F (-29° to 10°C)  
 UR/CUR file number..... SA5312  
 Canadian CRN.....0C20308.5C

**Model number nomenclature - Example: NAE 3ZAA-17**

Series	Body type	Equalizer	Capacity	System refrigerant code	Charge code	Sequential identifier	Customer special	Pack type
N	A	E	3	Z	AA	-17		
NXT Series Balanced Port	A = Adjustable Superheat, With Check, Straight-Thru B = Adjustable Superheat, No Check, Straight-Thru C = Non-Adjustable Superheat, With Check, Straight-Thru D = Non-Adjustable Superheat, No Check, Straight-Thru	E = External Equalizer	Nominal Rating in Tons	Z = R-410A U = R-454B	AA = Wide Range	-01 Thru -999	G = Cust. Special  (Omit for Standard)	B1 = Bulk Pack  (Omit for Individual Pack)

## NXT Series Thermostatic Expansion Valves (body style straight thru)

System refrigerant code	Capacity (nominal tonnage)	Charge code	Inlet X outlet connection	Adjustable superheat	Internal check	Equalizer	Bleed	Cap length	Model number	Item number
Z(R-410A)	1/2	AA (Wide Range)	3/8" X 3/8" ODF	Yes	No	30" With Angle Cut	15%	30 in.	NBE 1/2ZAA-05	091065
	1/2	AA (Wide Range)	3/8" X 1/2" ODF	Yes	No	1/4" ODF	No	30 in.	NBE 1/2ZAA-06	091066
	1	AA (Wide Range)	Chatleff	Yes	Yes	5 Ft.*	No	60 in.	NAE 1ZAA-07	091002
	1	AA (Wide Range)	3/8" X 1/2" ODF	Yes	Yes	1/4" ODF	15%	60 in.	NAE 1ZAA-08	091001
	1	AA (Wide Range)	3/8" X 1/2" ODF	Yes	No	1/4" ODF	15%	60 in.	NBE 1ZAA-09	091005
	1	AA (Wide Range)	3/8" X 1/2" ODF	Yes	Yes	1/4" ODF	No	60 in.	NAE 1ZAA-05	091000
	1	AA (Wide Range)	3/8" X 1/2" ODF	Yes	No	1/4" ODF	No	60 in.	NBE 1ZAA-08	091004
	1-1/2	AA (Wide Range)	Chatleff	Yes	Yes	5 Ft.*	No	60 in.	NAE 1-1/2ZAA-11	091008
	1-1/2	AA (Wide Range)	3/8" X 1/2" ODF	Yes	Yes	1/4" ODF	15%	60 in.	NAE 1-1/2ZAA-10	091007
	1-1/2	AA (Wide Range)	3/8" X 1/2" ODF	Yes	No	1/4" ODF	15%	60 in.	NBE 1-1/2ZAA-13	091011
	1-1/2	AA (Wide Range)	3/8" X 1/2" ODF	Yes	Yes	1/4" ODF	No	60 in.	NAE 1-1/2ZAA-09	091006
	1-1/2	AA (Wide Range)	3/8" X 1/2" ODF	Yes	No	1/4" ODF	No	60 in.	NBE 1-1/2ZAA-12	091010
	2	AA (Wide Range)	Chatleff	Yes	Yes	5 Ft.*	No	60 in.	NAE 2ZAA-12	091014
	2	AA (Wide Range)	3/8" X 1/2" ODF	Yes	Yes	1/4" ODF	15%	60 in.	NAE 2ZAA-11	091013

System refrigerant code	Capacity (nominal tonnage)	Charge code	Inlet X outlet connection	Adjustable superheat	Internal check	Equalizer	Bleed	Cap length	Model number	Item number
Z(R-410A)	2	AA (Wide Range)	3/8" X 1/2" ODF	Yes	No	1/4" ODF	15%	60 In.	NBE 2ZAA-05	091017
	2	AA (Wide Range)	3/8" X 1/2" ODF	Yes	Yes	1/4" ODF	No	60 In.	NAE 2ZAA-10	091012
	2	AA (Wide Range)	3/8" X 1/2" ODF	Yes	No	1/4" ODF	No	60 In.	NBE 2ZAA-04	091016
	3	AA (Wide Range)	Chatteff	Yes	Yes	5 Ft.*	No	60 In.	NAE 3ZAA-17	091020
	3	AA (Wide Range)	3/8" X 1/2" ODF	Yes	Yes	1/4" ODF	15%	60 In.	NAE 3ZAA-16	091019
	3	AA (Wide Range)	3/8" X 1/2" ODF	Yes	No	1/4" ODF	15%	60 In.	NBE 3ZAA-12	091023
	3	AA (Wide Range)	3/8" X 1/2" ODF	Yes	Yes	1/4" ODF	No	60 In.	NAE 3ZAA-15	091018
	3	AA (Wide Range)	3/8" X 1/2" ODF	Yes	No	1/4" ODF	No	60 In.	NBE 3ZAA-11	091022
	4	AA (Wide Range)	Chatteff	Yes	Yes	5 Ft.*	No	60 In.	NAE 4ZAA-19	091026
	4	AA (Wide Range)	3/8" X 1/2" ODF	Yes	Yes	1/4" ODF	15%	60 In.	NAE 4ZAA-18	091025
	4	AA (Wide Range)	3/8" X 1/2" ODF	Yes	No	1/4" ODF	15%	60 In.	NBE 4ZAA-09	091029
	4	AA (Wide Range)	3/8" X 1/2" ODF	Yes	Yes	1/4" ODF	No	60 In.	NAE 4ZAA-17	091024
	4	AA (Wide Range)	3/8" X 1/2" ODF	Yes	No	1/4" ODF	No	60 In.	NBE 4ZAA-08	091028
	5	AA (Wide Range)	Chatteff	Yes	Yes	5 Ft.*	No	60 In.	NAE 5ZAA-31	091032
	5	AA (Wide Range)	3/8" X 1/2" ODF	Yes	Yes	1/4" ODF	No	60 In.	NAE 5ZAA-33	091063
	5	AA (Wide Range)	1/2" X 5/8" ODF	Yes	Yes	1/4" ODF	15%	60 In.	NAE 5ZAA-30	091031
	5	AA (Wide Range)	1/2" X 5/8" ODF	Yes	No	1/4" ODF	15%	60 In.	NBE 5ZAA-12	091035
	5	AA (Wide Range)	1/2" X 5/8" ODF	Yes	No	1/4" ODF	No	60 In.	NBE 5ZAA-11	091034
	6	AA (Wide Range)	Chatteff	Yes	Yes	5 Ft.*	No	60 In.	NAE 6ZAA-07	091038
	6	AA (Wide Range)	1/2" X 5/8" ODF	Yes	Yes	1/4" ODF	15%	60 In.	NAE 6ZAA-06	091037
	6	AA (Wide Range)	1/2" X 5/8" ODF	Yes	No	1/4" ODF	15%	60 In.	NBE 6ZAA-09	091041
	6	AA (Wide Range)	1/2" X 5/8" ODF	Yes	Yes	1/4" ODF	No	60 In.	NAE 6ZAA-05	091036
	6	AA (Wide Range)	1/2" X 5/8" ODF	Yes	No	1/4" ODF	No	60 In.	NBE 6ZAA-08	091040
	7	AA (Wide Range)	Chatteff	Yes	Yes	5 Ft.*	No	60 In.	NAE 7ZAA-09	091044
	7	AA (Wide Range)	5/8" X 7/8" ODF	Yes	Yes	1/4" ODF	15%	60 In.	NAE 7ZAA-08	091043
	7	AA (Wide Range)	5/8" X 7/8" ODF	Yes	No	1/4" ODF	15%	60 In.	NBE 7ZAA-08	091047
	7	AA (Wide Range)	5/8" X 7/8" ODF	Yes	Yes	1/8" Cap	No	60 In.	NAE 7ZAA-10	091045
	7	AA (Wide Range)	5/8" X 7/8" ODF	Yes	No	1/4" ODF	No	60 In.	NBE 7ZAA-07	091046
	8	AA (Wide Range)	5/8" X 7/8" ODF	Yes	No	1/4" ODF	15%	60 In.	NBE 8ZAA-03	091049
	8	AA (Wide Range)	5/8" X 7/8" ODF	Yes	No	1/4" ODF	No	60 In.	NBE 8ZAA-02	091048
10	AA (Wide Range)	5/8" X 7/8" ODF	Yes	No	1/4" ODF	15%	60 In.	NBE 10ZAA-04	091051	
10	AA (Wide Range)	5/8" X 7/8" ODF	Yes	No	1/4" ODF	No	60 In.	NBE 10ZAA-03	091050	
12	AA (Wide Range)	1/2" X 5/8" ODF	Yes	No	1/4" ODF	No	60 In.	NBE 12ZAA-09	091060	
12	AA (Wide Range)	5/8" X 7/8" ODF	Yes	No	1/4" ODF	15%	60 In.	NBE 12ZAA-06	091053	
12	AA (Wide Range)	5/8" X 7/8" ODF	Yes	No	1/4" ODF	No	60 In.	NBE 12ZAA-05	091052	
12	AA (Wide Range)	5/8" X 1-1/8" ODF	Yes	No	1/4" ODF	No	60 In.	NBE 12ZAA-07	091054	
12	AA (Wide Range)	7/8" X 1-1/8" ODF	Yes	No	1/4" ODF	No	60 In.	NBE 12ZAA-08	091055	
15	AA (Wide Range)	5/8" X 7/8" ODF	Yes	No	1/4" ODF	No	60 In.	NBE 15ZAA-06	091056	
15	AA (Wide Range)	5/8" X 1-1/8" ODF	Yes	No	1/4" ODF	No	60 In.	NBE 15ZAA-08	091058	
15	AA (Wide Range)	7/8" X 1-1/8" ODF	Yes	No	1/4" ODF	No	60 In.	NBE 15ZAA-09	091059	
U (R-454B)	1	AA (Wide Range)	3/8" X 1/2" ODF	Yes	No	1/4" ODF	15%	60 In.	NBE 1UAA-01	600297
	1	AA (Wide Range)	3/8" X 1/2" ODF	Yes	Yes	1/4" ODF	No	30 In.	NAE 1UAA-01	600376
	1-1/2	AA (Wide Range)	3/8" X 1/2" ODF	Yes	No	1/4" ODF	15%	60 In.	NBE 1-1/2UAA-01	600298
	1-1/2	AA (Wide Range)	3/8" X 1/2" ODF	Yes	Yes	1/4" ODF	No	30 In.	NAE 1-1/2UAA-06	600377
	2	AA (Wide Range)	3/8" X 1/2" ODF	Yes	No	1/4" ODF	15%	60 In.	NBE 2UAA-01	600299
	2	AA (Wide Range)	3/8" X 1/2" ODF	Yes	Yes	1/4" ODF	15%	30 In.	NAE 2UAA-03	600381
	2	AA (Wide Range)	3/8" X 1/2" ODF	Yes	Yes	1/4" ODF	No	30 In.	NAE 2UAA-02	600378
	3	AA (Wide Range)	3/8" X 1/2" ODF	Yes	No	1/4" ODF	15%	60 In.	NBE 3UAA-01	600300
	3	AA (Wide Range)	3/8" X 1/2" ODF	Yes	Yes	1/4" ODF	15%	30 In.	NAE 3UAA-02	600382
	3	AA (Wide Range)	3/8" X 1/2" ODF	Yes	Yes	1/4" ODF	No	30 In.	NAE 3UAA-01	600379
	4	AA (Wide Range)	3/8" X 1/2" ODF	Yes	No	1/4" ODF	15%	60 In.	NBE 4UAA-01	600301
	4	AA (Wide Range)	3/8" X 1/2" ODF	Yes	Yes	1/4" ODF	15%	30 In.	NAE 4UAA-03	600383
	4	AA (Wide Range)	1/2" X 5/8" ODF	Yes	Yes	1/4" ODF	No	30 In.	NAE 4UAA-02	600380
	5	AA (Wide Range)	1/2" X 5/8" ODF	Yes	No	1/4" ODF	15%	60 In.	NBE 5UAA-03	600313
	5	AA (Wide Range)	3/8" X 1/2" ODF	Yes	Yes	1/4" ODF	15%	30 In.	NAE 5UAA-01	600384
6	AA (Wide Range)	1/2" X 5/8" ODF	Yes	No	1/4" ODF	15%	60 In.	NBE 6UAA-01	600302	
7	AA (Wide Range)	5/8" X 7/8" ODF	Yes	No	1/4" ODF	15%	60 In.	NBE 7UAA-01	600303	
8	AA (Wide Range)	5/8" X 7/8" ODF	Yes	No	1/4" ODF	15%	60 In.	NBE 8UAA-02	600314	
10	AA (Wide Range)	5/8" X 7/8" ODF	Yes	No	1/4" ODF	No	60 In.	NBE 10UAA-01	600316	

\* External equalizer has a stainless steel tube and copper flare with 1/4" SAE flare nut



# NXT-R Series Thermostatic Expansion Valves

Get precise control and reliable performance with our NXT-R series, combining the compact size of the A Series and the superheat control of the B Series, all built with the high-quality and reliability standards of NXT Series thermostatic expansion valves.

## Features

- Leak-free joints - laser welded brass and stainless steel
- Fractional tonnages with compact size for limited spaces
- Precision superheat control for many refrigerants - including A1, A2L, and A3
- Stainless steel power element, sensing bulb and capillary tubing prevent corrosion, providing maximum durability
- Laser etched identification markings for permanent legibility
- Balanced port construction
- Bleed port provides system equalization during off-cycle for low-starting torque compressors
- Optional inlet screens
- Available in adjustable or non-adjustable superheat
- Available with either External or Internal equalizer configuration

## Specifications

Maximum working pressure ..... 700 psig (48 bar)  
 UR/CUR file number.....SA5312

### Model number nomenclature - Example: NAE 3SZ-17

Series	Body type	Equalizer	Capacity	System refig. Code	Charge code	Seq. Id	Cust. Spec.	Pack type
n	A	E	3	S	Z	-17		
NXT-R Series Balanced Port	A = Adj. Superheat, Check, Straight B = Adj. Superheat, No Check, Straight C = Non-Adj. Superheat, Check, Straight D = Non-Adj. Superheat, No Check, Straight	E = Ext. Equalizer	Nom. Rating (Tons)	B = R-448A/R-449A/R-452A D = R-450A/R-513A H = R-22/R-407A M = R-134a S = R-404A/R-407H T = R-290	A = Medium & Low Temp. AA = Wide Range C = Medium Temp. CA = Heat Pump W(MOP) = Press. Limiting Z = Low Temp.	-01 Thru -999	G = Cust. Spec. (Omit for Std.)	B1 = Bulk Pack (Omit for Indiv. Pack)

NXT-R Series Thermostatic Expansion Valves (body style: straight through)

Refrigerant	Capacity (nominal tonnage)	Charge code	Inlet x outlet connection	Adjustable superheat	Internal check	Equalizer	Bleed	Cap length (inches)	Model number	Item number
B (R-448A/R-449A/R-452A)	1/5	A (Medium & Low Temp)	3/8" ODF X 1/2" ODF	YES	NO	External	NO	30	NBE 1/5BA-01	100069
	1/4	A (Medium & Low Temp)	1/4" ODF X 3/8" ODF	YES	NO	Internal	NO	30	NB 1/4BA-02	100071
	1/4	A (Medium & Low Temp)	3/8" ODF X 1/2" ODF	YES	NO	Internal	NO	30	NB 1/4BA-01	100070
	1/2	A (Medium & Low Temp)	1/4" ODF X 3/8" ODF	YES	NO	Internal	NO	30	NB 1/2BA-01	100073
	1/2	A (Medium & Low Temp)	3/8" ODF X 1/2" ODF	YES	NO	External	NO	30	NBE 1/2BA-02	100075
	1/2	A (Medium & Low Temp)	3/8" ODF X 1/2" ODF	YES	NO	Internal	NO	30	NB 1/2BA-02	100168
	1	A (Medium & Low Temp)	1/2" ODF X 5/8" ODF	YES	NO	External	NO	30	NBE 1BA-03	100079
	1	A (Medium & Low Temp)	3/8" ODF X 1/2" ODF	YES	NO	Internal	NO	30	NB 1BA-01	100076
	1	A (Medium & Low Temp)	3/8" ODF X 1/2" ODF	YES	NO	External	NO	30	NBE 1BA-02	100078
	1-1/2	A (Medium & Low Temp)	1/2" ODF X 5/8" ODF	YES	NO	External	NO	30	NBE 1-1/2BA-02	100080
	1-1/2	A (Medium & Low Temp)	3/8" ODF X 1/2" ODF	YES	NO	External	NO	30	NBE 1-1/2BA-03	100081
	2	A (Medium & Low Temp)	5/8" ODF X 7/8" ODF	YES	NO	External	NO	30	NBE 2BA-04	100086
	2	A (Medium & Low Temp)	3/8" ODF X 1/2" ODF	YES	NO	External	NO	30	NBE 2BA-02	100083
	2-1/2	A (Medium & Low Temp)	3/8" ODF X 1/2" ODF	YES	NO	External	NO	30	NBE 2-1/2BA-01	100087
	3-1/2	A (Medium & Low Temp)	3/8" ODF X 1/2" ODF	YES	NO	External	NO	30	NBE 3-1/2BA-02	100090
	4	A (Medium & Low Temp)	1/2" ODF X 5/8" ODF	YES	NO	External	NO	30	NBE 4BA-01	100094
5-1/2	A (Medium & Low Temp)	1/2" ODF X 5/8" ODF	YES	NO	External	NO	30	NBE 5-1/2BA-02	100097	
D (R-450A/R-513A)	1/8	A (Medium & Low Temp)	3/8" ODF X 1/2" ODF	YES	NO	Internal	NO	30	NB 1/8DA-02	100176
	1/8	A (Medium & Low Temp)	3/8" ODF X 1/2" ODF	YES	NO	External	NO	30	NBE 1/8DA-01	100181
	1/5	A (Medium & Low Temp)	1/4" ODF X 3/8" ODF	YES	NO	Internal	NO	30	NB 1/5DA-03	100191
	1/5	A (Medium & Low Temp)	3/8" ODF X 1/2" ODF	YES	NO	External	NO	30	NBE 1/5DA-02	100182
	1/5	A (Medium & Low Temp)	3/8" ODF X 1/2" ODF	YES	NO	Internal	NO	30	NB 1/5DA-02	100177
	1/4	A (Medium & Low Temp)	3/8" ODF X 1/2" ODF	YES	NO	Internal	NO	30	NB 1/4DA-02	100178
	1/4	A (Medium & Low Temp)	3/8" ODF X 1/2" ODF	YES	NO	External	NO	30	NBE 1/4DA-01	100183
	1/2	A (Medium & Low Temp)	3/8" ODF X 1/2" ODF	YES	NO	Internal	NO	30	NB 1/2DA-01	100179
	1/2	A (Medium & Low Temp)	3/8" ODF X 1/2" ODF	YES	NO	External	NO	30	NBE 1/2DA-01	100184
	3/4	A (Medium & Low Temp)	3/8" ODF X 1/2" ODF	YES	NO	Internal	NO	30	NB 3/4DA-01	100180
	3/4	A (Medium & Low Temp)	3/8" ODF X 1/2" ODF	YES	NO	External	NO	30	NBE 3/4DA-01	100185
	1	A (Medium & Low Temp)	3/8" ODF X 1/2" ODF	YES	NO	External	NO	30	NBE 1DA-01	100186
	1-1/2	A (Medium & Low Temp)	3/8" ODF X 1/2" ODF	YES	NO	External	NO	30	NBE 1-1/2DA-01	100187
	2	A (Medium & Low Temp)	3/8" ODF X 1/2" ODF	YES	NO	External	NO	30	NBE 2DA-01	100188
	2-1/2	A (Medium & Low Temp)	3/8" ODF X 1/2" ODF	YES	NO	External	NO	30	NBE 2-1/2DA-01	100189
	3	A (Medium & Low Temp)	3/8" ODF X 1/2" ODF	YES	NO	External	NO	30	NBE 3DA-01	100190

Refrigerant	Capacity (nominal tonnage)	Charge code	Inlet x outlet connection	Adjustable superheat	Internal check	Equalizer	Bleed	Cap length (inches)	Model number	Item number
H (R-22/R-407A)	1/4	C (Medium Temp)	1/4" ODF X 1/2" ODF	YES	NO	Internal	NO	60	NB 1/4HC-01	100208
	1/4	C (Medium Temp)	1/4" ODF X 3/8" ODF	YES	NO	Internal	NO	60	NB 1/4HC-02	100209
	1/2	CA (Heat Pump)	3/8" ODF X 1/2" ODF	YES	NO	External	15%	30	NBE 1/2HCA-01	100038
	1/2	C (Medium Temp)	3/8" SAE X 1/2" SAE	YES	NO	External	NO	60	NBE 1/2HC-02	100211
	1/2	C (Medium Temp)	3/8" ODF X 1/2" ODF	YES	NO	External	NO	60	NBE 1/2HC-01	100215
	1	CA (Heat Pump)	3/8" ODF X 1/2" ODF	YES	YES	External	NO	30	NAE 1HCA-09	100105
	1	CA (Heat Pump)	3/8" ODF X 1/2" ODF	YES	NO	External	15%	30	NBE 1HCA-03	100145
	1	C (Medium Temp)	3/8" SAE X 1/2" SAE	YES	NO	External	NO	60	NBE 1HC-03	100129
	1	C (Medium Temp)	3/8" ODF X 1/2" ODF	YES	NO	External	NO	60	NBE 1HC-02	100157
	1-1/2	CA (Heat Pump)	3/8" ODF X 1/2" ODF	YES	NO	External	15%	30	NBE 1-1/2HCA-04	100099
	2	CA (Heat Pump)	3/8" ODF X 1/2" ODF	YES	NO	External	15%	60	NBE 2HCA-02	100026
	2	CA (Heat Pump)	3/8" ODF X 1/2" ODF	YES	YES	External	NO	30	NAE 2HCA-05	100104
	2	CA (Heat Pump)	3/8" ODF X 1/2" ODF	YES	YES	External	NO	60	NAE 2HCA-06	100164
	2	C (Medium Temp)	3/8" SAE X 1/2" SAE	YES	NO	External	NO	60	NBE 2HC-01	100131
	2-1/2	CA (Heat Pump)	3/8" ODF X 1/2" ODF	YES	NO	External	NO	30	NBE 2-1/2HCA-03	100137
	2-1/2	CA (Heat Pump)	3/8" ODF X 1/2" ODF	YES	NO	External	15%	60	NBE 2-1/2HCA-02	100027
	2-1/2	AA (Wide Range)	3/8" ODF X 1/2" ODF	YES	NO	External	NO	30	NBE 2-1/2HAA-01	100102
	2-1/2	AA (Wide Range)	CHATLEFF X CHATLEFF	YES	YES	External	NO	30	NAE 2-1/2HAA-01	100115
	2-1/2	AA (Wide Range)	3/8" ODF X 1/2" ODF	YES	YES	External	NO	30	NAE 2-1/2HAA-02	100149
	3	CA (Heat Pump)	3/8" ODF X 1/2" ODF	YES	NO	External	NO	30	NBE 3HCA-05	100138
	3	CA (Heat Pump)	3/8" ODF X 1/2" ODF	YES	YES	External	NO	60	NAE 3HCA-05	100161
	3	CA (Heat Pump)	3/8" ODF X 1/2" ODF	YES	YES	External	15%	60	NAE 3HCA-06	100163
	3	C (Medium Temp)	3/8" SAE X 1/2" SAE	YES	NO	External	NO	60	NBE 3HC-01	100123
	4	CA (Heat Pump)	3/8" ODF X 1/2" ODF	YES	NO	External	15%	60	NBE 4HCA-01	100002
	4	CA (Heat Pump)	3/8" ODF X 1/2" ODF	YES	NO	External	NO	30	NBE 4HCA-04	100118
	4	CA (Heat Pump)	1/2" ODF X 1/2" ODF	YES	NO	External	15%	60	NBE 4HCA-05	100141
	4	CA (Heat Pump)	3/8" ODF X 1/2" ODF	YES	YES	External	NO	60	NAE 4HCA-03	100162
	5	CA (Heat Pump)	1/2" ODF X 5/8" ODF	YES	NO	External	NO	60	NBE 5HCA-03	100140
	5	CA (Heat Pump)	3/8" ODF X 5/8" ODF	YES	YES	External	NO	30	NAE 5HCA-04	100165
	5	CA (Heat Pump)	3/8" ODF X 1/2" ODF	YES	NO	External	NO	60	NBE 5HCA-04	100146
	5	CA (Heat Pump)	3/8" ODF X 1/2" ODF	YES	NO	External	15%	60	NBE 5HCA-01	100029
	5	CA (Heat Pump)	CHATLEFF X CHATLEFF	YES	YES	External	NO	30	NAE 5HCA-03	100037
5	C (Medium Temp)	3/8" SAE X 1/2" SAE	YES	NO	External	NO	60	NBE 5HC-03	100124	
6	CA (Heat Pump)	3/8" ODF X 1/2" ODF	YES	NO	External	15%	30	NBE 6HCA-01	100148	
8	CA (Heat Pump)	1/2" ODF X 7/8" ODF	YES	NO	External	NO	60	NBE 8HCA-01	100034	

Refrigerant	Capacity (nominal tonnage)	Charge code	Inlet x outlet connection	Adjustable superheat	Internal check	Equalizer	Bleed	Cap length (inches)	Model number	Item number
M (R-134A)	1/8	C (Medium Temp)	1/4" ODF X 3/8" ODF	YES	NO	Internal	NO	30	NB 1/8MC-03	100256
	1/4	C (Medium Temp)	1/4" ODF X 1/2" ODF	YES	NO	Internal	NO	60	NB 1/4MC-06	100261
	1/4	C (Medium Temp)	1/4" ODF X 3/8" ODF	YES	NO	External	NO	30	NB 1/4MC-07	100262
	1/4	C (Medium Temp)	1/4" ODF X 3/8" ODF	YES	NO	Internal	NO	30	NB 1/4MC-04	100259
	1/2	C (Medium Temp)	1/4" ODF X 1/2" ODF	YES	NO	Internal	NO	60	NB 1/2MC-03	100263
	1/2	C (Medium Temp)	1/4" ODF X 1/2" ODF	YES	NO	External	NO	60	NBE 1/2MC-04	100264
	1	C (Medium Temp)	3/8" ODF X 1/2" ODF	YES	NO	External	NO	60	NBE 1MC-02	100266
	1	C (Medium Temp)	3/8" ODF X 1/2" ODF	YES	NO	Internal	NO	30	NB 1MC-01	100267
	1	C (Medium Temp)	3/8" ODF X 3/8" ODF	YES	NO	External	NO	30	NBE 1MC-01	100265
	3	C (Medium Temp)	1/2" ODF X 5/8" ODF	YES	NO	External	NO	60	NBE 3MC-01	100268
	4	C (Medium Temp)	1/2" ODF X 5/8" ODF	YES	NO	External	NO	60	NBE 4MC-01	100269
S (R-404A/R-407H)	1/8	C (Medium Temp)	1/4" ODF X 3/8" ODF	YES	NO	Internal	NO	30	NB 1/8SC-02	100052
	1/4	C (Medium Temp)	1/4" ODF X 1/2" ODF	YES	NO	External	NO	30	NBE 1/4SC-02	100062
	1/4	Z (Low Temp)	1/4" ODF X 3/8" ODF	YES	NO	Internal	NO	60	NB 1/4SZ-06	100057
	1/4	C (Medium Temp)	1/4" ODF X 1/2" ODF	YES	NO	Internal	NO	30	NB 1/4SC-03	100055
	1/4	Z (Low Temp)	1/4" ODF X 1/2" ODF	YES	NO	External	NO	30	NBE 1/4SZ-01	100060
	1/4	Z (Low Temp)	1/4" ODF X 3/8" ODF	YES	NO	Internal	NO	30	NB 1/4SZ-04	100041
	1/4	W(MOP) (Press. Limiting)	1/4" ODF X 3/8" ODF	YES	NO	Internal	NO	60	NB 1/4SW45-01	100058
	1/4	C (Medium Temp)	1/4" ODF X 1/2" ODF	YES	NO	External	NO	30	NBE 1/4SC-01	100059
	1/2	C (Medium Temp)	1/4" ODF X 1/2" ODF	YES	NO	Internal	NO	60	NB 1/2SC-02	100226
	1/2	C (Medium Temp)	3/8" ODF X 1/2" ODF	YES	NO	External	NO	60	NBE 1/2SC-02	100229
	1/2	Z (Low Temp)	1/4" ODF X 1/2" ODF	YES	NO	External	NO	60	NBE 1/2SZ-03	100253
	1/2	Z (Low Temp)	1/4" ODF X 1/2" ODF	YES	NO	Internal	NO	60	NB 1/2SZ-06	100246
	1/2	C (Medium Temp)	1/4" ODF X 1/2" ODF	YES	NO	Internal	NO	30	NB 1/2SC-01	100223
	1/2	C (Medium Temp)	1/4" ODF X 1/2" ODF	YES	NO	External	NO	30	NBE 1/2SC-03	100234
	1/2	Z (Low Temp)	3/8" ODF X 1/2" ODF	YES	NO	External	NO	60	NBE 1/2SZ-02	100247
	1/2	W(MOP) (Press. Limiting)	1/4" ODF X 1/2" ODF	YES	NO	Internal	NO	60	NB 1/2SW45-01	100283
	3/4	C (Medium Temp)	3/8" ODF X 1/2" ODF	YES	NO	External	NO	60	NBE 3/4SC-01	100230
	3/4	C (Medium Temp)	3/8" ODF X 1/2" ODF	YES	NO	Internal	NO	60	NB 3/4SC-01	100232
	3/4	Z (Low Temp)	3/8" ODF X 1/2" ODF	YES	NO	Internal	NO	30	NB 3/4SZ-02	100244
	3/4	Z (Low Temp)	1/4" ODF X 1/2" ODF	YES	NO	External	NO	30	NBE 3/4SZ-01	100254
	1	C (Medium Temp)	3/8" ODF X 1/2" ODF	YES	NO	External	NO	60	NBE 1SC-01	100231
	1	C (Medium Temp)	3/8" ODF X 1/2" ODF	YES	NO	Internal	NO	60	NB 1SC-03	100233
	1	Z (Low Temp)	3/8" ODF X 1/2" ODF	YES	NO	Internal	NO	30	NB 1SZ-04	100245
	1-1/4	C (Medium Temp)	3/8" ODF X 1/2" ODF	YES	NO	External	NO	60	NBE 1-1/4SC-01	100227
	1-1/2	C (Medium Temp)	3/8" ODF X 1/2" ODF	YES	NO	External	NO	60	NBE 1-1/2SC-01	100235
	1-1/2	Z (Low Temp)	3/8" ODF X 1/2" ODF	YES	NO	External	NO	60	NBE 1-1/2SZ-01	100251
	2	C (Medium Temp)	3/8" ODF X 1/2" ODF	YES	NO	External	NO	30	NBE 2SC-01	100224
	2	Z (Low Temp)	3/8" ODF X 1/2" ODF	YES	NO	External	NO	60	NBE 2SZ-02	100248
	2-1/2	C (Medium Temp)	3/8" SAE X 1/2" SAE	YES	NO	External	NO	30	NBE 2-1/2SC-01	100222
	2-1/2	Z (Low Temp)	1/2" ODF X 5/8" ODF	YES	NO	External	NO	60	NBE 2-1/2SZ-01	100249
	3	C (Medium Temp)	3/8" ODF X 1/2" ODF	YES	NO	External	NO	60	NBE 3SC-01	100237
	3	Z (Low Temp)	3/8" ODF X 1/2" ODF	YES	NO	External	NO	60	NBE 3SZ-01	100250
	3-1/2	C (Medium Temp)	1/2" ODF X 5/8" ODF	YES	NO	External	NO	60	NBE 3-1/2SC-01	100225

Refrigerant	Capacity (nominal tonnage)	Charge code	Inlet x outlet connection	Adjustable superheat	Internal check	Equalizer	Bleed	Cap length (inches)	Model number	Item number
T (R-290)	1/5	A (Medium & Low Temp)	1/4" ODF X 3/8" ODF	YES	NO	Internal	NO	30	NB 1/5TA-02	100175
	1/4	A (Medium & Low Temp)	3/8" ODF X 1/2" ODF	YES	NO	Internal	NO	30	NB 1/4TA-01	100171
	1/2	A (Medium & Low Temp)	3/8" ODF X 1/2" ODF	YES	NO	Internal	NO	30	NB 1/2TA-01	100172
	1	A (Medium & Low Temp)	3/8" ODF X 1/2" ODF	YES	NO	Internal	NO	30	NB 1TA-01	100173
	1-1/2	A (Medium & Low Temp)	3/8" ODF X 1/2" ODF	YES	NO	Internal	NO	30	NB 1-1/2TA-01	100174



# TXV Connect Kits Thermostatic Expansion Valves

Copeland TXV Connect kits provide a universal retrofit and service solution. Adapters are available for Chatleff and Aeroquip connections, and an external equalizer connector makes installation easy for all residential air conditioning systems.

## Features

- ODF TXVs with internal check, Chatleff and Aeroquip adapters, external equalizer connector and bulb strap
- Fits all systems regardless of manufacturer
- R-410A and R-22 kits in multiple capacities
- R-410A valve offers stainless steel power assembly for durability
- Adapters have extended ends for ease of installation
- Easy field replacement of fixed orifice for increased efficiency

## Specifications

Maximum working pressure ..... 700 psig (48 bar)  
 UL/CUL file number (valves) ..... SA5312  
 Canadian CRN for R-22 ..... 0C21506.513467890YTN  
 Canadian CRN for R-410A ..... 0C20308.5C

### TXV Connect Kits Thermostatic Expansion Valves (body style straight thru)

System refrigerant code	Capacity (nominal tonnage)	Inlet x outlet connection	Adjustable superheat	Equalizer	Cap length	Model number	Item number
H (R-22)	1-1/2 to 3	3/8" X 1/2" ODF	Yes	External	30 In.	TXV+CONNECT 2-1/2TR-22	066657
	3-1/2 to 5	3/8" X 1/2" ODF	Yes	External	30 In.	TXV+CONNECT 5TR-22	066658
Z (R-410A)	1-1/2	3/8" X 1/2" ODF	Yes	External	5 Ft.	TXV+CONNECT 1-1/2TR-410A	066660
	2	3/8" X 1/2" ODF	Yes	External	5 Ft.	TXV+CONNECT 2TR-410A	066661
	3	3/8" X 1/2" ODF	Yes	External	5 Ft.	TXV+CONNECT 3TR-410A	066662
	4	3/8" X 1/2" ODF	Yes	External	5 Ft.	TXV+CONNECT 4TR-410A	066663
	5	3/8" X 1/2" ODF	Yes	External	5 Ft.	TXV+CONNECT 5TR-410A	066664

### TXV Connect Kits Adapters

Description	Model number	Item number
Chatleff Adapter Assembly, 1/2" ODF X Chatleff	KT-30036-1	066653
Chatleff Adapter Assembly Standard, Short, 1/2" ODF X Chatleff*	KT-30036-3	066679
Aeroquip Adapter Assembly, 1/2" ODF X Aeroquip*	KT-30037-1	066654

\* Included in kit but also available for individual purchase.



HFES 1/2FC-01

# HF Series Thermostatic Expansion Valves

The HF Series is a balanced ported valve designed for refrigeration, air conditioning and heat pump applications.

## Features

- Stainless steel replaceable power assembly eliminates corrosion and prevents valve failure
- Two body sizes provide capacities from 1/8 to 13 tons for R-404A
- Bodies, cages and power assemblies can be ordered separately or in pre-packaged service kits
- Bi-directional capability up to 3-1/2 tons for R-22 on one valve superheat control in cooling and heating
- Optional removable inlet strainer (ODF only)
- Available in straight-through or angle flow configurations
- Available with internal or external equalizer
- Available in ODF or SAE connections

## Specifications

Maximum working pressure.....450 psig (31 bar)  
 UR/CUR file number.....SA5312  
 Canadian CRN.....0C21506.513467890YTN

### Model number nomenclature - Example: HFE 1/2FC-01

Series	Superheat adjustment	Equalizer	Connection type	Removable inlet strainer	Bleed hole	Capacity	System refrigerant code	Charge code	Sequential identifier	Customer special	Pack type
HF		E				1/2	F	C	-01	G	
Balanced Port Design	N = Non-adjustable  (Omit For Adjustable)	E = External  (Omit For Internal)	S = Solder  (Omit For SAE Flare)	C = Inlet Strainer  (ODF Only)	B = Bleed Hole  (Omit For No Bleed Hole)	Nominal Rating in Tons	B = R-448A/R-449A/R-452A D = R-450A/R-513A F = R-12 H = R-22/R-407A M = R-134a N = R-407C P = R-507 R = R-502 S = R-404A/R-407H T = R-290	A = Medium & Low Temp. AA = Wide Range C = Medium Temp. CA = Heat Pump W(MOP) = Press. Limiting Z = Low Temp.	-01 Thru -999	G = Cust. Special  (Omit for Standard)	B1 = Bulk Pack  (Omit for Individual Pack)

### HF Series Thermostatic Expansion Valves (adjustable superheat models)

System refrigerant code	Capacity (nominal tonnage)	Charge code	Inlet x outlet connection	Equalizer	Bleed	Cap length	Body design	Strainer	Model number	Item number
B (R-448A, R-449A)	1/4	A (Med./Low Temp.)	1/4" X 1/2" ODF	External	No	5 Ft.	Straight Thru	No	HFES 1/4BA-01	067018
	1/4	A (Med./Low Temp.)	1/4" X 1/2" ODF	External	No	5 Ft.	Angle	Yes	HFESC 1/4BA-01	067016
	1/2	A (Med./Low Temp.)	1/4" X 1/2" ODF	External	No	5 Ft.	Straight Thru	No	HFES 1/2BA-01	067019
	1/2	A (Med./Low Temp.)	1/4" X 1/2" ODF	External	No	5 Ft.	Angle	Yes	HFESC 1/2BA-01	067017
	1/2	A (Med./Low Temp.)	3/8" X 1/2" ODF	External	No	5 Ft.	Angle	Yes	HFESC 1/2BA-02	066979
	1	A (Med./Low Temp.)	3/8" X 1/2" ODF	External	No	5 Ft.	Straight Thru	No	HFES 1BA-01	067008
	1	A (Med./Low Temp.)	3/8" X 1/2" ODF	External	No	5 Ft.	Angle	Yes	HFESC 1BA-01	066980
	1-1/2	A (Med./Low Temp.)	3/8" X 1/2" ODF	External	No	5 Ft.	Straight Thru	No	HFES 1-1/2BA-01	067009
	1-1/2	A (Med./Low Temp.)	3/8" X 1/2" ODF	External	No	5 Ft.	Angle	Yes	HFESC 1-1/2BA-01	066981
	2	A (Med./Low Temp.)	3/8" X 1/2" ODF	External	No	5 Ft.	Straight Thru	No	HFES 2BA-01	067010
	2	A (Med./Low Temp.)	3/8" X 1/2" ODF	External	No	5 Ft.	Angle	Yes	HFESC 2BA-01	066982
	2-1/2	A (Med./Low Temp.)	3/8" X 1/2" ODF	External	No	5 Ft.	Straight Thru	No	HFES 2-1/2BA-01	067011
2-1/2	A (Med./Low Temp.)	3/8" X 1/2" ODF	External	No	5 Ft.	Angle	Yes	HFESC 2-1/2BA-01	066983	
3-1/2	A (Med./Low Temp.)	3/8" X 1/2" ODF	External	No	5 Ft.	Straight Thru	No	HFES 3-1/2BA-01	067012	

All capacities shown are at 100°F condensing, 40°F evaporator temperature.

Valve capacity is for the first refrigerant listed. To determine the capacity for additional refrigerants listed, consult the nominal capacity tables for interchangeable refrigerants.

System refrigerant code	Capacity (nominal tonnage)	Charge code	Inlet x outlet connection	Equalizer	Bleed	Cap length	Body design	Strainer	Model number	Item number
B (R-448A, R-449A)	3-1/2	A (Med./Low Temp.)	3/8" X 1/2" ODF	External	No	5 Ft.	Angle	Yes	HFESC 3-1/2BA-01	066984
	6	A (Med./Low Temp.)	3/8" X 1/2" ODF	External	No	5 Ft.	Angle	Yes	HFESC 6BA-01	066985
	6	A (Med./Low Temp.)	5/8" X 7/8" ODF	External	No	5 Ft.	Straight Thru	No	HFESC 6BA-01	067013
	6	A (Med./Low Temp.)	5/8" X 7/8" ODF	External	No	5 Ft.	Angle	Yes	HFESC 6BA-02	067014
	8-1/2	A (Med./Low Temp.)	3/8" X 1/2" ODF	External	No	5 Ft.	Angle	Yes	HFESC 8-1/2BA-01	066986
	8-1/2	A (Med./Low Temp.)	5/8" X 7/8" ODF	External	No	5 Ft.	Angle	Yes	HFESC 8-1/2BA-02	067015
D (R-450A, R-513A)	1/5	A (Med./Low Temp.)	1/4" X 1/2" ODF	Internal	No	5 Ft.	Angle	No	HFS 1/5DA-01	096856
	1/5	A (Med./Low Temp.)	3/8" X 1/2" ODF	External	No	5 Ft.	Straight Thru	No	HFES 1/5DA-01	096840
	1/5	A (Med./Low Temp.)	3/8" X 1/2" ODF	External	No	5 Ft.	Angle	Yes	HFESC 1/5DA-01	096851
	1/5	A (Med./Low Temp.)	3/8" X 1/2" ODF	Internal	No	5 Ft.	Angle	Yes	HFS 1/5DA-01	096858
	1/4	A (Med./Low Temp.)	1/4" X 1/2" ODF	Internal	No	5 Ft.	Angle	No	HFS 1/4DA-01	096855
	1/4	A (Med./Low Temp.)	3/8" X 1/2" ODF	External	No	5 Ft.	Straight Thru	No	HFES 1/4DA-01	096839
	1/4	A (Med./Low Temp.)	3/8" X 1/2" ODF	External	No	5 Ft.	Angle	Yes	HFESC 1/4DA-01	096850
	1/4	A (Med./Low Temp.)	3/8" X 1/2" ODF	Internal	No	5 Ft.	Angle	Yes	HFESC 1/4DA-01	096857
	1/2	A (Med./Low Temp.)	1/4" X 1/2" ODF	Internal	No	5 Ft.	Angle	No	HFS 1/2DA-01	096854
	1/2	A (Med./Low Temp.)	3/8" X 1/2" ODF	External	No	5 Ft.	Straight Thru	No	HFES 1/2DA-01	096838
	1/2	A (Med./Low Temp.)	3/8" X 1/2" ODF	External	No	5 Ft.	Angle	Yes	HFESC 1/2DA-01	096849
	3/4	A (Med./Low Temp.)	3/8" X 1/2" ODF	External	No	5 Ft.	Straight Thru	No	HFES 3/4DA-01	096845
	3/4	A (Med./Low Temp.)	3/8" X 1/2" ODF	External	No	5 Ft.	Angle	Yes	HFESC 3/4DA-01	096853
	1	A (Med./Low Temp.)	3/8" X 1/2" ODF	External	No	5 Ft.	Straight Thru	No	HFES 1DA-01	096842
	1	A (Med./Low Temp.)	3/8" X 1/2" ODF	External	No	5 Ft.	Angle	Yes	HFESC 1DA-01	096852
	1-1/2	A (Med./Low Temp.)	3/8" X 1/2" ODF	External	No	5 Ft.	Straight Thru	No	HFES 1-1/2DA-01	096837
	2	A (Med./Low Temp.)	3/8" X 1/2" ODF	External	No	5 Ft.	Straight Thru	No	HFES 2DA-01	096843
	3-1/2	A (Med./Low Temp.)	3/8" X 1/2" ODF	External	No	5 Ft.	Straight Thru	No	HFES 3-1/2DA-01	096844
	4-1/2	A (Med./Low Temp.)	3/8" X 1/2" ODF	External	No	5 Ft.	Straight Thru	No	HFES 4-1/2DA-01	096846
	6	A (Med./Low Temp.)	5/8" X 7/8" ODF	External	No	5 Ft.	Straight Thru	No	HFES 6DA-01	096847
9	A (Med./Low Temp.)	5/8" X 7/8" ODF	External	No	5 Ft.	Straight Thru	No	HFES 9DA-01	096848	
11-1/2	A (Med./Low Temp.)	7/8" X 1-1/8" ODF	External	No	5 Ft.	Straight Thru	No	HFES 11-1/2DA-01	096841	
F (R-12) *R-134a	1/4	C (Med. Temp.)	1/4" X 1/2" SAE	Internal	No	5 Ft.	Angle	No	HF 1/4FC-01	009811
	1/4	C (Med. Temp.)	3/8" X 1/2" SAE	External	No	5 Ft.	Angle	No	HFE 1/4FC-01	054360
	1/4	C (Med. Temp.)	3/8" X 1/2" SAE	Internal	No	5 Ft.	Angle	No	HF 1/4FC-02	054134
	1/2	C (Med. Temp.)	1/4" X 1/2" SAE	External	No	5 Ft.	Angle	No	HFE 1/2FC-01	009955
	1/2	C (Med. Temp.)	1/4" X 1/2" SAE	Internal	No	5 Ft.	Angle	No	HF 1/2FC-01	009810
	1/2	C (Med. Temp.)	3/8" X 1/2" SAE	External	No	5 Ft.	Angle	No	HFE 1/2FC-02	054895
	1/2	C (Med. Temp.)	3/8" X 1/2" ODF	External	No	5 Ft.	Angle	No	HFES 1/2FC-01	056021
	1/2	C (Med. Temp.)	3/8" X 1/2" ODF	External	No	5 Ft.	Angle	Yes	HFESC 1/2FC-01	057397
	1/2	C (Med. Temp.)	3/8" X 1/2" SAE	Internal	No	5 Ft.	Angle	No	HF 1/2FC-02	054892
	1	C (Med. Temp.)	3/8" X 1/2" SAE	External	No	5 Ft.	Angle	No	HFE 1FC-01	054909
	1	C (Med. Temp.)	3/8" X 1/2" ODF	External	No	5 Ft.	Angle	No	HFES 1FC-01	055993
	1	C (Med. Temp.)	3/8" X 1/2" ODF	External	No	5 Ft.	Straight Thru	No	HFES 1FC-02	056151
	1	C (Med. Temp.)	3/8" X 1/2" ODF	External	No	5 Ft.	Angle	Yes	HFESC 1FC-01	057398
	1	C (Med. Temp.)	3/8" X 1/2" SAE	Internal	No	5 Ft.	Angle	No	HF 1FC-01	054905
	1-1/2	C (Med. Temp.)	3/8" X 1/2" SAE	External	No	5 Ft.	Angle	No	HFE 1-1/2FC-01	054917
	1-1/2	C (Med. Temp.)	3/8" X 1/2" ODF	External	No	5 Ft.	Angle	No	HFES 1-1/2FC-01	055994
	1-1/2	C (Med. Temp.)	3/8" X 1/2" ODF	External	No	5 Ft.	Angle	Yes	HFESC 1-1/2FC-01	057399
	2	C (Med. Temp.)	3/8" X 1/2" SAE	External	No	5 Ft.	Angle	No	HFE 2FC-01	053069
	2	C (Med. Temp.)	3/8" X 1/2" ODF	External	No	5 Ft.	Angle	Yes	HFESC 2FC-01	057400
	2	C (Med. Temp.)	3/8" X 1/2" SAE	Internal	No	5 Ft.	Angle	No	HF 2FC-01	053060
3-1/2	C (Med. Temp.)	3/8" X 1/2" SAE	External	No	5 Ft.	Angle	No	HFE 3-1/2FC-01	054138	
H (R-22) *R-407C	1/4	C (Med. Temp.)	1/4" X 1/2" SAE	Internal	No	5 Ft.	Angle	No	HF 1/4HC-03	058430
	1/4	C (Med. Temp.)	3/8" X 1/2" SAE	External	No	5 Ft.	Angle	No	HFE 1/4HC-01	054924
	1/4	C (Med. Temp.)	3/8" X 1/2" ODF	External	No	5 Ft.	Straight Thru	No	HFES 1/4HC-01	055927
	1/4	C (Med. Temp.)	3/8" X 1/2" ODF	External	No	5 Ft.	Angle	Yes	HFESC 1/4HC-01	057409
	1/4	C (Med. Temp.)	3/8" X 1/2" SAE	Internal	No	5 Ft.	Angle	No	HF 1/4HC-01	054921
	1/4	C (Med. Temp.)	3/8" X 1/2" ODF	Internal	No	5 Ft.	Straight Thru	No	HFS 1/4HC-02	055633
	1/4	C (Med. Temp.)	3/8" X 1/2" ODF	Internal	No	5 Ft.	Angle	Yes	HFSC 1/4HC-01	057467

System refrigerant code	Capacity (nominal tonnage)	Charge code	Inlet x outlet connection	Equalizer	Bleed	Cap length	Body design	Strainer	Model number	Item number
H (R-22) R-407C	1/4	Z (Low Temp.)	1/4" X 1/2" SAE	Internal	No	5 Ft.	Angle	No	HF 1/4HZ-01	059653
	1/4	Z (Low Temp.)	3/8" X 1/2" SAE	External	No	5 Ft.	Angle	No	HFE 1/4HZ-01	054925
	1/4	Z (Low Temp.)	3/8" X 1/2" ODF	External	No	5 Ft.	Angle	Yes	HFESC 1/4HZ-01	057428
	1/2	C (Med. Temp.)	1/4" X 1/2" SAE	External	No	5 Ft.	Angle	No	HFE 1/2HC-02	059079
	1/2	C (Med. Temp.)	1/4" X 1/2" SAE	Internal	No	5 Ft.	Angle	No	HF 1/2HC-01	009812
	1/2	C (Med. Temp.)	3/8" X 1/2" SAE	External	No	5 Ft.	Angle	No	HFE 1/2HC-01	054361
	1/2	C (Med. Temp.)	3/8" X 1/2" ODF	External	No	5 Ft.	Angle	No	HFES 1/2HC-01	054838
	1/2	C (Med. Temp.)	3/8" X 1/2" ODF	External	No	5 Ft.	Straight Thru	No	HFES 1/2HC-02	055827
	1/2	C (Med. Temp.)	3/8" X 1/2" ODF	External	No	5 Ft.	Angle	Yes	HFESC 1/2HC-01	057291
	1/2	C (Med. Temp.)	3/8" X 1/2" SAE	Internal	No	5 Ft.	Angle	No	HF 1/2HC-02	054135
	1/2	C (Med. Temp.)	3/8" X 1/2" ODF	Internal	No	5 Ft.	Straight Thru	No	HFS 1/2HC-02	054136
	1/2	C (Med. Temp.)	3/8" X 1/2" ODF	Internal	No	5 Ft.	Angle	Yes	HFSC 1/2HC-01	057293
	1/2	Z (Low Temp.)	3/8" X 1/2" SAE	External	No	5 Ft.	Angle	No	HFE 1/2HZ-01	054365
	1/2	Z (Low Temp.)	3/8" X 1/2" ODF	External	No	5 Ft.	Straight Thru	No	HFES 1/2HZ-01	055889
	1/2	Z (Low Temp.)	3/8" X 1/2" SAE	Internal	No	5 Ft.	Angle	No	HF 1/2HZ-01	054364
	1	C (Med. Temp.)	3/8" X 1/2" SAE	External	No	5 Ft.	Angle	No	HFE 1HC-01	054930
	1	C (Med. Temp.)	3/8" X 1/2" ODF	External	No	5 Ft.	Angle	No	HFES 1HC-01	055494
	1	C (Med. Temp.)	3/8" X 1/2" ODF	External	No	5 Ft.	Straight Thru	No	HFES 1HC-02	055708
	1	C (Med. Temp.)	3/8" X 1/2" ODF	External	No	5 Ft.	Angle	Yes	HFESC 1HC-01	057410
	1	C (Med. Temp.)	3/8" X 1/2" SAE	Internal	No	5 Ft.	Angle	No	HF 1HC-01	054927
	1	C (Med. Temp.)	3/8" X 1/2" ODF	Internal	No	5 Ft.	Angle	No	HFS 1HC-01	055702
	1	C (Med. Temp.)	3/8" X 1/2" ODF	Internal	No	5 Ft.	Angle	Yes	HFSC 1HC-01	057468
	1	Z (Low Temp.)	3/8" X 1/2" SAE	External	No	5 Ft.	Angle	No	HFE 1HZ-01	054931
	1	Z (Low Temp.)	3/8" X 1/2" ODF	External	No	5 Ft.	Angle	Yes	HFESC 1HZ-01	057430
	1	Z (Low Temp.)	3/8" X 1/2" SAE	Internal	No	5 Ft.	Angle	No	HF 1HZ-01	054928
	1-1/2	C (Med. Temp.)	3/8" X 1/2" SAE	External	No	5 Ft.	Angle	No	HFE 1-1/2HC-01	054936
	1-1/2	C (Med. Temp.)	3/8" X 1/2" ODF	External	No	5 Ft.	Angle	No	HFES 1-1/2HC-01	055495
	1-1/2	C (Med. Temp.)	3/8" X 1/2" ODF	External	No	5 Ft.	Straight Thru	No	HFES 1-1/2HC-02	055863
	1-1/2	C (Med. Temp.)	3/8" X 1/2" ODF	External	No	5 Ft.	Angle	Yes	HFESC 1-1/2HC-01	057292
	1-1/2	C (Med. Temp.)	3/8" X 1/2" SAE	Internal	No	5 Ft.	Angle	No	HF 1-1/2HC-01	054933
	1-1/2	C (Med. Temp.)	3/8" X 1/2" ODF	Internal	No	5 Ft.	Straight Thru	No	HFS 1-1/2HC-02	056018
	1-1/2	Z (Low Temp.)	3/8" X 1/2" SAE	External	No	5 Ft.	Angle	No	HFE 1-1/2HZ-01	054937
	1-1/2	Z (Low Temp.)	3/8" X 1/2" ODF	External	No	5 Ft.	Straight Thru	No	HFES 1-1/2HZ-01	055870
	2	C (Med. Temp.)	3/8" X 1/2" SAE	External	No	5 Ft.	Angle	No	HFE 2HC-01	054942
	2	C (Med. Temp.)	3/8" X 1/2" ODF	External	No	5 Ft.	Angle	No	HFES 2HC-01	054946
	2	C (Med. Temp.)	3/8" X 1/2" ODF	External	No	5 Ft.	Straight Thru	No	HFES 2HC-02	055706
	2	C (Med. Temp.)	3/8" X 1/2" ODF	External	No	5 Ft.	Angle	Yes	HFESC 2HC-01	057294
	2	C (Med. Temp.)	3/8" X 1/2" SAE	Internal	No	5 Ft.	Angle	No	HF 2HC-01	054939
	2	CA (Heat Pump)	3/8" X 1/2" ODF	External	No	5 Ft.	Straight Thru	No	HFES 2HCA-01	059670
	2	Z (Low Temp.)	3/8" X 1/2" SAE	External	No	5 Ft.	Angle	No	HFE 2HZ-01	054943
	2	Z (Low Temp.)	3/8" X 1/2" ODF	External	No	5 Ft.	Angle	Yes	HFESC 2HZ-01	057433
	2	Z (Low Temp.)	3/8" X 1/2" SAE	Internal	No	5 Ft.	Angle	No	HF 2HZ-01	054940
	2-1/2	C (Med. Temp.)	3/8" X 1/2" SAE	External	No	5 Ft.	Angle	No	HFE 2-1/2HC-01	054950
	2-1/2	C (Med. Temp.)	3/8" X 1/2" ODF	External	No	5 Ft.	Straight Thru	No	HFES 2-1/2HC-01	055931
	2-1/2	C (Med. Temp.)	3/8" X 1/2" ODF	External	No	5 Ft.	Angle	No	HFES 2-1/2HC-02	056042
	2-1/2	C (Med. Temp.)	3/8" X 1/2" ODF	External	No	5 Ft.	Angle	Yes	HFESC 2-1/2HC-01	057411
	3	C (Med. Temp.)	3/8" X 1/2" SAE	External	No	5 Ft.	Angle	No	HFE 3HC-01	053317
	3	C (Med. Temp.)	3/8" X 1/2" ODF	External	No	5 Ft.	Straight Thru	No	HFES 3HC-01	053916
	3	C (Med. Temp.)	3/8" X 1/2" ODF	External	No	5 Ft.	Angle	No	HFES 3HC-02	054756
	3	C (Med. Temp.)	3/8" X 1/2" ODF	External	No	5 Ft.	Angle	Yes	HFESC 3HC-01	057412
3	C (Med. Temp.)	3/8" X 1/2" SAE	Internal	No	5 Ft.	Angle	No	HF 3HC-01	053316	
3	CA (Heat Pump)	1/2" X 5/8" ODF	External	No	5 Ft.	Straight Thru	No	HFES 3HCA-01	061730	
3	Z (Low Temp.)	3/8" X 1/2" SAE	External	No	5 Ft.	Angle	No	HFE 3HZ-01	053191	
3	Z (Low Temp.)	1/2" X 5/8" ODF	External	No	5 Ft.	Angle	No	HFES 3HZ-02	064761	
5-1/2	C (Med. Temp.)	3/8" X 1/2" SAE	External	No	5 Ft.	Angle	No	HFE 5-1/2HC-01	054140	
5-1/2	C (Med. Temp.)	3/8" X 1/2" ODF	External	No	5 Ft.	Straight Thru	No	HFES 5-1/2HC-01	054141	

System refrigerant code	Capacity (nominal tonnage)	Charge code	Inlet x outlet connection	Equalizer	Bleed	Cap length	Body design	Strainer	Model number	Item number
H (R-22) *R-407C	5-1/2	C (Med. Temp.)	3/8" X 1/2" ODF	External	No	5 Ft.	Angle	Yes	HFESC 5-1/2HC-01	057781
	5-1/2	C (Med. Temp.)	1/2" X 5/8" ODF	External	No	5 Ft.	Straight Thru	No	HFES 5-1/2HC-02	054778
	5-1/2	C (Med. Temp.)	1/2" X 7/8" ODF	External	No	5 Ft.	Straight Thru	No	HFES 5-1/2HC-04	055187
	5-1/2	C (Med. Temp.)	5/8" X 7/8" ODF	External	No	5 Ft.	Straight Thru	No	HFES 5-1/2HC-03	054779
	5-1/2	CA (Heat Pump)	1/2" X 5/8" ODF	External	No	5 Ft.	Straight Thru	No	HFES 5-1/2HCA-02	057378
	5-1/2	Z (Low Temp.)	3/8" X 1/2" SAE	External	No	5 Ft.	Angle	No	HFE 5-1/2HZ-01	054777
	8	C (Med. Temp.)	1/2" X 5/8" ODF	External	No	5 Ft.	Straight Thru	No	HFES 8HC-01	057312
	8	C (Med. Temp.)	5/8" X 7/8" ODF	External	No	5 Ft.	Straight Thru	No	HFES 8HC-02	057313
	8	CA (Heat Pump)	1/2" X 7/8" ODF	External	No	5 Ft.	Straight Thru	No	HFES 8HCA-04	056818
	8	CA (Heat Pump)	5/8" X 7/8" ODF	External	No	5 Ft.	Straight Thru	No	HFES 8HCA-05	056819
	8	W100 (MOP)	5/8" X 7/8" ODF	External	No	5 Ft.	Straight Thru	No	HFES 8HW100-01	057354
	10	C (Med. Temp.)	1/2" X 5/8" ODF	External	No	5 Ft.	Straight Thru	No	HFES 10HC-02	057315
	10	C (Med. Temp.)	5/8" X 7/8" ODF	External	No	5 Ft.	Straight Thru	No	HFES 10HC-01	057256
	10	C (Med. Temp.)	7/8" X 1-1/8" ODF	External	No	5 Ft.	Straight Thru	No	HFES 10HC-03	057316
	10	CA (Heat Pump)	5/8" X 7/8" ODF	External	No	5 Ft.	Straight Thru	No	HFES 10HCA-05	056820
	10	CA (Heat Pump)	5/8" X 1-1/8" ODF	External	No	5 Ft.	Straight Thru	No	HFES 10HCA-06	056821
	10	W100 (MOP)	5/8" X 7/8" ODF	External	No	5 Ft.	Straight Thru	No	HFES 10HW100-01	058159
	12	C (Med. Temp.)	5/8" X 7/8" ODF	External	No	5 Ft.	Straight Thru	No	HFES 12HC-01	062737
	15	C (Med. Temp.)	5/8" X 7/8" ODF	External	No	5 Ft.	Straight Thru	No	HFES 15HC-01	057317
	15	C (Med. Temp.)	7/8" X 1-1/8" ODF	External	No	5 Ft.	Straight Thru	No	HFES 15HC-02	057318
15	CA (Heat Pump)	5/8" X 7/8" ODF	External	No	5 Ft.	Straight Thru	No	HFES 15HCA-07	056823	
15	CA (Heat Pump)	5/8" X 1-1/8" ODF	External	No	5 Ft.	Straight Thru	No	HFES 15HCA-08	056824	
15	CA (Heat Pump)	7/8" X 1-1/8" ODF	External	No	5 Ft.	Straight Thru	No	HFES 15HCA-09	056825	
20	C (Med. Temp.)	7/8" X 1-1/8" ODF	External	No	5 Ft.	Straight Thru	No	HFES 20HC-01	062055	
20	CA (Heat Pump)	7/8" X 1-1/8" ODF	External	No	5 Ft.	Straight Thru	No	HFES 20HCA-04	058490	
M (R-134a) *R-12	1/4	C (Med. Temp.)	3/8" X 1/2" SAE	External	No	30 In.	Angle	No	HFE 1/4MC-01	057860
	1/4	C (Med. Temp.)	3/8" X 1/2" ODF	External	No	5 Ft.	Angle	Yes	HFESC 1/4MC-01	057572
	1/4	C (Med. Temp.)	3/8" X 1/2" ODF	Internal	No	5 Ft.	Angle	Yes	HFSC 1/4MC-01	057573
	1/2	C (Med. Temp.)	3/8" X 1/2" SAE	External	No	5 Ft.	Angle	No	HFE 1/2MC-01	057616
	1/2	C (Med. Temp.)	3/8" X 1/2" ODF	External	No	5 Ft.	Straight Thru	No	HFES 1/2MC-01	065645
	1/2	C (Med. Temp.)	3/8" X 1/2" ODF	External	No	5 Ft.	Angle	Yes	HFESC 1/2MC-01	058069
	1/2	C (Med. Temp.)	3/8" X 1/2" SAE	Internal	No	5 Ft.	Angle	No	HF 1/2MC-01	057620
	1/2	C (Med. Temp.)	3/8" X 1/2" ODF	Internal	No	5 Ft.	Straight Thru	No	HFS 1/2MC-01	058100
	1/2	C (Med. Temp.)	3/8" X 1/2" ODF	Internal	No	5 Ft.	Angle	Yes	HFESC 1/2MC-01	058067
	3/4	C (Med. Temp.)	3/8" X 1/2" SAE	External	No	30 In.	Angle	No	HFE 3/4MC-01	057861
	3/4	C (Med. Temp.)	3/8" X 1/2" ODF	External	No	5 Ft.	Straight Thru	No	HFES 3/4MC-02	059422
	1	C (Med. Temp.)	3/8" X 1/2" SAE	External	No	5 Ft.	Angle	No	HFE 1MC-01	057617
	1	C (Med. Temp.)	3/8" X 1/2" ODF	External	No	5 Ft.	Angle	No	HFES 1MC-01	058546
	1	C (Med. Temp.)	3/8" X 1/2" ODF	External	No	5 Ft.	Straight Thru	No	HFES 1MC-02	065646
	1	C (Med. Temp.)	3/8" X 1/2" ODF	External	No	5 Ft.	Angle	Yes	HFESC 1MC-01	057570
	1-1/2	C (Med. Temp.)	3/8" X 1/2" SAE	External	No	5 Ft.	Angle	No	HFE 1-1/2MC-01	057895
	1-1/2	C (Med. Temp.)	3/8" X 1/2" ODF	External	No	5 Ft.	Angle	Yes	HFESC 1-1/2MC-01	057568
	1-3/4	C (Med. Temp.)	3/8" X 1/2" ODF	External	No	5 Ft.	Straight Thru	No	HFES 1-3/4MC-02	065647
	2-1/2	C (Med. Temp.)	3/8" X 1/2" ODF	External	No	5 Ft.	Angle	Yes	HFESC 2-1/2MC-01	058421
	4	C (Med. Temp.)	3/8" X 1/2" SAE	External	No	5 Ft.	Angle	No	HFE 4MC-01	057897
4	C (Med. Temp.)	1/2" X 5/8" ODF	External	No	5 Ft.	Straight Thru	No	HFES 4MC-01	058680	
6	C (Med. Temp.)	5/8" X 7/8" ODF	External	No	5 Ft.	Straight Thru	No	HFES 6MC-01	057903	
7-1/2	C (Med. Temp.)	5/8" X 7/8" ODF	External	No	5 Ft.	Straight Thru	No	HFES 7-1/2MC-01	057904	
11	C (Med. Temp.)	5/8" X 7/8" ODF	External	No	5 Ft.	Straight Thru	No	HFES 11MC-02	057906	
11	C (Med. Temp.)	7/8" X 1-1/8" ODF	External	No	5 Ft.	Straight Thru	No	HFES 11MC-03	058681	
14	C (Med. Temp.)	7/8" X 1-3/8" ODF	External	No	5 Ft.	Straight Thru	No	HFES 14MC-02	064000	
R (R-502) *R-404A *R-507	1/4	C (Med. Temp.)	1/4" X 1/2" SAE	Internal	No	5 Ft.	Angle	No	HF 1/4RC-02	059304
	1/4	C (Med. Temp.)	3/8" X 1/2" SAE	External	No	5 Ft.	Angle	No	HFE 1/4RC-01	054366
	1/4	C (Med. Temp.)	3/8" X 1/2" ODF	External	No	5 Ft.	Angle	No	HFES 1/4RC-01	055092
	1/4	C (Med. Temp.)	3/8" X 1/2" ODF	External	No	5 Ft.	Angle	Yes	HFESC 1/4RC-01	057436

System refrigerant code	Capacity (nominal tonnage)	Charge code	Inlet x outlet connection	Equalizer	Bleed	Cap length	Body design	Strainer	Model number	Item number
R (R-502) *R-404A *R-507	1/4	C (Med. Temp.)	3/8" X 1/2" SAE	Internal	No	5 Ft.	Angle	No	HF 1/4RC-01	054137
	1/4	C (Med. Temp.)	3/8" X 1/2" ODF	Internal	No	5 Ft.	Angle	No	HFS 1/4RC-01	055490
	1/4	W45 (MOP)	3/8" X 1/2" SAE	External	No	5 Ft.	Angle	No	HFE 1/4RW45-01	054963
	1/4	Z (Low Temp.)	1/4" X 3/8" ODF	Internal	No	5 Ft.	Straight Thru	No	HFS 1/4RZ-01	055792
	1/4	Z (Low Temp.)	3/8" X 1/2" ODF	External	No	5 Ft.	Angle	Yes	HFESC 1/4RZ-01	057454
	1/4	Z (Low Temp.)	3/8" X 1/2" SAE	Internal	No	5 Ft.	Angle	No	HF 1/4RZ-01	054369
	1/2	C (Med. Temp.)	3/8" X 1/2" SAE	External	No	5 Ft.	Angle	No	HFE 1/2RC-01	054967
	1/2	C (Med. Temp.)	3/8" X 1/2" ODF	External	No	5 Ft.	Angle	No	HFES 1/2RC-01	055992
	1/2	C (Med. Temp.)	3/8" X 1/2" ODF	External	No	5 Ft.	Straight Thru	No	HFES 1/2RC-02	056022
	1/2	C (Med. Temp.)	3/8" X 1/2" ODF	External	No	5 Ft.	Angle	Yes	HFESC 1/2RC-01	057437
	1/2	C (Med. Temp.)	3/8" X 1/2" SAE	Internal	No	5 Ft.	Angle	No	HF 1/2RC-01	054964
	1/2	W45 (MOP)	3/8" X 1/2" SAE	External	No	5 Ft.	Angle	No	HFE 1/2RW45-01	054969
	1/2	W45 (MOP)	3/8" X 1/2" ODF	External	No	5 Ft.	Angle	No	HFES 1/2RW45-01	055996
	1/2	W45 (MOP)	3/8" X 1/2" ODF	External	No	5 Ft.	Angle	Yes	HFESC 1/2RW45-01	057443
	1/2	Z (Low Temp.)	3/8" X 1/2" SAE	External	No	5 Ft.	Angle	No	HFE 1/2RZ-01	054968
	1/2	Z (Low Temp.)	3/8" X 1/2" ODF	External	No	5 Ft.	Angle	No	HFES 1/2RZ-01	055497
	1/2	Z (Low Temp.)	3/8" X 1/2" ODF	External	No	5 Ft.	Straight Thru	No	HFES 1/2RZ-02	056024
	1/2	Z (Low Temp.)	3/8" X 1/2" ODF	External	No	5 Ft.	Angle	Yes	HFESC 1/2RZ-01	057455
	1/2	Z (Low Temp.)	3/8" X 1/2" SAE	Internal	No	5 Ft.	Angle	No	HF 1/2RZ-01	054965
	1/2	Z (Low Temp.)	3/8" X 1/2" ODF	Internal	No	5 Ft.	Angle	Yes	HFSC 1/2RZ-01	057485
	1	C (Med. Temp.)	3/8" X 1/2" SAE	External	No	5 Ft.	Angle	No	HFE 1RC-01	054979
	1	C (Med. Temp.)	3/8" X 1/2" ODF	External	No	5 Ft.	Angle	No	HFES 1RC-01	054983
	1	C (Med. Temp.)	3/8" X 1/2" ODF	External	No	5 Ft.	Straight Thru	No	HFES 1RC-02	056029
	1	C (Med. Temp.)	3/8" X 1/2" ODF	External	No	5 Ft.	Angle	Yes	HFESC 1RC-01	057438
	1	C (Med. Temp.)	3/8" X 1/2" SAE	Internal	No	5 Ft.	Angle	No	HF 1RC-01	054976
	1	C (Med. Temp.)	3/8" X 1/2" ODF	Internal	No	5 Ft.	Angle	Yes	HFSC 1RC-01	057489
	1	W45 (MOP)	3/8" X 1/2" SAE	External	No	5 Ft.	Angle	No	HFE 1RW45-01	054981
	1	W45 (MOP)	3/8" X 1/2" ODF	External	No	5 Ft.	Straight Thru	No	HFES 1RW45-01	055948
	1	W45 (MOP)	3/8" X 1/2" ODF	External	No	5 Ft.	Angle	Yes	HFESC 1RW45-01	057446
	1	Z (Low Temp.)	3/8" X 1/2" SAE	External	No	5 Ft.	Angle	No	HFE 1RZ-01	054980
	1	Z (Low Temp.)	3/8" X 1/2" ODF	External	No	5 Ft.	Angle	No	HFES 1RZ-01	055496
	1	Z (Low Temp.)	3/8" X 1/2" ODF	External	No	5 Ft.	Straight Thru	No	HFES 1RZ-02	056225
	1	Z (Low Temp.)	3/8" X 1/2" ODF	External	No	5 Ft.	Angle	Yes	HFESC 1RZ-01	057456
	1	Z (Low Temp.)	3/8" X 1/2" SAE	Internal	No	5 Ft.	Angle	No	HF 1RZ-01	054977
	1-1/2	C (Med. Temp.)	3/8" X 1/2" SAE	External	No	5 Ft.	Angle	No	HFE 1-1/2RC-01	054988
	1-1/2	C (Med. Temp.)	3/8" X 1/2" ODF	External	No	5 Ft.	Angle	No	HFES 1-1/2RC-01	055657
	1-1/2	C (Med. Temp.)	3/8" X 1/2" ODF	External	No	5 Ft.	Straight Thru	No	HFES 1-1/2RC-02	056031
	1-1/2	C (Med. Temp.)	3/8" X 1/2" ODF	External	No	5 Ft.	Angle	Yes	HFESC 1-1/2RC-01	057439
	1-1/2	W45 (MOP)	3/8" X 1/2" SAE	External	No	5 Ft.	Angle	No	HFE 1-1/2RW45-01	054990
	1-1/2	Z (Low Temp.)	3/8" X 1/2" SAE	External	No	5 Ft.	Angle	No	HFE 1-1/2RZ-01	054989
	1-1/2	Z (Low Temp.)	3/8" X 1/2" ODF	External	No	5 Ft.	Straight Thru	No	HFES 1-1/2RZ-02	055878
	1-1/2	Z (Low Temp.)	3/8" X 1/2" ODF	External	No	5 Ft.	Angle	Yes	HFESC 1-1/2RZ-01	057322
	1-1/2	Z (Low Temp.)	3/8" X 1/2" SAE	Internal	No	5 Ft.	Angle	No	HF 1-1/2RZ-01	054986
	2	C (Med. Temp.)	3/8" X 1/2" SAE	External	No	5 Ft.	Angle	No	HFE 2RC-01	053070
	2	C (Med. Temp.)	3/8" X 1/2" ODF	External	No	5 Ft.	Straight Thru	No	HFES 2RC-02	053270
	2	C (Med. Temp.)	3/8" X 1/2" ODF	External	No	5 Ft.	Angle	No	HFES 2RC-03	054768
	2	C (Med. Temp.)	3/8" X 1/2" ODF	External	No	5 Ft.	Angle	Yes	HFESC 2RC-01	057440
	2	C (Med. Temp.)	3/8" X 1/2" SAE	Internal	No	5 Ft.	Angle	No	HF 2RC-01	053061
	2	Z (Low Temp.)	3/8" X 1/2" SAE	External	No	5 Ft.	Angle	No	HFE 2RZ-01	053071
	2	Z (Low Temp.)	3/8" X 1/2" ODF	External	No	5 Ft.	Straight Thru	No	HFES 2RZ-01	053271
2	Z (Low Temp.)	3/8" X 1/2" ODF	External	No	5 Ft.	Angle	No	HFES 2RZ-02	054844	
2	Z (Low Temp.)	3/8" X 1/2" ODF	External	No	5 Ft.	Angle	Yes	HFESC 2RZ-01	057457	
3-1/2	C (Med. Temp.)	3/8" X 1/2" SAE	External	No	5 Ft.	Angle	No	HFE 3-1/2RC-01	054142	
3-1/2	C (Med. Temp.)	3/8" X 1/2" ODF	External	No	5 Ft.	Straight Thru	No	HFES 3-1/2RC-01	054143	
3-1/2	C (Med. Temp.)	3/8" X 1/2" ODF	External	No	5 Ft.	Angle	Yes	HFESC 3-1/2RC-01	057441	
3-1/2	C (Med. Temp.)	3/8" X 1/2" SAE	Internal	No	5 Ft.	Angle	No	HF 3-1/2RC-01	055936	

System refrigerant code	Capacity (nominal tonnage)	Charge code	Inlet x outlet connection	Equalizer	Bleed	Cap length	Body design	Strainer	Model number	Item number
R (R-502) *R-404A *R-507	3-1/2	C (Med. Temp.)	1/2" X 5/8" ODF	External	No	5 Ft.	Straight Thru	No	HFES 3-1/2RC-02	054783
	3-1/2	W 45 (MOP)	1/2" X 5/8" ODF	External	No	5 Ft.	Straight Thru	No	HFES 3-1/2RW45-01	058907
	3-1/2	Z (Low Temp.)	3/8" X 1/2" ODF	External	No	5 Ft.	Angle	Yes	HFESC 3-1/2RZ-01	057458
	3-1/2	Z (Low Temp.)	1/2" X 5/8" ODF	External	No	5 Ft.	Straight Thru	No	HFES 3-1/2RZ-02	054785
	5	C (Med. Temp.)	3/8" X 1/2" ODF	External	No	5 Ft.	Straight Thru	No	HFES 5RC-02	058875
	5	C (Med. Temp.)	3/8" X 1/2" ODF	External	No	5 Ft.	Angle	Yes	HFESC 5RC-01	058595
	5	C (Med. Temp.)	5/8" X 7/8" ODF	External	No	5 Ft.	Straight Thru	No	HFES 5RC-01	058608
	5	W45 (MOP)	5/8" X 7/8" ODF	External	No	5 Ft.	Straight Thru	No	HFES 5RW45-01	058305
	5	Z (Low Temp.)	1/2" X 5/8" ODF	External	No	5 Ft.	Straight Thru	No	HFES 5RZ-02	061196
	5	Z (Low Temp.)	1/2" X 7/8" ODF	External	No	5 Ft.	Straight Thru	No	HFES 5RZ-01	059624
S (R-404A) *R-502 *R-507	7	C (Med. Temp.)	5/8" X 7/8" ODF	External	No	5 Ft.	Straight Thru	No	HFES 7RC-01	058607
	10	C (Med. Temp.)	5/8" X 7/8" ODF	External	No	5 Ft.	Straight Thru	No	HFES 10RC-01	058808
	1/8	C (Med. Temp.)	3/8" X 1/2" ODF	Internal	No	5 Ft.	Angle	Yes	HFSC 1/8SC-01	058248
	1/8	Z (Low Temp.)	1/4" X 1/2" ODF	Internal	No	30 In.	Angle	Yes	HFSC 1/8SZ-01	066553
	1/4	C (Med. Temp.)	1/4" X 1/2" ODF	Internal	No	30 In.	Straight Thru	No	HFS 1/4SC-01	066516
	1/4	C (Med. Temp.)	1/4" X 1/2" SAE	Internal	No	5 Ft.	Angle	No	HF 1/4SC-01	066039
	1/4	C (Med. Temp.)	3/8" X 1/2" ODF	External	No	30 In.	Straight Thru	No	HFES 1/4SC-01	066533
	1/4	C (Med. Temp.)	3/8" X 1/2" ODF	External	No	30 In.	Angle	Yes	HFESC 1/4SC-02	066539
	1/4	C (Med. Temp.)	3/8" X 1/2" ODF	Internal	No	5 Ft.	Angle	Yes	HFSC 1/4SC-01	058249
	1/4	W45 (MOP)	1/4" X 1/2" ODF	External	No	30 In.	Angle	Yes	HFESC 1/4SW45-01	066540
	1/4	W45 (MOP)	1/4" X 1/2" ODF	Internal	No	30 In.	Straight Thru	No	HFS 1/4SW45-01	066517
	1/4	Z (Low Temp.)	1/4" X 1/2" ODF	External	No	30 In.	Angle	Yes	HFESC 1/4SZ-02	066542
	1/4	Z (Low Temp.)	1/4" X 1/2" ODF	Internal	No	30 In.	Straight Thru	No	HFS 1/4SZ-01	066518
	1/4	Z (Low Temp.)	1/4" X 1/2" ODF	Internal	No	30 In.	Angle	Yes	HFSC 1/4SZ-01	066555
	1/4	Z (Low Temp.)	3/8" X 1/2" ODF	External	No	5 Ft.	Straight Thru	No	HFES 1/4SZ-01	065733
	1/2	C (Med. Temp.)	1/4" X 1/2" ODF	External	No	30 In.	Angle	Yes	HFESC 1/2SC-03	066543
	1/2	C (Med. Temp.)	1/4" X 1/2" ODF	Internal	No	30 In.	Straight Thru	No	HFS 1/2SC-01	066519
	1/2	C (Med. Temp.)	3/8" X 1/2" SAE	External	No	5 Ft.	Angle	No	HFE 1/2SC-01	062147
	1/2	C (Med. Temp.)	3/8" X 1/2" ODF	External	No	5 Ft.	Angle	No	HFES 1/2SC-01	058975
	1/2	C (Med. Temp.)	3/8" X 1/2" ODF	External	No	5 Ft.	Angle	Yes	HFESC 1/2SC-02	058141
	1/2	W45 (MOP)	1/4" X 1/2" ODF	External	No	30 In.	Angle	Yes	HFESC 1/2SW45-02	066544
	1/2	W45 (MOP)	1/4" X 1/2" ODF	Internal	No	30 In.	Angle	Yes	HFSC 1/2SW45-01	066556
	1/2	W45 (MOP)	3/8" X 1/2" SAE	External	No	5 Ft.	Angle	No	HFE 1/2SW45-01	066040
	1/2	W45 (MOP)	3/8" X 1/2" ODF	External	No	5 Ft.	Straight Thru	No	HFES 1/2SW45-01	065736
	1/2	Z (Low Temp.)	1/4" X 1/2" ODF	Internal	No	30 In.	Straight Thru	No	HFS 1/2SZ-01	066521
	1/2	Z (Low Temp.)	3/8" X 1/2" ODF	External	No	5 Ft.	Angle	No	HFES 1/2SZ-01	058995
	1/2	Z (Low Temp.)	3/8" X 1/2" ODF	External	No	5 Ft.	Angle	Yes	HFESC 1/2SZ-01	058147
	1/2	Z (Low Temp.)	3/8" X 1/2" SAE	Internal	No	5 Ft.	Angle	No	HF 1/2SZ-01	066037
	1/2	C (Med. Temp.)	3/8" X 1/2" ODF	Internal	No	5 Ft.	Angle	Yes	HFSC 1/2SC-01	058250
	1	C (Med. Temp.)	3/8" X 1/2" SAE	External	No	5 Ft.	Angle	No	HFE 1SC-01	062148
	1	C (Med. Temp.)	3/8" X 1/2" ODF	External	No	5 Ft.	Angle	No	HFES 1SC-01	058976
	1	C (Med. Temp.)	3/8" X 1/2" ODF	External	No	5 Ft.	Straight Thru	No	HFES 1SC-02	065650
1	C (Med. Temp.)	3/8" X 1/2" ODF	External	No	5 Ft.	Angle	Yes	HFESC 1SC-01	058135	
1	C (Med. Temp.)	3/8" X 1/2" ODF	Internal	No	5 Ft.	Straight Thru	No	HFS 1SC-01	065643	
1	W45 (MOP)	3/8" X 1/2" SAE	External	No	5 Ft.	Angle	No	HFE 1SW45-01	066624	
1	W45 (MOP)	3/8" X 1/2" ODF	External	No	5 Ft.	Straight Thru	No	HFES 1SW45-02	065651	
1	W45 (MOP)	3/8" X 1/2" ODF	External	No	5 Ft.	Angle	Yes	HFESC 1SW45-01	058157	
1	Z (Low Temp.)	3/8" X 1/2" SAE	External	No	5 Ft.	Angle	No	HFE 1SZ-01	058363	
1	Z (Low Temp.)	3/8" X 1/2" ODF	External	No	5 Ft.	Straight Thru	No	HFES 1SZ-01	064289	
1	Z (Low Temp.)	3/8" X 1/2" ODF	External	No	5 Ft.	Angle	Yes	HFESC 1SZ-01	058118	
1-1/4	C (Med. Temp.)	3/8" X 1/2" SAE	External	No	5 Ft.	Angle	No	HFE 1-1/4SC-01	062149	
1-1/4	C (Med. Temp.)	3/8" X 1/2" ODF	External	No	5 Ft.	Angle	No	HFES 1-1/4SC-01	058977	
1-1/4	C (Med. Temp.)	3/8" X 1/2" ODF	External	No	5 Ft.	Angle	Yes	HFESC 1-1/4SC-01	058206	
1-1/4	W45 (MOP)	3/8" X 1/2" ODF	External	No	5 Ft.	Straight Thru	No	HFES 1-1/4SW45-01	057976	
1-1/4	W45 (MOP)	3/8" X 1/2" ODF	Internal	No	5 Ft.	Angle	Yes	HFSC 1-1/4SW45-01	066560	
1-1/4	Z (Low Temp.)	3/8" X 1/2" ODF	External	No	5 Ft.	Straight Thru	No	HFES 1-1/4SZ-01	065737	

System refrigerant code	Capacity (nominal tonnage)	Charge code	Inlet x outlet connection	Equalizer	Bleed	Cap length	Body design	Strainer	Model number	Item number
S (R-404A) *R-502 *R-507	1-1/4	Z (Low Temp.)	3/8" X 1/2" ODF	Internal	No	5 Ft.	Angle	Yes	HFSC 1-1/4SZ-01	066561
	1-1/2	C (Med. Temp.)	3/8" X 1/2" SAE	External	No	5 Ft.	Angle	No	HFE 1-1/2SC-01	058309
	1-1/2	C (Med. Temp.)	3/8" X 1/2" ODF	External	No	5 Ft.	Straight Thru	No	HFES 1-1/2SC-01	057974
	1-1/2	C (Med. Temp.)	3/8" X 1/2" ODF	External	No	5 Ft.	Angle	Yes	HFESC 1-1/2SC-01	058119
	1-1/2	W45 (MOP)	3/8" X 1/2" ODF	External	No	5 Ft.	Straight Thru	No	HFES 1-1/2SW45-01	065738
	1-1/2	W45 (MOP)	3/8" X 1/2" ODF	External	No	5 Ft.	Angle	Yes	HFESC 1-1/2SW45-01	058136
	1-1/2	Z (Low Temp.)	3/8" X 1/2" ODF	External	No	5 Ft.	Straight Thru	No	HFES 1-1/2SZ-01	064290
	1-1/2	Z (Low Temp.)	3/8" X 1/2" ODF	External	No	5 Ft.	Angle	Yes	HFESC 1-1/2SZ-01	058121
	1-1/2	Z (Low Temp.)	3/8" X 1/2" ODF	Internal	No	5 Ft.	Straight Thru	No	HFS 1-1/2SZ-01	066526
	2	C (Med. Temp.)	3/8" X 1/2" SAE	External	No	5 Ft.	Angle	No	HFE 2SC-01	062150
	2	C (Med. Temp.)	3/8" X 1/2" ODF	External	No	5 Ft.	Straight Thru	No	HFES 2SC-01	057958
	2	C (Med. Temp.)	3/8" X 1/2" ODF	External	No	5 Ft.	Angle	Yes	HFESC 2SC-01	058122
	2	W45 (MOP)	3/8" X 1/2" ODF	External	No	5 Ft.	Straight Thru	No	HFES 2SW45-01	065740
	2	Z (Low Temp.)	3/8" X 1/2" ODF	External	No	5 Ft.	Straight Thru	No	HFES 2SZ-01	065739
	2	Z (Low Temp.)	3/8" X 1/2" ODF	External	No	5 Ft.	Angle	Yes	HFESC 2SZ-01	058214
	2	C (Med. Temp.)	3/8" X 1/2" ODF	Internal	No	5 Ft.	Straight Thru	No	HFS 2SC-01	066527
	3-1/2	C (Med. Temp.)	3/8" X 1/2" SAE	External	No	5 Ft.	Angle	No	HFE 3-1/2SC-01	058310
	3-1/2	C (Med. Temp.)	3/8" X 1/2" ODF	External	No	5 Ft.	Straight Thru	No	HFES 3-1/2SC-02	065652
	3-1/2	C (Med. Temp.)	3/8" X 1/2" ODF	External	No	5 Ft.	Angle	Yes	HFESC 3-1/2SC-01	058071
	3-1/2	C (Med. Temp.)	3/8" X 1/2" ODF	Internal	No	5 Ft.	Straight Thru	No	HFS 3-1/2SC-01	066530
	3-1/2	C (Med. Temp.)	5/8" X 7/8" ODF	External	No	5 Ft.	Straight Thru	No	HFES 3-1/2SC-01	062151
	3-1/2	W45 (MOP)	1/2" X 5/8" ODF	External	No	5 Ft.	Straight Thru	No	HFES 3-1/2SW45-01	061694
	3-1/2	Z (Low Temp.)	3/8" X 1/2" SAE	External	No	5 Ft.	Angle	No	HFE 3-1/2SZ-01	063493
	3-1/2	Z (Low Temp.)	3/8" X 1/2" ODF	External	No	5 Ft.	Straight Thru	No	HFES 3-1/2SZ-01	063492
	3-1/2	Z (Low Temp.)	3/8" X 1/2" ODF	External	No	5 Ft.	Angle	Yes	HFESC 3-1/2SZ-01	066548
	5	C (Med. Temp.)	3/8" X 1/2" ODF	External	No	5 Ft.	Angle	Yes	HFESC 5SC-02	058220
	5	C (Med. Temp.)	5/8" X 7/8" ODF	External	No	5 Ft.	Straight Thru	No	HFES 5SC-01	066535
	5	W45 (MOP)	3/8" X 1/2" ODF	External	No	5 Ft.	Angle	Yes	HFESC 5SW45-01	058221
	5	W45 (MOP)	5/8" X 7/8" ODF	External	No	5 Ft.	Straight Thru	No	HFES 5SW45-01	064170
	5	Z (Low Temp.)	3/8" X 1/2" ODF	External	No	5 Ft.	Angle	Yes	HFESC 5SZ-01	066549
	5	Z (Low Temp.)	5/8" X 7/8" ODF	External	No	5 Ft.	Straight Thru	No	HFES 5SZ-01	058451
	7	C (Med. Temp.)	5/8" X 7/8" ODF	External	No	5 Ft.	Straight Thru	No	HFES 7SC-02	066536
	7	C (Med. Temp.)	5/8" X 7/8" ODF	External	No	5 Ft.	Angle	Yes	HFESC 7SC-01	065458
	7	W45 (MOP)	5/8" X 7/8" ODF	External	No	5 Ft.	Straight Thru	No	HFES 7SW45-01	066537
	7	W45 (MOP)	5/8" X 7/8" ODF	External	No	5 Ft.	Angle	Yes	HFESC 7SW45-02	066550
	7	Z (Low Temp.)	5/8" X 7/8" ODF	External	No	5 Ft.	Straight Thru	No	HFES 7SZ-01	064291
	7	Z (Low Temp.)	5/8" X 7/8" ODF	External	No	5 Ft.	Angle	Yes	HFESC 7SZ-01	064058
	10	C (Med. Temp.)	5/8" X 7/8" ODF	External	No	5 Ft.	Straight Thru	No	HFES 10SC-02	066538
	10	C (Med. Temp.)	5/8" X 7/8" ODF	External	No	5 Ft.	Angle	Yes	HFESC 10SC-01	064219
	10	W45 (MOP)	5/8" X 7/8" ODF	External	No	5 Ft.	Straight Thru	No	HFES 10SW45-01	064195
10	Z (Low Temp.)	5/8" X 7/8" ODF	External	No	5 Ft.	Straight Thru	No	HFES 10SZ-01	062828	
T (R-290)	1/4	A (Med./Low Temp.)	1/4 X 1/2" ODF	Internal	No	5 Ft.	Angle	No	HFS 1/4TA-01	096830
	1/4	A (Med./Low Temp.)	3/8 X 1/2" ODF	External	No	5 Ft.	Straight Thru	No	HFES 1/4TA-01	096818
	1/4	A (Med./Low Temp.)	3/8 X 1/2" ODF	External	No	5 Ft.	Angle	Yes	HFESC 1/4TA-01	096825
	1/4	A (Med./Low Temp.)	3/8 X 1/2" ODF	Internal	No	5 Ft.	Angle	Yes	HFSC 1/4TA-01	096833
	1/2	A (Med./Low Temp.)	1/4 X 1/2" ODF	Internal	No	5 Ft.	Angle	No	HFS 1/2TA-01	096831
	1/2	A (Med./Low Temp.)	3/8 X 1/2" ODF	External	No	5 Ft.	Straight Thru	No	HFES 1/2TA-01	096817
	1/2	A (Med./Low Temp.)	3/8 X 1/2" ODF	External	No	5 Ft.	Angle	Yes	HFESC 1/2TA-01	096826
	1/2	A (Med./Low Temp.)	3/8 X 1/2" ODF	Internal	No	5 Ft.	Angle	Yes	HFSC 1/2TA-01	096834
	3/4	A (Med./Low Temp.)	1/4 X 1/2" ODF	Internal	No	5 Ft.	Angle	No	HFS 3/4TA-01	096832
	3/4	A (Med./Low Temp.)	3/8 X 1/2" ODF	External	No	5 Ft.	Straight Thru	No	HFES 3/4TA-01	096819
	3/4	A (Med./Low Temp.)	3/8 X 1/2" ODF	External	No	5 Ft.	Angle	Yes	HFESC 3/4TA-01	096827
	1-1/4	A (Med./Low Temp.)	3/8 X 1/2" ODF	External	No	5 Ft.	Straight Thru	No	HFES 1-1/4TA-01	096820
	1-1/4	A (Med./Low Temp.)	3/8 X 1/2" ODF	External	No	5 Ft.	Angle	Yes	HFESC 1-1/4TA-01	096828
	1-3/4	A (Med./Low Temp.)	3/8 X 1/2" ODF	External	No	5 Ft.	Angle	Yes	HFESC 1-3/4TA-01	096829
	2-1/4	A (Med./Low Temp.)	3/8 X 1/2" ODF	External	No	5 Ft.	Straight Thru	Yes	HFES 2-1/4TA-01	096822

System refrigerant code	Capacity (nominal tonnage)	Charge code	Inlet x outlet connection	Equalizer	Bleed	Cap length	Body design	Strainer	Model number	Item number
T (R-290)	3	A (Med./Low Temp.)	3/8 X 1/2" ODF	External	No	5 Ft.	Straight Thru	No	HFES 3TA-01	096823
	5-1/2	A (Med./Low Temp.)	3/8 X 1/2" ODF	External	No	5 Ft.	Straight Thru	No	HFES 5-1/2TA-01	096824

\* Valve capacity is for the first refrigerant listed. To determine the capacity for additional refrigerants listed, consult the nominal capacity tables for interchangeable refrigerants.

**Nominal capacity tables for interchangeable refrigerants in tons (kw): Standard body (1/8 to 5-1/2 tons)**

R-134a	R-12	R-404A / R-507 / R-502	R-22 / R-407C
1/4 (0.9)	1/8 (0.4)	1/8 (0.4)	1/4 (0.9)
1/2 (1.8)	1/4 (0.9)	1/4 (0.9)	1/2 (1.8)
3/4 (2.6)	1/2 (1.8)	1/2 (1.8)	1 (3.5)
1 (3.5)	1 (3.5)	1 (3.5)	1-1/2 (5.3)
1-1/2 (5.3)	1-1/4 (4.4)	1-1/4 (4.4)	2 (7)
1-3/4 (6.2)	1-1/2 (5.3)	1-1/2 (5.3)	2-1/2 (8.8)
2-1/2 (8.8)	2 (7)	2 (7)	3 (10.6)
4 (14.1)	3-1/2 (12.3)	3-1/2 (12.3)	5-1/2 (19.3)

**Nominal capacity tables for interchangeable refrigerants in tons (kw): Extended body (8 to 20 tons)**

R-134a	R-12	R-404A / R-507 / R-502	R-22 / R-407C
6 (21.1)	5 (17.6)	5 (17.6)	8 (28.1)
7-1/2 (26.4)	6 (21.1)	7 (24.6)	10 (35.2)
11 (38.7)	9 (31.7)	10 (35.2)	15 (52.8)
14 (49.2)	12 (42.2)	13 (45.7)	20 (70.3)

All capacities shown are at 100°F condensing, 40°F evaporator temperature. See Extended Capacity Tables for ratings at a wide range of conditions per AHRI standard 750.

**Power assembly model nomenclature - Example: X-26300-BA-1**

Series	System refrigerant code		Charge code	Capillary tube length code
X-26300	B		A	1
X-26300 = Power Element	B = R-448A / R-449A D=R-450A / R-513A F = R-12 H = R-22	M = R-134a S = R-404A T - R-290	A = Med/Low Temp. C = Medium Temp. CA = Heat Pump W(MOP) = Press. Limiting Z = Low Temp.	1 = 5 Ft. 2 = 10 Ft. 3 = 15 Ft.

*HF series power assemblies*

System refrigerant code	Charge code	Cap length	Model number	Item number
B (R-448A/R-449A)	A (Med/Low Temp.)	5 Ft.	X-26300BA-1	066990
D (R-450, R-513A)	A (Med/Low Temp.)	5 Ft.	X-26300DA-1	096859
F (R-12, R-134a)	C (Med Temp.)	5 Ft.	X-26300FC-1	053763
F (R-12, R-134a)	W55 (MOP)	5 Ft.	X-26300FW55-1	063869
F (R-12, R-134a)	W35 (MOP)	5 Ft.	X-26300FW35-1	054798
F (R-12, R-134a)	Z (Low Temp.)	5 Ft.	X-26300FZ-1	053766
H (R-22, R-407C)	C (Med Temp.)	5 Ft.	X-26300HC-1	053764
H (R-22, R-407C)	CA (Heat Pump)	5 Ft.	X-26300HCA-1	057834
H (R-22, R-407C)	W100 (MOP)	5 Ft.	X-26300HW100-1	057764
H (R-22, R-407C)	W35 (MOP)	5 Ft.	X-26300HW35-1	053770
H (R-22, R-407C)	Z (Low Temp.)	5 Ft.	X-26300HZ-1	053767
M (R-134a, R-12)	C (Med Temp.)	5 Ft.	X-26300MC-1	058074
M (R-134a, R-12)	Z (Low Temp.)	5 Ft.	X-26300MZ-1	058076
S (R-404A, R-502 )	C (Med Temp.)	5 Ft.	X-26300SC-1	058083
S (R-404A, R-502 )	W45 (MOP)	5 Ft.	X-26300SW45-1	058085
S (R-404A, R-502 )	Z (Low Temp.)	5 Ft.	X-26300SZ-1	058082
T (R-290)	A (Med/Low Temp.)	5 Ft.	X-26300TA-1	096835

*HF series valve cage kits*

If HF body is stamped HFK then the cage is replaceable.

Cage code	R-12	R-22	R-134a	R-290	R-404a	R-448a / r-449a	R-450a / r-513a	R-507	R-502	Model number	Item number
0	1/8	1/4	1/4	1/4	1/8	1/4	1/5	1/8	1/8	KT-20299-0	064868
1	1/4	1/2	1/2	1/2	1/4	1/2	1/4	1/4	1/4	KT-20299-1	064869
2	1/2	1	3/4	3/4	1/2	1	1/2	1/2	1/2	KT-20299-2	064870
3	1	1-1/2	1	1-1/4	1	1-1/2	3/4	1	1	KT-20299-3	064871
4	1-1/4	2	1-1/2	1-3/4	1-1/4	2	1	1-1/4	1-1/4	KT-20299-4	064872
5	1-1/2	2-1/2	1-3/4	2-1/4	1-1/2	2-1/2	1-1/4	1-1/2	1-1/2	KT-20299-5	064873
6	2	3	2-1/2	3	2	3-1/2	1-3/4	2	2	KT-20299-6	064874
7	3-1/2	5-1/2	4	5-1/2	3-1/2	6	3	3-1/2	3-1/2	KT-20299-7	064875

All capacities shown are at 100°F condensing, 40°F evaporator temperature.  
See Extended Capacity Tables for ratings at a wide range of conditions per ARI standard 750.

*HFK series body kits*

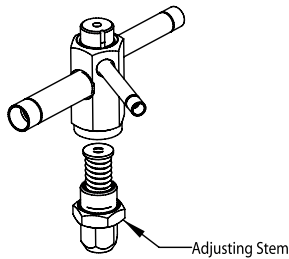
If HF body is stamped HFK then the cage is replaceable.

Valve type	Connections	Body style	External equalizer	Model number	Item number
HFK Body Kit	1/4" X 1/2" SAE	Angle	No	KT-20298-1	064881
HFK Body Kit	3/8" X 1/2" SAE	Angle	No	KT-20298-2	064882
HFKE Body Kit	1/4" X 1/2" SAE	Angle	Yes	KT-20298-3	064883
HFKE Body Kit	3/8" X 1/2" SAE	Angle	Yes	KT-20298-4	064884
HFKSC Body Kit	3/8" X 1/2" ODF	Angle, Removable Strainer	No	KT-20298-5	064885
HFKESC Body Kit	3/8" X 1/2" ODF	Angle, Removable Strainer	Yes	KT-20298-6	064886
HFKS Body Kit	3/8" X 1/2" ODF	Straight Through	No	KT-20298-7	064887
HFKS Body Kit	3/8" X 5/8" ODF	Straight Through	No	KT-20298-8	064888
HFKS Body Kit	1/2" X 5/8" ODF	Straight Through	No	KT-20298-9	064889
HFKS Body Kit	1/2" X 7/8" ODF	Straight Through	No	KT-20298-10	064890
HFKES Body Kit	3/8" X 1/2" ODF	Straight Through	Yes	KT-20298-11	064891
HFKES Body Kit	3/8" X 5/8" ODF	Straight Through	Yes	KT-20298-12	064892
HFKES Body Kit	1/2" X 5/8" ODF	Straight Through	Yes	KT-20298-13	064895
HFKES Body Kit	1/2" X 7/8" ODF	Straight Through	Yes	KT-20298-14	064896

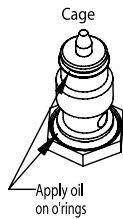
HF series service kits and parts

Description	Model number	Item number
3/8" Inlet Filter Screen	X-11176-1	027385
1/4" Inlet Filter Screen	X-11176-7	048638
SAE Inlet Nut Seal	27676-1	058707
HFSC/HFESC Parts Kit	KT-20264	057686
HFK Cage Insertion Tool	KT-20304	064898
HFK Oil Bottle	Oil Bottle for HFK	064899
HFK Cage Gasket Kit (12 sets)	KT-20305	065203
HFK and HFKE SAE/ODF Kit	KT-20300-5	065135
HF Cage Kit	KT-20301-1	064879

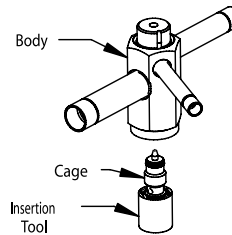
HFK assembly procedure



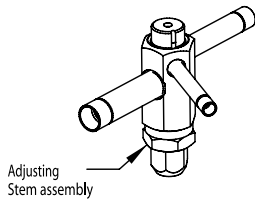
1. Remove adjusting stem assembly from body with 15/16" wrench.



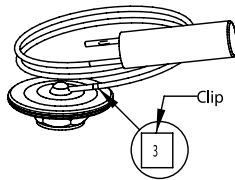
2. Lubricate both o-rings on cage.



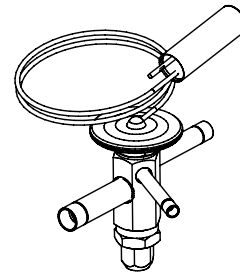
3. Insert cage into body with driver and insertion tool and hand tighten (do not over-tighten).



4. Replace adjustment stem assembly to body and hand tighten. Use the 15/16" wrench to tighten adjustment stem assembly 60° or one wrench flat (300-360 inch lbs. - Do not over-tighten).



5. Attach cage identification clip on power element cap tube.



6. Screw power element to top of valve body and hand tighten. Use the 1" wrench to tighten power element 60° or one wrench flat. (300-360 inch lbs. - Do not over-tighten)



Capacity tables (tons)



TX7-N07 806860

# TX7 Series Thermostatic Expansion Valves

The Copeland TX7 Series is a balanced ported valve designed for air conditioning, heat pumps, close control and industrial process cooling applications. It is ideal for applications requiring a hermetic compact design with stable and accurate control over wide load and evaporation temperature ranges.

## Features

- Hermetic, leak-free construction
- Available for applications up to 47 ton (R-410A)
- Enhanced power element design offers extended valve life
- Laser welded stainless steel power element prevents corrosion
- Bi-directional flow capability allows one valve to control superheat for close-coupled or packaged heat pump applications
- Only available with adjustable superheat
- External equalizer with 1/4 ODF connection
- Balanced port construction

## Specifications

Maximum working pressure ..... 667 psig (46 bar)  
 Refrigerant temperature range..... -13°F to 158°F (-11° to 70°C)  
 Storage temperature..... -22°F to 158°F (-30° to 70°C)  
 Connections..... Copper ODF  
 UL/CUL file number..... SA5312

## Temperature ranges

System refrigerant	Charge	Recommended evaporating temperature range (°f)	Maximum bulb temperature (°f)
R-410A/R-32/R-454B	Z1 MOP 175 psig	-40 to 57	248
R-134a/R-450A/R-513A	M0	-13 to 86	190
R-407C/R-22	N0	-13 to 68	160

Model number nomenclature - Example: TX7-Z16 806816

Series	System refrigerant code	Pressure limiting	Orifice	Unique identifier
TX7	Z	1	6	806816
Hermetic Balanced Port Design	M = R-134a/R450A/R-513A N = R-407C/R-22 Z = R-410A/R-32/R-454B	0 = Without MOP 1 = With MOP	Sizes 3 Through 9	

## TX7 Series Thermostatic Expansion Valves (body style straight thru)

System refrigerant code	Capacity (nominal tonnage)	Pressure limiting	Inlet x outlet connection	Adjustable superheat	Internal check	Equalizer	Bleed	Cap length	Model number	Item number
M (R-134a) *R-450A *R-513A	4	No	1/2" X 5/8" ODF	Yes	No	External	No	5 Ft.	TX7-M03 806824	806824
	5	No	5/8" X 7/8" ODF	Yes	No	External	No	5 Ft.	TX7-M04 806826	806826
	6-1/2	No	5/8" X 7/8" ODF	Yes	No	External	No	5 Ft.	TX7-M05 806828	806828
	10-1/2	No	7/8" X 1-1/8" ODF	Yes	No	External	No	5 Ft.	TX7-M06 806830	806830
	13	No	7/8" X 1-1/8" ODF	Yes	No	External	No	5 Ft.	TX7-M07 806832	806832
	17	No	7/8" X 1-1/8" ODF	Yes	No	External	No	5 Ft.	TX7-M08 806834	806834
	24	No	7/8" X 1-1/8" ODF	Yes	No	External	No	5 Ft.	TX7-M09 806836	806836

TX7 series thermostatic expansion valves (continued) (body style straight thru)

System refrigerant code	Capacity (nominal tonnage)	Pressure limiting	Inlet x outlet connection	Adjustable superheat	Internal check	Equalizer	Bleed	Cap length	Model number	Item number
N (R-407C) *R-22	6-1/2	No	1/2" X 5/8" ODF	Yes	No	External	No	5 Ft.	TX7-N03 806852	806852
	8	No	5/8" X 7/8" ODF	Yes	No	External	No	5 Ft.	TX7-N04 806854	806854
	10	No	5/8" X 7/8" ODF	Yes	No	External	No	5 Ft.	TX7-N05 806856	806856
	16	No	7/8" X 1-1/8" ODF	Yes	No	External	No	5 Ft.	TX7-N06 806858	806858
	20	No	7/8" X 1-1/8" ODF	Yes	No	External	No	5 Ft.	TX7-N07 806860	806860
	26	No	7/8" X 1-1/8" ODF	Yes	No	External	No	5 Ft.	TX7-N08 806862	806862
	37	No	7/8" X 1-1/8" ODF	Yes	No	External	No	5 Ft.	TX7-N09 806864	806864
Z (R-410A) *R-32/R-454B	20	175 (MOP)	7/8" X 1-1/8" ODF	Yes	No	External	No	5 Ft.	TX7-Z16 806816	806816
	25	175 (MOP)	7/8" X 1-1/8" ODF	Yes	No	External	No	5 Ft.	TX7-Z17 806818	806818
	33	175 (MOP)	7/8" X 1-1/8" ODF	Yes	No	External	No	5 Ft.	TX7-Z18 806820	806820
	47	175 (MOP)	7/8" X 1-1/8" ODF	Yes	No	External	No	5 Ft.	TX7-Z19 806822	806822

\* Valve capacity is for the first refrigerant listed. To determine the capacity for additional refrigerants listed, consult the Nominal Capacity Tables for Interchangeable Refrigerants.

Nominal capacity tables for interchangeable refrigerants in tons (kw)

Orifice size	R-134A	R-450A	R-513A	R-407C	R-22	R-410A	R-32	R-454B
3	4 (14.7)	4 (13.7)	3-3/4 (13.1)	6-1/2 (22.6)	7 (24.2)	--	--	--
4	5 (18.3)	5 (17.0)	4-1/2 (16.2)	8 (28.1)	8-1/2 (30.0)	--	--	--
5	6-1/2 (22.4)	6 (20.9)	5-1/2 (19.9)	10 (34.4)	10-1/2 (36.8)	--	--	--
6	10-1/2 (37.0)	10 (34.5)	9-1/2 (32.9)	16 (56.9)	17 (60.8)	20 (71.7)	30 (105.0)	22 (77.4)
7	13 (45.6)	12 (42.5)	11-1/2 (40.5)	20 (70.1)	21 (74.9)	25 (88.3)	37 (129.4)	27 (95)
8	17 (60.1)	16 (55.9)	15 (53.3)	26 (92.3)	28 (98.6)	33 (116.3)	48 (170.4)	35 (123.1)
9	24 (84.2)	22 (78.4)	21 (74.7)	37 (129.3)	40 (138.2)	47 (163.0)	68 (238.8)	50 (175.8)

All capacities shown are at 100°F condensing, 40°F evaporator temperature. See Extended Capacity Tables for ratings at a wide range of conditions per AHRI standard 750.



TRAE+20HC-01



TRAE 50HC-02

# TRAE Series Thermostatic Expansion Valves

The TRAE Series is a large capacity valve designed for refrigeration, air conditioning, heat pump and chiller applications.

## Features

- Suitable for heat pump bi-directional applications
- External superheat adjustment
- Integral body with straight thru connections
- Balanced port construction
- Solid copper connections
- Large diaphragm provides superior stability
- Replaceable power element and cage assembly for full serviceability on TRAE+ models
- Stainless steel power element for TRAE+
- Permanent inlet strainer

## Specifications

Maximum working pressure .....450 psig (31 bar)  
 UR/CUR file number.....SA5312  
 Canadian CRN.....0C21506.513467890YTN

### Model number nomenclature - Example: TRAE+ 30HC-01

Series	Equalizer	Replaceable Components	Capacity	System Refrigerant code	Charge code	Sequential identifier	Customer special	Pack type
TRA	E	+	30	H	C	-01		
Double Balanced Port Design	E = External 1/4" SAE	Cage and Power Assembly	Nominal Rating in Tons	F = R-12 H = R-22 M = R-134a N = R-407C P = R-507 R = R-502 S = R-404A	AA = Wide Range C = Medium Temp. CA = Heat Pump W(MOP) = Press. Limiting Z = Low Temp.	-01 Thru -999	G = Customer Special  (Omit for Standard)	B1 = Bulk Pack  (Omit for Individual Pack)

### TRAE Series Thermostatic Expansion Valves (body style straight thru)

Refrigerant code	Capacity (nominal tonnage)	Charge code	Inlet x outlet connection	Cap length	Model number	Item number
H (R-22) *R-407C	10	C (Med. Temp.)	5/8" X 7/8" ODF	5 Ft.	TRAE+ 10HC-01	062718
	10	C (Med. Temp.)	7/8" X 1-1/8" ODF	15 Ft.	TRAE+ 10HC-02	063100
	10	CA (Heat Pump)	5/8" X 7/8" ODF	10 Ft.	TRAE+ 10HCA-05	063138
	10	CA (Heat Pump)	7/8" X 1-1/8" ODF	10 Ft.	TRAE+ 10HCA-07	063554
	15	C (Med. Temp.)	7/8" X 1-1/8" ODF	10 Ft.	TRAE+ 15HC-02	062721
	15	CA (Heat Pump)	5/8" X 7/8" ODF	10 Ft.	TRAE+ 15HCA-05	063510
	15	CA (Heat Pump)	7/8" X 1-1/8" ODF	10 Ft.	TRAE+ 15HCA-03	062722
	15	W100 (MOP)	5/8" X 7/8" ODF	5 Ft.	TRAE+ 15HW100-02	063103
	15	W100 (MOP)	7/8" X 1-1/8" ODF	10 Ft.	TRAE+ 15HW100-01	062723
	20	C (Med. Temp.)	7/8" X 1-1/8" ODF	10 Ft.	TRAE+ 20HC-01	062724
	20	C (Med. Temp.)	7/8" X 1-3/8" ODF	10 Ft.	TRAE+ 20HC-03	063650
	20	CA (Heat Pump)	7/8" X 1-1/8" ODF	10 Ft.	TRAE+ 20HCA-04	062725

Refrigerant code	Capacity (nominal tonnage)	Charge code	Inlet x outlet connection	Cap length	Model number	Item number
H (R-22) *R-407C	20	W100 (MOP)	7/8" X 1-1/8" ODF	10 Ft.	TRAE+ 20HW100-01	062726
	20	W90 (MOP)	7/8" X 1-1/8" ODF	15 Ft.	TRAE+ 20HW90-05	064018
	30	C (Med. Temp.)	7/8" X 1-1/8" ODF	10 Ft.	TRAE+ 30HC-03	062727
	30	C (Med. Temp.)	1-1/8" X 1-3/8" ODF	10 Ft.	TRAE+ 30HC-04	062728
	30	CA (Heat Pump)	1-1/8" X 1-3/8" ODF	10 Ft.	TRAE+ 30HCA-07	062730
	30	W100 (MOP)	7/8" X 1-3/8" ODF	5 Ft.	TRAE+ 30HW100-04	063425
	40	C (Med. Temp.)	1-1/8" X 1-3/8" ODF	10 Ft.	TRAE+ 40HC-02	062733
	40	C (Med. Temp.)	1-1/8" X 1-3/8" ODF	15 Ft.	TRAE+ 40HC-03	063153
	40	CA (Heat Pump)	1-1/8" X 1-3/8" ODF	10 Ft.	TRAE+ 40HCA-04	062734
	50	C (Med. Temp.)	1-1/8" X 1-3/8" ODF	10 Ft.	TRAE 50HC-02	061700
	60	C (Med. Temp.)	1-1/8" X 1-3/8" ODF	10 Ft.	TRAE 60HC-03	061865
	60	C (Med. Temp.)	1-3/8" X 1-3/8" ODF	20 Ft.	TRAE 60HC-01	058657
	70	C (Med. Temp.)	1-1/8" X 1-3/8" ODF	10 Ft.	TRAE 70HC-03	061866
M (R-134a) *R-12	22	C (Med. Temp.)	7/8" X 1-1/8" ODF	10 Ft.	TRAE+ 22MC-02	063462
	30	C (Med. Temp.)	1-1/8" X 1-3/8" ODF	10 Ft.	TRAE+ 30MC-01	064001
	40	C (Med. Temp.)	1-1/8" X 1-3/8" ODF	15 Ft.	TRAE 40MC-01	063941
S (R-404A) *R-502 *R-507	14	C (Med. Temp.)	1-1/8" X 1-1/8" ODF	10 Ft.	TRAE+ 14SC-01	064407
	20	C (Med. Temp.)	7/8" X 1-1/8" ODF	10 Ft.	TRAE+ 20SC-02	063461
	20	Z (Low Temp.)	5/8" X 7/8" ODF	10 Ft.	TRAE+ 20SZ-01	064923
	35	C (Med. Temp.)	1-1/8" X 1-3/8" ODF	10 Ft.	TRAE 35SC-01	064217

\* Valve capacity is for the first refrigerant listed. To determine the capacity for additional refrigerants listed, consult the Nominal Capacity Tables for Interchangeable Refrigerants.

**Nominal capacity tables for interchangeable refrigerants in tons (kw): TRAE+ 10-40 ton**

R-134a	R-12	R-404A / R-502	R-507	R-22 / R-407C
9 (31.7)	7-1/2 (26.4)	8 (28.1)	8 (28.1)	10 (35.2)
13 (45.7)	10 (35.2)	12 (42.2)	12 (42.2)	15 (52.8)
14 (49.2)	12 (42.2)	14 (49.2)	14 (49.2)	20 (70.3)
22 (77.4)	18 (63.3)	20 (70.3)	20 (70.3)	30 (105.5)
30 (105.5)	25 (87.9)	30 (105.5)	28 (98.5)	40 (140.8)

**Nominal capacity tables for interchangeable refrigerants in tons (kw): TRAE 40-70 ton**

R-134a	R-12	R-404A / R-507 / R-502	R-22 / R-407C
40 (140.8)	30 (105.5)	35 (123.1)	50 (175.8)
45 (158.3)	35 (123.1)	40 (140.8)	60 (211.0)
50 (175.8)	40 (140.8)	50 (175.8)	70 (246.2)

All capacities shown are at 100°F condensing, 40°F evaporator temperature. See Extended Capacity Tables for ratings at a wide range of conditions per AHRI standard 750.

**TRAE+ power assembly model nomenclature - Example: X-28458HCA-2**

Print reference	System refrigerant code	Charge code	Capillary tube length code
X-28458	H	CA	2
X-28458 = Drawing Number	H = R-22 M = R-134a R = R-502 S = R-404A	C = Medium Temp. CA = Heat Pump G(MOP) = Press. Limiting W(MOP) = Press. Limiting Z = Low Temp.	1 = 5 Ft. 2 = 10 Ft. 3 = 15 Ft.

**TRAE+ power assemblies**

Print reference	System refrigerant code	Charge code	Cap length	Model number	Item number
X-28458	H (R-22, R-407C)	CA (Heat Pump)	10 Ft.	X-28458HCA-2	063414
X-28458	H (R-22, R-407C)	W100 (MOP)	10 Ft.	X-28458HW100-2	063416
X-28458	S (R-404A, R-502, R-507)	C (Med. Temp.)	10 Ft.	X-28458SC-2	065439
X-28458	M (R-134a)	C (Medium Temp.)	15 Ft.	X-28458MC-3	063593

**TRAE+ cage kits**

Cage kits are cross referenced by capacity and tonnage in the table below. Each cage kit consists of a replacement cage and cage removal wrench. In addition, the cage removal wrench (KT-20294) can be ordered as a separate item.

Nominal capacity - tons			Model number	Item number
R-22	R-12 / R-134a	R-507 / R-404A / R-502		
15	13	12	KT-20290	063388
20	14	14	KT-20291	063389
30	22	20	KT-20292	063390
40	30	30	KT-20293	063391

Capacities shown are at 100° F condensing and 40° F evaporator temperature. See Extended Capacity Tables for ratings at a wide range of conditions.

**TRAE+ parts list**

Description	Model number	Item number
TRAE Series Cage Wrench	KT-20294	063392
Nut Seal	27676-1	058707



Capacity tables (tons)



# T-Series Take-Apart Thermostatic Expansion Valves

T-Series take-apart valves with adjustable superheat and replaceable, interchangeable components are ideal for air conditioning, heat pump, and refrigeration applications.

## Features

- Take-apart construction for easy field service
- External superheat adjustment
- Bi-directional capability
- Stainless steel power assembly up to 18 tons
- Interchangeable replaceable cages, body flanges, power assemblies
- 1/4 to 100 Tons Capacity

## Specifications

Maximum working pressure ..... 450 psig (31 bar)  
 Torque bolts ..... 300 In. Lbs

### Model number nomenclature - Example: TCLE 3FC-03

Series	Type	Navy	Equalizer	Bleed hole	Capacity	System refrigerant code	Charge code	Sequential identifier	Customer special	Pack type
t	CL		E		3	F	C	-03		
Take-Apart Adjustable Superheat	CL, JL, JR = Small Capacity (1/2 to 18 Tons R-22)  ER, IR, HR, MR = Large Capacity, Balanced Port (22 to 100 Tons R-22)	N= Navy  (Omit for Standard)	E = External  (Omit for Internal and Omit on Externally Equalized TCLN, TER, THR, TIR, TMR Models)	B = Bleed Hole  (Omit for No Bleed Hole)	Nominal Rating in Tons	F = R-12 H = R-22 M = R-134a N = R-407C P = R-507 R = R-502 S = R-404A	AA = Wide Range C = Medium Temp. CA = Heat Pump W(MOP) = Press. Limiting Z = Low Temp.	-01 Thru -999	G = Cust. Special  (Omit for Standard)	B1 = Bulk Pack  (Omit for Individual Pack)

### Step 1: Select small capacity cage kit

#### T-series small capacity cage kits

Valve type	Nominal capacity - tons							Model number	Item number
	R-12	R-134a	R-22	R-404a / R-507	R-407c	R-502	Equalizer		
TCL TCLE	1/4	1/4	1/2	1/4	1/2	1/4	Internal	X-22440-B1A	037034
	1/4	1/4	1/2	1/4	1/2	1/4	External	X-22440-B1B	037035
	1/2	3/4	1	1/2	1	1/2	Internal	X-22440-B2A	037036
	1/2	3/4	1	1/2	1	1/2	External	X-22440-B2B	037037
	1	1-1/5	2	1	2	1	Internal	X-22440-B3A	037038
	1	1-1/2	2	1	2	1	External	X-22440-B3B	037039
	2	2-1/2	3	2	3	2	Internal	X-22440-B4A	037040
	2	2-1/2	3	2	3	2	External	X-22440-B4B	037041
	3	3-1/2	5	3	5	3	External	X-22440-B5B	037043
	4	5-1/2	7-1/2	4-1/2	7-1/2	4-1/2	External	X-22440-B6B	037045
	6-1/2	7-1/2	10	7	10	7	External	X-22440-B7B	037047
7-1/2	9	12	8	12	8	External	X-22440-B8B	037049	
TJLE	7	9	11	7	11	7	External	XC-724-B4B	093343
	8	11	14	9	14	9	External	XC-724-B5B	038699
TJR	8	11	14	9	14	9	External	X-11873-B4B	088837
	11	13	18	12	18	12	External	X-11873-B5B	089058

Gasket strip X13455-1 (ITEM NUMBER 027579) replaces all older T-Series Gasket kits.

**Step 2: Select small capacity flange**

**T-3**

Valve type	Configuration	Inlet connection	Outlet connection	Model number	Item number
TCL,TCLE	Angle	3/8" SAE	1/2" SAE	C-500-4	056932
TCL,TCLE	Angle	1/2" SAE	5/8" SAE	C-500-6	056294
TCL,TCLE	Angle	3/8" ODF	1/2" ODF	C-501-4	065527
TCL,TCLE	Angle	3/8" ODF	5/8" ODF	C-501-5	065748
TCL,TCLE	Angle	1/2" ODF	5/8" ODF	C-501-7	065861
TCL,TCLE	Angle	5/8" ODF or 7/8" ODM	7/8" ODF or 1-1/8" ODM	A576	027764
TCL,TCLE	Straight Thru	3/8" SAE	1/2" SAE	X-6669-4	051176
TCL,TCLE	Straight Thru	3/8" SAE	5/8" SAE	X-6669-1	050563
TCL,TCLE	Straight Thru	1/2" SAE	1/2" SAE	X-6669-5	083378
TCL,TCLE	Straight Thru	1/2" SAE	5/8" SAE	X-6669-2	050842
TCL,TCLE	Straight Thru	3/8" ODF	1/2" ODF	9761-5	027769
TCL,TCLE	Straight Thru	3/8" ODF	5/8" ODF	9761-3	027771
TCL,TCLE	Straight Thru	1/2" ODF	1/2" ODF	9761-9	027766
TCL,TCLE	Straight Thru	1/2" ODF	5/8" ODF	9761-4	027268
TCL,TCLE	Straight Thru	1/2" ODF	7/8" ODF	9761-2	027770
TCL,TCLE	Straight Thru	5/8" ODF	5/8" ODF	X-6346-16	044733
TCL,TCLE	Straight Thru	5/8" ODF	7/8" ODF	X-6346-17	044846
TCL,TCLE	Straight Thru	5/8" ODF	1-1/8" ODF	X-6346-18	094038
TCL,TCLE	Straight Thru	7/8" ODF	1-1/8" ODF	X-6346-34	071757
TJLE	Angle	5/8" ODF or 7/8" ODM	7/8" ODF or 1-1/8" ODM	B504	044984
TJLE	Straight Thru	5/8" ODF	1-1/8" ODF	X-6347-2	094289
TJLE	Straight Thru	7/8" ODF	1-1/8" ODF	X-6347-6	057210
TJLE	Straight Thru	7/8" ODF	1-3/8" ODF	X-6347-7	057323
TJR	Angle	7/8" ODF or 1-1/8" ODM	7/8" ODF or 1-1/8" ODM	10331	029411
TJR	Straight Thru	7/8" ODF or 1-1/8" ODM	7/8" ODF or 1-1/8" ODM	10332	032988

**Step 3: Select power assembly**

Power assembly model nomenclature - Example: XB-1019FC-1A

Print reference	System refrigerant code	Charge code	Capillary tube length code	Equalizer
xB-1019	F	C	1	A
XB-1019 = Drawing Number	F = R-12 H = R-22 M = R-134a N = R-407C P = R-507 R = R-502 S = R-404A	A = Medium & Low Temp. AA = Wide Range C = Medium Temp. CA = Heat Pump W(MOP) = Press. Limiting Z = Low Temp.	1 = 5 Ft. 2 = 10 Ft. 3 = 15 Ft.	A = Internal B = External

**T-series small power assemblies**

Valve type	System refrigerant code	Charge code	Cap length	Equalizer	Model number	Item number
TCL, TCLE, TJLE, TJR	F (R-12)	W15 (MOP)	5 Ft.	External	XB-1019FW15-1B	077063
	F (R-12)	W35 (MOP)	5 Ft.	External	XB-1019FW35-1B	079346
	F (R-12)	W55 (MOP)	5 Ft.	External	XB-1019FW55-1B	057432
	F (R-12)	C (Med. Temp.)	10 Ft.	Internal	XB-1019FC-2A	032374
	F (R-12)	C (Med. Temp.)	10 Ft.	External	XB-1019FC-2B	052954
	F (R-12)	C (Med. Temp.)	5 Ft.	Internal	XB-1019FC-1A	052951
	F (R-12)	C (Med. Temp.)	5 Ft.	External	XB-1019FC-1B	049881
	H (R-22)	W100 (MOP)	10 Ft.	External	XB-1019HW100-2B	062658
H (R-22)	W100 (MOP)	5 Ft.	External	XB-1019HW100-1B	062437	

T-series small power assemblies (continued)

Valve type	System refrigerant code	Charge code	Cap length	Equalizer	Model number	Item number
TCL, TCLE, TJLE, TJR	H (R-22)	W55 (MOP)	5 Ft.	External	XB-1019HW55-1B	039152
	H (R-22)	W65 (MOP)	5 Ft.	External	XB-1019HW65-1B	089445
	H (R-22)	CA (Heat Pump)	5 Ft.	External	XB-1019HCA-1B	056039
	H (R-22)	Z (Low Temp.)	10 Ft.	External	XB-1019HZ-2B	054105
	H (R-22)	Z (Low Temp.)	5 Ft.	External	XB-1019HZ-1B	040568
	H (R-22)	C (Med. Temp.)	10 Ft.	External	XB-1019HC-2B	054390
	H (R-22)	C (Med. Temp.)	20 Ft.	External	XB-1019HW-4B	055703
	H (R-22)	C (Med. Temp.)	5 Ft.	External	XB-1019HC-1B	053416
	M (R-134a)	W55 (MOP)	5 Ft.	External	XB-1019MW55-1B	057370
	M (R-134a)	Z (Low Temp.)	5 Ft.	External	XB-1019MZ-1B	061946
	M (R-134a)	C (Med. Temp.)	10 Ft.	External	XB-1019MC-2B	059548
	M (R-134a)	C (Med. Temp.)	5 Ft.	External	XB-1019MC-1B	057878
	N (R-407C)	W100 (MOP)	5 Ft.	External	XB-1019NW100-1B	063069
	N (R-407C)	C (Med. Temp.)	5 Ft.	External	XB-1019NC-1B	064837
	P (R-507)	W40 (MOP)	5 Ft.	External	XB-1019PW40-1B	064200
	P (R-507)	Z (Low Temp.)	5 Ft.	External	XB-1019PZ-1B	061951
	P (R-507)	C (Med. Temp.)	5 Ft.	External	XB-1019PC-1B	061949
	R (R-502)	W35 (MOP)	5 Ft.	External	XB-1019RW35-1B	063644
	R (R-502)	W45 (MOP)	5 Ft.	External	XB-1019RW45-1B	055881
	R (R-502)	W65 (MOP)	5 Ft.	External	XB-1019RW65-1B	063114
	R (R-502)	Z (Low Temp.)	10 Ft.	External	XB-1019RZ-2B	047358
	R (R-502)	Z (Low Temp.)	5 Ft.	External	XB-1019RZ-1B	046474
	R (R-502)	C (Med. Temp.)	10 Ft.	External	XB-1019RC-2B	054415
	R (R-502)	C (Med. Temp.)	5 Ft.	External	XB-1019RC-1B	052955
	S (R-404A)	W40 (MOP)	5 Ft.	External	XB-1019SW40-1B	059130
	S (R-404A)	W65 (MOP)	5 Ft.	External	XB-1019SW65-1B	063541
S (R-404A)	Z (Low Temp.)	10 Ft.	External	XB-1019SZ-2B	061948	
S (R-404A)	C (Med. Temp.)	5 Ft.	External	XB-1019SC-1B	059189	

Step 1: Select large capacity cage kit

T-series large capacity cage kits

Valve type	Nominal capacity - tons							Model number	Item number
	R-12	R-134a	R-22	R-404a / r-507	R-407c	R-502	Equalizer		
TER	13	16	22	14	22	14	External	X-9117-B6B	077896
TER	15	19	26	16	26	16	External	X-9117-B7B	078117
TER	20	25	35	21	35	21	External	X-9117-B8B	071155
TER	25	31	45	27	45	27	External	X-9117-B9B	029429
TIR	35	45	55	37	55	37	External	X-9166-B10B	070738
THR	35	45	55	37	55	37	External	X-9144-B10B	071238
THR	45	55	75	48	70	48	External	X-9144-B11B	020846
THR	55	68	85	60	85	60	External	X-9144-B13B	021067
TMR	55	68	100	60	100	—	External	X-9144-B14B	065123



Capacity tables (tons)

**Step 2: Select large capacity flange**

*T-series large capacity flanges*

Valve type	Configuration	Inlet connection	Outlet connection	Model number	Item number
TER	Angle	7/8" ODF or 1-1/8" ODM	7/8" ODF or 1-1/8" ODM	9153	027919
TER	Straight Thru	7/8" ODF or 1-1/8" ODM	7/8" ODF or 1-1/8" ODM	9152	027918
TIR	Angle	7/8" ODF or 1-1/8" ODM	7/8" ODF or 1-1/8" ODM	9151	027926
TIR	Straight Thru	7/8" ODF or 1-1/8" ODM	7/8" ODF or 1-1/8" ODM	9150	028849
THR	Angle	1-1/8" ODM	1-1/8" ODM	9149	028030
THR	Straight Thru	1-1/8" ODM	1-1/8" ODM	9148	028032
TMR	Angle	1-1/8" ODM	1-1/8" ODM	9149-1	065124

**Step 3: Select power assembly**

*Power assembly model nomenclature - Example: XB-1019FC-1A*

Print reference	System refrigerant code	Charge code	Capillary tube length code	Equalizer
XB-1019	F	C	1	A
XB-1019 = Drawing Number	F = R-12 H = R-22 M = R-134a N = R-407C P = R-507 R = R-502 S = R-404A	C = Medium Temp. CA = Heat Pump W(MOP) = Press. Limiting Z = Low Temp.	1 = 5 Ft. 2 = 10 Ft. 3 = 15 Ft.	A = Internal B = External

*T-series large power assemblies*

Valve type	System refrigerant code	Charge code	Capillary tube	Equalizer	Model number	Item number
TER, TIR, THR, TMR	F (R-12)	C (Med. Temp.)	10 Ft.	External	XC-726FC-2B	052957
	H (R-22)	W100 (MOP)	10 Ft.	External	XC-726HW100-2B	036750
	H (R-22)	W35 (MOP)	10 Ft.	External	XC-726HW35-2B	024511
	H (R-22)	W65 (MOP)	10 Ft.	External	XC-726HW65-2B	025011
	H (R-22)	CA (Heat Pump)	10Ft.	External	XC-726HCA-2B	059333
	H (R-22)	Z (Low Temp.)	10 Ft.	External	XC-726HZ-2B	040569
	H (R-22)	C (Med. Temp.)	10 Ft.	External	XC-726HC-2B	056421
	M (R-134a)	M55 (MOP)	10 Ft.	External	XC-726MW55-2B	057372
	M (R-134a)	C (Med. Temp.)	10 Ft.	External	XC-726MC-2B	057235
	R (R-502)	W15 (MOP)	10 Ft.	External	XC-726RW15-2B	023351
	R (R-502)	W35 (MOP)	10 Ft.	External	XC-726RW35-2B	070866
	R (R-502)	W65 (MOP)	10 Ft.	External	XC-726RW65-2B	071421
	R (R-502)	Z (Low Temp.)	10 Ft.	External	XC-726RZ-2B	046692
	R (R-502)	C (Med. Temp.)	10 Ft.	External	XC-726RC-2B	052958
	S (R-404A)	W40 (MOP)	10 Ft.	External	XC-726SW40-2B	063127
	S (R-404A)	W65 (MOP)	10 Ft.	External	XC-726SW65-2B	061692
TCLE, TJLE, TJRE	S (R-404A)	Z (Low Temp.)	10 Ft.	External	XC-726SZ-2B	063974
	S (R-404A)	C (Med. Temp.)	10 Ft.	External	XC-726SC-2B	062303
	R-12	Rapid Response	5 Ft.	External	X-8019FWS-1B	031654
	R-22	Rapid Response	10 Ft.	External	X-8019HWS-2B	055873
	R-22	Rapid Response	5 Ft.	External	X-8019HWS-1B	055652
	R-502	Rapid Response	10 Ft.	External	X-8019RWS-2B	042426
	R-502	Rapid Response	5 Ft.	Internal	X-8019RWS-1A	032131

NOTE: Nominal capacities shown here are based on 40°F evaporator temperature and 100°F vapor-free liquid refrigerant entering the valve. R-12 and R-134a rated at 60 PSID. All other refrigerants rated at 100 PSID.

T-Series Thermostatic Expansion Valves (less flange)

System refrigerant code	Capacity (nominal tonnage)	Charge code	Equalizer	Cap length	Model number	Item number
F (R-12)	1/2	C (Med. Temp.)	External	5 Ft.	TCLE 1/2FC-01	054413
	2	C (Med. Temp.)	External	5 Ft.	TCLE 2FC-03	052941
	3	C (Med. Temp.)	External	5 Ft.	TCLE 3FC-03	052942
	4	C (Med. Temp.)	External	5 Ft.	TCLE 4FC-03	052943
	6-1/2	C (Med. Temp.)	External	5 Ft.	TCLE 6-1/2FC-02	052944
	7-1/2	C (Med. Temp.)	External	5 Ft.	TCLE 7-1/2FC-03	052945
H (R-22)	25	C (Med. Temp.)	External	10 Ft.	TER 25FC-01	055111
	1	C (Med. Temp.)	External	5 Ft.	TCLE 1HC-01	062884
	2	C (Med. Temp.)	External	5 Ft.	TCLE 2HC-03	061724
	3	C (Med. Temp.)	External	5 Ft.	TCLE 3HC-05	054395
	3	W100 (MOP)	External	5 Ft.	TCLE 3HW100-05	089943
	5	C (Med. Temp.)	External	5 Ft.	TCLE 5HC-02	054399
	7-1/2	C (Med. Temp.)	External	5 Ft.	TCLE 7-1/2HC-02	054401
	7-1/2	W100 (MOP)	External	5 Ft.	TCLE 7-1/2HW100-08	054079
	10	C (Med. Temp.)	External	5 Ft.	TCLE 10HC-03	054404
	10	W 100 (MOP)	External	5 Ft.	TCLE 10HW100-07	059076
	12	C (Med. Temp.)	External	5 Ft.	TCLE 12HC-05	060854
	14	C (Med. Temp.)	External	5 Ft.	TJLE 14HC-04	060856
	14	C (Med. Temp.)	External	5 Ft.	TJRE 14HC-02	060857
	18	C (Med. Temp.)	External	5 Ft.	TJRE 18HC-05	060858
	22	C (Med. Temp.)	External	10 Ft.	TER 22HC-04	061673
	22	W100 MOP	External	10 Ft.	TER 22HW100-04	058582
	26	C (Med. Temp.)	External	10 Ft.	TER 26HC-05	061674
	35	C (Med. Temp.)	External	10 Ft.	TER 35HC-04	061675
	35	W 100 (MOP)	External	10 Ft.	TER 35HW100-02	058038
	45	C (Med. Temp.)	External	10 Ft.	TER 45HC-05	061676
75	C (Med. Temp.)	External	10 Ft.	THR 75HC-04	064961	
100	C (Med. Temp.)	External	10 Ft.	THR 100HC-03	062036	
100	W 100 (MOP)	External	10 Ft.	THR 100HW100-07	052912	
	3	C (Med. Temp.)	External	5 Ft.	TCLE 3RC-01	055501
	8	C (Med. Temp.)	External	5 Ft.	TCLE 8RC-01	063501
	14	C (Med. Temp.)	External	10 Ft.	TER 14RC-01	060788

T-series parts list

Valve type	Description	Model number	Item number
TLE	Packing Nut Wrench	E-642	039862
LCL, TLE, ZZ	Take-Apart Gasket Set	X-13455-1	027579
T-Series	Superheat Plug	X-28124-1	058336
TCL, TLE	Replacement Capscrews, 10 Pcs of Screw # PS-286-5	KT-30021	054569
TJR, TER	Replacement Capscrews 10 Pcs of Screw # PS-259	KT-30023	054571
TMR	Straight Thru	9148-1	065125



TLE 3HW75-01

# TLE Series Thermostatic Expansion Valves

The TLE Series is designed for air conditioning, heat pumps, transportation and commercial refrigeration. Take-apart construction improves serviceability with replaceable/interchangeable parts.

## Features

- Stainless steel power element eliminates corrosion and prevents valve failure
- Non-adjustable superheat
- Bi-directional capability for heat pump applications (external equalizer required)
- Take-Apart construction for easy field service
- Interchangeable capacity cages, power assemblies and flanges available

## Specifications

Maximum working pressure ..... 680 psig (47 bar)  
 Capscrew torque ..... 300 In. lbs.

### Model number nomenclature - Example: TLE 5HW-01

Series	Equalizer	Bleed hole	Capacity	System refrigerant code	Charge code	Sequential identifier	Customer special	Pack type
TL	E		5	H	W	-01		
Take-Apart	E = External 1/4" SAE Standard 1/4" ODF Available  (Omit for Internal)	B = Bleed Hole  (Omit for no Bleed Hole)	Nominal Rating in Tons	F = R-12 H = R-22 M = R-134a N = R-407C P = R-507 R = R-502 S = R-404A	AA = Wide Range C or W = Medium Temp. CA = Heat Pump W(MOP) = Press. Limiting Z = Low Temp.	-01 Thru -999	G = Customer Special  (Omit for Standard)	B1 = Bulk Pack  (Omit for Individual pack)

### TLE Series Thermostatic Expansion Valves

System refrigerant code	Capacity (nominal tonnage)	Charge code	Inlet x outlet connection	Equalizer	Bleed	Cap length	Model number	Item number
H (R-22) *R-407C	3	W (Med. Temp.)	Valve Less Flange	External	No	5 Ft.	TLE 3HW-01	041734
	3	W100 (MOP)	Valve Less Flange	External	No	5 Ft.	TLE 3HW100-02	053363
	3	W75 (MOP)	5/8" X 7/8" ODF (Straight-Thru)	External	No	5 Ft.	TLE 3HW75-01	041931
	5	W (Med. Temp.)	Valve Less Flange	External	No	5 Ft.	TLE 5HW-01	054793
	10	W (Med. Temp.)	Valve Less Flange	External	No	5 Ft.	TLE 10HW-01	055125

### TLE series power assembly nomenclature - Example: XB-1033HC-1B

Print reference	System refrigerant code	Charge code	Capillary tube length code	Equalizer
XB-1033	H	C	1	B
XB-1033 = Drawing Number	F = R-12 H = R-22 M = R-134a N = R-407C P = R-507 R = R-502 S = R-404A	C=Medium Temp. CA = Heat Pump W(MOP) = Press. Limiting Z = Low Temp.	1 = 5 Ft. 2 = 10 Ft. 3 = 15 Ft. 15 = 30 In.	A = Internal B = External

### TLE series power assemblies

Print reference	System refrigerant code	Charge code	Cap length	Equalizer	Model number	Item number
XB-1033	H (R-22)	C (Med. Temp.)	5 Ft.	External	XB-1033HC-1B	061760
XB-1033	H (R-22)	W (Wide Range)	30 In.	Internal	XB-1033HW-15A	077201
XB-1033	H (R-22)	W100 (MOP)	30 In.	External	XB-1033HW100-15B	095534
XB-1033	H (R-22)	W100 (MOP)	5 Ft.	External	XB-1033HW100-1B	095813
XB-1033	H (R-22)	W90 (MOP)	5 Ft.	External	XB-1033HW90-1B	090082

*TLE series cage kits*

R-12	R-134A	R-22 / R-407C	R-404a / R-507 / R-502	Model number	Item number
1/4	1/4	1/2	1/4	X-22517-B1B	041551
2	2-1/2	3	2	X-22517-B4B	041558
3	3-1/2	5	3	X-22517-B5B	041562
4	5-1/2	7-1/2	4-1/2	X-22517-B6B	041564
6-1/2	7-1/2	10	7	X-22517-B7B	041566

Capacities shown are at 100°F condensing and 40°F evaporator temperature. See Extended Capacity Tables for ratings at a wide range of conditions.

*TLE series flanges*

Configuration	Inlet connection	Outlet connection	Model number	Item number
Angle	1/2" ODF	5/8" ODF	C-501-7	065861
Angle	1/2" SAE	5/8" SAE	C-500-6	056294
Angle	3/8" ODF	1/2" ODF	C-501-4	065527
Angle	3/8" ODF	5/8" ODF	C-501-5	065748
Angle	3/8" SAE	1/2" SAE	C-500-4	056932
Straight Thru	1/2" ODF	1/2" ODF	9761-9	027766
Straight Thru	1/2" ODF	5/8" ODF	9761-4	027268
Straight Thru	1/2" ODF	7/8" ODF	9761-2	027770
Straight Thru	1/2" SAE	1/2" SAE	X-6669-5	083378
Straight Thru	1/2" SAE	5/8" SAE	X-6669-2	050842
Straight Thru	3/8" ODF	1/2" ODF	9761-5	027769
Straight Thru	3/8" ODF	5/8" ODF	9761-3	027771
Straight Thru	3/8" SAE	1/2" SAE	X-6669-4	051176
Straight Thru	3/8" SAE	5/8" SAE	X-6669-1	050563
Straight Thru	5/8" ODF	1-1/8" ODF	X-6346-18	094038
Straight Thru	5/8" ODF	5/8" ODF	X-6346-16	044733
Straight Thru	5/8" ODF	7/8" ODF	X-6346-17	044846
Straight Thru	7/8" ODF	1-1/8" ODF	X-6346-34	071757



TIE SW 802460

# TI Series Thermostatic Expansion Valves

The TI Series has interchangeable cages capable of changing valve capacity in the field.

## Features

- Stainless steel power element eliminates corrosion and prevents valve failure
- Wrench flats on inlet and outlet
- Forged brass valve body
- Inlet strainer assembly

## Specifications

Inlet connection size .....3/8" SAE, Outlet 1/2" SAE  
 Maximum working pressure ..... 652 psig (45 bar)  
 Maximum bulb temperature .....165°F (74°C)

### TI series cages

Cage size	Nominal capacity (kw)			Model number	Item number
	R-134A	R-22/R-407C	R-404A / R-507		
00	0.3	0.5	0.4	TIO-00X 800532	065087
0	0.8	1.3	1	TIO-000 800533	065088
1	1.9	3.2	2.3	TIO-001 800534	065090
2	3.1	5.3	3.9	TIO-002 800535	065091
3	5	8.5	6.2	TIO-003 800536	065092
4	8.3	13.9	10.1	TIO-004 800537	065093
5	10.1	16.9	12.3	TIO-005 800538	065094
6	11.7	19.5	14.2	TIO-006 800539	065095

NOTE: Nominal capacities in this section are based on European standards of +38°C condensing temperature, +4°C evaporating temperature and 1°K liquid subcooling at the inlet of the expansion valve. This methodology varies from the rest of the capacity tables in the TXV product offering.

### Model number nomenclature bodies

Series	Equalizer	System refrigerant code	Charge code	Unique identifier
TI	E	H	W	802421
Interchangeable Cage Capacities	E = External (Omit for Internal)	F = R-12 H = R-22 M = R-134a P = R-507 S = R-404A	C or W= Medium Temp. W (MOP) = Press. Limiting	

### TI series bodies - Flare type

Equalizer	System refrigerant code	Charge code	Inlet x outlet size	Model number	Item number
External	H (R-22/R-407C)	W ( Med. Temp.)	3/8" X 1/2" SAE	TIE-HW 802421	066390
External	M (R-134a)	W ( Med. Temp.)	3/8" X 1/2" SAE	TIE-MW 802446	066388
External	S (R-404A/R-507)	W ( Med. Temp.)	3/8" X 1/2" SAE	TIE-SW 802460	066392
Internal	H (R-22/R-407C)	W ( Med. Temp.)	3/8" X 1/2" SAE	TI-HW 802420	066389
Internal	M (R-134a)	W ( Med. Temp.)	3/8" X 1/2" SAE	TI-MW 802445	066387
Internal	S (R-404A/R-507)	W ( Med. Temp.)	3/8" X 1/2" SAE	TI-SW 802459	066391

NOTE: Evaporating temperature range -10°F to 40°F.



# ZZ Series Thermostatic Expansion Valves

The ZZ series is designed for ultra low temperature applications such as environmental test chambers and other applications where the desired evaporator temperature is below -40°F.

## Features

- Take-apart construction for easy field service
- Improved internal construction extends valve life
- External equalizer standard
- Exclusive cage bellows eliminates friction at low temperatures
- External superheat adjustment
- Interchangeable cages, power assemblies and flanges

## Specifications

Maximum working pressure .....450 psig (31 bar)

### ZZ series cage kits

Valve	Model number	Item number
ZZC1BG, ZC3/4RHW, ZC3/4RW	X-10110-B1B	021288
ZZC2-1/2BG, ZC1-1/2HW, ZC1-1/2RW	X-10110-B2B	020871
ZZC4BG, ZC2-1/2HW, ZC2-1/2RW	X-10110-B3B	096091
ZZC6BG, ZC4HW, ZC3-1/2RW	X-10110-B4B	096312
ZZC9BG, ZC6HW, ZC5RW	X-10110-B5B	096425
ZZC13BG, ZC8HW, ZC8RW	X-10110-B6B	096646
ZZER6BG, ZZER4HW, ZC3-1/2RW	X-10059-B4B	045362
ZZER20BG, ZZER12HW, ZZER11RW	X-10059-B6B	030071
ZZER21BG, ZZER13HW, ZZER13RW	X-10059-B7B	025100
ZZER29BG, ZZER18HW, ZZER18RW	X-10059-B8B	025101
ZZIR48BG, ZZIR30HW, ZZIR29RW	X-10060-B10B	025090
ZZJR16BG, ZZJR10HW, ZZJR9RW	X-10111-B5B	089306

### ZZ-series flanges

Configuration	Inlet connection	Outlet connection	Model number	Item number
Straight Thru	1/2" ODF	7/8" ODF	9761-2	027770
Straight Thru	3/8" ODF	5/8" ODF	9761-3	027771
Straight Thru	1/2" ODF	5/8" ODF	9761-4	027268
Straight Thru	3/8" ODF	1/2" ODF	9761-5	027769
Straight Thru	1/2" ODF	1/2" ODF	9761-9	027766
Angle	3/8" SAE	1/2" SAE	C-500-4	056932
Angle	1/2" SAE	5/8" SAE	C-500-6	056294
Angle	3/8" SAE	1/2" ODF	C-501-4	065527
Angle	3/8" SAE	5/8" ODF	C-501-5	065748
Angle	1/2" SAE	5/8" ODF	C-501-7	065861

*ZZ series power assembly model nomenclature - Example: XC-726BG30-2B*

Print reference	System refrigerant code	Charge code	Capillary tube length code	Equalizer
XC-726	B	G30	2	B
XC-726 = Drawing Number	B = R-13/R-23 H = R-22 R = R-502	G(MOP) = Press. Limiting W(MOP) = Press. Limiting Z = Low Temp.	1 = 5 Ft. 2 = 10 Ft. 3 = 15 Ft.	B = External

*ZZ series power assemblies*

Print reference	System refrigerant code	Charge code	Capillary tube	Equalizer	Model number	Item number
XC-726	B (R-13, R-23)	G30 (MOP)	10 Ft.	External	XC-726BG30-2B	094594
XC-726	B (R-13, R-23)	G125 (MOP)	10 Ft.	External	XC-726BG125-2B	039130
XC-726	H (R-22)	W35 (MOP)	10 Ft.	External	XC-726HW35-2B	024511
XC-726	H (R-22)	W65 (MOP)	10 Ft.	External	XC-726HW65-2B	025011
XC-726	H (R-22)	W85 (MOP)	15 Ft.	External	XC-726HW85-3B	023357
XC-726	H (R-22)	W100 (MOP)	10 Ft.	External	XC-726HW100-2B	036750
XC-726	H (R-22)	Z (Low Temp.)	10 Ft.	External	XC-726HZ-2B	040569

*Replacement gasket set*

Model number	Item number
X-13455-1	027579

Gasket Set includes necessary body flange gasket & seat gasket.



# LCL Series Desuperheating Valves

The LCL take-apart Series is a de-superheating (liquid injection) valve used in conjunction with hot gas bypass to prevent excessive suction line superheat. LCL valves can be used for interstage cooling in compound systems.

### Features

- Stainless steel power element prevents corrosion and valve failure
- Take-apart construction for easy field service
- Interchangeable cages, body flanges, and power assemblies for versatility
- External superheat adjustment

### Specifications

Maximum working pressure ..... 450 psig (31 bar)

**Model number nomenclature - Example: LCLE 1A-02**

Valve series	Equalizer	Valve size	Charge code	Sequential identifier	Customer special	Pack type
LCL	E	1	A	-02		
De-Superheating Liquid Injection	E = External 1/4" SAE  (Omit for Internal)	Valve Size  (Contact application engineer for sizing)	See Charge Codes Table for Selection of A, B, or C	-01 Thru -99	G = Customer Special  (Omit for Standard)	B1 = Bulk Pack  (Omit for Individual Pack)

### LCL Series Thermostatic Expansion Valves

Valve size	Charge code	Inlet x outlet connection	Equalizer	Cap length	Model number	Item number
1	A	Valve Less Flange	Internal	5 Ft.	LCL 1A-01	022018
1	B	Valve Less Flange	Internal	5 Ft.	LCL 1B-01	022017
2	A	Valve Less Flange	External	5 Ft.	LCLE 2A-01	022003
2	A	Valve Less Flange	Internal	5 Ft.	LCL 2A-01	022005
2	B	Valve Less Flange	External	5 Ft.	LCLE 2B-01	021997
2	B	Valve Less Flange	Internal	5 Ft.	LCL 2B-01	021996
3	A	Valve Less Flange	External	5 Ft.	LCLE 3A-01	021991
3	A	Valve Less Flange	Internal	5 Ft.	LCL 3A-02	055093
6	B	Valve Less Flange	Internal	5 Ft.	LCL 6B-01	021961

LCL series charge codes

Saturated suction	Refrigerant					
	R-22		R-134A		R-404A / R-507	
	Required suction gas		Required suction gas		Required suction gas	
Temperature	45°F	65°F	45°F	65°F	45°F	65°F
40°F	—	A	—	B	—	—
30°F	—	A	B	B	—	A
20°F	A	B	B	C	—	A
10°F	B	B	B	C	A	B
0°F	B	B	C	C	A	B
-10°F	B	C	C	C	B	B
-20°F	B	C	C	C	B	C
-30°F	C	C	C	C	B	C
-40°F	C	C	C	C	B	C

LCL series cage kits

Valve	Capacity range reference (tons)	R-12	R-22	R-134A	R-404A / R-507	R-502	R-407C	Equalizer	Model number	Item number
TCL, LCL	1/4 to 1/2	1/4	1/2	1/4	1/4	1/4	1/2	Internal	X-22440-B1A	037034
TCL, LCL	1/4 to 1/2	1/4	1/2	1/4	1/4	1/4	1/2	External	X-22440-B1B	037035
TCL, LCL	1/2 to 1	1/2	1	3/4	1/2	1/2	1	Internal	X-22440-B2A	037036
TCL, LCL	1/2 to 1	1/2	1	3/4	1/2	1/2	1	External	X-22440-B2B	037037
TCL, LCL	1 to 2	1	2	1-1/2	1	1	2	Internal	X-22440-B3A	037038
TCL, LCL	1 to 2	1	2	1-1/2	1	1	2	External	X-22440-B3B	037039
TCL, LCL	2 to 3	2	3	2-1/2	2	2	3	Internal	X-22440-B4A	037040
TCL, LCL	2 to 3	2	3	2-1/2	2	2	3	External	X-22440-B4B	037041
TCL, LCL	3 to 5	3	4	3-1/2	3	3	5	External	X-22440-B5B	037043
TCL, LCL	4 to 7-1/2	4	7-1/2	5-1/2	4-1/2	4-1/2	7-1/2	External	X-22440-B6B	037045
TCL, LCL	6-1/2 to 10	6-1/2	10	7-1/2	7	7	10	External	X-22440-B7B	037047
TCL, LCL	7-1/2 to 12	7-1/2	12	9	8	8	12	External	X-22440-B8B	037049

LCL series flanges

Valve series	Configuration	Inlet connection	Outlet connection	Model number	Item number
LCL, LCLE	Angle	3/8" SAE	1/2" SAE	C-500-4	056932
LCL, LCLE	Angle	1/2" SAE	5/8" SAE	C-500-6	056294
LCL, LCLE	Angle	3/8" ODF	1/2" ODF	C-501-4	065527
LCL, LCLE	Angle	3/8" ODF	5/8" ODF	C-501-5	065748
LCL, LCLE	Angle	1/2" ODF	5/8" ODF	C-501-7	065861
LCL, LCLE	Angle	5/8" ODF or 7/8" ODM	7/8" ODF or 1-1/8" ODM	A-576	027764
LCL, LCLE	Straight Thru	3/8" SAE	1/2" SAE	X-6669-4	051176
LCL, LCLE	Straight Thru	3/8" SAE	5/8" SAE	X-6669-1	050563
LCL, LCLE	Straight Thru	1/2" SAE	1/2" SAE	X-6669-5	083378
LCL, LCLE	Straight Thru	1/2" SAE	5/8" SAE	X-6669-2	050842
LCL, LCLE	Straight Thru	3/8" ODF	1/2" ODF	9761-5	027769
LCL, LCLE	Straight Thru	3/8" ODF	5/8" ODF	9761-3	027771
LCL, LCLE	Straight Thru	1/2" ODF	1/2" ODF	9761-9	027766
LCL, LCLE	Straight Thru	1/2" ODF	5/8" ODF	9761-4	027268
LCL, LCLE	Straight Thru	1/2" ODF	7/8" ODF	9761-2	027770
LCL, LCLE	Straight Thru	5/8" ODF	5/8" ODF	X-6346-16	044733
LCL, LCLE	Straight Thru	5/8" ODF	7/8" ODF	X-6346-17	044846
LCL, LCLE	Straight Thru	5/8" ODF	1-1/8" ODF	X-6346-18	094038
LCL, LCLE	Straight Thru	7/8" ODF	1-1/8" ODF	X-6346-34	071757

*LCL series power assembly model nomenclature - Example: XB-1019A-1A*

Print reference	Charge code	Capillary tube length	Equalizer
XB-1019	A	1	A
XB-1019 = Drawing Number	A B C  See LCL Series Charge Code Table for Suction Gas Temperature by Gas Type	1 = 5 Ft.	A = Internal B = External

*LCL series power assemblies*

Print reference	Charge code	Capillary tube	Equalizer	Model number	Item number
XB-1019	A	5 Ft.	Internal	XB-1019A-1A	037389
XB-1019	B	5 Ft.	External	XB-1019B-1B	032207

*Replacement gasket set*

Model number	Item number
X-13455-1	027579

Gasket Set includes necessary body flange gasket & seat gasket.

# Conventional ported valve capacity tables

R-12 conventional ported valves (tons) - A Series / T Series

Valve type	Nom. rating	Evaporator temperature																	
		50°F						40°F						20°F					
		Pressure drop across valve (psi)						Pressure drop across valve (psi)						Pressure drop across valve (psi)					
		60	80	100	125	150	175	60	80	100	125	150	175	60	80	100	125	150	175
AA/ANI/AAC/ANC/AFA	1/8	0.20	0.23	0.26	0.29	0.32	0.34	0.20	0.23	0.26	0.29	0.32	0.34	0.19	0.22	0.25	0.27	0.30	0.32
AA/ANI/AAC/ANC/AFA	1/4	0.35	0.40	0.45	0.51	0.55	0.60	0.34	0.39	0.44	0.49	0.54	0.58	0.33	0.38	0.43	0.48	0.52	0.56
AA/ANI/AAC/ANC/AFA	1/2	0.56	0.65	0.72	0.81	0.89	0.96	0.55	0.64	0.71	0.79	0.87	0.94	0.53	0.61	0.68	0.76	0.84	0.91
AA/ANI/AAC/ANC/AFA	1	0.80	0.92	1.03	1.15	1.26	1.37	0.79	0.91	1.02	1.14	1.25	1.35	0.76	0.88	0.98	1.10	1.20	1.30
AA/ANI/AAC/ANC/AFA	1-1/2	1.66	1.92	2.14	2.40	2.62	2.83	1.63	1.88	2.10	2.35	2.58	2.78	1.58	1.80	2.01	2.25	2.47	2.66
AA/ANI/AAC/ANC/AFA	2	2.04	2.36	2.63	2.94	3.23	3.48	2.00	2.31	2.58	2.89	3.16	3.42	1.92	2.22	2.48	2.77	3.04	3.28
AA/ANI/AAC/ANC/AFA	2-1/2	2.42	2.79	3.12	3.49	3.83	4.13	2.37	2.74	3.06	3.42	3.75	4.05	2.28	2.63	2.94	3.29	3.60	3.89
AA/ANI/AAC/ANC/AFA	3	3.31	3.82	4.27	4.78	5.23	5.65	3.24	3.74	4.18	4.68	5.12	5.53	3.11	3.59	4.01	4.49	4.92	5.31
TCLE	1/4	0.30	0.35	0.38	0.43	0.47	0.51	0.30	0.35	0.39	0.43	0.47	0.51	0.28	0.32	0.36	0.40	0.44	0.48
TCLE	1/2	0.57	0.66	0.74	0.82	0.90	0.97	0.56	0.65	0.72	0.81	0.89	0.96	0.53	0.61	0.68	0.76	0.84	0.91
TCLE	1	1.15	1.33	1.48	1.66	1.82	1.96	1.13	1.30	1.48	1.63	1.79	1.93	1.08	1.25	1.39	1.56	1.71	1.84
TCLE	2	2.12	2.45	2.74	3.06	3.35	3.62	2.08	2.40	2.69	3.00	3.29	3.55	1.99	2.30	2.57	2.84	3.15	3.40
TCLE	3	3.09	3.57	3.99	4.46	4.89	5.28	3.03	3.50	3.91	4.37	4.79	5.17	2.90	3.35	3.74	4.19	4.59	4.95
TCLE	4	4.48	5.17	5.78	6.47	7.08	7.65	4.39	5.07	5.67	6.34	6.94	7.50	4.21	4.86	5.44	6.08	6.66	7.19
TCLE	6-1/2	6.17	7.12	7.97	8.91	9.76	10.54	6.05	6.99	7.81	8.73	9.57	10.33	5.80	6.70	7.49	8.37	9.17	9.91
TCLE	7-1/2	7.44	8.59	9.60	10.74	11.76	12.71	7.30	8.43	9.42	10.54	11.54	12.47	7.00	8.08	9.04	10.10	11.07	11.95
TJL	7	6.59	7.51	8.51	9.51	10.42	11.25	6.47	7.47	8.35	9.34	10.23	11.05	6.20	7.16	8.00	8.95	9.80	10.59
TJL	8	8.41	9.71	10.86	12.14	13.30	14.36	8.25	9.53	10.65	11.91	13.04	14.09	7.91	9.13	10.21	11.42	12.51	13.51

NOTE: Standard capacity is rated at 100F liquid inlet and 40F evaporator temperature; with 60 PSI pressure drop across the TXV per ARI 750-2001.

Valve type	Nom. rating	Evaporator temperature																	
		0°F						-20°F						-40°F					
		Pressure drop across valve (psi)						Pressure drop across valve (psi)						Pressure drop across valve (psi)					
		60	80	100	125	150	175	80	100	125	150	175	200	80	100	125	150	175	200
AA/ANI/AAC/ANC/AFA	1/8	0.17	0.2	0.22	0.25	0.27	0.29	0.13	0.15	0.16	0.18	0.19	0.21	0.08	0.09	0.1	0.11	0.12	0.13
AA/ANI/AAC/ANC/AFA	1/4	0.29	0.33	0.37	0.42	0.46	0.5	0.23	0.26	0.29	0.31	0.34	0.36	0.15	0.17	0.19	0.21	0.22	0.24
AA/ANI/AAC/ANC/AFA	1/2	0.47	0.54	0.61	0.68	0.74	0.8	0.37	0.41	0.46	0.51	0.55	0.59	0.24	0.27	0.3	0.33	0.35	0.38
AA/ANI/AAC/ANC/AFA	1	0.67	0.77	0.86	0.97	1.06	1.14	0.53	0.59	0.66	0.73	0.78	0.84	0.34	0.38	0.43	0.47	0.5	0.54
AA/ANI/AAC/ANC/AFA	1-1/2	1.39	1.61	1.79	2.01	2.2	2.37	1.09	1.22	1.36	1.49	1.61	1.72	0.71	0.79	0.89	0.97	1.05	1.12
AA/ANI/AAC/ANC/AFA	2	1.7	1.96	2.19	2.45	2.69	2.9	1.33	1.49	1.66	1.82	1.97	2.1	0.87	0.97	1.09	1.19	1.29	1.38
AA/ANI/AAC/ANC/AFA	2-1/2	2.02	2.33	2.61	2.92	3.19	3.45	1.58	1.77	1.98	2.16	2.34	2.50	1.03	1.15	1.29	1.41	1.52	1.63
AA/ANI/AAC/ANC/AFA	3	2.76	3.19	3.56	3.98	4.36	4.71	2.16	2.41	2.7	2.96	3.19	3.42	1.4	1.57	1.75	1.92	2.07	2.21
TCLE	1/4	0.25	0.29	0.32	0.36	0.4	0.43	0.2	0.22	0.25	0.27	0.3	0.32	0.13	0.15	0.16	0.18	0.19	0.21
TCLE	1/2	0.47	0.54	0.61	0.68	0.74	0.8	0.37	0.41	0.46	0.51	0.55	0.59	0.24	0.27	0.3	0.33	0.35	0.38
TCLE	1	0.96	1.11	1.24	1.39	1.52	1.64	0.75	0.84	0.94	1.03	1.11	1.19	0.49	0.55	0.61	0.67	0.72	0.77
TCLE	2	1.76	2.03	2.27	2.54	2.78	3.01	1.38	1.54	1.73	1.89	2.04	2.18	0.9	1.01	1.13	1.23	1.33	1.42
TCLE	3	2.57	2.97	3.32	3.71	4.06	4.39	2.01	2.25	2.51	2.75	2.97	3.18	1.31	1.46	1.64	1.79	1.94	2.07
TCLE	4	3.73	4.31	4.82	5.38	5.9	6.37	2.92	3.26	3.65	4	4.32	4.62	1.9	2.12	2.38	2.6	2.81	3
TCLE	6-1/2	5.14	5.94	6.64	7.42	8.13	8.78	4.03	4.51	5.04	5.52	5.96	6.37	2.62	2.93	3.28	3.59	3.88	4.14
TCLE	7-1/2	6.2	7.16	8	8.95	9.8	10.59	4.86	5.43	6.08	6.65	7.19	7.68	3.16	3.53	3.95	4.33	4.67	5
TJL	7	5.49	6.34	7.09	7.92	8.68	9.38	4.3	4.81	5.38	5.89	6.36	6.8	2.8	3.13	3.5	3.83	4.14	4.43
TJL	8	7	8.08	9.04	10.1	11.07	11.95	5.49	6.14	6.86	7.52	8.12	8.68	3.57	3.99	4.46	4.89	5.28	5.64

### Refrigerant liquid temperature correction factors

	Refrigerant liquid temperature °F															
	0	10	20	30	40	50	60	70	80	90	100	110	120	130	140	
R-12	1.60	1.54	1.48	1.42	1.36	1.30	1.24	1.18	1.12	1.06	1.00	0.94	0.88	0.82	0.75	

NOTE: These factors include corrections for liquid refrigerant density and net refrigeration effect, and are based on an average evaporator temperature of 0°F with a maximum 7°F Change in Superheat. However, they may be used for any evaporator temperature from -40°F to +40°F since the variation in the actual factors across this range is insignificant.

R-22 conventional ported valves (tons) A Series / AFA Series / T Series

Valve type	Nom. rating	Evaporator temperature																	
		50°F						40°F						20°F					
		Pressure drop across valve (psi)						Pressure drop across valve (psi)						Pressure drop across valve (psi)					
		60	80	100	125	150	175	60	80	100	125	150	175	60	80	100	125	150	175
AA/AN/AFA	1/5	0.15	0.17	0.19	0.22	0.24	0.26	0.15	0.17	0.19	0.21	0.23	0.25	0.14	0.16	0.18	0.20	0.22	0.24
AA/AN/AAC/ANC	1/4	0.26	0.30	0.34	0.38	0.41	0.44	0.26	0.30	0.33	0.37	0.40	0.44	0.25	0.29	0.32	0.36	0.40	0.43
AA/AN/AAC/ANC/AFA	1/2	0.46	0.53	0.59	0.66	0.73	0.79	0.45	0.52	0.58	0.65	0.71	0.77	0.44	0.51	0.57	0.64	0.70	0.75
AA/AN/AAC/ANC/AFA	1	0.73	0.84	0.94	1.05	1.15	1.25	0.72	0.83	0.93	1.04	1.14	1.23	0.70	0.81	0.90	1.01	1.11	1.20
AA/AN/AAC/ANC/AFA	1-1/2	1.05	1.21	1.36	1.52	1.66	1.79	1.03	1.19	1.33	1.49	1.63	1.76	1.01	1.17	1.30	1.46	1.60	1.72
AA/AN/AAC/ANC/AFA	2	1.54	1.78	1.99	2.22	2.43	2.63	1.52	1.75	1.96	2.19	2.40	2.59	1.48	1.71	1.91	2.14	2.34	2.53
AA/AN/AAC/ANC/AFA	2-1/2	2.16	2.49	2.79	3.12	3.42	3.69	2.13	2.46	2.75	3.07	3.37	3.64	2.08	2.40	2.69	3.00	3.29	3.55
AA/AN/AAC/ANC/AFA	3	2.65	3.06	3.42	3.82	4.19	4.53	2.61	3.01	3.37	3.77	4.13	4.46	2.55	2.94	3.29	3.68	4.03	4.35
AA/AN/AAC/ANC/AFA	4	3.14	3.63	4.05	4.53	4.96	5.36	3.10	3.58	4.00	4.47	4.90	5.29	3.03	3.50	3.91	4.37	4.79	5.17
AA/AN/AAC/ANC/AFA	5	4.30	4.97	5.55	6.21	6.80	7.34	4.24	4.89	5.47	6.12	6.70	7.24	4.14	4.78	5.34	5.98	6.55	7.07
TCLE	1/2	0.39	0.45	0.50	0.56	0.62	0.67	0.39	0.45	0.50	0.56	0.61	0.66	0.38	0.44	0.49	0.55	0.60	0.65
TCLE	1	0.74	0.85	0.96	1.07	1.17	1.26	0.73	0.84	0.94	1.05	1.15	1.24	0.71	0.82	0.92	1.02	1.12	1.21
TCLE	2	1.49	1.72	1.92	2.15	2.36	2.54	1.47	1.70	1.90	2.12	2.33	2.51	1.44	1.66	1.86	2.08	2.28	2.46
TCLE	3	2.75	3.18	3.55	3.97	4.35	4.70	2.71	3.13	3.50	3.91	4.29	4.63	2.65	3.06	3.42	3.82	4.19	4.53
TCLE	5	4.01	4.63	5.18	5.79	6.34	6.85	3.95	4.56	5.10	5.70	6.25	6.75	3.86	4.46	4.98	5.57	6.10	6.59
TCLE	7-1/2	5.82	6.72	7.51	8.40	9.20	9.94	5.75	6.64	7.42	8.30	9.09	9.82	5.60	6.47	7.23	8.08	8.85	9.56
TCLE	10	8.02	9.26	10.35	11.58	12.68	13.70	7.92	9.15	10.23	11.44	12.53	13.53	7.72	8.91	9.97	11.14	12.21	13.18
TCLE	12	9.67	11.17	12.48	13.96	15.29	16.51	9.55	11.03	12.33	13.79	15.10	16.31	9.31	10.75	12.02	13.44	14.72	15.90
TJL	11	8.57	9.90	11.06	12.37	13.55	14.64	8.47	9.78	10.93	12.22	13.39	14.46	8.25	9.53	10.65	11.91	13.04	14.09
TJL	14	10.92	12.61	14.10	15.76	17.27	18.65	10.80	12.47	13.94	15.59	17.07	18.44	10.52	12.15	13.58	15.18	16.63	17.97

NOTE: Standard capacity is rated at 100°F liquid inlet and 40°F evaporator temperature; with 100 PSI pressure drop across the TXV per ARI 750-2001.

Valve type	Nom. rating	Evaporator temperature																	
		0°F						-20°F						-40°F					
		Pressure drop across valve (psi)						Pressure drop across valve (psi)						Pressure drop across valve (psi)					
		60	80	100	125	150	175	80	100	125	150	175	200	80	100	125	150	175	200
AA/AN/AFA	1/5	0.13	0.15	0.17	0.19	0.21	0.22	0.10	0.11	0.13	0.14	0.15	0.16	0.07	0.08	0.09	0.10	0.10	0.11
AA/AN/AAC/ANC	1/4	0.23	0.27	0.30	0.33	0.36	0.39	0.18	0.20	0.23	0.25	0.27	0.28	0.12	0.13	0.15	0.16	0.18	0.19
AA/AN/AAC/ANC/AFA	1/2	0.40	0.46	0.52	0.58	0.63	0.68	0.32	0.36	0.40	0.44	0.47	0.51	0.21	0.23	0.26	0.29	0.31	0.33
AA/AN/AAC/ANC/AFA	1	0.64	0.74	0.83	0.92	1.01	1.09	0.51	0.57	0.64	0.70	0.75	0.81	0.34	0.38	0.43	0.47	0.50	0.54
AA/AN/AAC/ANC/AFA	1-1/2	0.91	1.05	1.17	1.31	1.44	1.55	0.73	0.82	0.91	1.00	1.08	1.15	0.48	0.54	0.60	0.66	0.71	0.76
AA/AN/AAC/ANC/AFA	2	1.35	1.56	1.74	1.95	2.13	2.31	1.07	1.20	1.34	1.47	1.58	1.69	0.71	0.79	0.89	0.97	1.05	1.12
AA/AN/AAC/ANC/AFA	2-1/2	1.89	2.18	2.44	2.73	2.99	3.23	1.51	1.69	1.89	2.07	2.23	2.39	0.99	1.11	1.24	1.36	1.46	1.57
AA/AN/AAC/ANC/AFA	3	2.31	2.67	2.98	3.33	3.65	3.95	1.85	2.07	2.31	2.53	2.74	2.93	1.22	1.36	1.53	1.67	1.80	1.93
AA/AN/AAC/ANC/AFA	4	2.75	3.18	3.55	3.97	4.35	4.70	2.19	2.45	2.74	3.00	3.24	3.46	1.44	1.61	1.80	1.97	2.13	2.28
AA/AN/AAC/ANC/AFA	5	3.75	4.33	4.84	5.41	5.93	6.40	3.00	3.35	3.75	4.11	4.44	4.74	1.97	2.20	2.46	2.70	2.91	3.11
TCLE	1/2	0.34	0.39	0.44	0.49	0.54	0.58	0.27	0.30	0.34	0.37	0.40	0.43	0.18	0.20	0.23	0.25	0.27	0.28
TCLE	1	0.65	0.75	0.84	0.94	1.03	1.11	0.52	0.58	0.65	0.71	0.77	0.82	0.34	0.38	0.43	0.47	0.50	0.54
TCLE	2	1.30	1.50	1.68	1.88	2.06	2.22	1.04	1.16	1.30	1.42	1.54	1.64	0.69	0.77	0.86	0.94	1.02	1.09
TCLE	3	2.40	2.77	3.10	3.46	3.79	4.10	1.92	2.15	2.40	2.63	2.84	3.04	1.26	1.41	1.58	1.73	1.86	1.99
TCLE	5	3.50	4.04	4.52	5.05	5.53	5.98	2.79	3.12	3.49	3.82	4.13	4.41	1.84	2.06	2.30	2.52	2.72	2.91
TCLE	7-1/2	5.08	5.87	6.56	7.33	8.03	8.68	4.05	4.53	5.06	5.55	5.99	6.40	2.67	2.99	3.34	3.66	3.95	4.22
TCLE	10	7.00	8.08	9.04	10.10	11.07	11.95	5.59	6.25	6.99	7.65	8.27	8.84	3.68	4.11	4.60	5.04	5.44	5.82
TCLE	12	8.44	9.75	10.90	12.18	13.34	14.41	6.74	7.54	8.43	9.23	9.97	10.66	4.44	4.96	5.55	6.08	6.57	7.02
TJL	11	7.48	8.64	9.66	10.80	11.83	12.77	5.97	6.67	7.46	8.17	8.83	9.44	3.93	4.39	4.91	5.38	5.81	6.21
TJL	14	9.54	11.02	12.32	13.77	15.08	16.29	7.62	8.52	9.53	10.43	11.27	12.05	5.02	5.61	6.28	6.87	7.42	7.94

Refrigerant liquid temperature correction factors

	Refrigerant liquid temperature °f															
	0	10	20	30	40	50	60	70	80	90	100	110	120	130	140	
R-22	1.56	1.51	1.45	1.40	1.34	1.29	1.23	1.17	1.12	1.06	1.00	0.94	0.88	0.82	0.76	

NOTE: These factors include corrections for liquid refrigerant density and net refrigerating effect and are based on an average evaporator temperature of 0°F. However, they may be used for any evaporator temperature from -40°F to +40°F since the variation in the actual factors across this range is insignificant.

R-134a conventional ported valves (tons) A Series / AFA Series / T Series

Valve type	Nom. rating	Evaporator temperature																	
		50°F						40°F						20°F					
		Pressure drop across valve (psi)						Pressure drop across valve (psi)						Pressure drop across valve (psi)					
		60	80	100	125	150	175	60	80	100	125	150	175	60	80	100	125	150	175
AA/AN/AFA	1/8	0.14	0.16	0.18	0.20	0.22	0.24	0.14	0.16	0.18	0.20	0.22	0.24	0.13	0.15	0.17	0.19	0.21	0.22
AA/AN/AAC/ANC/AFA	1/4	0.25	0.29	0.32	0.36	0.40	0.43	0.24	0.28	0.31	0.35	0.38	0.41	0.23	0.27	0.30	0.33	0.36	0.39
AA/AN/AAC/ANC/AFA	1/2	0.43	0.50	0.56	0.62	0.68	0.73	0.43	0.50	0.56	0.62	0.68	0.73	0.41	0.47	0.53	0.59	0.65	0.70
AA/AN/AAC/ANC/AFA	3/4	0.70	0.81	0.90	1.01	1.11	1.20	0.68	0.79	0.88	0.98	1.08	1.16	0.65	0.75	0.84	0.94	1.03	1.11
AA/AN/AAC/ANC/AFA	1	1.00	1.15	1.29	1.44	1.58	1.71	0.98	1.13	1.27	1.41	1.55	1.67	0.93	1.07	1.20	1.34	1.47	1.59
AA/AN/AAC/ANC/AFA	1-1/2	1.47	1.70	1.90	2.12	2.32	2.51	1.44	1.66	1.86	2.08	2.28	2.46	1.38	1.59	1.78	1.99	2.18	2.36
AA/AN/AAC/ANC/AFA	2	2.06	2.38	2.66	2.97	3.26	3.52	2.02	2.33	2.61	2.92	3.19	3.45	1.93	2.23	2.49	2.79	3.05	3.30
AA/AN/AAC/ANC/AFA	2-1/2	2.53	2.92	3.27	3.65	4.00	4.32	2.47	2.85	3.19	3.57	3.91	4.22	2.37	2.74	3.06	3.42	3.75	4.05
AA/AN/AAC/ANC/AFA	3	3.00	3.46	3.87	4.33	4.74	5.12	2.94	3.39	3.80	4.24	4.65	5.02	2.81	3.24	3.63	4.06	4.44	4.80
AA/AN/AAC/ANC/AFA	4	4.10	4.73	5.29	5.92	6.48	7.00	4.02	4.64	5.19	5.80	6.36	6.87	3.84	4.43	4.96	5.54	6.07	6.56
TCLE	1/4	0.37	0.43	0.48	0.53	0.59	0.63	0.37	0.43	0.48	0.53	0.59	0.63	0.35	0.40	0.45	0.51	0.55	0.60
TCLE	3/4	0.70	0.81	0.90	1.01	1.11	1.20	0.69	0.80	0.89	1.00	1.09	1.18	0.66	0.76	0.85	0.95	1.04	1.13
TCLE	1-1/2	1.42	1.64	1.83	2.05	2.25	2.43	1.39	1.61	1.79	2.01	2.20	2.37	1.33	1.54	1.72	1.92	2.10	2.27
TCLE	2-1/2	2.62	3.03	3.38	3.78	4.14	4.47	2.57	2.97	3.32	3.71	4.06	4.39	2.46	2.84	3.18	3.55	3.89	4.20
TCLE	3-1/2	3.82	4.41	4.93	5.51	6.04	6.52	3.74	4.32	4.83	5.40	5.91	6.39	3.58	4.13	4.62	5.17	5.66	6.11
TCLE	5-1/2	5.55	6.41	7.17	8.01	8.78	9.48	5.43	6.27	7.01	7.84	8.59	9.27	5.20	6.00	6.71	7.51	8.22	8.88
TCLE	7-1/2	7.65	8.83	9.88	11.04	12.10	13.06	7.49	8.65	9.67	10.81	11.84	12.79	7.16	8.27	9.24	10.33	11.32	12.23
TCLE	9	9.22	10.65	11.90	13.31	14.58	15.75	9.03	10.43	11.66	13.03	14.28	15.42	8.64	9.98	11.15	12.47	13.66	14.76
TJL	9	8.17	9.43	10.55	11.79	12.92	13.95	8.00	9.24	10.33	11.55	12.65	13.66	7.65	8.83	9.88	11.04	12.10	13.06
TJL	11	10.42	12.03	13.45	15.04	16.48	17.80	10.20	11.78	13.17	14.72	16.13	17.42	9.76	11.27	12.60	14.09	15.43	16.67

NOTE: Standard capacity is rated at 100°F liquid inlet and 40°F evaporator temperature; with 60 PSI pressure drop across the TXV per ARI 750-2001.

Valve type	Nom. rating	Evaporator temperature																	
		0°F						-20°F						-40°F					
		Pressure drop across valve (psi)						Pressure drop across valve (psi)						Pressure drop across valve (psi)					
		60	80	100	125	150	175	80	100	125	150	175	200	80	100	125	150	175	200
AA/AN/AFA	1/8	0.11	0.13	0.14	0.16	0.17	0.19	0.08	0.09	0.10	0.11	0.12	0.13	0.05	0.06	0.06	0.07	0.07	0.08
AA/AN/AAC/ANC/AFA	1/4	0.19	0.22	0.25	0.27	0.30	0.32	0.14	0.16	0.18	0.19	0.21	0.22	0.09	0.10	0.11	0.12	0.13	0.14
AA/AN/AAC/ANC/AFA	1/2	0.34	0.39	0.44	0.49	0.54	0.58	0.25	0.28	0.31	0.34	0.37	0.40	0.15	0.17	0.19	0.21	0.22	0.24
AA/AN/AAC/ANC/AFA	3/4	0.54	0.62	0.70	0.78	0.85	0.92	0.40	0.45	0.50	0.55	0.59	0.63	0.25	0.28	0.31	0.34	0.37	0.40
AA/AN/AAC/ANC/AFA	1	0.77	0.89	0.99	1.11	1.22	1.32	0.57	0.64	0.71	0.78	0.84	0.90	0.35	0.39	0.44	0.48	0.52	0.55
AA/AN/AAC/ANC/AFA	1-1/2	1.13	1.30	1.46	1.63	1.79	1.93	0.85	0.95	1.06	1.16	1.26	1.34	0.52	0.58	0.65	0.71	0.77	0.82
AA/AN/AAC/ANC/AFA	2	1.59	1.84	2.05	2.29	2.51	2.72	1.19	1.33	1.49	1.63	1.76	1.88	0.73	0.82	0.91	1.00	1.08	1.15
AA/AN/AAC/ANC/AFA	2-1/2	1.95	2.25	2.52	2.81	3.08	3.33	1.45	1.62	1.81	1.99	2.14	2.29	0.89	1.00	1.11	1.22	1.32	1.41
AA/AN/AAC/ANC/AFA	3	2.31	2.67	2.98	3.33	3.65	3.95	1.72	1.92	2.15	2.36	2.54	2.72	1.06	1.19	1.33	1.45	1.57	1.68
AA/AN/AAC/ANC/AFA	4	3.16	3.65	4.08	4.56	5.00	5.40	2.36	2.64	2.95	3.23	3.49	3.73	1.45	1.62	1.81	1.99	2.14	2.29
TCLE	1/4	0.29	0.33	0.37	0.42	0.46	0.50	0.22	0.25	0.28	0.30	0.33	0.35	0.13	0.15	0.16	0.18	0.19	0.21
TCLE	3/4	0.54	0.62	0.70	0.78	0.85	0.92	0.41	0.46	0.51	0.56	0.61	0.65	0.25	0.28	0.31	0.34	0.37	0.40
TCLE	1-1/2	1.10	1.27	1.42	1.59	1.74	1.88	0.82	0.92	1.03	1.12	1.21	1.30	0.50	0.56	0.63	0.68	0.74	0.79
TCLE	2-1/2	2.02	2.33	2.61	2.92	3.19	3.45	1.51	1.69	1.89	2.07	2.23	2.39	0.93	1.04	1.16	1.27	1.38	1.47
TCLE	3-1/2	2.95	3.41	3.81	4.26	4.66	5.04	2.20	2.46	2.75	3.01	3.25	3.48	1.35	1.51	1.69	1.85	2.00	2.13
TCLE	5-1/2	4.28	4.94	5.53	6.18	6.77	7.31	3.19	3.57	3.99	4.37	4.72	5.04	1.96	2.19	2.45	2.68	2.90	3.10
TCLE	7-1/2	5.90	6.81	7.62	8.52	9.33	10.08	4.40	4.92	5.50	6.02	6.51	6.96	2.70	3.02	3.38	3.70	3.99	4.27
TCLE	9	7.11	8.21	9.18	10.26	11.24	12.14	5.30	5.93	6.63	7.26	7.84	8.38	3.26	3.64	4.08	4.46	4.82	5.15
TJL	9	6.30	7.27	8.13	9.09	9.96	10.76	4.70	5.25	5.88	6.44	6.95	7.43	2.89	3.23	3.61	3.96	4.27	4.57
TJL	11	8.03	9.27	10.37	11.59	12.70	13.71	5.99	6.70	7.49	8.20	8.86	9.47	3.68	4.11	4.60	5.04	5.44	5.82

Refrigerant liquid temperature correction factors

	Refrigerant liquid temperature °f															
	0	10	20	30	40	50	60	70	80	90	100	110	120	130	140	
R-134a	1.70	1.63	1.56	1.49	1.42	1.36	1.29	1.21	1.14	1.07	1.00	0.93	0.85	0.78	0.71	

NOTE: These factors include corrections for liquid refrigerant density and net refrigerating effect and are based on an average evaporator temperature of 0°F. However, they may be used for any evaporator temperature from -40°F to +40°F since the variation in the actual factors across this range is insignificant.

R-290 conventional ported valves (tons) A Series

Valve type	Nom. rating	Evaporator temperature																	
		50°F						40°F						20°F					
		Pressure drop across valve (psi)						Pressure drop across valve (psi)						Pressure drop across valve (psi)					
		60	80	100	125	150	175	60	80	100	125	150	175	60	80	100	125	150	175
AA/AN/AFA	1/5	0.14	0.16	0.18	0.20	0.22	0.24	0.14	0.16	0.18	0.20	0.21	0.23	0.13	0.15	0.17	0.19	0.21	0.22
AA/AN/AAC/ANC	1/4	0.24	0.28	0.31	0.35	0.38	0.41	0.24	0.27	0.30	0.34	0.37	0.40	0.23	0.26	0.29	0.33	0.36	0.38
AA/AN/AAC/ANC/AFA	1/2	0.42	0.49	0.55	0.61	0.67	0.72	0.41	0.48	0.53	0.60	0.66	0.71	0.40	0.46	0.51	0.57	0.63	0.68
AA/AN/AAC/ANC/AFA	1	0.68	0.78	0.88	0.98	1.07	1.16	0.66	0.77	0.86	0.96	1.05	1.13	0.64	0.73	0.82	0.92	1.00	1.08
AA/AN/AAC/ANC/AFA	1-1/2	0.97	1.12	1.25	1.40	1.53	1.66	0.95	1.10	1.23	1.37	1.50	1.62	0.91	1.05	1.17	1.31	1.44	1.55
AA/AN/AAC/ANC/AFA	2	1.43	1.65	1.85	2.06	2.26	2.44	1.40	1.62	1.81	2.02	2.21	2.39	1.34	1.55	1.73	1.93	2.12	2.29
AA/AN/AAC/ANC/AFA	2-1/2	2.01	2.32	2.59	2.90	3.17	3.43	1.96	2.27	2.54	2.84	3.11	3.36	1.88	2.17	2.42	2.71	2.97	3.21
AA/AN/AAC/ANC/AFA	3	2.46	2.84	3.17	3.55	3.89	4.20	2.41	2.78	3.11	3.48	3.81	4.11	2.30	2.66	2.97	3.32	3.64	3.93
AA/AN/AAC/ANC/AFA	4	2.92	3.37	3.77	4.21	4.61	4.98	2.86	3.30	3.69	4.12	4.52	4.88	2.73	3.15	3.53	3.94	4.32	4.67
AA/AN/AAC/ANC/AFA	5	3.99	4.61	5.15	5.76	6.31	6.82	3.91	4.51	5.04	5.64	6.18	6.67	3.74	4.31	4.82	5.39	5.91	6.38

NOTE: Standard capacity is rated at 100°F liquid inlet and 40°F evaporator temperature; with 100 PSI pressure drop across the TXV per ARI 750-2001.

Valve type	Nom. rating	Evaporator temperature																	
		0°F						-20°F						-40°F					
		Pressure drop across valve (psi)						Pressure drop across valve (psi)						Pressure drop across valve (psi)					
		60	80	100	125	150	175	80	100	125	150	175	200	80	100	125	150	175	200
AA/AN/AFA	1/5	0.11	0.12	0.14	0.15	0.17	0.18	0.08	0.10	0.11	0.12	0.13	0.13	0.06	0.06	0.07	0.08	0.08	0.09
AA/AN/AAC/ANC	1/4	0.18	0.21	0.24	0.26	0.29	0.31	0.15	0.17	0.18	0.20	0.22	0.23	0.10	0.11	0.12	0.14	0.15	0.16
AA/AN/AAC/ANC/AFA	1/2	0.32	0.37	0.42	0.47	0.51	0.55	0.26	0.29	0.32	0.36	0.38	0.41	0.17	0.19	0.22	0.24	0.26	0.27
AA/AN/AAC/ANC/AFA	1	0.52	0.60	0.67	0.75	0.82	0.88	0.42	0.47	0.52	0.57	0.62	0.66	0.28	0.31	0.35	0.38	0.41	0.44
AA/AN/AAC/ANC/AFA	1-1/2	0.74	0.85	0.95	1.07	1.17	1.26	0.59	0.67	0.74	0.81	0.88	0.94	0.40	0.45	0.50	0.55	0.59	0.63
AA/AN/AAC/ANC/AFA	2	1.09	1.26	1.41	1.57	1.72	1.86	0.88	0.98	1.10	1.20	1.30	1.39	0.59	0.66	0.73	0.80	0.87	0.93
AA/AN/AAC/ANC/AFA	2-1/2	1.53	1.76	1.97	2.20	2.42	2.61	1.23	1.38	1.54	1.68	1.82	1.95	0.82	0.92	1.03	1.13	1.22	1.30
AA/AN/AAC/ANC/AFA	3	1.87	2.16	2.42	2.70	2.96	3.20	1.51	1.69	1.88	2.06	2.23	2.38	1.01	1.13	1.26	1.38	1.49	1.60
AA/AN/AAC/ANC/AFA	4	2.22	2.57	2.87	3.21	3.51	3.79	1.79	2.00	2.24	2.45	2.65	2.83	1.20	1.34	1.50	1.64	1.77	1.89
AA/AN/AAC/ANC/AFA	5	3.04	3.51	3.92	4.39	4.80	5.19	2.45	2.74	3.06	3.35	3.62	3.87	1.64	1.83	2.05	2.24	2.42	2.59

Refrigerant liquid temperature correction factors

	Refrigerant liquid temperature °f															
	0	10	20	30	40	50	60	70	80	90	100	110	120	130	140	
R-290	1.70	1.63	1.56	1.49	1.42	1.36	1.29	1.22	1.14	1.07	1.00	0.93	0.85	0.78	0.70	

NOTE: These factors include corrections for liquid refrigerant density and net refrigerating effect and are based on an average evaporator temperature of 0°F. However, they may be used for any evaporator temperature from -40°F to +40°F since the variation in the actual factors across this range is insignificant.

R-404a / R-507 conventional ported valves (tons) A-Series / AFA Series / T Series

Valve type	Nom. rating	Evaporator temperature																	
		50°F						40°F						20°F					
		Pressure drop across valve (psi)						Pressure drop across valve (psi)						Pressure drop across valve (psi)					
		60	80	100	125	150	175	60	80	100	125	150	175	60	80	100	125	150	175
AA/AN/AFA	1/8	0.14	0.16	0.18	0.20	0.22	0.24	0.14	0.16	0.18	0.20	0.22	0.24	0.13	0.15	0.17	0.19	0.21	0.22
AA/AN/AAC/ANC/AFA	1/4	0.25	0.29	0.32	0.36	0.40	0.43	0.24	0.28	0.31	0.35	0.38	0.41	0.23	0.27	0.30	0.33	0.36	0.39
AA/AN/AAC/ANC/AFA	1/2	0.43	0.50	0.56	0.62	0.68	0.73	0.43	0.50	0.56	0.62	0.68	0.73	0.41	0.47	0.53	0.59	0.65	0.70
AA/AN/AAC/ANC/AFA	3/4	0.70	0.81	0.90	1.01	1.11	1.20	0.68	0.79	0.88	0.98	1.08	1.16	0.65	0.75	0.84	0.94	1.03	1.11
AA/AN/AAC/ANC/AFA	1	1.00	1.15	1.29	1.44	1.58	1.71	0.98	1.13	1.27	1.41	1.55	1.67	0.93	1.07	1.20	1.34	1.47	1.59
AA/AN/AAC/ANC/AFA	1-1/2	1.47	1.70	1.90	2.12	2.32	2.51	1.44	1.66	1.86	2.08	2.28	2.46	1.38	1.59	1.78	1.99	2.18	2.36
AA/AN/AAC/ANC/AFA	2	2.06	2.38	2.66	2.97	3.26	3.52	2.02	2.33	2.61	2.92	3.19	3.45	1.93	2.23	2.49	2.79	3.05	3.30
AA/AN/AAC/ANC/AFA	2-1/2	2.53	2.92	3.27	3.65	4.00	4.32	2.47	2.85	3.19	3.57	3.91	4.22	2.37	2.74	3.06	3.42	3.75	4.05
AA/AN/AAC/ANC/AFA	3	3.00	3.46	3.87	4.33	4.74	5.12	2.94	3.39	3.80	4.24	4.65	5.02	2.81	3.24	3.63	4.06	4.44	4.80
AA/AN/AAC/ANC/AFA	4	4.10	4.73	5.29	5.92	6.48	7.00	4.02	4.64	5.19	5.80	6.36	6.87	3.84	4.43	4.96	5.54	6.07	6.56
TCLE	1/4	0.37	0.43	0.48	0.53	0.59	0.63	0.37	0.43	0.48	0.53	0.59	0.63	0.35	0.40	0.45	0.51	0.55	0.60
TCLE	3/4	0.70	0.81	0.90	1.01	1.11	1.20	0.69	0.80	0.89	1.00	1.09	1.18	0.66	0.76	0.85	0.95	1.04	1.13
TCLE	1-1/2	1.42	1.64	1.83	2.05	2.25	2.43	1.39	1.61	1.79	2.01	2.20	2.37	1.33	1.54	1.72	1.92	2.10	2.27
TCLE	2-1/2	2.62	3.03	3.38	3.78	4.14	4.47	2.57	2.97	3.32	3.71	4.06	4.39	2.46	2.84	3.18	3.55	3.89	4.20
TCLE	3-1/2	3.82	4.41	4.93	5.51	6.04	6.52	3.74	4.32	4.83	5.40	5.91	6.39	3.58	4.13	4.62	5.17	5.66	6.11
TCLE	5-1/2	5.55	6.41	7.17	8.01	8.78	9.48	5.43	6.27	7.01	7.84	8.59	9.27	5.20	6.00	6.71	7.51	8.22	8.88
TCLE	7-1/2	7.65	8.83	9.88	11.04	12.10	13.06	7.49	8.65	9.67	10.81	11.84	12.79	7.16	8.27	9.24	10.33	11.32	12.23
TCLE	9	9.22	10.65	11.90	13.31	14.58	15.75	9.03	10.43	11.66	13.03	14.28	15.42	8.64	9.98	11.15	12.47	13.66	14.76
TJL	9	8.17	9.43	10.55	11.79	12.92	13.95	8.00	9.24	10.33	11.55	12.65	13.66	7.65	8.83	9.88	11.04	12.10	13.06
TJL	11	10.42	12.03	13.45	15.04	16.48	17.80	10.20	11.78	13.17	14.72	16.13	17.42	9.76	11.27	12.60	14.09	15.43	16.67

NOTE: Standard capacity is rated at 100°F liquid inlet and 40°F evaporator temperature; with 100 PSI pressure drop across the TXV per ARI 750-2001.

Valve type	Nom. rating	Evaporator temperature																	
		0°F						-20°F						-40°F					
		Pressure drop across valve (psi)						Pressure drop across valve (psi)						Pressure drop across valve (psi)					
		60	80	100	125	150	175	80	100	125	150	175	200	80	100	125	150	175	200
AA/AN/AFA	1/8	0.09	0.10	0.12	0.13	0.14	0.15	0.07	0.08	0.09	0.10	0.10	0.11	0.05	0.06	0.06	0.07	0.07	0.08
AA/AN/AAC/ANC/AFA	1/4	0.16	0.18	0.21	0.23	0.25	0.27	0.12	0.13	0.15	0.16	0.18	0.19	0.08	0.09	0.10	0.11	0.12	0.13
AA/AN/AAC/ANC/AFA	1/2	0.28	0.32	0.36	0.40	0.44	0.48	0.22	0.25	0.28	0.30	0.33	0.35	0.14	0.16	0.18	0.19	0.21	0.22
AA/AN/AAC/ANC/AFA	3/4	0.44	0.51	0.57	0.64	0.70	0.75	0.35	0.39	0.44	0.48	0.52	0.55	0.23	0.26	0.29	0.31	0.34	0.36
AA/AN/AAC/ANC/AFA	1	0.63	0.73	0.81	0.91	1.00	1.08	0.50	0.56	0.63	0.68	0.74	0.79	0.32	0.36	0.40	0.44	0.47	0.51
AA/AN/AAC/ANC/AFA	1-1/4	0.93	1.07	1.20	1.34	1.47	1.59	0.73	0.82	0.91	1.00	1.08	1.15	0.48	0.54	0.60	0.66	0.71	0.76
AA/AN/AAC/ANC/AFA	2	1.31	1.51	1.69	1.89	2.07	2.24	1.03	1.15	1.29	1.41	1.52	1.63	0.67	0.75	0.84	0.92	0.99	1.06
AA/AN/AAC/ANC/AFA	2-1/4	1.61	1.86	2.08	2.32	2.55	2.75	1.26	1.41	1.58	1.73	1.86	1.99	0.82	0.92	1.03	1.12	1.21	1.30
AA/AN/AAC/ANC/AFA	2-1/2	1.91	2.21	2.47	2.76	3.02	3.26	1.50	1.68	1.88	2.05	2.22	2.37	0.98	1.10	1.23	1.34	1.45	1.55
AA/AN/AAC/ANC/AFA	3-1/2	2.61	3.01	3.37	3.77	4.13	4.46	2.04	2.28	2.55	2.79	3.02	3.23	1.34	1.50	1.68	1.83	1.98	2.12
TCLE	1/4	0.24	0.28	0.31	0.35	0.38	0.41	0.19	0.21	0.24	0.26	0.28	0.30	0.12	0.13	0.15	0.16	0.18	0.19
TCLE	1/2	0.45	0.52	0.58	0.65	0.71	0.77	0.35	0.39	0.44	0.48	0.52	0.55	0.23	0.26	0.29	0.31	0.34	0.36
TCLE	1	0.91	1.05	1.17	1.31	1.44	1.55	0.71	0.79	0.89	0.97	1.05	1.12	0.46	0.51	0.58	0.63	0.68	0.73
TCLE	2	1.67	1.93	2.16	2.41	2.64	2.85	1.31	1.46	1.64	1.79	1.94	2.07	0.86	0.96	1.08	1.18	1.27	1.36
TCLE	3	2.43	2.81	3.14	3.51	3.84	4.15	1.91	2.14	2.39	2.62	2.82	3.02	1.25	1.40	1.56	1.71	1.85	1.98
TCLE	4-1/2	3.53	4.08	4.56	5.10	5.58	6.03	2.77	3.10	3.46	3.79	4.10	4.38	1.81	2.02	2.26	2.48	2.68	2.86
TCLE	7	4.86	5.61	6.27	7.01	7.68	8.30	3.81	4.26	4.76	5.22	5.64	6.02	2.49	2.78	3.11	3.41	3.68	3.94
TCLE	8	5.86	6.77	7.57	8.46	9.27	10.01	4.60	5.14	5.75	6.30	6.80	7.27	3.01	3.37	3.76	4.12	4.45	4.76
TJL	7	5.19	5.99	6.70	7.49	8.21	8.86	4.07	4.55	5.09	5.57	6.02	6.44	2.66	2.97	3.33	3.64	3.93	4.21
TJL	9	6.62	7.64	8.55	9.56	10.47	11.31	5.20	5.81	6.50	7.12	7.69	8.22	3.40	3.80	4.25	4.66	5.03	5.38

Refrigerant liquid temperature correction factors

	Refrigerant liquid temperature °f															
	0	10	20	30	40	50	60	70	80	90	100	110	120	130	140	
R-404A/R-507	2.00	1.90	1.80	1.70	1.60	1.50	1.40	1.30	1.20	1.10	1.00	0.90	0.80	0.70	0.50	

NOTE: These factors include corrections for liquid refrigerant density and net refrigerating effect and are based on an average evaporator temperature of 0°F. However, they may be used for any evaporator temperature from -40°F to +40°F since the variation in the actual factors across this range is insignificant.

R-407a conventional ported valves (tons) A Series / AFA Series

Valve type	Nom. rating	Evaporator temperature																	
		50°F						40°F						20°F					
		Pressure drop across valve (psi)						Pressure drop across valve (psi)						Pressure drop across valve (psi)					
		60	80	100	125	150	175	60	80	100	125	150	175	60	80	100	125	150	175
AA/AN/AFA	1/8	0.15	0.17	0.19	0.22	0.24	0.25	0.15	0.17	0.19	0.21	0.23	0.25	0.14	0.16	0.18	0.20	0.22	0.24
AA/AN/AAC/ANC	1/4	0.26	0.30	0.33	0.37	0.41	0.44	0.25	0.29	0.33	0.37	0.40	0.43	0.25	0.28	0.32	0.35	0.39	0.42
AA/AN/AAC/ANC/AFA	1/2	0.46	0.53	0.59	0.66	0.72	0.78	0.45	0.52	0.58	0.65	0.71	0.76	0.43	0.50	0.56	0.62	0.68	0.74
AA/AN/AAC/ANC/AFA	1	0.73	0.84	0.94	1.05	1.15	1.25	0.72	0.83	0.93	1.04	1.13	1.23	0.69	0.80	0.89	1.00	1.09	1.18
AA/AN/AAC/ANC/AFA	1-1/2	1.04	1.21	1.35	1.51	1.65	1.78	1.03	1.19	1.32	1.48	1.62	1.75	0.99	1.14	1.28	1.43	1.56	1.69
AA/AN/AAC/ANC/AFA	2	1.54	1.78	1.99	2.22	2.43	2.63	1.51	1.75	1.95	2.18	2.39	2.58	1.46	1.68	1.88	2.10	2.30	2.49
AA/AN/AAC/ANC/AFA	2-1/2	2.16	2.49	2.79	3.11	3.41	3.69	2.12	2.45	2.74	3.06	3.36	3.62	2.04	2.36	2.64	2.95	3.23	3.49
AA/AN/AAC/ANC/AFA	3-1/2	2.64	3.05	3.41	3.82	4.18	4.52	2.60	3.00	3.36	3.75	4.11	4.44	2.51	2.89	3.23	3.62	3.96	4.28
AA/AN/AAC/ANC/AFA	4	3.14	3.62	4.05	4.53	4.96	5.36	3.09	3.56	3.98	4.46	4.88	5.27	2.97	3.43	3.84	4.29	4.70	5.08
AA/AN/AAC/ANC/AFA	5-1/2	4.29	4.96	5.54	6.20	6.79	7.33	4.22	4.87	5.45	6.09	6.67	7.21	4.07	4.70	5.25	5.87	6.43	6.94

Valve type	Nom. rating	Evaporator temperature																	
		0°F						-20°F						-40°F					
		Pressure drop across valve (psi)						Pressure drop across valve (psi)						Pressure drop across valve (psi)					
		60	80	100	125	150	175	80	100	125	150	175	200	80	100	125	150	175	200
AA/AN/AFA	1/8	0.13	0.15	0.17	0.19	0.20	0.22	0.10	0.11	0.12	0.14	0.15	0.16	0.06	0.07	0.08	0.09	0.09	0.10
AA/AN/AAC/ANC	1/4	0.22	0.26	0.29	0.32	0.35	0.38	0.17	0.19	0.22	0.24	0.26	0.27	0.11	0.12	0.14	0.15	0.16	0.17
AA/AN/AAC/ANC/AFA	1/2	0.39	0.46	0.51	0.57	0.62	0.67	0.30	0.34	0.38	0.42	0.45	0.48	0.19	0.21	0.24	0.26	0.28	0.30
AA/AN/AAC/ANC/AFA	1	0.63	0.73	0.82	0.91	1.00	1.08	0.49	0.54	0.61	0.67	0.72	0.77	0.31	0.34	0.39	0.42	0.46	0.49
AA/AN/AAC/ANC/AFA	1-1/2	0.90	1.04	1.17	1.31	1.43	1.55	0.70	0.78	0.87	0.95	1.03	1.10	0.44	0.49	0.55	0.60	0.65	0.70
AA/AN/AAC/ANC/AFA	2	1.33	1.54	1.72	1.92	2.11	2.28	1.03	1.15	1.28	1.40	1.52	1.62	0.65	0.73	0.81	0.89	0.96	1.03
AA/AN/AAC/ANC/AFA	2-1/2	1.87	2.16	2.42	2.70	2.96	3.20	1.44	1.61	1.80	1.97	2.13	2.27	0.91	1.02	1.14	1.25	1.35	1.44
AA/AN/AAC/ANC/AFA	3-1/2	2.29	2.65	2.96	3.31	3.63	3.92	1.76	1.97	2.20	2.41	2.61	2.79	1.12	1.25	1.40	1.53	1.65	1.77
AA/AN/AAC/ANC/AFA	4	2.72	3.14	3.51	3.93	4.30	4.65	2.09	2.34	2.62	2.87	3.10	3.31	1.33	1.48	1.66	1.81	1.96	2.10
AA/AN/AAC/ANC/AFA	5-1/2	3.72	4.30	4.80	5.37	5.88	6.36	2.86	3.20	3.58	3.92	4.23	4.52	1.81	2.03	2.27	2.48	2.68	2.87

Refrigerant liquid temperature correction factors

	Refrigerant liquid temperature °f															
	0	10	20	30	40	50	60	70	80	90	100	110	120	130	140	
R-407A	1.78	1.70	1.63	1.55	1.47	1.40	1.32	1.24	1.16	1.08	1.00	0.92	0.83	0.75	0.66	

NOTE: These factors include corrections for liquid refrigerant density and net refrigeration effect, and are based on an average evaporator temperature of 0°F with a maximum 7°F Change in Superheat. However, they may be used for any evaporator temperature from -40°F to +40°F since the variation in the actual factors across this range is insignificant.

R-407c conventional ported valves (tons) A Series / AFA Series / T Series

Valve type	Nom. rating	Evaporator temperature																	
		50°F						40°F						20°F					
		Pressure drop across valve (psi)						Pressure drop across valve (psi)						Pressure drop across valve (psi)					
		60	80	100	125	150	175	60	80	100	125	150	175	60	80	100	125	150	175
AA/AN/AFA	1/5	0.14	0.16	0.18	0.20	0.22	0.24	0.14	0.16	0.18	0.20	0.22	0.24	0.14	0.16	0.18	0.20	0.22	0.24
AA/AN/AAC/ANC/AFA	1/4	0.25	0.29	0.32	0.36	0.40	0.43	0.24	0.28	0.31	0.35	0.38	0.41	0.23	0.27	0.30	0.33	0.36	0.39
AA/AN/AAC/ANC/AFA	1/2	0.44	0.51	0.57	0.64	0.70	0.75	0.43	0.50	0.56	0.62	0.68	0.73	0.41	0.47	0.53	0.59	0.65	0.70
AA/AN/AAC/ANC/AFA	1	0.70	0.81	0.90	1.01	1.11	1.20	0.69	0.80	0.89	1.00	1.09	1.18	0.66	0.76	0.85	0.95	1.04	1.13
AA/AN/AAC/ANC/AFA	1-1/4	1.00	1.15	1.29	1.44	1.58	1.71	0.98	1.13	1.27	1.41	1.55	1.67	0.95	1.10	1.23	1.37	1.50	1.62
AA/AN/AAC/ANC/AFA	2	1.48	1.71	1.91	2.14	2.34	2.53	1.45	1.67	1.87	2.09	2.29	2.48	1.39	1.61	1.79	2.01	2.20	2.37
AA/AN/AAC/ANC/AFA	2-1/2	2.07	2.39	2.67	2.99	3.27	3.54	2.04	2.36	2.63	2.94	3.23	3.48	1.95	2.25	2.52	2.81	3.08	3.33
AA/AN/AAC/ANC/AFA	3-1/4	2.54	2.93	3.28	3.67	4.02	4.34	2.49	2.88	3.21	3.59	3.94	4.25	2.39	2.76	3.09	3.45	3.78	4.08
AA/AN/AAC/ANC/AFA	4	3.02	3.49	3.90	4.36	4.78	5.16	2.96	3.42	3.82	4.27	4.68	5.06	2.84	3.28	3.67	4.10	4.49	4.85
AA/AN/AAC/ANC/AFA	5-1/4	4.12	4.76	5.32	5.95	6.51	7.04	4.05	4.68	5.23	5.85	6.40	6.92	3.89	4.49	5.02	5.61	6.15	6.64
TCLE	1/2	0.38	0.44	0.49	0.55	0.60	0.65	0.37	0.43	0.48	0.53	0.59	0.63	0.36	0.42	0.46	0.52	0.57	0.61
TCLE	1	0.71	0.82	0.92	1.02	1.12	1.21	0.70	0.81	0.90	1.01	1.11	1.20	0.67	0.77	0.86	0.97	1.06	1.14
TCLE	2	1.43	1.65	1.85	2.06	2.26	2.44	1.41	1.63	1.82	2.04	2.23	2.41	1.35	1.56	1.74	1.95	2.13	2.31
TCLE	3	2.64	3.05	3.41	3.81	4.17	4.51	2.59	2.99	3.34	3.74	4.10	4.42	2.49	2.88	3.21	3.59	3.94	4.25
TCLE	5	3.85	4.45	4.97	5.56	6.09	6.58	3.77	4.35	4.87	5.44	5.96	6.44	3.62	4.18	4.67	5.23	5.72	6.18
TCLE	7-1/2	5.58	6.44	7.20	8.05	8.82	9.53	5.48	6.33	7.07	7.91	8.66	9.36	5.26	6.07	6.79	7.59	8.32	8.98
TCLE	10	7.69	8.88	9.93	11.10	12.16	13.13	7.55	8.72	9.75	10.90	11.94	12.89	7.25	8.37	9.36	10.46	11.46	12.38
TCLE	12	9.27	10.70	11.97	13.38	14.66	15.83	9.10	10.51	11.75	13.13	14.39	15.54	8.74	10.09	11.28	12.62	13.82	14.93
TJL	11	8.22	9.49	10.61	11.86	13.00	14.04	8.07	9.32	10.42	11.65	12.76	13.78	7.75	8.95	10.01	11.19	12.25	13.24
TJL	14	10.48	12.10	13.53	15.13	16.57	17.90	10.29	11.88	13.28	14.85	16.27	17.57	9.88	11.41	12.76	14.26	15.62	16.87

NOTE: Standard capacity is rated at 100°F liquid inlet and 40°F evaporator temperature; with 100 PSI pressure drop across the TXV per ARI 750-2001.

Valve type	Nom. rating	Evaporator temperature																	
		0°F						-20°F						-40°F					
		Pressure drop across valve (psi)						Pressure drop across valve (psi)						Pressure drop across valve (psi)					
		60	80	100	125	150	175	80	100	125	150	175	200	80	100	125	150	175	200
AA/AN/AFA	1/5	0.11	0.13	0.14	0.16	0.17	0.19	0.09	0.10	0.11	0.12	0.13	0.14	0.05	0.06	0.06	0.07	0.07	0.08
AA/AN/AAC/ANC/AFA	1/4	0.20	0.23	0.26	0.29	0.32	0.34	0.15	0.17	0.19	0.21	0.22	0.24	0.09	0.10	0.11	0.12	0.13	0.14
AA/AN/AAC/ANC/AFA	1/2	0.35	0.40	0.45	0.51	0.55	0.60	0.26	0.29	0.33	0.36	0.38	0.41	0.17	0.19	0.21	0.23	0.25	0.27
AA/AN/AAC/ANC/AFA	1	0.56	0.65	0.72	0.81	0.89	0.96	0.42	0.47	0.53	0.58	0.62	0.66	0.27	0.30	0.34	0.37	0.40	0.43
AA/AN/AAC/ANC/AFA	1-1/4	0.80	0.92	1.03	1.15	1.26	1.37	0.61	0.68	0.76	0.84	0.90	0.96	0.38	0.42	0.48	0.52	0.56	0.60
AA/AN/AAC/ANC/AFA	2	1.18	1.36	1.52	1.70	1.87	2.02	0.90	1.01	1.13	1.23	1.33	1.42	0.56	0.63	0.70	0.77	0.83	0.89
AA/AN/AAC/ANC/AFA	2-1/2	1.65	1.91	2.13	2.38	2.61	2.82	1.26	1.41	1.58	1.73	1.86	1.99	0.79	0.88	0.99	1.08	1.17	1.25
AA/AN/AAC/ANC/AFA	3-1/4	2.02	2.33	2.61	2.92	3.19	3.45	1.54	1.72	1.93	2.11	2.28	2.43	0.97	1.08	1.21	1.33	1.43	1.53
AA/AN/AAC/ANC/AFA	4	2.40	2.77	3.10	3.46	3.79	4.10	1.83	2.05	2.29	2.51	2.71	2.89	1.15	1.29	1.44	1.57	1.70	1.82
AA/AN/AAC/ANC/AFA	5-1/4	3.28	3.79	4.23	4.73	5.19	5.60	2.50	2.80	3.13	3.42	3.70	3.95	1.57	1.76	1.96	2.15	2.32	2.48
TCLE	1/2	0.30	0.35	0.39	0.43	0.47	0.51	0.23	0.26	0.29	0.31	0.34	0.36	0.14	0.16	0.18	0.19	0.21	0.22
TCLE	1	0.56	0.65	0.72	0.81	0.89	0.96	0.43	0.48	0.54	0.59	0.64	0.68	0.27	0.30	0.34	0.37	0.40	0.43
TCLE	2	1.14	1.32	1.47	1.65	1.80	1.95	0.87	0.97	1.09	1.19	1.29	1.38	0.55	0.61	0.69	0.75	0.81	0.87
TCLE	3	2.10	2.42	2.71	3.03	3.32	3.59	1.60	1.79	2.00	2.19	2.37	2.53	1.01	1.13	1.26	1.38	1.49	1.60
TCLE	5	3.06	3.53	3.95	4.42	4.84	5.23	2.33	2.61	2.91	3.19	3.45	3.68	1.47	1.64	1.84	2.01	2.17	2.32
TCLE	7-1/2	4.44	5.13	5.73	6.41	7.02	7.58	3.38	3.78	4.23	4.63	5.00	5.34	2.13	2.38	2.66	2.92	3.15	3.37
TCLE	10	6.12	7.07	7.90	8.83	9.68	10.45	4.66	5.21	5.83	6.38	6.89	7.37	2.93	3.28	3.66	4.01	4.33	4.63
TCLE	12	7.38	8.52	9.53	10.65	11.67	12.60	5.62	6.28	7.03	7.70	8.31	8.89	3.54	3.96	4.43	4.85	5.24	5.60
TJL	11	6.54	7.55	8.44	9.44	10.34	11.17	4.98	5.57	6.23	6.82	7.37	7.87	3.13	3.50	3.91	4.29	4.63	4.95
TJL	14	8.34	9.63	10.77	12.04	13.19	14.24	6.35	7.10	7.94	8.70	9.39	10.04	4.00	4.47	5.00	5.48	5.92	6.32

Refrigerant liquid temperature correction factors

	Refrigerant liquid temperature °f														
	0	10	20	30	40	50	60	70	80	90	100	110	120	130	140
R-407C	1.72	1.65	1.58	1.51	1.44	1.37	1.29	1.22	1.15	1.07	1.00	0.92	0.85	0.77	0.69

NOTE: These factors include corrections for liquid refrigerant density and net refrigerating effect and are based on an average evaporator temperature of 0°F. However, they may be used for any evaporator temperature from -40°F to +40°F since the variation in the actual factors across this range is insignificant.

R-407h conventional ported valves (tons) A Series

Valve type	Nom. rating	Evaporator temperature																	
		50°F						40°F						20°F					
		Pressure drop across valve (psi)						Pressure drop across valve (psi)						Pressure drop across valve (psi)					
		60	80	100	125	150	175	60	80	100	125	150	175	60	80	100	125	150	175
AA/AN/AFA	1/4	0.18	0.20	0.23	0.25	0.28	0.30	0.17	0.20	0.22	0.25	0.27	0.30	0.17	0.19	0.22	0.24	0.27	0.29
AA/AN/AAC/ANC	1/2	0.31	0.35	0.40	0.44	0.48	0.52	0.30	0.35	0.39	0.44	0.48	0.52	0.29	0.34	0.38	0.42	0.46	0.50
AA/AN/AAC/ANC/AFA	3/4	0.54	0.62	0.69	0.78	0.85	0.92	0.53	0.61	0.68	0.77	0.84	0.91	0.51	0.59	0.66	0.74	0.81	0.88
AA/AN/AAC/ANC/AFA	1	0.86	1.00	1.11	1.24	1.36	1.47	0.85	0.98	1.10	1.23	1.34	1.45	0.82	0.95	1.06	1.19	1.30	1.41
AA/AN/AAC/ANC/AFA	1-1/2	1.23	1.42	1.59	1.78	1.95	2.11	1.22	1.40	1.57	1.76	1.92	2.08	1.18	1.36	1.52	1.70	1.86	2.01
AA/AN/AAC/ANC/AFA	2-1/4	1.82	2.10	2.35	2.62	2.87	3.10	1.79	2.07	2.31	2.59	2.83	3.06	1.74	2.01	2.24	2.51	2.75	2.97
AA/AN/AAC/ANC/AFA	3-1/4	2.55	2.94	3.29	3.68	4.03	4.35	2.51	2.90	3.25	3.63	3.98	4.29	2.44	2.82	3.15	3.52	3.86	4.16
AA/AN/AAC/ANC/AFA	4	3.12	3.61	4.03	4.51	4.94	5.34	3.08	3.56	3.98	4.45	4.87	5.26	2.99	3.45	3.86	4.31	4.73	5.10
AA/AN/AAC/ANC/AFA	4-3/4	3.71	4.28	4.79	5.35	5.86	6.33	3.66	4.22	4.72	5.28	5.78	6.25	3.55	4.10	4.58	5.12	5.61	6.06
AA/AN/AAC/ANC/AFA	6-1/2	5.07	5.86	6.55	7.32	8.02	8.66	5.00	5.78	6.46	7.22	7.91	8.54	4.85	5.60	6.26	7.00	7.67	8.28

Valve type	Nom. rating	Evaporator temperature																	
		0°F						-20°F						-40°F					
		Pressure drop across valve (psi)						Pressure drop across valve (psi)						Pressure drop across valve (psi)					
		60	80	100	125	150	175	80	100	125	150	175	200	80	100	125	150	175	200
AA/AN/AFA	1/4	0.15	0.17	0.19	0.22	0.24	0.26	0.12	0.13	0.14	0.16	0.17	0.18	0.07	0.08	0.09	0.10	0.11	0.12
AA/AN/AAC/ANC	1/2	0.26	0.30	0.34	0.38	0.41	0.45	0.20	0.23	0.25	0.28	0.30	0.32	0.13	0.14	0.16	0.18	0.19	0.20
AA/AN/AAC/ANC/AFA	3/4	0.46	0.53	0.59	0.66	0.72	0.78	0.35	0.40	0.44	0.48	0.52	0.56	0.23	0.25	0.28	0.31	0.33	0.36
AA/AN/AAC/ANC/AFA	1	0.74	0.85	0.95	1.06	1.16	1.26	0.57	0.63	0.71	0.78	0.84	0.90	0.36	0.40	0.45	0.49	0.53	0.57
AA/AN/AAC/ANC/AFA	1-1/2	1.05	1.21	1.36	1.52	1.66	1.80	0.81	0.91	1.01	1.11	1.20	1.28	0.52	0.58	0.65	0.71	0.76	0.82
AA/AN/AAC/ANC/AFA	2-1/4	1.55	1.79	2.00	2.24	2.45	2.65	1.20	1.34	1.49	1.64	1.77	1.89	0.76	0.85	0.95	1.04	1.12	1.20
AA/AN/AAC/ANC/AFA	3-1/4	2.17	2.51	2.81	3.14	3.44	3.71	1.68	1.88	2.10	2.30	2.48	2.65	1.07	1.19	1.33	1.46	1.58	1.69
AA/AN/AAC/ANC/AFA	4	2.66	3.08	3.44	3.84	4.21	4.55	2.06	2.30	2.57	2.81	3.04	3.25	1.31	1.46	1.63	1.79	1.93	2.07
AA/AN/AAC/ANC/AFA	4-3/4	3.16	3.65	4.08	4.56	5.00	5.40	2.44	2.73	3.05	3.34	3.61	3.86	1.55	1.74	1.94	2.13	2.30	2.45
AA/AN/AAC/ANC/AFA	6-1/2	4.32	4.99	5.58	6.24	6.84	7.38	3.34	3.73	4.17	4.57	4.94	5.28	2.12	2.37	2.65	2.91	3.14	3.36

Refrigerant liquid temperature correction factors

	Refrigerant liquid temperature °f															
	0	10	20	30	40	50	60	70	80	90	100	110	120	130	140	
R-407H	1.65	1.59	1.52	1.46	1.40	1.33	1.27	1.20	1.13	1.07	1.00	0.93	0.86	0.79	0.71	

NOTE: These factors include corrections for liquid refrigerant density and net refrigeration effect, and are based on an average evaporator temperature of 0°F with a maximum 7°F Change in Superheat. However, they may be used for any evaporator temperature from -40°F to +40°F since the variation in the actual factors across this range is insignificant.

R-410a conventional ported valves (tons) A Series / AFA Series

Valve type	Nom. rating	Evaporator temperature																	
		50°F						40°F						20°F					
		Pressure drop across valve (psi)						Pressure drop across valve (psi)						Pressure drop across valve (psi)					
		110	140	160	210	245	285	110	140	160	210	245	285	110	140	160	210	245	285
AA/AN/AAC/ANC/AFA	1/4	0.34	0.38	0.41	0.47	0.51	0.55	0.34	0.38	0.41	0.47	0.51	0.55	0.33	0.37	0.40	0.46	0.49	0.53
AA/AN/AAC/ANC/AFA	1/2	0.60	0.68	0.72	0.83	0.90	0.97	0.59	0.67	0.71	0.82	0.88	0.95	0.58	0.65	0.70	0.80	0.87	0.93
AA/AN/AAC/ANC/AFA	1	0.96	1.08	1.16	1.33	1.43	1.55	0.95	1.07	1.15	1.31	1.42	1.53	0.93	1.05	1.12	1.28	1.39	1.50
AA/AN/AAC/ANC/AFA	1-1/2	1.38	1.56	1.66	1.91	2.06	2.22	1.36	1.53	1.64	1.88	2.03	2.19	1.33	1.50	1.60	1.84	1.98	2.14
AA/AN/AAC/ANC/AFA	2	2.03	2.29	2.45	2.80	3.03	3.27	2.01	2.27	2.42	2.78	3.00	3.24	1.96	2.21	2.36	2.71	2.93	3.15
AA/AN/AAC/ANC/AFA	3	2.85	3.22	3.44	3.94	4.25	4.59	2.82	3.18	3.40	3.90	4.21	4.54	2.74	3.09	3.30	3.79	4.09	4.41
AA/AN/AAC/ANC/AFA	4	3.49	3.94	4.21	4.82	5.21	5.62	3.45	3.89	4.16	4.77	5.15	5.55	3.36	3.79	4.05	4.64	5.01	5.41
AA/AN/AAC/ANC/AFA	5	4.14	4.67	4.99	5.72	6.18	6.66	4.10	4.63	4.94	5.66	6.12	6.60	3.99	4.50	4.81	5.51	5.95	6.42

NOTE: Standard capacity is rated at 100°F liquid inlet and 40°F evaporator temperature; with 100 PSI pressure drop across the TXV per ARI 750-2001.

Valve type	Nom. rating	Evaporator temperature																	
		0°F						-20°F						-40°F					
		Pressure drop across valve (psi)						Pressure drop across valve (psi)						Pressure drop across valve (psi)					
		140	160	210	245	285	330	140	160	210	245	285	330	140	160	210	245	285	330
AA/AN/AAC/ANC/AFA	1/4	0.34	0.36	0.42	0.45	0.49	0.52	0.24	0.26	0.29	0.32	0.34	0.37	0.16	0.17	0.20	0.21	0.23	0.25
AA/AN/AAC/ANC/AFA	1/2	0.60	0.64	0.73	0.79	0.86	0.92	0.41	0.44	0.50	0.54	0.58	0.63	0.27	0.29	0.33	0.36	0.39	0.41
AA/AN/AAC/ANC/AFA	1	0.95	1.02	1.16	1.26	1.36	1.46	0.66	0.71	0.81	0.87	0.94	1.01	0.44	0.47	0.54	0.58	0.63	0.68
AA/AN/AAC/ANC/AFA	1-1/2	1.36	1.45	1.67	1.80	1.94	2.09	0.95	1.02	1.16	1.26	1.36	1.46	0.63	0.67	0.77	0.83	0.90	0.97
AA/AN/AAC/ANC/AFA	2	2.01	2.15	2.46	2.66	2.87	3.09	1.40	1.50	1.71	1.85	2.00	2.15	0.93	0.99	1.14	1.23	1.33	1.43
AA/AN/AAC/ANC/AFA	3	2.82	3.01	3.45	3.73	4.02	4.33	1.96	2.10	2.40	2.59	2.80	3.01	1.30	1.39	1.59	1.72	1.85	2.00
AA/AN/AAC/ANC/AFA	4	3.46	3.70	4.24	4.58	4.94	5.31	2.40	2.57	2.94	3.17	3.42	3.68	1.60	1.71	1.96	2.12	2.28	2.46
AA/AN/AAC/ANC/AFA	5	4.10	4.38	5.02	5.42	5.85	6.29	2.85	3.05	3.49	3.77	4.07	4.38	1.89	2.02	2.31	2.50	2.70	2.90

Refrigerant liquid temperature correction factors

	Refrigerant liquid temperature °f									
	50	60	70	80	90	100	110	120	130	140
R-410A	1.37	1.30	1.23	1.15	1.08	1.00	0.92	0.84	0.75	0.65
R-32	1.30	1.24	1.18	1.12	1.06	1.00	0.94	0.87	0.80	0.73

NOTE: These factors include corrections for liquid refrigerant density and net refrigeration effect, and are based on an average evaporator temperature of 0°F with a maximum 7°F Change in Superheat. However, they may be used for any evaporator temperature from -40°F to +40°F since the variation in the actual factors across this range is insignificant.

R-448a / R-449a conventional ported valves (tons) A Series / AFA Series

Valve type	Nom. rating	Evaporator temperature																	
		50°F						40°F						20°F					
		Pressure drop across valve (psi)						Pressure drop across valve (psi)						Pressure drop across valve (psi)					
		60	80	100	125	150	175	60	80	100	125	150	175	60	80	100	125	150	175
AA/AN/AAC/ANC/AFA	1/5	0.15	0.18	0.20	0.22	0.24	0.26	0.15	0.17	0.19	0.22	0.24	0.26	0.15	0.17	0.19	0.21	0.23	0.25
AA/AN/AAC/ANC/AFA	1/4	0.27	0.31	0.34	0.38	0.42	0.45	0.26	0.30	0.34	0.38	0.41	0.45	0.26	0.30	0.33	0.37	0.40	0.44
AA/AN/AAC/ANC/AFA	1/2	0.47	0.54	0.60	0.67	0.74	0.80	0.46	0.53	0.60	0.67	0.73	0.79	0.45	0.52	0.58	0.65	0.71	0.77
AA/AN/AAC/ANC/AFA	1	0.75	0.86	0.96	1.08	1.18	1.28	0.74	0.85	0.95	1.07	1.17	1.26	0.72	0.83	0.93	1.04	1.14	1.23
AA/AN/AAC/ANC/AFA	1-1/2	1.07	1.23	1.38	1.54	1.69	1.82	1.06	1.22	1.36	1.53	1.67	1.81	1.03	1.19	1.33	1.49	1.63	1.76
AA/AN/AAC/ANC/AFA	2	1.57	1.82	2.03	2.27	2.49	2.69	1.56	1.80	2.01	2.25	2.46	2.66	1.52	1.76	1.96	2.20	2.40	2.60
AA/AN/AAC/ANC/AFA	2-3/4	2.21	2.55	2.85	3.19	3.49	3.77	2.19	2.52	2.82	3.16	3.46	3.73	2.13	2.46	2.75	3.08	3.37	3.64
AA/AN/AAC/ANC/AFA	3-1/2	2.71	3.13	3.49	3.91	4.28	4.62	2.68	3.09	3.46	3.87	4.24	4.57	2.61	3.02	3.38	3.77	4.13	4.47
AA/AN/AAC/ANC/AFA	4	3.21	3.71	4.15	4.64	5.08	5.49	3.18	3.67	4.10	4.59	5.03	5.43	3.10	3.58	4.01	4.48	4.91	5.30
AA/AN/AAC/ANC/AFA	5-1/2	4.39	5.07	5.67	6.34	6.95	7.50	4.35	5.02	5.61	6.28	6.87	7.43	4.24	4.90	5.48	6.13	6.71	7.25

NOTE: Standard capacity is rated at 100°F liquid inlet and 40°F evaporator temperature; with 100 PSI pressure drop across the TXV.

Valve type	Nom. rating	Evaporator temperature																	
		0°F						-20°F						-40°F					
		Pressure drop across valve (psi)						Pressure drop across valve (psi)						Pressure drop across valve (psi)					
		60	80	100	125	150	175	80	100	125	150	175	200	80	100	125	150	175	200
AA/AN/AAC/ANC/AFA	1/5	0.14	0.17	0.19	0.21	0.23	0.24	0.13	0.15	0.16	0.18	0.19	0.21	0.09	0.10	0.11	0.12	0.13	0.14
AA/AN/AAC/ANC/AFA	1/4	0.25	0.29	0.32	0.36	0.39	0.43	0.23	0.25	0.28	0.31	0.34	0.36	0.15	0.17	0.19	0.21	0.23	0.24
AA/AN/AAC/ANC/AFA	1/2	0.44	0.51	0.57	0.63	0.69	0.75	0.40	0.45	0.50	0.55	0.59	0.63	0.27	0.30	0.34	0.37	0.40	0.43
AA/AN/AAC/ANC/AFA	1	0.70	0.81	0.91	1.01	1.11	1.20	0.64	0.72	0.80	0.88	0.95	1.01	0.43	0.48	0.54	0.59	0.64	0.68
AA/AN/AAC/ANC/AFA	1-1/2	1.00	1.16	1.30	1.45	1.59	1.71	0.92	1.02	1.15	1.26	1.36	1.45	0.62	0.69	0.77	0.85	0.92	0.98
AA/AN/AAC/ANC/AFA	2	1.48	1.71	1.91	2.14	2.34	2.53	1.35	1.51	1.69	1.85	2.00	2.14	0.91	1.02	1.14	1.25	1.35	1.44
AA/AN/AAC/ANC/AFA	2-3/4	2.08	2.40	2.68	3.00	3.28	3.54	1.90	2.12	2.37	2.60	2.80	3.00	1.28	1.43	1.60	1.75	1.89	2.02
AA/AN/AAC/ANC/AFA	3-1/2	2.54	2.94	3.28	3.67	4.02	4.34	2.32	2.60	2.90	3.18	3.44	3.67	1.57	1.75	1.96	2.15	2.32	2.48
AA/AN/AAC/ANC/AFA	4	3.02	3.49	3.90	4.36	4.77	5.16	2.76	3.08	3.45	3.77	4.08	4.36	1.86	2.08	2.33	2.55	2.75	2.94
AA/AN/AAC/ANC/AFA	5-1/2	4.13	4.77	5.33	5.96	6.53	7.05	3.77	4.21	4.71	5.16	5.58	5.96	2.55	2.85	3.18	3.49	3.76	4.02

Refrigerant liquid temperature correction factors

	Refrigerant liquid temperature °f															
	0	10	20	30	40	50	60	70	80	90	100	110	120	130	140	
R-448A/R-449A	1.71	1.64	1.57	1.50	1.43	1.36	1.29	1.22	1.15	1.07	1.00	0.92	0.85	0.77	0.69	

NOTE: These factors include corrections for liquid refrigerant density and net refrigeration effect, and are based on an average evaporator temperature of 0°F with a maximum 7°F Change in Superheat. However, they may be used for any evaporator temperature from -40°F to +40°F since the variation in the actual factors across this range is insignificant.

R-450a / R-513a conventional ported valves (tons) A Series / AFA Series

Valve type	Nom. rating	Evaporator temperature																	
		50°F						40°F						20°F					
		Pressure drop across valve (psi)						Pressure drop across valve (psi)						Pressure drop across valve (psi)					
		60	80	100	125	150	175	60	80	100	125	150	175	60	80	100	125	150	175
AA/AN/AAC/ANC/AFA	1/8	0.11	0.13	0.15	0.16	0.18	0.19	0.11	0.13	0.14	0.16	0.17	0.19	0.10	0.12	0.13	0.15	0.16	0.18
AA/AN/AAC/ANC/AFA	1/5	0.19	0.22	0.25	0.28	0.30	0.33	0.19	0.22	0.24	0.27	0.30	0.32	0.18	0.21	0.23	0.26	0.28	0.31
AA/AN/AAC/ANC/AFA	1/4	0.35	0.40	0.45	0.50	0.55	0.59	0.34	0.39	0.44	0.49	0.53	0.58	0.32	0.37	0.41	0.46	0.51	0.55
AA/AN/AAC/ANC/AFA	1/2	0.55	0.63	0.70	0.79	0.86	0.93	0.53	0.62	0.69	0.77	0.84	0.91	0.51	0.58	0.65	0.73	0.80	0.86
AA/AN/AAC/ANC/AFA	3/4	0.79	0.91	1.02	1.14	1.24	1.34	0.77	0.89	0.99	1.11	1.21	1.31	0.73	0.84	0.94	1.05	1.15	1.25
AA/AN/AAC/ANC/AFA	1	1.16	1.33	1.49	1.67	1.83	1.97	1.13	1.30	1.46	1.63	1.78	1.93	1.07	1.24	1.38	1.55	1.70	1.83
AA/AN/AAC/ANC/AFA	1-1/2	1.62	1.87	2.09	2.34	2.56	2.77	1.58	1.83	2.04	2.29	2.50	2.70	1.50	1.74	1.94	2.17	2.38	2.57
AA/AN/AAC/ANC/AFA	2	1.98	2.29	2.56	2.86	3.14	3.39	1.94	2.24	2.50	2.79	3.06	3.31	1.84	2.12	2.37	2.65	2.91	3.14
AA/AN/AAC/ANC/AFA	2-1/2	2.36	2.73	3.05	3.41	3.73	4.03	2.30	2.66	2.97	3.33	3.64	3.94	2.19	2.53	2.83	3.16	3.46	3.74
AA/AN/AAC/ANC/AFA	3	3.23	3.73	4.17	4.66	5.10	5.51	3.15	3.64	4.07	4.55	4.98	5.38	2.99	3.46	3.86	4.32	4.73	5.11

NOTE: Standard capacity is rated at 100°F liquid inlet and 40°F evaporator temperature; with 60 PSI pressure drop across the TXV.

Valve type	Nom. rating	Evaporator temperature																	
		0°F						-20°F						-40°F					
		Pressure drop across valve (psi)						Pressure drop across valve (psi)						Pressure drop across valve (psi)					
		60	80	100	125	150	175	80	100	125	150	175	200	80	100	125	150	175	200
AA/AN/AAC/ANC/AFA	1/8	0.08	0.09	0.10	0.11	0.12	0.13	0.06	0.06	0.07	0.08	0.08	0.09	0.03	0.04	0.04	0.04	0.05	0.05
AA/AN/AAC/ANC/AFA	1/5	0.13	0.15	0.17	0.19	0.21	0.22	0.10	0.11	0.12	0.13	0.15	0.16	0.06	0.06	0.07	0.08	0.08	0.09
AA/AN/AAC/ANC/AFA	1/4	0.23	0.27	0.30	0.34	0.37	0.40	0.18	0.20	0.22	0.24	0.26	0.28	0.10	0.11	0.13	0.14	0.15	0.16
AA/AN/AAC/ANC/AFA	1/2	0.37	0.42	0.47	0.53	0.58	0.63	0.28	0.31	0.35	0.38	0.41	0.44	0.16	0.18	0.20	0.22	0.24	0.25
AA/AN/AAC/ANC/AFA	3/4	0.53	0.61	0.68	0.76	0.84	0.90	0.40	0.45	0.50	0.55	0.59	0.63	0.23	0.26	0.29	0.31	0.34	0.36
AA/AN/AAC/ANC/AFA	1	0.78	0.90	1.00	1.12	1.23	1.33	0.59	0.66	0.74	0.81	0.87	0.93	0.34	0.38	0.42	0.46	0.50	0.53
AA/AN/AAC/ANC/AFA	1-1/2	1.09	1.26	1.41	1.58	1.73	1.86	0.83	0.93	1.03	1.13	1.22	1.31	0.47	0.53	0.59	0.65	0.70	0.75
AA/AN/AAC/ANC/AFA	2	1.33	1.54	1.72	1.93	2.11	2.28	1.01	1.13	1.26	1.39	1.50	1.60	0.58	0.65	0.72	0.79	0.85	0.91
AA/AN/AAC/ANC/AFA	2-1/2	1.59	1.83	2.05	2.29	2.51	2.71	1.20	1.35	1.51	1.65	1.78	1.90	0.69	0.77	0.86	0.94	1.02	1.09
AA/AN/AAC/ANC/AFA	3	2.17	2.51	2.80	3.14	3.44	3.71	1.65	1.84	2.06	2.25	2.44	2.60	0.94	1.05	1.17	1.29	1.39	1.49

Refrigerant liquid temperature correction factors

	Refrigerant liquid temperature °f															
	0	10	20	30	40	50	60	70	80	90	100	110	120	130	140	
R-450A/R-513A	1.73	1.65	1.58	1.51	1.44	1.36	1.29	1.22	1.15	1.07	1.00	0.93	0.85	0.78	0.70	

NOTE: These factors include corrections for liquid refrigerant density and net refrigeration effect, and are based on an average evaporator temperature of 0°F with a maximum 7°F Change in Superheat. However, they may be used for any evaporator temperature from -40°F to +40°F since the variation in the actual factors across this range is insignificant.

R-452a conventional ported valves (tons) - A Series

Valve type	Nom. rating	Evaporator temperature																	
		50°F						40°F						20°F					
		Pressure drop across valve (psi)						Pressure drop across valve (psi)						Pressure drop across valve (psi)					
		60	80	100	125	150	175	60	80	100	125	150	175	60	80	100	125	150	175
AA/AN/AAC/ANC/AFA	1/5	0.11	0.13	0.15	0.16	0.18	0.19	0.11	0.13	0.14	0.16	0.18	0.19	0.11	0.12	0.14	0.15	0.17	0.18
AA/AN/AAC/ANC/AFA	1/4	0.20	0.23	0.26	0.29	0.31	0.34	0.19	0.22	0.25	0.28	0.31	0.33	0.18	0.21	0.24	0.26	0.29	0.31
AA/AN/AAC/ANC/AFA	1/2	0.35	0.40	0.45	0.50	0.55	0.59	0.34	0.39	0.44	0.49	0.54	0.58	0.32	0.37	0.42	0.46	0.51	0.55
AA/AN/AAC/ANC/AFA	1	0.56	0.64	0.72	0.80	0.88	0.95	0.54	0.63	0.70	0.79	0.86	0.93	0.52	0.60	0.67	0.74	0.82	0.88
AA/AN/AAC/ANC/AFA	1-1/2	0.80	0.92	1.03	1.15	1.26	1.36	0.78	0.90	1.00	1.12	1.23	1.33	0.74	0.85	0.95	1.07	1.17	1.26
AA/AN/AAC/ANC/AFA	2	1.17	1.36	1.52	1.70	1.86	2.01	1.15	1.32	1.48	1.66	1.81	1.96	1.09	1.26	1.40	1.57	1.72	1.86
AA/AN/AAC/ANC/AFA	2-3/4	1.65	1.90	2.13	2.38	2.61	2.81	1.61	1.86	2.08	2.32	2.54	2.75	1.53	1.76	1.97	2.20	2.41	2.61
AA/AN/AAC/ANC/AFA	3-1/2	2.02	2.33	2.61	2.91	3.19	3.45	1.97	2.28	2.55	2.85	3.12	3.37	1.87	2.16	2.41	2.70	2.96	3.19
AA/AN/AAC/ANC/AFA	4	2.40	2.77	3.09	3.46	3.79	4.09	2.34	2.70	3.02	3.38	3.70	4.00	2.22	2.56	2.86	3.20	3.51	3.79
AA/AN/AAC/ANC/AFA	5-1/2	3.28	3.78	4.23	4.73	5.18	5.60	3.20	3.70	4.13	4.62	5.06	5.47	3.03	3.50	3.92	4.38	4.80	5.18

NOTE: Standard capacity is rated at 100F liquid inlet and 40F evaporator temperature; with 100 PSI pressure drop across the TXV.

Valve type	Nom. rating	Evaporator temperature																	
		0°F						-20°F						-40°F					
		Pressure drop across valve (psi)						Pressure drop across valve (psi)						Pressure drop across valve (psi)					
		60	80	100	125	150	175	80	100	125	150	175	200	80	100	125	150	175	200
AA/AN/AAC/ANC/AFA	1/5	0.10	0.11	0.13	0.14	0.16	0.17	0.08	0.09	0.10	0.11	0.12	0.13	0.05	0.06	0.06	0.07	0.08	0.08
AA/AN/AAC/ANC/AFA	1/4	0.17	0.20	0.22	0.25	0.27	0.29	0.14	0.16	0.17	0.19	0.21	0.22	0.09	0.10	0.11	0.12	0.13	0.14
AA/AN/AAC/ANC/AFA	1/2	0.30	0.35	0.39	0.44	0.48	0.52	0.25	0.27	0.31	0.34	0.36	0.39	0.16	0.17	0.20	0.21	0.23	0.25
AA/AN/AAC/ANC/AFA	1	0.49	0.56	0.63	0.70	0.77	0.83	0.39	0.44	0.49	0.54	0.58	0.62	0.25	0.28	0.31	0.34	0.37	0.40
AA/AN/AAC/ANC/AFA	1-1/2	0.69	0.80	0.90	1.00	1.10	1.19	0.56	0.63	0.70	0.77	0.83	0.89	0.36	0.40	0.45	0.49	0.53	0.57
AA/AN/AAC/ANC/AFA	2	1.02	1.18	1.32	1.48	1.62	1.75	0.83	0.93	1.04	1.13	1.23	1.31	0.53	0.59	0.66	0.72	0.78	0.83
AA/AN/AAC/ANC/AFA	2-3/4	1.44	1.66	1.86	2.07	2.27	2.45	1.16	1.30	1.45	1.59	1.72	1.84	0.74	0.83	0.93	1.01	1.10	1.17
AA/AN/AAC/ANC/AFA	3-1/2	1.76	2.03	2.27	2.54	2.78	3.01	1.42	1.59	1.78	1.95	2.11	2.25	0.91	1.01	1.13	1.24	1.34	1.43
AA/AN/AAC/ANC/AFA	4	2.09	2.41	2.70	3.02	3.30	3.57	1.69	1.89	2.11	2.32	2.50	2.67	1.08	1.20	1.35	1.47	1.59	1.70
AA/AN/AAC/ANC/AFA	5-1/2	2.86	3.30	3.69	4.13	4.52	4.88	2.31	2.59	2.89	3.17	3.42	3.66	1.47	1.65	1.84	2.02	2.18	2.33

Refrigerant liquid temperature correction factors

	Refrigerant liquid temperature °f															
	0	10	20	30	40	50	60	70	80	90	100	110	120	130	140	
R-452A	1.99	1.89	1.80	1.70	1.60	1.50	1.41	1.31	1.21	1.10	1.00	0.89	0.79	0.68	0.56	

NOTE: These factors include corrections for liquid refrigerant density and net refrigeration effect, and are based on an average evaporator temperature of 0°F with a maximum 7°F Change in Superheat. However, they may be used for any evaporator temperature from -40°F to +40°F since the variation in the actual factors across this range is insignificant.

R-502 conventional ported valves (tons) A Series / AFA Series / T Series

Valve type	Nom. rating	Evaporator temperature																	
		50°F						40°F						20°F					
		Pressure drop across valve (psi)						Pressure drop across valve (psi)						Pressure drop across valve (psi)					
		60	80	100	125	150	175	60	80	100	125	150	175	60	80	100	125	150	175
AA/AN/AAC/ANC/AFA	1/8	0.17	0.20	0.22	0.25	0.27	0.29	0.17	0.20	0.22	0.25	0.27	0.29	0.16	0.18	0.21	0.23	0.25	0.27
AA/AN/AAC/ANC/AFA	1/4	0.30	0.35	0.39	0.43	0.47	0.51	0.29	0.33	0.37	0.42	0.46	0.50	0.28	0.32	0.36	0.40	0.44	0.48
AA/AN/AAC/ANC/AFA	1/2	0.48	0.55	0.62	0.69	0.76	0.82	0.47	0.54	0.61	0.68	0.74	0.80	0.45	0.52	0.58	0.65	0.71	0.77
AA/AN/AAC/ANC/AFA	1	0.68	0.79	0.88	0.98	1.08	1.16	0.67	0.77	0.86	0.97	1.06	1.14	0.64	0.74	0.83	0.92	1.01	1.09
AA/AN/AAC/ANC/AFA	1-1/2	1.41	1.63	1.82	2.04	2.23	2.41	1.38	1.59	1.78	1.99	2.18	2.36	1.32	1.52	1.70	1.91	2.09	2.25
AA/AN/AAC/ANC/AFA	2	1.73	2.00	2.23	2.50	2.74	2.95	1.69	1.95	2.18	2.44	2.67	2.89	1.62	1.87	2.09	2.34	2.56	2.77
AA/AN/AAC/ANC/AFA	2-1/2	2.05	2.37	2.65	2.96	3.24	3.50	2.01	2.32	2.59	2.90	3.18	3.43	1.92	2.22	2.48	2.77	3.04	3.28
AA/AN/AAC/ANC/AFA	3	2.81	3.24	3.63	4.06	4.44	4.80	2.75	3.18	3.55	3.97	4.35	4.70	2.62	3.03	3.38	3.78	4.14	4.47
TCLE	1/4	0.26	0.30	0.34	0.38	0.41	0.44	0.25	0.29	0.32	0.36	0.40	0.43	0.24	0.28	0.31	0.35	0.38	0.41
TCLE	1/2	0.48	0.55	0.62	0.69	0.76	0.82	0.47	0.54	0.61	0.68	0.74	0.80	0.45	0.52	0.58	0.65	0.71	0.77
TCLE	1	0.97	1.12	1.25	1.40	1.53	1.66	0.95	1.10	1.23	1.37	1.50	1.62	0.91	1.05	1.17	1.31	1.44	1.55
TCLE	2	1.80	2.08	2.32	2.60	2.85	3.07	1.76	2.03	2.27	2.54	2.78	3.01	1.68	1.94	2.17	2.42	2.66	2.87
TCLE	3	2.62	3.03	3.38	3.78	4.14	4.47	2.56	2.96	3.30	3.70	4.05	4.37	2.44	2.82	3.15	3.52	3.86	4.17
TCLE	4-1/2	3.80	4.39	4.91	5.48	6.01	6.49	3.72	4.30	4.80	5.37	5.88	6.35	3.55	4.10	4.58	5.12	5.61	6.06
TCLE	7	5.23	6.04	6.75	7.55	8.27	8.93	5.12	5.91	6.61	7.39	8.10	8.74	4.89	5.65	6.31	7.06	7.73	8.35
TCLE	8	6.31	7.29	8.15	9.11	9.98	10.78	6.18	7.14	7.98	8.92	9.77	10.55	5.90	6.81	7.62	8.52	9.33	10.08
TJL	7	5.59	6.45	7.22	8.07	8.84	9.55	5.47	6.32	7.06	7.90	8.65	9.34	5.22	6.03	6.74	7.53	8.25	8.91
TJL	9	7.13	8.23	9.20	10.29	11.27	12.18	6.98	8.06	9.01	10.07	11.04	11.92	6.66	7.69	8.60	9.61	10.53	11.37

NOTE: Standard capacity is rated at 100°F liquid inlet and 40°F evaporator temperature; with 100 PSI pressure drop across the TXV per ARI 750-2001.

Valve type	Nom. rating	Evaporator temperature																	
		0°F						-20°F						-40°F					
		Pressure drop across valve (psi)						Pressure drop across valve (psi)						Pressure drop across valve (psi)					
		60	80	100	125	150	175	80	100	125	150	175	200	80	100	125	150	175	200
AA/AN/AAC/ANC/AFA	1/8	0.15	0.17	0.19	0.22	0.24	0.26	0.11	0.12	0.14	0.15	0.16	0.17	0.07	0.08	0.09	0.10	0.10	0.11
AA/AN/AAC/ANC/AFA	1/4	0.26	0.30	0.34	0.38	0.41	0.44	0.20	0.22	0.25	0.27	0.30	0.32	0.13	0.15	0.16	0.18	0.19	0.21
AA/AN/AAC/ANC/AFA	1/2	0.41	0.47	0.53	0.59	0.65	0.70	0.32	0.36	0.40	0.44	0.47	0.51	0.21	0.23	0.26	0.29	0.31	0.33
AA/AN/AAC/ANC/AFA	1	0.59	0.68	0.76	0.85	0.93	1.01	0.46	0.51	0.58	0.63	0.68	0.73	0.29	0.32	0.36	0.40	0.43	0.46
AA/AN/AAC/ANC/AFA	1-1/2	1.21	1.40	1.56	1.75	1.91	2.07	0.96	1.07	1.20	1.31	1.42	1.52	0.61	0.68	0.76	0.84	0.90	0.96
AA/AN/AAC/ANC/AFA	2	1.49	1.72	1.92	2.15	2.36	2.54	1.17	1.31	1.46	1.60	1.73	1.85	0.75	0.84	0.94	1.03	1.11	1.19
AA/AN/AAC/ANC/AFA	2-1/2	1.76	2.03	2.27	2.54	2.78	3.01	1.39	1.55	1.74	1.90	2.06	2.20	0.89	1.00	1.11	1.22	1.32	1.41
AA/AN/AAC/ANC/AFA	3	2.41	2.78	3.11	3.48	3.81	4.12	1.90	2.12	2.38	2.60	2.81	3.00	1.21	1.35	1.51	1.66	1.79	1.91
TCLE	1/4	0.22	0.25	0.28	0.32	0.35	0.38	0.17	0.19	0.21	0.23	0.25	0.27	0.11	0.12	0.14	0.15	0.16	0.17
TCLE	1/2	0.41	0.47	0.53	0.59	0.65	0.70	0.33	0.37	0.41	0.45	0.49	0.52	0.21	0.23	0.26	0.29	0.31	0.33
TCLE	1	0.84	0.97	1.08	1.21	1.33	1.43	0.66	0.74	0.83	0.90	0.98	1.04	0.42	0.47	0.53	0.58	0.62	0.66
TCLE	2	1.54	1.78	1.99	2.22	2.43	2.63	1.22	1.36	1.53	1.67	1.80	1.93	0.78	0.87	0.98	1.07	1.15	1.23
TCLE	3	2.25	2.60	2.90	3.25	3.56	3.84	1.78	1.99	2.23	2.44	2.63	2.81	1.13	1.26	1.41	1.55	1.67	1.79
TCLE	4-1/2	3.26	3.76	4.21	4.71	5.15	5.57	2.58	2.88	3.23	3.53	3.82	4.08	1.64	1.83	2.05	2.25	2.43	2.59
TCLE	7	4.50	5.20	5.81	6.50	7.12	7.69	3.55	3.97	4.44	4.86	5.25	5.61	2.26	2.53	2.83	3.09	3.34	3.57
TCLE	8	5.42	6.26	7.00	7.82	8.57	9.26	4.28	4.79	5.35	5.86	6.33	6.77	2.73	3.05	3.41	3.74	4.04	4.32
TJL	7	4.81	5.55	6.21	6.94	7.61	8.21	3.80	4.25	4.75	5.20	5.62	6.01	2.42	2.71	3.03	3.31	3.58	3.83
TJL	9	6.13	7.08	7.91	8.85	9.69	10.47	4.84	5.41	6.05	6.63	7.16	7.65	3.08	3.44	3.85	4.22	4.56	4.87

Refrigerant liquid temperature correction factors

	Refrigerant liquid temperature °f															
	0	10	20	30	40	50	60	70	80	90	100	110	120	130	140	
R-502	1.83	1.75	1.67	1.59	1.50	1.42	1.34	1.26	1.17	1.09	1.00	0.91	0.82	0.73	0.64	

NOTE: These factors include corrections for liquid refrigerant density and net refrigeration effect, and are based on an average evaporator temperature of 0°F with a maximum 7°F Change in Superheat. However, they may be used for any evaporator temperature from -40°F to +40°F since the variation in the actual factors across this range is insignificant.

R-1234yf conventional ported valves (tons) A Series

Valve type	Nom. rating	Evaporator temperature																	
		50°F						40°F						20°F					
		Pressure drop across valve (psi)						Pressure drop across valve (psi)						Pressure drop across valve (psi)					
		60	80	100	125	150	175	60	80	100	125	150	175	60	80	100	125	150	175
AA/AN/AFA	1/14	0.06	0.07	0.07	0.08	0.09	0.10	0.06	0.06	0.07	0.08	0.09	0.09	0.04	0.05	0.05	0.06	0.07	0.07
AA/AN/AAC/ANC	1/8	0.10	0.11	0.13	0.14	0.16	0.17	0.10	0.11	0.12	0.14	0.15	0.16	0.07	0.09	0.10	0.11	0.12	0.13
AA/AN/AAC/ANC/AFA	1/4	0.17	0.20	0.22	0.25	0.28	0.30	0.17	0.20	0.22	0.24	0.27	0.29	0.13	0.15	0.17	0.19	0.21	0.22
AA/AN/AAC/ANC/AFA	3/8	0.28	0.32	0.36	0.40	0.44	0.48	0.27	0.31	0.35	0.39	0.43	0.46	0.21	0.24	0.27	0.30	0.33	0.36
AA/AN/AAC/ANC/AFA	1/2	0.40	0.46	0.52	0.58	0.63	0.68	0.39	0.45	0.50	0.56	0.61	0.66	0.30	0.34	0.38	0.43	0.47	0.51
AA/AN/AAC/ANC/AFA	3/4	0.59	0.68	0.76	0.85	0.93	1.01	0.57	0.66	0.74	0.82	0.90	0.98	0.44	0.51	0.57	0.63	0.69	0.75
AA/AN/AAC/ANC/AFA	1	0.83	0.95	1.07	1.19	1.31	1.41	0.80	0.93	1.03	1.16	1.27	1.37	0.62	0.71	0.80	0.89	0.97	1.05
AA/AN/AAC/ANC/AFA	3 1/4	1.01	1.17	1.31	1.46	1.60	1.73	0.98	1.13	1.27	1.42	1.55	1.68	0.75	0.87	0.97	1.09	1.19	1.29
AA/AN/AAC/ANC/AFA	1 1/2	1.20	1.39	1.55	1.73	1.90	2.05	1.17	1.35	1.50	1.68	1.84	1.99	0.90	1.03	1.16	1.29	1.42	1.53
AA/AN/AAC/ANC/AFA	2	1.64	1.90	2.12	2.37	2.60	2.81	1.59	1.84	2.06	2.30	2.52	2.72	1.23	1.41	1.58	1.77	1.94	2.09

Valve type	Nom. rating	Evaporator temperature																	
		0°F						-20°F						-40°F					
		Pressure drop across valve (psi)						Pressure drop across valve (psi)						Pressure drop across valve (psi)					
		60	80	100	125	150	175	80	100	125	150	175	200	80	100	125	150	175	200
AA/AN/AFA	1/14	0.03	0.03	0.04	0.04	0.05	0.05	0.02	0.02	0.03	0.03	0.03	0.03	0.01	0.02	0.02	0.02	0.02	0.02
AA/AN/AAC/ANC	1/8	0.05	0.06	0.06	0.07	0.08	0.09	0.04	0.04	0.05	0.05	0.06	0.06	0.02	0.03	0.03	0.03	0.03	0.04
AA/AN/AAC/ANC/AFA	1/4	0.09	0.10	0.11	0.13	0.14	0.15	0.07	0.07	0.08	0.09	0.10	0.10	0.04	0.05	0.05	0.06	0.06	0.06
AA/AN/AAC/ANC/AFA	3/8	0.14	0.16	0.18	0.20	0.22	0.24	0.11	0.12	0.13	0.15	0.16	0.17	0.07	0.07	0.08	0.09	0.10	0.10
AA/AN/AAC/ANC/AFA	1/2	0.20	0.23	0.26	0.29	0.32	0.35	0.15	0.17	0.19	0.21	0.22	0.24	0.09	0.11	0.12	0.13	0.14	0.15
AA/AN/AAC/ANC/AFA	3/4	0.30	0.34	0.38	0.43	0.47	0.51	0.22	0.25	0.28	0.31	0.33	0.35	0.14	0.15	0.17	0.19	0.20	0.22
AA/AN/AAC/ANC/AFA	1	0.42	0.48	0.54	0.60	0.66	0.71	0.31	0.35	0.39	0.43	0.46	0.50	0.19	0.22	0.24	0.27	0.29	0.31
AA/AN/AAC/ANC/AFA	3-1/4	0.51	0.59	0.66	0.74	0.81	0.88	0.39	0.43	0.48	0.53	0.57	0.61	0.24	0.27	0.30	0.33	0.35	0.38
AA/AN/AAC/ANC/AFA	1-1/2	0.61	0.70	0.79	0.88	0.96	1.04	0.46	0.51	0.57	0.63	0.68	0.72	0.28	0.32	0.35	0.39	0.42	0.45
AA/AN/AAC/ANC/AFA	2	0.83	0.96	1.07	1.20	1.32	1.42	0.62	0.70	0.78	0.86	0.92	0.99	0.39	0.43	0.48	0.53	0.57	0.61

Refrigerant liquid temperature correction factors

	Refrigerant liquid temperature °f															
	0	10	20	30	40	50	60	70	80	90	100	110	120	130	140	
R-1234yf	1.89	1.80	1.72	1.63	1.54	1.45	1.36	1.27	1.18	1.09	1.00	0.91	0.82	0.72	0.63	

NOTE: These factors include corrections for liquid refrigerant density and net refrigeration effect, and are based on an average evaporator temperature of 0°F with a maximum 7°F Change in Superheat. However, they may be used for any evaporator temperature from -40°F to +40°F since the variation in the actual factors across this range is insignificant.

# Balanced ported valve capacity tables

R-12 balanced ported valves (tons) B / HF / TRAE / T Series

Valve type	Nom. rating	Evaporator temperature																	
		50°F						40°F						20°F					
		Pressure drop across valve (psi)						Pressure drop across valve (psi)						Pressure drop across valve (psi)					
		60	80	100	125	150	175	60	80	100	125	150	175	60	80	100	125	150	175
BA/BN	1/4	0.30	0.35	0.39	0.43	0.47	0.51	0.30	0.35	0.39	0.43	0.47	0.51	0.28	0.32	0.36	0.40	0.44	0.48
BA/BN	1/2	0.57	0.66	0.74	0.82	0.90	0.97	0.56	0.65	0.72	0.81	0.89	0.96	0.54	0.62	0.70	0.78	0.85	0.92
BA/BN	1	0.90	1.04	1.16	1.30	1.42	1.54	0.88	1.02	1.14	1.27	1.39	1.50	0.84	0.97	1.08	1.21	1.33	1.43
BA/BN	1-1/4	1.20	1.39	1.55	1.73	1.90	2.05	1.17	1.35	1.51	1.69	1.85	2.00	1.13	1.30	1.46	1.63	1.79	1.93
BA/BN	1-1/2	1.51	1.74	1.95	2.18	2.39	2.58	1.48	1.71	1.91	2.14	2.34	2.53	1.42	1.64	1.83	2.05	2.25	2.43
BA/BN	2	1.83	2.11	2.36	2.64	2.89	3.13	1.80	2.08	2.32	2.60	2.85	3.07	1.72	1.99	2.22	2.48	2.72	2.94
BA/BN	2-1/2	2.37	2.74	3.06	3.42	3.75	4.05	2.33	2.69	3.01	3.36	3.68	3.98	2.23	2.57	2.88	3.22	3.53	3.81
BA/BN	3	3.00	3.46	3.87	4.33	4.74	5.12	2.94	3.39	3.80	4.24	4.65	5.02	2.82	3.26	3.64	4.07	4.46	4.82
BA/BN	3-1/2	3.73	4.31	4.82	5.38	5.90	6.37	3.66	4.23	4.73	5.28	5.79	6.25	3.51	4.05	4.53	5.07	5.55	5.99
HF	1/8	0.17	0.20	0.22	0.25	0.27	0.29	0.17	0.20	0.22	0.25	0.27	0.29	0.16	0.18	0.21	0.23	0.25	0.27
HF	1/4	0.32	0.37	0.41	0.46	0.51	0.55	0.31	0.36	0.40	0.45	0.49	0.53	0.30	0.35	0.39	0.43	0.47	0.51
HF	1/2	0.57	0.66	0.74	0.82	0.90	0.97	0.56	0.65	0.72	0.81	0.89	0.96	0.54	0.62	0.70	0.78	0.85	0.92
HF	1	0.88	1.02	1.14	1.27	1.39	1.50	0.86	0.99	1.11	1.24	1.36	1.47	0.82	0.95	1.06	1.18	1.30	1.40
HF	1-1/4	1.18	1.36	1.52	1.70	1.87	2.02	1.16	1.34	1.50	1.67	1.83	1.98	1.11	1.28	1.43	1.60	1.76	1.90
HF	1-1/2	1.51	1.74	1.95	2.18	2.39	2.58	1.48	1.71	1.91	2.14	2.34	2.53	1.42	1.64	1.83	2.05	2.25	2.43
HF	2	2.00	2.31	2.58	2.89	3.16	3.42	1.96	2.26	2.53	2.83	3.10	3.35	1.88	2.17	2.43	2.71	2.97	3.21
HF	3-1/2	3.55	4.10	4.58	5.12	5.61	6.06	3.48	4.02	4.49	5.02	5.50	5.94	3.34	3.86	4.31	4.82	5.28	5.70
HF	5	4.94	5.70	6.38	7.13	7.81	8.44	4.85	5.60	6.26	7.00	7.67	8.28	4.65	5.37	6.00	6.71	7.35	7.94
HF	6	6.26	7.23	8.08	9.04	9.90	10.69	6.13	7.08	7.91	8.85	9.69	10.47	5.88	6.79	7.59	8.49	9.30	10.04
HF	9	9.28	10.72	11.98	13.39	14.67	15.85	9.10	10.51	11.75	13.13	14.39	15.54	8.73	10.08	11.27	12.60	13.80	14.91
HF	12	12.22	14.11	15.78	17.64	19.32	20.87	11.98	13.83	15.47	17.29	18.94	20.46	11.49	13.27	14.83	16.58	18.17	19.62
TRAE+	7-1/2	7.14	8.24	9.22	10.31	11.29	12.19	7.00	8.08	9.04	10.10	11.07	11.95	6.71	7.75	8.66	9.69	10.61	11.46
TRAE+	10	10.41	12.02	13.44	15.03	16.46	17.78	10.20	11.78	13.17	14.72	16.13	17.42	9.78	11.29	12.63	14.12	15.46	16.70
TRAE+	12	11.62	13.42	15.00	16.77	18.37	19.84	11.39	13.15	14.70	16.44	18.01	19.45	10.92	12.61	14.10	15.76	17.27	18.65
TRAE+	18	17.61	20.33	22.73	25.42	27.84	30.07	17.26	19.93	22.28	24.91	27.29	29.48	16.55	19.11	21.37	23.89	26.17	28.26
TRAE+	25	24.20	27.94	31.24	34.93	38.26	41.33	23.73	27.40	30.64	34.25	37.52	40.53	22.75	26.27	29.37	32.84	35.97	38.85
TRAE	30	32.67	37.72	42.18	47.16	51.66	55.79	32.03	36.99	41.35	46.23	50.64	54.70	30.72	35.47	39.66	44.34	48.57	52.46
TRAE	35	35.64	41.15	46.01	51.44	56.35	60.87	34.94	40.35	45.11	50.43	55.24	59.67	33.51	38.69	43.26	48.37	52.98	57.23
TRAE	40	42.41	48.97	54.75	61.21	67.06	72.43	41.58	48.01	53.68	60.02	65.74	71.01	39.88	46.05	51.48	57.56	63.06	68.11
TJR	8	8.89	10.27	11.48	12.83	14.06	15.18	8.72	10.07	11.26	12.59	13.79	14.89	8.36	9.65	10.79	12.07	13.22	14.28
TJR	11	10.65	12.30	13.75	15.37	16.84	18.19	10.44	12.06	13.48	15.07	16.51	17.83	10.01	11.56	12.92	14.45	15.83	17.10
TER	13	13.31	15.37	17.18	19.21	21.04	22.73	13.05	15.07	16.85	18.84	20.63	22.29	12.51	14.45	16.15	18.06	19.78	21.36
TER	15	15.73	18.16	20.31	22.70	24.87	26.86	15.42	17.81	19.91	22.26	24.38	26.33	14.79	17.08	19.09	21.35	23.39	25.26
TER	20	21.18	24.46	27.34	30.57	33.49	36.17	20.76	23.97	26.80	29.96	32.82	35.45	19.91	22.99	25.70	28.74	31.48	34.00
TER	25	27.23	31.44	35.15	39.30	43.05	46.50	26.69	30.82	34.46	38.52	42.20	45.58	25.60	29.56	33.05	36.95	40.48	43.72
TIR	35	31.29	36.13	40.40	45.16	49.47	53.44	23.63	27.29	30.51	34.11	37.36	40.36	31.29	36.13	40.40	45.16	49.47	53.44
THR	45	42.35	48.90	54.67	61.13	66.96	72.33	41.52	47.94	53.60	59.93	65.65	70.91	39.82	45.98	51.41	57.48	62.96	68.01
THR	55	51.43	59.39	66.40	74.23	81.32	87.83	50.42	58.22	65.09	72.78	79.72	86.11	48.35	55.83	62.42	69.79	76.45	82.57
TMR	55	60.50	69.86	78.11	87.32	95.66	103.32	59.32	68.50	76.58	85.62	93.79	101.31	56.89	65.69	73.44	82.11	89.95	97.16

NOTE: Standard capacity is rated at 100°F liquid inlet and 40°F evaporator temperature; with 60 PSI pressure drop across the TXV per ARI 750-2001.



Capacity tables (kW)

R-12 balanced ported valves (tons) B / HF / TRAE / T Series (cont'd)

Valve type	Nom. rating	Evaporator temperature																	
		0°F						-20°F						-40°F					
		Pressure drop across valve (psi)						Pressure drop across valve (psi)						Pressure drop across valve (psi)					
		60	80	100	125	150	175	60	80	100	125	150	175	60	80	100	125	150	175
BA/BN	1/4	0.25	0.29	0.32	0.36	0.40	0.43	0.20	0.22	0.25	0.27	0.30	0.32	0.13	0.15	0.16	0.18	0.19	0.21
BA/BN	1/2	0.48	0.55	0.62	0.69	0.76	0.82	0.38	0.42	0.48	0.52	0.56	0.60	0.24	0.27	0.30	0.33	0.35	0.38
BA/BN	1	0.75	0.87	0.97	1.08	1.19	1.28	0.58	0.65	0.73	0.79	0.86	0.92	0.38	0.42	0.48	0.52	0.56	0.60
BA/BN	1-1/4	1.00	1.15	1.29	1.44	1.58	1.71	0.78	0.87	0.98	1.07	1.15	1.23	0.51	0.57	0.64	0.70	0.75	0.81
BA/BN	1-1/2	1.26	1.45	1.63	1.82	1.99	2.15	0.99	1.11	1.24	1.36	1.46	1.57	0.64	0.72	0.80	0.88	0.95	1.01
BA/BN	2	1.53	1.77	1.98	2.21	2.42	2.61	1.20	1.34	1.50	1.64	1.77	1.90	0.78	0.87	0.98	1.07	1.15	1.23
BA/BN	2-1/2	1.98	2.29	2.56	2.86	3.13	3.38	1.55	1.73	1.94	2.12	2.29	2.45	1.01	1.13	1.26	1.38	1.49	1.60
BA/BN	3	2.50	2.89	3.23	3.61	3.95	4.27	1.96	2.19	2.45	2.68	2.90	3.10	1.27	1.42	1.59	1.74	1.88	2.01
BA/BN	3-1/2	3.11	3.59	4.01	4.49	4.92	5.31	2.44	2.73	3.05	3.34	3.61	3.86	1.58	1.77	1.98	2.16	2.34	2.50
HF	1/8	0.14	0.16	0.18	0.20	0.22	0.24	0.11	0.12	0.14	0.15	0.16	0.17	0.07	0.08	0.09	0.10	0.10	0.11
HF	1/4	0.27	0.31	0.35	0.39	0.43	0.46	0.21	0.23	0.26	0.29	0.31	0.33	0.14	0.16	0.18	0.19	0.21	0.22
HF	1/2	0.48	0.55	0.62	0.69	0.76	0.82	0.38	0.42	0.48	0.52	0.56	0.60	0.24	0.27	0.30	0.33	0.35	0.38
HF	1	0.73	0.84	0.94	1.05	1.15	1.25	0.57	0.64	0.71	0.78	0.84	0.90	0.37	0.41	0.46	0.51	0.55	0.59
HF	1-1/4	0.98	1.13	1.27	1.41	1.55	1.67	0.77	0.86	0.96	1.05	1.14	1.22	0.50	0.56	0.63	0.68	0.74	0.79
HF	1-1/2	1.26	1.45	1.63	1.82	1.99	2.15	0.99	1.11	1.24	1.36	1.46	1.57	0.64	0.72	0.80	0.88	0.95	1.01
HF	2	1.66	1.92	2.14	2.40	2.62	2.83	1.30	1.45	1.63	1.78	1.92	2.06	0.85	0.95	1.06	1.16	1.26	1.34
HF	3-1/2	2.96	3.42	3.82	4.27	4.68	5.06	2.32	2.59	2.90	3.18	3.43	3.67	1.51	1.69	1.89	2.07	2.23	2.39
HF	5	4.12	4.76	5.32	5.95	6.51	7.04	3.23	3.61	4.04	4.42	4.78	5.11	2.10	2.35	2.63	2.88	3.11	3.32
HF	6	5.21	6.02	6.73	7.52	8.24	8.90	4.08	4.56	5.10	5.59	6.03	6.45	2.66	2.97	3.33	3.64	3.93	4.21
HF	9	7.73	8.93	9.98	11.16	12.22	13.20	6.06	6.78	7.58	8.30	8.96	9.58	3.94	4.41	4.93	5.40	5.83	6.23
HF	12	10.17	11.74	13.13	14.68	16.08	17.37	7.97	8.91	9.96	10.91	11.79	12.60	5.18	5.79	6.48	7.09	7.66	8.19
TRAE+	7-1/2	5.95	6.87	7.68	8.59	9.41	10.16	4.66	5.21	5.83	6.38	6.89	7.37	3.03	3.39	3.79	4.15	4.48	4.79
TRAE+	10	8.67	10.01	11.19	12.51	13.71	14.81	6.79	7.59	8.49	9.30	10.04	10.74	4.42	4.94	5.53	6.05	6.54	6.99
TRAE+	12	9.67	11.17	12.48	13.96	15.29	16.51	7.58	8.47	9.48	10.38	11.21	11.99	4.93	5.51	6.16	6.75	7.29	7.80
TRAE+	18	14.66	16.93	18.93	21.16	23.18	25.04	11.49	12.85	14.36	15.73	16.99	18.17	7.47	8.35	9.34	10.23	11.05	11.81
TRAE+	25	20.15	23.27	26.01	29.08	31.86	34.41	15.80	17.66	19.75	21.64	23.37	24.98	10.27	11.48	12.84	14.06	15.19	16.24
TRAE	30	27.21	31.42	35.13	39.27	43.02	46.47	21.33	23.85	26.66	29.21	31.55	33.73	13.87	15.51	17.34	18.99	20.51	21.93
TRAE	35	29.68	34.27	38.32	42.84	46.93	50.69	23.26	26.01	29.08	31.85	34.40	36.78	15.13	16.92	18.91	20.72	22.38	23.92
TRAE	40	35.32	40.78	45.60	50.98	55.85	60.32	27.68	30.95	34.60	37.90	40.94	43.77	18.00	20.12	22.50	24.65	26.62	28.46
TJR	8	7.41	8.56	9.57	10.70	11.72	12.65	5.81	6.50	7.26	7.96	8.59	9.19	3.77	4.21	4.71	5.16	5.58	5.96
TJR	11	8.87	10.24	11.45	12.80	14.02	15.15	6.95	7.77	8.69	9.52	10.28	10.99	4.52	5.05	5.65	6.19	6.69	7.15
TER	13	11.08	12.79	14.30	15.99	17.52	18.92	8.69	9.72	10.86	11.90	12.85	13.74	5.65	6.32	7.06	7.74	8.36	8.93
TER	15	13.10	15.13	16.91	18.91	20.71	22.37	10.27	11.48	12.84	14.06	15.19	16.24	6.68	7.47	8.35	9.15	9.88	10.56
TER	20	17.64	20.37	22.77	25.46	27.89	30.13	13.82	15.45	17.28	18.92	20.44	21.85	8.99	10.05	11.24	12.31	13.30	14.21
TER	25	22.67	26.18	29.27	32.72	35.84	38.72	17.77	19.87	22.21	24.33	26.28	28.10	11.56	12.92	14.45	15.83	17.10	18.28
TIR	35	27.71	32.00	35.77	40.00	43.81	47.32	21.72	24.28	27.15	29.74	32.12	34.34	14.12	15.79	17.65	19.33	20.88	22.33
THR	45	35.27	40.73	45.53	50.91	55.77	60.23	27.64	30.90	34.55	37.85	40.88	43.70	17.98	20.10	22.48	24.62	26.59	28.43
THR	55	42.83	49.46	55.29	61.82	67.72	73.15	33.57	37.53	41.96	45.97	49.65	53.08	21.83	24.41	27.29	29.89	32.29	34.52
TMR	55	50.39	58.19	65.05	72.73	79.67	86.06	39.49	44.15	49.36	54.07	58.41	62.44	25.68	28.71	32.10	35.16	37.98	40.60

NOTE: Standard capacity is rated at 100°F liquid inlet and 40°F evaporator temperature; with 60 PSI pressure drop across the TXV per ARI 750-2001.

Refrigerant liquid temperature correction factors

	Refrigerant liquid temperature °F															
	0	10	20	30	40	50	60	70	80	90	100	110	120	130	140	
R-12	1.60	1.54	1.48	1.42	1.36	1.30	1.24	1.18	1.12	1.06	1.00	0.94	0.88	0.82	0.75	

NOTE: These factors include corrections for liquid refrigerant density and net refrigeration effect, and are based on an average evaporator temperature of 0°F with a maximum 7°F Change in Superheat. However, they may be used for any evaporator temperature from -40°F to +40°F since the variation in the actual factors across this range is insignificant.

R-22 balanced ported valves (tons) NXT-R / B / HF / TFE / TRAE / T Series

Valve type	Nom. rating	Evaporator temperature																	
		50°F						40°F						20°F					
		Pressure drop across valve (psi)						Pressure drop across valve (psi)						Pressure drop across valve (psi)					
		60	80	100	125	150	175	60	80	100	125	150	175	60	80	100	125	150	175
NXT-R	1/10	0.05	0.05	0.06	0.07	0.07	0.08	0.05	0.05	0.06	0.07	0.07	0.08	0.05	0.05	0.06	0.07	0.07	0.08
NXT-R	1/5	0.12	0.14	0.15	0.17	0.19	0.2	0.12	0.13	0.15	0.17	0.18	0.2	0.11	0.13	0.15	0.16	0.18	0.19
NXT-R	1/4	0.31	0.35	0.39	0.44	0.48	0.52	0.3	0.35	0.39	0.44	0.48	0.52	0.29	0.34	0.38	0.42	0.47	0.5
NXT-R	1/2	0.51	0.59	0.66	0.74	0.81	0.87	0.5	0.58	0.65	0.73	0.8	0.86	0.49	0.57	0.63	0.71	0.78	0.84
NXT-R	1	0.68	0.79	0.88	0.98	1.08	1.16	0.67	0.78	0.87	0.97	1.07	1.15	0.66	0.76	0.85	0.95	1.04	1.12
NXT-R	1 1/2	1.22	1.41	1.58	1.76	1.93	2.09	1.21	1.4	1.56	1.74	1.91	2.06	1.18	1.36	1.52	1.7	1.86	2.01
NXT-R	2	1.63	1.88	2.1	2.35	2.58	2.78	1.61	1.86	2.08	2.33	2.55	2.75	1.57	1.81	2.03	2.27	2.48	2.68
NXT-R	2 1/2	2.17	2.51	2.8	3.13	3.43	3.71	2.15	2.48	2.77	3.1	3.39	3.66	2.09	2.41	2.7	3.02	3.3	3.57
NXT-R	3	2.43	2.81	3.14	3.51	3.84	4.15	2.4	2.77	3.1	3.47	3.8	4.1	2.34	2.7	3.02	3.38	3.7	3.99
NXT-R	4	3.17	3.66	4.09	4.57	5.01	5.41	3.13	3.61	4.04	4.52	4.95	5.34	3.05	3.52	3.94	4.4	4.82	5.21
NXT-R	5	3.96	4.57	5.11	5.71	6.26	6.76	3.91	4.52	5.05	5.65	6.18	6.68	3.81	4.4	4.92	5.5	6.02	6.51
NXT-R	6	4.28	4.94	5.52	6.18	6.77	7.31	4.23	4.88	5.46	6.1	6.69	7.22	4.12	4.76	5.32	5.95	6.51	7.04
NXT-R	8	6.14	7.1	7.93	8.87	9.72	10.49	6.07	7.01	7.84	8.76	9.6	10.37	5.92	6.83	7.64	8.54	9.35	10.1
BA/BN	1/2	0.39	0.45	0.5	0.56	0.62	0.67	0.39	0.45	0.5	0.56	0.61	0.66	0.38	0.44	0.49	0.55	0.6	0.65
BA/BN	1	0.75	0.87	0.97	1.08	1.19	1.28	0.74	0.85	0.95	1.06	1.16	1.26	0.72	0.83	0.93	1.04	1.14	1.23
BA/BN	1-1/2	1.16	1.34	1.5	1.67	1.83	1.98	1.15	1.32	1.48	1.65	1.81	1.96	1.12	1.29	1.45	1.62	1.77	1.91
BA/BN	2	1.56	1.8	2.01	2.25	2.47	2.66	1.53	1.77	1.98	2.21	2.42	2.62	1.5	1.73	1.94	2.17	2.37	2.56
BA/BN	2-1/2	1.96	2.26	2.53	2.83	3.1	3.35	1.94	2.24	2.5	2.8	3.06	3.31	1.89	2.18	2.44	2.73	2.99	3.23
BA/BN	3	2.38	2.75	3.07	3.44	3.76	4.06	2.35	2.71	3.03	3.39	3.71	4.01	2.29	2.64	2.96	3.31	3.62	3.91
BA/BN	4	3.08	3.56	3.98	4.45	4.87	5.26	3.04	3.51	3.92	4.38	4.8	5.19	2.97	3.43	3.83	4.29	4.7	5.07
BA/BN	5	3.9	4.5	5.03	5.63	6.17	6.66	3.85	4.45	4.97	5.56	6.09	6.57	3.75	4.33	4.84	5.41	5.93	6.4
BA/BN	6	4.85	5.6	6.26	7	7.67	8.28	4.78	5.52	6.17	6.9	7.56	8.16	4.67	5.39	6.03	6.74	7.38	7.98
HF	1/4	0.22	0.25	0.28	0.32	0.35	0.38	0.22	0.25	0.28	0.31	0.34	0.37	0.21	0.24	0.27	0.3	0.33	0.36
HF	1/2	0.42	0.48	0.54	0.61	0.66	0.72	0.41	0.47	0.53	0.59	0.65	0.7	0.4	0.46	0.52	0.58	0.63	0.68
HF	1	0.75	0.87	0.97	1.08	1.19	1.28	0.74	0.85	0.95	1.06	1.16	1.26	0.72	0.83	0.93	1.04	1.14	1.23
HF	1-1/2	1.14	1.32	1.47	1.65	1.8	1.95	1.12	1.3	1.45	1.62	1.78	1.92	1.1	1.27	1.42	1.59	1.74	1.88
HF	2	1.53	1.77	1.98	2.21	2.42	2.61	1.52	1.75	1.96	2.19	2.4	2.59	1.48	1.71	1.91	2.14	2.34	2.53
HF	2-1/2	1.96	2.26	2.53	2.83	3.1	3.35	1.94	2.25	2.51	2.81	3.07	3.32	1.89	2.18	2.44	2.73	2.99	3.23
HF	3	2.59	2.99	3.34	3.74	4.1	4.42	2.56	2.96	3.31	3.7	4.05	4.38	2.5	2.89	3.23	3.61	3.95	4.27
HF	5-1/2	4.61	5.32	5.95	6.65	7.29	7.87	4.56	5.27	5.89	6.59	7.21	7.79	4.44	5.13	5.73	6.41	7.02	7.58
HF	8	6.42	7.41	8.29	9.27	10.15	10.96	6.34	7.33	8.19	9.16	10.03	10.83	6.18	7.14	7.98	8.92	9.77	10.55
HF	10	8.13	9.39	10.5	11.73	12.85	13.88	8.06	9.3	10.4	11.63	12.74	13.76	7.83	9.04	10.11	11.3	12.38	13.37
HF	15	12.05	13.91	15.56	17.39	19.05	20.58	11.91	13.77	15.4	17.22	18.86	20.37	11.61	13.41	14.99	16.76	18.36	19.83
HF	20	15.87	18.33	20.49	22.91	25.09	27.1	15.68	18.07	20.2	22.58	24.74	26.72	15.28	17.64	19.73	22.05	24.16	26.1
TFE	8	6.3	7.27	8.13	9.09	9.96	10.76	6.23	7.19	8.04	8.99	9.85	10.64	6.07	7.01	7.84	8.76	9.6	10.37
TFE	10	8.63	9.97	11.14	12.46	13.65	14.74	8.53	9.85	11.01	12.31	13.48	14.56	8.31	9.6	10.73	11.99	13.14	14.19
TFE	12	10.71	12.37	13.83	15.46	16.93	18.29	10.59	12.23	13.67	15.28	16.74	18.08	10.32	11.92	13.32	14.9	16.32	17.62
TFE	20	16.35	18.88	21.11	23.6	25.85	27.92	16.17	18.67	20.87	23.33	25.56	27.61	15.75	18.19	20.33	22.73	24.9	26.9
TRAE+	10	9.27	10.7	11.97	13.38	14.66	15.83	9.16	10.58	11.83	13.23	14.49	15.65	8.93	10.31	11.53	12.89	14.12	15.25
TRAE+	15	13.52	15.61	17.45	19.51	21.38	23.09	13.36	15.43	17.25	19.29	21.13	22.82	13.02	15.03	16.81	18.79	20.59	22.24
TRAE+	20	15.09	17.42	19.48	21.78	23.86	25.77	14.91	17.22	19.25	21.52	23.58	25.47	14.53	16.78	18.76	20.97	22.97	24.81
TRAE+	30	22.87	26.41	29.53	33.01	36.16	39.06	22.6	26.1	29.18	32.62	35.74	38.6	22.02	25.43	28.43	31.78	34.82	37.61
TRAE+	40	31.43	36.29	40.58	45.37	49.7	53.68	31.07	35.88	40.11	44.84	49.12	53.06	30.27	34.95	39.08	43.69	47.86	51.7
TRAE	50	42.43	48.99	54.78	61.24	67.09	72.46	41.94	48.42	54.14	60.53	66.31	71.62	40.87	47.19	52.76	58.99	64.62	69.8
TRAE	60	46.28	53.44	59.75	66.8	73.18	79.04	45.75	52.82	59.06	66.03	72.33	78.13	44.58	51.48	57.55	64.35	70.49	76.13
TRAE	70	55.09	63.61	71.12	79.52	87.1	94.08	54.45	62.87	70.29	78.59	86.09	92.98	53.06	61.27	68.5	76.59	83.9	90.62
TJR	14	11.55	13.34	14.91	16.67	18.26	19.73	11.42	13.18	14.74	16.48	18.05	19.5	11.13	12.85	14.37	16.06	17.6	19.01
TJR	18	13.83	15.97	17.85	19.96	21.87	23.62	13.67	15.79	17.65	19.73	21.62	23.35	13.32	15.38	17.2	19.23	21.06	22.75
TER	22	17.29	19.96	22.32	24.96	27.34	29.53	17.09	19.73	22.06	24.66	27.02	29.18	16.65	19.23	21.5	24.03	26.33	28.44
TER	26	20.43	23.59	26.38	29.49	32.3	34.89	20.19	23.32	26.07	29.15	31.93	34.49	19.68	22.72	25.41	28.41	31.12	33.61
TER	35	27.5	31.75	35.5	39.69	43.48	46.97	27.18	31.39	35.09	39.23	42.98	46.42	26.49	30.59	34.2	38.24	41.88	45.24
TER	45	35.36	40.83	45.65	51.04	55.91	60.39	34.95	40.36	45.12	50.45	55.26	59.69	34.06	39.33	43.97	49.16	53.85	58.17
TIR	55	43.22	49.91	55.8	62.38	68.34	73.81	42.72	49.33	55.15	61.66	67.54	72.96	41.63	48.07	53.74	60.09	65.82	71.1
THR	75	55.01	63.52	71.02	79.4	86.98	93.95	54.37	62.78	70.19	78.47	85.96	92.85	52.98	61.18	68.4	76.47	83.77	90.48
THR	85	66.79	77.12	86.23	96.4	105.6	114.07	66.02	76.23	85.23	95.29	104.39	112.75	64.33	74.28	83.05	92.85	101.71	109.86
TMR	100	78.58	90.74	101.45	113.42	124.25	134.2	77.67	89.68	100.27	112.11	122.81	132.64	75.69	87.4	97.72	109.25	119.68	129.27

NOTE: Standard capacity is rated at 100°F liquid inlet and 40°F evaporator temperature; with 60 PSI pressure drop across the TXV per ARI 750-2001.

R-22 balanced ported valves (tons) NXT-R / B / HF / TFE / TRAE / T Series (cont.)

Valve type	Nom. rating	Evaporator temperature																	
		0°F						-20°F						-40°F					
		Pressure drop across valve (psi)						Pressure drop across valve (psi)						Pressure drop across valve (psi)					
		60	80	100	125	150	175	80	100	125	150	175	200	80	100	125	150	175	200
NXT-R	1/10	0.04	0.05	0.05	0.06	0.06	0.07	0.03	0.04	0.04	0.04	0.05	0.05	0.02	0.02	0.03	0.03	0.03	0.03
NXT-R	1/5	0.1	0.12	0.13	0.15	0.16	0.17	0.08	0.09	0.1	0.11	0.12	0.13	0.05	0.06	0.07	0.07	0.08	0.09
NXT-R	1/4	0.26	0.31	0.34	0.38	0.42	0.45	0.21	0.24	0.26	0.29	0.31	0.33	0.14	0.16	0.18	0.19	0.21	0.22
NXT-R	1/2	0.44	0.51	0.57	0.64	0.7	0.75	0.35	0.39	0.44	0.48	0.52	0.56	0.23	0.26	0.29	0.32	0.35	0.37
NXT-R	1	0.59	0.68	0.76	0.85	0.93	1.01	0.47	0.53	0.59	0.65	0.7	0.75	0.31	0.35	0.39	0.43	0.46	0.5
NXT-R	1 1/2	1.06	1.22	1.37	1.53	1.67	1.81	0.85	0.95	1.06	1.16	1.25	1.34	0.56	0.63	0.7	0.77	0.83	0.89
NXT-R	2	1.41	1.63	1.82	2.04	2.23	2.41	1.13	1.26	1.41	1.55	1.67	1.79	0.75	0.84	0.94	1.03	1.11	1.19
NXT-R	2 1/2	1.88	2.17	2.43	2.71	2.97	3.21	1.5	1.68	1.88	2.06	2.22	2.38	1	1.12	1.25	1.37	1.48	1.58
NXT-R	3	2.1	2.43	2.72	3.04	3.33	3.59	1.68	1.88	2.1	2.31	2.49	2.66	1.12	1.25	1.4	1.53	1.65	1.77
NXT-R	4	2.74	3.16	3.54	3.96	4.33	4.68	2.19	2.45	2.74	3	3.24	3.47	1.46	1.63	1.82	1.99	2.15	2.3
NXT-R	5	3.43	3.96	4.42	4.95	5.42	5.85	2.74	3.07	3.43	3.76	4.06	4.34	1.82	2.04	2.28	2.49	2.69	2.88
NXT-R	6	3.7	4.28	4.78	5.35	5.86	6.33	2.96	3.31	3.71	4.06	4.39	4.69	1.97	2.2	2.46	2.69	2.91	3.11
NXT-R	8	5.32	6.14	6.87	7.68	8.41	9.08	4.26	4.76	5.32	5.83	6.3	6.73	2.83	3.16	3.53	3.87	4.18	4.47
HF	2	1.34	1.55	1.73	1.93	2.12	2.29	1.07	1.20	1.34	1.47	1.58	1.69	0.70	0.78	0.88	0.96	1.04	1.11
HF	2-1/2	1.72	1.99	2.22	2.48	2.72	2.94	1.37	1.53	1.71	1.88	2.03	2.17	0.90	1.01	1.13	1.23	1.33	1.42
HF	3	2.26	2.61	2.92	3.26	3.57	3.86	1.81	2.02	2.26	2.48	2.68	2.86	1.19	1.33	1.49	1.63	1.76	1.88
HF	5-1/2	4.03	4.65	5.20	5.82	6.37	6.88	3.22	3.60	4.03	4.41	4.76	5.09	2.12	2.37	2.65	2.90	3.14	3.35
HF	8	5.61	6.48	7.24	8.10	8.87	9.58	4.48	5.01	5.60	6.13	6.63	7.08	2.95	3.30	3.69	4.04	4.36	4.66
HF	10	7.10	8.20	9.17	10.25	11.23	12.13	5.67	6.34	7.09	7.76	8.39	8.97	3.73	4.17	4.66	5.11	5.52	5.90
HF	15	10.53	12.16	13.59	15.20	16.65	17.98	8.40	9.39	10.50	11.50	12.42	13.28	5.53	6.18	6.91	7.57	8.18	8.74
HF	20	13.86	16.00	17.89	20.01	21.91	23.67	11.06	12.37	13.83	15.14	16.36	17.49	7.28	8.14	9.10	9.97	10.77	11.51
TFE	8	5.50	6.35	7.10	7.94	8.70	9.39	4.39	4.91	5.49	6.01	6.49	6.94	2.89	3.23	3.61	3.96	4.27	4.57
TFE	10	7.54	8.71	9.73	10.88	11.92	12.88	6.02	6.73	7.53	8.24	8.90	9.52	3.96	4.43	4.95	5.42	5.86	6.26
TFE	12	9.35	10.80	12.07	13.50	14.78	15.97	7.47	8.35	9.34	10.23	11.05	11.81	4.92	5.50	6.15	6.74	7.28	7.78
TFE	20	14.28	16.49	18.44	20.61	22.58	24.39	11.40	12.75	14.25	15.61	16.86	18.02	7.51	8.40	9.39	10.28	11.11	11.87
TRAE+	10	8.10	9.35	10.46	11.69	12.81	13.83	6.47	7.23	8.09	8.86	9.57	10.23	4.26	4.76	5.33	5.83	6.30	6.74
TRAE+	15	11.80	13.63	15.23	17.03	18.66	20.15	9.42	10.53	11.78	12.90	13.93	14.89	6.21	6.94	7.76	8.50	9.18	9.82
TRAE+	20	13.18	15.22	17.02	19.02	20.84	22.51	10.52	11.76	13.15	14.41	15.56	16.63	6.93	7.75	8.66	9.49	10.25	10.96
TRAE+	30	19.97	23.06	25.78	28.82	31.58	34.11	15.94	17.82	19.93	21.83	23.58	25.20	10.50	11.74	13.13	14.38	15.53	16.60
TRAE+	40	27.45	31.70	35.44	39.62	43.40	46.88	21.92	24.51	27.40	30.02	32.42	34.66	14.43	16.13	18.04	19.76	21.34	22.82
TRAE	50	37.06	42.79	47.84	53.49	58.60	63.29	29.59	33.08	36.99	40.52	43.76	46.79	19.48	21.78	24.35	26.67	28.81	30.80
TRAE	60	40.42	46.67	52.18	58.34	63.91	69.03	32.27	36.08	40.34	44.19	47.73	51.02	21.25	23.76	26.56	29.10	31.43	33.60
TRAE	70	48.11	55.55	62.11	69.44	76.07	82.16	38.41	42.94	48.01	52.60	56.81	60.73	25.29	28.28	31.61	34.63	37.40	39.99
TJR	14	10.09	11.65	13.03	14.56	15.95	17.23	8.05	9.00	10.06	11.02	11.91	12.73	5.30	5.93	6.63	7.26	7.84	8.38
TJR	18	12.08	13.95	15.60	17.44	19.10	20.63	9.64	10.78	12.05	13.20	14.26	15.24	6.35	7.10	7.94	8.70	9.39	10.04
TER	22	15.10	17.44	19.49	21.79	23.88	25.79	12.05	13.47	15.06	16.50	17.82	19.05	7.94	8.88	9.93	10.87	11.74	12.55
TER	26	17.84	20.60	23.03	25.75	28.21	30.47	14.25	15.93	17.81	19.51	21.08	22.53	9.38	10.49	11.73	12.84	13.87	14.83
TER	35	24.02	27.74	31.01	34.67	37.98	41.02	19.18	21.44	23.98	26.26	28.37	30.33	12.63	14.12	15.79	17.29	18.68	19.97
TER	45	30.88	35.66	39.87	44.57	48.83	52.74	24.66	27.57	30.83	33.77	36.47	38.99	16.24	18.16	20.30	22.24	24.02	25.68
TIR	55	37.75	43.59	48.74	54.49	59.69	64.47	30.13	33.69	37.66	41.26	44.56	47.64	19.84	22.18	24.80	27.17	29.34	31.37
THR	75	48.04	55.47	62.02	69.34	75.96	82.04	38.35	42.88	47.94	52.51	56.72	60.64	25.26	28.24	31.58	34.59	37.36	39.94
THR	85	58.33	67.35	75.30	84.19	92.23	99.62	46.57	52.07	58.21	63.77	68.88	73.63	30.67	34.29	38.34	42.00	45.36	48.49
TMR	100	68.63	79.25	88.60	99.06	108.51	117.21	54.79	61.26	68.49	75.02	81.04	86.63	36.08	40.34	45.10	49.40	53.36	57.05

NOTE: Standard capacity is rated at 100°F liquid inlet and 40°F evaporator temperature; with 60 PSI pressure drop across the TXV per ARI 750-2001.

Refrigerant liquid temperature correction factors

	Refrigerant liquid temperature °F															
	0	10	20	30	40	50	60	70	80	90	100	110	120	130	140	
R-22	1.56	1.51	1.45	1.40	1.34	1.29	1.23	1.17	1.12	1.06	1.00	0.94	0.88	0.82	0.76	

NOTE: These factors include corrections for liquid refrigerant density and net refrigerating effect and are based on an average evaporator temperature of 0°F. However, they may be used for any evaporator temperature from -40°F to +40°F since the variation in the actual factors across this range is insignificant.

R-32 balanced ported valves (tons) NXT Series

Valve type	Nom. rating	Evaporator temperature																				
		50°F							40°F							20°F						
		Pressure drop across valve (psi)							Pressure drop across valve (psi)							Pressure drop across valve (psi)						
	75	110	140	160	210	240	285	75	110	140	160	210	240	285	75	110	140	160	210	240	285	
NXT Series	1/2	0.6	0.7	0.8	0.9	1.0	1.1	1.2	0.6	0.7	0.8	0.9	1.0	1.1	1.2	0.6	0.7	0.8	0.9	1.0	1.1	1.2
	1	1.0	1.3	1.4	1.5	1.7	1.9	2.0	1.0	1.2	1.4	1.5	1.7	1.8	2.0	1.0	1.2	1.4	1.5	1.7	1.8	2.0
	1-1/2	1.9	2.3	2.5	2.7	3.1	3.3	3.6	1.9	2.3	2.5	2.7	3.1	3.3	3.6	1.8	2.2	2.5	2.7	3.1	3.3	3.6
	2	2.5	3.0	3.4	3.6	4.2	4.4	4.8	2.5	3.0	3.4	3.6	4.1	4.4	4.8	2.5	3.0	3.4	3.6	4.1	4.4	4.8
	2-1/2	3.3	4.0	4.5	4.8	5.5	5.9	6.5	3.3	4.0	4.5	4.8	5.5	5.9	6.4	3.3	4.0	4.5	4.8	5.5	5.9	6.4
	3	3.7	4.5	5.1	5.4	6.2	6.6	7.2	3.7	4.5	5.1	5.4	6.2	6.6	7.2	3.7	4.4	5.0	5.4	6.1	6.6	7.2
	4	4.8	5.9	6.6	7.1	8.1	8.7	9.4	4.8	5.8	6.6	7.0	8.1	8.6	9.4	4.8	5.8	6.5	7.0	8.0	8.6	9.3
	5	5.3	6.5	7.3	7.8	8.9	9.6	10.4	5.3	6.5	7.3	7.8	8.9	9.5	10.4	5.3	6.4	7.2	7.7	8.8	9.5	10.3
	6	6.0	7.3	8.3	8.8	10.1	10.8	11.8	6.0	7.3	8.2	8.8	10.1	10.8	11.8	6.0	7.2	8.2	8.7	10.0	10.7	11.6
	7	6.5	7.9	8.9	9.6	10.9	11.7	12.8	6.5	7.9	8.9	9.5	10.9	11.7	12.7	6.5	7.8	8.8	9.4	10.8	11.6	12.6
	8	7.7	9.3	10.5	11.2	12.8	13.7	14.9	7.6	9.3	10.4	11.2	12.8	13.7	14.9	7.6	9.2	10.4	11.1	12.7	13.6	14.8
	10	9.4	11.4	12.8	13.7	15.7	16.8	18.3	9.4	11.3	12.8	13.7	15.7	16.8	18.3	9.3	11.2	12.7	13.6	15.5	16.6	18.1
	12	10.9	13.3	15.0	16.0	18.3	19.6	21.3	10.9	13.2	14.9	15.9	18.3	19.5	21.3	10.8	13.1	14.8	15.8	18.1	19.4	21.1
	15	13.8	16.7	18.8	20.1	23.1	24.7	26.9	13.7	16.6	18.8	20.1	23.0	24.6	26.8	13.6	16.5	18.6	19.9	22.8	24.4	26.6

Valve type	Nom. Rating	Evaporator temperature																				
		0°F							-20°F							-40°F						
		Pressure drop across valve (psi)							Pressure drop across valve (psi)							Pressure drop across valve (psi)						
	75	110	140	160	210	240	285	75	110	140	160	210	240	285	75	110	140	160	210	240	285	
NXT Series	1/2	0.6	0.7	0.8	0.9	1.0	1.1	1.2	0.6	0.7	0.8	0.9	1.0	1.1	1.1	0.4	0.5	0.6	0.6	0.7	0.8	0.8
	1	1.0	1.2	1.4	1.5	1.7	1.8	2.0	1.0	1.2	1.4	1.4	1.7	1.8	1.9	0.7	0.9	1.0	1.1	1.2	1.3	1.4
	1-1/2	1.8	2.2	2.5	2.7	3.0	3.3	3.5	1.8	2.2	2.4	2.6	3.0	3.2	3.5	1.3	1.6	1.8	1.9	2.2	2.3	2.6
	2	2.4	2.9	3.3	3.5	4.1	4.3	4.7	2.4	2.9	3.3	3.5	4.0	4.3	4.6	1.7	2.1	2.4	2.6	2.9	3.1	3.4
	2-1/2	3.2	3.9	4.4	4.7	5.4	5.8	6.3	3.2	3.9	4.3	4.6	5.3	5.7	6.2	2.3	2.8	3.2	3.4	3.9	4.2	4.5
	3	3.6	4.4	4.9	5.3	6.1	6.5	7.1	3.6	4.3	4.9	5.2	6.0	6.4	6.9	2.6	3.2	3.6	3.8	4.4	4.7	5.1
	4	4.7	5.7	6.4	6.9	7.9	8.4	9.2	4.6	5.6	6.3	6.8	7.8	8.3	9.0	3.4	4.1	4.7	5.0	5.7	6.1	6.6
	5	5.2	6.3	7.1	7.6	8.7	9.3	10.2	5.1	6.2	7.0	7.5	8.6	9.2	10.0	3.8	4.6	5.1	5.5	6.3	6.7	7.3
	6	5.9	7.1	8.1	8.6	9.9	10.6	11.5	5.8	7.0	7.9	8.5	9.7	10.4	11.3	4.3	5.2	5.8	6.2	7.1	7.6	8.3
	7	6.4	7.7	8.7	9.3	10.7	11.4	12.4	6.3	7.6	8.6	9.2	10.5	11.2	12.2	4.6	5.6	6.3	6.7	7.7	8.2	9.0
	8	7.5	9.1	10.2	10.9	12.5	13.4	14.6	7.4	8.9	10.1	10.7	12.3	13.2	14.3	5.4	6.5	7.4	7.9	9.0	9.7	10.5
	10	9.2	11.1	12.5	13.4	15.3	16.4	17.9	9.0	10.9	12.3	13.2	15.1	16.1	17.6	6.6	8.0	9.0	9.7	11.1	11.8	12.9
	12	10.7	12.9	14.6	15.6	17.9	19.1	20.8	10.5	12.7	14.3	15.3	17.6	18.8	20.5	7.7	9.3	10.5	11.2	12.9	13.8	15.0
	15	13.4	16.3	18.4	19.6	22.5	24.1	26.2	13.2	16.0	18.1	19.3	22.1	23.7	25.8	9.7	11.7	13.3	14.2	16.2	17.4	18.9

NOTE: Standard capacity is rated at 100°F liquid inlet and 40°F evap temperature; with 160 PSI pressure drop across TXV per ARI-7.50-2001. These ratings assume vapor free liquid entering the thermal expansion valve.

Refrigerant liquid temperature correction factors

	Refrigerant liquid temperature °F									
	50	60	70	80	90	100	110	120	130	140
R-32	1.30	1.24	1.18	1.12	1.06	1.00	0.94	0.87	0.80	0.73

NOTE: These factors include corrections for liquid refrigerant density and net refrigeration effect, and are based on an average evaporator temperature of 0°F with a maximum 7°F Change in Superheat. However, they may be used for any evaporator temperature from -40°F to +40°F since the variation in the actual factors across this range is insignificant.

R-134A balanced ported valves (tons) NXT-R / B / HF / TFE / TRAE / T Series

Valve type	Nom. rating	Evaporator temperature																	
		50°F						40°F						20°F					
		Pressure drop across valve (psi)						Pressure drop across valve (psi)						Pressure drop across valve (psi)					
		60	80	100	125	150	175	60	80	100	125	150	175	60	80	100	125	150	175
NXT-R	1/8	0.06	0.07	0.08	0.09	0.1	0.11	0.06	0.07	0.08	0.09	0.1	0.1	0.05	0.05	0.06	0.07	0.07	0.08
NXT-R	1/4	0.16	0.19	0.21	0.23	0.25	0.27	0.16	0.18	0.2	0.23	0.25	0.27	0.12	0.14	0.16	0.18	0.19	0.21
NXT-R	1/2	0.27	0.31	0.35	0.39	0.42	0.46	0.26	0.3	0.34	0.38	0.42	0.45	0.2	0.23	0.26	0.29	0.32	0.35
NXT-R	3/4	0.36	0.41	0.46	0.52	0.57	0.61	0.35	0.41	0.45	0.51	0.56	0.6	0.27	0.31	0.35	0.39	0.43	0.46
NXT-R	1	0.64	0.74	0.83	0.93	1.02	1.1	0.63	0.73	0.81	0.91	1	1.08	0.49	0.56	0.63	0.7	0.77	0.83
NXT-R	1 1/2	0.86	0.99	1.11	1.24	1.36	1.47	0.84	0.97	1.08	1.21	1.33	1.44	0.65	0.75	0.83	0.93	1.02	1.1
NXT-R	2	1.14	1.32	1.48	1.65	1.81	1.95	1.12	1.29	1.44	1.62	1.77	1.91	0.86	0.99	1.11	1.24	1.36	1.47
NXT-R	2 1/4	1.28	1.48	1.65	1.85	2.02	2.18	1.25	1.45	1.62	1.81	1.98	2.14	0.96	1.11	1.24	1.39	1.52	1.65
NXT-R	2 1/2	1.67	1.92	2.15	2.41	2.64	2.85	1.63	1.88	2.11	2.36	2.58	2.79	1.26	1.45	1.62	1.81	1.99	2.15
NXT-R	3	1.84	2.13	2.38	2.66	2.92	3.15	1.81	2.09	2.33	2.61	2.86	3.08	1.39	1.6	1.79	2.01	2.2	2.37
NXT-R	3 1/2	2.08	2.41	2.69	3.01	3.29	3.56	2.04	2.36	2.63	2.94	3.23	3.48	1.57	1.81	2.03	2.27	2.48	2.68
NXT-R	4	2.25	2.6	2.91	3.25	3.56	3.85	2.21	2.55	2.85	3.18	3.49	3.77	1.7	1.96	2.19	2.45	2.68	2.9
BA/BN	1/2	0.37	0.43	0.48	0.53	0.59	0.63	0.37	0.43	0.48	0.53	0.59	0.63	0.35	0.40	0.45	0.51	0.55	0.60
BA/BN	3/4	0.71	0.82	0.92	1.02	1.12	1.21	0.70	0.81	0.90	1.01	1.11	1.20	0.67	0.77	0.86	0.97	1.06	1.14
BA/BN	1	1.11	1.28	1.43	1.60	1.76	1.90	1.09	1.26	1.41	1.57	1.72	1.86	1.04	1.20	1.34	1.50	1.64	1.78
BA/BN	1-1/2	1.48	1.71	1.91	2.14	2.34	2.53	1.45	1.67	1.87	2.09	2.29	2.48	1.39	1.61	1.79	2.01	2.20	2.37
BA/BN	2	1.87	2.16	2.41	2.70	2.96	3.19	1.84	2.12	2.38	2.66	2.91	3.14	1.76	2.03	2.27	2.54	2.78	3.01
BA/BN	2-1/4	2.27	2.62	2.93	3.28	3.59	3.88	2.22	2.56	2.87	3.20	3.51	3.79	2.13	2.46	2.75	3.07	3.37	3.64
BA/BN	3	2.94	3.39	3.80	4.24	4.65	5.02	2.88	3.33	3.72	4.16	4.55	4.92	2.75	3.18	3.55	3.97	4.35	4.70
BA/BN	3-1/2	3.72	4.30	4.80	5.37	5.88	6.35	3.64	4.20	4.70	5.25	5.76	6.22	3.48	4.02	4.49	5.02	5.50	5.94
BA/BN	4-1/4	4.62	5.33	5.96	6.67	7.30	7.89	4.53	5.23	5.85	6.54	7.16	7.74	4.33	5.00	5.59	6.25	6.85	7.39
HF	1/4	0.21	0.24	0.27	0.30	0.33	0.36	0.21	0.24	0.27	0.30	0.33	0.36	0.20	0.23	0.26	0.29	0.32	0.34
HF	1/2	0.40	0.46	0.52	0.58	0.63	0.68	0.39	0.45	0.50	0.56	0.62	0.67	0.37	0.43	0.48	0.53	0.59	0.63
HF	3/4	0.71	0.82	0.92	1.02	1.12	1.21	0.70	0.81	0.90	1.01	1.11	1.20	0.67	0.77	0.86	0.97	1.06	1.14
HF	1	1.09	1.26	1.41	1.57	1.72	1.86	1.06	1.22	1.37	1.53	1.68	1.81	1.02	1.18	1.32	1.47	1.61	1.74
HF	1-1/2	1.46	1.69	1.88	2.11	2.31	2.49	1.43	1.65	1.85	2.06	2.26	2.44	1.37	1.58	1.77	1.98	2.17	2.34
HF	1-3/4	1.87	2.16	2.41	2.70	2.96	3.19	1.84	2.12	2.38	2.66	2.91	3.14	1.76	2.03	2.27	2.54	2.78	3.01
HF	2-1/2	2.47	2.85	3.19	3.57	3.91	4.22	2.42	2.79	3.12	3.49	3.83	4.13	2.32	2.68	3.00	3.35	3.67	3.96
HF	4	4.40	5.08	5.68	6.35	6.96	7.51	4.31	4.98	5.56	6.22	6.81	7.36	4.12	4.76	5.32	5.95	6.51	7.04
HF	6	6.12	7.07	7.90	8.83	9.68	10.45	6.00	6.93	7.75	8.66	9.49	10.25	5.74	6.63	7.41	8.28	9.08	9.80
HF	7-1/2	7.75	8.95	10.01	11.19	12.25	13.24	7.59	8.76	9.80	10.96	12.00	12.96	7.26	8.38	9.37	10.48	11.48	12.40
HF	11	11.50	13.28	14.85	16.60	18.18	19.64	11.26	13.00	14.54	16.25	17.80	19.23	10.77	12.44	13.90	15.55	17.03	18.39
HF	14	15.13	17.47	19.53	21.84	23.92	25.84	14.82	17.11	19.13	21.39	23.43	25.31	14.18	16.37	18.31	20.47	22.42	24.22
TFE	6	6.01	6.94	7.76	8.67	9.50	10.26	5.89	6.80	7.60	8.50	9.31	10.06	5.63	6.50	7.27	8.13	8.90	9.62
TFE	8	8.23	9.50	10.62	11.88	13.01	14.06	8.06	9.31	10.41	11.63	12.74	13.77	7.71	8.90	9.95	11.13	12.19	13.17
TFE	10	10.22	11.80	13.19	14.75	16.16	17.45	10.01	11.56	12.92	14.45	15.83	17.10	9.57	11.05	12.35	13.81	15.13	16.34
TFE	15	15.60	18.01	20.14	22.52	24.67	26.64	15.28	17.64	19.73	22.05	24.16	26.10	14.61	16.87	18.86	21.09	23.10	24.95
TRAE+	9	8.84	10.21	11.41	12.76	13.98	15.10	8.66	10.00	11.18	12.50	13.69	14.79	8.29	9.57	10.70	11.97	13.11	14.16
TRAE+	13	12.89	14.88	16.64	18.61	20.38	22.01	12.63	14.58	16.31	18.23	19.97	21.57	12.08	13.95	15.60	17.44	19.10	20.63
TRAE+	14	14.39	16.62	18.58	20.77	22.75	24.58	14.09	16.27	18.19	20.34	22.28	24.06	13.48	15.57	17.40	19.46	21.31	23.02
TRAE+	22	21.81	25.18	28.16	31.48	34.48	37.25	21.36	24.66	27.58	30.83	33.77	36.48	20.43	23.59	26.38	29.49	32.30	34.89
TRAE+	30	29.98	34.62	38.70	43.27	47.40	51.20	29.36	33.90	37.90	42.38	46.42	50.14	28.09	32.44	36.26	40.54	44.41	47.97
TRAE	40	40.48	46.74	52.26	58.43	64.00	69.13	39.64	45.77	51.18	57.22	62.68	67.70	37.92	43.79	48.95	54.73	59.96	64.76
TRAE	45	44.15	50.98	57.00	63.73	69.81	75.40	43.24	49.93	55.82	62.41	68.37	73.85	41.36	47.76	53.40	59.70	65.40	70.64
TRAE	50	52.54	60.67	67.83	75.83	83.07	89.73	51.46	59.42	66.43	74.28	81.37	87.88	49.22	56.83	63.54	71.04	77.82	84.06
TJR	11	11.02	12.72	14.23	15.91	17.42	18.82	10.79	12.46	13.93	15.57	17.06	18.43	10.32	11.92	13.32	14.90	16.32	17.62
TJR	13	13.19	15.23	17.03	19.04	20.86	22.53	12.92	14.92	16.68	18.65	20.43	22.07	12.36	14.27	15.96	17.84	19.54	21.11
TER	16	16.49	19.04	21.29	23.80	26.07	28.16	16.15	18.65	20.85	23.31	25.54	27.58	15.45	17.84	19.95	22.30	24.43	26.39
TER	19	19.49	22.51	25.16	28.13	30.82	33.29	19.09	22.04	24.65	27.55	30.18	32.60	18.26	21.08	23.57	26.36	28.87	31.18
TER	25	26.23	30.29	33.86	37.86	41.47	44.80	25.69	29.66	33.17	37.08	40.62	43.87	24.58	28.38	31.73	35.48	38.86	41.98
TER	31	33.73	38.95	43.55	48.69	53.33	57.60	33.03	38.14	42.64	47.67	52.23	56.41	31.60	36.49	40.80	45.61	49.96	53.97
TIR	45	41.23	47.61	53.23	59.51	65.19	70.41	40.37	46.62	52.12	58.27	63.83	68.94	38.62	44.59	49.86	55.74	61.06	65.96
THR	55	52.47	60.59	67.74	75.73	82.96	89.61	51.38	59.33	66.33	74.16	81.24	87.75	49.15	56.75	63.45	70.94	77.71	83.94
THR	68	63.71	73.57	82.25	91.96	100.73	108.81	62.40	72.05	80.56	90.07	98.66	106.57	59.69	68.92	77.06	86.16	94.38	101.94
TMR	68	74.95	86.54	96.76	108.18	118.51	128.00	73.41	84.77	94.77	105.96	116.07	125.37	70.22	81.08	90.65	101.35	111.03	119.92

R-134A balanced ported valves (tons) NXT-R / B / HF / TFE / TRAE / T Series (cont.)

Valve type	Nom. rating	Evaporator temperature																	
		0°F						-20°F						-40°F					
		Pressure drop across valve (psi)						Pressure drop across valve (psi)						Pressure drop across valve (psi)					
		60	80	100	125	150	175	80	100	125	150	175	200	80	100	125	150	175	200
NXT-R	1/8	0.03	0.04	0.04	0.05	0.05	0.05	0.02	0.03	0.03	0.03	0.03	0.04	0.01	0.02	0.02	0.02	0.02	0.02
NXT-R	1/4	0.08	0.09	0.11	0.12	0.13	0.14	0.06	0.07	0.08	0.08	0.09	0.1	0.04	0.04	0.05	0.05	0.06	0.06
NXT-R	1/2	0.14	0.16	0.18	0.2	0.22	0.23	0.1	0.11	0.13	0.14	0.15	0.16	0.06	0.07	0.08	0.09	0.09	0.1
NXT-R	3/4	0.18	0.21	0.24	0.26	0.29	0.31	0.14	0.15	0.17	0.19	0.2	0.22	0.08	0.09	0.1	0.11	0.12	0.13
NXT-R	1	0.33	0.38	0.42	0.47	0.52	0.56	0.25	0.27	0.31	0.34	0.36	0.39	0.15	0.17	0.19	0.21	0.22	0.24
NXT-R	1 1/2	0.44	0.51	0.56	0.63	0.69	0.75	0.33	0.37	0.41	0.45	0.48	0.52	0.2	0.22	0.25	0.27	0.3	0.32
NXT-R	2	0.58	0.67	0.75	0.84	0.92	1	0.44	0.49	0.54	0.6	0.64	0.69	0.27	0.3	0.33	0.37	0.4	0.42
NXT-R	2 1/4	0.65	0.75	0.84	0.94	1.03	1.11	0.49	0.54	0.61	0.67	0.72	0.77	0.3	0.33	0.37	0.41	0.44	0.47
NXT-R	2 1/2	0.85	0.98	1.1	1.23	1.34	1.45	0.63	0.71	0.79	0.87	0.94	1	0.39	0.44	0.49	0.53	0.58	0.62
NXT-R	3	0.94	1.09	1.21	1.36	1.49	1.61	0.7	0.79	0.88	0.96	1.04	1.11	0.43	0.48	0.54	0.59	0.64	0.68
NXT-R	3 1/2	1.06	1.23	1.37	1.53	1.68	1.81	0.79	0.89	0.99	1.09	1.17	1.25	0.49	0.54	0.61	0.67	0.72	0.77
NXT-R	4	1.15	1.33	1.48	1.66	1.82	1.96	0.86	0.96	1.07	1.17	1.27	1.36	0.53	0.59	0.66	0.72	0.78	0.83
BA/BN	1/2	0.29	0.33	0.37	0.42	0.46	0.5	0.22	0.25	0.28	0.3	0.33	0.35	0.13	0.15	0.16	0.18	0.19	0.21
BA/BN	3/4	0.55	0.64	0.71	0.79	0.87	0.94	0.41	0.46	0.51	0.56	0.61	0.65	0.25	0.28	0.31	0.34	0.37	0.4
BA/BN	1	0.86	0.99	1.11	1.24	1.36	1.47	0.64	0.72	0.8	0.88	0.95	1.01	0.39	0.44	0.49	0.53	0.58	0.62
BA/BN	1-1/2	1.14	1.32	1.47	1.65	1.8	1.95	0.85	0.95	1.06	1.16	1.26	1.34	0.52	0.58	0.65	0.71	0.77	0.82
BA/BN	2	1.44	1.66	1.86	2.08	2.28	2.46	1.08	1.21	1.35	1.48	1.6	1.71	0.66	0.74	0.83	0.9	0.98	1.04
BA/BN	2-1/4	1.75	2.02	2.26	2.53	2.77	2.99	1.31	1.46	1.64	1.79	1.94	2.07	0.8	0.89	1	1.1	1.18	1.26
BA/BN	3	2.27	2.62	2.93	3.28	3.59	3.88	1.69	1.89	2.11	2.31	2.5	2.67	1.04	1.16	1.3	1.42	1.54	1.64
BA/BN	3-1/2	2.87	3.31	3.71	4.14	4.54	4.9	2.14	2.39	2.68	2.93	3.17	3.38	1.31	1.46	1.64	1.79	1.94	2.07
BA/BN	4-1/4	3.57	4.12	4.61	5.15	5.64	6.1	2.66	2.97	3.33	3.64	3.93	4.21	1.63	1.82	2.04	2.23	2.41	2.58
HF	1/4	0.16	0.18	0.21	0.23	0.25	0.27	0.12	0.13	0.15	0.16	0.18	0.19	0.07	0.08	0.09	0.1	0.1	0.11
HF	1/2	0.31	0.36	0.4	0.45	0.49	0.53	0.23	0.26	0.29	0.31	0.34	0.36	0.14	0.16	0.18	0.19	0.21	0.22
HF	3/4	0.55	0.64	0.71	0.79	0.87	0.94	0.41	0.46	0.51	0.56	0.61	0.65	0.25	0.28	0.31	0.34	0.37	0.4
HF	1	0.84	0.97	1.08	1.21	1.33	1.43	0.63	0.7	0.79	0.86	0.93	1	0.38	0.42	0.48	0.52	0.56	0.6
HF	1-1/2	1.13	1.3	1.46	1.63	1.79	1.93	0.84	0.94	1.05	1.15	1.24	1.33	0.52	0.58	0.65	0.71	0.77	0.82
HF	1-3/4	1.44	1.66	1.86	2.08	2.28	2.46	1.08	1.21	1.35	1.48	1.6	1.71	0.66	0.74	0.83	0.9	0.98	1.04
HF	2-1/2	1.91	2.21	2.47	2.76	3.02	3.26	1.42	1.59	1.78	1.94	2.1	2.25	0.87	0.97	1.09	1.19	1.29	1.38
HF	4	3.39	3.91	4.38	4.89	5.36	5.79	2.53	2.83	3.16	3.46	3.74	4	1.55	1.73	1.94	2.12	2.29	2.45
HF	6	4.72	5.45	6.09	6.81	7.46	8.06	3.52	3.94	4.4	4.82	5.21	5.57	2.16	2.41	2.7	2.96	3.19	3.42
HF	7-1/2	5.98	6.91	7.72	8.63	9.46	10.21	4.46	4.99	5.58	6.11	6.6	7.05	2.74	3.06	3.43	3.75	4.05	4.33
HF	11	8.87	10.24	11.45	12.8	14.02	15.15	6.62	7.4	8.28	9.06	9.79	10.47	4.06	4.54	5.08	5.56	6	6.42
HF	14	11.67	13.48	15.07	16.84	18.45	19.93	8.71	9.74	10.89	11.93	12.88	13.77	5.34	5.97	6.68	7.31	7.9	8.44
TFE	6	4.64	5.36	5.99	6.7	7.34	7.92	3.46	3.87	4.33	4.74	5.12	5.47	2.12	2.37	2.65	2.9	3.14	3.35
TFE	8	6.35	7.33	8.2	9.17	10.04	10.84	4.74	5.3	5.93	6.49	7.01	7.49	2.91	3.25	3.64	3.98	4.3	4.6
TFE	10	7.88	9.1	10.17	11.37	12.46	13.46	5.88	6.57	7.35	8.05	8.7	9.3	3.61	4.04	4.51	4.94	5.34	5.71
TFE	15	12.03	13.89	15.53	17.36	19.02	20.55	8.97	10.03	11.21	12.28	13.27	14.18	5.51	6.16	6.89	7.54	8.15	8.71
TRAE+	9	6.82	7.88	8.8	9.84	10.78	11.65	5.09	5.69	6.36	6.97	7.53	8.05	3.12	3.49	3.9	4.27	4.61	4.93
TRAE+	13	9.94	11.48	12.83	14.35	15.72	16.98	7.42	8.3	9.28	10.16	10.97	11.73	4.55	5.09	5.69	6.23	6.73	7.19
TRAE+	14	11.1	12.82	14.33	16.02	17.55	18.96	8.28	9.26	10.35	11.34	12.25	13.09	5.08	5.68	6.35	6.96	7.51	8.03
TRAE+	22	16.82	19.42	21.71	24.28	26.59	28.73	12.55	14.03	15.69	17.18	18.56	19.84	7.7	8.61	9.63	10.54	11.39	12.17
TRAE+	30	23.12	26.7	29.85	33.37	36.56	39.48	17.25	19.29	21.56	23.62	25.51	27.27	10.59	11.84	13.24	14.5	15.66	16.74
TRAE	40	31.21	36.04	40.29	45.05	49.35	53.3	23.29	26.04	29.11	31.89	34.45	36.82	14.29	15.98	17.86	19.57	21.14	22.59
TRAE	45	34.04	39.31	43.95	49.13	53.82	58.13	25.4	28.4	31.75	34.78	37.57	40.16	15.59	17.43	19.49	21.35	23.06	24.65
TRAE	50	40.52	46.79	52.31	58.49	64.07	69.2	30.23	33.8	37.79	41.39	44.71	47.8	18.55	20.74	23.19	25.4	27.44	29.33
TJR	11	8.5	9.81	10.97	12.27	13.44	14.52	6.34	7.09	7.93	8.68	9.38	10.02	3.89	4.35	4.86	5.33	5.75	6.15
TJR	13	10.17	11.74	13.13	14.68	16.08	17.37	7.59	8.49	9.49	10.39	11.23	12	4.66	5.21	5.83	6.38	6.89	7.37
TER	16	12.72	14.69	16.42	18.36	20.11	21.72	9.49	10.61	11.86	12.99	14.04	15.01	5.82	6.51	7.28	7.97	8.61	9.2
TER	19	15.03	17.36	19.4	21.69	23.76	25.67	11.21	12.53	14.01	15.35	16.58	17.72	6.88	7.69	8.6	9.42	10.18	10.88
TER	25	20.23	23.36	26.12	29.2	31.99	34.55	15.09	16.87	18.86	20.66	22.32	23.86	9.26	10.35	11.58	12.68	13.7	14.64
TER	31	26.01	30.03	33.58	37.54	41.13	44.42	19.41	21.7	24.26	26.58	28.71	30.69	11.91	13.32	14.89	16.31	17.62	18.83

NOTE: Standard capacity is rated at 100°F liquid inlet and 40°F evaporator temperature; with 60 PSI pressure drop across the TXV per ARI 750-2001.

R-134A balanced ported valves (tons) NXT-R / B / HF / TFE / TRAE / T Series (cont.)

Valve type	Nom. rating	Evaporator temperature																	
		0°F						-20°F						-40°F					
		Pressure drop across valve (psi)						Pressure drop across valve (psi)						Pressure drop across valve (psi)					
		60	80	100	125	150	175	80	100	125	150	175	200	80	100	125	150	175	200
TIR	45	31.79	36.71	41.04	45.88	50.26	54.29	23.72	26.52	29.65	32.48	35.08	37.5	14.56	16.28	18.2	19.94	21.53	23.02
THR	55	40.46	46.72	52.23	58.4	63.97	69.1	30.19	33.75	37.74	41.34	44.65	47.73	18.53	20.72	23.16	25.37	27.41	29.3
THR	68	49.13	56.73	63.43	70.91	77.68	83.91	36.66	40.99	45.83	50.2	54.22	57.96	22.5	25.16	28.13	30.81	33.28	35.58
TMR	68	57.8	66.74	74.62	83.43	91.39	98.71	43.12	48.21	53.9	59.04	63.78	68.18	26.47	29.59	33.09	36.25	39.15	41.85

Refrigerant liquid temperature correction factors

	Refrigerant liquid temperature °F														
	0	10	20	30	40	50	60	70	80	90	100	110	120	130	140
R-134a	1.70	1.63	1.56	1.49	1.42	1.36	1.29	1.21	1.14	1.07	1.00	0.93	0.85	0.78	0.71

NOTE: These factors include corrections for liquid refrigerant density and net refrigeration effect, and are based on an average evaporator temperature of 0°F with a maximum 7°F Change in Superheat. However, they may be used for any evaporator temperature from -40°F to +40°F since the variation in the actual factors across this range is insignificant.

R-290 balance ported valves (tons) NXT-R / B / H Series

Valve type	Nom. rating	Evaporator temperature																	
		50°F						40°F						20°F					
		Pressure drop across valve (psi)						Pressure drop across valve (psi)						Pressure drop across valve (psi)					
		60	80	100	125	150	175	60	80	100	125	150	175	60	80	100	125	150	175
NXT-R	1/10	0.04	0.05	0.06	0.06	0.07	0.07	0.04	0.05	0.06	0.06	0.07	0.07	0.04	0.05	0.05	0.06	0.06	0.07
NXT-R	1/5	0.11	0.13	0.14	0.16	0.17	0.19	0.11	0.12	0.14	0.15	0.17	0.18	0.1	0.12	0.13	0.15	0.16	0.17
NXT-R	1/4	0.28	0.33	0.37	0.41	0.45	0.49	0.28	0.32	0.36	0.4	0.44	0.48	0.27	0.31	0.34	0.38	0.42	0.45
NXT-R	1/2	0.47	0.55	0.61	0.68	0.75	0.81	0.46	0.54	0.6	0.67	0.73	0.79	0.44	0.51	0.57	0.64	0.7	0.76
NXT-R	1	0.63	0.73	0.82	0.92	1	1.08	0.62	0.72	0.8	0.9	0.98	1.06	0.59	0.69	0.77	0.86	0.94	1.01
NXT-R	1 1/2	1.14	1.31	1.47	1.64	1.8	1.94	1.11	1.29	1.44	1.61	1.76	1.9	1.07	1.23	1.38	1.54	1.68	1.82
NXT-R	2 1/2	1.52	1.75	1.96	2.19	2.4	2.59	1.49	1.72	1.92	2.14	2.35	2.54	1.42	1.64	1.83	2.05	2.25	2.43
NXT-R	3	2.02	2.33	2.61	2.92	3.2	3.45	1.98	2.29	2.55	2.86	3.13	3.38	1.89	2.18	2.44	2.73	2.99	3.23
NXT-R	3 1/2	2.26	2.61	2.92	3.26	3.58	3.86	2.21	2.56	2.86	3.2	3.5	3.78	2.12	2.44	2.73	3.06	3.35	3.62
NXT-R	4 1/2	2.95	3.4	3.81	4.25	4.66	5.03	2.89	3.33	3.73	4.17	4.56	4.93	2.76	3.19	3.56	3.98	4.36	4.71
NXT-R	5	3.26	3.77	4.21	4.71	5.16	5.57	3.19	3.69	4.12	4.61	5.05	5.45	3.05	3.52	3.94	4.41	4.83	5.21
NXT-R	5 3/4	3.68	4.25	4.76	5.32	5.83	6.29	3.61	4.17	4.66	5.21	5.7	6.16	3.45	3.98	4.45	4.98	5.45	5.89
BA/BN	1/2	0.36	0.42	0.47	0.53	0.58	0.62	0.36	0.41	0.46	0.52	0.56	0.61	0.34	0.39	0.44	0.49	0.54	0.58
BA/BN	3/4	0.69	0.8	0.89	1	1.1	1.18	0.68	0.78	0.88	0.98	1.07	1.16	0.65	0.75	0.84	0.94	1.03	1.11
BA/BN	1-1/4	1.08	1.25	1.39	1.56	1.71	1.84	1.06	1.22	1.36	1.53	1.67	1.81	1.01	1.17	1.3	1.46	1.6	1.73
BA/BN	1-3/4	1.44	1.67	1.87	2.09	2.28	2.47	1.41	1.63	1.83	2.04	2.24	2.42	1.35	1.56	1.75	1.95	2.14	2.31
BA/BN	2-1/4	1.82	2.11	2.35	2.63	2.88	3.12	1.79	2.06	2.31	2.58	2.82	3.05	1.71	1.97	2.2	2.46	2.7	2.92
BA/BN	2-3/4	2.21	2.55	2.85	3.19	3.5	3.78	2.16	2.5	2.79	3.12	3.42	3.7	2.07	2.39	2.67	2.99	3.27	3.53
BA/BN	3-1/2	2.86	3.3	3.69	4.13	4.52	4.88	2.8	3.23	3.62	4.04	4.43	4.78	2.68	3.09	3.46	3.86	4.23	4.57
BA/BN	4-1/2	3.63	4.19	4.68	5.23	5.73	6.19	3.55	4.1	4.58	5.12	5.61	6.06	3.39	3.92	4.38	4.9	5.37	5.8
BA/BN	5-3/4	4.5	5.2	5.81	6.5	7.12	7.69	4.41	5.09	5.69	6.36	6.97	7.53	4.21	4.87	5.44	6.08	6.66	7.2
HF	1/4	0.2	0.24	0.26	0.29	0.32	0.35	0.2	0.23	0.26	0.29	0.32	0.34	0.19	0.22	0.25	0.28	0.3	0.33
HF	1/2	0.39	0.45	0.5	0.56	0.61	0.66	0.38	0.44	0.49	0.55	0.6	0.65	0.36	0.42	0.47	0.52	0.57	0.62
HF	3/4	0.69	0.8	0.89	1	1.1	1.18	0.68	0.78	0.88	0.98	1.07	1.16	0.65	0.75	0.84	0.94	1.03	1.11
HF	1	1.06	1.22	1.37	1.53	1.67	1.81	1.04	1.2	1.34	1.5	1.64	1.77	0.99	1.14	1.28	1.43	1.57	1.69
HF	1-1/2	1.43	1.65	1.85	2.06	2.26	2.44	1.4	1.62	1.81	2.02	2.21	2.39	1.34	1.55	1.73	1.93	2.12	2.29
HF	2	1.83	2.11	2.36	2.64	2.9	3.13	1.79	2.07	2.31	2.59	2.84	3.06	1.71	1.98	2.21	2.47	2.71	2.93
HF	2-1/2	2.42	2.79	3.12	3.49	3.82	4.12	2.36	2.73	3.05	3.41	3.74	4.04	2.26	2.61	2.92	3.26	3.57	3.86
HF	4-1/2	4.3	4.96	5.55	6.2	6.8	7.34	4.21	4.86	5.43	6.07	6.65	7.19	4.02	4.64	5.19	5.81	6.36	6.87
HF	6-1/2	5.98	6.9	7.71	8.63	9.45	10.21	5.85	6.76	7.55	8.45	9.25	9.99	5.59	6.46	7.22	8.07	8.84	9.55
HF	8	7.59	8.76	9.8	10.95	12	12.96	7.43	8.58	9.59	10.72	11.75	12.69	7.1	8.2	9.17	10.25	11.23	12.13
HF	12	11.24	12.97	14.51	16.22	17.77	19.19	11	12.7	14.2	15.88	17.4	18.79	10.52	12.14	13.58	15.18	16.63	17.96
HF	16	14.74	17.02	19.03	21.27	23.3	25.17	14.43	16.66	18.63	20.83	22.82	24.65	13.79	15.93	17.81	19.91	21.81	23.56

NOTE: Standard capacity is rated at 100F liquid inlet and 40°F evaporator temperature; with 100 PSI pressure drop across the TXV.

R-290 balance ported valves (tons) NXT-R Series, B Series and H Series (cont'd)

Valve type	Nom. rating	Evaporator temperature																	
		0°F						-20°F						-40°F					
		Pressure drop across valve (psi)						Pressure drop across valve (psi)						Pressure drop across valve (psi)					
		60	80	100	125	150	175	80	100	125	150	175	200	80	100	125	150	175	200
NXT-R	1/10	0.03	0.04	0.04	0.05	0.05	0.06	0.03	0.03	0.03	0.04	0.04	0.04	0.02	0.02	0.02	0.02	0.03	0.03
NXT-R	1/5	0.08	0.1	0.11	0.12	0.13	0.14	0.07	0.08	0.08	0.09	0.1	0.11	0.04	0.05	0.06	0.06	0.07	0.07
NXT-R	1/4	0.22	0.25	0.28	0.31	0.34	0.37	0.17	0.2	0.22	0.24	0.26	0.28	0.12	0.13	0.15	0.16	0.17	0.18
NXT-R	1/2	0.36	0.42	0.47	0.52	0.57	0.62	0.29	0.33	0.36	0.4	0.43	0.46	0.19	0.22	0.24	0.27	0.29	0.31
NXT-R	1	0.48	0.56	0.62	0.7	0.76	0.83	0.39	0.44	0.49	0.53	0.58	0.62	0.26	0.29	0.33	0.36	0.39	0.41
NXT-R	1 1/2	0.87	1	1.12	1.25	1.37	1.48	0.7	0.78	0.87	0.96	1.03	1.1	0.47	0.52	0.58	0.64	0.69	0.74
NXT-R	2 1/2	1.16	1.33	1.49	1.67	1.83	1.97	0.93	1.04	1.16	1.27	1.38	1.47	0.62	0.7	0.78	0.85	0.92	0.98
NXT-R	3	1.54	1.78	1.99	2.22	2.43	2.63	1.24	1.39	1.55	1.7	1.83	1.96	0.83	0.93	1.04	1.14	1.23	1.31
NXT-R	3 1/2	1.72	1.99	2.22	2.49	2.72	2.94	1.39	1.55	1.73	1.9	2.05	2.19	0.93	1.04	1.16	1.27	1.37	1.47
NXT-R	4 1/2	2.24	2.59	2.9	3.24	3.55	3.83	1.81	2.02	2.26	2.47	2.67	2.86	1.21	1.35	1.51	1.66	1.79	1.91
NXT-R	5	2.48	2.87	3.21	3.58	3.93	4.24	2	2.24	2.5	2.74	2.96	3.16	1.34	1.5	1.67	1.83	1.98	2.12
NXT-R	5 3/4	2.81	3.24	3.62	4.05	4.44	4.79	2.26	2.53	2.82	3.09	3.34	3.57	1.51	1.69	1.89	2.07	2.24	2.39
BA/BN	1/2	0.28	0.32	0.36	0.4	0.44	0.47	0.22	0.25	0.28	0.31	0.33	0.35	0.15	0.17	0.19	0.2	0.22	0.24
BA/BN	3/4	0.53	0.61	0.68	0.76	0.83	0.9	0.42	0.48	0.53	0.58	0.63	0.67	0.28	0.32	0.36	0.39	0.42	0.45
BA/BN	1-1/4	0.82	0.95	1.06	1.19	1.3	1.4	0.66	0.74	0.83	0.91	0.98	1.05	0.44	0.5	0.55	0.61	0.66	0.7
BA/BN	1-3/4	1.1	1.27	1.42	1.59	1.74	1.88	0.89	0.99	1.11	1.21	1.31	1.4	0.59	0.66	0.74	0.81	0.88	0.94
BA/BN	2-1/4	1.39	1.6	1.79	2	2.2	2.37	1.12	1.25	1.4	1.53	1.65	1.77	0.75	0.84	0.94	1.02	1.11	1.18
BA/BN	2-3/4	1.68	1.94	2.17	2.43	2.66	2.87	1.36	1.52	1.69	1.86	2	2.14	0.91	1.01	1.13	1.24	1.34	1.43
BA/BN	3-1/2	2.18	2.51	2.81	3.14	3.44	3.72	1.75	1.96	2.19	2.4	2.59	2.77	1.17	1.31	1.47	1.61	1.74	1.86
BA/BN	4-1/2	2.76	3.19	3.56	3.98	4.37	4.72	2.22	2.49	2.78	3.04	3.29	3.52	1.49	1.66	1.86	2.04	2.2	2.35
BA/BN	5-3/4	3.43	3.96	4.42	4.95	5.42	5.85	2.76	3.09	3.45	3.78	4.08	4.36	1.85	2.07	2.31	2.53	2.73	2.92
HF	1/4	0.16	0.18	0.2	0.22	0.25	0.27	0.13	0.14	0.16	0.17	0.19	0.2	0.08	0.09	0.1	0.11	0.12	0.13
HF	1/2	0.29	0.34	0.38	0.42	0.47	0.5	0.24	0.27	0.3	0.32	0.35	0.37	0.16	0.18	0.2	0.22	0.23	0.25
HF	3/4	0.53	0.61	0.68	0.76	0.83	0.9	0.42	0.48	0.53	0.58	0.63	0.67	0.28	0.32	0.36	0.39	0.42	0.45
HF	1	0.81	0.93	1.04	1.16	1.27	1.38	0.65	0.73	0.81	0.89	0.96	1.03	0.43	0.49	0.54	0.59	0.64	0.69
HF	1-1/2	1.09	1.26	1.41	1.57	1.72	1.86	0.88	0.98	1.1	1.2	1.3	1.39	0.59	0.66	0.73	0.8	0.87	0.93
HF	2	1.39	1.61	1.8	2.01	2.2	2.38	1.12	1.26	1.4	1.54	1.66	1.78	0.75	0.84	0.94	1.03	1.11	1.19
HF	2-1/2	1.84	2.12	2.37	2.65	2.91	3.14	1.48	1.66	1.85	2.03	2.19	2.34	0.99	1.11	1.24	1.36	1.47	1.57
HF	4-1/2	3.27	3.78	4.22	4.72	5.17	5.59	2.63	2.95	3.29	3.61	3.9	4.17	1.76	1.97	2.2	2.41	2.61	2.79
HF	6-1/2	4.55	5.25	5.87	6.57	7.19	7.77	3.66	4.1	4.58	5.02	5.42	5.79	2.45	2.74	3.07	3.36	3.63	3.88
HF	8	5.78	6.67	7.46	8.34	9.13	9.87	4.65	5.2	5.82	6.37	6.88	7.36	3.11	3.48	3.89	4.26	4.61	4.92
HF	12	8.55	9.88	11.04	12.35	13.53	14.61	6.89	7.7	8.61	9.43	10.19	10.89	4.61	5.16	5.76	6.31	6.82	7.29
HF	16	11.22	12.96	14.49	16.2	17.74	19.16	9.04	10.1	11.29	12.37	13.36	14.29	6.05	6.76	7.56	8.28	8.95	9.56

Refrigerant liquid temperature correction factors

	Refrigerant liquid temperature °F															
	0	10	20	30	40	50	60	70	80	90	100	110	120	130	140	
R-290	1.70	1.63	1.56	1.49	1.42	1.36	1.29	1.22	1.14	1.07	1.00	0.93	0.85	0.78	0.70	

NOTE: These factors include corrections for liquid refrigerant density and net refrigeration effect, and are based on an average evaporator temperature of 0°F with a maximum 7°F Change in Superheat. However, they may be used for any evaporator temperature from -40°F to +40°F since the variation in the actual factors across this range is insignificant.

R-404A/R-507 balanced ported valves (tons) NXT-R / B / HF / TFE / TRAE / T Series

Valve type	Nom. rating	Evaporator temperature																	
		50°F						40°F						20°F					
		Pressure drop across valve (psi)						Pressure drop across valve (psi)						Pressure drop across valve (psi)					
		60	80	100	125	150	175	60	80	100	125	150	175	60	80	100	125	150	175
NXT-R	1/8	0.08	0.1	0.11	0.12	0.13	0.14	0.08	0.09	0.11	0.12	0.13	0.14	0.08	0.09	0.1	0.11	0.12	0.13
NXT-R	1/4	0.22	0.25	0.28	0.31	0.34	0.37	0.21	0.25	0.27	0.31	0.34	0.36	0.2	0.23	0.26	0.29	0.32	0.35
NXT-R	1/2	0.36	0.42	0.47	0.52	0.57	0.62	0.35	0.41	0.46	0.51	0.56	0.61	0.34	0.39	0.43	0.49	0.53	0.58
NXT-R	3/4	0.49	0.56	0.63	0.7	0.77	0.83	0.47	0.55	0.61	0.69	0.75	0.81	0.45	0.52	0.58	0.65	0.71	0.77
NXT-R	1	0.87	1.01	1.12	1.26	1.38	1.49	0.85	0.98	1.1	1.23	1.35	1.45	0.81	0.93	1.04	1.17	1.28	1.38
NXT-R	1 1/4	1.16	1.34	1.5	1.68	1.84	1.98	1.13	1.31	1.46	1.64	1.79	1.94	1.08	1.24	1.39	1.56	1.7	1.84
NXT-R	1 1/2	1.55	1.79	2	2.23	2.44	2.64	1.51	1.74	1.95	2.18	2.39	2.58	1.44	1.66	1.85	2.07	2.27	2.45
NXT-R	2	1.73	2	2.23	2.5	2.74	2.95	1.69	1.95	2.18	2.44	2.67	2.89	1.61	1.85	2.07	2.32	2.54	2.74
NXT-R	2 1/2	2.25	2.6	2.91	3.25	3.57	3.85	2.2	2.54	2.85	3.18	3.48	3.76	2.09	2.42	2.7	3.02	3.31	3.58
NXT-R	3	2.49	2.88	3.22	3.6	3.94	4.26	2.44	2.82	3.15	3.52	3.86	4.16	2.32	2.67	2.99	3.34	3.66	3.96
NXT-R	3 1/2	3.05	3.52	3.93	4.4	4.82	5.2	2.98	3.44	3.85	4.3	4.71	5.09	2.83	3.27	3.65	4.08	4.47	4.83
NXT-R	4	3.57	4.12	4.61	5.16	5.65	6.1	3.49	4.03	4.51	5.04	5.52	5.96	3.32	3.83	4.28	4.79	5.24	5.66
NXT-R	5 1/2	4.38	5.05	5.65	6.32	6.92	7.47	4.28	4.94	5.52	6.17	6.76	7.3	4.06	4.69	5.25	5.86	6.42	6.94
BA/BN	1/4	0.29	0.33	0.37	0.42	0.46	0.5	0.28	0.32	0.36	0.4	0.44	0.48	0.27	0.31	0.35	0.39	0.43	0.46
BA/BN	1/2	0.55	0.64	0.71	0.79	0.87	0.94	0.53	0.61	0.68	0.76	0.84	0.91	0.51	0.59	0.66	0.74	0.81	0.87
BA/BN	1	0.85	0.98	1.1	1.23	1.34	1.45	0.83	0.96	1.07	1.2	1.31	1.42	0.79	0.91	1.02	1.14	1.25	1.35
BA/BN	1-1/4	1.14	1.32	1.47	1.65	1.8	1.95	1.11	1.28	1.43	1.6	1.76	1.9	1.06	1.22	1.37	1.53	1.68	1.81
BA/BN	1-1/2	1.44	1.66	1.86	2.08	2.28	2.46	1.41	1.63	1.82	2.04	2.23	2.41	1.34	1.55	1.73	1.93	2.12	2.29
BA/BN	2	1.74	2.01	2.25	2.51	2.75	2.97	1.7	1.96	2.19	2.45	2.69	2.9	1.62	1.87	2.09	2.34	2.56	2.77
BA/BN	2-1/2	2.26	2.61	2.92	3.26	3.57	3.86	2.2	2.54	2.84	3.18	3.48	3.76	2.09	2.41	2.7	3.02	3.3	3.57
BA/BN	3	2.85	3.29	3.68	4.11	4.51	4.87	2.79	3.22	3.6	4.03	4.41	4.76	2.65	3.06	3.42	3.82	4.19	4.53
BA/BN	4	3.55	4.1	4.58	5.12	5.61	6.06	3.47	4.01	4.48	5.01	5.49	5.93	3.29	3.8	4.25	4.75	5.2	5.62
HF	1/8	0.16	0.18	0.21	0.23	0.25	0.27	0.16	0.18	0.21	0.23	0.25	0.27	0.15	0.17	0.19	0.22	0.24	0.26
HF	1/4	0.31	0.36	0.4	0.45	0.49	0.53	0.3	0.35	0.39	0.43	0.47	0.51	0.28	0.32	0.36	0.4	0.44	0.48
HF	1/2	0.55	0.64	0.71	0.79	0.87	0.94	0.53	0.61	0.68	0.76	0.84	0.91	0.51	0.59	0.66	0.74	0.81	0.87
HF	1	0.83	0.96	1.07	1.2	1.31	1.42	0.82	0.95	1.06	1.18	1.3	1.4	0.77	0.89	0.99	1.11	1.22	1.32
HF	1-1/4	1.12	1.29	1.45	1.62	1.77	1.91	1.1	1.27	1.42	1.59	1.74	1.88	1.04	1.2	1.34	1.5	1.64	1.78
HF	1-1/2	1.44	1.66	1.86	2.08	2.28	2.46	1.41	1.63	1.82	2.04	2.23	2.41	1.34	1.55	1.73	1.93	2.12	2.29
HF	2	1.9	2.19	2.45	2.74	3	3.24	1.86	2.15	2.4	2.68	2.94	3.18	1.76	2.03	2.27	2.54	2.78	3.01
HF	3-1/2	3.38	3.9	4.36	4.88	5.34	5.77	3.3	3.81	4.26	4.76	5.22	5.64	3.13	3.61	4.04	4.52	4.95	5.35
HF	5	4.7	5.43	6.07	6.78	7.43	8.03	4.59	5.3	5.93	6.63	7.26	7.84	4.36	5.03	5.63	6.29	6.89	7.45
HF	7	5.95	6.87	7.68	8.59	9.41	10.16	5.81	6.71	7.5	8.39	9.19	9.92	5.52	6.37	7.13	7.97	8.73	9.43
HF	10	8.83	10.2	11.4	12.75	13.96	15.08	8.62	9.95	11.13	12.44	13.63	14.72	8.19	9.46	10.57	11.82	12.95	13.99
HF	13	11.62	13.42	15	16.77	18.37	19.84	11.35	13.11	14.65	16.38	17.95	19.38	10.78	12.45	13.92	15.56	17.04	18.41
TFE	5	4.62	5.33	5.96	6.67	7.3	7.89	4.51	5.21	5.82	6.51	7.13	7.7	4.28	4.94	5.53	6.18	6.77	7.31
TFE	7	6.32	7.3	8.16	9.12	9.99	10.79	6.17	7.12	7.97	8.91	9.76	10.54	5.86	6.77	7.57	8.46	9.27	10.01
TFE	9	7.84	9.05	10.12	11.32	12.4	13.39	7.66	8.85	9.89	11.06	12.11	13.08	7.28	8.41	9.4	10.51	11.51	12.43
TFE	14	11.98	13.83	15.47	17.29	18.94	20.46	11.7	13.51	15.1	16.89	18.5	19.98	11.11	12.83	14.34	16.04	17.57	18.97
TRAE+	8	6.79	7.84	8.77	9.8	10.74	11.6	6.63	7.66	8.56	9.57	10.48	11.32	6.3	7.27	8.13	9.09	9.96	10.76
TRAE+	12	9.9	11.43	12.78	14.29	15.65	16.91	9.67	11.17	12.48	13.96	15.29	16.51	9.19	10.61	11.86	13.26	14.53	15.69
TRAE+	14	11.05	12.76	14.27	15.95	17.47	18.87	10.79	12.46	13.93	15.57	17.06	18.43	10.25	11.84	13.23	14.79	16.21	17.51
TRAE+	20	16.75	19.34	21.62	24.18	26.48	28.61	16.36	18.89	21.12	23.61	25.87	27.94	15.54	17.94	20.06	22.43	24.57	26.54
TRAE+	30	23.02	26.58	29.72	33.23	36.4	39.31	22.49	25.97	29.03	32.46	35.56	38.41	21.36	24.66	27.58	30.83	33.77	36.48
TRAE	35	31.08	35.89	40.12	44.86	49.14	53.08	30.36	35.06	39.19	43.82	48	51.85	28.84	33.3	37.23	41.63	45.6	49.25
TRAE	40	33.9	39.14	43.76	48.93	53.6	57.9	33.11	38.23	42.74	47.79	52.35	56.55	31.45	36.32	40.6	45.39	49.73	53.71
TRAE	50	40.34	46.58	52.08	58.23	63.78	68.89	39.41	45.51	50.88	56.88	62.31	67.31	37.44	43.23	48.33	54.04	59.2	63.94
TJR	9	8.46	9.77	10.92	12.21	13.38	14.45	8.26	9.54	10.66	11.92	13.06	14.11	7.85	9.06	10.13	11.33	12.41	13.41
TJR	12	10.13	11.7	13.08	14.62	16.02	17.3	9.89	11.42	12.77	14.27	15.64	16.89	9.4	10.85	12.14	13.57	14.86	16.05
TER	14	12.66	14.62	16.34	18.27	20.02	21.62	12.37	14.28	15.97	17.85	19.56	21.13	11.75	13.57	15.17	16.96	18.58	20.07
TER	16	14.96	17.27	19.31	21.59	23.65	25.55	14.62	16.88	18.87	21.1	23.12	24.97	13.88	16.03	17.92	20.03	21.95	23.7
TER	21	20.14	23.26	26	29.07	31.84	34.4	19.68	22.72	25.41	28.41	31.12	33.61	18.69	21.58	24.13	26.98	29.55	31.92
TER	27	25.9	29.91	33.44	37.38	40.95	44.23	25.3	29.21	32.66	36.52	40	43.21	24.03	27.75	31.02	34.68	37.99	41.04
TIR	37	31.65	36.55	40.86	45.68	50.04	54.05	30.92	35.7	39.92	44.63	48.89	52.81	29.37	33.91	37.92	42.39	46.44	50.16
THR	48	40.29	46.52	52.01	58.15	63.7	68.81	39.35	45.44	50.8	56.8	62.22	67.2	37.38	43.16	48.26	53.95	59.1	63.84
THR	60	48.92	56.49	63.16	70.61	77.35	83.55	47.78	55.17	61.68	68.96	75.55	81.6	45.39	52.41	58.6	65.51	71.77	77.52
TMR	60	57.55	66.45	74.3	83.07	90.99	98.29	56.22	64.92	72.58	81.15	88.89	96.01	53.4	61.66	68.94	77.08	84.43	91.2

Note: Standard capacity is rated at 100F liquid inlet and 40F evaporator temperature; with 100 Psi pressure drop across the TXV per ARI 750-2001.

R-404A / R-507 balanced ported valves (tons) B / HF / TFE / TRAE / T Series (cont'd)

Valve type	Nom. rating	Evaporator temperature																	
		0°F						-20°F						-40°F					
		Pressure drop across valve (psi)						Pressure drop across valve (psi)						Pressure drop across valve (psi)					
		60	80	100	125	150	175	80	100	125	150	175	200	80	100	125	150	175	200
NXT-R	1/8	0.07	0.08	0.09	0.11	0.12	0.13	0.06	0.07	0.08	0.09	0.09	0.1	0.04	0.05	0.05	0.06	0.06	0.06
NXT-R	1/4	0.19	0.22	0.25	0.28	0.3	0.33	0.16	0.18	0.21	0.23	0.24	0.26	0.11	0.12	0.13	0.15	0.16	0.17
NXT-R	1/2	0.32	0.37	0.41	0.46	0.5	0.54	0.27	0.31	0.34	0.38	0.41	0.43	0.18	0.2	0.22	0.24	0.26	0.28
NXT-R	3/4	0.43	0.49	0.55	0.61	0.67	0.73	0.37	0.41	0.46	0.5	0.54	0.58	0.24	0.27	0.3	0.33	0.35	0.38
NXT-R	1	0.76	0.88	0.98	1.1	1.21	1.3	0.66	0.74	0.82	0.9	0.98	1.04	0.43	0.48	0.53	0.58	0.63	0.67
NXT-R	1 1/4	1.02	1.17	1.31	1.47	1.61	1.74	0.88	0.98	1.1	1.2	1.3	1.39	0.57	0.64	0.71	0.78	0.84	0.9
NXT-R	1 1/2	1.35	1.56	1.75	1.95	2.14	2.31	1.17	1.31	1.46	1.6	1.73	1.85	0.76	0.85	0.95	1.04	1.12	1.2
NXT-R	2	1.52	1.75	1.96	2.19	2.4	2.59	1.31	1.46	1.64	1.79	1.94	2.07	0.85	0.95	1.06	1.16	1.25	1.34
NXT-R	2 1/2	1.98	2.28	2.55	2.85	3.12	3.37	1.71	1.91	2.13	2.34	2.53	2.7	1.1	1.23	1.38	1.51	1.63	1.75
NXT-R	3	2.19	2.52	2.82	3.15	3.46	3.73	1.89	2.11	2.36	2.59	2.79	2.99	1.22	1.37	1.53	1.67	1.81	1.93
NXT-R	3 1/2	2.67	3.08	3.45	3.85	4.22	4.56	2.31	2.58	2.88	3.16	3.41	3.65	1.49	1.67	1.86	2.04	2.21	2.36
NXT-R	4	3.13	3.61	4.04	4.52	4.95	5.34	2.7	3.02	3.38	3.7	4	4.28	1.75	1.95	2.19	2.39	2.59	2.76
NXT-R	5 1/2	3.83	4.43	4.95	5.53	6.06	6.55	3.31	3.7	4.14	4.54	4.9	5.24	2.14	2.39	2.68	2.93	3.17	3.39
BA/BN	1/4	0.24	0.28	0.31	0.35	0.38	0.41	0.19	0.21	0.24	0.26	0.28	0.3	0.12	0.13	0.15	0.16	0.18	0.19
BA/BN	1/2	0.45	0.52	0.58	0.65	0.71	0.77	0.36	0.4	0.45	0.49	0.53	0.57	0.23	0.26	0.29	0.31	0.34	0.36
BA/BN	1	0.71	0.82	0.92	1.02	1.12	1.21	0.55	0.61	0.69	0.75	0.81	0.87	0.36	0.4	0.45	0.49	0.53	0.57
BA/BN	1-1/4	0.94	1.09	1.21	1.36	1.49	1.61	0.74	0.83	0.93	1.01	1.09	1.17	0.48	0.54	0.6	0.66	0.71	0.76
BA/BN	1-1/2	1.19	1.37	1.54	1.72	1.88	2.03	0.93	1.04	1.16	1.27	1.38	1.47	0.61	0.68	0.76	0.84	0.9	0.96
BA/BN	2	1.44	1.66	1.86	2.08	2.28	2.46	1.13	1.26	1.41	1.55	1.67	1.79	0.74	0.83	0.93	1.01	1.09	1.17
BA/BN	2-1/2	1.87	2.16	2.41	2.7	2.96	3.19	1.47	1.64	1.84	2.01	2.17	2.32	0.96	1.07	1.2	1.31	1.42	1.52
BA/BN	3	2.36	2.73	3.05	3.41	3.73	4.03	1.85	2.07	2.31	2.53	2.74	2.93	1.21	1.35	1.51	1.66	1.79	1.91
BA/BN	4	2.94	3.39	3.8	4.24	4.65	5.02	2.31	2.58	2.89	3.16	3.42	3.65	1.51	1.69	1.89	2.07	2.23	2.39
HF	1/8	0.13	0.15	0.17	0.19	0.21	0.22	0.1	0.11	0.13	0.14	0.15	0.16	0.07	0.08	0.09	0.1	0.1	0.11
HF	1/4	0.25	0.29	0.32	0.36	0.4	0.43	0.2	0.22	0.25	0.27	0.3	0.32	0.13	0.15	0.16	0.18	0.19	0.21
HF	1/2	0.45	0.52	0.58	0.65	0.71	0.77	0.36	0.4	0.45	0.49	0.53	0.57	0.23	0.26	0.29	0.31	0.34	0.36
HF	1	0.69	0.8	0.89	1	1.09	1.18	0.54	0.6	0.68	0.74	0.8	0.85	0.35	0.39	0.44	0.48	0.52	0.55
HF	1-1/4	0.93	1.07	1.2	1.34	1.47	1.59	0.73	0.82	0.91	1	1.08	1.15	0.48	0.54	0.6	0.66	0.71	0.76
HF	1-1/2	1.19	1.37	1.54	1.72	1.88	2.03	0.93	1.04	1.16	1.27	1.38	1.47	0.61	0.68	0.76	0.84	0.9	0.96
HF	2	1.57	1.81	2.03	2.27	2.48	2.68	1.23	1.38	1.54	1.68	1.82	1.94	0.81	0.91	1.01	1.11	1.2	1.28
HF	3-1/2	2.8	3.23	3.61	4.04	4.43	4.78	2.19	2.45	2.74	3	3.24	3.46	1.43	1.6	1.79	1.96	2.11	2.26
HF	5	3.89	4.49	5.02	5.61	6.15	6.64	3.05	3.41	3.81	4.18	4.51	4.82	2	2.24	2.5	2.74	2.96	3.16
HF	7	4.93	5.69	6.36	7.12	7.8	8.42	3.87	4.33	4.84	5.3	5.72	6.12	2.53	2.83	3.16	3.46	3.74	4
HF	10	7.31	8.44	9.44	10.55	11.56	12.48	5.73	6.41	7.16	7.85	8.47	9.06	3.75	4.19	4.69	5.13	5.55	5.93
HF	13	9.62	11.11	12.42	13.89	15.21	16.43	7.55	8.44	9.44	10.34	11.17	11.94	4.93	5.51	6.16	6.75	7.29	7.8
TFE	5	3.82	4.41	4.93	5.51	6.04	6.52	3	3.35	3.75	4.11	4.44	4.74	1.96	2.19	2.45	2.68	2.9	3.1
TFE	7	5.23	6.04	6.75	7.55	8.27	8.93	4.1	4.58	5.13	5.61	6.06	6.48	2.68	3	3.35	3.67	3.96	4.24
TFE	9	6.5	7.51	8.39	9.38	10.28	11.1	5.1	5.7	6.38	6.98	7.54	8.06	3.33	3.72	4.16	4.56	4.93	5.27
TFE	14	9.92	11.45	12.81	14.32	15.68	16.94	7.78	8.7	9.73	10.65	11.51	12.3	5.08	5.68	6.35	6.96	7.51	8.03

R-404A / R-507 balanced ported valves (tons) B / HF / TFE / TRAE / T Series (cont'd)

Valve type	Nom. rating	Evaporator temperature																	
		0°F						-20°F						-40°F					
		Pressure drop across valve (psi)						Pressure drop across valve (psi)						Pressure drop across valve (psi)					
		60	80	100	125	150	175	80	100	125	150	175	200	80	100	125	150	175	200
TRAE+	8	5.62	6.49	7.26	8.11	8.89	9.6	4.41	4.93	5.51	6.04	6.52	6.97	2.88	3.22	3.6	3.94	4.26	4.55
TRAE+	12	8.2	9.47	10.59	11.84	12.97	14	6.43	7.19	8.04	8.8	9.51	10.17	4.2	4.7	5.25	5.75	6.21	6.64
TRAE+	14	9.15	10.57	11.81	13.21	14.47	15.63	7.18	8.03	8.98	9.83	10.62	11.35	4.69	5.24	5.86	6.42	6.94	7.42
TRAE+	20	13.87	16.02	17.91	20.02	21.93	23.69	10.88	12.16	13.6	14.9	16.09	17.2	7.11	7.95	8.89	9.74	10.52	11.24
TRAE+	30	19.06	22.01	24.61	27.51	30.14	32.55	14.95	16.71	18.69	20.47	22.11	23.64	9.77	10.92	12.21	13.38	14.45	15.45
TRAE	35	25.73	29.71	33.22	37.14	40.68	43.94	20.19	22.57	25.24	27.65	29.86	31.92	13.19	14.75	16.49	18.06	19.51	20.86
TRAE	40	28.07	32.41	36.24	40.52	44.38	47.94	22.02	24.62	27.53	30.15	32.57	34.82	14.39	16.09	17.99	19.7	21.28	22.75
TRAE	50	33.41	38.58	43.13	48.22	52.83	57.06	26.2	29.29	32.75	35.88	38.75	41.43	17.13	19.15	21.41	23.46	25.34	27.08
TJR	9	7.01	8.09	9.05	10.12	11.08	11.97	5.5	6.15	6.88	7.53	8.13	8.7	3.59	4.01	4.49	4.92	5.31	5.68
TJR	12	8.39	9.69	10.83	12.11	13.27	14.33	6.58	7.36	8.23	9.01	9.73	10.4	4.3	4.81	5.38	5.89	6.36	6.8
TER	14	10.48	12.1	13.53	15.13	16.57	17.9	8.22	9.19	10.28	11.26	12.16	13	5.3	5.93	6.63	7.26	7.84	8.38
TER	16	12.39	14.31	16	17.88	19.59	21.16	9.72	10.87	12.15	13.31	14.38	15.37	6.35	7.1	7.94	8.7	9.39	10.04
TER	21	16.68	19.26	21.53	24.08	26.37	28.49	13.08	14.62	16.35	17.91	19.35	20.68	8.55	9.56	10.69	11.71	12.65	13.52
TER	27	21.45	24.77	27.69	30.96	33.92	36.63	16.82	18.81	21.03	23.03	24.88	26.59	11	12.3	13.75	15.06	16.27	17.39
TIR	37	26.21	30.26	33.84	37.83	41.44	44.76	20.56	22.99	25.7	28.15	30.41	32.51	13.44	15.03	16.8	18.4	19.88	21.25
THR	48	33.36	38.52	43.07	48.15	52.75	56.97	26.17	29.26	32.71	35.83	38.71	41.38	17.1	19.12	21.38	23.42	25.29	27.04
THR	60	40.51	46.78	52.3	58.47	64.05	69.18	31.77	35.52	39.71	43.5	46.99	50.23	20.77	23.22	25.96	28.44	30.72	32.84
TMR	60	47.66	55.03	61.53	68.79	75.36	81.39	37.38	41.79	46.73	51.18	55.29	59.1	24.43	27.31	30.54	33.45	36.13	38.63

Refrigerant liquid temperature correction factors

	Refrigerant liquid temperature °F														
	0	10	20	30	40	50	60	70	80	90	100	110	120	130	140
R-404A/R-507	2.00	1.90	1.80	1.70	1.60	1.50	1.40	1.30	1.20	1.10	1.00	0.90	0.80	0.70	0.50

NOTE: These factors include corrections for liquid refrigerant density and net refrigeration effect, and are based on an average evaporator temperature of 0°F with a maximum 7°F Change in Superheat. However, they may be used for any evaporator temperature from -40°F to +40°F since the variation in the actual factors across this range is insignificant.

R-407A balance ported valves (tons) NXT-R, B and H Series

Valve type	Nom. rating	Evaporator temperature																	
		50°F						40°F						20°F					
		Pressure drop across valve (psi)						Pressure drop across valve (psi)						Pressure drop across valve (psi)					
		60	80	100	125	150	175	60	80	100	125	150	175	60	80	100	125	150	175
NXT-R	1/10	0.05	0.05	0.06	0.07	0.07	0.08	0.05	0.05	0.06	0.07	0.07	0.08	0.04	0.05	0.06	0.06	0.07	0.08
NXT-R	1/5	0.12	0.14	0.15	0.17	0.19	0.20	0.12	0.13	0.15	0.17	0.18	0.20	0.11	0.13	0.14	0.16	0.18	0.19
NXT-R	1/4	0.31	0.35	0.40	0.44	0.48	0.52	0.30	0.35	0.39	0.43	0.48	0.51	0.29	0.33	0.37	0.42	0.46	0.49
NXT-R	1/2	0.51	0.59	0.66	0.74	0.81	0.87	0.50	0.58	0.65	0.72	0.79	0.86	0.48	0.56	0.62	0.70	0.76	0.82
NXT-R	1	0.68	0.79	0.88	0.99	1.08	1.17	0.67	0.78	0.87	0.97	1.06	1.15	0.65	0.75	0.83	0.93	1.02	1.10
NXT-R	1 1/2	1.22	1.41	1.58	1.77	1.94	2.09	1.20	1.39	1.55	1.74	1.90	2.06	1.16	1.34	1.50	1.67	1.83	1.98
NXT-R	2	1.63	1.89	2.11	2.36	2.58	2.79	1.61	1.85	2.07	2.32	2.54	2.74	1.54	1.78	1.99	2.23	2.44	2.64
NXT-R	2 1/2	2.17	2.51	2.81	3.14	3.44	3.71	2.14	2.47	2.76	3.09	3.38	3.65	2.06	2.38	2.66	2.97	3.25	3.51
NXT-R	3	2.43	2.81	3.14	3.51	3.85	4.16	2.39	2.76	3.09	3.45	3.78	4.09	2.30	2.66	2.97	3.32	3.64	3.93
NXT-R	4	3.17	3.66	4.09	4.58	5.01	5.42	3.12	3.60	4.02	4.50	4.93	5.32	3.00	3.46	3.87	4.33	4.74	5.12
NXT-R	5	3.96	4.58	5.12	5.72	6.27	6.77	3.90	4.50	5.03	5.62	6.16	6.66	3.75	4.33	4.84	5.41	5.93	6.41
NXT-R	5 1/2	4.29	4.95	5.53	6.19	6.78	7.32	4.21	4.87	5.44	6.08	6.66	7.20	4.06	4.68	5.24	5.85	6.41	6.93
NXT-R	8	6.15	7.11	7.95	8.88	9.73	10.51	6.05	6.99	7.81	8.73	9.57	10.33	5.82	6.72	7.52	8.41	9.21	9.95
BA/BN	1/2	0.39	0.45	0.51	0.57	0.62	0.67	0.39	0.45	0.50	0.56	0.61	0.66	0.37	0.43	0.48	0.54	0.59	0.63
BA/BN	1	0.75	0.86	0.96	1.08	1.18	1.27	0.73	0.85	0.95	1.06	1.16	1.25	0.71	0.81	0.91	1.02	1.12	1.21
BA/BN	1-1/2	1.16	1.34	1.50	1.68	1.84	1.98	1.14	1.32	1.47	1.65	1.81	1.95	1.10	1.27	1.42	1.59	1.74	1.88
BA/BN	2	1.55	1.79	2.01	2.24	2.46	2.65	1.53	1.76	1.97	2.21	2.42	2.61	1.47	1.70	1.90	2.12	2.33	2.51
BA/BN	2-1/2	1.96	2.27	2.53	2.83	3.10	3.35	1.93	2.23	2.49	2.78	3.05	3.29	1.86	2.14	2.40	2.68	2.94	3.17
BA/BN	3	2.38	2.75	3.07	3.43	3.76	4.06	2.34	2.70	3.02	3.37	3.70	3.99	2.25	2.60	2.91	3.25	3.56	3.84
BA/BN	4	3.08	3.55	3.97	4.44	4.87	5.26	3.02	3.49	3.91	4.37	4.78	5.17	2.91	3.36	3.76	4.20	4.60	4.97
BA/BN	5	3.90	4.51	5.04	5.63	6.17	6.66	3.84	4.43	4.95	5.54	6.06	6.55	3.69	4.26	4.77	5.33	5.84	6.30
BA/BN	6	4.84	5.59	6.25	6.99	7.66	8.27	4.76	5.50	6.15	6.87	7.53	8.13	4.58	5.29	5.92	6.61	7.25	7.83
HF	1/4	0.22	0.25	0.28	0.32	0.35	0.38	0.22	0.25	0.28	0.31	0.34	0.37	0.21	0.24	0.27	0.30	0.33	0.36
HF	1/2	0.42	0.48	0.54	0.60	0.66	0.71	0.41	0.47	0.53	0.59	0.65	0.70	0.39	0.45	0.51	0.57	0.62	0.67
HF	1	0.75	0.86	0.96	1.08	1.18	1.27	0.73	0.85	0.95	1.06	1.16	1.25	0.71	0.81	0.91	1.02	1.12	1.21
HF	1-1/2	1.14	1.31	1.47	1.64	1.80	1.94	1.12	1.29	1.44	1.62	1.77	1.91	1.08	1.24	1.39	1.55	1.70	1.84
HF	2	1.54	1.78	1.99	2.22	2.43	2.63	1.51	1.75	1.95	2.18	2.39	2.58	1.46	1.68	1.88	2.10	2.30	2.49
HF	2-1/2	1.97	2.28	2.54	2.84	3.12	3.37	1.94	2.24	2.50	2.80	3.06	3.31	1.86	2.15	2.41	2.69	2.95	3.18
HF	3	2.60	3.00	3.35	3.75	4.11	4.44	2.55	2.95	3.30	3.69	4.04	4.36	2.46	2.84	3.17	3.55	3.89	4.20
HF	6	4.62	5.34	5.97	6.67	7.31	7.90	4.55	5.25	5.87	6.56	7.19	7.76	4.37	5.05	5.65	6.31	6.92	7.47
HF	8	6.43	7.42	8.30	9.28	10.17	10.98	6.32	7.30	8.16	9.12	9.99	10.79	6.08	7.02	7.85	8.78	9.62	10.39
HF	10	8.16	9.43	10.54	11.78	12.91	13.94	8.03	9.27	10.36	11.58	12.69	13.71	7.72	8.92	9.97	11.15	12.21	13.19
HF	15	12.09	13.96	15.61	17.45	19.12	20.65	11.88	13.72	15.34	17.15	18.79	20.30	11.44	13.21	14.77	16.51	18.09	19.54
HF	20	15.86	18.31	20.47	22.89	25.07	27.08	15.59	18.00	20.12	22.50	24.65	26.62	15.00	17.32	19.37	21.66	23.72	25.62

NOTE: Standard capacity is rated at 100°F liquid inlet and 40°F evaporator temperature; with 100 PSI pressure drop across the TXV.

R-407A balance ported valves (tons) NXT-R, B and H Series

Valve type	Nom. rating	Evaporator temperature																	
		0°F						-20°F						-40°F					
		Pressure drop across valve (psi)						Pressure drop across valve (psi)						Pressure drop across valve (psi)					
		60	80	100	125	150	175	80	100	125	150	175	200	80	100	125	150	175	200
NXT-R	1/10	0.04	0.05	0.05	0.06	0.06	0.07	0.03	0.03	0.04	0.04	0.05	0.05	0.02	0.02	0.02	0.03	0.03	0.03
NXT-R	1/5	0.1	0.12	0.13	0.15	0.16	0.17	0.08	0.09	0.1	0.11	0.12	0.12	0.05	0.06	0.06	0.07	0.07	0.08
NXT-R	1/4	0.26	0.31	0.34	0.38	0.42	0.45	0.2	0.23	0.25	0.28	0.3	0.32	0.13	0.14	0.16	0.18	0.19	0.2
NXT-R	1/2	0.44	0.51	0.57	0.64	0.7	0.75	0.34	0.38	0.42	0.46	0.5	0.54	0.21	0.24	0.27	0.29	0.32	0.34
NXT-R	1	0.59	0.68	0.76	0.85	0.93	1.01	0.45	0.51	0.57	0.62	0.67	0.72	0.29	0.32	0.36	0.39	0.42	0.45
NXT-R	1 1/2	1.06	1.22	1.37	1.53	1.67	1.81	0.81	0.91	1.02	1.11	1.2	1.29	0.51	0.58	0.64	0.7	0.76	0.81
NXT-R	2	1.41	1.63	1.82	2.04	2.23	2.41	1.08	1.21	1.36	1.49	1.6	1.72	0.69	0.77	0.86	0.94	1.01	1.08
NXT-R	2 1/2	1.88	2.17	2.43	2.72	2.97	3.21	1.44	1.62	1.81	1.98	2.14	2.28	0.91	1.02	1.14	1.25	1.35	1.44
NXT-R	3	2.11	2.43	2.72	3.04	3.33	3.6	1.62	1.81	2.02	2.21	2.39	2.56	1.02	1.14	1.28	1.4	1.51	1.62
NXT-R	4	2.74	3.17	3.54	3.96	4.34	4.69	2.11	2.36	2.63	2.89	3.12	3.33	1.33	1.49	1.67	1.82	1.97	2.11
NXT-R	5	3.43	3.96	4.43	4.95	5.42	5.86	2.63	2.94	3.29	3.61	3.9	4.16	1.67	1.86	2.08	2.28	2.46	2.63
NXT-R	5 1/2	3.71	4.28	4.79	5.35	5.86	6.33	2.85	3.18	3.56	3.9	4.21	4.5	1.8	2.01	2.25	2.47	2.66	2.85
NXT-R	8	5.32	6.15	6.87	7.68	8.42	9.09	4.09	4.57	5.11	5.6	6.05	6.47	2.59	2.89	3.23	3.54	3.83	4.09
BA/BN	1/2	0.34	0.39	0.44	0.49	0.54	0.58	0.26	0.29	0.33	0.36	0.39	0.41	0.17	0.19	0.21	0.23	0.25	0.27
BA/BN	1	0.65	0.74	0.83	0.93	1.02	1.1	0.5	0.55	0.62	0.68	0.73	0.78	0.32	0.36	0.4	0.44	0.47	0.51
BA/BN	1-1/2	1.01	1.16	1.3	1.45	1.59	1.72	0.77	0.86	0.96	1.06	1.14	1.22	0.5	0.56	0.63	0.68	0.74	0.79
BA/BN	2	1.34	1.55	1.74	1.94	2.13	2.3	1.03	1.15	1.29	1.41	1.53	1.63	0.67	0.75	0.84	0.92	0.99	1.06
BA/BN	2-1/2	1.7	1.96	2.19	2.45	2.68	2.9	1.3	1.46	1.63	1.79	1.93	2.06	0.84	0.94	1.06	1.16	1.25	1.34
BA/BN	3	2.06	2.38	2.66	2.97	3.25	3.51	1.58	1.77	1.98	2.16	2.34	2.5	1.02	1.14	1.28	1.4	1.51	1.62
BA/BN	4	2.66	3.07	3.44	3.84	4.21	4.55	2.04	2.29	2.56	2.8	3.02	3.23	1.32	1.48	1.66	1.81	1.96	2.09
BA/BN	5	3.37	3.9	4.36	4.87	5.34	5.76	2.59	2.9	3.24	3.55	3.83	4.1	1.68	1.88	2.1	2.3	2.48	2.66
BA/BN	6	4.19	4.84	5.41	6.05	6.62	7.16	3.22	3.6	4.02	4.41	4.76	5.09	2.08	2.33	2.61	2.85	3.08	3.3
HF	1/4	0.19	0.22	0.25	0.27	0.3	0.32	0.15	0.16	0.18	0.2	0.22	0.23	0.09	0.1	0.12	0.13	0.14	0.15
HF	1/2	0.36	0.42	0.46	0.52	0.57	0.61	0.28	0.31	0.35	0.38	0.41	0.44	0.17	0.2	0.22	0.24	0.26	0.28
HF	1	0.65	0.74	0.83	0.93	1.02	1.1	0.5	0.55	0.62	0.68	0.73	0.78	0.31	0.35	0.39	0.43	0.46	0.5
HF	1-1/2	0.98	1.14	1.27	1.42	1.56	1.68	0.76	0.85	0.95	1.04	1.12	1.2	0.48	0.53	0.6	0.65	0.71	0.76
HF	2	1.33	1.54	1.72	1.92	2.1	2.27	1.02	1.14	1.28	1.4	1.51	1.62	0.65	0.72	0.81	0.89	0.96	1.02
HF	2-1/2	1.7	1.97	2.2	2.46	2.7	2.91	1.31	1.46	1.64	1.79	1.94	2.07	0.83	0.93	1.03	1.13	1.22	1.31
HF	3-1/2	2.25	2.6	2.9	3.24	3.55	3.84	1.73	1.93	2.16	2.36	2.55	2.73	1.09	1.22	1.36	1.5	1.61	1.73
HF	6	4	4.62	5.16	5.77	6.32	6.83	3.07	3.43	3.84	4.21	4.54	4.86	1.94	2.17	2.43	2.66	2.87	3.07
HF	8-1/2	5.56	6.42	7.18	8.03	8.79	9.5	4.27	4.78	5.34	5.85	6.32	6.75	2.7	3.02	3.38	3.7	4	4.27
HF	10-1/2	7.06	8.15	9.12	10.19	11.17	12.06	5.42	6.06	6.78	7.43	8.02	8.58	3.43	3.84	4.29	4.7	5.07	5.42
HF	16	10.46	12.08	13.5	15.09	16.54	17.86	8.03	8.98	10.04	11	11.88	12.7	5.08	5.68	6.35	6.96	7.51	8.03
HF	10	13.72	15.84	17.71	19.8	21.69	23.43	10.54	11.78	13.17	14.43	15.58	16.66	6.66	7.45	8.33	9.12	9.86	10.54

Refrigerant liquid temperature correction factors

	Refrigerant liquid temperature °F															
	0	10	20	30	40	50	60	70	80	90	100	110	120	130	140	
R-407A	1.78	1.70	1.63	1.55	1.47	1.40	1.32	1.24	1.16	1.08	1.00	0.92	0.83	0.75	0.66	

NOTE: These factors include corrections for liquid refrigerant density and net refrigeration effect, and are based on an average evaporator temperature of 0°F with a maximum 7°F Change in Superheat. However, they may be used for any evaporator temperature from -40°F to +40°F since the variation in the actual factors across this range is insignificant.

R-407C balanced ported valves (tons) NXT-R / B / HF / TFE / TRAE / T Series

Valve type	Nom. rating	Evaporator temperature																	
		50°F						40°F						20°F					
		Pressure drop across valve (psi)																	
		60	80	100	125	150	175	60	80	100	125	150	175	60	80	100	125	150	175
NXT-R	1/10	0.05	0.06	0.06	0.07	0.08	0.09	0.05	0.06	0.06	0.07	0.08	0.08	0.05	0.06	0.06	0.07	0.08	0.08
NXT-R	1/5	0.13	0.15	0.16	0.18	0.2	0.21	0.12	0.14	0.16	0.18	0.2	0.21	0.12	0.14	0.15	0.17	0.19	0.2
NXT-R	1/4	0.33	0.38	0.42	0.47	0.52	0.56	0.32	0.37	0.41	0.46	0.51	0.55	0.31	0.36	0.4	0.45	0.49	0.53
NXT-R	1/2	0.54	0.63	0.7	0.79	0.86	0.93	0.54	0.62	0.69	0.77	0.85	0.91	0.52	0.6	0.67	0.75	0.82	0.88
NXT-R	1	0.73	0.84	0.94	1.05	1.15	1.24	0.72	0.83	0.93	1.03	1.13	1.22	0.69	0.8	0.89	1	1.09	1.18
NXT-R	1 1/4	1.31	1.51	1.69	1.89	2.07	2.23	1.29	1.48	1.66	1.86	2.03	2.2	1.24	1.43	1.6	1.79	1.96	2.12
NXT-R	2	1.74	2.01	2.25	2.51	2.75	2.98	1.71	1.98	2.21	2.47	2.71	2.93	1.65	1.91	2.14	2.39	2.62	2.82
NXT-R	2 1/2	2.32	2.68	2.99	3.35	3.67	3.96	2.28	2.64	2.95	3.29	3.61	3.9	2.2	2.54	2.84	3.18	3.48	3.76
NXT-R	3	2.6	3	3.35	3.75	4.11	4.43	2.55	2.95	3.3	3.69	4.04	4.36	2.47	2.85	3.18	3.56	3.9	4.21
NXT-R	3 1/4	3.38	3.91	4.37	4.88	5.35	5.78	3.33	3.84	4.3	4.81	5.26	5.69	3.21	3.71	4.15	4.64	5.08	5.49
NXT-R	4	3.74	4.32	4.83	5.4	5.92	6.39	3.68	4.25	4.76	5.32	5.82	6.29	3.55	4.1	4.59	5.13	5.62	6.07
NXT-R	5	4.23	4.88	5.46	6.1	6.69	7.22	4.16	4.81	5.37	6.01	6.58	7.11	4.02	4.64	5.18	5.8	6.35	6.86
NXT-R	5 1/4	4.57	5.28	5.9	6.6	7.23	7.81	4.5	5.2	5.81	6.49	7.11	7.68	4.34	5.01	5.61	6.27	6.86	7.42
NXT-R	6	5.36	6.19	6.92	7.74	8.48	9.15	5.27	6.09	6.81	7.61	8.34	9.01	5.09	5.88	6.57	7.35	8.05	8.69
BA/BN	1/2	0.38	0.44	0.49	0.55	0.6	0.65	0.37	0.43	0.48	0.53	0.59	0.63	0.36	0.42	0.46	0.52	0.57	0.61
BA/BN	1	0.72	0.83	0.93	1.04	1.14	1.23	0.7	0.81	0.9	1.01	1.11	1.2	0.68	0.79	0.88	0.98	1.08	1.16
BA/BN	1-1/2	1.12	1.29	1.45	1.62	1.77	1.91	1.1	1.27	1.42	1.59	1.74	1.88	1.05	1.21	1.36	1.52	1.66	1.79
BA/BN	2	1.49	1.72	1.92	2.15	2.36	2.54	1.47	1.7	1.9	2.12	2.32	2.51	1.41	1.63	1.82	2.04	2.23	2.41
BA/BN	2-1/2	1.88	2.17	2.43	2.71	2.97	3.21	1.85	2.14	2.39	2.67	2.93	3.16	1.78	2.06	2.3	2.57	2.81	3.04
BA/BN	3	2.28	2.63	2.94	3.29	3.6	3.89	2.24	2.59	2.89	3.23	3.54	3.83	2.15	2.48	2.78	3.1	3.4	3.67
BA/BN	4	2.96	3.42	3.82	4.27	4.68	5.06	2.9	3.35	3.74	4.19	4.59	4.95	2.79	3.22	3.6	4.03	4.41	4.76
BA/BN	5	3.74	4.32	4.83	5.4	5.91	6.39	3.67	4.24	4.74	5.3	5.8	6.27	3.52	4.06	4.54	5.08	5.57	6.01
BA/BN	6	4.65	5.37	6	6.71	7.35	7.94	4.57	5.28	5.9	6.6	7.23	7.8	4.38	5.06	5.65	6.32	6.93	7.48
HF	1/4	0.21	0.24	0.27	0.3	0.33	0.36	0.21	0.24	0.27	0.3	0.33	0.36	0.2	0.23	0.26	0.29	0.32	0.34
HF	1/2	0.4	0.46	0.52	0.58	0.63	0.68	0.39	0.45	0.5	0.56	0.62	0.67	0.38	0.44	0.49	0.55	0.6	0.65
HF	1	0.72	0.83	0.93	1.04	1.14	1.23	0.7	0.81	0.9	1.01	1.11	1.2	0.68	0.79	0.88	0.98	1.08	1.16
HF	1-1/2	1.09	1.26	1.41	1.57	1.72	1.86	1.07	1.24	1.38	1.54	1.69	1.83	1.03	1.19	1.33	1.49	1.63	1.76
HF	2	1.47	1.7	1.9	2.12	2.32	2.51	1.44	1.66	1.86	2.08	2.28	2.46	1.39	1.61	1.79	2.01	2.2	2.37
HF	2-1/2	1.88	2.17	2.43	2.71	2.97	3.21	1.85	2.14	2.39	2.67	2.93	3.16	1.78	2.06	2.3	2.57	2.81	3.04
HF	3	2.49	2.88	3.21	3.59	3.94	4.25	2.44	2.82	3.15	3.52	3.86	4.17	2.35	2.71	3.03	3.39	3.72	4.01
HF	5-1/2	4.43	5.12	5.72	6.39	7	7.57	4.34	5.01	5.6	6.26	6.86	7.41	4.17	4.82	5.38	6.02	6.59	7.12
HF	8	6.16	7.11	7.95	8.89	9.74	10.52	6.05	6.99	7.81	8.73	9.57	10.33	5.81	6.71	7.5	8.39	9.19	9.92
HF	10	7.8	9.01	10.07	11.26	12.33	13.32	7.65	8.83	9.88	11.04	12.1	13.06	7.35	8.49	9.49	10.61	11.62	12.55
HF	15	11.57	13.36	14.94	16.7	18.29	19.76	11.35	13.11	14.65	16.38	17.95	19.38	10.9	12.59	14.07	15.73	17.23	18.62
HF	20	15.22	17.57	19.65	21.97	24.06	25.99	14.94	17.25	19.29	21.56	23.62	25.51	14.35	16.57	18.53	20.71	22.69	24.51
TFE	8	6.05	6.99	7.81	8.73	9.57	10.33	5.94	6.86	7.67	8.57	9.39	10.14	5.7	6.58	7.36	8.23	9.01	9.73
TFE	10	8.28	9.56	10.69	11.95	13.09	14.14	8.13	9.39	10.5	11.73	12.85	13.88	7.8	9.01	10.07	11.26	12.33	13.32
TFE	12	10.28	11.87	13.27	14.84	16.25	17.56	10.09	11.65	13.03	14.56	15.95	17.23	9.69	11.19	12.51	13.99	15.32	16.55
TFE	20	15.69	18.12	20.26	22.65	24.81	26.8	15.4	17.78	19.88	22.23	24.35	26.3	14.79	17.08	19.09	21.35	23.39	25.26
TRAE+	10	8.9	10.28	11.49	12.85	14.07	15.2	8.73	10.08	11.27	12.6	13.8	14.91	8.39	9.69	10.83	12.11	13.27	14.33
TRAE+	15	12.97	14.98	16.74	18.72	20.51	22.15	12.73	14.7	16.43	18.37	20.13	21.74	12.22	14.11	15.78	17.64	19.32	20.87
TRAE+	20	14.48	16.72	18.69	20.9	22.89	24.73	14.21	16.41	18.35	20.51	22.47	24.27	13.64	15.75	17.61	19.69	21.57	23.29
TRAE+	30	21.94	25.33	28.32	31.67	34.69	37.47	21.45	24.77	27.69	30.96	33.92	36.63	20.68	23.88	26.7	29.85	32.7	35.32
TRAE+	40	30.16	34.83	38.94	43.53	47.69	51.51	29.6	34.18	38.21	42.72	46.8	50.55	28.43	32.83	36.7	41.04	44.95	48.55
TRAE	50	40.71	47.01	52.56	58.76	64.37	69.53	39.97	46.15	51.6	57.69	63.2	68.26	38.37	44.31	49.54	55.38	60.67	65.53
TRAE	60	44.41	51.28	57.33	64.1	70.22	75.84	43.59	50.33	56.27	62.92	68.92	74.44	41.86	48.34	54.04	60.42	66.19	71.49
TRAE	70	52.85	61.03	68.23	76.28	83.56	90.26	51.88	59.91	66.98	74.88	82.03	88.6	49.82	57.53	64.32	71.91	78.77	85.08
TJR	14	11.08	12.79	14.3	15.99	17.52	18.92	10.88	12.56	14.05	15.7	17.2	18.58	10.45	12.07	13.49	15.08	16.52	17.85
TJR	18	13.27	15.32	17.13	19.15	20.98	22.66	13.03	15.05	16.82	18.81	20.6	22.25	12.51	14.45	16.15	18.06	19.78	21.36
TER	22	16.59	19.16	21.42	23.95	26.23	28.33	16.28	18.8	21.02	23.5	25.74	27.8	15.63	18.05	20.18	22.56	24.71	26.69
TER	26	19.6	22.63	25.3	28.29	30.99	33.47	19.24	22.22	24.84	27.77	30.42	32.86	18.48	21.34	23.86	26.67	29.22	31.56
TER	35	26.39	30.47	34.07	38.09	41.73	45.07	25.9	29.91	33.44	37.38	40.95	44.23	24.87	28.72	32.11	35.9	39.32	42.47
TER	45	33.93	39.18	43.8	48.97	53.65	57.95	33.3	38.45	42.99	48.06	52.65	56.87	31.98	36.93	41.29	46.16	50.56	54.62
TIR	55	41.47	47.89	53.54	59.86	65.57	70.82	40.71	47.01	52.56	58.76	64.37	69.53	39.08	45.13	50.45	56.41	61.79	66.74
THR	75	52.78	60.95	68.14	76.18	83.45	90.14	51.81	59.83	66.89	74.78	81.92	88.48	49.74	57.43	64.21	71.79	78.65	84.95
THR	100	64.08	73.99	82.73	92.49	101.32	109.44	62.91	72.64	81.22	90.8	99.47	107.44	60.4	69.74	77.98	87.18	95.5	103.15
TMR	100	75.39	87.05	97.33	108.82	119.2	128.75	74.01	85.46	95.55	106.82	117.02	126.4	71.06	82.05	91.74	102.57	112.36	121.36

NOTE: Standard capacity is rated at 100°F liquid inlet and 40°F evaporator temperature; with 100 PSI pressure drop across the TXV per ARI 750-2001.

R-407C balanced ported valves (tons) NXT-R / B / HF / TFE / TRAE / T Series (cont'd)

Valve type	Nom. rating	Evaporator temperature																	
		0°F						-20°F						-40°F					
		Pressure drop across valve (psi)						Pressure drop across valve (psi)						Pressure drop across valve (psi)					
		60	80	100	125	150	175	80	100	125	150	175	200	80	100	125	150	175	200
NXT-R	1/10	0.04	0.05	0.05	0.06	0.06	0.07	0.03	0.03	0.04	0.04	0.05	0.05	0.02	0.02	0.02	0.03	0.03	0.03
NXT-R	1/5	0.10	0.12	0.13	0.15	0.16	0.17	0.08	0.09	0.10	0.11	0.12	0.12	0.05	0.05	0.06	0.07	0.07	0.08
NXT-R	1/4	0.26	0.31	0.34	0.38	0.42	0.45	0.20	0.23	0.25	0.28	0.30	0.32	0.13	0.14	0.16	0.18	0.19	0.20
NXT-R	1/2	0.44	0.51	0.57	0.64	0.70	0.75	0.34	0.38	0.42	0.46	0.50	0.53	0.21	0.24	0.27	0.29	0.32	0.34
NXT-R	1	0.59	0.68	0.76	0.85	0.93	1.01	0.45	0.51	0.56	0.62	0.67	0.71	0.29	0.32	0.36	0.39	0.42	0.45
NXT-R	1 1/4	1.06	1.22	1.36	1.53	1.67	1.81	0.81	0.91	1.01	1.11	1.20	1.28	0.51	0.57	0.64	0.70	0.76	0.81
NXT-R	2	1.41	1.63	1.82	2.03	2.23	2.41	1.08	1.21	1.35	1.48	1.60	1.71	0.68	0.76	0.85	0.93	1.01	1.08
NXT-R	2 1/2	1.88	2.17	2.42	2.71	2.97	3.21	1.44	1.61	1.80	1.97	2.13	2.27	0.91	1.02	1.14	1.24	1.34	1.44
NXT-R	3	2.10	2.43	2.71	3.03	3.32	3.59	1.61	1.80	2.01	2.20	2.38	2.55	1.02	1.14	1.27	1.39	1.50	1.61
NXT-R	3 1/4	2.74	3.16	3.53	3.95	4.33	4.67	2.10	2.35	2.62	2.87	3.10	3.32	1.32	1.48	1.66	1.81	1.96	2.09
NXT-R	4	3.03	3.50	3.91	4.37	4.79	5.17	2.32	2.60	2.90	3.18	3.43	3.67	1.47	1.64	1.83	2.01	2.17	2.32
NXT-R	5	3.42	3.95	4.42	4.94	5.41	5.84	2.62	2.93	3.28	3.59	3.88	4.15	1.66	1.85	2.07	2.27	2.45	2.62
NXT-R	5 1/4	3.70	4.27	4.78	5.34	5.85	6.32	2.84	3.17	3.54	3.88	4.19	4.48	1.79	2.00	2.24	2.45	2.65	2.83
NXT-R	6	4.34	5.01	5.60	6.26	6.86	7.41	3.32	3.72	4.15	4.55	4.92	5.25	2.10	2.35	2.62	2.87	3.10	3.32
BA/BN	1/2	0.30	0.35	0.39	0.43	0.47	0.51	0.23	0.26	0.29	0.31	0.34	0.36	0.14	0.16	0.18	0.19	0.21	0.22
BA/BN	1	0.57	0.66	0.74	0.82	0.90	0.97	0.43	0.48	0.54	0.59	0.64	0.68	0.27	0.30	0.34	0.37	0.40	0.43
BA/BN	1-1/2	0.89	1.03	1.15	1.28	1.41	1.52	0.68	0.76	0.85	0.93	1.01	1.08	0.43	0.48	0.54	0.59	0.64	0.68
BA/BN	2	1.19	1.37	1.54	1.72	1.88	2.03	0.90	1.01	1.13	1.23	1.33	1.42	0.57	0.64	0.71	0.78	0.84	0.90
BA/BN	2-1/2	1.50	1.73	1.94	2.17	2.37	2.56	1.14	1.27	1.43	1.56	1.69	1.80	0.72	0.80	0.90	0.99	1.06	1.14
BA/BN	3	1.82	2.10	2.35	2.63	2.88	3.11	1.38	1.54	1.73	1.89	2.04	2.18	0.87	0.97	1.09	1.19	1.29	1.38
BA/BN	4	2.35	2.71	3.03	3.39	3.72	4.01	1.79	2.00	2.24	2.45	2.65	2.83	1.13	1.26	1.41	1.55	1.67	1.79
BA/BN	5	2.98	3.44	3.85	4.30	4.71	5.09	2.27	2.54	2.84	3.11	3.36	3.59	1.43	1.60	1.79	1.96	2.11	2.26
BA/BN	6	3.70	4.27	4.78	5.34	5.85	6.32	2.82	3.15	3.53	3.86	4.17	4.46	1.77	1.98	2.21	2.42	2.62	2.80
HF	1/4	0.17	0.20	0.22	0.25	0.27	0.29	0.13	0.15	0.16	0.18	0.19	0.21	0.08	0.09	0.10	0.11	0.12	0.13
HF	1/2	0.32	0.37	0.41	0.46	0.51	0.55	0.24	0.27	0.30	0.33	0.35	0.38	0.15	0.17	0.19	0.21	0.22	0.24
HF	1	0.57	0.66	0.74	0.82	0.90	0.97	0.43	0.48	0.54	0.59	0.64	0.68	0.27	0.30	0.34	0.37	0.40	0.43
HF	1-1/2	0.87	1.00	1.12	1.26	1.38	1.49	0.66	0.74	0.83	0.90	0.98	1.04	0.42	0.47	0.53	0.58	0.62	0.66
HF	2	1.17	1.35	1.51	1.69	1.85	2.00	0.89	1.00	1.11	1.22	1.32	1.41	0.56	0.63	0.70	0.77	0.83	0.89
HF	2-1/2	1.50	1.73	1.94	2.17	2.37	2.56	1.14	1.27	1.43	1.56	1.69	1.80	0.72	0.80	0.90	0.99	1.06	1.14
HF	3	1.98	2.29	2.56	2.86	3.13	3.38	1.51	1.69	1.89	2.07	2.23	2.39	0.95	1.06	1.19	1.30	1.41	1.50
HF	5-1/2	3.52	4.06	4.54	5.08	5.57	6.01	2.68	3.00	3.35	3.67	3.96	4.24	1.69	1.89	2.11	2.31	2.50	2.67
HF	8	4.90	5.66	6.33	7.07	7.75	8.37	3.73	4.17	4.66	5.11	5.52	5.90	2.35	2.63	2.94	3.22	3.48	3.72
HF	10	6.20	7.16	8.00	8.95	9.80	10.59	4.72	5.28	5.90	6.46	6.98	7.46	2.97	3.32	3.71	4.07	4.39	4.70
HF	15	9.20	10.62	11.88	13.28	14.55	15.71	7.01	7.84	8.76	9.60	10.37	11.08	4.41	4.93	5.51	6.04	6.52	6.97
HF	20	12.11	13.98	15.63	17.48	19.15	20.68	9.22	10.31	11.53	12.63	13.64	14.58	5.81	6.50	7.26	7.96	8.59	9.19
TFE	8	4.81	5.55	6.21	6.94	7.61	8.21	3.66	4.09	4.58	5.01	5.41	5.79	2.31	2.58	2.89	3.16	3.42	3.65
TFE	10	6.59	7.61	8.51	9.51	10.42	11.25	5.02	5.61	6.28	6.87	7.42	7.94	3.16	3.53	3.95	4.33	4.67	5.00
TFE	12	8.18	9.45	10.56	11.81	12.93	13.97	6.23	6.97	7.79	8.53	9.21	9.85	3.92	4.38	4.90	5.37	5.80	6.20
TFE	20	12.49	14.42	16.12	18.03	19.75	21.33	9.51	10.63	11.89	13.02	14.07	15.04	5.98	6.69	7.48	8.19	8.84	9.46
TRAE+	10	7.08	8.18	9.14	10.22	11.19	12.09	5.39	6.03	6.74	7.38	7.97	8.52	3.39	3.79	4.24	4.64	5.01	5.36
TRAE+	15	10.32	11.92	13.32	14.90	16.32	17.62	7.86	8.79	9.83	10.76	11.63	12.43	4.95	5.53	6.19	6.78	7.32	7.83
TRAE+	20	11.52	13.30	14.87	16.63	18.21	19.67	8.77	9.81	10.96	12.01	12.97	13.87	5.52	6.17	6.90	7.56	8.16	8.73
TRAE+	30	17.46	20.16	22.54	25.20	27.61	29.82	13.30	14.87	16.63	18.21	19.67	21.03	8.37	9.36	10.46	11.46	12.38	13.23
TRAE+	40	24.00	27.71	30.98	34.64	37.95	40.99	18.28	20.44	22.85	25.03	27.04	28.90	11.50	12.86	14.38	15.75	17.01	18.18
TRAE	50	32.40	37.41	41.83	46.77	51.23	55.33	24.67	27.58	30.84	33.78	36.49	39.01	15.53	17.36	19.41	21.27	22.97	24.56
TRAE	60	35.34	40.81	45.62	51.01	55.88	60.35	26.91	30.09	33.64	36.85	39.80	42.55	16.94	18.94	21.18	23.20	25.05	26.78
TRAE	70	42.06	48.57	54.30	60.71	66.50	71.83	32.03	35.81	40.04	43.86	47.37	50.64	20.16	22.54	25.20	27.61	29.82	31.88

R-407C balanced ported valves (tons) NXT-R / B / HF / TFE / TRAE / T Series (cont'd)

Valve type	Nom. rating	Evaporator temperature																	
		0°F						-20°F						-40°F					
		Pressure drop across valve (psi)						Pressure drop across valve (psi)						Pressure drop across valve (psi)					
		60	80	100	125	150	175	80	100	125	150	175	200	80	100	125	150	175	200
TJR	14	8.82	10.18	11.39	12.73	13.95	15.06	6.72	7.51	8.40	9.20	9.94	10.63	4.23	4.73	5.29	5.79	6.26	6.69
TJR	18	10.56	12.19	13.63	15.24	16.70	18.03	8.04	8.99	10.05	11.01	11.89	12.71	5.06	5.66	6.33	6.93	7.48	8.00
TER	22	13.20	15.24	17.04	19.05	20.87	22.54	10.05	11.24	12.56	13.76	14.86	15.89	6.33	7.08	7.91	8.67	9.36	10.01
TER	26	15.60	18.01	20.14	22.52	24.67	26.64	11.88	13.28	14.85	16.27	17.57	18.78	7.48	8.36	9.35	10.24	11.06	11.83
TER	35	21.00	24.25	27.11	30.31	33.20	35.86	15.99	17.88	19.99	21.90	23.65	25.28	10.06	11.25	12.58	13.78	14.88	15.91
TER	45	27.00	31.18	34.86	38.97	42.69	46.11	20.56	22.99	25.70	28.15	30.41	32.51	12.94	14.47	16.18	17.72	19.14	20.46
TIR	55	33.00	38.11	42.60	47.63	52.18	56.36	25.13	28.10	31.41	34.41	37.17	39.73	15.82	17.69	19.78	21.66	23.40	25.01
THR	75	42.00	48.50	54.22	60.62	66.41	71.73	31.98	35.75	39.98	43.79	47.30	50.56	20.13	22.51	25.16	27.56	29.77	31.83
THR	100	51.00	58.89	65.84	73.61	80.64	87.10	38.84	43.42	48.55	53.18	57.45	61.41	24.44	27.32	30.55	33.47	36.15	38.64
TMR	100	60.00	69.28	77.46	86.60	94.87	102.47	45.69	51.08	57.11	62.56	67.58	72.24	28.76	32.15	35.95	39.38	42.54	45.47

Refrigerant liquid temperature correction factors

	Refrigerant liquid temperature °F															
	0	10	20	30	40	50	60	70	80	90	100	110	120	130	140	
R-407C	1.72	1.65	1.58	1.51	1.44	1.37	1.29	1.22	1.15	1.07	1.00	0.92	0.85	0.77	0.69	

NOTE: These factors include corrections for liquid refrigerant density and net refrigerating effect and are based on an average evaporator temperature of 0°F. However, they may be used for any evaporator temperature from -40°F to +40°F since the variation in the actual factors across this range is insignificant.

R-407H (tons) balance ported valves - NXT-R / B-Series / H-Series

Valve type	Nom. rating	Evaporator temperature																	
		50°F						40°F						20°F					
		Pressure drop across valve (psi)						Pressure drop across valve (psi)						Pressure drop across valve (psi)					
		60	80	100	125	150	175	60	80	100	125	150	175	60	80	100	125	150	175
NXT-R	1/8	0.14	0.16	0.18	0.2	0.22	0.24	0.14	0.16	0.18	0.2	0.22	0.23	0.13	0.15	0.17	0.19	0.21	0.23
NXT-R	1/4	0.36	0.42	0.47	0.52	0.57	0.62	0.36	0.41	0.46	0.51	0.56	0.61	0.35	0.4	0.45	0.5	0.55	0.59
NXT-R	1/2	0.6	0.7	0.78	0.87	0.95	1.03	0.59	0.69	0.77	0.86	0.94	1.02	0.58	0.67	0.74	0.83	0.91	0.98
NXT-R	3/4	0.81	0.93	1.04	1.16	1.28	1.38	0.8	0.92	1.03	1.15	1.26	1.36	0.77	0.89	1	1.11	1.22	1.32
NXT-R	1	1.45	1.67	1.87	2.09	2.29	2.47	1.43	1.65	1.84	2.06	2.26	2.44	1.38	1.6	1.79	2	2.19	2.36
NXT-R	1 1/4	1.93	2.23	2.49	2.78	3.05	3.29	1.9	2.2	2.46	2.75	3.01	3.25	1.84	2.13	2.38	2.66	2.92	3.15
NXT-R	1 1/2	2.57	2.97	3.32	3.71	4.06	4.39	2.53	2.93	3.27	3.66	4.01	4.33	2.46	2.84	3.17	3.55	3.88	4.2
NXT-R	2	2.87	3.32	3.71	4.15	4.54	4.91	2.83	3.27	3.66	4.09	4.48	4.84	2.75	3.17	3.55	3.97	4.35	4.69
NXT-R	2 1/2	3.75	4.33	4.84	5.41	5.92	6.4	3.69	4.27	4.77	5.33	5.84	6.31	3.58	4.14	4.63	5.17	5.66	6.12
NXT-R	3	4.14	4.79	5.35	5.98	6.55	7.08	4.09	4.72	5.28	5.9	6.46	6.98	3.96	4.58	5.12	5.72	6.27	6.77
NXT-R	3 1/2	5.06	5.85	6.54	7.31	8	8.65	4.99	5.77	6.45	7.21	7.89	8.53	4.84	5.59	6.25	6.99	7.66	8.27
NXT-R	4	5.93	6.85	7.66	8.57	9.38	10.13	5.85	6.76	7.56	8.45	9.25	10	5.68	6.55	7.33	8.19	8.97	9.69
NXT-R	5 1/2	7.27	8.39	9.38	10.49	11.49	12.41	7.17	8.28	9.26	10.35	11.34	12.24	6.95	8.03	8.98	10.04	10.99	11.87
BA/BN	1/2	0.46	0.54	0.6	0.67	0.73	0.79	0.46	0.53	0.59	0.66	0.72	0.78	0.44	0.51	0.57	0.64	0.7	0.76
BA/BN	1	0.88	1.02	1.14	1.27	1.39	1.5	0.87	1	1.12	1.25	1.37	1.48	0.84	0.97	1.09	1.22	1.33	1.44
BA/BN	1-3/4	1.37	1.58	1.77	1.98	2.17	2.34	1.35	1.56	1.75	1.95	2.14	2.31	1.31	1.52	1.69	1.89	2.08	2.24
BA/BN	2	1.84	2.12	2.37	2.65	2.9	3.14	1.81	2.09	2.34	2.61	2.86	3.09	1.76	2.03	2.27	2.53	2.78	3
BA/BN	3	2.32	2.68	2.99	3.35	3.67	3.96	2.29	2.64	2.95	3.3	3.61	3.9	2.22	2.56	2.86	3.2	3.51	3.79
BA/BN	3-1/2	2.81	3.24	3.63	4.06	4.44	4.8	2.77	3.2	3.58	4	4.38	4.73	2.69	3.1	3.47	3.88	4.25	4.59
BA/BN	4-1/2	3.63	4.2	4.69	5.25	5.75	6.21	3.58	4.14	4.63	5.17	5.67	6.12	3.48	4.01	4.49	5.02	5.5	5.94
BA/BN	6	4.61	5.32	5.95	6.65	7.29	7.87	4.55	5.25	5.87	6.56	7.19	7.76	4.41	5.09	5.69	6.36	6.97	7.53
BA/BN	7-1/2	5.72	6.61	7.39	8.26	9.05	9.77	5.64	6.52	7.28	8.14	8.92	9.64	5.47	6.32	7.06	7.9	8.65	9.34
HF	1/4	0.24	0.28	0.31	0.35	0.38	0.41	0.24	0.27	0.31	0.34	0.38	0.41	0.23	0.27	0.3	0.33	0.36	0.39
HF	1/2	0.46	0.53	0.59	0.66	0.72	0.78	0.45	0.52	0.58	0.65	0.71	0.77	0.44	0.5	0.56	0.63	0.69	0.75
HF	1	0.82	0.94	1.06	1.18	1.29	1.4	0.81	0.93	1.04	1.16	1.28	1.38	0.78	0.9	1.01	1.13	1.24	1.34
HF	1-1/2	1.25	1.44	1.61	1.8	1.97	2.13	1.23	1.42	1.59	1.78	1.95	2.1	1.19	1.38	1.54	1.72	1.89	2.04
HF	2	1.69	1.95	2.18	2.44	2.67	2.88	1.67	1.92	2.15	2.4	2.63	2.84	1.62	1.87	2.09	2.33	2.55	2.76
HF	2-3/4	2.16	2.5	2.79	3.12	3.42	3.69	2.13	2.46	2.75	3.08	3.37	3.64	2.07	2.39	2.67	2.99	3.27	3.53
HF	3-1/2	2.85	3.29	3.68	4.11	4.51	4.87	2.81	3.25	3.63	4.06	4.45	4.8	2.73	3.15	3.52	3.94	4.31	4.66
HF	6-1/2	5.07	5.86	6.55	7.32	8.02	8.66	5	5.78	6.46	7.22	7.91	8.55	4.85	5.6	6.27	7.01	7.67	8.29
HF	9	7.05	8.14	9.11	10.18	11.15	12.05	6.96	8.03	8.98	10.04	11	11.88	6.75	7.79	8.71	9.74	10.67	11.53
HF	11-1/2	8.96	10.34	11.56	12.93	14.16	15.3	8.83	10.2	11.41	12.75	13.97	15.09	8.57	9.9	11.06	12.37	13.55	14.64
HF	17	13.26	15.31	17.12	19.14	20.97	22.65	13.08	15.11	16.89	18.88	20.69	22.34	12.69	14.65	16.38	18.32	20.07	21.67
HF	22	17.4	20.09	22.46	25.11	27.51	29.71	17.16	19.81	22.15	24.77	27.13	29.31	16.65	19.22	21.49	24.03	26.32	28.43

NOTE: Standard capacity is rated at 100°F liquid inlet and 40°F evaporator temperature; with 100 PSI pressure drop across the TXV.

R-407H (tons) balance ported valves - NXT-R / B-Series / H-Series (cont'd)

Valve type	Nom. rating	Evaporator temperature																	
		0°F						-20°F						-40°F					
		Pressure drop across valve (psi)						Pressure drop across valve (psi)						Pressure drop across valve (psi)					
		60	80	100	125	150	175	80	100	125	150	175	200	80	100	125	150	175	200
NXT-R	1/8	0.12	0.14	0.15	0.17	0.19	0.20	0.09	0.10	0.11	0.13	0.14	0.14	0.06	0.07	0.07	0.08	0.09	0.09
NXT-R	1/4	0.31	0.36	0.40	0.44	0.49	0.53	0.24	0.27	0.30	0.33	0.35	0.38	0.15	0.17	0.19	0.21	0.22	0.24
NXT-R	1/2	0.51	0.59	0.66	0.74	0.81	0.88	0.40	0.44	0.50	0.54	0.59	0.63	0.25	0.28	0.32	0.35	0.37	0.40
NXT-R	3/4	0.69	0.79	0.89	0.99	1.09	1.17	0.53	0.59	0.66	0.73	0.78	0.84	0.34	0.38	0.42	0.46	0.50	0.53
NXT-R	1	1.23	1.42	1.59	1.78	1.95	2.11	0.95	1.06	1.19	1.30	1.41	1.50	0.61	0.68	0.76	0.83	0.90	0.96
NXT-R	1 1/4	1.64	1.90	2.12	2.37	2.60	2.81	1.27	1.42	1.59	1.74	1.88	2.01	0.81	0.90	1.01	1.11	1.19	1.28
NXT-R	1 1/2	2.19	2.53	2.83	3.16	3.46	3.74	1.69	1.89	2.11	2.31	2.50	2.67	1.07	1.20	1.34	1.47	1.59	1.70
NXT-R	2	2.45	2.83	3.16	3.54	3.87	4.18	1.89	2.11	2.36	2.59	2.80	2.99	1.20	1.34	1.50	1.65	1.78	1.90
NXT-R	2 1/2	3.19	3.69	4.12	4.61	5.05	5.45	2.46	2.76	3.08	3.37	3.64	3.90	1.57	1.75	1.96	2.15	2.32	2.48
NXT-R	3	3.53	4.08	4.56	5.10	5.59	6.03	2.73	3.05	3.41	3.73	4.03	4.31	1.73	1.94	2.17	2.37	2.57	2.74
NXT-R	3 1/2	4.32	4.98	5.57	6.23	6.82	7.37	3.33	3.72	4.16	4.56	4.93	5.27	2.12	2.37	2.65	2.90	3.13	3.35
NXT-R	4	5.06	5.84	6.53	7.30	8.00	8.64	3.90	4.36	4.88	5.35	5.77	6.17	2.48	2.78	3.10	3.40	3.67	3.93
NXT-R	5 1/2	6.20	7.15	8.00	8.94	9.80	10.58	4.78	5.35	5.98	6.55	7.07	7.56	3.04	3.40	3.80	4.17	4.50	4.81
BA/BN	1/2	0.40	0.46	0.51	0.57	0.62	0.67	0.31	0.34	0.38	0.42	0.45	0.48	0.19	0.22	0.24	0.27	0.29	0.31
BA/BN	1	0.75	0.87	0.97	1.08	1.19	1.28	0.58	0.65	0.72	0.79	0.86	0.92	0.37	0.41	0.46	0.50	0.55	0.58
BA/BN	1-3/4	1.17	1.35	1.51	1.69	1.85	2.00	0.90	1.01	1.13	1.24	1.34	1.43	0.57	0.64	0.72	0.79	0.85	0.91
BA/BN	2	1.56	1.81	2.02	2.26	2.47	2.67	1.21	1.35	1.51	1.65	1.79	1.91	0.77	0.86	0.96	1.05	1.14	1.21
BA/BN	3	1.98	2.28	2.55	2.85	3.12	3.37	1.53	1.71	1.91	2.09	2.26	2.41	0.97	1.08	1.21	1.33	1.43	1.53
BA/BN	3-1/2	2.39	2.77	3.09	3.46	3.79	4.09	1.85	2.07	2.31	2.53	2.73	2.92	1.18	1.31	1.47	1.61	1.74	1.86
BA/BN	4-1/2	3.10	3.58	4.00	4.47	4.90	5.29	2.39	2.67	2.99	3.27	3.54	3.78	1.52	1.70	1.90	2.08	2.25	2.40
BA/BN	6	3.93	4.54	5.07	5.67	6.21	6.71	3.03	3.39	3.79	4.15	4.48	4.79	1.93	2.16	2.41	2.64	2.85	3.05
BA/BN	7-1/2	4.88	5.63	6.30	7.04	7.71	8.33	3.76	4.21	4.70	5.15	5.57	5.95	2.39	2.68	2.99	3.28	3.54	3.79
HF	1/4	0.21	0.24	0.27	0.30	0.33	0.35	0.16	0.18	0.20	0.22	0.23	0.25	0.10	0.11	0.13	0.14	0.15	0.16
HF	1/2	0.39	0.45	0.50	0.56	0.62	0.67	0.30	0.34	0.38	0.41	0.44	0.48	0.19	0.21	0.24	0.26	0.28	0.30
HF	1	0.70	0.81	0.90	1.01	1.10	1.19	0.54	0.60	0.67	0.74	0.80	0.85	0.34	0.38	0.43	0.47	0.51	0.54
HF	1-1/2	1.07	1.23	1.38	1.54	1.68	1.82	0.82	0.92	1.03	1.13	1.22	1.30	0.52	0.59	0.65	0.72	0.77	0.83
HF	2	1.44	1.66	1.86	2.08	2.28	2.46	1.11	1.24	1.39	1.52	1.64	1.76	0.71	0.79	0.88	0.97	1.05	1.12
HF	2-3/4	1.84	2.13	2.38	2.66	2.92	3.15	1.42	1.59	1.78	1.95	2.11	2.25	0.91	1.01	1.13	1.24	1.34	1.43
HF	3-1/2	2.43	2.81	3.14	3.51	3.85	4.15	1.88	2.10	2.35	2.57	2.78	2.97	1.20	1.34	1.49	1.64	1.77	1.89
HF	6-1/2	4.33	5.00	5.59	6.25	6.84	7.39	3.34	3.74	4.18	4.58	4.94	5.28	2.13	2.38	2.66	2.91	3.15	3.36
HF	9	6.02	6.95	7.77	8.69	9.51	10.28	4.65	5.20	5.81	6.36	6.87	7.35	2.96	3.31	3.70	4.05	4.37	4.68
HF	11-1/2	7.64	8.82	9.87	11.03	12.08	13.05	5.90	6.60	7.38	8.08	8.73	9.33	3.76	4.20	4.69	5.14	5.55	5.94
HF	17	11.32	13.07	14.61	16.33	17.89	19.32	8.74	9.77	10.92	11.96	12.92	13.82	5.56	6.22	6.95	7.62	8.23	8.79
HF	22	14.84	17.14	19.16	21.42	23.47	25.35	11.46	12.81	14.33	15.69	16.95	18.12	7.29	8.16	9.12	9.99	10.79	11.53

Refrigerant liquid temperature correction factors

	Refrigerant liquid temperature °F														
	0	10	20	30	40	50	60	70	80	90	100	110	120	130	140
R-407H	1.65	1.59	1.52	1.46	1.40	1.33	1.27	1.20	1.13	1.07	1.00	0.93	0.86	0.79	0.71

NOTE: These factors include corrections for liquid refrigerant density and net refrigeration effect, and are based on an average evaporator temperature of 0°F with a maximum 7°F Change in Superheat. However, they may be used for any evaporator temperature from -40°F to +40°F since the variation in the actual factors across this range is insignificant.

R-410A balanced ported valves (tons) B Series

Valve type	Nom. rating	Evaporator temperature																				
		50 °F							40 °F							20 °F						
		Pressure drop across valve (psi)							Pressure drop across valve (psi)							Pressure drop across valve (psi)						
		75	110	140	160	210	240	285	75	110	140	160	210	240	285	75	110	140	160	210	240	285
BA/BN	1	0.8	1.0	1.1	1.2	1.3	1.4	1.6	0.8	1.0	1.1	1.2	1.3	1.4	1.5	0.8	0.9	1.1	1.1	1.3	1.4	1.5
	1-1/2	1.3	1.6	1.8	1.9	2.2	1.4	1.6	1.3	1.6	1.7	1.9	2.1	2.3	2.5	1.3	1.5	1.7	1.8	2.1	2.2	2.4
	2	1.8	2.2	2.5	2.6	3.0	3.2	3.5	1.8	2.2	2.4	2.6	3.0	3.2	3.5	1.7	2.1	2.4	2.6	2.9	3.1	3.4
	3	2.3	2.8	3.1	3.3	3.8	4.1	4.5	2.3	2.8	3.1	3.3	3.8	4.1	4.4	2.2	2.7	3.0	3.2	3.7	4.0	4.3
	3-1/2	3.0	3.6	4.0	4.3	5.0	5.3	5.8	2.9	3.6	4.0	4.3	4.9	5.3	5.7	2.9	3.5	3.9	4.2	4.8	5.1	5.6
	4-1/2	4.1	5.0	5.6	6.0	6.9	7.4	8.0	4.1	5.0	5.6	6.0	6.9	7.3	8.0	4.0	4.9	5.5	5.9	6.7	7.2	7.8
	6	5.1	6.1	6.9	7.4	8.5	9.0	9.9	5.0	6.1	6.8	7.3	8.4	9.0	9.8	4.9	5.9	6.7	7.2	8.2	8.8	9.6
7-1/2	6.2	7.5	8.5	9.1	10.4	11.1	12.1	6.2	7.5	8.4	9.0	10.3	11.0	12.0	6.0	7.3	8.2	8.8	10.1	10.8	11.8	

Valve type	Nom. rating	Evaporator temperature																				
		0 °F							-20 °F							-40 °F						
		Pressure drop across valve (psi)							Pressure drop across valve (psi)							Pressure drop across valve (psi)						
		75	110	140	160	210	240	285	75	110	140	160	210	240	285	75	110	140	160	210	240	285
BA/BN	1	0.8	0.9	1.0	1.1	1.3	1.4	1.5	0.7	0.9	1.0	1.1	1.2	1.3	1.4	0.7	0.9	1.0	1.0	1.2	1.3	1.4
	1-1/2	1.2	1.5	1.7	1.8	2.0	2.2	2.4	1.2	1.4	1.6	1.7	2.0	2.1	2.3	1.1	1.4	1.6	1.7	1.9	2.0	2.2
	2	1.7	2.1	2.3	2.5	2.8	3.0	3.3	1.6	2.0	2.3	2.4	2.8	3.0	3.2	1.6	1.9	2.2	2.3	2.7	2.8	3.1
	3	2.2	2.6	3.0	3.2	3.6	3.9	4.2	2.1	2.5	2.9	3.1	3.5	3.8	4.1	2.0	2.5	2.8	3.0	3.4	3.6	3.9
	3-1/2	2.8	3.4	3.8	4.1	4.7	5.0	5.5	2.7	3.3	3.7	4.0	4.5	4.8	5.3	2.6	3.2	3.6	3.8	4.4	4.7	5.1
	4-1/2	3.9	4.7	5.3	5.7	6.5	7.0	7.6	3.8	4.6	5.2	5.5	6.3	6.8	7.4	3.6	4.4	5.0	5.3	6.1	6.5	7.1
	6	4.8	5.8	6.5	7.0	8.0	8.5	9.3	4.6	5.6	6.3	6.8	7.7	8.3	9.0	4.5	5.4	6.1	6.5	7.5	8.0	8.7
7-1/2	5.9	7.1	8.0	8.6	9.8	10.5	11.4	5.7	6.9	7.8	8.3	9.5	10.2	11.1	5.5	6.6	7.5	8.0	9.2	9.8	10.7	

NOTE: Standard capacity is rated at 100°F liquid inlet and 40°F evap temperature; with 160 PSI pressure drop across TXV per ARI-750-2001. These ratings assume vapor free liquid entering the thermal expansion valve.

R-410A balanced ported valves (tons) NXT Series

Valve type	Nom. rating	Evaporator temperature																				
		50 °F							40 °F							20 °F						
		Pressure drop across valve (psi)							Pressure drop across valve (psi)							Pressure drop across valve (psi)						
		75	110	140	160	210	240	285	75	110	140	160	210	240	285	75	110	140	160	210	240	285
NXT Series	1/2	0.4	0.5	0.5	0.6	0.6	0.7	0.8	0.4	0.5	0.5	0.6	0.6	0.7	0.7	0.4	0.5	0.5	0.5	0.6	0.7	0.7
	1	0.7	0.8	0.9	1.0	1.2	1.2	1.3	0.7	0.8	0.9	1.0	1.1	1.2	1.3	0.7	0.8	0.9	1.0	1.1	1.2	1.3
	1-1/2	1.0	1.3	1.4	1.5	1.7	1.9	2.0	1.0	1.2	1.4	1.5	1.7	1.8	2.0	1.0	1.2	1.4	1.5	1.7	1.8	2.0
	2	1.4	1.7	1.9	2.0	2.3	2.5	2.7	1.4	1.7	1.9	2.0	2.3	2.4	2.7	1.3	1.6	1.8	2.0	2.2	2.4	2.6
	3	2.1	2.5	2.8	3.0	3.5	3.7	4.0	2.1	2.5	2.8	3.0	3.4	3.7	4.0	2.0	2.4	2.7	2.9	3.4	3.6	3.9
	4	2.8	3.3	3.8	4.0	4.6	4.9	5.4	2.7	3.3	3.7	4.0	4.6	4.9	5.3	2.7	3.2	3.7	3.9	4.5	4.8	5.2
	5	3.5	4.2	4.7	5.0	5.8	6.2	6.7	3.4	4.1	4.7	5.0	5.7	6.1	6.7	3.3	4.1	4.6	4.9	5.6	6.0	6.5
	6	4.1	5.0	5.7	6.1	6.9	7.4	8.1	4.1	5.0	5.6	6.0	6.9	7.3	8.0	4.0	4.9	5.5	5.9	6.7	7.2	7.8
	7	4.8	5.9	6.6	7.1	8.1	8.6	9.4	4.8	5.8	6.5	7.0	8.0	8.6	9.3	4.7	5.7	6.4	6.8	7.8	8.4	9.1
	8	5.8	7.0	7.9	8.5	9.7	10.4	11.3	5.7	7.0	7.8	8.4	9.6	10.3	11.2	5.6	6.8	7.7	8.2	9.4	10.1	11.0
	10	7.1	8.6	9.7	10.4	11.9	12.7	13.9	7.1	8.5	9.6	10.3	11.8	12.6	13.8	6.9	8.4	9.4	10.1	11.6	12.4	13.5
	12	8.7	10.6	11.9	12.7	14.6	15.6	17.0	8.6	10.5	11.8	12.6	14.5	15.5	16.9	8.5	10.2	11.6	12.4	14.2	15.1	16.5
	15	10.2	12.4	14.0	14.9	17.1	18.3	19.9	10.1	12.3	13.8	14.8	16.9	18.1	19.7	9.9	12.0	13.5	14.5	16.6	17.7	19.3

R-410A balanced ported valves (tons) NXT Series

Valve type	Nom. rating	Evaporator temperature																				
		0 °F							-20 °F							-40 °F						
		Pressure drop across valve (psi)							Pressure drop across valve (psi)							Pressure drop across valve (psi)						
		75	110	140	160	210	240	285	75	110	140	160	210	240	285	75	110	140	160	210	240	285
NXT Series	1/2	0.4	0.4	0.5	0.5	0.6	0.7	0.7	0.4	0.4	0.5	0.5	0.6	0.6	0.7	0.3	0.4	0.5	0.6	0.6	0.6	0.7
	1	0.7	0.8	0.9	1.0	1.1	1.2	1.3	0.6	0.6	0.9	0.9	1.1	1.1	1.2	0.6	0.7	0.8	0.9	1.0	1.1	1.2
	1-1/2	1.0	1.2	1.3	1.4	1.6	1.8	1.9	0.9	1.1	1.3	1.4	1.6	1.7	1.8	0.9	1.1	1.2	1.3	1.5	1.6	1.8
	2	1.3	1.6	1.8	1.9	2.2	2.3	2.5	1.3	1.5	1.7	1.8	2.1	2.3	2.5	1.2	1.5	1.7	1.8	2.0	2.2	2.4
	3	2.0	2.4	2.7	2.9	3.3	3.5	3.8	1.9	2.3	2.6	2.8	3.2	3.4	3.7	1.8	2.2	2.5	2.7	3.1	3.3	3.6
	4	2.6	3.2	3.6	3.8	4.4	4.7	5.1	2.5	3.1	3.5	3.7	4.2	4.5	4.9	2.4	3.0	3.3	3.6	4.1	4.4	4.8
	5	3.3	3.9	4.5	4.8	5.5	5.8	6.4	3.2	3.8	4.3	4.6	5.3	5.7	6.2	3.0	3.7	4.2	4.5	5.1	5.5	5.9
	6	3.9	4.7	5.3	5.7	6.5	7.0	7.6	3.8	4.6	5.2	5.5	6.3	6.8	7.4	3.7	4.4	5.0	5.3	6.1	6.5	7.1
	7	4.8	5.9	6.6	6.7	8.1	8.6	9.4	4.4	5.4	6.0	6.5	7.4	7.9	8.6	4.3	5.2	5.8	6.2	7.1	7.6	8.3
	8	5.5	6.6	7.5	8.0	9.2	9.8	10.7	5.3	6.4	7.2	7.7	8.9	9.5	10.3	5.1	6.2	7.0	7.5	8.6	9.2	10.0
	10	6.7	8.1	9.2	9.8	11.3	12.0	13.1	6.5	7.9	8.9	9.5	10.9	11.7	12.7	6.3	7.6	8.6	9.2	10.5	11.2	12.3
	12	8.2	10.0	11.3	12.0	13.8	14.7	16.1	8.0	9.7	10.9	11.7	13.4	14.3	15.6	7.7	9.3	10.5	11.2	12.9	13.8	15.0
	15	9.6	11.7	13.2	14.1	16.1	17.3	18.8	9.3	11.3	12.8	13.7	15.6	16.7	18.2	9.0	10.3	12.3	13.2	15.1	15.1	17.6

NOTE: Standard capacity is rated at 100°F liquid inlet and 40°F evap temperature; with 160 PSI pressure drop across TXV per ARI-750-2001. These ratings assume vapor free liquid entering the thermal expansion valve.

R-410A balance ported valves (tons) TFE Series

Valve type	Nom. rating	Evaporator temperature																				
		50 °F							40 °F							20 °F						
		Pressure drop across valve (psi)							Pressure drop across valve (psi)							Pressure drop across valve (psi)						
		75	110	140	160	210	240	285	75	110	140	160	210	240	285	75	110	140	160	210	240	285
TFES	12	8.1	9.9	11.1	11.9	13.6	14.6	15.9	8.1	9.8	11.0	11.8	13.5	14.5	15.7	7.9	9.6	10.8	11.5	13.2	14.1	15.4
	16	12.4	15.0	16.9	18.1	20.7	22.1	24.1	12.3	14.8	16.7	17.9	20.5	21.9	23.9	12.0	14.5	16.4	17.5	20.1	21.5	23.4
	20	13.3	16.1	18.2	19.5	22.3	23.8	26.0	13.2	16.0	18.1	19.3	22.1	23.6	25.8	12.9	15.7	17.7	18.9	21.6	23.1	25.2

Valve type	Nom. rating	Evaporator temperature																				
		0 °F							-20 °F							-40 °F						
		Pressure drop across valve (psi)							Pressure drop across valve (psi)							Pressure drop across valve (psi)						
		75	110	140	160	210	240	285	75	110	140	160	210	240	285	75	110	140	160	210	240	285
TFES	12	7.7	9.3	10.5	11.2	12.9	13.8	15.0	7.5	9.0	10.2	10.9	12.5	13.3	14.5	7.2	8.7	9.8	10.5	12.0	12.9	14.0
	16	11.7	14.1	16.0	17.1	19.5	20.9	22.8	11.3	13.7	15.5	16.5	18.9	20.2	22.1	10.9	13.2	14.9	15.9	18.3	19.5	21.3
	20	12.6	15.2	17.2	18.4	21.1	22.5	24.5	12.2	14.8	16.7	17.8	20.4	21.8	23.8	11.8	14.3	16.1	17.2	19.7	21.1	22.9

NOTE: Standard capacity is rated at 100 °F liquid inlet and 40 °F evap temperature; with 160 PSI pressure drop across TXV per ARI 750-2001. These ratings assume vapor free liquid entering the thermal expansion valve.

Refrigerant liquid temperature correction factors

	Refrigerant liquid temperature °F									
	50	60	70	80	90	100	110	120	130	140
R-410A	1.37	1.30	1.23	1.15	1.08	1.00	0.92	0.84	0.75	0.65

NOTE: These factors include corrections for liquid refrigerant density and net refrigeration effect, and are based on an average evaporator temperature of 0°F with a maximum 7°F Change in Superheat. However, they may be used for any evaporator temperature from -40°F to +40°F since the variation in the actual factors across this range is insignificant.

R-448A / R-449A (tons) balance ported valves - NXT-R, B Series and H Series

Valve type	Nom. rating	Evaporator temperature																	
		50°F						40°F						20°F					
		Pressure drop across valve (psi)						Pressure drop across valve (psi)						Pressure drop across valve (psi)					
		60	80	100	125	150	175	60	80	100	125	150	175	60	80	100	125	150	175
NXT-R	1/5	0.12	0.14	0.15	0.17	0.19	0.20	0.12	0.14	0.15	0.17	0.19	0.20	0.11	0.13	0.15	0.16	0.18	0.19
NXT-R	1/4	0.31	0.36	0.40	0.45	0.49	0.53	0.30	0.35	0.39	0.44	0.48	0.52	0.29	0.34	0.38	0.42	0.46	0.50
NXT-R	1/2	0.52	0.60	0.67	0.74	0.82	0.88	0.51	0.59	0.66	0.73	0.80	0.87	0.49	0.56	0.63	0.71	0.77	0.83
NXT-R	1	0.69	0.80	0.89	1.00	1.09	1.18	0.68	0.78	0.88	0.98	1.07	1.16	0.65	0.75	0.84	0.94	1.03	1.12
NXT-R	1 1/2	1.24	1.43	1.60	1.79	1.96	2.12	1.22	1.41	1.57	1.76	1.93	2.08	1.17	1.35	1.51	1.69	1.85	2.00
NXT-R	2	1.65	1.91	2.13	2.38	2.61	2.82	1.62	1.87	2.10	2.34	2.57	2.77	1.56	1.81	2.02	2.26	2.47	2.67
NXT-R	2 1/2	2.20	2.54	2.84	3.17	3.48	3.76	2.16	2.50	2.79	3.12	3.42	3.69	2.08	2.40	2.69	3.00	3.29	3.56
NXT-R	3	2.46	2.84	3.18	3.55	3.89	4.20	2.42	2.79	3.12	3.49	3.83	4.13	2.33	2.69	3.01	3.36	3.68	3.98
NXT-R	3 1/2	3.21	3.70	4.14	4.63	5.07	5.48	3.15	3.64	4.07	4.55	4.99	5.39	3.04	3.51	3.92	4.38	4.80	5.19
NXT-R	4	3.55	4.10	4.58	5.12	5.61	6.06	3.49	4.03	4.50	5.04	5.52	5.96	3.36	3.88	4.34	4.85	5.31	5.74
NXT-R	5	4.01	4.63	5.18	5.79	6.34	6.85	3.94	4.55	5.09	5.69	6.23	6.73	3.80	4.38	4.90	5.48	6.00	6.48
NXT-R	5 1/2	4.34	5.01	5.60	6.26	6.86	7.40	4.26	4.92	5.50	6.15	6.74	7.28	4.10	4.74	5.30	5.92	6.49	7.01
NXT-R	6	5.08	5.87	6.56	7.34	8.04	8.68	5.00	5.77	6.45	7.21	7.90	8.53	4.81	5.55	6.21	6.94	7.61	8.21
BA/BN	1/2	0.40	0.46	0.52	0.58	0.64	0.69	0.40	0.46	0.51	0.57	0.63	0.68	0.39	0.45	0.50	0.56	0.61	0.66
BA/BN	1	0.76	0.88	0.99	1.10	1.21	1.30	0.76	0.87	0.97	1.09	1.19	1.29	0.74	0.85	0.95	1.06	1.17	1.26
BA/BN	1-1/2	1.19	1.37	1.53	1.72	1.88	2.03	1.18	1.36	1.52	1.70	1.86	2.01	1.15	1.33	1.48	1.66	1.82	1.96
BA/BN	2	1.59	1.84	2.05	2.30	2.51	2.72	1.57	1.82	2.03	2.27	2.49	2.69	1.54	1.77	1.98	2.22	2.43	2.62
BA/BN	2-1/2	2.01	2.32	2.59	2.90	3.18	3.43	1.99	2.29	2.57	2.87	3.14	3.39	1.94	2.24	2.50	2.80	3.07	3.31
BA/BN	3	2.43	2.81	3.14	3.51	3.85	4.16	2.41	2.78	3.11	3.48	3.81	4.11	2.35	2.71	3.04	3.39	3.72	4.02
BA/BN	4	3.15	3.64	4.06	4.54	4.98	5.38	3.12	3.60	4.02	4.50	4.93	5.32	3.04	3.51	3.93	4.39	4.81	5.19
BA/BN	5	3.99	4.61	5.15	5.76	6.31	6.82	3.95	4.56	5.10	5.70	6.25	6.75	3.86	4.45	4.98	5.57	6.10	6.59
BA/BN	6	4.96	5.72	6.40	7.15	7.84	8.46	4.90	5.66	6.33	7.08	7.75	8.38	4.79	5.53	6.18	6.91	7.57	8.18
HF	1/4	0.22	0.26	0.29	0.32	0.36	0.38	0.22	0.26	0.29	0.32	0.35	0.38	0.22	0.25	0.28	0.31	0.34	0.37
HF	1/2	0.43	0.49	0.55	0.61	0.67	0.73	0.42	0.49	0.54	0.61	0.67	0.72	0.41	0.47	0.53	0.59	0.65	0.70
HF	1	0.76	0.88	0.99	1.10	1.21	1.30	0.76	0.87	0.97	1.09	1.19	1.29	0.74	0.85	0.95	1.06	1.17	1.26
HF	1-1/2	1.16	1.34	1.50	1.68	1.84	1.99	1.15	1.33	1.49	1.66	1.82	1.97	1.13	1.30	1.45	1.62	1.78	1.92
HF	2	1.57	1.82	2.03	2.27	2.49	2.69	1.56	1.80	2.01	2.25	2.46	2.66	1.52	1.76	1.96	2.20	2.40	2.60
HF	2-1/2	2.02	2.33	2.60	2.91	3.19	3.44	2.00	2.30	2.58	2.88	3.15	3.41	1.95	2.25	2.51	2.81	3.08	3.33
HF	3-1/2	2.66	3.07	3.43	3.84	4.20	4.54	2.63	3.04	3.40	3.80	4.16	4.49	2.57	2.97	3.32	3.71	4.06	4.39
HF	6	4.73	5.46	6.11	6.83	7.48	8.08	4.68	5.41	6.04	6.76	7.40	8.00	4.57	5.28	5.90	6.60	7.23	7.81
HF	8-1/2	6.58	7.60	8.49	9.50	10.40	11.23	6.51	7.52	8.40	9.40	10.29	11.12	6.36	7.34	8.20	9.17	10.05	10.85
HF	10-1/2	8.35	9.65	10.78	12.06	13.21	14.27	8.27	9.55	10.67	11.93	13.07	14.12	8.07	9.32	10.42	11.65	12.76	13.78
HF	16	12.37	14.28	15.97	17.85	19.56	21.13	12.24	14.14	15.80	17.67	19.36	20.91	11.95	13.80	15.43	17.25	18.89	20.41
HF	20-1/2	16.23	18.74	20.95	23.42	25.65	27.71	16.06	18.54	20.73	23.18	25.39	27.42	15.67	18.10	20.24	22.62	24.78	26.77

NOTE: Standard capacity is rated at 100°F liquid inlet and 40°F evap temperature; with 160 PSI pressure drop across TXV per ARI-750-2001. These ratings assume vapor free liquid entering the thermal expansion valve.

R-448A / R-449A (tons) balance ported valves - NXT-R, B Series and H Series (cont'd)

Valve type	Nom. rating	Evaporator temperature																	
		0°F						-20°F						-40°F					
		Pressure drop across valve (psi)						Pressure drop across valve (psi)						Pressure drop across valve (psi)					
		60	80	100	125	150	175	80	100	125	150	175	200	80	100	125	150	175	200
NXT-R	1/5	0.11	0.12	0.14	0.15	0.17	0.18	0.08	0.09	0.10	0.11	0.12	0.13	0.05	0.06	0.07	0.07	0.08	0.08
NXT-R	1/4	0.28	0.32	0.36	0.40	0.43	0.47	0.21	0.24	0.27	0.29	0.31	0.34	0.14	0.15	0.17	0.19	0.20	0.22
NXT-R	1/2	0.46	0.53	0.59	0.66	0.72	0.78	0.35	0.40	0.44	0.49	0.52	0.56	0.23	0.25	0.28	0.31	0.34	0.36
NXT-R	1	0.61	0.71	0.79	0.89	0.97	1.05	0.48	0.53	0.59	0.65	0.70	0.75	0.30	0.34	0.38	0.42	0.45	0.48
NXT-R	1 1/2	1.10	1.27	1.42	1.59	1.74	1.88	0.85	0.95	1.06	1.17	1.26	1.35	0.54	0.61	0.68	0.75	0.81	0.86
NXT-R	2	1.47	1.69	1.89	2.12	2.32	2.51	1.14	1.27	1.42	1.56	1.68	1.80	0.73	0.81	0.91	0.99	1.07	1.15
NXT-R	2 1/2	1.95	2.26	2.52	2.82	3.09	3.34	1.51	1.69	1.89	2.07	2.24	2.39	0.97	1.08	1.21	1.32	1.43	1.53
NXT-R	3	2.19	2.52	2.82	3.16	3.46	3.73	1.69	1.89	2.12	2.32	2.50	2.68	1.08	1.21	1.35	1.48	1.60	1.71
NXT-R	3 1/2	2.85	3.29	3.68	4.11	4.51	4.87	2.21	2.47	2.76	3.02	3.26	3.49	1.41	1.58	1.76	1.93	2.09	2.23
NXT-R	4	3.15	3.64	4.07	4.55	4.98	5.38	2.44	2.73	3.05	3.34	3.61	3.86	1.56	1.74	1.95	2.14	2.31	2.47
NXT-R	5	3.56	4.11	4.60	5.14	5.63	6.08	2.76	3.08	3.45	3.78	4.08	4.36	1.76	1.97	2.20	2.41	2.61	2.79
NXT-R	5 1/2	3.85	4.45	4.97	5.56	6.09	6.58	2.98	3.33	3.73	4.08	4.41	4.71	1.91	2.13	2.38	2.61	2.82	3.01
NXT-R	6	4.51	5.21	5.83	6.51	7.14	7.71	3.49	3.91	4.37	4.79	5.17	5.53	2.23	2.50	2.79	3.06	3.30	3.53
BA/BN	1/2	0.38	0.44	0.49	0.54	0.60	0.64	0.34	0.39	0.43	0.47	0.51	0.54	0.23	0.26	0.29	0.32	0.34	0.37
BA/BN	1	0.72	0.83	0.93	1.03	1.13	1.22	0.65	0.73	0.82	0.90	0.97	1.04	0.44	0.49	0.55	0.61	0.65	0.70
BA/BN	1-1/2	1.12	1.29	1.44	1.61	1.77	1.91	1.02	1.14	1.27	1.40	1.51	1.61	0.69	0.77	0.86	0.94	1.02	1.09
BA/BN	2	1.49	1.73	1.93	2.16	2.36	2.55	1.36	1.53	1.71	1.87	2.02	2.16	0.92	1.03	1.15	1.26	1.36	1.46
BA/BN	2-1/2	1.89	2.18	2.44	2.72	2.98	3.22	1.72	1.93	2.15	2.36	2.55	2.72	1.16	1.30	1.45	1.59	1.72	1.84
BA/BN	3	2.29	2.64	2.95	3.30	3.62	3.91	2.09	2.33	2.61	2.86	3.09	3.30	1.41	1.58	1.76	1.93	2.09	2.23
BA/BN	4	2.96	3.42	3.82	4.27	4.68	5.05	2.70	3.02	3.38	3.70	4.00	4.27	1.82	2.04	2.28	2.50	2.70	2.88
BA/BN	5	3.75	4.33	4.84	5.41	5.93	6.41	3.43	3.83	4.28	4.69	5.07	5.42	2.31	2.59	2.89	3.17	3.42	3.66
BA/BN	6	4.66	5.38	6.01	6.72	7.36	7.95	4.25	4.75	5.32	5.82	6.29	6.72	2.87	3.21	3.59	3.93	4.25	4.54
HF	1/4	0.21	0.24	0.27	0.31	0.33	0.36	0.19	0.22	0.24	0.26	0.29	0.31	0.13	0.15	0.16	0.18	0.19	0.21
HF	1/2	0.40	0.46	0.52	0.58	0.63	0.68	0.37	0.41	0.46	0.50	0.54	0.58	0.25	0.28	0.31	0.34	0.36	0.39
HF	1	0.72	0.83	0.93	1.03	1.13	1.22	0.65	0.73	0.82	0.90	0.97	1.04	0.44	0.49	0.55	0.61	0.65	0.70
HF	1-1/2	1.09	1.26	1.41	1.58	1.73	1.87	1.00	1.12	1.25	1.37	1.48	1.58	0.67	0.75	0.84	0.92	1.00	1.07
HF	2	1.48	1.71	1.91	2.14	2.34	2.53	1.35	1.51	1.69	1.85	2.00	2.14	0.91	1.02	1.14	1.25	1.35	1.44
HF	2-1/2	1.89	2.19	2.45	2.73	3.00	3.24	1.73	1.93	2.16	2.37	2.56	2.74	1.17	1.31	1.46	1.60	1.73	1.85
HF	3-1/2	2.50	2.88	3.23	3.61	3.95	4.27	2.28	2.55	2.85	3.12	3.37	3.61	1.54	1.72	1.93	2.11	2.28	2.44
HF	6	4.45	5.13	5.74	6.42	7.03	7.59	4.06	4.54	5.07	5.56	6.00	6.42	2.74	3.06	3.43	3.75	4.05	4.33
HF	8-1/2	6.18	7.14	7.98	8.92	9.77	10.56	5.64	6.31	7.06	7.73	8.35	8.92	3.81	4.26	4.76	5.22	5.64	6.03
HF	10-1/2	7.85	9.06	10.13	11.33	12.41	13.41	7.17	8.01	8.96	9.81	10.60	11.33	4.84	5.41	6.05	6.63	7.16	7.65
HF	16	11.62	13.42	15.01	16.78	18.38	19.85	10.61	11.87	13.27	14.53	15.70	16.78	7.17	8.01	8.96	9.81	10.60	11.33
HF	20-1/2	15.25	17.61	19.68	22.01	24.11	26.04	13.92	15.56	17.40	19.06	20.59	22.01	9.40	10.51	11.75	12.87	13.90	14.86

Refrigerant liquid temperature correction factors

	Refrigerant liquid temperature °F															
	0	10	20	30	40	50	60	70	80	90	100	110	120	130	140	
R-448A/R-449A	1.71	1.64	1.57	1.50	1.43	1.36	1.29	1.22	1.15	1.07	1.00	0.92	0.85	0.77	0.69	

NOTE: These factors include corrections for liquid refrigerant density and net refrigeration effect, and are based on an average evaporator temperature of 0°F with a maximum 7°F Change in Superheat. However, they may be used for any evaporator temperature from -40°F to +40°F since the variation in the actual factors across this range is insignificant.

R-450A/R-513A balance ported valves (tons) NXT-R / B / HF Series

Valve type	Nom. rating	Evaporator temperature																	
		50°F						40°F						20°F					
		Pressure drop across valve (psi)						Pressure drop across valve (psi)						Pressure drop across valve (psi)					
		60	80	100	125	150	175	60	80	100	125	150	175	60	80	100	125	150	175
NXT-R	1/8	0.02	0.03	0.03	0.03	0.03	0.04	0.02	0.02	0.03	0.03	0.03	0.04	0.02	0.02	0.02	0.03	0.03	0.03
NXT-R	1/5	0.05	0.06	0.07	0.08	0.09	0.09	0.05	0.06	0.07	0.08	0.08	0.09	0.04	0.05	0.06	0.06	0.07	0.07
NXT-R	1/4	0.14	0.16	0.18	0.21	0.23	0.24	0.14	0.16	0.18	0.20	0.22	0.24	0.11	0.13	0.15	0.16	0.18	0.19
NXT-R	1/2	0.24	0.27	0.31	0.34	0.38	0.41	0.23	0.27	0.30	0.33	0.37	0.40	0.19	0.22	0.24	0.27	0.30	0.32
NXT-R	3/4	0.32	0.37	0.41	0.46	0.50	0.54	0.31	0.36	0.40	0.45	0.49	0.53	0.25	0.29	0.33	0.36	0.40	0.43
NXT-R	1	0.57	0.66	0.74	0.82	0.90	0.97	0.56	0.64	0.72	0.80	0.88	0.95	0.45	0.52	0.58	0.65	0.72	0.77
NXT-R	1 1/2	0.76	0.88	0.98	1.10	1.20	1.30	0.74	0.86	0.96	1.07	1.17	1.27	0.60	0.70	0.78	0.87	0.95	1.03
NXT-R	2	1.01	1.17	1.31	1.46	1.60	1.73	0.99	1.14	1.27	1.42	1.56	1.69	0.80	0.93	1.04	1.16	1.27	1.37
NXT-R	2 1/2	1.13	1.31	1.46	1.64	1.79	1.94	1.10	1.28	1.43	1.59	1.75	1.89	0.90	1.04	1.16	1.30	1.42	1.54
NXT-R	3	1.48	1.71	1.91	2.13	2.34	2.52	1.44	1.66	1.86	2.08	2.28	2.46	1.17	1.35	1.51	1.69	1.85	2.00
NXT-R	3 1/2	1.63	1.89	2.11	2.36	2.58	2.79	1.59	1.84	2.06	2.30	2.52	2.72	1.30	1.50	1.67	1.87	2.05	2.21
BA/BN	1/4	0.30	0.34	0.38	0.43	0.47	0.51	0.29	0.33	0.37	0.42	0.46	0.50	0.28	0.32	0.36	0.40	0.44	0.47
BA/BN	1/2	0.56	0.65	0.73	0.81	0.89	0.96	0.55	0.63	0.71	0.79	0.87	0.94	0.52	0.60	0.67	0.75	0.82	0.89
BA/BN	3/4	0.88	1.01	1.13	1.26	1.38	1.49	0.85	0.99	1.10	1.23	1.35	1.46	0.81	0.94	1.05	1.17	1.28	1.39
BA/BN	1	1.16	1.34	1.50	1.68	1.84	1.99	1.14	1.31	1.47	1.64	1.80	1.94	1.08	1.25	1.39	1.56	1.71	1.84
BA/BN	1-1/2	1.48	1.71	1.91	2.13	2.34	2.52	1.44	1.67	1.86	2.08	2.28	2.46	1.37	1.58	1.77	1.98	2.17	2.34
BA/BN	1-3/4	1.78	2.06	2.30	2.57	2.82	3.04	1.74	2.01	2.25	2.51	2.75	2.97	1.65	1.91	2.13	2.39	2.61	2.82
BA/BN	2-1/4	2.31	2.67	2.99	3.34	3.66	3.95	2.26	2.61	2.91	3.26	3.57	3.85	2.14	2.48	2.77	3.10	3.39	3.66
BA/BN	3	2.92	3.37	3.77	4.22	4.62	4.99	2.85	3.29	3.68	4.12	4.51	4.87	2.71	3.13	3.50	3.91	4.29	4.63
BA/BN	3-1/2	3.64	4.20	4.70	5.25	5.75	6.21	3.55	4.10	4.58	5.12	5.61	6.06	3.37	3.89	4.35	4.87	5.33	5.76
HF	1/5	0.17	0.19	0.22	0.24	0.27	0.29	0.16	0.19	0.21	0.24	0.26	0.28	0.16	0.18	0.20	0.23	0.25	0.27
HF	1/4	0.31	0.36	0.40	0.45	0.50	0.53	0.31	0.35	0.39	0.44	0.48	0.52	0.29	0.34	0.37	0.42	0.46	0.50
HF	1/2	0.56	0.65	0.73	0.81	0.89	0.96	0.55	0.63	0.71	0.79	0.87	0.94	0.52	0.60	0.67	0.75	0.82	0.89
HF	3/4	0.85	0.98	1.10	1.23	1.35	1.45	0.83	0.96	1.07	1.20	1.31	1.42	0.79	0.91	1.02	1.14	1.25	1.35
HF	1	1.15	1.33	1.48	1.66	1.82	1.96	1.12	1.29	1.45	1.62	1.77	1.91	1.06	1.23	1.37	1.54	1.68	1.82
HF	1-1/2	1.48	1.71	1.91	2.13	2.34	2.52	1.44	1.67	1.86	2.08	2.28	2.46	1.37	1.58	1.77	1.98	2.17	2.34
HF	2	1.94	2.24	2.51	2.80	3.07	3.32	1.90	2.19	2.45	2.74	3.00	3.24	1.80	2.08	2.33	2.60	2.85	3.08
HF	3-1/2	3.46	4.00	4.47	4.99	5.47	5.91	3.38	3.90	4.36	4.88	5.34	5.77	3.21	3.71	4.14	4.63	5.07	5.48
HF	4-1/2	4.82	5.56	6.22	6.95	7.62	8.23	4.70	5.43	6.07	6.79	7.44	8.03	4.47	5.16	5.77	6.45	7.06	7.63
HF	6	6.09	7.04	7.87	8.80	9.63	10.41	5.95	6.87	7.68	8.59	9.41	10.16	5.65	6.53	7.30	8.16	8.94	9.65
HF	9	9.04	10.44	11.67	13.05	14.29	15.44	8.82	10.19	11.39	12.74	13.95	15.07	8.38	9.68	10.82	12.10	13.26	14.32
HF	11-1/2	11.90	13.74	15.36	17.17	18.81	20.32	11.61	13.41	14.99	16.76	18.36	19.84	11.03	12.74	14.25	15.93	17.45	18.84

NOTE: Standard capacity is rate at 100F liquid inlet and 40°F evaporator temperature; with 60 PSI pressure drop across the TXV.

R-450A/R-513A balance ported valves (tons) NXT-R / B / HF Series (cont'd)

Valve type	Nom. rating	Evaporator temperature																	
		0°F						-20°F						-40°F					
		Pressure drop across valve (psi)						Pressure drop across valve (psi)						Pressure drop across valve (psi)					
		60	80	100	125	150	175	80	100	125	150	175	200	80	100	125	150	175	200
NXT-R	1/8	0.01	0.01	0.02	0.02	0.02	0.02	0.01	0.01	0.01	0.01	0.01	0.01	0.01	0.01	0.01	0.01	0.01	0.01
NXT-R	1/5	0.03	0.03	0.04	0.04	0.05	0.05	0.02	0.02	0.03	0.03	0.03	0.04	0.01	0.02	0.02	0.02	0.02	0.02
NXT-R	1/4	0.08	0.09	0.10	0.11	0.12	0.13	0.06	0.06	0.07	0.08	0.09	0.09	0.04	0.04	0.04	0.05	0.05	0.06
NXT-R	1/2	0.13	0.15	0.17	0.19	0.20	0.22	0.10	0.11	0.12	0.13	0.14	0.15	0.06	0.07	0.07	0.08	0.09	0.09
NXT-R	3/4	0.17	0.20	0.22	0.25	0.27	0.29	0.13	0.14	0.16	0.18	0.19	0.20	0.08	0.09	0.10	0.11	0.12	0.13
NXT-R	1	0.31	0.36	0.40	0.44	0.49	0.53	0.23	0.26	0.29	0.32	0.34	0.37	0.14	0.16	0.18	0.20	0.21	0.23
NXT-R	1 1/2	0.41	0.47	0.53	0.59	0.65	0.70	0.31	0.35	0.39	0.42	0.46	0.49	0.19	0.21	0.24	0.26	0.28	0.30
NXT-R	2	0.55	0.63	0.71	0.79	0.86	0.93	0.41	0.46	0.51	0.56	0.61	0.65	0.26	0.29	0.32	0.35	0.38	0.40
NXT-R	2 1/2	0.61	0.71	0.79	0.88	0.97	1.05	0.46	0.52	0.58	0.63	0.68	0.73	0.29	0.32	0.36	0.39	0.42	0.45
NXT-R	3	0.80	0.92	1.03	1.15	1.26	1.36	0.60	0.67	0.75	0.82	0.89	0.95	0.37	0.42	0.47	0.51	0.55	0.59
NXT-R	3 1/2	0.88	1.02	1.14	1.27	1.40	1.51	0.66	0.74	0.83	0.91	0.98	1.05	0.41	0.46	0.51	0.56	0.61	0.65
BA/BN	1/4	0.20	0.23	0.26	0.29	0.32	0.34	0.15	0.17	0.19	0.21	0.22	0.24	0.09	0.10	0.11	0.12	0.13	0.14
BA/BN	1/2	0.38	0.44	0.49	0.55	0.60	0.65	0.29	0.32	0.36	0.39	0.42	0.45	0.16	0.18	0.20	0.22	0.24	0.26
BA/BN	3/4	0.59	0.68	0.76	0.85	0.93	1.01	0.45	0.50	0.56	0.61	0.66	0.71	0.25	0.28	0.32	0.35	0.38	0.40
BA/BN	1	0.78	0.90	1.01	1.13	1.24	1.34	0.59	0.66	0.74	0.81	0.88	0.94	0.34	0.38	0.42	0.46	0.50	0.54
BA/BN	1-1/2	0.99	1.15	1.28	1.44	1.57	1.70	0.75	0.84	0.94	1.03	1.11	1.19	0.43	0.48	0.54	0.59	0.64	0.68
BA/BN	1-3/4	1.20	1.39	1.55	1.73	1.90	2.05	0.91	1.02	1.14	1.25	1.35	1.44	0.52	0.58	0.65	0.71	0.77	0.82
BA/BN	2-1/4	1.56	1.80	2.01	2.25	2.46	2.66	1.18	1.32	1.47	1.62	1.74	1.87	0.67	0.75	0.84	0.92	1.00	1.06
BA/BN	3	1.97	2.27	2.54	2.84	3.11	3.36	1.49	1.67	1.86	2.04	2.21	2.36	0.85	0.95	1.06	1.17	1.26	1.35
BA/BN	3-1/2	2.45	2.83	3.16	3.53	3.87	4.18	1.86	2.07	2.32	2.54	2.74	2.93	1.06	1.18	1.32	1.45	1.57	1.67
HF	1/5	0.11	0.13	0.15	0.16	0.18	0.19	0.09	0.10	0.11	0.12	0.13	0.14	0.05	0.05	0.06	0.07	0.07	0.08
HF	1/4	0.21	0.24	0.27	0.30	0.33	0.36	0.16	0.18	0.20	0.22	0.24	0.25	0.09	0.10	0.11	0.12	0.13	0.14
HF	1/2	0.38	0.44	0.49	0.55	0.60	0.65	0.29	0.32	0.36	0.39	0.42	0.45	0.16	0.18	0.20	0.22	0.24	0.26
HF	3/4	0.57	0.66	0.74	0.83	0.91	0.98	0.43	0.49	0.54	0.59	0.64	0.69	0.25	0.28	0.31	0.34	0.37	0.39
HF	1	0.77	0.89	1.00	1.12	1.22	1.32	0.59	0.65	0.73	0.80	0.87	0.93	0.33	0.37	0.42	0.46	0.49	0.53
HF	1-1/2	0.99	1.15	1.28	1.44	1.57	1.70	0.75	0.84	0.94	1.03	1.11	1.19	0.43	0.48	0.54	0.59	0.64	0.68
HF	2	1.31	1.51	1.69	1.89	2.07	2.23	0.99	1.11	1.24	1.36	1.47	1.57	0.57	0.63	0.71	0.77	0.84	0.89
HF	3-1/2	2.33	2.69	3.01	3.36	3.68	3.98	1.77	1.97	2.21	2.42	2.61	2.79	1.01	1.13	1.26	1.38	1.49	1.59
HF	4-1/2	3.24	3.74	4.19	4.68	5.13	5.54	2.46	2.75	3.07	3.37	3.64	3.89	1.40	1.57	1.75	1.92	2.07	2.22
HF	6	4.10	4.74	5.30	5.92	6.49	7.01	3.11	3.48	3.89	4.26	4.60	4.92	1.77	1.98	2.22	2.43	2.62	2.81
HF	9	6.09	7.03	7.86	8.78	9.62	10.39	4.61	5.16	5.77	6.32	6.82	7.29	2.63	2.94	3.29	3.60	3.89	4.16
HF	11-1/2	8.01	9.25	10.34	11.56	12.66	13.68	6.07	6.79	7.59	8.31	8.98	9.60	3.46	3.87	4.33	4.74	5.12	5.48

Refrigerant liquid temperature correction factors

	Refrigerant liquid temperature °F															
	0	10	20	30	40	50	60	70	80	90	100	110	120	130	140	
R-450A/R-513A	1.73	1.65	1.58	1.51	1.44	1.36	1.29	1.22	1.15	1.07	1.00	0.93	0.85	0.78	0.70	

NOTE: These factors include corrections for liquid refrigerant density and net refrigerating effect and are based on an average evaporator temperature of 0°F. However, they may be used for any evaporator temperature from -40°F to +40°F since the variation in the actual factors across this range is insignificant.

R-452A (tons) balance ported valves - B Series and H Series

Valve type	Nom. rating	Evaporator temperature																	
		50°F						40°F						20°F					
		Pressure drop across valve (psi)						Pressure drop across valve (psi)						Pressure drop across valve (psi)					
		60	80	100	125	150	175	60	80	100	125	150	175	60	80	100	125	150	175
NXT-R	1/5	0.09	0.10	0.12	0.13	0.14	0.15	0.09	0.10	0.11	0.13	0.14	0.15	0.08	0.10	0.11	0.12	0.13	0.14
NXT-R	1/4	0.23	0.27	0.30	0.34	0.37	0.40	0.23	0.26	0.29	0.33	0.36	0.39	0.22	0.25	0.28	0.31	0.34	0.37
NXT-R	1/2	0.39	0.45	0.50	0.56	0.62	0.67	0.38	0.44	0.49	0.55	0.60	0.65	0.36	0.42	0.47	0.52	0.57	0.62
NXT-R	1	0.52	0.60	0.67	0.75	0.82	0.89	0.51	0.59	0.66	0.73	0.80	0.87	0.48	0.56	0.62	0.70	0.76	0.82
NXT-R	1 1/2	0.93	1.08	1.21	1.35	1.48	1.60	0.91	1.05	1.18	1.32	1.44	1.56	0.87	1.00	1.12	1.25	1.37	1.48
NXT-R	2	1.25	1.44	1.61	1.80	1.97	2.13	1.22	1.41	1.57	1.76	1.92	2.08	1.15	1.33	1.49	1.67	1.82	1.97
NXT-R	2 1/2	1.66	1.92	2.14	2.40	2.62	2.83	1.62	1.87	2.09	2.34	2.56	2.77	1.54	1.77	1.98	2.22	2.43	2.62
NXT-R	3	1.86	2.14	2.40	2.68	2.94	3.17	1.81	2.09	2.34	2.62	2.87	3.10	1.72	1.99	2.22	2.48	2.72	2.94
NXT-R	3 1/2	2.42	2.80	3.12	3.49	3.83	4.13	2.36	2.73	3.05	3.41	3.74	4.04	2.24	2.59	2.89	3.24	3.54	3.83
NXT-R	4	2.68	3.09	3.46	3.87	4.23	4.57	2.62	3.02	3.38	3.77	4.14	4.47	2.48	2.86	3.20	3.58	3.92	4.24
NXT-R	5	3.03	3.49	3.91	4.37	4.78	5.17	2.95	3.41	3.81	4.26	4.67	5.05	2.80	3.24	3.62	4.04	4.43	4.78
NXT-R	5 1/2	3.27	3.78	4.22	4.72	5.17	5.59	3.19	3.69	4.12	4.61	5.05	5.46	3.03	3.50	3.91	4.37	4.79	5.17
NXT-R	6	3.83	4.43	4.95	5.53	6.06	6.55	3.74	4.32	4.83	5.40	5.92	6.39	3.55	4.10	4.58	5.13	5.61	6.06
BA/BN	1/2	0.30	0.35	0.39	0.43	0.47	0.51	0.29	0.34	0.38	0.42	0.46	0.50	0.28	0.32	0.36	0.40	0.44	0.47
BA/BN	1	0.57	0.66	0.73	0.82	0.90	0.97	0.56	0.64	0.72	0.80	0.88	0.95	0.53	0.61	0.68	0.76	0.83	0.90
BA/BN	1-1/2	0.89	1.02	1.14	1.28	1.40	1.51	0.87	1.00	1.12	1.25	1.37	1.48	0.82	0.95	1.06	1.19	1.30	1.40
BA/BN	2	1.19	1.37	1.53	1.71	1.88	2.03	1.16	1.34	1.50	1.67	1.83	1.98	1.10	1.27	1.42	1.59	1.74	1.88
BA/BN	2-1/2	1.50	1.73	1.93	2.16	2.37	2.56	1.46	1.69	1.89	2.11	2.31	2.50	1.39	1.60	1.79	2.00	2.19	2.37
BA/BN	3	1.82	2.10	2.34	2.62	2.87	3.10	1.77	2.05	2.29	2.56	2.80	3.03	1.68	1.94	2.17	2.43	2.66	2.87
BA/BN	4	2.35	2.71	3.03	3.39	3.71	4.01	2.29	2.65	2.96	3.31	3.63	3.92	2.17	2.51	2.81	3.14	3.44	3.71
BA/BN	5	2.98	3.44	3.84	4.30	4.71	5.09	2.91	3.36	3.75	4.20	4.60	4.97	2.76	3.18	3.56	3.98	4.36	4.71
BA/BN	6	3.70	4.27	4.77	5.34	5.85	6.31	3.61	4.17	4.66	5.21	5.71	6.17	3.42	3.95	4.42	4.94	5.41	5.85
HF	1/4	0.17	0.19	0.22	0.24	0.27	0.29	0.16	0.19	0.21	0.24	0.26	0.28	0.16	0.18	0.20	0.22	0.25	0.27
HF	1/2	0.32	0.37	0.41	0.46	0.50	0.54	0.31	0.36	0.40	0.45	0.49	0.53	0.29	0.34	0.38	0.42	0.46	0.50
HF	1	0.57	0.66	0.73	0.82	0.90	0.97	0.56	0.64	0.72	0.80	0.88	0.95	0.53	0.61	0.68	0.76	0.83	0.90
HF	1-1/2	0.87	1.00	1.12	1.25	1.37	1.48	0.85	0.98	1.10	1.22	1.34	1.45	0.80	0.93	1.04	1.16	1.27	1.37
HF	2	1.17	1.36	1.52	1.70	1.86	2.01	1.15	1.32	1.48	1.66	1.81	1.96	1.09	1.26	1.40	1.57	1.72	1.86
HF	2-1/2	1.50	1.74	1.94	2.17	2.38	2.57	1.47	1.70	1.90	2.12	2.32	2.51	1.39	1.61	1.80	2.01	2.20	2.38
HF	3-1/2	1.98	2.29	2.56	2.86	3.14	3.39	1.94	2.24	2.50	2.80	3.06	3.31	1.84	2.12	2.37	2.65	2.90	3.14
HF	6	3.53	4.08	4.56	5.09	5.58	6.03	3.45	3.98	4.45	4.97	5.45	5.89	3.27	3.77	4.22	4.72	5.17	5.58
HF	8-1/2	4.91	5.67	6.34	7.08	7.76	8.38	4.79	5.53	6.19	6.92	7.58	8.18	4.54	5.25	5.87	6.56	7.18	7.76
HF	10-1/2	6.23	7.20	8.04	8.99	9.85	10.64	6.08	7.03	7.86	8.78	9.62	10.39	5.77	6.66	7.45	8.33	9.12	9.85
HF	16	9.23	10.65	11.91	13.32	14.59	15.76	9.01	10.40	11.63	13.01	14.25	15.39	8.54	9.87	11.03	12.33	13.51	14.59
HF	20-1/2	12.10	13.98	15.62	17.47	19.14	20.67	11.82	13.65	15.26	17.06	18.69	20.18	11.21	12.94	14.47	16.18	17.72	19.14

NOTE: Standard capacity is rated at 100F liquid inlet and 40F evaporator temperature; with 100 PSI pressure drop across the TXV.

R-452A (tons) balance ported valves - B Series and H Series (cont'd)

Valve type	Nom. rating	Evaporator temperature																	
		0°F						-20°F						-40°F					
		Pressure drop across valve (psi)						Pressure drop across valve (psi)						Pressure drop across valve (psi)					
		60	80	100	125	150	175	80	100	125	150	175	200	80	100	125	150	175	200
NXT-R	1/5	0.08	0.09	0.10	0.11	0.12	0.13	0.06	0.07	0.08	0.09	0.09	0.10	0.04	0.05	0.05	0.06	0.06	0.06
NXT-R	1/4	0.20	0.24	0.26	0.29	0.32	0.35	0.16	0.18	0.21	0.23	0.24	0.26	0.11	0.12	0.13	0.14	0.16	0.17
NXT-R	1/2	0.34	0.39	0.44	0.49	0.54	0.58	0.27	0.31	0.34	0.38	0.41	0.43	0.18	0.20	0.22	0.24	0.26	0.28
NXT-R	1	0.45	0.52	0.59	0.66	0.72	0.78	0.37	0.41	0.46	0.50	0.54	0.58	0.23	0.26	0.29	0.32	0.35	0.37
NXT-R	1 1/2	0.82	0.94	1.05	1.18	1.29	1.39	0.66	0.74	0.82	0.90	0.98	1.04	0.42	0.47	0.53	0.58	0.62	0.66
NXT-R	2	1.09	1.25	1.40	1.57	1.72	1.86	0.88	0.98	1.10	1.20	1.30	1.39	0.56	0.63	0.70	0.77	0.83	0.89
NXT-R	2 1/2	1.45	1.67	1.87	2.09	2.29	2.47	1.17	1.31	1.46	1.60	1.73	1.85	0.75	0.83	0.93	1.02	1.10	1.18
NXT-R	3	1.62	1.87	2.09	2.34	2.56	2.77	1.31	1.47	1.64	1.79	1.94	2.07	0.83	0.93	1.04	1.14	1.23	1.32
NXT-R	3 1/2	2.11	2.44	2.73	3.05	3.34	3.61	1.71	1.91	2.13	2.34	2.53	2.70	1.09	1.22	1.36	1.49	1.61	1.72
NXT-R	4	2.34	2.70	3.02	3.37	3.69	3.99	1.89	2.11	2.36	2.59	2.80	2.99	1.20	1.35	1.50	1.65	1.78	1.90
NXT-R	5	2.64	3.05	3.41	3.81	4.17	4.51	2.13	2.39	2.67	2.92	3.16	3.38	1.36	1.52	1.70	1.86	2.01	2.15
NXT-R	5 1/2	2.85	3.29	3.68	4.12	4.51	4.87	2.31	2.58	2.89	3.16	3.41	3.65	1.47	1.64	1.84	2.01	2.17	2.32
NXT-R	6	3.34	3.86	4.32	4.83	5.29	5.71	2.71	3.03	3.38	3.70	4.00	4.28	1.72	1.93	2.15	2.36	2.55	2.72
BA/BN	1/2	0.26	0.30	0.34	0.38	0.41	0.45	0.21	0.24	0.26	0.29	0.31	0.33	0.13	0.15	0.17	0.18	0.20	0.21
BA/BN	1	0.50	0.57	0.64	0.72	0.78	0.85	0.40	0.45	0.50	0.55	0.59	0.64	0.26	0.29	0.32	0.35	0.38	0.40
BA/BN	1-1/2	0.77	0.89	1.00	1.12	1.22	1.32	0.63	0.70	0.78	0.86	0.93	0.99	0.40	0.45	0.50	0.55	0.59	0.63
BA/BN	2	1.03	1.19	1.34	1.49	1.64	1.77	0.84	0.94	1.05	1.15	1.24	1.32	0.53	0.60	0.67	0.73	0.79	0.84
BA/BN	2-1/2	1.31	1.51	1.69	1.89	2.07	2.23	1.06	1.18	1.32	1.45	1.56	1.67	0.67	0.75	0.84	0.92	1.00	1.06
BA/BN	3	1.58	1.83	2.04	2.29	2.50	2.70	1.28	1.43	1.60	1.75	1.89	2.03	0.82	0.91	1.02	1.12	1.21	1.29
BA/BN	4	2.05	2.37	2.64	2.96	3.24	3.50	1.66	1.85	2.07	2.27	2.45	2.62	1.06	1.18	1.32	1.45	1.56	1.67
BA/BN	5	2.60	3.00	3.35	3.75	4.11	4.44	2.10	2.35	2.63	2.88	3.11	3.32	1.34	1.50	1.67	1.83	1.98	2.12
BA/BN	6	3.22	3.72	4.16	4.65	5.10	5.51	2.61	2.92	3.26	3.57	3.86	4.12	1.66	1.86	2.08	2.27	2.46	2.63
HF	1/4	0.15	0.17	0.19	0.21	0.23	0.25	0.12	0.13	0.15	0.16	0.18	0.19	0.08	0.08	0.09	0.10	0.11	0.12
HF	1/2	0.28	0.32	0.36	0.40	0.44	0.47	0.22	0.25	0.28	0.31	0.33	0.35	0.14	0.16	0.18	0.20	0.21	0.23
HF	1	0.50	0.57	0.64	0.72	0.78	0.85	0.40	0.45	0.50	0.55	0.59	0.64	0.26	0.29	0.32	0.35	0.38	0.40
HF	1-1/2	0.76	0.87	0.98	1.09	1.20	1.29	0.61	0.69	0.77	0.84	0.91	0.97	0.39	0.44	0.49	0.53	0.58	0.62
HF	2	1.02	1.18	1.32	1.48	1.62	1.75	0.83	0.93	1.04	1.13	1.23	1.31	0.53	0.59	0.66	0.72	0.78	0.83
HF	2-1/2	1.31	1.51	1.69	1.89	2.07	2.24	1.06	1.19	1.33	1.45	1.57	1.68	0.68	0.76	0.84	0.93	1.00	1.07
HF	3-1/2	1.73	2.00	2.23	2.50	2.73	2.95	1.40	1.56	1.75	1.92	2.07	2.21	0.89	1.00	1.11	1.22	1.32	1.41
HF	6	3.08	3.55	3.97	4.44	4.87	5.26	2.49	2.78	3.11	3.41	3.68	3.94	1.59	1.77	1.98	2.17	2.35	2.51
HF	8-1/2	4.28	4.94	5.52	6.18	6.77	7.31	3.46	3.87	4.33	4.74	5.12	5.47	2.21	2.47	2.76	3.02	3.26	3.49
HF	10-1/2	5.43	6.27	7.02	7.84	8.59	9.28	4.40	4.92	5.50	6.02	6.50	6.95	2.80	3.13	3.50	3.83	4.14	4.43
HF	16	8.05	9.29	10.39	11.61	12.72	13.74	6.51	7.28	8.14	8.92	9.63	10.29	4.15	4.64	5.18	5.68	6.13	6.56
HF	20-1/2	10.55	12.19	13.63	15.23	16.69	18.03	8.54	9.55	10.67	11.69	12.63	13.50	5.44	6.08	6.80	7.45	8.04	8.60

Refrigerant liquid temperature correction factors

	Refrigerant liquid temperature °F															
	0	10	20	30	40	50	60	70	80	90	100	110	120	130	140	
R-452A	1.99	1.89	1.80	1.70	1.60	1.50	1.41	1.31	1.21	1.10	1.00	0.89	0.79	0.68	0.56	

NOTE: These factors include corrections for liquid refrigerant density and net refrigeration effect, and are based on an average evaporator temperature of 0°F with a maximum 7°F Change in Superheat. However, they may be used for any evaporator temperature from -40°F to +40°F since the variation in the actual factors across this range is insignificant.

R-452B balanced ported valves (tons) NXT Series

Valve type	Nom. rating	Evaporator temperature																					
		50 °F							40 °F							20 °F							
		Pressure drop across valve (psi)							Pressure drop across valve (psi)							Pressure drop across valve (psi)							
		75	110	140	160	210	240	285	75	110	140	160	210	240	285	75	110	140	160	210	240	285	
NXT Series	1/2	0.4	0.5	0.6	0.6	0.7	0.8	0.9	0.4	0.5	0.6	0.6	0.7	0.8	0.9	0.4	0.5	0.6	0.6	0.7	0.8	0.8	
	1	0.8	0.9	1.0	1.1	1.3	1.3	1.5	0.7	0.9	1.0	1.1	1.3	1.3	1.5	0.7	0.9	1.0	1.1	1.2	1.3	1.4	
	1-1/2	1.4	1.6	1.9	2.0	2.3	2.4	2.7	1.4	1.6	1.8	2.0	2.3	2.4	2.6	1.3	1.6	1.8	1.9	2.2	2.4	2.6	
	2	1.8	2.2	2.5	2.6	3.0	3.2	3.5	1.8	2.2	2.5	2.6	3.0	3.2	3.5	1.8	2.1	2.4	2.6	3.0	3.2	3.4	
	2-1/2	2.4	2.9	3.3	3.5	4.0	4.3	4.7	2.4	2.9	3.3	3.5	4.0	4.3	4.7	2.4	2.9	3.2	3.4	3.9	4.2	4.6	
	3	2.7	3.3	3.7	4.0	4.5	4.8	5.3	2.7	3.3	3.7	3.9	4.5	4.8	5.2	2.6	3.2	3.6	3.9	4.4	4.7	5.1	
	4	3.5	4.3	4.8	5.2	5.9	6.3	6.9	3.5	4.2	4.8	5.1	5.9	6.3	6.8	3.4	4.2	4.7	5.0	5.8	6.2	6.7	
	5	3.9	4.7	5.3	5.7	6.5	7.0	7.6	3.9	4.7	5.3	5.7	6.5	6.9	7.5	3.8	4.6	5.2	5.5	6.4	6.8	7.4	
	6	4.4	5.3	6.0	6.4	7.4	7.9	8.6	4.4	5.3	6.0	6.4	7.3	7.8	8.5	4.3	5.2	5.9	6.3	7.2	7.7	8.4	
	7	4.8	5.8	6.5	7.0	8.0	8.5	9.3	4.7	5.7	6.5	6.9	7.9	8.5	9.2	4.6	5.6	6.4	6.8	7.8	8.3	9.1	
	8	5.6	6.8	7.6	8.2	9.4	10.0	10.9	5.6	6.7	7.6	8.1	9.3	9.9	10.8	5.4	6.6	7.4	8.0	9.1	9.7	10.6	
	10	6.9	8.3	9.4	10.0	11.5	12.3	13.4	6.8	8.2	9.3	9.9	11.4	12.2	13.3	6.7	8.1	9.1	9.7	11.2	11.9	13.0	
	12	8.0	9.7	10.9	11.7	13.4	14.3	15.6	7.9	9.6	10.8	11.6	13.3	14.2	15.4	7.8	9.4	10.6	11.4	13.0	13.9	15.2	
	15	10.1	12.2	13.7	14.7	16.8	18.0	19.6	10.0	12.1	13.6	14.6	16.7	17.9	19.5	9.8	11.9	13.4	14.3	16.4	17.5	19.1	

Valve type	Nom. rating	Evaporator temperature																					
		0 °F							-20 °F							-40 °F							
		Pressure drop across valve (psi)							Pressure drop across valve (psi)							Pressure drop across valve (psi)							
		75	110	140	160	210	240	285	75	110	140	160	210	240	285	75	110	140	160	210	240	285	
NXT Series	1/2	0.4	0.5	0.6	0.6	0.7	0.8	0.8	0.4	0.5	0.6	0.6	0.7	0.7	0.8	0.3	0.3	0.4	0.4	0.5	0.5	0.5	
	1	0.7	0.9	1.0	1.0	1.2	1.3	1.4	0.7	0.8	0.9	1.0	1.1	1.2	1.3	0.5	0.6	0.6	0.7	0.8	0.8	0.9	
	1-1/2	1.3	1.6	1.8	1.9	2.2	2.3	2.5	1.2	1.5	1.7	1.8	2.1	2.2	2.4	0.8	1.0	1.1	1.2	1.4	1.5	1.6	
	2	1.7	2.1	2.4	2.5	2.9	3.1	3.4	1.6	2.0	2.3	2.4	2.8	3.0	3.2	1.1	1.3	1.5	1.6	1.9	2.0	2.2	
	2-1/2	2.3	2.8	3.1	3.4	3.9	4.1	4.5	2.2	2.7	3.0	3.2	3.7	3.9	4.3	1.5	1.8	2.0	2.2	2.5	2.7	2.9	
	3	2.6	3.1	3.5	3.8	4.3	4.6	5.0	2.5	3.0	3.4	3.6	4.1	4.4	4.8	1.7	2.0	2.3	2.4	2.8	3.0	3.2	
	4	3.4	4.1	4.6	4.9	5.6	6.0	6.5	3.2	3.9	4.4	4.7	5.4	5.7	6.3	2.2	2.6	3.0	3.2	3.6	3.9	4.2	
	5	3.7	4.5	5.1	5.4	6.2	6.6	7.2	3.5	4.3	4.8	5.2	5.9	6.3	6.9	2.4	2.9	3.3	3.5	4.0	4.3	4.7	
	6	4.2	5.1	5.7	6.1	7.0	7.5	8.2	4.0	4.9	5.5	5.9	6.7	7.2	7.8	2.7	3.3	3.7	3.9	4.5	4.8	5.3	
	7	4.5	5.5	6.2	6.6	7.6	8.1	8.9	4.3	5.3	5.9	6.3	7.3	7.8	8.5	2.9	3.5	4.0	4.3	4.9	5.2	5.7	
	8	5.3	6.4	7.3	7.8	8.9	9.5	10.4	5.1	6.2	7.0	7.4	8.5	9.1	9.9	3.4	4.1	4.7	5.0	5.7	6.1	6.7	
	10	6.5	7.9	8.9	9.5	10.9	11.7	12.7	6.2	7.6	8.5	9.1	10.4	11.2	12.2	4.2	5.1	5.7	6.1	7.0	7.5	8.2	
	12	7.6	9.2	10.4	11.1	12.7	13.6	14.8	7.3	8.8	9.9	10.6	12.2	13.0	14.2	4.9	5.9	6.7	7.1	8.2	8.7	9.5	
	15	9.6	11.6	13.1	14.0	16.0	17.1	18.7	9.2	11.1	12.5	13.4	15.3	16.4	17.8	6.2	7.5	8.4	9.0	10.3	11.0	12.0	

NOTE: Standard capacity is rated at 100°F liquid inlet and 40°F evap temperature; with 160 PSI pressure drop across TXV per ARI-7.50-2001. These ratings assume vapor free liquid entering the thermal expansion valve.

Refrigerant liquid temperature correction factors

	Refrigerant liquid temperature °F									
	50	60	70	80	90	100	110	120	130	140
R-452B	1.35	1.28	1.21	1.14	1.07	1.00	0.93	0.85	0.77	0.69

NOTE: These factors include corrections for liquid refrigerant density and net refrigeration effect, and are based on an average evaporator temperature of 0°F with a maximum 7°F Change in Superheat. However, they may be used for any evaporator temperature from -40°F to +40°F since the variation in the actual factors across this range is insignificant.

R-454A (tons) balance ported valves - NXT-R

Valve type	Nom. rating	Evaporator temperature																	
		50°F						40°F						20°F					
		Pressure drop across valve (psi)						Pressure drop across valve (psi)						Pressure drop across valve (psi)					
		60	80	100	125	150	175	60	80	100	125	150	175	60	80	100	125	150	175
NXT-R	1/10	0.05	0.06	0.06	0.07	0.08	0.08	0.05	0.05	0.06	0.07	0.07	0.08	0.05	0.05	0.06	0.07	0.07	0.08
NXT-R	1/5	0.12	0.14	0.16	0.17	0.19	0.21	0.12	0.14	0.15	0.17	0.19	0.20	0.11	0.13	0.15	0.16	0.18	0.19
NXT-R	1/2	0.31	0.36	0.40	0.45	0.49	0.53	0.31	0.36	0.40	0.44	0.49	0.53	0.30	0.34	0.38	0.43	0.47	0.51
NXT-R	3/4	0.52	0.60	0.67	0.75	0.82	0.89	0.51	0.59	0.66	0.74	0.81	0.88	0.49	0.57	0.64	0.71	0.78	0.84
NXT-R	1	0.70	0.81	0.90	1.01	1.10	1.19	0.69	0.79	0.89	0.99	1.09	1.17	0.66	0.76	0.85	0.95	1.05	1.13
NXT-R	1 1/2	1.25	1.45	1.62	1.81	1.98	2.14	1.23	1.42	1.59	1.78	1.95	2.10	1.19	1.37	1.53	1.71	1.88	2.03
NXT-R	2	1.67	1.93	2.15	2.41	2.64	2.85	1.64	1.90	2.12	2.37	2.60	2.80	1.58	1.83	2.04	2.28	2.50	2.70
NXT-R	2 1/2	2.22	2.57	2.87	3.21	3.51	3.80	2.19	2.52	2.82	3.16	3.46	3.73	2.11	2.43	2.72	3.04	3.33	3.60
NXT-R	3	2.49	2.87	3.21	3.59	3.93	4.25	2.45	2.82	3.16	3.53	3.87	4.18	2.36	2.72	3.04	3.40	3.73	4.03
NXT-R	4	3.24	3.74	4.19	4.68	5.13	5.54	3.19	3.68	4.12	4.60	5.04	5.44	3.07	3.55	3.97	4.43	4.86	5.25

NOTE: Standard capacity is rated at 100F liquid inlet and 40F evaporator temperature; with 100 Psi pressure drop across the TXV.

Valve type	Nom. rating	Evaporator temperature																	
		0°F						-20°F						-40°F					
		Pressure drop across valve (psi)						Pressure drop across valve (psi)						Pressure drop across valve (psi)					
		60	80	100	125	150	175	80	100	125	150	175	200	80	100	125	150	175	200
NXT-R	1/5	0.04	0.05	0.06	0.06	0.07	0.07	0.04	0.04	0.04	0.05	0.05	0.06	0.02	0.03	0.03	0.03	0.03	0.04
NXT-R	1/4	0.11	0.13	0.14	0.16	0.17	0.19	0.09	0.10	0.11	0.12	0.13	0.14	0.06	0.06	0.07	0.08	0.08	0.09
NXT-R	1/2	0.28	0.33	0.37	0.41	0.45	0.49	0.23	0.26	0.29	0.31	0.34	0.36	0.15	0.17	0.18	0.20	0.22	0.23
NXT-R	1	0.47	0.55	0.61	0.68	0.75	0.81	0.38	0.43	0.48	0.52	0.56	0.60	0.25	0.28	0.31	0.34	0.36	0.39
NXT-R	1 1/2	0.63	0.73	0.82	0.92	1.00	1.08	0.51	0.57	0.64	0.70	0.75	0.81	0.33	0.37	0.41	0.45	0.49	0.52
NXT-R	2	1.14	1.31	1.47	1.64	1.80	1.94	0.91	1.02	1.14	1.25	1.35	1.44	0.59	0.66	0.74	0.81	0.88	0.94
NXT-R	2 1/2	1.52	1.75	1.96	2.19	2.40	2.59	1.22	1.36	1.52	1.67	1.80	1.93	0.79	0.88	0.99	1.08	1.17	1.25
NXT-R	3	2.02	2.33	2.61	2.92	3.19	3.45	1.62	1.81	2.03	2.22	2.40	2.56	1.05	1.17	1.31	1.44	1.55	1.66
NXT-R	3 1/2	2.26	2.61	2.92	3.26	3.57	3.86	1.81	2.03	2.27	2.48	2.68	2.87	1.18	1.31	1.47	1.61	1.74	1.86
NXT-R	4	2.95	3.40	3.80	4.25	4.66	5.03	2.36	2.64	2.96	3.24	3.50	3.74	1.53	1.71	1.92	2.10	2.27	2.42

	Refrigerant liquid temperature °F															
	0	10	20	30	40	50	60	70	80	90	100	110	120	130	140	
R-454A	1.78	1.71	1.63	1.56	1.48	1.40	1.32	1.24	1.16	1.08	1.00	0.92	0.83	0.74	0.65	

NOTE: These factors include corrections for liquid refrigerant density and net refrigeration effect, and are based on an average evaporator temperature of 0°F with a maximum 7°F Change in Superheat. However, they may be used for any evaporator temperature from -40°F to +40°F since the variation in the actual factors across this range is insignificant.

R-454B balanced ported valves (tons) NXT Series

Valve type	Nom. rating	Evaporator temperature																				
		50 °F							40 °F							20 °F						
		Pressure drop across valve (psi)							Pressure drop across valve (psi)							Pressure drop across valve (psi)						
		75	110	140	160	210	240	285	75	110	140	160	210	240	285	75	110	140	160	210	240	285
NXT Series	1/2	0.4	0.5	0.6	0.6	0.7	0.8	0.9	0.4	0.5	0.6	0.6	0.7	0.8	0.9	0.4	0.5	0.6	0.6	0.7	0.8	0.8
	1	0.8	0.9	1.0	1.1	1.3	1.3	1.5	0.7	0.9	1.0	1.1	1.3	1.3	1.5	0.7	0.9	1.0	1.1	1.2	1.3	1.4
	1-1/2	1.4	1.6	1.9	2.0	2.3	2.4	2.6	1.3	1.6	1.8	2.0	2.3	2.4	2.6	1.3	1.6	1.8	1.9	2.2	2.4	2.6
	2	1.8	2.2	2.5	2.6	3.0	3.2	3.5	1.8	2.2	2.5	2.6	3.0	3.2	3.5	1.8	2.1	2.4	2.6	3.0	3.2	3.4
	2-1/2	2.4	2.9	3.3	3.5	4.0	4.3	4.7	2.4	2.9	3.3	3.5	4.0	4.3	4.7	2.4	2.9	3.2	3.4	3.9	4.2	4.6
	3	2.7	3.3	3.7	3.9	4.5	4.8	5.3	2.7	3.3	3.7	3.9	4.5	4.8	5.2	2.6	3.2	3.6	3.8	4.4	4.7	5.1
	4	3.5	4.3	4.8	5.1	5.9	6.3	6.9	3.5	4.2	4.8	5.1	5.9	6.3	6.8	3.4	4.2	4.7	5.0	5.7	6.1	6.7
	5	3.9	4.7	5.3	5.7	6.5	7.0	7.6	3.9	4.7	5.3	5.6	6.5	6.9	7.5	3.8	4.6	5.2	5.5	6.3	6.8	7.4
	6	4.4	5.3	6.0	6.4	7.4	7.9	8.6	4.4	5.3	6.0	6.4	7.3	7.8	8.5	4.3	5.2	5.9	6.3	7.2	7.7	8.4
	7	4.8	5.8	6.5	7.0	8.0	8.5	9.3	4.7	5.7	6.5	6.9	7.9	8.5	9.2	4.6	5.6	6.3	6.8	7.8	8.3	9.1
	8	5.6	6.8	7.6	8.2	9.3	10.0	10.9	5.5	6.7	7.6	8.1	9.3	9.9	10.8	5.4	6.6	7.4	7.9	9.1	9.7	10.6
	10	6.8	8.3	9.3	10.0	11.4	12.2	13.3	6.8	8.2	9.3	9.9	11.4	12.1	13.2	6.7	8.1	9.1	9.7	11.2	11.9	13.0
	12	8.0	9.7	10.9	11.6	13.3	14.3	15.5	7.9	9.6	10.8	11.6	13.2	14.2	15.4	7.8	9.4	10.6	11.3	13.0	13.9	15.1
15	10.0	12.2	13.7	14.7	16.8	18.0	19.6	10.0	12.1	13.6	14.6	16.7	17.8	19.4	9.8	11.8	13.4	14.3	16.4	17.5	19.1	

Valve type	Nom. rating	Evaporator temperature																				
		0°F							-40 °F							20 °F						
		Pressure drop across valve (psi)							Pressure drop across valve (psi)							Pressure drop across valve (psi)						
		75	110	140	160	210	240	285	75	110	140	160	210	240	285	75	110	140	160	210	240	285
NXT Series	1/2	0.4	0.5	0.6	0.6	0.7	0.8	0.8	0.4	0.5	0.5	0.6	0.7	0.7	0.8	0.3	0.3	0.4	0.4	0.4	0.5	0.5
	1	0.7	0.9	1.0	1.0	1.2	1.3	1.4	0.7	0.8	0.9	1.0	1.1	1.2	1.3	0.5	0.6	0.6	0.7	0.8	0.8	0.9
	1-1/2	1.3	1.6	1.8	1.9	2.2	2.3	2.5	1.2	1.5	1.7	1.8	2.0	2.2	2.4	0.8	1.0	1.1	1.2	1.4	1.5	1.6
	2	1.7	2.1	2.4	2.5	2.9	3.1	3.4	1.6	2.0	2.2	2.4	2.7	2.9	3.2	1.1	1.3	1.5	1.6	1.8	2.0	2.1
	2-1/2	2.3	2.8	3.1	3.4	3.8	4.1	4.5	2.2	2.6	3.0	3.2	3.6	3.9	4.2	1.5	1.8	2.0	2.1	2.4	2.6	2.8
	3	2.6	3.1	3.5	3.8	4.3	4.6	5.0	2.4	2.9	3.3	3.5	4.1	4.3	4.7	1.6	2.0	2.2	2.4	2.7	2.9	3.2
	4	3.4	4.1	4.6	4.9	5.6	6.0	6.5	3.2	3.8	4.3	4.6	5.3	5.7	6.2	2.1	2.6	2.9	3.1	3.6	3.8	4.1
	5	3.7	4.5	5.1	5.4	6.2	6.6	7.2	3.5	4.2	4.8	5.1	5.8	6.3	6.8	2.4	2.8	3.2	3.4	3.9	4.2	4.6
	6	4.2	5.1	5.7	6.1	7.0	7.5	8.2	4.0	4.8	5.4	5.8	6.6	7.1	7.7	2.7	3.2	3.6	3.9	4.5	4.8	5.2
	7	4.5	5.5	6.2	6.6	7.6	8.1	8.8	4.3	5.2	5.8	6.2	7.2	7.6	8.3	2.9	3.5	3.9	4.2	4.8	5.1	5.6
	8	5.3	6.4	7.3	7.8	8.9	9.5	10.4	5.0	6.1	6.8	7.3	8.4	9.0	9.8	3.4	4.1	4.6	4.9	5.6	6.0	6.6
	10	6.5	7.9	8.9	9.5	10.9	11.7	12.7	6.1	7.4	8.4	9.0	10.3	11.0	12.0	4.1	5.0	5.6	6.0	6.9	7.4	8.1
	12	7.6	9.2	10.4	11.1	12.7	13.6	14.8	7.2	8.7	9.8	10.4	12.0	12.8	13.9	4.8	5.8	6.6	7.0	8.1	8.6	9.4
15	9.6	11.6	13.1	14.0	16.0	17.1	18.6	9.0	10.9	12.3	13.2	15.1	16.1	17.6	6.1	7.3	8.3	8.9	10.1	10.8	11.8	

NOTE: Standard capacity is rated at 100°F liquid inlet and 40°F evap temperature; with 160 PSI pressure drop across TXV per ARI-7.50-2001. These ratings assume vapor free liquid entering the thermal expansion valve.

Refrigerant liquid temperature correction factors

	Refrigerant liquid temperature °F									
	50	60	70	80	90	100	110	120	130	140
R-454B	1.34	1.28	1.21	1.14	1.07	1.00	0.93	0.85	0.78	0.69

NOTE: These factors include corrections for liquid refrigerant density and net refrigeration effect, and are based on an average evaporator temperature of 0°F with a maximum 7°F Change in Superheat. However, they may be used for any evaporator temperature from -40°F to +40°F since the variation in the actual factors across this range is insignificant.

R-454C (tons) balance ported valves - NXT-R

Valve type	Nom. rating	Evaporator temperature																	
		50°F						40°F						20°F					
		Pressure drop across valve (psi)						Pressure drop across valve (psi)						Pressure drop across valve (psi)					
		60	80	100	125	150	175	60	80	100	125	150	175	60	80	100	125	150	175
NXT-R	1/10	0.04	0.05	0.05	0.06	0.06	0.07	0.04	0.04	0.05	0.06	0.06	0.07	0.04	0.04	0.05	0.05	0.06	0.06
NXT-R	1/5	0.10	0.11	0.13	0.14	0.16	0.17	0.10	0.11	0.13	0.14	0.15	0.17	0.09	0.11	0.12	0.13	0.15	0.16
NXT-R	1/2	0.26	0.30	0.33	0.37	0.41	0.44	0.25	0.29	0.33	0.37	0.40	0.43	0.24	0.28	0.31	0.35	0.38	0.41
NXT-R	3/4	0.43	0.50	0.56	0.62	0.68	0.74	0.42	0.49	0.54	0.61	0.67	0.72	0.40	0.46	0.52	0.58	0.64	0.69
NXT-R	1	0.58	0.67	0.74	0.83	0.91	0.99	0.56	0.65	0.73	0.81	0.89	0.96	0.54	0.62	0.69	0.78	0.85	0.92
NXT-R	1 1/2	1.03	1.19	1.34	1.49	1.64	1.77	1.01	1.17	1.31	1.46	1.60	1.73	0.97	1.11	1.25	1.39	1.53	1.65
NXT-R	2	1.38	1.59	1.78	1.99	2.18	2.36	1.35	1.56	1.74	1.95	2.13	2.30	1.29	1.49	1.66	1.86	2.03	2.20
NXT-R	2 1/2	1.84	2.12	2.37	2.65	2.90	3.14	1.80	2.07	2.32	2.59	2.84	3.07	1.71	1.98	2.21	2.47	2.71	2.93
NXT-R	3	2.06	2.37	2.65	2.97	3.25	3.51	2.01	2.32	2.60	2.90	3.18	3.43	1.92	2.21	2.48	2.77	3.03	3.28
NXT-R	4	2.68	3.09	3.46	3.87	4.24	4.57	2.62	3.03	3.38	3.78	4.14	4.48	2.50	2.89	3.23	3.61	3.95	4.27

NOTE: Standard capacity is rated at 100F liquid inlet and 40F evaporator temperature; with 100 Psi pressure drop across the TXV.

Valve type	Nom. rating	Evaporator temperature																	
		0°F						-20°F						-40°F					
		Pressure drop across valve (psi)						Pressure drop across valve (psi)						Pressure drop across valve (psi)					
		60	80	100	125	150	175	80	100	125	150	175	200	80	100	125	150	175	200
NXT-R	1/5	0.03	0.03	0.04	0.04	0.05	0.05	0.02	0.03	0.03	0.03	0.03	0.04	0.01	0.02	0.02	0.02	0.02	0.02
NXT-R	1/4	0.08	0.09	0.10	0.11	0.12	0.13	0.06	0.06	0.07	0.08	0.09	0.09	0.04	0.04	0.05	0.05	0.05	0.06
NXT-R	1/2	0.20	0.23	0.25	0.28	0.31	0.33	0.15	0.17	0.19	0.21	0.22	0.24	0.10	0.11	0.12	0.13	0.14	0.15
NXT-R	1	0.33	0.38	0.42	0.47	0.52	0.56	0.25	0.28	0.31	0.34	0.37	0.40	0.16	0.18	0.20	0.22	0.24	0.25
NXT-R	1 1/2	0.44	0.50	0.56	0.63	0.69	0.75	0.34	0.38	0.42	0.46	0.50	0.53	0.21	0.24	0.27	0.29	0.32	0.34
NXT-R	2	0.78	0.90	1.01	1.13	1.24	1.34	0.60	0.67	0.75	0.83	0.89	0.95	0.38	0.43	0.48	0.53	0.57	0.61
NXT-R	2 1/2	1.04	1.21	1.35	1.51	1.65	1.78	0.80	0.90	1.01	1.10	1.19	1.27	0.51	0.57	0.64	0.70	0.76	0.81
NXT-R	3	1.39	1.61	1.80	2.01	2.20	2.38	1.07	1.20	1.34	1.47	1.58	1.69	0.68	0.76	0.85	0.93	1.01	1.08
NXT-R	3 1/2	1.56	1.80	2.01	2.25	2.46	2.66	1.20	1.34	1.50	1.64	1.77	1.89	0.76	0.85	0.95	1.04	1.13	1.20
NXT-R	4	2.03	2.34	2.62	2.93	3.21	3.47	1.56	1.75	1.95	2.14	2.31	2.47	0.99	1.11	1.24	1.36	1.47	1.57

Refrigerant liquid temperature correction factors

	Refrigerant liquid temperature °F															
	0	10	20	30	40	50	60	70	80	90	100	110	120	130	140	
R-454C	1.83	1.75	1.67	1.59	1.51	1.42	1.34	1.26	1.17	1.09	1.00	0.91	0.82	0.73	0.64	

NOTE: These factors include corrections for liquid refrigerant density and net refrigeration effect, and are based on an average evaporator temperature of 0°F with a maximum 7°F Change in Superheat. However, they may be used for any evaporator temperature from -40°F to +40°F since the variation in the actual factors across this range is insignificant.

R-455a (tons) balance ported valves - NXT-R

Valve type	Nom. rating	Evaporator temperature																	
		50°F						40°F						20°F					
		Pressure drop across valve (psi)						Pressure drop across valve (psi)						Pressure drop across valve (psi)					
		60	80	100	125	150	175	60	80	100	125	150	175	60	80	100	125	150	175
NXT-R	1/10	0.05	0.05	0.06	0.07	0.07	0.08	0.05	0.05	0.06	0.07	0.07	0.08	0.04	0.05	0.06	0.06	0.07	0.07
NXT-R	1/5	0.12	0.13	0.15	0.17	0.18	0.20	0.11	0.13	0.15	0.16	0.18	0.19	0.11	0.12	0.14	0.16	0.17	0.18
NXT-R	1/2	0.30	0.35	0.39	0.43	0.47	0.51	0.29	0.34	0.38	0.42	0.46	0.50	0.28	0.32	0.36	0.40	0.44	0.48
NXT-R	3/4	0.50	0.58	0.65	0.72	0.79	0.85	0.49	0.57	0.63	0.71	0.77	0.84	0.47	0.54	0.60	0.67	0.74	0.80
NXT-R	1	0.67	0.77	0.86	0.97	1.06	1.14	0.66	0.76	0.85	0.95	1.04	1.12	0.63	0.72	0.81	0.90	0.99	1.07
NXT-R	1 1/2	1.20	1.39	1.55	1.73	1.90	2.05	1.17	1.36	1.52	1.70	1.86	2.01	1.12	1.30	1.45	1.62	1.77	1.92
NXT-R	2	1.60	1.85	2.07	2.31	2.53	2.73	1.57	1.81	2.02	2.26	2.48	2.68	1.50	1.73	1.93	2.16	2.37	2.56
NXT-R	2 1/2	2.13	2.46	2.75	3.08	3.37	3.64	2.09	2.41	2.69	3.01	3.30	3.56	1.99	2.30	2.57	2.88	3.15	3.40
NXT-R	3	2.38	2.75	3.08	3.44	3.77	4.07	2.33	2.70	3.01	3.37	3.69	3.99	2.23	2.58	2.88	3.22	3.53	3.81
NXT-R	4	3.11	3.59	4.01	4.49	4.91	5.31	3.04	3.51	3.93	4.39	4.81	5.20	2.91	3.36	3.75	4.19	4.60	4.96

NOTE: Standard capacity is rated at 100F liquid inlet and 40F evaporator temperature; with 100 Psi pressure drop across the TXV.

Valve type	Nom. rating	Evaporator temperature																	
		0°F						-20°F						-40°F					
		Pressure drop across valve (psi)						Pressure drop across valve (psi)						Pressure drop across valve (psi)					
		60	80	100	125	150	175	80	100	125	150	175	200	80	100	125	150	175	200
NXT-R	1/5	0.04	0.04	0.05	0.05	0.06	0.06	0.03	0.03	0.04	0.04	0.04	0.05	0.02	0.02	0.02	0.03	0.03	0.03
NXT-R	1/4	0.09	0.11	0.12	0.14	0.15	0.16	0.07	0.08	0.09	0.10	0.11	0.11	0.05	0.05	0.06	0.06	0.07	0.07
NXT-R	1/2	0.24	0.28	0.31	0.35	0.38	0.42	0.19	0.21	0.23	0.26	0.28	0.30	0.12	0.13	0.15	0.16	0.18	0.19
NXT-R	1	0.41	0.47	0.52	0.59	0.64	0.69	0.31	0.35	0.39	0.43	0.46	0.49	0.20	0.22	0.25	0.27	0.29	0.32
NXT-R	1 1/2	0.54	0.63	0.70	0.78	0.86	0.93	0.42	0.47	0.52	0.57	0.62	0.66	0.27	0.30	0.33	0.37	0.39	0.42
NXT-R	2	0.97	1.12	1.26	1.40	1.54	1.66	0.75	0.84	0.94	1.03	1.11	1.19	0.48	0.53	0.60	0.65	0.71	0.76
NXT-R	2 1/2	1.30	1.50	1.68	1.87	2.05	2.22	1.00	1.12	1.25	1.37	1.48	1.58	0.64	0.71	0.80	0.87	0.94	1.01
NXT-R	3	1.73	2.00	2.23	2.49	2.73	2.95	1.33	1.49	1.67	1.82	1.97	2.11	0.85	0.95	1.06	1.16	1.26	1.34
NXT-R	3 1/2	1.93	2.23	2.50	2.79	3.06	3.30	1.49	1.67	1.86	2.04	2.21	2.36	0.95	1.06	1.19	1.30	1.41	1.50
NXT-R	4	2.52	2.91	3.25	3.64	3.99	4.30	1.94	2.17	2.43	2.66	2.87	3.07	1.24	1.38	1.55	1.70	1.83	1.96

Refrigerant liquid temperature correction factors

	Refrigerant liquid temperature °F															
	0	10	20	30	40	50	60	70	80	90	100	110	120	130	140	
R-455A	1.83	1.75	1.67	1.59	1.51	1.42	1.34	1.26	1.17	1.09	1.00	0.91	0.82	0.73	0.64	

NOTE: These factors include corrections for liquid refrigerant density and net refrigeration effect, and are based on an average evaporator temperature of 0°F with a maximum 7°F Change in Superheat. However, they may be used for any evaporator temperature from -40°F to +40°F since the variation in the actual factors across this range is insignificant.

R-502 balanced ported valves (tons) NXT-R / B / HF / TFE / TRAE / T Series

Valve type	Nom. rating	Evaporator temperature																	
		50°F						40°F						20°F					
		Pressure drop across valve (psi)						Pressure drop across valve (psi)						Pressure drop across valve (psi)					
		60	80	100	125	150	175	60	80	100	125	150	175	60	80	100	125	150	175
NXT-R	1/8	0.21	0.24	0.27	0.30	0.33	0.36	0.20	0.24	0.26	0.30	0.32	0.35	0.20	0.23	0.25	0.28	0.31	0.33
NXT-R	1/4	0.35	0.40	0.45	0.50	0.55	0.59	0.34	0.39	0.44	0.49	0.54	0.58	0.33	0.38	0.42	0.47	0.51	0.56
NXT-R	1/2	0.47	0.54	0.60	0.67	0.74	0.80	0.46	0.53	0.59	0.66	0.72	0.78	0.44	0.50	0.56	0.63	0.69	0.74
NXT-R	1	0.84	0.96	1.08	1.21	1.32	1.43	0.82	0.94	1.06	1.18	1.29	1.40	0.78	0.90	1.01	1.13	1.23	1.33
NXT-R	1 1/4	1.11	1.29	1.44	1.61	1.76	1.90	1.09	1.26	1.41	1.57	1.72	1.86	1.04	1.20	1.34	1.50	1.65	1.78
NXT-R	1 1/2	1.48	1.71	1.91	2.14	2.34	2.53	1.45	1.68	1.87	2.10	2.30	2.48	1.39	1.60	1.79	2.00	2.19	2.37
NXT-R	2	1.66	1.92	2.14	2.40	2.62	2.83	1.62	1.88	2.10	2.35	2.57	2.77	1.55	1.79	2.00	2.24	2.45	2.65
NXT-R	2 1/2	2.16	2.50	2.79	3.12	3.42	3.69	2.12	2.45	2.73	3.06	3.35	3.62	2.02	2.33	2.61	2.92	3.20	3.45
NXT-R	3	2.39	2.76	3.09	3.45	3.78	4.09	2.34	2.71	3.02	3.38	3.70	4.00	2.24	2.58	2.89	3.23	3.54	3.82
NXT-R	4	3.43	3.96	4.42	4.95	5.42	5.85	3.35	3.87	4.33	4.84	5.30	5.73	3.20	3.70	4.14	4.62	5.06	5.47
BA/BN	1/4	0.26	0.30	0.34	0.38	0.41	0.44	0.25	0.29	0.32	0.36	0.40	0.43	0.24	0.28	0.31	0.35	0.38	0.41
BA/BN	1/2	0.49	0.57	0.63	0.71	0.77	0.84	0.48	0.55	0.62	0.69	0.76	0.82	0.46	0.53	0.59	0.66	0.73	0.79
BA/BN	1	0.76	0.88	0.98	1.10	1.20	1.30	0.74	0.85	0.96	1.07	1.17	1.26	0.71	0.82	0.92	1.02	1.12	1.21
BA/BN	1-1/4	1.02	1.18	1.32	1.47	1.61	1.74	0.99	1.14	1.28	1.43	1.57	1.69	0.95	1.10	1.23	1.37	1.50	1.62
BA/BN	1-1/2	1.28	1.48	1.65	1.85	2.02	2.19	1.26	1.45	1.63	1.82	1.99	2.15	1.20	1.39	1.55	1.73	1.90	2.05
BA/BN	2	1.55	1.79	2.00	2.24	2.45	2.65	1.52	1.76	1.96	2.19	2.40	2.60	1.45	1.67	1.87	2.09	2.29	2.48
BA/BN	2-1/2	2.01	2.32	2.59	2.90	3.18	3.43	1.97	2.27	2.54	2.84	3.11	3.36	1.88	2.17	2.43	2.71	2.97	3.21
BA/BN	3	2.54	2.93	3.28	3.67	4.02	4.34	2.49	2.88	3.21	3.59	3.94	4.25	2.38	2.75	3.07	3.44	3.76	4.06
BA/BN	4	3.17	3.66	4.09	4.58	5.01	5.41	3.10	3.58	4.00	4.47	4.90	5.29	2.96	3.42	3.82	4.27	4.68	5.06
HF	1/8	0.14	0.16	0.18	0.20	0.22	0.24	0.14	0.16	0.18	0.20	0.22	0.24	0.13	0.15	0.17	0.19	0.21	0.22
HF	1/4	0.27	0.31	0.35	0.39	0.43	0.46	0.27	0.31	0.35	0.39	0.43	0.46	0.25	0.29	0.32	0.36	0.40	0.43
HF	1/2	0.49	0.57	0.63	0.71	0.77	0.84	0.48	0.55	0.62	0.69	0.76	0.82	0.46	0.53	0.59	0.66	0.73	0.79
HF	1	0.74	0.85	0.96	1.07	1.17	1.26	0.73	0.84	0.94	1.05	1.15	1.25	0.70	0.81	0.90	1.01	1.11	1.20
HF	1-1/4	1.00	1.15	1.29	1.44	1.58	1.71	0.98	1.13	1.27	1.41	1.55	1.67	0.93	1.07	1.20	1.34	1.47	1.59
HF	1-1/2	1.28	1.48	1.65	1.85	2.02	2.19	1.26	1.45	1.63	1.82	1.99	2.15	1.20	1.39	1.55	1.73	1.90	2.05
HF	2	1.69	1.95	2.18	2.44	2.67	2.89	1.66	1.92	2.14	2.40	2.62	2.83	1.58	1.82	2.04	2.28	2.50	2.70
HF	3-1/2	3.01	3.48	3.89	4.34	4.76	5.14	2.95	3.41	3.81	4.26	4.66	5.04	2.81	3.24	3.63	4.06	4.44	4.80
HF	5	4.19	4.84	5.41	6.05	6.62	7.16	4.10	4.73	5.29	5.92	6.48	7.00	3.92	4.53	5.06	5.66	6.20	6.69
HF	7	5.30	6.12	6.84	7.65	8.38	9.05	5.19	5.99	6.70	7.49	8.21	8.86	4.96	5.73	6.40	7.16	7.84	8.47
HF	10	7.87	9.09	10.16	11.36	12.44	13.44	7.70	8.89	9.94	11.11	12.17	13.15	7.35	8.49	9.49	10.61	11.62	12.55
HF	13	10.36	11.96	13.37	14.95	16.38	17.69	10.14	11.71	13.09	14.64	16.03	17.32	9.68	11.18	12.50	13.97	15.31	16.53
TFE	5	4.11	4.75	5.31	5.93	6.50	7.02	4.03	4.65	5.20	5.82	6.37	6.88	3.84	4.43	4.96	5.54	6.07	6.56
TFE	7	5.63	6.50	7.27	8.13	8.90	9.62	5.51	6.36	7.11	7.95	8.71	9.41	5.26	6.07	6.79	7.59	8.32	8.98
TFE	9	6.99	8.07	9.02	10.09	11.05	11.94	6.85	7.91	8.84	9.89	10.83	11.70	6.53	7.54	8.43	9.43	10.32	11.15
TFE	14	10.68	12.33	13.79	15.42	16.89	18.24	10.45	12.07	13.49	15.08	16.52	17.85	9.97	11.51	12.87	14.39	15.76	17.03
TRAE+	8	6.05	6.99	7.81	8.73	9.57	10.33	5.93	6.85	7.66	8.56	9.38	10.13	5.66	6.54	7.31	8.17	8.95	9.67
TRAE+	12	8.82	10.18	11.39	12.73	13.95	15.06	8.64	9.98	11.15	12.47	13.66	14.76	8.24	9.51	10.64	11.89	13.03	14.07
TRAE+	14	9.85	11.37	12.72	14.22	15.57	16.82	9.64	11.13	12.45	13.91	15.24	16.46	9.20	10.62	11.88	13.28	14.55	15.71
TRAE+	20	14.93	17.24	19.27	21.55	23.61	25.50	14.61	16.87	18.86	21.09	23.10	24.95	13.95	16.11	18.01	20.14	22.06	23.82
TRAE+	30	20.52	23.69	26.49	29.62	32.44	35.04	20.09	23.20	25.94	29.00	31.77	34.31	19.17	22.14	24.75	27.67	30.31	32.74
TRAE	35	27.70	31.99	35.76	39.98	43.80	47.31	27.12	31.32	35.01	39.14	42.88	46.32	25.88	29.88	33.41	37.35	40.92	44.20
TRAE	40	30.22	34.90	39.01	43.62	47.78	51.61	29.58	34.16	38.19	42.70	46.77	50.52	28.23	32.60	36.44	40.75	44.64	48.21
TRAE	50	35.96	41.52	46.42	51.90	56.86	61.41	35.21	40.66	45.46	50.82	55.67	60.13	35.21	40.66	45.46	50.82	55.67	60.13
TJR	9	7.54	8.71	9.73	10.88	11.92	12.88	7.38	8.52	9.53	10.65	11.67	12.60	7.05	8.14	9.10	10.18	11.15	12.04
TJR	12	9.03	10.43	11.66	13.03	14.28	15.42	8.84	10.21	11.41	12.76	13.98	15.10	8.44	9.75	10.90	12.19	13.35	14.42
TER	14	11.29	13.04	14.58	16.30	17.85	19.28	11.05	12.76	14.27	15.95	17.47	18.87	10.56	12.19	13.63	15.24	16.70	18.03
TER	16	13.34	15.40	17.22	19.25	21.09	22.78	13.06	15.08	16.86	18.85	20.65	22.30	12.48	14.41	16.11	18.01	19.73	21.31
TER	21	17.96	20.74	23.19	25.92	28.40	30.67	17.58	20.30	22.70	25.37	27.80	30.02	16.80	19.39	21.68	24.24	26.56	28.69
TER	27	23.09	26.66	29.81	33.33	36.51	39.43	22.60	26.10	29.18	32.62	35.73	38.60	21.59	24.93	27.87	31.16	34.14	36.87
TIR	37	28.22	32.59	36.43	40.73	44.62	48.19	27.62	31.89	35.66	39.87	43.67	47.17	26.39	30.47	34.06	38.08	41.72	45.06
THR	48	35.91	41.47	46.36	51.83	56.78	61.33	35.15	40.59	45.38	50.73	55.58	60.03	33.58	38.77	43.35	48.47	53.09	57.35
THR	60	43.61	50.36	56.30	62.95	68.95	74.48	42.69	49.29	55.11	61.62	67.50	72.91	40.78	47.09	52.64	58.86	64.48	69.64
TMR	60	51.30	59.24	66.23	74.05	81.11	87.61	50.22	57.99	64.83	72.49	79.40	85.77	47.97	55.39	61.93	69.24	75.85	81.92

NOTE: Standard capacity is rated at 100°F liquid inlet and 40°F evaporator temperature; with 100 PSI pressure drop across the TXV per ARI 750-2001.

R-502 balanced ported valves (tons) NXT-R / B / HF / TFE / TRAE / T Series (cont'd)

Valve type	Nom. rating	Evaporator temperature																	
		0°F						-20°F						-40°F					
		Pressure drop across valve (psi)						Pressure drop across valve (psi)						Pressure drop across valve (psi)					
		60	80	100	125	150	175	80	100	125	150	175	200	80	100	125	150	175	200
NXT-R	1/8	0.19	0.21	0.24	0.27	0.29	0.32	0.15	0.17	0.19	0.21	0.22	0.24	0.10	0.11	0.12	0.14	0.15	0.16
NXT-R	1/4	0.31	0.36	0.40	0.45	0.49	0.53	0.25	0.28	0.32	0.35	0.37	0.40	0.17	0.19	0.21	0.23	0.25	0.26
NXT-R	1/2	0.41	0.48	0.53	0.60	0.65	0.71	0.34	0.38	0.42	0.46	0.50	0.54	0.22	0.25	0.28	0.31	0.33	0.35
NXT-R	1	0.74	0.86	0.96	1.07	1.17	1.27	0.61	0.68	0.76	0.83	0.90	0.96	0.40	0.45	0.50	0.55	0.59	0.63
NXT-R	1 1/4	0.99	1.14	1.28	1.43	1.56	1.69	0.81	0.90	1.01	1.11	1.20	1.28	0.53	0.60	0.67	0.73	0.79	0.84
NXT-R	1 1/2	1.32	1.52	1.70	1.90	2.08	2.25	1.08	1.20	1.35	1.48	1.59	1.70	0.71	0.79	0.89	0.97	1.05	1.12
NXT-R	2	1.47	1.70	1.90	2.13	2.33	2.52	1.21	1.35	1.51	1.65	1.78	1.91	0.79	0.89	0.99	1.09	1.18	1.26
NXT-R	2 1/2	1.92	2.22	2.48	2.77	3.04	3.28	1.57	1.76	1.96	2.15	2.32	2.48	1.04	1.16	1.29	1.42	1.53	1.64
NXT-R	3	2.12	2.45	2.74	3.07	3.36	3.63	1.74	1.94	2.17	2.38	2.57	2.75	1.15	1.28	1.43	1.57	1.69	1.81
NXT-R	4	3.04	3.51	3.93	4.39	4.81	5.19	2.49	2.78	3.11	3.41	3.68	3.94	1.64	1.83	2.05	2.25	2.43	2.59
BA/BN	1/4	0.22	0.25	0.28	0.32	0.35	0.38	0.17	0.19	0.21	0.23	0.25	0.27	0.11	0.12	0.14	0.15	0.16	0.17
BA/BN	1/2	0.42	0.48	0.54	0.61	0.66	0.72	0.33	0.37	0.41	0.45	0.49	0.52	0.21	0.23	0.26	0.29	0.31	0.33
BA/BN	1	0.65	0.75	0.84	0.94	1.03	1.11	0.52	0.58	0.65	0.71	0.77	0.82	0.33	0.37	0.41	0.45	0.49	0.52
BA/BN	1-1/4	0.87	1.00	1.12	1.26	1.38	1.49	0.69	0.77	0.86	0.94	1.02	1.09	0.44	0.49	0.55	0.60	0.65	0.70
BA/BN	1-1/2	1.10	1.27	1.42	1.59	1.74	1.88	0.87	0.97	1.09	1.19	1.29	1.38	0.55	0.61	0.69	0.75	0.81	0.87
BA/BN	2	1.34	1.55	1.73	1.93	2.12	2.29	1.05	1.17	1.31	1.44	1.55	1.66	0.67	0.75	0.84	0.92	0.99	1.06
BA/BN	2-1/2	1.73	2.00	2.23	2.50	2.74	2.95	1.36	1.52	1.70	1.86	2.01	2.15	0.87	0.97	1.09	1.19	1.29	1.38
BA/BN	3	2.19	2.53	2.83	3.16	3.46	3.74	1.73	1.93	2.16	2.37	2.56	2.74	1.10	1.23	1.38	1.51	1.63	1.74
BA/BN	4	2.72	3.14	3.51	3.93	4.30	4.65	2.15	2.40	2.69	2.94	3.18	3.40	1.37	1.53	1.71	1.88	2.03	2.17
HF	1/8	0.12	0.14	0.15	0.17	0.19	0.20	0.10	0.11	0.13	0.14	0.15	0.16	0.06	0.07	0.08	0.08	0.09	0.09
HF	1/4	0.23	0.27	0.30	0.33	0.36	0.39	0.18	0.20	0.23	0.25	0.27	0.28	0.12	0.13	0.15	0.16	0.18	0.19
HF	1/2	0.42	0.48	0.54	0.61	0.66	0.72	0.33	0.37	0.41	0.45	0.49	0.52	0.21	0.23	0.26	0.29	0.31	0.33
HF	1	0.64	0.74	0.83	0.92	1.01	1.09	0.50	0.56	0.63	0.68	0.74	0.79	0.32	0.36	0.40	0.44	0.47	0.51
HF	1-1/4	0.86	0.99	1.11	1.24	1.36	1.47	0.68	0.76	0.85	0.93	1.01	1.08	0.43	0.48	0.54	0.59	0.64	0.68
HF	1-1/2	1.10	1.27	1.42	1.59	1.74	1.88	0.87	0.97	1.09	1.19	1.29	1.38	0.55	0.61	0.69	0.75	0.81	0.87
HF	2	1.46	1.69	1.88	2.11	2.31	2.49	1.15	1.29	1.44	1.57	1.70	1.82	0.73	0.82	0.91	1.00	1.08	1.15
HF	3-1/2	2.59	2.99	3.34	3.74	4.10	4.42	1.65	1.84	2.06	2.26	2.44	2.61	1.30	1.45	1.63	1.78	1.92	2.06
HF	5	3.60	4.16	4.65	5.20	5.69	6.15	2.84	3.18	3.55	3.89	4.20	4.49	1.81	2.02	2.26	2.48	2.68	2.86
HF	7	4.56	5.27	5.89	6.58	7.21	7.79	3.60	4.02	4.50	4.93	5.32	5.69	2.29	2.56	2.86	3.14	3.39	3.62
HF	10	6.76	7.81	8.73	9.76	10.69	11.54	5.34	5.97	6.68	7.31	7.90	8.44	3.40	3.80	4.25	4.66	5.03	5.38
HF	13	8.90	10.28	11.49	12.85	14.07	15.20	7.03	7.86	8.79	9.63	10.40	11.12	4.48	5.01	5.60	6.13	6.63	7.08
TFE	5	3.54	4.09	4.57	5.11	5.60	6.05	2.79	3.12	3.49	3.82	4.13	4.41	1.78	1.99	2.23	2.44	2.63	2.81
TFE	7	4.84	5.59	6.25	6.99	7.65	8.27	3.82	4.27	4.78	5.23	5.65	6.04	2.43	2.72	3.04	3.33	3.59	3.84
TFE	9	6.01	6.94	7.76	8.67	9.50	10.26	4.75	5.31	5.94	6.50	7.03	7.51	3.02	3.38	3.78	4.14	4.47	4.78
TFE	14	9.18	10.60	11.85	13.25	14.51	15.68	7.25	8.11	9.06	9.93	10.72	11.46	4.61	5.15	5.76	6.31	6.82	7.29
TRAE+	8	5.20	6.00	6.71	7.51	8.22	8.88	4.11	4.60	5.14	5.63	6.08	6.50	2.62	2.93	3.28	3.59	3.88	4.14
TRAE+	12	7.58	8.75	9.79	10.94	11.99	12.95	5.99	6.70	7.49	8.20	8.86	9.47	3.81	4.26	4.76	5.22	5.64	6.02
TRAE+	14	8.47	9.78	10.93	12.23	13.39	14.47	6.69	7.48	8.36	9.16	9.89	10.58	4.26	4.76	5.33	5.83	6.30	6.74
TRAE+	20	12.83	14.81	16.56	18.52	20.29	21.91	10.13	11.33	12.66	13.87	14.98	16.02	6.45	7.21	8.06	8.83	9.54	10.20
TRAE+	30	17.64	20.37	22.77	25.46	27.89	30.13	13.93	15.57	17.41	19.07	20.60	22.03	8.87	9.92	11.09	12.15	13.12	14.02
TRAE	35	23.81	27.49	30.74	34.37	37.65	40.66	18.80	21.02	23.50	25.74	27.81	29.73	11.97	13.38	14.96	16.39	17.70	18.93
TRAE	40	25.97	29.99	33.53	37.48	41.06	44.35	20.51	22.93	25.64	28.08	30.33	32.43	13.06	14.60	16.33	17.88	19.32	20.65
TRAE	50	30.91	35.69	39.90	44.61	48.87	52.79	24.41	27.29	30.51	33.42	36.10	38.60	15.54	17.37	19.43	21.28	22.98	24.57
TJR	9	6.70	7.74	8.65	9.67	10.59	11.44	7.31	8.17	9.14	10.01	10.81	11.56	6.89	7.70	8.61	9.43	10.19	11.56
TJR	12	8.02	9.26	10.36	11.58	12.68	13.70	8.75	9.78	10.94	11.98	12.94	13.84	8.25	9.22	10.31	11.29	12.20	13.84
TER	14	10.03	11.58	12.95	14.48	15.86	17.13	10.95	12.24	13.68	14.99	16.19	17.31	10.31	11.53	12.89	14.12	15.26	17.31
TER	16	11.85	13.59	15.30	17.11	18.74	20.24	12.93	14.46	16.16	17.71	19.13	20.45	12.19	13.63	15.23	16.69	18.02	20.45
TER	21	15.96	18.43	20.60	23.03	25.23	27.26	17.14	19.47	21.76	23.84	25.75	27.53	16.41	18.35	20.51	22.47	24.27	27.53
TER	27	20.51	23.69	26.48	29.61	32.44	35.04	22.38	25.02	27.98	30.65	33.10	35.39	21.09	23.58	26.37	28.88	31.20	35.39
TIR	37	25.07	28.95	32.37	36.19	39.64	42.82	27.35	30.58	34.19	37.45	40.45	43.25	25.78	28.82	32.22	35.30	38.12	43.25
THR	48	31.90	36.84	41.19	46.05	50.44	54.49	34.81	38.92	43.51	47.66	51.48	55.04	32.80	36.67	41.00	44.92	48.52	55.04
THR	60	38.74	44.74	50.02	55.92	61.26	66.71	42.27	47.26	52.84	57.88	62.52	66.84	39.84	44.54	49.79	54.55	58.92	66.84
TMR	60	45.58	52.63	58.84	65.79	72.07	77.84	49.73	55.60	62.84	68.09	73.55	78.62	46.86	52.39	58.58	64.17	69.31	78.62

*Refrigerant liquid temperature correction factors*

	Refrigerant liquid temperature °F														
	0	10	20	30	40	50	60	70	80	90	100	110	120	130	140
R-502	1.83	1.75	1.67	1.59	1.50	1.42	1.34	1.26	1.17	1.09	1.00	0.91	0.82	0.73	0.64

NOTE: These factors include corrections for liquid refrigerant density and net refrigeration effect, and are based on an average evaporator temperature of 0°F with a maximum 7°F Change in Superheat. However, they may be used for any evaporator temperature from -40°F to +40°F since the variation in the actual factors across this range is insignificant.

R-1234yf balance ported valves (tons) NXT-R / B / H Series

Valve type	Nom. rating	Evaporator temperature																	
		50°F						40°F						20°F					
		Pressure drop across valve (psi)						Pressure drop across valve (psi)						Pressure drop across valve (psi)					
		60	80	100	125	150	175	60	80	100	125	150	175	60	80	100	125	150	175
NXT-R	1/10	0.05	0.05	0.06	0.07	0.07	0.08	0.04	0.05	0.06	0.06	0.07	0.07	0.03	0.04	0.04	0.05	0.05	0.06
NXT-R	1/5	0.12	0.14	0.15	0.17	0.19	0.20	0.11	0.13	0.15	0.16	0.18	0.19	0.09	0.10	0.11	0.13	0.14	0.15
NXT-R	1/4	0.20	0.23	0.25	0.28	0.31	0.33	0.19	0.22	0.24	0.27	0.30	0.32	0.15	0.17	0.19	0.21	0.23	0.25
NXT-R	1/2	0.47	0.54	0.60	0.68	0.74	0.80	0.45	0.52	0.59	0.66	0.72	0.78	0.35	0.40	0.45	0.50	0.55	0.60
NXT-R	3/4	0.62	0.72	0.81	0.90	0.99	1.07	0.61	0.70	0.78	0.87	0.96	1.03	0.47	0.54	0.60	0.67	0.74	0.80
NXT-R	1	0.93	1.07	1.20	1.34	1.47	1.59	0.90	1.04	1.17	1.30	1.43	1.54	0.69	0.80	0.90	1.00	1.10	1.19
NXT-R	1 1/2	1.34	1.55	1.73	1.94	2.12	2.29	1.30	1.50	1.68	1.88	2.06	2.22	1.00	1.16	1.29	1.44	1.58	1.71
BA/BN	1/4	0.15	0.17	0.19	0.22	0.24	0.26	0.15	0.17	0.19	0.21	0.23	0.25	0.11	0.13	0.14	0.16	0.18	0.19
BA/BN	1/2	0.29	0.33	0.37	0.41	0.45	0.49	0.28	0.32	0.36	0.40	0.44	0.47	0.21	0.25	0.27	0.31	0.34	0.36
BA/BN	3/4	0.44	0.51	0.57	0.64	0.70	0.76	0.43	0.50	0.56	0.62	0.68	0.74	0.33	0.38	0.43	0.48	0.52	0.57
BA/BN	1	0.59	0.69	0.77	0.86	0.94	1.02	0.58	0.67	0.74	0.83	0.91	0.99	0.44	0.51	0.57	0.64	0.70	0.76
BA/BN	1-1/4	0.75	0.87	0.97	1.08	1.19	1.28	0.73	0.84	0.94	1.05	1.15	1.24	0.56	0.65	0.72	0.81	0.89	0.96
BA/BN	1-1/2	0.91	1.05	1.17	1.31	1.44	1.55	0.88	1.02	1.14	1.27	1.40	1.51	0.68	0.78	0.88	0.98	1.07	1.16
BA/BN	2	1.18	1.36	1.52	1.70	1.86	2.01	1.14	1.32	1.47	1.65	1.81	1.95	0.88	1.01	1.13	1.27	1.39	1.50
BA/BN	2-1/2	1.49	1.72	1.93	2.15	2.36	2.55	1.45	1.67	1.87	2.09	2.29	2.47	1.11	1.29	1.44	1.61	1.76	1.90
BA/BN	3-1/4	1.85	2.14	2.39	2.67	2.93	3.16	1.80	2.08	2.32	2.59	2.84	3.07	1.38	1.60	1.78	1.99	2.18	2.36
HF	1/8	0.08	0.10	0.11	0.12	0.13	0.14	0.08	0.09	0.11	0.12	0.13	0.14	0.06	0.07	0.08	0.09	0.10	0.11
HF	1/4	0.16	0.18	0.21	0.23	0.25	0.27	0.15	0.18	0.20	0.22	0.24	0.26	0.12	0.14	0.15	0.17	0.19	0.20
HF	1/2	0.29	0.33	0.37	0.41	0.45	0.49	0.28	0.32	0.36	0.40	0.44	0.47	0.21	0.25	0.27	0.31	0.34	0.36
HF	3/4	0.44	0.50	0.56	0.63	0.69	0.74	0.42	0.49	0.55	0.61	0.67	0.72	0.32	0.37	0.42	0.47	0.51	0.55
HF	1	0.59	0.68	0.76	0.85	0.93	1.01	0.57	0.66	0.74	0.82	0.90	0.98	0.44	0.51	0.57	0.63	0.69	0.75
HF	1-1/4	0.75	0.87	0.97	1.09	1.19	1.29	0.73	0.84	0.94	1.06	1.16	1.25	0.56	0.65	0.73	0.81	0.89	0.96
HF	1-3/4	0.99	1.15	1.28	1.43	1.57	1.70	0.96	1.11	1.24	1.39	1.52	1.65	0.74	0.86	0.96	1.07	1.17	1.27
HF	3	1.77	2.04	2.28	2.55	2.80	3.02	1.72	1.98	2.22	2.48	2.71	2.93	1.32	1.52	1.70	1.90	2.09	2.25

NOTE: Standard capacity is rated at 100°F liquid inlet and 40°F evaporator temperature; with 100 PSI pressure drop across the TXV.

R-1234yf balance ported valves (tons) NXT-R / B / H Series (cont'd)

Valve type	Nom. rating	Evaporator temperature																	
		0°F						-20°F						-40°F					
		Pressure drop across valve (psi)						Pressure drop across valve (psi)						Pressure drop across valve (psi)					
		60	80	100	125	150	175	80	100	125	150	175	200	80	100	125	150	175	200
NXT-R	1/10	0.02	0.03	0.03	0.03	0.04	0.04	0.01	0.01	0.01	0.01	0.01	0.01	0.00	0.00	0.01	0.01	0.01	0.01
NXT-R	1/5	0.06	0.07	0.08	0.09	0.09	0.10	0.02	0.02	0.02	0.02	0.03	0.03	0.01	0.01	0.01	0.01	0.02	0.02
NXT-R	1/4	0.10	0.11	0.13	0.14	0.16	0.17	0.04	0.05	0.06	0.06	0.07	0.07	0.03	0.03	0.03	0.04	0.04	0.04
NXT-R	1/2	0.24	0.27	0.31	0.34	0.38	0.41	0.07	0.08	0.09	0.10	0.11	0.12	0.05	0.05	0.06	0.06	0.07	0.07
NXT-R	3/4	0.32	0.37	0.41	0.46	0.50	0.54	0.10	0.11	0.12	0.14	0.15	0.16	0.06	0.07	0.08	0.08	0.09	0.10
NXT-R	1	0.47	0.54	0.61	0.68	0.75	0.81	0.18	0.20	0.22	0.24	0.26	0.28	0.11	0.12	0.14	0.15	0.16	0.17
NXT-R	1 1/2	0.68	0.79	0.88	0.98	1.08	1.16	0.24	0.27	0.30	0.33	0.35	0.38	0.15	0.16	0.18	0.20	0.22	0.23
BA/BN	1/4	0.08	0.09	0.10	0.11	0.12	0.13	0.06	0.06	0.07	0.08	0.08	0.09	0.04	0.04	0.04	0.05	0.05	0.06
BA/BN	1/2	0.14	0.17	0.19	0.21	0.23	0.25	0.11	0.12	0.14	0.15	0.16	0.17	0.07	0.08	0.08	0.09	0.10	0.11
BA/BN	3/4	0.23	0.26	0.29	0.32	0.36	0.38	0.17	0.19	0.21	0.23	0.25	0.27	0.10	0.12	0.13	0.14	0.15	0.17
BA/BN	1	0.30	0.35	0.39	0.43	0.48	0.51	0.23	0.25	0.28	0.31	0.33	0.36	0.14	0.16	0.17	0.19	0.21	0.22
BA/BN	1-1/4	0.38	0.44	0.49	0.55	0.60	0.65	0.29	0.32	0.36	0.39	0.42	0.45	0.18	0.20	0.22	0.24	0.26	0.28
BA/BN	1-1/2	0.46	0.53	0.60	0.67	0.73	0.79	0.35	0.39	0.43	0.47	0.51	0.55	0.21	0.24	0.27	0.29	0.32	0.34
BA/BN	2	0.60	0.69	0.77	0.86	0.94	1.02	0.45	0.50	0.56	0.61	0.66	0.71	0.28	0.31	0.35	0.38	0.41	0.44
BA/BN	2-1/2	0.76	0.87	0.98	1.09	1.20	1.29	0.57	0.63	0.71	0.78	0.84	0.90	0.35	0.39	0.44	0.48	0.52	0.56
BA/BN	3-1/4	0.94	1.08	1.21	1.35	1.48	1.60	0.70	0.79	0.88	0.97	1.04	1.11	0.44	0.49	0.54	0.60	0.64	0.69
HF	1/8	0.04	0.05	0.05	0.06	0.07	0.07	0.03	0.04	0.04	0.04	0.05	0.05	0.02	0.02	0.02	0.03	0.03	0.03
HF	1/4	0.08	0.09	0.10	0.12	0.13	0.14	0.06	0.07	0.08	0.08	0.09	0.10	0.04	0.04	0.05	0.05	0.06	0.06
HF	1/2	0.14	0.17	0.19	0.21	0.23	0.25	0.11	0.12	0.14	0.15	0.16	0.17	0.07	0.08	0.08	0.09	0.10	0.11
HF	3/4	0.22	0.25	0.28	0.32	0.35	0.38	0.17	0.19	0.21	0.23	0.25	0.26	0.10	0.11	0.13	0.14	0.15	0.16
HF	1	0.30	0.34	0.38	0.43	0.47	0.51	0.22	0.25	0.28	0.31	0.33	0.35	0.14	0.15	0.17	0.19	0.20	0.22
HF	1-1/4	0.38	0.44	0.49	0.55	0.60	0.65	0.29	0.32	0.36	0.39	0.42	0.45	0.18	0.20	0.22	0.24	0.26	0.28
HF	1-3/4	0.50	0.58	0.65	0.73	0.80	0.86	0.38	0.42	0.47	0.52	0.56	0.60	0.23	0.26	0.29	0.32	0.35	0.37
HF	3	0.90	1.03	1.16	1.29	1.42	1.53	0.67	0.75	0.84	0.92	1.00	1.06	0.42	0.47	0.52	0.57	0.62	0.66

Refrigerant liquid temperature correction factors

	Refrigerant liquid temperature °F															
	0	10	20	30	40	50	60	70	80	90	100	110	120	130	140	
R-1234yf	1.89	1.80	1.72	1.63	1.54	1.45	1.36	1.27	1.18	1.09	1.00	0.91	0.82	0.72	0.63	

NOTE: These factors include corrections for liquid refrigerant density and net refrigeration effect, and are based on an average evaporator temperature of 0°F with a maximum 7°F Change in Superheat. However, they may be used for any evaporator temperature from -40°F to +40°F since the variation in the actual factors across this range is insignificant.

R-1234ze balance ported valves (tons) NXT-R/ B / H Series

Valve type	Nom. rating	Evaporator temperature																	
		50°F						40°F						20°F					
		Pressure drop across valve (psi)						Pressure drop across valve (psi)						Pressure drop across valve (psi)					
		60	80	100	125	150	175	60	80	100	125	150	175	60	80	100	125	150	175
NXT-R	1/10	0.04	0.04	0.05	0.05	0.06	0.06	0.04	0.04	0.05	0.05	0.06	0.06	0.02	0.02	0.03	0.03	0.03	0.03
NXT-R	1/5	0.09	0.11	0.12	0.13	0.14	0.16	0.09	0.11	0.12	0.13	0.15	0.16	0.05	0.06	0.07	0.08	0.08	0.09
NXT-R	1/4	0.15	0.18	0.20	0.22	0.24	0.26	0.16	0.18	0.20	0.22	0.25	0.27	0.09	0.10	0.11	0.13	0.14	0.15
NXT-R	1/2	0.37	0.42	0.47	0.53	0.58	0.62	0.37	0.43	0.48	0.54	0.59	0.64	0.21	0.25	0.27	0.31	0.34	0.36
NXT-R	3/4	0.49	0.56	0.63	0.70	0.77	0.83	0.50	0.57	0.64	0.72	0.79	0.85	0.28	0.33	0.37	0.41	0.45	0.48
NXT-R	1	0.73	0.84	0.94	1.05	1.15	1.24	0.74	0.86	0.96	1.07	1.17	1.27	0.42	0.49	0.54	0.61	0.67	0.72
NXT-R	1 1/2	1.05	1.21	1.35	1.51	1.66	1.79	1.07	1.23	1.38	1.54	1.69	1.82	0.61	0.70	0.79	0.88	0.96	1.04
NXT-R	2	0.73	0.84	0.94	1.05	1.15	1.24	0.74	0.86	0.96	1.07	1.17	1.27	0.42	0.49	0.54	0.61	0.67	0.72
NXT-R	3 1/4	1.05	1.21	1.35	1.51	1.66	1.79	1.07	1.23	1.38	1.54	1.69	1.82	0.61	0.70	0.79	0.88	0.96	1.04
BA/BN	1/4	0.15	0.17	0.19	0.22	0.24	0.26	0.15	0.17	0.19	0.21	0.23	0.25	0.11	0.13	0.14	0.16	0.18	0.19
BA/BN	1/2	0.29	0.33	0.37	0.41	0.45	0.49	0.28	0.32	0.36	0.40	0.44	0.47	0.21	0.25	0.27	0.31	0.34	0.36
BA/BN	3/4	0.44	0.51	0.57	0.64	0.70	0.76	0.43	0.50	0.56	0.62	0.68	0.74	0.33	0.38	0.43	0.48	0.52	0.57
BA/BN	1	0.59	0.69	0.77	0.86	0.94	1.02	0.58	0.67	0.74	0.83	0.91	0.99	0.44	0.51	0.57	0.64	0.70	0.76
BA/BN	1-1/4	0.75	0.87	0.97	1.08	1.19	1.28	0.73	0.84	0.94	1.05	1.15	1.24	0.56	0.65	0.72	0.81	0.89	0.96
BA/BN	1-1/2	0.91	1.05	1.17	1.31	1.44	1.55	0.88	1.02	1.14	1.27	1.40	1.51	0.68	0.78	0.88	0.98	1.07	1.16
BA/BN	2	1.18	1.36	1.52	1.70	1.86	2.01	1.14	1.32	1.47	1.65	1.81	1.95	0.88	1.01	1.13	1.27	1.39	1.50
BA/BN	2-1/2	1.49	1.72	1.93	2.15	2.36	2.55	1.45	1.67	1.87	2.09	2.29	2.47	1.11	1.29	1.44	1.61	1.76	1.90
BA/BN	3-1/4	1.85	2.14	2.39	2.67	2.93	3.16	1.80	2.08	2.32	2.59	2.84	3.07	1.38	1.60	1.78	1.99	2.18	2.36
HF	1/8	0.08	0.10	0.11	0.12	0.13	0.14	0.08	0.09	0.11	0.12	0.13	0.14	0.06	0.07	0.08	0.09	0.10	0.11
HF	1/4	0.16	0.18	0.21	0.23	0.25	0.27	0.15	0.18	0.20	0.22	0.24	0.26	0.12	0.14	0.15	0.17	0.19	0.20
HF	1/2	0.29	0.33	0.37	0.41	0.45	0.49	0.28	0.32	0.36	0.40	0.44	0.47	0.21	0.25	0.27	0.31	0.34	0.36
HF	3/4	0.44	0.50	0.56	0.63	0.69	0.74	0.42	0.49	0.55	0.61	0.67	0.72	0.32	0.37	0.42	0.47	0.51	0.55
HF	1	0.59	0.68	0.76	0.85	0.93	1.01	0.57	0.66	0.74	0.82	0.90	0.98	0.44	0.51	0.57	0.63	0.69	0.75
HF	1-1/4	0.75	0.87	0.97	1.09	1.19	1.29	0.73	0.84	0.94	1.06	1.16	1.25	0.56	0.65	0.73	0.81	0.89	0.96
HF	1-3/4	0.99	1.15	1.28	1.43	1.57	1.70	0.96	1.11	1.24	1.39	1.52	1.65	0.74	0.86	0.96	1.07	1.17	1.27
HF	3	1.77	2.04	2.28	2.55	2.80	3.02	1.72	1.98	2.22	2.48	2.71	2.93	1.32	1.52	1.70	1.90	2.09	2.25

NOTE: Standard capacity is rated at 100°F liquid inlet and 40°F evaporator temperature; with 100 PSI pressure drop across the TXV.

R-1234ze balance ported valves (tons) NXT-R/ B/ H Series (cont'd)

Valve type	Nom. rating	Evaporator temperature																	
		0°F						-20°F						-40°F					
		Pressure drop across valve (psi)						Pressure drop across valve (psi)						Pressure drop across valve (psi)					
		60	80	100	125	150	175	80	100	125	150	175	200	80	100	125	150	175	200
NXT-R	1/10	0.01	0.02	0.02	0.02	0.02	0.02	0.01	0.01	0.01	0.01	0.01	0.02	0.01	0.01	0.01	0.01	0.01	0.01
NXT-R	1/5	0.04	0.04	0.05	0.05	0.06	0.06	0.03	0.03	0.03	0.04	0.04	0.04	0.02	0.02	0.02	0.02	0.02	0.02
NXT-R	1/4	0.06	0.07	0.08	0.08	0.09	0.10	0.04	0.05	0.05	0.06	0.06	0.07	0.03	0.03	0.03	0.04	0.04	0.04
NXT-R	1/2	0.14	0.16	0.18	0.20	0.22	0.24	0.10	0.11	0.13	0.14	0.15	0.16	0.06	0.07	0.08	0.08	0.09	0.10
NXT-R	3/4	0.19	0.22	0.24	0.27	0.30	0.32	0.14	0.15	0.17	0.19	0.20	0.22	0.08	0.09	0.10	0.11	0.12	0.13
NXT-R	1	0.28	0.32	0.36	0.40	0.44	0.48	0.20	0.23	0.25	0.28	0.30	0.32	0.12	0.14	0.15	0.17	0.18	0.19
NXT-R	1 1/2	0.40	0.47	0.52	0.58	0.64	0.69	0.29	0.33	0.37	0.40	0.43	0.46	0.18	0.20	0.22	0.24	0.26	0.28
NXT-R	2	0.28	0.32	0.36	0.40	0.44	0.48	0.20	0.23	0.25	0.28	0.30	0.32	0.12	0.14	0.15	0.17	0.18	0.19
NXT-R	3 1/4	0.40	0.47	0.52	0.58	0.64	0.69	0.29	0.33	0.37	0.40	0.43	0.46	0.18	0.20	0.22	0.24	0.26	0.28
BA/BN	1/4	0.08	0.09	0.10	0.11	0.12	0.13	0.06	0.06	0.07	0.08	0.08	0.09	0.04	0.04	0.04	0.05	0.05	0.06
BA/BN	1/2	0.14	0.17	0.19	0.21	0.23	0.25	0.11	0.12	0.14	0.15	0.16	0.17	0.07	0.08	0.08	0.09	0.10	0.11
BA/BN	3/4	0.23	0.26	0.29	0.32	0.36	0.38	0.17	0.19	0.21	0.23	0.25	0.27	0.10	0.12	0.13	0.14	0.15	0.17
BA/BN	1	0.30	0.35	0.39	0.43	0.48	0.51	0.23	0.25	0.28	0.31	0.33	0.36	0.14	0.16	0.17	0.19	0.21	0.22
BA/BN	1-1/4	0.38	0.44	0.49	0.55	0.60	0.65	0.29	0.32	0.36	0.39	0.42	0.45	0.18	0.20	0.22	0.24	0.26	0.28
BA/BN	1-1/2	0.46	0.53	0.60	0.67	0.73	0.79	0.35	0.39	0.43	0.47	0.51	0.55	0.21	0.24	0.27	0.29	0.32	0.34
BA/BN	2	0.60	0.69	0.77	0.86	0.94	1.02	0.45	0.50	0.56	0.61	0.66	0.71	0.28	0.31	0.35	0.38	0.41	0.44
BA/BN	2-1/2	0.76	0.87	0.98	1.09	1.20	1.29	0.57	0.63	0.71	0.78	0.84	0.90	0.35	0.39	0.44	0.48	0.52	0.56
BA/BN	3-1/4	0.94	1.08	1.21	1.35	1.48	1.60	0.70	0.79	0.88	0.97	1.04	1.11	0.44	0.49	0.54	0.60	0.64	0.69
HF	1/8	0.04	0.05	0.05	0.06	0.07	0.07	0.03	0.04	0.04	0.04	0.05	0.05	0.02	0.02	0.02	0.03	0.03	0.03
HF	1/4	0.08	0.09	0.10	0.12	0.13	0.14	0.06	0.07	0.08	0.08	0.09	0.10	0.04	0.04	0.05	0.05	0.06	0.06
HF	1/2	0.14	0.17	0.19	0.21	0.23	0.25	0.11	0.12	0.14	0.15	0.16	0.17	0.07	0.08	0.08	0.09	0.10	0.11
HF	3/4	0.22	0.25	0.28	0.32	0.35	0.38	0.17	0.19	0.21	0.23	0.25	0.26	0.10	0.11	0.13	0.14	0.15	0.16
HF	1	0.30	0.34	0.38	0.43	0.47	0.51	0.22	0.25	0.28	0.31	0.33	0.35	0.14	0.15	0.17	0.19	0.20	0.22
HF	1-1/4	0.38	0.44	0.49	0.55	0.60	0.65	0.29	0.32	0.36	0.39	0.42	0.45	0.18	0.20	0.22	0.24	0.26	0.28
HF	1-3/4	0.50	0.58	0.65	0.73	0.80	0.86	0.38	0.42	0.47	0.52	0.56	0.60	0.23	0.26	0.29	0.32	0.35	0.37
HF	3	0.90	1.03	1.16	1.29	1.42	1.53	0.67	0.75	0.84	0.92	1.00	1.06	0.42	0.47	0.52	0.57	0.62	0.66

Refrigerant liquid temperature correction factors

	Refrigerant liquid temperature °F															
	0	10	20	30	40	50	60	70	80	90	100	110	120	130	140	
R-1234ze	1.74	1.67	1.60	1.52	1.45	1.37	1.30	1.22	1.15	1.08	1.00	0.92	0.85	0.77	0.70	

NOTE: These factors include corrections for liquid refrigerant density and net refrigeration effect, and are based on an average evaporator temperature of 0°F with a maximum 7°F Change in Superheat. However, they may be used for any evaporator temperature from -40°F to +40°F since the variation in the actual factors across this range is insignificant.



EX5-U21 800618

# EX4-EX8 Series Electrical Control Valves

The EX4-EX8 Series are bi-polar stepper motor driven valves optimized for the control of liquid or gaseous mass flow in refrigeration systems. Multifunction capability as expansion valve, hot gas bypass, suction gas throttling, head pressure, liquid line actuator and other applications systems.

## Features

- Fully hermetic stainless steel design
- Fast full stroke time
- Ceramic slide and port for accurate flow and minimal wear
- High resolution and excellent repeatability
- Bi-directional versions for heat pump applications
- Positive shut-off function to eliminate the use of an additional solenoid valve
- Linear flow capacity
- Wide capacity range (10 - 100%)
- Continuous modulation of mass flow, no stress (liquid hammering) in the refrigeration circuit
- Direct coupling of motor and valve for high reliability (no gear mechanism)
- Applicable to all common A1, A2L, A3 refrigerants, including subcritical CO<sub>2</sub>, R-290
- EX4 to EX7 uniflow models comply with the A2L Safety Shut-off Valve standards of UL 60335-2-40 and 60335-2-89 when equipped with battery back-up

## Specifications

CE marking.....	EX4/EX5 not required, EX6-EX8 required Cat I, Module A
Maximum operating pressure differential.....	EX4-EX6: 580 psid (40 bar)
.....	EX7: 507 psid (35 bar)
.....	EX8: 435 psid (30 bar)
Maximum working pressure.....	EX4-EX7: 870 psig (60 bar)
.....	EX8: 650 psig (45 bar)
Ambient Temperature.....	-40°F/C to 131°F (55°C)
Storage Temperature.....	-40°F/C to 158°F (70°C)
Medium Inlet Temperature.....	Uni-flow: -58°F/50°C to 212°F (100°C)
.....	Bi-flow: -58°F/50°C to 176°F (80°C)
Operating humidity.....	5 to 95% R.H.
External leakage.....	0.1 oz./yr. (R-22)
Connectors.....	4 pin terminal via plug
Driver supply voltage.....	24 VDC Nominal, Range: 18-36 VDC
Full travel time.....	EX4-EX6: 1.5 seconds
.....	EX7: 3.2 seconds
.....	EX8: 5.2 seconds
Total number of full steps.....	EX4-EX6: 750
.....	EX7: 1600
.....	EX8: 2600
Phase current (operating).....	EX4-EX6: 500 mA max
.....	EX7 750 mA
.....	EX8 800 mA
Holding current.....	EX4-EX6: 100 mA
.....	EX7: 250 mA
.....	EX8: 500 mA
Nominal input power per phase.....	EX4-EX6: 3.5W
.....	EX7-EX8: 5W
Phase inductance.....	EX4-EX6: 100 mA
.....	EX7: 250 mA
.....	EX8: 500 mA
UL file number.....	MP604
Canadian CRN.....	OC15839.5C

EX4-EX8 series stepper motor driven valves

Description	Inlet connection (in)	Outlet connection (in)	Model number	Item number
EX4 Electrical Control Valve	3/8	5/8	EX4-I21 800615	097719
EX5 Electrical Control Valve	5/8	7/8	EX5-U21 800618	097720
EX6 Electrical Control Valve	7/8	1-1/8	EX6-I21 800620	097721
EX7 Electrical Control Valve	1-1/8	1-3/8	EX7-I21 800624	097722
EX8 Electrical Control Valve	1-5/8	1-5/8	EX8-I21 800631	097723
EX4 Bi-Flow Electrical Control Valve	5/8	5/8	EX4-U31 800617	097756
EX5 Bi-Flow Electrical Control Valve	7/8	7/8	EX5-U31 800619	097729
EX6 Bi-Flow Electrical Control Valve	1-1/8	1-1/8	EX6-I31 800622	097757
EX7 Bi-Flow Electrical Control Valve	1-3/8	1-3/8	EX7-U31 800626	097758

EX4-EX8 series parts & accessories

Description	Model number	Item number
Superheat and/or Temperature Controller for 1 Valve	EXD-SH1 807855	097175
Superheat and/or Temperature Controller for 2 Valves	EXD-SH2 807856	097176
Superheat and/or Temperature Controller kit for 1 Valve (Kit includes 1 each EXD-SH1, EXV-M60, PT5B-18M, PT4-M60 FLR, TP1-NP6, EXD-M03, 90-T40F3). Valve not included.	EXD-SH1K	EXD-SH1K
Superheat and/or Temperature Controller kit for 2 Valves (Kit includes 1 each EXD-SH2, EXD-M03, 90-T50F3 and two of each EXV-M60, PT5B-18M, PT4-M60 FLR, TP1-NP6, ). Valve not included.	EXD-SH2K	EXD-SH2K
Universal driver	EXD-U02 808053	808053
Cable for supply voltage, 3 meters	EXD-M03 807865	097177
Electronic Expansion Valve Cable and Connector, 1.5 meters	EXV-M15	804870
Electronic Expansion Valve Cable and Connector, 3 meters	EXV-M30	804871
Electronic Expansion Valve Cable and Connector, 6 meters	EXV-M60	804872
Pressure Transmitter able to operate in a vacuum	PT5B-10M	808360
Pressure Transmitter including R-410A	PT5B-18M	808361
Pressure Transmitter including R-744, 435 psig	PT5B-30M	808362
Pressure Transmitter including R-744, 725 psig	PT5B-50M	808365
Pressure Transmitter including R-744, 2,175 psig	PT5-150D	802379
Plug & Cable Assy for Pressure Transmitter, 1 meter	PT4-M10 FLR	804886
Plug & Cable Assy for Pressure Transmitter, 3 meters	PT4-M15 FLR	804887
Plug & Cable Assy for Pressure Transmitter, 6 meters	PT4-M60 FLR	804883
Plug & Cable Assy for Pressure Transmitter, 6 meters (cable for PT5-150D)	PT4-M60	804882
Temperature Sensor, 6 meters cable	TP1-NP6 804490	804490
Transformer for 1 circuit	90-T40F3	90-T40F3
Transformer 2 circuits	90-T50F3	90-T50F3
Backup battery with two outputs for two controllers	ECP-024	804558
Terminal Kit for ECP-024	K09-P00	804560

EX4-EX8 series nominal capacities in tons 10% - 100% (based on capacities table conditions below)

Valve type	R-407C	R-22	R-134a	R-404A	R-410A	R-23	R-124	R-744
EX4	.6 – 5	.6 – 4.7	.3 – 3.6	.3 – 3.3	.6 – 5.5	.6 – 5.1	.3 – 2.6	.9 – 9.5
EX5	1.4 – 15.1	1.4 – 14.2	1.1 – 11.1	1.1 – 10	1.7 – 16.5	1.4 – 15.4	.9 – 8	2.8 – 29
EX6	4.3 – 35.8	4.3 – 34.1	2.8 – 26.4	2.8 – 23.9	4.3 – 39.8	3.7 – 37	2 – 19.1	6.8 – 69.4
EX7	10 – 98.7	10 – 93.8	7.1 – 72.5	7.1 – 65.4	11.4 – 109.5	—	—	19.9 – 190.5
EX8	28.4 – 263	25.6 – 250.2	19.9 – 193.4	17.1 – 174.3	28.4 – 292	—	—	51.2 – 508.7

Capacities table conditions

Refrigerant	Evaporating temperature	Condensing temperature	Subcooling
R-22, R-134A, R-404A, R-410A	+40 °F	+100°F	2°F
R-407C	+40°F dew point	+100°F bubble	2°F
R-124	+68°F	+176°F	2°F
R-23	-76°F	-13°F	2°F
R-744	-40°F	14°F	2°F



Instruction Sheet with detailed product drawings



Capacity Tables (Tons)



EXD-SH2

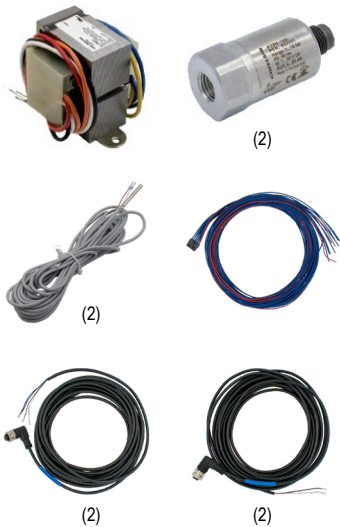
# EXD-SH1 & EXD-SH2 Series Temperature & Superheat Controllers & Kits

Stand-alone universal superheat and or temperature controllers for air conditioning units or refrigeration systems. Recommended for use with bi-polar EX Series or CV Series expansion valves.

## Features

- EXD-SH1 controls one valve and EXD-SH2 can control two valves in two independent circuits
- Functions as a superheat control, temperature control, low pressure switch and freeze protection
- Self-adapting superheat control function in conjunction with Copeland EX4-8 series valves
- Easy system monitoring with Modbus communication
- Integrated keyboard with two line display
- Self adaptive algorithm eliminates need for setting PID control for individual systems
- Flash key to allow quick upload and download of parameters from one configured controller to another
- Multiple function alarms including low/high superheat alarm
- Electrical connection via plug-in type screw terminals
- Controllers sold separately or in pre-assembled kits (EXD-SH1K and EXD-SH2K)

### Parts included in kits



(2) Signifies x2 for EXD-SH2K

## Specifications

Supply voltage ..... 24VAC/DC +or-10%, 50/60Hz  
 Power consumption..... EXD-SH1 Max. 25 VA / EXD-SH2 Max. 50 VA  
 Terminals 1 to 12 ..... Suitable for 12 poles molex plug  
 Terminals 13 to 36 ..... Suitable for removable screw version: wire size 0.005...0.006 in  
 Temperatures..... Storage: -13°F (-25°C) to 140°F (60°C)  
 ..... Operating: 32°F (0°C) to 131°F (55°C)  
 Humidity..... 20 to 85% R.H. non condensing  
 Mounting..... DIN RAIL mounting  
 Weight..... 0.71 lbs.  
 Housing..... Self-extinguishing ABS  
 Protection class..... IP 00  
 Agency ..... CE, EAC  
 Compliance ..... RoHS

### Input, output EXD-SH1, EXD-SH2

Description	Specification
Analog input(s): NTC Temperature sensor Analog input: PT1000 Temperature sensor	ECN-N...-49°F (-45°C)...122°F (50°C) sensing range ECN-Z60 sensing range
Analog input(s): 4-20 mA pressure transmitters Analog input(s): 0.5-4.5 V pressure transmitters	PT5B Third party ratio metric pressure transmitters (total error: ≤ 1%)
Digital input(s)	Dry contact, potential free
Digital output(s): Alarm relay(s) Contact closed: During alarm condition Contact open: During normal operation & supply power OFF	Resistive Load 24 VAC/DC, max. 1 A Inductive Load 24 VAC, max. 0.5 A
Communication	RS485 RTU Modbus, two wires
Stepper motor output	Bi-Polar Valves: EX4-8
Refrigerants	R-22; R-134a; R-507; R-404A; R-407C; R-410A; R-124; R-744; R-407A; R-407F; R-23; R-32*; R-1234ze; R-448A; R-449A; R-450A; R-513A

\* R-32 is for systems/regions which it does not consider R-32 as potential explosive refrigerant (flammable or low flammable) and PED/CE marking is not required.

*EXD-SH1 & EXD-SH2 controllers & kits*

Description	Model number	Item number
EXD-SH1 is a Superheat and/or Temperature Controller for a single EX4-8 or CV4-6 valves	EXD-SH1 807855	097175
EXD-SH2 is a Superheat and/or Temperature Controller with Second Circuit Superheat Control for Two EX4-8 or CV4-6 valves	EXD-SH2 807856	097176
Superheat and/or Temperature Controller kit for 1 Valve (Kit includes 1 each EXD-SH1, EXV-M60, PT5B-18M, PT4-M60 FLR, TP1-NP6, EXD-M03, 90-T40F3). Valve not included.	EXD-SH1K	EXD-SH1K
Superheat and/or Temperature Controller kit for 2 Valves (Kit includes 1 each EXD-SH2, EXD-M03, 90-T50F3 and two of each EXV-M60, PT5B-18M, PT4-M60 FLR, TP1-NP6, ). Valve not included.	EXD-SH2K	EXD-SH2K

*EXD-SH1 & EXD-SH2 parts and accessories*

Description	Model number	Item number
12 Pin Molex Plug with 3 Meter Cable for EXD-SH1 and EXD-SH2 for Supply Voltage, Temperature Sensor 1 and 2, PT5 Circuit 1 and 2, Vdc and Ground	EXD-M03 807865	097177
Electronic Expansion Valve Cable and Connector	EXV-M60	804872
Pressure Transmitter for applications needed to operate in a vacuum*	PT5B-10M	808360
Pressure Transmitter for refrigerants including R-410A	PT5B-18M	808361
Pressure Transmitter for refrigerants including R-744*, 435 psig	PT5B-30M	808362
Pressure Transmitter for refrigerants including R-744*, 725 psig	PT5B-50M	808365
6 Meter Long Plug and Cable Assembly for PT5 Pressure Transmitter	PT4-M60 FLR	804883
Electronic Expansion Valve Temperature Sensor with a 6 Meter Cable	TP1-NP6 804490	804490
Transformer 12/208/240 Primary, 24V Secondary 40VA, for 1 circuit	90-T40F3	90-T40F3
Transformer 12/208/240 Primary, 24V Secondary 50VA, for 2 circuits	90-T50F3	90-T50F3
Backup battery with two outputs for two controllers	ECP-024	804558
Terminal Kit for ECP-024	K09-P00	804560

\* Not included in kit  
 Refer to PT5B catalog for other pressure transmitters



EXD-U02 808053

# EXD-U02 Universal Driver Module

The EXD-U02 is a universal driver that enables the operation of Copeland EX4 - EX8 and CV4 - CV6 stepper motor driven valves used in applications such as solenoid valves, electronic expansion valves, hot gas bypass or evaporator pressure regulator as capacity control, crankcase pressure regulator, heat reclaim regulator, and liquid level control.

## Features

- Plug and play, no parameter settings required
- Digital input can be used to force valve closing
- Dip-switches for selection of electronic control valve type, analog input and start mode
- Step recovery function
- Direct replacement for EXD-U01

## Specifications

Supply voltage .....24 VAC ±10%, 50-60 Hz  
**Note:** .....24 VDC supply voltage can be used but it results to lower MOPD  
 .....and it needs to be verified by system manufacturer  
 Supply current..... To be protected by a 1.0A external fuse  
 Power consumption..... 10VA in conjunction with electronic valve  
 Temperature..... Storage: -4°F to 149°F (-20° C to 65°C)  
 ..... Operating: 32°F to +140°F (0°C to 60°C)  
 Humidity..... < 90% R.H. non condensing  
 Approvals..... EMC EN 61326-1, EN50081, EN50082  
 Marking ..... CE, UKCA, EAC  
 Protection class.....IP20  
 Input analogue signal..... 4-20 mA or 0-10V  
 .....Burden 364 Ω  
 ..... Impedence 24KΩ  
 Digital input .....24V AC ±10%, 50-60Hz, 24V DC ±10%  
 Connection to EX4-8 and CV4-6..... Via 4 wires cable, AWG 20/22  
 Connector..... Screw terminals for wire size 0.5-2.5 mm2  
 Mounting..... DIN rail mounted  
 Housing.....Aluminum

### EXD-U02 universal driver module

Description	Model number	Item number
Universal Driver Module with Terminal Kit for EX4-EX8 and CV4-CV6	EXD-U02 808053	808053
Terminal Kit for EXD-U02	K09-U00	804559
Backup battery with two outputs for two controllers	ECP-024	804558
Terminal Kit for ECP-024	K09-P00	804560



Installation  
Instructions



Application  
& Technical  
Information

# PT5B Series Pressure Transmitters

PT5B Pressure Transmitters convert pressure into a linear electrical 4...20 mA output signal that is optimized for refrigeration and air conditioning applications.



PT5B-xxT



PT5B-xxM

## Features

- Fully hermetic
- Hybrid film technology where the pressure measuring cell is fully welded with the pressure transducer without seals
- With output signal 4...20 mA and 2-wire connection for the precise operation of superheat, compressor or fan control systems
- Calibrated for specific temperature and pressure ranges
- Easy install PT4-FLR cable assemblies available in various lengths
- Vibration, shock and pulsation resistant
- Protection class IP67 with PT4-FLR cable assembly
- Replacement for PT5N series
- Compatible with A1 refrigerants (HFC and certain HFO-blends), A2L refrigerants and A3 (Propane)

## Specifications

Maximum allowable pressure .....	986 psi (68 bar)
Supply voltage .....	Nominal 24 VDC
.....	Range (polarity protected) 8 - 32 VDC
Operating current .....	4 to 20 mA output, Max. ≤ 10 mA
Load resistance .....	RL ≤ Ub-8.0V 0.02A
Mounting position .....	Non-position sensitive
Response time .....	<10 ms
Ambient/storage/transport: temperature .....	-40°F/C to 212°F (100°C)
Medium temperature .....	-22°F (-30°C) to 275°F (135°C)
Sensor life .....	1 million cycles
Vibration at 10-2000 Hz .....	PT5B-...T: 5 G
.....	PT5B-...M: 10 G
Weight (without plug and cable assembly) .....	PT5B-...T: ~ 40 g
.....	PT5B-...M: ~ 48 g
Approvals .....	EMC 2014/30/EU (EN 61326)
.....	II 3G Ex ec IIC G
.....	UL File No. SA46306

Pressure transmitters

Model	Item No	Pressure range (gauge)	Pressure connection
Pressure limiter for high pressure protection PSH EN 12263			
PT5B-10M	808360	-23.62 inHg to 145 psi	7/16" - 20 UNF (with Schrader valve opener)
PT5B-18M	808361	0 to 261 psi	
PT5B-30M	808362	0 to 435 psi	
PT5B-35M	808363	0 to 507.5 psi	
PT5B-40M	808364	0 to 580 psi	
PT5B-50M	808365	0 to 725 psi	
PT5B-10T	808366	-23.62 inHg to 145 psi	Solder 6.35 x 50 mm
PT5B-18T	808367	0 to 261 psi	
PT5B-30T	808368	0 to 435 psi	
PT5B-35T	808369	0 to 507.5 psi	
PT5B-40T	808370	0 to 580 psi	
PT5B-50T	808371	0 to 725 psi	
*PT5B-150D	Coming Soon	0 to 2,175 psi	1/4"-18 NPT (male)
**PT5-150D	802379	0 to 2,175 psi	1/4"-18 NPT (male)

Pressure transmitters parts and accessories

Description	Temperature range	Model	Item number
1 Meter Long Plug and Cable Assembly for Pressure Transmitter Connection to a controller	-40°F to 158°F	PT4-M10 FLR	804886
1.5 Meter Long Plug and Cable Assembly for Pressure Transmitter Connection to a controller		PT4-M15 FLR	804887
6 Meter Long Plug and Cable Assembly for Pressure Transmitter Connection to a controller		PT4-M60 FLR	804883
6 Meter Long Plug and Cable Assembly for Pressure Transmitter Connection to a controller		***PT4-M60	804882

Note: \*PT5B-150D release date coming soon

\*\*PT5-150D will be obsolete when the PT5B-150D is released

\*\*\*PT4-M60 cable for PT5-150D



**PM 1S34VLC-01 1832052**  
**Shown with coil AMF**  
**1-03 1838438**

# PM Series Pulse width Modulating (PWM) Expansion Valves

The PM Series is a normally closed PWM expansion valve for various refrigeration applications, such as display cases and frozen beverage dispensers.

## Features

- Gate-type, direct-acting solenoid valve with six fixed-capacity sizes
- Brass forged body with copper connections
- Compatible with a wide range of system refrigerants
  - All A1 class refrigerants, including R-744
  - A2L class refrigerants R-1234yf, R-1234ze, R-32, R-452B, R-454A, R-454B, R-454C, R-455A
  - A3 class refrigerant R-290
- Coils: AM Series 50/60 Hz (24, 120, and 208-240 VAC) and ASC2 Series 50/60 Hz (24 and 120 VAC)
- Recommended upstream filter-drier: Copeland EK or ALF
- Recommended controllers: Copeland XM679, CC200, or XEV12D

## Specifications

Maximum fluid temperature ..... 221°F (105°C)  
 Maximum working pressure ..... 680 psig (47 bar)  
 Maximum operating pressure differential..... 500 psig (35 bar)  
 UL/CUL file number ..... MP604

### Model number nomenclature - Example: PM 1S34VLC-01

Valve series	Valve size	Connection type	Inlet size	Outlet size	*Coil	Sequential identifier	Customer special	Pack type
PM	1	S	3	4	VLC	-01		
Normally Closed PWM Valves	1/4, 1/2, 1, 3, 5, 6	S = ODF	In 1/8" 3 = 3/8"	In 1/8" 4 = 1/2"	VLC = Valve Less Coil	-01 Thru -99	G = Customer Special (Omit for Standard)	B1 = Bulk Pack (Omit for Individual Pack)

\*Valves in catalog are shipped without solenoid coils (VLC = Valve Less Coil). Valves require an AM Series or ASC2 Series coil assembly. See Recommended Coil ordering information below.

### PM series PWM expansion valves

Valve size	Connection type	Inlet size	Outlet size	Nominal capacity in tons (kw) - rated at 100% duty cycle									Model number	Item number
				R-134a	R-290	R-404a/ R-452a/ R-507	R-407c/ R-448a/ R-449a	R-454c	R-455a	R-513a/ R-450a	R-744 -20°F (-29°C) Evaporator	R-744 +20°F (-7°C) Evaporator		
1/4	ODF	3/8"	1/2"	0.10 (0.37)	0.13 (0.45)	0.09 (0.33)	0.14 (0.48)	0.12 (0.41)	0.14 (0.48)	0.11 (0.39)	0.31 (1.08)	0.22 (0.77)	PM 1/4S34VLC-01	1832044
1/2	ODF	3/8"	1/2"	0.20 (0.70)	0.26 (0.91)	0.18 (0.63)	0.26 (0.92)	0.23 (0.82)	0.27 (0.96)	0.21 (0.75)	0.59 (2.07)	0.42 (1.49)	PM 1/2S34VLC-01	1832036
1	ODF	3/8"	1/2"	0.71 (2.50)	0.91 (3.21)	0.64 (2.24)	0.93 (3.26)	0.83 (2.92)	0.96 (3.39)	0.76 (2.66)	2.10 (7.38)	1.50 (5.29)	PM 1S34VLC-01	1832052
3	ODF	3/8"	1/2"	1.50 (5.28)	1.92 (7.21)	1.34 (4.72)	1.95 (6.87)	1.74 (6.13)	2.02 (7.11)	1.59 (5.60)	4.42 (15.5)	3.17 (11.1)	PM 3S34VLC-01	1832061
5	ODF	3/8"	1/2"	2.23 (7.86)	2.85 (10.71)	2.00 (7.03)	2.91 (10.24)	2.59 (9.10)	3.00 (10.57)	2.37 (8.34)	6.58 (23.1)	4.72 (16.6)	PM 5S34VLC-01	1832079
6	ODF	3/8"	1/2"	2.76 (9.69)	3.51 (13.21)	2.46 (8.67)	3.59 (12.63)	3.19 (11.22)	3.70 (13.03)	2.93 (10.29)	8.12 (28.6)	5.82 (20.5)	PM 6S34VLC-01	1832087

All capacities shown are at 100°F/+38°C condensing and 40°F/+4°C evaporator temperature, except for R744 with 50°F/+10°C (638 psig/44 barg) entering liquid and either -20°F/-29°C (200 psig/13.8 barg) or +20°F/-7°C (407 psig/28.1 barg) evaporator, as indicated. All capacities shown are at 100% duty cycle (zero reserve capacity). Sizing is recommended for 50-80% duty cycle to accommodate load fluctuations. See Extended Capacity Tables for Ratings for a wide range of conditions and refrigerants. The refrigerant entering the valve must be in the liquid phase.

### Recommended coils for PM series valves

Coil series	Voltage	Watts 50/60 hz	Enclosure type	Leads	Model number	Item number
AMF	24 VAC	17/12	Open Frame with Coated Metal Housing for Enhanced Corrosion Resistance	18"	AMF 1-03	1838438
	120 VAC	17/12		18"	AMF 2-02	1838446
	208-240 VAC	17/12		18"	AMF 3-02	1838454

See catalog for additional AM Series and ASC2 Series coils.

# PM Series extended capacity tables

## Expansion valve capacity at 100% duty cycle

### Tons

Valve size	Evaporator temperature											
	50°F						40°F					
	Pressure drop across valve (psi)						Pressure drop across valve (psi)					
	60	80	100	125	150	175	60	80	100	125	150	175
1/4	0.04	0.05	0.05	0.06	0.07	0.07	0.04	0.05	0.05	0.06	0.06	0.07
1/2	0.08	0.10	0.11	0.12	0.13	0.14	0.08	0.09	0.11	0.12	0.13	0.14
1	0.30	0.34	0.38	0.43	0.47	0.51	0.29	0.33	0.37	0.42	0.46	0.49
3	0.62	0.72	0.81	0.90	0.99	1.07	0.61	0.70	0.78	0.87	0.96	1.03
5	0.93	1.07	1.20	1.34	1.47	1.58	0.90	1.04	1.16	1.30	1.42	1.54
6	1.14	1.32	1.48	1.65	1.81	1.95	1.11	1.28	1.43	1.60	1.75	1.90

Note: Standard capacity is rated at 100°F liquid inlet and 40°F evaporator temperature; with 100 psi pressure drop across the valve per AHRI 750.

Valve size	Evaporator temperature											
	20°F						0°F					
	Pressure drop across valve (psi)						Pressure drop across valve (psi)					
	60	80	100	125	150	175	60	80	100	125	150	175
1/4	0.03	0.04	0.04	0.05	0.05	0.05	0.02	0.02	0.03	0.03	0.03	0.04
1/2	0.06	0.07	0.08	0.09	0.10	0.11	0.04	0.05	0.05	0.06	0.07	0.07
1	0.22	0.26	0.29	0.32	0.35	0.38	0.15	0.17	0.19	0.22	0.24	0.26
3	0.47	0.54	0.60	0.67	0.74	0.80	0.32	0.37	0.41	0.46	0.50	0.54
5	0.69	0.80	0.89	1.00	1.09	1.18	0.47	0.54	0.61	0.68	0.74	0.80
6	0.85	0.99	1.10	1.23	1.35	1.46	0.58	0.67	0.75	0.84	0.92	0.99

Valve size	Evaporator temperature											
	-20°F						-40°F					
	Pressure drop across valve (psi)						Pressure drop across valve (psi)					
	80	100	125	150	175	200	80	100	125	150	175	200
1/4	0.02	0.02	0.02	0.02	0.02	0.03	0.01	0.01	0.01	0.01	0.01	0.02
1/2	0.03	0.04	0.04	0.04	0.05	0.05	0.02	0.02	0.02	0.03	0.03	0.03
1	0.11	0.13	0.14	0.15	0.17	0.18	0.07	0.08	0.09	0.10	0.10	0.11
3	0.24	0.27	0.30	0.33	0.35	0.38	0.15	0.16	0.18	0.20	0.22	0.23
5	0.35	0.39	0.44	0.48	0.52	0.56	0.22	0.24	0.27	0.30	0.32	0.35
6	0.44	0.49	0.54	0.60	0.64	0.69	0.27	0.30	0.34	0.37	0.40	0.43

Note: All capacities shown are at 100% duty cycle (zero reserve capacity). Sizing is recommended for 50-80% duty cycle to accommodate load fluctuations. The refrigerant entering the valve must be in the liquid phase.

### Refrigerant liquid temperature correction factors

Refrigerant liquid temperature °f														
0	10	20	30	40	50	60	70	80	90	100	110	120	130	140
1.89	1.80	1.72	1.63	1.54	1.45	1.36	1.27	1.18	1.09	1.00	0.91	0.82	0.72	0.63

Note: These factors include corrections for liquid refrigerant density and net refrigeration effect, and are based on an average evaporator temperature of 0°F. However, they may be used for any temperature from -40°F to +40°F since the variation in the actual factors across this range is insignificant.

### kW

Valve size	Evaporator temperature											
	10°C						0°C					
	Pressure drop across valve (kPa)						Pressure drop across valve (kPa)					
	400	600	700	800	1000	1100	400	600	700	800	1000	1100
1/4	0.14	0.18	0.19	0.20	0.23	0.24	0.14	0.17	0.19	0.20	0.22	0.23
1/2	0.29	0.35	0.38	0.41	0.46	0.48	0.28	0.34	0.37	0.40	0.44	0.46
1	1.02	1.25	1.35	1.44	1.61	1.69	0.99	1.21	1.31	1.40	1.57	1.64
3	2.14	2.63	2.84	3.03	3.39	3.56	2.08	2.55	2.75	2.94	3.29	3.45
5	3.18	3.90	4.21	4.50	5.04	5.28	3.09	3.78	4.09	4.37	4.88	5.12
6	3.93	4.81	5.19	5.55	6.21	6.51	3.81	4.67	5.04	5.39	6.02	6.32

Valve size	Evaporator temperature											
	-10°C						-20°C					
	Pressure drop across valve (kPa)						Pressure drop across valve (kPa)					
	400	600	700	800	1000	1100	400	600	700	800	1000	1100
1/4	0.11	0.13	0.14	0.15	0.17	0.18	0.07	0.09	0.10	0.10	0.12	0.12
1/2	0.22	0.26	0.28	0.30	0.34	0.36	0.15	0.18	0.19	0.21	0.23	0.24
1	0.76	0.93	1.01	1.08	1.20	1.26	0.52	0.63	0.68	0.73	0.82	0.86
3	1.60	1.96	2.11	2.26	2.53	2.65	1.09	1.33	1.44	1.54	1.72	1.80
5	2.38	2.91	3.14	3.36	3.76	3.94	1.61	1.98	2.13	2.28	2.55	2.68
6	2.93	3.59	3.87	4.14	4.63	4.86	1.99	2.44	2.63	2.81	3.15	3.30

Valve size	Evaporator temperature											
	-30°C						-40°C					
	Pressure drop across valve (kPa)						Pressure drop across valve (kPa)					
	600	700	800	1000	1100	1200	600	700	800	1000	1100	1200
1/4	0.06	0.06	0.07	0.08	0.08	0.08	0.04	0.04	0.04	0.05	0.05	0.05
1/2	0.12	0.13	0.13	0.15	0.16	0.16	0.07	0.08	0.08	0.09	0.10	0.10
1	0.41	0.44	0.48	0.53	0.56	0.58	0.25	0.27	0.29	0.33	0.34	0.36
3	0.87	0.93	1.00	1.12	1.17	1.22	0.53	0.58	0.62	0.69	0.72	0.76
5	1.29	1.39	1.48	1.66	1.74	1.82	0.79	0.86	0.92	1.03	1.08	1.12
6	1.58	1.71	1.83	2.05	2.15	2.24	0.98	1.06	1.13	1.26	1.33	1.39

Expansion valve capacity at 100% duty cycle

Tons

Valve size	Evaporator temperature											
	50°F						40°F					
	Pressure drop across valve (psi)						Pressure drop across valve (psi)					
	60	80	100	125	150	175	60	80	100	125	150	175
1/4	0.03	0.04	0.04	0.05	0.05	0.06	0.03	0.04	0.04	0.05	0.05	0.06
1/2	0.07	0.08	0.08	0.09	0.10	0.11	0.07	0.08	0.09	0.10	0.11	0.11
1	0.23	0.27	0.30	0.34	0.37	0.40	0.24	0.27	0.31	0.34	0.37	0.40
3	0.49	0.56	0.63	0.70	0.77	0.83	0.50	0.57	0.64	0.72	0.79	0.85
5	0.72	0.84	0.94	1.05	1.15	1.24	0.74	0.85	0.95	1.07	1.17	1.26
6	0.89	1.03	1.15	1.29	1.41	1.53	0.91	1.05	1.18	1.31	1.44	1.56

Note: Standard capacity is rated at 100°F liquid inlet and 40°F evaporator temperature; with 100 psi pressure drop across the valve per AHRI 750.

Valve size	Evaporator temperature											
	20°F						0°F					
	Pressure drop across valve (psi)						Pressure drop across valve (psi)					
	60	80	100	125	150	175	60	80	100	125	150	175
1/4	0.02	0.02	0.02	0.03	0.03	0.03	0.01	0.01	0.02	0.02	0.02	0.02
1/2	0.04	0.04	0.05	0.06	0.06	0.07	0.03	0.03	0.03	0.04	0.04	0.04
1	0.13	0.16	0.17	0.19	0.21	0.23	0.09	0.10	0.12	0.13	0.14	0.15
3	0.28	0.33	0.37	0.41	0.45	0.48	0.19	0.22	0.24	0.27	0.30	0.32
5	0.42	0.49	0.54	0.61	0.66	0.72	0.28	0.32	0.36	0.40	0.44	0.48
6	0.52	0.60	0.67	0.75	0.82	0.89	0.34	0.40	0.44	0.50	0.54	0.59

Valve size	Evaporator temperature											
	-20°F						-40°F					
	Pressure drop across valve (psi)						Pressure drop across valve (psi)					
	80	100	125	150	175	200	80	100	125	150	175	200
1/4	0.01	0.01	0.01	0.01	0.01	0.01	0.01	0.01	0.01	0.01	0.01	0.01
1/2	0.02	0.02	0.02	0.03	0.03	0.03	0.01	0.01	0.01	0.02	0.02	0.02
1	0.07	0.07	0.08	0.09	0.10	0.10	0.04	0.04	0.05	0.05	0.06	0.06
3	0.14	0.15	0.17	0.19	0.20	0.22	0.08	0.09	0.10	0.11	0.12	0.13
5	0.20	0.23	0.25	0.28	0.30	0.32	0.12	0.14	0.15	0.17	0.18	0.19
6	0.25	0.28	0.31	0.34	0.37	0.40	0.15	0.17	0.19	0.21	0.22	0.24

Note: All capacities shown are at 100% duty cycle (zero reserve capacity). Sizing is recommended for 50-80% duty cycle to accommodate load fluctuations. The refrigerant entering the valve must be in the liquid phase.

Refrigerant liquid temperature correction factors

Refrigerant liquid temperature °f														
0	10	20	30	40	50	60	70	80	90	100	110	120	130	140
1.74	1.67	1.60	1.52	1.45	1.37	1.30	1.22	1.15	1.08	1.00	0.92	0.85	0.77	0.70

Note: These factors include corrections for liquid refrigerant density and net refrigeration effect, and are based on an average evaporator temperature of 0°F. However, they may be used for any temperature from -40°F to +40°F since the variation in the actual factors across this range is insignificant.

kW

Valve size	Evaporator temperature											
	10°C						0°C					
	Pressure drop across valve (kPa)						Pressure drop across valve (kPa)					
	400	600	700	800	1000	1100	400	600	700	800	1000	1100
1/4	0.11	0.14	0.15	0.16	0.18	0.19	0.11	0.14	0.15	0.16	0.18	0.19
1/2	0.23	0.28	0.30	0.32	0.36	0.37	0.23	0.28	0.30	0.32	0.36	0.38
1	0.80	0.98	1.05	1.13	1.26	1.32	0.81	0.99	1.07	1.15	1.28	1.35
3	1.67	2.05	2.21	2.37	2.65	2.78	1.71	2.09	2.26	2.41	2.70	2.83
5	2.49	3.05	3.29	3.52	3.93	4.12	2.54	3.10	3.35	3.59	4.01	4.20
6	3.07	3.76	4.06	4.34	4.85	5.09	3.13	3.83	4.13	4.42	4.94	5.18

Valve size	Evaporator temperature											
	-10°C						-20°C					
	Pressure drop across valve (kPa)						Pressure drop across valve (kPa)					
	400	600	700	800	1000	1100	400	600	700	800	1000	1100
1/4	0.07	0.08	0.09	0.09	0.10	0.11	0.04	0.05	0.06	0.06	0.07	0.07
1/2	0.13	0.16	0.17	0.18	0.21	0.22	0.09	0.11	0.11	0.12	0.14	0.14
1	0.46	0.57	0.61	0.65	0.73	0.77	0.31	0.38	0.41	0.43	0.48	0.51
3	0.97	1.19	1.29	1.37	1.54	1.61	0.64	0.79	0.85	0.91	1.02	1.07
5	1.44	1.77	1.91	2.04	2.28	2.39	0.96	1.17	1.26	1.35	1.51	1.59
6	1.78	2.18	2.35	2.52	2.81	2.95	1.18	1.44	1.56	1.67	1.86	1.96

Valve size	Evaporator temperature											
	-30°C						-40°C					
	Pressure drop across valve (kPa)						Pressure drop across valve (kPa)					
	600	700	800	1000	1100	1200	600	700	800	1000	1100	1200
1/4	0.03	0.04	0.04	0.04	0.05	0.05	0.02	0.02	0.02	0.03	0.03	0.03
1/2	0.07	0.07	0.08	0.09	0.09	0.09	0.04	0.04	0.05	0.05	0.05	0.06
1	0.24	0.26	0.27	0.31	0.32	0.34	0.14	0.15	0.16	0.18	0.19	0.20
3	0.50	0.54	0.58	0.64	0.67	0.70	0.30	0.32	0.34	0.38	0.40	0.42
5	0.74	0.80	0.85	0.96	1.00	1.05	0.44	0.48	0.51	0.57	0.60	0.63
6	0.91	0.99	1.05	1.18	1.24	1.29	0.55	0.59	0.63	0.70	0.74	0.77

Expansion valve capacity at 100% duty cycle

Tons

Valve size	Evaporator temperature											
	50°F						40°F					
	Pressure drop across valve (psi)						Pressure drop across valve (psi)					
	60	80	100	125	150	175	60	80	100	125	150	175
1/4	0.11	0.13	0.15	0.16	0.18	0.19	0.10	0.12	0.14	0.14	0.16	0.17
1/2	0.23	0.26	0.29	0.33	0.36	0.39	0.20	0.23	0.29	0.29	0.32	0.34
1	0.81	0.94	1.05	1.17	1.28	1.38	0.71	0.82	1.02	1.02	1.12	1.21
3	1.71	1.98	2.21	2.47	2.71	2.92	1.50	1.73	2.17	2.17	2.37	2.56
5	2.55	2.94	3.29	3.67	4.03	4.35	2.23	2.57	3.22	3.22	3.53	3.81
6	3.15	3.64	4.07	4.55	4.98	5.38	2.76	3.19	3.98	3.98	4.36	4.71

Note: Standard capacity is rated at 100°F liquid inlet and 40°F evaporator temperature; with 60 psi pressure drop across the valve per AHRI 750.

Valve size	Evaporator temperature											
	20°F						0°F					
	Pressure drop across valve (psi)						Pressure drop across valve (psi)					
	60	80	100	125	150	175	60	80	100	125	150	175
1/4	0.09	0.10	0.11	0.12	0.14	0.15	0.06	0.07	0.08	0.08	0.09	0.10
1/2	0.17	0.20	0.22	0.25	0.27	0.29	0.12	0.13	0.15	0.17	0.18	0.20
1	0.61	0.71	0.79	0.88	0.97	1.04	0.41	0.48	0.53	0.60	0.65	0.71
3	1.29	1.49	1.67	1.86	2.04	2.20	0.87	1.01	1.13	1.26	1.38	1.49
5	1.92	2.22	2.48	2.77	3.03	3.28	1.30	1.50	1.68	1.87	2.05	2.22
6	2.37	2.74	3.07	3.43	3.75	4.06	1.61	1.86	2.07	2.32	2.54	2.74

Valve size	Evaporator temperature											
	-20°F						-40°F					
	Pressure drop across valve (psi)						Pressure drop across valve (psi)					
	80	100	125	150	175	200	80	100	125	150	175	200
1/4	0.04	0.05	0.05	0.06	0.06	0.07	0.03	0.03	0.03	0.04	0.04	0.04
1/2	0.09	0.10	0.11	0.12	0.13	0.14	0.05	0.06	0.07	0.07	0.08	0.08
1	0.31	0.35	0.39	0.42	0.46	0.49	0.19	0.21	0.24	0.26	0.28	0.30
3	0.65	0.73	0.82	0.89	0.96	1.03	0.40	0.45	0.50	0.55	0.59	0.63
5	0.97	1.08	1.21	1.33	1.43	1.53	0.60	0.67	0.74	0.82	0.88	0.94
6	1.20	1.34	1.50	1.64	1.77	1.90	0.74	0.82	0.92	1.01	1.09	1.16

Note: All capacities shown are at 100% duty cycle (zero reserve capacity). Sizing is recommended for 50-80% duty cycle to accommodate load fluctuations. The refrigerant entering the valve must be in the liquid phase.

Refrigerant liquid temperature correction factors

Refrigerant liquid temperature °f														
0	10	20	30	40	50	60	70	80	90	100	110	120	130	140
1.70	1.63	1.56	1.49	1.42	1.35	1.28	1.21	1.14	1.07	1.00	0.93	0.86	0.78	0.71

Note: These factors include corrections for liquid refrigerant density and net refrigeration effect, and are based on an average evaporator temperature of 0°F. However, they may be used for any temperature from -40°F to +40°F since the variation in the actual factors across this range is insignificant.

kW

Valve size	Evaporator temperature											
	10°C						0°C					
	Pressure drop across valve (kPa)						Pressure drop across valve (kPa)					
	400	600	700	800	1000	1100	400	600	700	800	1000	1100
1/4	0.39	0.48	0.52	0.55	0.62	0.65	0.38	0.47	0.51	0.54	0.61	0.64
1/2	0.78	0.96	1.04	1.11	1.24	1.30	0.77	0.94	1.02	1.09	1.21	1.27
1	2.78	3.41	3.68	3.93	4.40	4.61	2.72	3.34	3.60	3.85	4.31	4.52
3	5.88	7.20	7.78	8.31	9.29	9.75	5.76	7.05	7.61	8.14	9.10	9.54
5	8.74	10.70	11.56	12.36	13.82	14.49	8.56	10.48	11.32	12.10	13.53	14.19
6	10.82	13.25	14.31	15.29	17.10	17.93	10.59	12.97	14.01	14.98	16.75	17.56

Valve size	Evaporator temperature											
	-10°C						-20°C					
	Pressure drop across valve (kPa)						Pressure drop across valve (kPa)					
	400	600	700	800	1000	1100	400	600	700	800	1000	1100
1/4	0.30	0.36	0.39	0.42	0.47	0.49	0.20	0.24	0.26	0.28	0.32	0.33
1/2	0.59	0.72	0.78	0.84	0.93	0.98	0.40	0.49	0.53	0.57	0.63	0.66
1	2.10	2.57	2.77	2.96	3.31	3.48	1.42	1.74	1.88	2.01	2.24	2.35
3	4.43	5.42	5.86	6.26	7.00	7.35	3.00	3.67	3.96	4.24	4.74	4.97
5	6.58	8.06	8.71	9.31	10.41	10.92	4.46	5.46	5.89	6.30	7.04	7.39
6	8.15	9.98	10.78	11.53	12.89	13.52	5.51	6.75	7.29	7.80	8.72	9.14

Valve size	Evaporator temperature											
	-30°C						-40°C					
	Pressure drop across valve (kPa)						Pressure drop across valve (kPa)					
	600	700	800	1000	1100	1200	600	700	800	1000	1100	1200
1/4	0.16	0.17	0.18	0.20	0.21	0.22	0.10	0.10	0.11	0.13	0.13	0.14
1/2	0.32	0.34	0.37	0.41	0.43	0.45	0.19	0.21	0.22	0.25	0.26	0.27
1	1.12	1.21	1.30	1.45	1.52	1.59	0.69	0.75	0.80	0.89	0.93	0.98
3	2.37	2.56	2.74	3.06	3.21	3.36	1.46	1.57	1.68	1.88	1.97	2.06
5	3.53	3.81	4.08	4.56	4.78	4.99	2.17	2.34	2.50	2.80	2.93	3.06
6	4.37	4.72	5.04	5.64	5.91	6.18	2.68	2.90	3.10	3.46	3.63	3.79

Expansion valve capacity at 100% duty cycle

Tons

Valve size	Evaporator temperature											
	50°F						40°F					
	Pressure drop across valve (psi)						Pressure drop across valve (psi)					
	60	80	100	125	150	175	60	80	100	125	150	175
1/4	0.11	0.13	0.14	0.16	0.17	0.19	0.11	0.13	0.14	0.16	0.17	0.19
1/2	0.22	0.25	0.28	0.32	0.35	0.37	0.22	0.25	0.28	0.31	0.34	0.37
1	0.78	0.90	1.00	1.12	1.23	1.33	0.77	0.89	0.99	1.11	1.21	1.31
3	1.63	1.88	2.10	2.35	2.58	2.78	1.61	1.86	2.08	2.33	2.55	2.75
5	2.42	2.80	3.13	3.50	3.83	4.14	2.39	2.76	3.09	3.45	3.78	4.09
6	2.99	3.45	3.86	4.31	4.72	5.10	2.95	3.41	3.81	4.26	4.67	5.04

Note: Standard capacity is rated at 100°F liquid inlet and 40°F evaporator temperature; with 100 psi pressure drop across the valve per AHRI 750.

Valve size	Evaporator temperature											
	20°F						0°F					
	Pressure drop across valve (psi)						Pressure drop across valve (psi)					
	60	80	100	125	150	175	60	80	100	125	150	175
1/4	0.11	0.12	0.14	0.15	0.17	0.18	0.09	0.11	0.12	0.14	0.15	0.16
1/2	0.21	0.24	0.27	0.30	0.33	0.36	0.19	0.22	0.25	0.27	0.30	0.32
1	0.75	0.86	0.96	1.08	1.18	1.28	0.67	0.78	0.87	0.97	1.06	1.15
3	1.57	1.81	2.03	2.27	2.48	2.68	1.41	1.63	1.82	2.04	2.23	2.41
5	2.33	2.69	3.01	3.37	3.69	3.98	2.10	2.42	2.71	3.03	3.31	3.58
6	2.87	3.32	3.71	4.15	4.55	4.91	2.58	2.98	3.34	3.73	4.09	4.41

Valve size	Evaporator temperature											
	-20°F						-40°F					
	Pressure drop across valve (psi)						Pressure drop across valve (psi)					
	80	100	125	150	175	200	80	100	125	150	175	200
1/4	0.08	0.08	0.10	0.10	0.11	0.12	0.05	0.06	0.06	0.07	0.07	0.08
1/2	0.15	0.17	0.19	0.21	0.22	0.24	0.10	0.11	0.13	0.14	0.15	0.16
1	0.54	0.60	0.67	0.74	0.80	0.85	0.36	0.40	0.45	0.49	0.53	0.56
3	1.13	1.26	1.41	1.55	1.67	1.79	0.75	0.84	0.94	1.03	1.11	1.19
5	1.68	1.88	2.10	2.30	2.48	2.65	1.11	1.25	1.39	1.53	1.65	1.76
6	2.07	2.31	2.59	2.83	3.06	3.27	1.37	1.54	1.72	1.88	2.03	2.17

Note: All capacities shown are at 100% duty cycle (zero reserve capacity). Sizing is recommended for 50-80% duty cycle to accommodate load fluctuations. The refrigerant entering the valve must be in the liquid phase.

Refrigerant liquid temperature correction factors

Refrigerant liquid temperature °f														
0	10	20	30	40	50	60	70	80	90	100	110	120	130	140
1.57	1.51	1.46	1.40	1.34	1.29	1.23	1.17	1.12	1.06	1.00	0.94	0.88	0.82	0.76

Note: These factors include corrections for liquid refrigerant density and net refrigeration effect, and are based on an average evaporator temperature of 0°F. However, they may be used for any temperature from -40°F to +40°F since the variation in the actual factors across this range is insignificant.

kW

Valve size	Evaporator temperature											
	10°C						0°C					
	Pressure drop across valve (kPa)						Pressure drop across valve (kPa)					
	400	600	700	800	1000	1100	400	600	700	800	1000	1100
1/4	0.38	0.46	0.50	0.53	0.60	0.62	0.37	0.46	0.49	0.53	0.59	0.62
1/2	0.75	0.92	1.00	1.07	1.19	1.25	0.74	0.91	0.98	1.05	1.18	1.23
1	2.66	3.26	3.52	3.77	4.21	4.42	2.63	3.22	3.48	3.72	4.16	4.36
3	5.60	6.85	7.40	7.91	8.85	9.28	5.53	6.77	7.31	7.82	8.74	9.17
5	8.31	10.18	11.00	11.75	13.14	13.78	8.21	10.06	10.87	11.62	12.99	13.62
6	10.25	12.55	13.56	14.49	16.20	17.00	10.13	12.40	13.40	14.32	16.01	16.80

Valve size	Evaporator temperature											
	-10°C						-20°C					
	Pressure drop across valve (kPa)						Pressure drop across valve (kPa)					
	400	600	700	800	1000	1100	400	600	700	800	1000	1100
1/4	0.36	0.44	0.48	0.51	0.57	0.60	0.33	0.40	0.43	0.46	0.52	0.54
1/2	0.73	0.89	0.96	1.03	1.15	1.20	0.65	0.80	0.86	0.92	1.03	1.08
1	2.56	3.14	3.39	3.63	4.05	4.25	2.31	2.82	3.05	3.26	3.64	3.82
3	5.39	6.60	7.13	7.62	8.52	8.93	4.84	5.93	6.41	6.85	7.66	8.03
5	8.00	9.80	10.58	11.32	12.65	13.27	7.20	8.81	9.52	10.18	11.38	11.93
6	9.87	12.08	13.05	13.95	15.60	16.36	8.87	10.87	11.74	12.55	14.03	14.71

Valve size	Evaporator temperature											
	-30°C						-40°C					
	Pressure drop across valve (kPa)						Pressure drop across valve (kPa)					
	600	700	800	1000	1100	1200	600	700	800	1000	1100	1200
1/4	0.28	0.30	0.32	0.36	0.37	0.39	0.18	0.20	0.21	0.24	0.25	0.26
1/2	0.55	0.60	0.64	0.71	0.75	0.78	0.37	0.40	0.42	0.47	0.50	0.52
1	1.96	2.11	2.26	2.53	2.65	2.77	1.30	1.40	1.50	1.68	1.76	1.84
3	4.11	4.44	4.75	5.31	5.57	5.81	2.73	2.95	3.15	3.52	3.70	3.86
5	6.11	6.60	7.05	7.89	8.27	8.64	4.05	4.38	4.68	5.23	5.49	5.73
6	7.53	8.14	8.70	9.72	10.20	10.65	5.00	5.40	5.77	6.45	6.77	7.07

Expansion valve capacity at 100% duty cycle

Tons

Valve size	Evaporator temperature											
	50°F						40°F					
	Pressure drop across valve (psi)						Pressure drop across valve (psi)					
	60	80	100	125	150	175	60	80	100	125	150	175
1/4	0.10	0.12	0.13	0.15	0.16	0.17	0.10	0.12	0.13	0.14	0.16	0.17
1/2	0.20	0.24	0.26	0.29	0.32	0.35	0.20	0.23	0.26	0.29	0.32	0.34
1	0.72	0.83	0.93	1.04	1.14	1.23	0.71	0.82	0.91	1.02	1.12	1.21
3	1.52	1.75	1.96	2.19	2.40	2.59	1.49	1.72	1.92	2.14	2.35	2.54
5	2.25	2.60	2.91	3.25	3.56	3.85	2.21	2.55	2.85	3.19	3.49	3.77
6	2.78	3.21	3.59	4.01	4.40	4.75	2.72	3.14	3.51	3.93	4.30	4.65

Note: Standard capacity is rated at 100°F liquid inlet and 40°F evaporator temperature; with 100 psi pressure drop across the valve per AHRI 750.

Valve size	Evaporator temperature											
	20°F						0°F					
	Pressure drop across valve (psi)						Pressure drop across valve (psi)					
	60	80	100	125	150	175	60	80	100	125	150	175
1/4	0.10	0.11	0.12	0.14	0.15	0.16	0.08	0.09	0.10	0.11	0.12	0.13
1/2	0.19	0.22	0.25	0.28	0.30	0.33	0.16	0.18	0.20	0.22	0.25	0.27
1	0.68	0.78	0.87	0.98	1.07	1.15	0.55	0.64	0.71	0.79	0.87	0.94
3	1.42	1.64	1.83	2.05	2.25	2.43	1.16	1.33	1.49	1.67	1.83	1.97
5	2.11	2.44	2.72	3.05	3.34	3.60	1.72	1.98	2.22	2.48	2.71	2.93
6	2.60	3.00	3.36	3.76	4.11	4.44	2.12	2.44	2.73	3.05	3.35	3.61

Valve size	Evaporator temperature											
	-20°F						-40°F					
	Pressure drop across valve (psi)						Pressure drop across valve (psi)					
	80	100	125	150	175	200	80	100	125	150	175	200
1/4	0.06	0.07	0.08	0.09	0.09	0.10	0.04	0.05	0.05	0.06	0.06	0.07
1/2	0.13	0.14	0.16	0.17	0.19	0.20	0.08	0.09	0.10	0.11	0.12	0.13
1	0.44	0.50	0.55	0.61	0.65	0.70	0.30	0.33	0.37	0.41	0.44	0.47
3	0.93	1.04	1.16	1.27	1.38	1.47	0.62	0.70	0.78	0.85	0.92	0.98
5	1.38	1.55	1.73	1.89	2.04	2.19	0.93	1.03	1.16	1.27	1.37	1.46
6	1.70	1.91	2.13	2.33	2.52	2.69	1.14	1.28	1.43	1.56	1.69	1.80

Note: All capacities shown are at 100% duty cycle (zero reserve capacity). Sizing is recommended for 50-80% duty cycle to accommodate load fluctuations. The refrigerant entering the valve must be in the liquid phase.

Refrigerant liquid temperature correction factors

Refrigerant liquid temperature °f														
0	10	20	30	40	50	60	70	80	90	100	110	120	130	140
1.70	1.63	1.56	1.49	1.42	1.36	1.29	1.22	1.14	1.07	1.00	0.93	0.85	0.78	0.70

Note: These factors include corrections for liquid refrigerant density and net refrigeration effect, and are based on an average evaporator temperature of 0°F. However, they may be used for any temperature from -40°F to +40°F since the variation in the actual factors across this range is insignificant.

kW

Valve size	Evaporator temperature											
	10°C						0°C					
	Pressure drop across valve (kPa)						Pressure drop across valve (kPa)					
	400	600	700	800	1000	1100	400	600	700	800	1000	1100
1/4	0.35	0.43	0.46	0.50	0.55	0.58	0.34	0.42	0.45	0.49	0.54	0.57
1/2	0.70	0.86	0.93	0.99	1.11	1.16	0.69	0.84	0.91	0.97	1.09	1.14
1	2.48	3.04	3.28	3.51	3.92	4.11	2.43	2.97	3.21	3.43	3.84	4.03
3	5.21	6.38	6.89	7.37	8.24	8.64	5.10	6.25	6.75	7.21	8.06	8.46
5	7.74	9.48	10.24	10.94	12.23	12.83	7.58	9.28	10.02	10.71	11.98	12.56
6	9.54	11.69	12.62	13.49	15.09	15.82	9.34	11.44	12.36	13.21	14.77	15.49

Valve size	Evaporator temperature											
	-10°C						-20°C					
	Pressure drop across valve (kPa)						Pressure drop across valve (kPa)					
	400	600	700	800	1000	1100	400	600	700	800	1000	1100
1/4	0.33	0.40	0.43	0.46	0.52	0.54	0.27	0.33	0.35	0.38	0.42	0.44
1/2	0.66	0.80	0.87	0.93	1.04	1.09	0.53	0.65	0.71	0.75	0.84	0.89
1	2.32	2.84	3.07	3.28	3.67	3.85	1.89	2.31	2.50	2.67	2.98	3.13
3	4.88	5.97	6.45	6.89	7.71	8.08	3.97	4.86	5.25	5.61	6.27	6.58
5	7.24	8.87	9.58	10.24	11.45	12.01	5.89	7.22	7.79	8.33	9.31	9.77
6	8.93	10.94	11.81	12.63	14.12	14.81	7.26	8.90	9.61	10.27	11.49	12.05

Valve size	Evaporator temperature											
	-30°C						-40°C					
	Pressure drop across valve (kPa)						Pressure drop across valve (kPa)					
	600	700	800	1000	1100	1200	600	700	800	1000	1100	1200
1/4	0.23	0.25	0.26	0.29	0.31	0.32	0.15	0.16	0.18	0.20	0.21	0.22
1/2	0.46	0.49	0.53	0.59	0.62	0.64	0.31	0.33	0.35	0.39	0.41	0.43
1	1.61	1.74	1.86	2.08	2.18	2.28	1.08	1.17	1.25	1.39	1.46	1.53
3	3.39	3.66	3.91	4.37	4.59	4.79	2.27	2.45	2.62	2.93	3.07	3.21
5	5.03	5.43	5.81	6.50	6.81	7.12	3.37	3.64	3.89	4.35	4.56	4.76
6	6.20	6.70	7.16	8.01	8.40	8.77	4.15	4.49	4.80	5.36	5.62	5.87

Expansion valve capacity at 100% duty cycle

Tons

Valve size	Evaporator temperature											
	50°F						40°F					
	Pressure drop across valve (psi)						Pressure drop across valve (psi)					
	60	80	100	125	150	175	60	80	100	125	150	175
1/4	0.19	0.22	0.24	0.27	0.30	0.32	0.19	0.22	0.24	0.27	0.30	0.32
1/2	0.38	0.43	0.49	0.54	0.60	0.64	0.38	0.43	0.48	0.54	0.59	0.64
1	1.33	1.54	1.72	1.92	2.10	2.27	1.33	1.53	1.71	1.92	2.10	2.27
3	2.80	3.23	3.61	4.04	4.42	4.78	2.79	3.22	3.60	4.03	4.41	4.76
5	4.15	4.80	5.36	6.00	6.57	7.09	4.14	4.78	5.35	5.98	6.55	7.08
6	5.12	5.91	6.61	7.39	8.10	8.75	5.11	5.90	6.60	7.37	8.08	8.72

Note: Standard capacity is rated at 100°F liquid inlet and 40°F evaporator temperature; with 100 psi pressure drop across the valve per AHRI 750.

Valve size	Evaporator temperature											
	20°F						0°F					
	Pressure drop across valve (psi)						Pressure drop across valve (psi)					
	60	80	100	125	150	175	60	80	100	125	150	175
1/4	0.19	0.21	0.24	0.27	0.29	0.32	0.18	0.21	0.24	0.27	0.29	0.31
1/2	0.37	0.43	0.48	0.54	0.59	0.64	0.37	0.42	0.47	0.53	0.58	0.63
1	1.32	1.52	1.70	1.90	2.08	2.25	1.30	1.50	1.68	1.87	2.05	2.22
3	2.76	3.19	3.57	3.99	4.37	4.72	2.73	3.15	3.52	3.94	4.31	4.66
5	4.11	4.74	5.30	5.93	6.49	7.01	4.05	4.68	5.23	5.85	6.41	6.92
6	5.06	5.85	6.54	7.31	8.01	8.65	5.00	5.77	6.45	7.21	7.90	8.53

Valve size	Evaporator temperature											
	-20°F						-40°F					
	Pressure drop across valve (psi)						Pressure drop across valve (psi)					
	80	100	125	150	175	200	80	100	125	150	175	200
1/4	0.21	0.23	0.26	0.29	0.31	0.33	0.15	0.17	0.19	0.21	0.23	0.24
1/2	0.42	0.47	0.52	0.57	0.62	0.66	0.31	0.34	0.38	0.42	0.45	0.48
1	1.47	1.65	1.84	2.02	2.18	2.33	1.08	1.21	1.35	1.48	1.60	1.71
3	3.10	3.46	3.87	4.24	4.58	4.90	2.27	2.54	2.84	3.11	3.36	3.59
5	4.60	5.15	5.75	6.30	6.81	7.28	3.38	3.77	4.22	4.62	4.99	5.34
6	5.67	6.34	7.09	7.77	8.39	8.97	4.16	4.65	5.20	5.70	6.16	6.58

Note: All capacities shown are at 100% duty cycle (zero reserve capacity). Sizing is recommended for 50-80% duty cycle to accommodate load fluctuations. The refrigerant entering the valve must be in the liquid phase.

Refrigerant liquid temperature correction factors

Refrigerant liquid temperature °f														
0	10	20	30	40	50	60	70	80	90	100	110	120	130	140
1.58	1.52	1.47	1.41	1.36	1.30	1.24	1.18	1.12	1.06	1.00	0.94	0.87	0.80	0.73

Note: These factors include corrections for liquid refrigerant density and net refrigeration effect, and are based on an average evaporator temperature of 0°F. However, they may be used for any temperature from -40°F to +40°F since the variation in the actual factors across this range is insignificant.

kW

Valve size	Evaporator temperature											
	10°C						0°C					
	Pressure drop across valve (kPa)						Pressure drop across valve (kPa)					
	400	600	700	800	1000	1100	400	600	700	800	1000	1100
1/4	0.65	0.79	0.85	0.91	1.02	1.07	0.64	0.79	0.85	0.91	1.02	1.07
1/2	1.29	1.58	1.71	1.83	2.04	2.14	1.29	1.58	1.70	1.82	2.04	2.14
1	4.57	5.59	6.04	6.46	7.22	7.57	4.56	5.58	6.03	6.44	7.20	7.55
3	9.60	11.75	12.69	13.57	15.17	15.91	9.57	11.72	12.66	13.54	15.13	15.87
5	14.26	17.46	18.86	20.16	22.54	23.64	14.22	17.42	18.81	20.11	22.48	23.58
6	17.58	21.53	23.25	24.86	27.79	29.15	17.53	21.47	23.19	24.80	27.72	29.07

Valve size	Evaporator temperature											
	-10°C						-20°C					
	Pressure drop across valve (kPa)						Pressure drop across valve (kPa)					
	400	600	700	800	1000	1100	400	600	700	800	1000	1100
1/4	0.64	0.78	0.84	0.90	1.01	1.06	0.63	0.77	0.83	0.89	1.00	1.05
1/2	1.28	1.56	1.69	1.81	2.02	2.12	1.26	1.54	1.67	1.78	1.99	2.09
1	4.52	5.53	5.97	6.39	7.14	7.49	4.46	5.46	5.90	6.30	7.05	7.39
3	9.49	11.62	12.55	13.42	15.00	15.73	9.36	11.47	12.39	13.24	14.81	15.53
5	14.09	17.26	18.64	19.93	22.28	23.37	13.91	17.04	18.40	19.67	21.99	23.07
6	17.38	21.28	22.99	24.58	27.48	28.82	17.15	21.01	22.69	24.26	27.12	28.44

Valve size	Evaporator temperature											
	-30°C						-40°C					
	Pressure drop across valve (kPa)						Pressure drop across valve (kPa)					
	600	700	800	1000	1100	1200	600	700	800	1000	1100	1200
1/4	0.76	0.82	0.88	0.98	1.03	1.07	0.56	0.60	0.64	0.72	0.75	0.79
1/2	1.52	1.64	1.75	1.96	2.06	2.15	1.11	1.20	1.29	1.44	1.51	1.57
1	5.37	5.80	6.20	6.93	7.27	7.59	3.94	4.25	4.55	5.08	5.33	5.57
3	11.28	12.18	13.02	14.56	15.27	15.95	8.27	8.93	9.55	10.68	11.20	11.70
5	16.75	18.10	19.34	21.63	22.68	23.69	12.29	13.27	14.19	15.86	16.64	17.38
6	20.66	22.31	23.85	26.67	27.97	29.21	15.15	16.36	17.49	19.56	20.51	21.42

Expansion valve capacity at 100% duty cycle

Tons

Valve size	Evaporator temperature											
	50°F						40°F					
	Pressure drop across valve (psi)						Pressure drop across valve (psi)					
	60	80	100	125	150	175	60	80	100	125	150	175
1/4	0.07	0.09	0.10	0.11	0.12	0.13	0.07	0.08	0.09	0.10	0.11	0.12
1/2	0.14	0.16	0.18	0.20	0.22	0.24	0.14	0.16	0.18	0.20	0.22	0.24
1	0.50	0.58	0.65	0.73	0.80	0.86	0.49	0.57	0.64	0.71	0.78	0.84
3	1.06	1.23	1.37	1.53	1.68	1.82	1.04	1.20	1.34	1.50	1.64	1.77
5	1.58	1.83	2.04	2.29	2.50	2.70	1.55	1.79	2.00	2.23	2.45	2.64
6	1.95	2.25	2.52	2.82	3.09	3.34	1.91	2.20	2.46	2.75	3.02	3.26

Note: Standard capacity is rated at 100°F liquid inlet and 40°F evaporator temperature; with 100 psi pressure drop across the valve per AHRI 750.

kW

Valve size	Evaporator temperature											
	10°C						0°C					
	Pressure drop across valve (kPa)						Pressure drop across valve (kPa)					
	400	600	700	800	1000	1100	400	600	700	800	1000	1100
1/4	0.25	0.31	0.33	0.36	0.40	0.42	0.25	0.30	0.33	0.35	0.39	0.41
1/2	0.49	0.60	0.64	0.69	0.77	0.81	0.48	0.58	0.63	0.67	0.75	0.79
1	1.73	2.12	2.29	2.45	2.74	2.87	1.69	2.07	2.24	2.39	2.67	2.80
3	3.65	4.47	4.83	5.16	5.77	6.05	3.57	4.37	4.72	5.04	5.64	5.91
5	5.43	6.66	7.19	7.69	8.59	9.01	5.31	6.51	7.03	7.51	8.40	8.81
6	6.70	8.21	8.87	9.48	10.60	11.11	6.55	8.02	8.67	9.26	10.36	10.86

Valve size	Evaporator temperature											
	20°F						0°F					
	Pressure drop across valve (psi)						Pressure drop across valve (psi)					
	60	80	100	125	150	175	60	80	100	125	150	175
1/4	0.07	0.08	0.09	0.10	0.11	0.12	0.06	0.07	0.08	0.09	0.10	0.11
1/2	0.13	0.15	0.17	0.19	0.21	0.22	0.12	0.14	0.16	0.18	0.20	0.21
1	0.47	0.54	0.60	0.68	0.74	0.80	0.44	0.51	0.57	0.64	0.70	0.75
3	0.99	1.14	1.27	1.42	1.56	1.69	0.93	1.07	1.20	1.34	1.47	1.59
5	1.47	1.70	1.90	2.12	2.32	2.51	1.39	1.60	1.79	2.00	2.19	2.37
6	1.81	2.09	2.34	2.62	2.87	3.10	1.71	1.98	2.21	2.47	2.70	2.92

Valve size	Evaporator temperature											
	-10°C						-20°C					
	Pressure drop across valve (kPa)						Pressure drop across valve (kPa)					
	400	600	700	800	1000	1100	400	600	700	800	1000	1100
1/4	0.23	0.29	0.31	0.33	0.37	0.39	0.22	0.27	0.29	0.31	0.35	0.37
1/2	0.45	0.55	0.60	0.64	0.71	0.75	0.43	0.52	0.56	0.60	0.67	0.71
1	1.61	1.97	2.12	2.27	2.54	2.66	1.52	1.86	2.00	2.14	2.40	2.51
3	3.39	4.15	4.48	4.79	5.35	5.62	3.19	3.91	4.23	4.52	5.05	5.30
5	5.05	6.18	6.68	7.14	7.98	8.37	4.76	5.83	6.30	6.73	7.53	7.89
6	6.22	7.62	8.23	8.80	9.84	10.32	5.87	7.19	7.77	8.30	9.28	9.73

Valve size	Evaporator temperature											
	-20°F						-40°F					
	Pressure drop across valve (psi)						Pressure drop across valve (psi)					
	80	100	125	150	175	200	80	100	125	150	175	200
1/4	0.06	0.06	0.07	0.08	0.08	0.09	0.04	0.04	0.05	0.05	0.05	0.06
1/2	0.11	0.12	0.13	0.15	0.16	0.17	0.07	0.08	0.09	0.10	0.10	0.11
1	0.38	0.43	0.48	0.52	0.56	0.60	0.25	0.28	0.31	0.34	0.36	0.39
3	0.80	0.90	1.01	1.10	1.19	1.27	0.52	0.58	0.65	0.71	0.77	0.82
5	1.20	1.34	1.50	1.64	1.77	1.90	0.78	0.87	0.97	1.06	1.15	1.23
6	1.48	1.65	1.85	2.02	2.19	2.34	0.96	1.07	1.19	1.31	1.41	1.51

Valve size	Evaporator temperature											
	-30°C						-40°C					
	Pressure drop across valve (kPa)						Pressure drop across valve (kPa)					
	600	700	800	1000	1100	1200	600	700	800	1000	1100	1200
1/4	0.20	0.22	0.23	0.26	0.28	0.29	0.13	0.14	0.15	0.17	0.18	0.19
1/2	0.39	0.42	0.45	0.50	0.53	0.55	0.25	0.27	0.29	0.33	0.34	0.36
1	1.39	1.50	1.60	1.79	1.88	1.96	0.90	0.97	1.04	1.16	1.22	1.27
3	2.93	3.16	3.38	3.78	3.97	4.14	1.89	2.05	2.19	2.44	2.56	2.68
5	4.36	4.71	5.04	5.63	5.91	6.17	2.82	3.05	3.26	3.64	3.82	3.99
6	5.38	5.81	6.22	6.95	7.29	7.61	3.48	3.76	4.02	4.49	4.71	4.92

Note: All capacities shown are at 100% duty cycle (zero reserve capacity). Sizing is recommended for 50-80% duty cycle to accommodate load fluctuations. The refrigerant entering the valve must be in the liquid phase.

Refrigerant liquid temperature correction factors

Refrigerant liquid temperature °f														
0	10	20	30	40	50	60	70	80	90	100	110	120	130	140
2.01	1.92	1.82	1.72	1.62	1.52	1.42	1.31	1.21	1.11	1.00	0.89	0.78	0.66	0.54

Note: These factors include corrections for liquid refrigerant density and net refrigeration effect, and are based on an average evaporator temperature of 0°F. However, they may be used for any temperature from -40°F to +40°F since the variation in the actual factors across this range is insignificant.

Expansion valve capacity at 100% duty cycle

Tons

Valve size	Evaporator temperature											
	50°F						40°F					
	Pressure drop across valve (psi)						Pressure drop across valve (psi)					
	60	80	100	125	150	175	60	80	100	125	150	175
1/4	0.10	0.12	0.13	0.15	0.16	0.17	0.10	0.12	0.13	0.15	0.16	0.17
1/2	0.19	0.22	0.24	0.27	0.30	0.32	0.19	0.21	0.24	0.27	0.29	0.32
1	0.67	0.77	0.86	0.97	1.06	1.14	0.66	0.76	0.85	0.95	1.04	1.12
3	1.42	1.64	1.83	2.05	2.24	2.42	1.39	1.61	1.80	2.01	2.20	2.38
5	2.11	2.44	2.73	3.05	3.34	3.61	2.08	2.40	2.68	3.00	3.28	3.55
6	2.61	3.01	3.37	3.76	4.12	4.45	2.56	2.96	3.31	3.70	4.05	4.38

Note: Standard capacity is rated at 100°F liquid inlet and 40°F evaporator temperature; with 100 psi pressure drop across the valve per AHRI 750.

Valve size	Evaporator temperature											
	20°F						0°F					
	Pressure drop across valve (psi)						Pressure drop across valve (psi)					
	60	80	100	125	150	175	60	80	100	125	150	175
1/4	0.10	0.11	0.13	0.14	0.15	0.17	0.09	0.10	0.11	0.13	0.14	0.15
1/2	0.18	0.21	0.23	0.26	0.28	0.31	0.16	0.19	0.21	0.24	0.26	0.28
1	0.63	0.73	0.82	0.91	1.00	1.08	0.58	0.67	0.75	0.84	0.92	0.99
3	1.34	1.55	1.73	1.94	2.12	2.29	1.23	1.42	1.58	1.77	1.94	2.10
5	2.00	2.31	2.58	2.88	3.16	3.41	1.83	2.11	2.36	2.64	2.89	3.12
6	2.47	2.85	3.19	3.56	3.90	4.21	2.26	2.61	2.91	3.26	3.57	3.85

Valve size	Evaporator temperature											
	-20°F						-40°F					
	Pressure drop across valve (psi)						Pressure drop across valve (psi)					
	80	100	125	150	175	200	80	100	125	150	175	200
1/4	0.07	0.08	0.09	0.09	0.10	0.11	0.04	0.05	0.05	0.06	0.06	0.07
1/2	0.13	0.14	0.16	0.17	0.19	0.20	0.08	0.09	0.10	0.11	0.12	0.13
1	0.45	0.50	0.56	0.61	0.66	0.70	0.28	0.31	0.35	0.39	0.42	0.45
3	0.94	1.05	1.18	1.29	1.39	1.49	0.60	0.67	0.75	0.82	0.88	0.94
5	1.40	1.57	1.75	1.92	2.08	2.22	0.89	0.99	1.11	1.22	1.31	1.40
6	1.73	1.94	2.17	2.37	2.56	2.74	1.10	1.23	1.37	1.50	1.62	1.73

Note: All capacities shown are at 100% duty cycle (zero reserve capacity). Sizing is recommended for 50-80% duty cycle to accommodate load fluctuations. The refrigerant entering the valve must be in the liquid phase.

Refrigerant liquid temperature correction factors

Refrigerant liquid temperature °f														
0	10	20	30	40	50	60	70	80	90	100	110	120	130	140
1.78	1.70	1.63	1.55	1.47	1.40	1.32	1.24	1.16	1.08	1.00	0.92	0.83	0.75	0.66

Note: These factors include corrections for liquid refrigerant density and net refrigeration effect, and are based on an average evaporator temperature of 0°F. However, they may be used for any temperature from -40°F to +40°F since the variation in the actual factors across this range is insignificant.

kW

Valve size	Evaporator temperature											
	10°C						0°C					
	Pressure drop across valve (kPa)						Pressure drop across valve (kPa)					
	400	600	700	800	1000	1100	400	600	700	800	1000	1100
1/4	0.35	0.43	0.47	0.50	0.56	0.58	0.35	0.42	0.46	0.49	0.55	0.57
1/2	0.65	0.79	0.86	0.92	1.03	1.08	0.64	0.78	0.84	0.90	1.01	1.06
1	2.30	2.82	3.04	3.25	3.63	3.81	2.26	2.77	2.99	3.20	3.57	3.75
3	4.87	5.96	6.44	6.88	7.70	8.07	4.79	5.86	6.33	6.77	7.57	7.94
5	7.25	8.88	9.59	10.25	11.46	12.02	7.12	8.73	9.43	10.08	11.27	11.82
6	8.95	10.96	11.84	12.66	14.15	14.85	8.80	10.78	11.64	12.44	13.91	14.59

Valve size	Evaporator temperature											
	-10°C						-20°C					
	Pressure drop across valve (kPa)						Pressure drop across valve (kPa)					
	400	600	700	800	1000	1100	400	600	700	800	1000	1100
1/4	0.33	0.41	0.44	0.47	0.53	0.55	0.30	0.37	0.40	0.43	0.48	0.50
1/2	0.61	0.75	0.81	0.87	0.97	1.02	0.56	0.69	0.74	0.79	0.89	0.93
1	2.18	2.66	2.88	3.08	3.44	3.61	1.99	2.44	2.63	2.81	3.14	3.30
3	4.61	5.64	6.09	6.51	7.28	7.64	4.21	5.16	5.57	5.96	6.66	6.98
5	6.86	8.40	9.07	9.70	10.84	11.37	6.27	7.68	8.29	8.87	9.91	10.40
6	8.47	10.37	11.20	11.98	13.39	14.05	7.74	9.48	10.24	10.95	12.24	12.84

Valve size	Evaporator temperature											
	-30°C						-40°C					
	Pressure drop across valve (kPa)						Pressure drop across valve (kPa)					
	600	700	800	1000	1100	1200	600	700	800	1000	1100	1200
1/4	0.25	0.27	0.29	0.32	0.34	0.35	0.16	0.17	0.18	0.20	0.21	0.22
1/2	0.46	0.49	0.53	0.59	0.62	0.65	0.29	0.31	0.33	0.37	0.39	0.41
1	1.62	1.75	1.87	2.09	2.19	2.29	1.02	1.11	1.18	1.32	1.39	1.45
3	3.43	3.71	3.96	4.43	4.65	4.85	2.17	2.34	2.51	2.80	2.94	3.07
5	5.11	5.52	5.90	6.59	6.92	7.22	3.23	3.49	3.73	4.17	4.37	4.57
6	6.31	6.81	7.28	8.14	8.54	8.92	3.99	4.31	4.61	5.15	5.40	5.64

Expansion valve capacity at 100% duty cycle

Tons

Valve size	Evaporator temperature											
	50°F						40°F					
	Pressure drop across valve (psi)						Pressure drop across valve (psi)					
	60	80	100	125	150	175	60	80	100	125	150	175
1/4	0.11	0.13	0.14	0.16	0.17	0.19	0.11	0.13	0.14	0.16	0.17	0.19
1/2	0.20	0.24	0.26	0.30	0.32	0.35	0.20	0.23	0.26	0.29	0.32	0.34
1	0.73	0.85	0.95	1.06	1.16	1.25	0.72	0.83	0.93	1.04	1.14	1.23
3	1.54	1.77	1.98	2.22	2.43	2.62	1.51	1.74	1.95	2.18	2.39	2.58
5	2.29	2.65	2.96	3.31	3.62	3.91	2.25	2.60	2.91	3.25	3.56	3.85
6	2.83	3.26	3.65	4.08	4.47	4.83	2.78	3.21	3.59	4.01	4.40	4.75

Note: Standard capacity is rated at 100°F liquid inlet and 40°F evaporator temperature; with 100 psi pressure drop across the valve per AHRI 750.

Valve size	Evaporator temperature											
	20°F						0°F					
	Pressure drop across valve (psi)						Pressure drop across valve (psi)					
	60	80	100	125	150	175	60	80	100	125	150	175
1/4	0.10	0.12	0.14	0.15	0.17	0.18	0.09	0.10	0.12	0.13	0.14	0.15
1/2	0.19	0.22	0.25	0.28	0.31	0.33	0.17	0.19	0.21	0.24	0.26	0.28
1	0.70	0.80	0.90	1.00	1.10	1.19	0.59	0.68	0.76	0.85	0.94	1.01
3	1.46	1.68	1.88	2.10	2.30	2.49	1.24	1.43	1.60	1.79	1.96	2.12
5	2.18	2.51	2.81	3.14	3.44	3.71	1.85	2.14	2.39	2.67	2.93	3.17
6	2.68	3.10	3.46	3.87	4.24	4.58	2.29	2.64	2.95	3.30	3.62	3.90

Valve size	Evaporator temperature											
	-20°F						-40°F					
	Pressure drop across valve (psi)						Pressure drop across valve (psi)					
	80	100	125	150	175	200	80	100	125	150	175	200
1/4	0.07	0.08	0.09	0.09	0.10	0.11	0.04	0.05	0.05	0.06	0.06	0.07
1/2	0.13	0.14	0.16	0.17	0.19	0.20	0.08	0.09	0.10	0.11	0.12	0.13
1	0.45	0.51	0.57	0.62	0.67	0.72	0.29	0.32	0.36	0.39	0.42	0.45
3	0.95	1.06	1.19	1.30	1.41	1.51	0.60	0.67	0.75	0.82	0.89	0.95
5	1.42	1.59	1.78	1.95	2.10	2.25	0.90	1.00	1.12	1.23	1.33	1.42
6	1.75	1.96	2.19	2.40	2.59	2.77	1.11	1.24	1.38	1.51	1.64	1.75

Note: All capacities shown are at 100% duty cycle (zero reserve capacity). Sizing is recommended for 50-80% duty cycle to accommodate load fluctuations. The refrigerant entering the valve must be in the liquid phase.

Refrigerant liquid temperature correction factors

Refrigerant liquid temperature °f														
0	10	20	30	40	50	60	70	80	90	100	110	120	130	140
1.72	1.65	1.58	1.51	1.44	1.37	1.29	1.22	1.15	1.07	1.00	0.92	0.85	0.77	0.69

Note: These factors include corrections for liquid refrigerant density and net refrigeration effect, and are based on an average evaporator temperature of 0°F. However, they may be used for any temperature from -40°F to +40°F since the variation in the actual factors across this range is insignificant.

kW

Valve size	Evaporator temperature											
	10°C						0°C					
	Pressure drop across valve (kPa)						Pressure drop across valve (kPa)					
	400	600	700	800	1000	1100	400	600	700	800	1000	1100
1/4	0.38	0.46	0.50	0.53	0.60	0.63	0.37	0.46	0.49	0.53	0.59	0.62
1/2	0.70	0.86	0.93	0.99	1.11	1.16	0.69	0.85	0.91	0.98	1.09	1.15
1	2.51	3.08	3.32	3.55	3.97	4.17	2.47	3.03	3.27	3.50	3.91	4.10
3	5.27	6.45	6.97	7.45	8.33	8.74	5.18	6.35	6.86	7.33	8.20	8.60
5	7.86	9.63	10.40	11.12	12.43	13.04	7.74	9.47	10.23	10.94	12.23	12.83
6	9.70	11.88	12.83	13.72	15.34	16.09	9.54	11.69	12.63	13.50	15.09	15.83

Valve size	Evaporator temperature											
	-10°C						-20°C					
	Pressure drop across valve (kPa)						Pressure drop across valve (kPa)					
	400	600	700	800	1000	1100	400	600	700	800	1000	1100
1/4	0.36	0.44	0.48	0.51	0.57	0.60	0.31	0.37	0.40	0.43	0.48	0.51
1/2	0.67	0.82	0.88	0.94	1.05	1.11	0.57	0.70	0.75	0.80	0.90	0.94
1	2.39	2.92	3.16	3.37	3.77	3.96	2.03	2.49	2.69	2.87	3.21	3.37
3	5.00	6.13	6.62	7.07	7.91	8.30	4.26	5.22	5.64	6.03	6.74	7.07
5	7.47	9.14	9.88	10.56	11.80	12.38	6.36	7.79	8.41	9.00	10.06	10.55
6	9.21	11.28	12.18	13.03	14.56	15.27	7.85	9.61	10.38	11.10	12.41	13.01

Valve size	Evaporator temperature											
	-30°C						-40°C					
	Pressure drop across valve (kPa)						Pressure drop across valve (kPa)					
	600	700	800	1000	1100	1200	600	700	800	1000	1100	1200
1/4	0.25	0.27	0.29	0.32	0.34	0.35	0.16	0.17	0.18	0.20	0.21	0.22
1/2	0.46	0.50	0.53	0.60	0.63	0.65	0.29	0.32	0.34	0.38	0.39	0.41
1	1.65	1.79	1.91	2.13	2.24	2.34	1.04	1.13	1.20	1.35	1.41	1.48
3	3.47	3.74	4.00	4.47	4.69	4.90	2.19	2.36	2.53	2.82	2.96	3.09
5	5.17	5.59	5.97	6.68	7.00	7.31	3.26	3.53	3.77	4.21	4.42	4.62
6	6.38	6.89	7.37	8.24	8.64	9.02	4.03	4.35	4.65	5.20	5.45	5.70

Expansion valve capacity at 100% duty cycle

Tons

Valve size	Evaporator temperature											
	50°F						40°F					
	Pressure drop across valve (psi)						Pressure drop across valve (psi)					
	110	140	160	210	245	285	110	140	160	210	245	285
1/4	0.14	0.16	0.17	0.20	0.21	0.23	0.14	0.16	0.17	0.19	0.21	0.23
1/2	0.28	0.31	0.33	0.38	0.41	0.44	0.27	0.31	0.33	0.38	0.41	0.44
1	0.97	1.09	1.17	1.34	1.45	1.56	0.96	1.09	1.16	1.33	1.44	1.55
3	2.05	2.31	2.47	2.83	3.06	3.30	2.03	2.29	2.45	2.81	3.03	3.27
5	3.05	3.44	3.68	4.22	4.56	4.91	3.03	3.41	3.65	4.18	4.52	4.87
6	3.77	4.25	4.55	5.21	5.63	6.07	3.74	4.22	4.51	5.17	5.58	6.02

Note: Standard capacity is rated at 100°F liquid inlet and 40°F evaporator temperature; with 100 psi pressure drop across the valve per AHRI 750.

Valve size	Evaporator temperature											
	20°F						0°F					
	Pressure drop across valve (psi)						Pressure drop across valve (psi)					
	110	140	160	210	245	285	140	160	210	245	285	330
1/4	0.14	0.16	0.17	0.19	0.21	0.22	0.35	0.39	0.42	0.48	0.52	0.56
1/2	0.27	0.30	0.32	0.37	0.40	0.43	0.61	0.68	0.73	0.84	0.90	0.97
1	0.94	1.06	1.14	1.30	1.40	1.51	0.96	1.09	1.16	1.33	1.44	1.55
3	1.99	2.24	2.40	2.75	2.97	3.20	1.38	1.56	1.67	1.91	2.07	2.23
5	2.96	3.34	3.57	4.09	4.42	4.77	2.04	2.30	2.46	2.82	3.04	3.28
6	3.66	4.13	4.41	5.06	5.46	5.89	4.16	4.70	5.02	5.75	6.21	6.70

Valve size	Evaporator temperature											
	-20°F						-40°F					
	Pressure drop across valve (psi)						Pressure drop across valve (psi)					
	110	140	160	210	245	285	140	160	210	245	285	330
1/4	0.24	0.26	0.29	0.32	0.34	0.37	0.16	0.17	0.20	0.21	0.23	0.25
1/2	0.41	0.44	0.50	0.54	0.58	0.63	0.27	0.29	0.33	0.36	0.39	0.41
1	0.66	0.71	0.81	0.87	0.94	1.01	0.44	0.47	0.54	0.58	0.63	0.68
3	0.95	1.02	1.16	1.26	1.36	1.46	0.63	0.67	0.77	0.83	0.90	0.97
5	1.40	1.50	1.71	1.85	2.00	2.15	0.93	0.99	1.14	1.23	1.33	1.43
6	2.85	3.05	3.49	3.77	4.07	4.38	1.89	2.02	2.31	2.50	2.70	2.90

Note: All capacities shown are at 100% duty cycle (zero reserve capacity). Sizing is recommended for 50-80% duty cycle to accommodate load fluctuations. The refrigerant entering the valve must be in the liquid phase.

Refrigerant liquid temperature correction factors

Refrigerant liquid temperature °F														
0	10	20	30	40	50	60	70	80	90	100	110	120	130	140
1.77	1.69	1.62	1.55	1.47	1.40	1.32	1.24	1.16	1.08	1.00	0.92	0.83	0.74	0.63

Note: These factors include corrections for liquid refrigerant density and net refrigeration effect, and are based on an average evaporator temperature of 0°F. However, they may be used for any temperature from -40°F to +40°F since the variation in the actual factors across this range is insignificant.

kW

Valve size	Evaporator temperature											
	10°C						0°C					
	Pressure drop across valve (kPa)						Pressure drop across valve (kPa)					
	750	1000	1100	1450	1700	2000	750	1000	1100	1450	1700	2000
1/4	0.50	0.57	0.60	0.69	0.75	0.81	0.49	0.57	0.60	0.69	0.74	0.81
1/2	0.97	1.12	1.17	1.34	1.46	1.58	0.96	1.11	1.16	1.33	1.44	1.56
1	3.40	3.92	4.11	4.72	5.11	5.55	3.37	3.89	4.08	4.68	5.07	5.50
3	7.18	8.29	8.69	9.98	10.80	11.72	7.11	8.22	8.62	9.89	10.71	11.62
5	10.69	12.34	12.95	14.86	16.09	17.46	10.60	12.24	12.84	14.74	15.96	17.31
6	13.21	15.25	16.00	18.37	19.89	21.57	13.10	15.12	15.86	18.21	19.72	21.39

Valve size	Evaporator temperature											
	-10°C						-20°C					
	Pressure drop across valve (kPa)						Pressure drop across valve (kPa)					
	750	1000	1100	1450	1700	2000	1000	1100	1450	1700	2000	2300
1/4	0.48	0.56	0.59	0.67	0.73	0.79	1.20	1.26	1.45	1.57	1.70	1.83
1/2	0.94	1.08	1.14	1.30	1.41	1.53	2.12	2.23	2.56	2.77	3.00	3.22
1	3.30	3.81	3.99	4.58	4.96	5.38	3.36	3.53	4.05	4.38	4.76	5.10
3	6.96	8.04	8.43	9.68	10.48	11.37	4.81	5.05	5.80	6.28	6.81	7.30
5	10.37	11.98	12.56	14.42	15.62	16.94	7.12	7.46	8.57	9.28	10.06	10.79
6	12.82	14.80	15.52	17.82	19.29	20.93	14.51	15.22	17.48	18.92	20.53	22.01

Valve size	Evaporator temperature											
	-30°C						-40°C					
	Pressure drop across valve (kPa)						Pressure drop across valve (kPa)					
	1000	1100	1450	1700	2000	2300	1000	1100	1450	1700	2000	2300
1/4	0.85	0.89	1.02	1.11	1.20	1.29	0.57	0.59	0.68	0.74	0.80	0.86
1/2	1.45	1.52	1.75	1.89	2.05	2.20	0.96	1.00	1.15	1.25	1.35	1.45
1	2.34	2.45	2.81	3.05	3.30	3.54	1.56	1.63	1.88	2.03	2.20	2.36
3	3.36	3.53	4.05	4.38	4.76	5.10	2.23	2.34	2.69	2.91	3.15	3.38
5	4.96	5.20	5.97	6.46	7.01	7.52	3.29	3.45	3.96	4.29	4.66	4.99
6	10.09	10.58	12.15	13.15	14.27	15.30	6.69	7.02	8.06	8.72	9.46	10.15

Expansion valve capacity at 100% duty cycle

Tons

Valve size	Evaporator temperature											
	50°F						40°F					
	Pressure drop across valve (psi)						Pressure drop across valve (psi)					
	60	80	100	125	150	175	60	80	100	125	150	175
1/4	0.11	0.13	0.15	0.16	0.18	0.19	0.11	0.13	0.14	0.16	0.17	0.19
1/2	0.22	0.26	0.29	0.32	0.36	0.38	0.22	0.26	0.29	0.32	0.35	0.38
1	0.79	0.92	1.03	1.15	1.26	1.36	0.78	0.90	1.01	1.13	1.24	1.33
3	1.67	1.93	2.15	2.41	2.64	2.85	1.64	1.90	2.12	2.37	2.60	2.80
5	2.48	2.86	3.20	3.58	3.92	4.23	2.44	2.82	3.15	3.52	3.86	4.16
6	3.06	3.53	3.95	4.41	4.83	5.22	3.01	3.47	3.88	4.34	4.75	5.13

Note: Standard capacity is rated at 100°F liquid inlet and 40°F evaporator temperature; with 100 psi pressure drop across the valve per AHRI 750.

kW

Valve size	Evaporator temperature											
	10°C						0°C					
	Pressure drop across valve (kPa)						Pressure drop across valve (kPa)					
	400	600	700	800	1000	1100	400	600	700	800	1000	1100
1/4	0.39	0.47	0.51	0.55	0.61	0.64	0.38	0.46	0.50	0.54	0.60	0.63
1/2	0.77	0.94	1.02	1.09	1.22	1.28	0.76	0.93	1.00	1.07	1.20	1.26
1	2.73	3.34	3.61	3.86	4.31	4.52	2.68	3.28	3.55	3.79	4.24	4.45
3	5.73	7.02	7.58	8.10	9.06	9.50	5.63	6.90	7.45	7.97	8.91	9.34
5	8.51	10.42	11.26	12.04	13.46	14.11	8.37	10.25	11.07	11.84	13.23	13.88
6	10.49	12.85	13.88	14.84	16.59	17.40	10.32	12.64	13.65	14.59	16.32	17.11

Valve size	Evaporator temperature											
	20°F						0°F					
	Pressure drop across valve (psi)						Pressure drop across valve (psi)					
	60	80	100	125	150	175	60	80	100	125	150	175
1/4	0.11	0.12	0.14	0.15	0.17	0.18	0.10	0.12	0.13	0.15	0.16	0.17
1/2	0.21	0.25	0.27	0.31	0.34	0.36	0.20	0.24	0.26	0.29	0.32	0.35
1	0.75	0.87	0.97	1.09	1.19	1.29	0.72	0.83	0.93	1.04	1.14	1.23
3	1.58	1.83	2.04	2.28	2.50	2.70	1.52	1.75	1.96	2.19	2.40	2.59
5	2.35	2.71	3.03	3.39	3.72	4.01	2.25	2.60	2.91	3.25	3.56	3.85
6	2.90	3.35	3.74	4.18	4.58	4.95	2.78	3.21	3.59	4.01	4.39	4.75

Valve size	Evaporator temperature											
	-10°C						-20°C					
	Pressure drop across valve (kPa)						Pressure drop across valve (kPa)					
	400	600	700	800	1000	1100	400	600	700	800	1000	1100
1/4	0.37	0.45	0.48	0.52	0.58	0.61	0.35	0.43	0.46	0.50	0.55	0.58
1/2	0.73	0.90	0.97	1.03	1.16	1.21	0.70	0.86	0.93	0.99	1.11	1.16
1	2.58	3.16	3.42	3.65	4.09	4.29	2.48	3.03	3.28	3.50	3.92	4.11
3	5.43	6.65	7.18	7.68	8.58	9.00	5.21	6.38	6.89	7.36	8.23	8.63
5	8.07	9.88	10.67	11.41	12.75	13.37	7.73	9.47	10.23	10.94	12.23	12.83
6	9.94	12.18	13.16	14.06	15.72	16.49	9.54	11.68	12.61	13.49	15.08	15.81

Valve size	Evaporator temperature											
	-20°F						-40°F					
	Pressure drop across valve (psi)						Pressure drop across valve (psi)					
	80	100	125	150	175	200	80	100	125	150	175	200
1/4	0.08	0.09	0.10	0.11	0.12	0.13	0.05	0.06	0.07	0.07	0.08	0.08
1/2	0.16	0.18	0.20	0.22	0.24	0.26	0.11	0.12	0.13	0.15	0.16	0.17
1	0.58	0.65	0.72	0.79	0.86	0.92	0.38	0.42	0.47	0.51	0.56	0.59
3	1.22	1.36	1.52	1.67	1.80	1.93	0.79	0.88	0.99	1.08	1.17	1.25
5	1.81	2.02	2.26	2.48	2.68	2.86	1.17	1.31	1.47	1.60	1.73	1.85
6	2.23	2.49	2.79	3.05	3.30	3.53	1.45	1.62	1.81	1.98	2.14	2.29

Valve size	Evaporator temperature											
	-30°C						-40°C					
	Pressure drop across valve (kPa)						Pressure drop across valve (kPa)					
	600	700	800	1000	1100	1200	600	700	800	1000	1100	1200
1/4	0.30	0.32	0.34	0.39	0.40	0.42	0.19	0.21	0.22	0.25	0.26	0.27
1/2	0.60	0.64	0.69	0.77	0.81	0.84	0.39	0.42	0.45	0.50	0.52	0.55
1	2.11	2.28	2.44	2.72	2.86	2.98	1.37	1.48	1.58	1.76	1.85	1.93
3	4.43	4.79	5.12	5.72	6.00	6.27	2.87	3.10	3.32	3.71	3.89	4.06
5	6.58	7.11	7.60	8.50	8.91	9.31	4.27	4.61	4.93	5.51	5.78	6.03
6	8.12	8.77	9.37	10.48	10.99	11.48	5.26	5.68	6.07	6.79	7.12	7.44

Note: All capacities shown are at 100% duty cycle (zero reserve capacity). Sizing is recommended for 50-80% duty cycle to accommodate load fluctuations. The refrigerant entering the valve must be in the liquid phase.

Refrigerant liquid temperature correction factors

Refrigerant liquid temperature °f														
0	10	20	30	40	50	60	70	80	90	100	110	120	130	140
1.78	1.71	1.63	1.56	1.48	1.40	1.32	1.24	1.16	1.08	1.00	0.92	0.83	0.74	0.65

Note: These factors include corrections for liquid refrigerant density and net refrigeration effect, and are based on an average evaporator temperature of 0°F. However, they may be used for any temperature from -40°F to +40°F since the variation in the actual factors across this range is insignificant.

Expansion valve capacity at 100% duty cycle

Tons

Valve size	Evaporator temperature											
	50°F						40°F					
	Pressure drop across valve (psi)						Pressure drop across valve (psi)					
	60	80	100	125	150	175	60	80	100	125	150	175
1/4	0.15	0.17	0.19	0.22	0.24	0.25	0.15	0.17	0.19	0.21	0.23	0.25
1/2	0.30	0.34	0.39	0.43	0.47	0.51	0.30	0.34	0.38	0.43	0.47	0.51
1	1.05	1.22	1.36	1.52	1.67	1.80	1.05	1.21	1.35	1.51	1.66	1.79
3	2.22	2.56	2.86	3.20	3.50	3.78	2.20	2.54	2.84	3.17	3.48	3.76
5	3.29	3.80	4.25	4.75	5.21	5.62	3.27	3.77	4.22	4.72	5.17	5.58
6	4.06	4.69	5.24	5.86	6.42	6.93	4.03	4.65	5.20	5.82	6.37	6.88

Note: Standard capacity is rated at 100°F liquid inlet and 40°F evaporator temperature; with 100 psi pressure drop across the valve per AHRI 750.

Valve size	Evaporator temperature											
	20°F						0°F					
	Pressure drop across valve (psi)						Pressure drop across valve (psi)					
	60	80	100	125	150	175	60	80	100	125	150	175
1/4	0.15	0.17	0.19	0.21	0.23	0.25	0.14	0.16	0.18	0.20	0.22	0.24
1/2	0.29	0.34	0.38	0.42	0.46	0.50	0.28	0.33	0.37	0.41	0.45	0.49
1	1.03	1.19	1.33	1.48	1.62	1.76	1.00	1.16	1.30	1.45	1.59	1.72
3	2.16	2.49	2.79	3.12	3.41	3.69	2.11	2.44	2.72	3.05	3.34	3.60
5	3.21	3.70	4.14	4.63	5.07	5.48	3.13	3.62	4.05	4.52	4.96	5.35
6	3.95	4.57	5.11	5.71	6.25	6.75	3.87	4.46	4.99	5.58	6.11	6.60

Valve size	Evaporator temperature											
	-20°F						-40°F					
	Pressure drop across valve (psi)						Pressure drop across valve (psi)					
	80	100	125	150	175	200	80	100	125	150	175	200
1/4	0.15	0.17	0.19	0.21	0.23	0.24	0.10	0.12	0.13	0.14	0.15	0.16
1/2	0.31	0.35	0.39	0.42	0.46	0.49	0.21	0.23	0.26	0.28	0.31	0.33
1	1.09	1.22	1.37	1.50	1.62	1.73	0.74	0.82	0.92	1.01	1.09	1.16
3	2.30	2.57	2.87	3.14	3.40	3.63	1.55	1.73	1.93	2.12	2.29	2.44
5	3.41	3.81	4.26	4.67	5.05	5.39	2.30	2.57	2.87	3.14	3.40	3.63
6	4.21	4.70	5.26	5.76	6.22	6.65	2.83	3.17	3.54	3.88	4.19	4.48

Note: All capacities shown are at 100% duty cycle (zero reserve capacity). Sizing is recommended for 50-80% duty cycle to accommodate load fluctuations. The refrigerant entering the valve must be in the liquid phase.

Refrigerant liquid temperature correction factors

Refrigerant liquid temperature °f														
0	10	20	30	40	50	60	70	80	90	100	110	120	130	140
1.67	1.60	1.54	1.47	1.41	1.34	1.28	1.21	1.14	1.07	1.00	0.93	0.85	0.78	0.69

Note: These factors include corrections for liquid refrigerant density and net refrigeration effect, and are based on an average evaporator temperature of 0°F. However, they may be used for any temperature from -40°F to +40°F since the variation in the actual factors across this range is insignificant.

kW

Valve size	Evaporator temperature											
	10°C						0°C					
	Pressure drop across valve (kPa)						Pressure drop across valve (kPa)					
	400	600	700	800	1000	1100	400	600	700	800	1000	1100
1/4	0.51	0.63	0.68	0.72	0.81	0.85	0.51	0.62	0.67	0.72	0.80	0.84
1/2	1.02	1.25	1.35	1.45	1.62	1.70	1.02	1.24	1.34	1.44	1.61	1.69
1	3.62	4.43	4.79	5.12	5.72	6.00	3.59	4.40	4.75	5.08	5.68	5.96
3	7.61	9.32	10.06	10.76	12.03	12.61	7.55	9.25	9.99	10.68	11.94	12.52
5	11.30	13.84	14.95	15.98	17.87	18.74	11.22	13.74	14.84	15.86	17.73	18.60
6	13.93	17.06	18.43	19.70	22.03	23.10	13.83	16.94	18.29	19.56	21.87	22.93

Valve size	Evaporator temperature											
	-10°C						-20°C					
	Pressure drop across valve (kPa)						Pressure drop across valve (kPa)					
	400	600	700	800	1000	1100	400	600	700	800	1000	1100
1/4	0.50	0.61	0.66	0.71	0.79	0.83	0.49	0.60	0.64	0.69	0.77	0.81
1/2	1.00	1.22	1.32	1.41	1.58	1.65	0.97	1.19	1.29	1.38	1.54	1.62
1	3.53	4.32	4.67	4.99	5.58	5.85	3.45	4.22	4.56	4.87	5.45	5.72
3	7.41	9.08	9.80	10.48	11.72	12.29	7.24	8.87	9.58	10.24	11.45	12.01
5	11.01	13.48	14.56	15.57	17.41	18.26	10.76	13.18	14.23	15.22	17.01	17.84
6	13.57	16.62	17.96	19.20	21.46	22.51	13.27	16.25	17.55	18.76	20.97	22.00

Valve size	Evaporator temperature											
	-30°C						-40°C					
	Pressure drop across valve (kPa)						Pressure drop across valve (kPa)					
	600	700	800	1000	1100	1200	600	700	800	1000	1100	1200
1/4	0.56	0.61	0.65	0.73	0.76	0.80	0.38	0.41	0.44	0.49	0.51	0.54
1/2	1.13	1.22	1.30	1.45	1.52	1.59	0.76	0.82	0.87	0.98	1.03	1.07
1	3.98	4.30	4.59	5.14	5.39	5.63	2.68	2.89	3.09	3.46	3.63	3.79
3	8.36	9.03	9.65	10.79	11.32	11.82	5.63	6.08	6.50	7.26	7.62	7.96
5	12.42	13.41	14.34	16.03	16.81	17.56	8.36	9.03	9.65	10.79	11.32	11.82
6	15.31	16.54	17.68	19.77	20.73	21.65	10.31	11.13	11.90	13.30	13.95	14.57

Expansion valve capacity at 100% duty cycle

Tons

Valve size	Evaporator temperature											
	50°F						40°F					
	Pressure drop across valve (psi)						Pressure drop across valve (psi)					
	60	80	100	125	150	175	60	80	100	125	150	175
1/4	0.09	0.11	0.12	0.13	0.15	0.16	0.09	0.10	0.12	0.13	0.14	0.16
1/2	0.19	0.21	0.24	0.27	0.29	0.32	0.18	0.21	0.23	0.26	0.29	0.31
1	0.66	0.76	0.85	0.95	1.04	1.12	0.64	0.74	0.83	0.93	1.02	1.10
3	1.38	1.59	1.78	1.99	2.18	2.36	1.35	1.56	1.74	1.95	2.13	2.30
5	2.05	2.37	2.65	2.96	3.24	3.50	2.00	2.31	2.59	2.89	3.17	3.42
6	2.53	2.92	3.26	3.65	3.99	4.31	2.47	2.85	3.19	3.57	3.91	4.22

Note: Standard capacity is rated at 100°F liquid inlet and 40°F evaporator temperature; with 100 psi pressure drop across the valve per AHRI 750.

kW

Valve size	Evaporator temperature											
	10°C						0°C					
	Pressure drop across valve (kPa)						Pressure drop across valve (kPa)					
	400	600	700	800	1000	1100	400	600	700	800	1000	1100
1/4	0.32	0.39	0.42	0.45	0.50	0.53	0.31	0.38	0.41	0.44	0.49	0.52
1/2	0.64	0.78	0.84	0.90	1.01	1.06	0.62	0.76	0.82	0.88	0.99	1.03
1	2.25	2.76	2.98	3.19	3.56	3.74	2.20	2.70	2.92	3.12	3.49	3.66
3	4.73	5.80	6.26	6.69	7.48	7.85	4.63	5.67	6.13	6.55	7.32	7.68
5	7.03	8.61	9.30	9.94	11.12	11.66	6.88	8.43	9.10	9.73	10.88	11.41
6	8.67	10.62	11.47	12.26	13.71	14.38	8.48	10.39	11.22	12.00	13.41	14.07

Valve size	Evaporator temperature											
	20°F						0°F					
	Pressure drop across valve (psi)						Pressure drop across valve (psi)					
	60	80	100	125	150	175	60	80	100	125	150	175
1/4	0.09	0.10	0.11	0.13	0.14	0.15	0.07	0.08	0.09	0.10	0.11	0.12
1/2	0.17	0.20	0.22	0.25	0.27	0.30	0.14	0.16	0.18	0.20	0.22	0.24
1	0.61	0.71	0.79	0.88	0.97	1.05	0.50	0.57	0.64	0.72	0.79	0.85
3	1.29	1.49	1.66	1.86	2.03	2.20	1.04	1.21	1.35	1.51	1.65	1.78
5	1.91	2.21	2.47	2.76	3.02	3.27	1.55	1.79	2.00	2.24	2.45	2.65
6	2.36	2.72	3.04	3.40	3.73	4.03	1.91	2.21	2.47	2.76	3.03	3.27

Valve size	Evaporator temperature											
	-10°C						-20°C					
	Pressure drop across valve (kPa)						Pressure drop across valve (kPa)					
	400	600	700	800	1000	1100	400	600	700	800	1000	1100
1/4	0.30	0.36	0.39	0.42	0.47	0.49	0.24	0.30	0.32	0.34	0.38	0.40
1/2	0.59	0.73	0.79	0.84	0.94	0.99	0.48	0.59	0.64	0.68	0.76	0.80
1	2.10	2.57	2.78	2.97	3.32	3.49	1.71	2.09	2.26	2.41	2.70	2.83
3	4.42	5.41	5.84	6.25	6.98	7.32	3.59	4.39	4.74	5.07	5.67	5.95
5	6.56	8.04	8.68	9.28	10.38	10.88	5.33	6.53	7.05	7.53	8.42	8.83
6	8.09	9.91	10.70	11.44	12.79	13.42	6.57	8.05	8.69	9.29	10.39	10.89

Valve size	Evaporator temperature											
	-20°F						-40°F					
	Pressure drop across valve (psi)						Pressure drop across valve (psi)					
	80	100	125	150	175	200	80	100	125	150	175	200
1/4	0.05	0.06	0.07	0.07	0.08	0.09	0.03	0.04	0.04	0.05	0.05	0.05
1/2	0.11	0.12	0.14	0.15	0.16	0.17	0.07	0.08	0.09	0.09	0.10	0.11
1	0.38	0.43	0.48	0.52	0.57	0.61	0.24	0.27	0.30	0.33	0.36	0.38
3	0.80	0.90	1.01	1.10	1.19	1.27	0.51	0.57	0.64	0.70	0.76	0.81
5	1.19	1.34	1.49	1.64	1.77	1.89	0.76	0.85	0.95	1.04	1.12	1.20
6	1.47	1.65	1.84	2.02	2.18	2.33	0.94	1.05	1.17	1.28	1.39	1.48

Valve size	Evaporator temperature											
	-30°C						-40°C					
	Pressure drop across valve (kPa)						Pressure drop across valve (kPa)					
	600	700	800	1000	1100	1200	600	700	800	1000	1100	1200
1/4	0.20	0.21	0.23	0.25	0.27	0.28	0.13	0.14	0.14	0.16	0.17	0.18
1/2	0.39	0.43	0.46	0.51	0.53	0.56	0.25	0.27	0.29	0.32	0.34	0.35
1	1.39	1.50	1.61	1.80	1.89	1.97	0.89	0.96	1.02	1.14	1.20	1.25
3	2.93	3.16	3.38	3.78	3.96	4.14	1.86	2.01	2.15	2.40	2.52	2.63
5	4.35	4.70	5.02	5.61	5.89	6.15	2.76	2.99	3.19	3.57	3.74	3.91
6	5.36	5.79	6.19	6.92	7.26	7.58	3.41	3.68	3.94	4.40	4.62	4.82

Note: All capacities shown are at 100% duty cycle (zero reserve capacity). Sizing is recommended for 50-80% duty cycle to accommodate load fluctuations. The refrigerant entering the valve must be in the liquid phase.

Refrigerant liquid temperature correction factors

Refrigerant liquid temperature °F														
0	10	20	30	40	50	60	70	80	90	100	110	120	130	140
1.83	1.75	1.67	1.59	1.51	1.42	1.34	1.26	1.17	1.09	1.00	0.91	0.82	0.73	0.64

Note: These factors include corrections for liquid refrigerant density and net refrigeration effect, and are based on an average evaporator temperature of 0°F. However, they may be used for any temperature from -40°F to +40°F since the variation in the actual factors across this range is insignificant.

Expansion valve capacity at 100% duty cycle

Tons

Valve size	Evaporator temperature											
	50°F						40°F					
	Pressure drop across valve (psi)						Pressure drop across valve (psi)					
	60	80	100	125	150	175	60	80	100	125	150	175
1/4	0.11	0.12	0.14	0.16	0.17	0.18	0.11	0.12	0.14	0.15	0.17	0.18
1/2	0.22	0.25	0.28	0.31	0.34	0.37	0.21	0.24	0.27	0.30	0.33	0.36
1	0.76	0.88	0.98	1.10	1.20	1.30	0.75	0.86	0.96	1.08	1.18	1.27
3	1.60	1.85	2.07	2.31	2.53	2.73	1.57	1.81	2.02	2.26	2.48	2.68
5	2.38	2.74	3.07	3.43	3.76	4.06	2.33	2.69	3.00	3.36	3.68	3.97
6	2.93	3.38	3.78	4.23	4.63	5.01	2.87	3.31	3.70	4.14	4.54	4.90

Note: Standard capacity is rated at 100°F liquid inlet and 40°F evaporator temperature; with 100 psi pressure drop across the valve per AHRI 750.

Valve size	Evaporator temperature											
	20°F						0°F					
	Pressure drop across valve (psi)						Pressure drop across valve (psi)					
	60	80	100	125	150	175	60	80	100	125	150	175
1/4	0.10	0.12	0.13	0.15	0.16	0.17	0.09	0.10	0.11	0.13	0.14	0.15
1/2	0.20	0.23	0.26	0.29	0.32	0.34	0.17	0.20	0.23	0.25	0.28	0.30
1	0.71	0.82	0.92	1.03	1.13	1.22	0.62	0.71	0.80	0.89	0.98	1.05
3	1.50	1.73	1.93	2.16	2.37	2.56	1.30	1.50	1.68	1.87	2.05	2.22
5	2.22	2.57	2.87	3.21	3.51	3.80	1.93	2.23	2.49	2.78	3.05	3.29
6	2.74	3.16	3.54	3.96	4.33	4.68	2.38	2.74	3.07	3.43	3.76	4.06

Valve size	Evaporator temperature											
	-20°F						-40°F					
	Pressure drop across valve (psi)						Pressure drop across valve (psi)					
	80	100	125	150	175	200	80	100	125	150	175	200
1/4	0.07	0.08	0.08	0.09	0.10	0.11	0.04	0.05	0.05	0.06	0.06	0.07
1/2	0.13	0.15	0.17	0.18	0.20	0.21	0.09	0.10	0.11	0.12	0.13	0.14
1	0.48	0.53	0.60	0.65	0.70	0.75	0.30	0.34	0.38	0.42	0.45	0.48
3	1.00	1.12	1.25	1.37	1.48	1.58	0.64	0.71	0.80	0.87	0.94	1.01
5	1.49	1.66	1.86	2.04	2.20	2.35	0.95	1.06	1.18	1.30	1.40	1.50
6	1.83	2.05	2.29	2.51	2.71	2.90	1.17	1.31	1.46	1.60	1.73	1.85

Note: All capacities shown are at 100% duty cycle (zero reserve capacity). Sizing is recommended for 50-80% duty cycle to accommodate load fluctuations. The refrigerant entering the valve must be in the liquid phase.

Refrigerant liquid temperature correction factors

Refrigerant liquid temperature °f														
0	10	20	30	40	50	60	70	80	90	100	110	120	130	140
1.83	1.75	1.67	1.59	1.51	1.42	1.34	1.26	1.17	1.09	1.00	0.91	0.82	0.73	0.64

Note: These factors include corrections for liquid refrigerant density and net refrigeration effect, and are based on an average evaporator temperature of 0°F. However, they may be used for any temperature from -40°F to +40°F since the variation in the actual factors across this range is insignificant.

kW

Valve size	Evaporator temperature											
	10°C						0°C					
	Pressure drop across valve (kPa)						Pressure drop across valve (kPa)					
	400	600	700	800	1000	1100	400	600	700	800	1000	1100
1/4	0.37	0.45	0.49	0.52	0.58	0.61	0.36	0.44	0.48	0.51	0.57	0.60
1/2	0.74	0.91	0.98	1.05	1.17	1.23	0.72	0.89	0.96	1.02	1.14	1.20
1	2.61	3.20	3.46	3.70	4.13	4.33	2.56	3.13	3.39	3.62	4.05	4.24
3	5.49	6.73	7.26	7.77	8.68	9.11	5.38	6.58	7.11	7.60	8.50	8.92
5	8.16	9.99	10.79	11.54	12.90	13.53	7.99	9.78	10.57	11.30	12.63	13.25
6	10.06	12.32	13.31	14.22	15.90	16.68	9.85	12.06	13.03	13.93	15.57	16.33

Valve size	Evaporator temperature											
	-10°C						-20°C					
	Pressure drop across valve (kPa)						Pressure drop across valve (kPa)					
	400	600	700	800	1000	1100	400	600	700	800	1000	1100
1/4	0.35	0.42	0.46	0.49	0.55	0.57	0.30	0.37	0.40	0.42	0.47	0.50
1/2	0.69	0.85	0.91	0.98	1.09	1.15	0.60	0.73	0.79	0.85	0.95	0.99
1	2.44	2.99	3.23	3.46	3.86	4.05	2.12	2.60	2.80	3.00	3.35	3.52
3	5.14	6.29	6.79	7.26	8.12	8.52	4.45	5.46	5.89	6.30	7.04	7.39
5	7.63	9.34	10.09	10.79	12.06	12.65	6.62	8.10	8.75	9.36	10.46	10.97
6	9.41	11.52	12.44	13.30	14.87	15.60	8.16	9.99	10.79	11.54	12.90	13.53

Valve size	Evaporator temperature											
	-30°C						-40°C					
	Pressure drop across valve (kPa)						Pressure drop across valve (kPa)					
	600	700	800	1000	1100	1200	600	700	800	1000	1100	1200
1/4	0.25	0.26	0.28	0.32	0.33	0.35	0.16	0.17	0.18	0.20	0.21	0.22
1/2	0.49	0.53	0.57	0.63	0.66	0.69	0.31	0.34	0.36	0.40	0.42	0.44
1	1.73	1.87	2.00	2.24	2.35	2.45	1.11	1.19	1.28	1.43	1.50	1.56
3	3.64	3.94	4.21	4.70	4.93	5.15	2.32	2.51	2.68	3.00	3.14	3.28
5	5.41	5.85	6.25	6.99	7.33	7.66	3.45	3.73	3.98	4.45	4.67	4.88
6	6.68	7.21	7.71	8.62	9.04	9.44	4.25	4.59	4.91	5.49	5.76	6.01

Expansion valve capacity at 100% duty cycle

Tons

Valve size	Evaporator temperature											
	50°F						40°F					
	Pressure drop across valve (psi)						Pressure drop across valve (psi)					
	60	80	100	125	150	175	60	80	100	125	150	175
1/4	0.09	0.10	0.11	0.13	0.14	0.15	0.09	0.10	0.11	0.12	0.14	0.15
1/2	0.18	0.20	0.23	0.25	0.28	0.30	0.17	0.20	0.22	0.25	0.27	0.29
1	0.62	0.72	0.80	0.90	0.98	1.06	0.61	0.70	0.78	0.88	0.96	1.04
3	1.30	1.50	1.68	1.88	2.06	2.23	1.28	1.47	1.65	1.84	2.02	2.18
5	1.94	2.24	2.50	2.79	3.06	3.31	1.90	2.19	2.45	2.74	3.00	3.24
6	2.39	2.76	3.08	3.45	3.77	4.08	2.34	2.70	3.02	3.37	3.70	3.99

Note: Standard capacity is rated at 100°F liquid inlet and 40°F evaporator temperature; with 100 psi pressure drop across the valve per AHRI 750.

Valve size	Evaporator temperature											
	20°F						0°F					
	Pressure drop across valve (psi)						Pressure drop across valve (psi)					
	60	80	100	125	150	175	60	80	100	125	150	175
1/4	0.08	0.09	0.11	0.12	0.13	0.14	0.06	0.07	0.08	0.09	0.10	0.10
1/2	0.16	0.19	0.21	0.24	0.26	0.28	0.12	0.14	0.16	0.18	0.19	0.21
1	0.58	0.67	0.75	0.84	0.92	0.99	0.43	0.50	0.56	0.63	0.68	0.74
3	1.22	1.41	1.58	1.76	1.93	2.08	0.91	1.05	1.17	1.31	1.44	1.55
5	1.81	2.09	2.34	2.62	2.87	3.10	1.35	1.56	1.75	1.95	2.14	2.31
6	2.24	2.58	2.89	3.23	3.53	3.82	1.67	1.92	2.15	2.41	2.64	2.85

Valve size	Evaporator temperature											
	-20°F						-40°F					
	Pressure drop across valve (psi)						Pressure drop across valve (psi)					
	80	100	125	150	175	200	80	100	125	150	175	200
1/4	0.05	0.05	0.06	0.06	0.07	0.07	0.03	0.03	0.04	0.04	0.04	0.05
1/2	0.09	0.11	0.12	0.13	0.14	0.15	0.06	0.07	0.07	0.08	0.09	0.09
1	0.33	0.37	0.42	0.46	0.49	0.53	0.21	0.24	0.26	0.29	0.31	0.33
3	0.70	0.78	0.88	0.96	1.04	1.11	0.45	0.50	0.56	0.61	0.66	0.70
5	1.04	1.16	1.30	1.42	1.54	1.64	0.66	0.74	0.83	0.91	0.98	1.05
6	1.28	1.43	1.60	1.76	1.90	2.03	0.82	0.91	1.02	1.12	1.21	1.29

Note: All capacities shown are at 100% duty cycle (zero reserve capacity). Sizing is recommended for 50-80% duty cycle to accommodate load fluctuations. The refrigerant entering the valve must be in the liquid phase.

Refrigerant liquid temperature correction factors

Refrigerant liquid temperature °f														
0	10	20	30	40	50	60	70	80	90	100	110	120	130	140
1.77	1.70	1.62	1.55	1.47	1.39	1.31	1.24	1.16	1.08	1.00	0.92	0.84	0.75	0.67

Note: These factors include corrections for liquid refrigerant density and net refrigeration effect, and are based on an average evaporator temperature of 0°F. However, they may be used for any temperature from -40°F to +40°F since the variation in the actual factors across this range is insignificant.

kW

Valve size	Evaporator temperature											
	10°C						0°C					
	Pressure drop across valve (kPa)						Pressure drop across valve (kPa)					
	400	600	700	800	1000	1100	400	600	700	800	1000	1100
1/4	0.30	0.37	0.40	0.43	0.48	0.50	0.29	0.36	0.39	0.42	0.47	0.49
1/2	0.60	0.74	0.80	0.85	0.95	1.00	0.59	0.72	0.78	0.83	0.93	0.98
1	2.13	2.61	2.82	3.01	3.37	3.53	2.09	2.55	2.76	2.95	3.30	3.46
3	4.47	5.48	5.92	6.32	7.07	7.42	4.38	5.37	5.79	6.20	6.93	7.26
5	6.64	8.14	8.79	9.40	10.50	11.02	6.51	7.97	8.61	9.20	10.29	10.79
6	8.19	10.03	10.84	11.59	12.95	13.58	8.02	9.83	10.61	11.35	12.69	13.31

Valve size	Evaporator temperature											
	-10°C						-20°C					
	Pressure drop across valve (kPa)						Pressure drop across valve (kPa)					
	400	600	700	800	1000	1100	400	600	700	800	1000	1100
1/4	0.28	0.35	0.37	0.40	0.45	0.47	0.21	0.26	0.28	0.30	0.33	0.35
1/2	0.56	0.69	0.75	0.80	0.89	0.93	0.42	0.51	0.56	0.59	0.66	0.70
1	1.99	2.44	2.64	2.82	3.15	3.31	1.49	1.82	1.97	2.10	2.35	2.46
3	4.19	5.13	5.54	5.92	6.62	6.94	3.12	3.82	4.13	4.42	4.94	5.18
5	6.22	7.62	8.23	8.80	9.84	10.32	4.64	5.68	6.14	6.56	7.34	7.69
6	7.67	9.39	10.15	10.85	12.13	12.72	5.72	7.01	7.57	8.09	9.04	9.49

Valve size	Evaporator temperature											
	-30°C						-40°C					
	Pressure drop across valve (kPa)						Pressure drop across valve (kPa)					
	600	700	800	1000	1100	1200	600	700	800	1000	1100	1200
1/4	0.17	0.19	0.20	0.22	0.23	0.24	0.11	0.12	0.13	0.14	0.15	0.15
1/2	0.34	0.37	0.40	0.44	0.46	0.49	0.22	0.24	0.25	0.28	0.30	0.31
1	1.21	1.31	1.40	1.57	1.64	1.72	0.77	0.83	0.89	1.00	1.04	1.09
3	2.55	2.75	2.94	3.29	3.45	3.60	1.62	1.75	1.87	2.09	2.19	2.29
5	3.79	4.09	4.37	4.89	5.13	5.35	2.41	2.60	2.78	3.11	3.26	3.40
6	4.67	5.04	5.39	6.03	6.32	6.60	2.97	3.21	3.43	3.83	4.02	4.20

Expansion valve capacity at 100% duty cycle

Tons

Valve size	Evaporator temperature											
	50°F						40°F					
	Pressure drop across valve (psi)						Pressure drop across valve (psi)					
	60	80	100	125	150	175	60	80	100	125	150	175
1/4	0.09	0.10	0.11	0.13	0.14	0.15	0.09	0.10	0.11	0.12	0.13	0.15
1/2	0.17	0.19	0.22	0.24	0.26	0.29	0.16	0.19	0.21	0.23	0.26	0.28
1	0.60	0.70	0.78	0.87	0.96	1.03	0.59	0.68	0.76	0.85	0.93	1.01
3	1.26	1.46	1.63	1.82	2.00	2.16	1.23	1.42	1.59	1.78	1.95	2.10
5	1.88	2.18	2.43	2.72	2.98	3.22	1.84	2.12	2.37	2.65	2.90	3.14
6	2.33	2.69	3.01	3.36	3.68	3.98	2.27	2.62	2.93	3.28	3.59	3.88

Note: Standard capacity is rated at 100°F liquid inlet and 40°F evaporator temperature; with 100 psi pressure drop across the valve per AHRI 750.

Valve size	Evaporator temperature											
	20°F						0°F					
	Pressure drop across valve (psi)						Pressure drop across valve (psi)					
	60	80	100	125	150	175	60	80	100	125	150	175
1/4	0.07	0.08	0.09	0.10	0.11	0.12	0.05	0.05	0.06	0.07	0.07	0.08
1/2	0.13	0.15	0.17	0.19	0.21	0.23	0.09	0.10	0.12	0.13	0.14	0.15
1	0.48	0.55	0.62	0.69	0.76	0.82	0.33	0.38	0.42	0.47	0.52	0.56
3	1.00	1.16	1.29	1.45	1.59	1.71	0.68	0.79	0.88	0.99	1.08	1.17
5	1.49	1.73	1.93	2.16	2.36	2.55	1.02	1.17	1.31	1.47	1.61	1.74
6	1.85	2.13	2.38	2.67	2.92	3.16	1.26	1.45	1.62	1.82	1.99	2.15

Valve size	Evaporator temperature											
	-20°F						-40°F					
	Pressure drop across valve (psi)						Pressure drop across valve (psi)					
	80	100	125	150	175	200	80	100	125	150	175	200
1/4	0.04	0.04	0.04	0.05	0.05	0.06	0.02	0.02	0.03	0.03	0.03	0.03
1/2	0.07	0.08	0.08	0.09	0.10	0.11	0.04	0.05	0.05	0.06	0.06	0.07
1	0.25	0.27	0.31	0.34	0.36	0.39	0.15	0.17	0.19	0.21	0.23	0.24
3	0.51	0.57	0.64	0.70	0.76	0.81	0.32	0.36	0.40	0.44	0.47	0.50
5	0.77	0.86	0.96	1.05	1.13	1.21	0.47	0.53	0.59	0.65	0.70	0.75
6	0.95	1.06	1.18	1.30	1.40	1.50	0.59	0.66	0.73	0.80	0.87	0.93

Note: All capacities shown are at 100% duty cycle (zero reserve capacity). Sizing is recommended for 50-80% duty cycle to accommodate load fluctuations. The refrigerant entering the valve must be in the liquid phase.

Refrigerant liquid temperature correction factors

Refrigerant liquid temperature °f														
0	10	20	30	40	50	60	70	80	90	100	110	120	130	140
1.81	1.73	1.65	1.57	1.49	1.41	1.33	1.25	1.17	1.08	1.00	0.92	0.83	0.75	0.66

Note: These factors include corrections for liquid refrigerant density and net refrigeration effect, and are based on an average evaporator temperature of 0°F. However, they may be used for any temperature from -40°F to +40°F since the variation in the actual factors across this range is insignificant.

kW

Valve size	Evaporator temperature											
	10°C						0°C					
	Pressure drop across valve (kPa)						Pressure drop across valve (kPa)					
	400	600	700	800	1000	1100	400	600	700	800	1000	1100
1/4	0.30	0.37	0.40	0.42	0.47	0.50	0.29	0.36	0.39	0.41	0.46	0.48
1/2	0.57	0.70	0.76	0.81	0.91	0.95	0.56	0.68	0.74	0.79	0.88	0.93
1	2.07	2.54	2.74	2.93	3.28	3.44	2.02	2.47	2.67	2.86	3.19	3.35
3	4.34	5.31	5.74	6.14	6.86	7.19	4.23	5.18	5.59	5.98	6.68	7.01
5	6.47	7.92	8.55	9.15	10.22	10.72	6.30	7.72	8.33	8.91	9.96	10.45
6	7.99	9.79	10.58	11.31	12.64	13.26	7.79	9.54	10.30	11.02	12.32	12.92

Valve size	Evaporator temperature											
	-10°C						-20°C					
	Pressure drop across valve (kPa)						Pressure drop across valve (kPa)					
	400	600	700	800	1000	1100	400	600	700	800	1000	1100
1/4	0.24	0.29	0.31	0.34	0.38	0.39	0.16	0.20	0.21	0.23	0.26	0.27
1/2	0.45	0.56	0.60	0.64	0.72	0.75	0.31	0.38	0.41	0.44	0.49	0.51
1	1.64	2.01	2.18	2.33	2.60	2.73	1.12	1.37	1.48	1.58	1.77	1.86
3	3.44	4.21	4.55	4.87	5.44	5.71	2.34	2.87	3.10	3.31	3.70	3.88
5	5.13	6.28	6.78	7.25	8.11	8.50	3.49	4.28	4.62	4.94	5.52	5.79
6	6.34	7.77	8.39	8.97	10.03	10.51	4.32	5.29	5.71	6.10	6.82	7.16

Valve size	Evaporator temperature											
	-30°C						-40°C					
	Pressure drop across valve (kPa)						Pressure drop across valve (kPa)					
	600	700	800	1000	1100	1200	600	700	800	1000	1100	1200
1/4	0.13	0.14	0.15	0.17	0.18	0.18	0.08	0.09	0.09	0.10	0.11	0.11
1/2	0.25	0.27	0.29	0.32	0.33	0.35	0.15	0.17	0.18	0.20	0.21	0.22
1	0.89	0.97	1.03	1.15	1.21	1.26	0.55	0.60	0.64	0.72	0.75	0.78
3	1.87	2.02	2.16	2.41	2.53	2.65	1.16	1.25	1.34	1.50	1.57	1.64
5	2.79	3.01	3.22	3.60	3.77	3.94	1.73	1.87	1.99	2.23	2.34	2.44
6	3.45	3.72	3.98	4.45	4.67	4.87	2.14	2.31	2.47	2.76	2.89	3.02

Expansion valve capacity at 100% duty cycle

Tons

Entering liquid temp., °F	Evaporator temperature (°F)									
	-40	-30	-20	-10	0	10	20	30	40	
60	0.32	0.31	0.31	0.29	0.28	0.26	0.24	0.21	0.17	1/4
	0.62	0.60	0.59	0.56	0.53	0.50	0.45	0.40	0.32	1/2
	2.20	2.14	2.09	2.01	1.90	1.76	1.61	1.41	1.16	1
	4.63	4.52	4.40	4.23	4.00	3.72	3.38	2.98	2.44	3
	6.90	6.73	6.56	6.30	5.96	5.54	5.04	4.43	3.63	5
	8.51	8.30	8.09	7.77	7.35	6.83	6.21	5.47	4.48	6
50	0.33	0.32	0.31	0.29	0.27	0.25	0.22	0.18	0.13	1/4
	0.63	0.61	0.59	0.56	0.52	0.48	0.42	0.35	0.27	1/2
	2.24	2.18	2.10	2.00	1.87	1.71	1.50	1.25	0.96	1
	4.72	4.59	4.42	4.21	3.94	3.61	3.17	2.63	1.99	3
	7.03	6.83	6.58	6.28	5.86	5.38	4.72	3.91	2.95	5
	8.68	8.43	8.12	7.74	7.23	6.63	5.82	4.82	3.63	6
40	0.33	0.32	0.30	0.28	0.26	0.23	0.19	0.14	—	1/4
	0.63	0.61	0.58	0.54	0.50	0.44	0.37	0.29	—	1/2
	2.24	2.16	2.06	1.93	1.78	1.57	1.31	1.00	—	1
	4.72	4.55	4.34	4.07	3.76	3.32	2.76	2.08	—	3
	7.03	6.77	6.47	6.07	5.60	4.94	4.11	3.11	—	5
	8.68	8.35	7.98	7.49	6.91	6.09	5.07	3.86	—	6
30	0.32	0.31	0.29	0.27	0.24	0.20	0.15	—	—	1/4
	0.61	0.59	0.55	0.51	0.45	0.38	0.27	—	—	1/2
	2.19	2.09	1.97	1.81	1.62	1.34	1.00	—	—	1
	4.61	4.41	4.15	3.81	3.40	2.83	2.10	—	—	3
	6.87	6.57	6.18	5.68	5.07	4.22	3.13	—	—	5
	8.47	8.10	7.62	7.01	6.25	5.21	3.87	—	—	6
20	0.31	0.29	0.27	0.24	0.20	0.15	—	—	—	1/4
	0.59	0.56	0.51	0.46	0.39	0.31	—	—	—	1/2
	2.10	1.99	1.83	1.63	1.37	1.05	—	—	—	1
	4.43	4.19	3.86	3.44	2.89	2.21	—	—	—	3
	6.59	6.25	5.75	5.13	4.31	3.30	—	—	—	5
	8.13	7.71	7.10	6.32	5.32	4.07	—	—	—	6
10	0.29	0.27	0.24	0.20	0.15	—	—	—	—	1/4
	0.56	0.51	0.46	0.39	0.30	—	—	—	—	1/2
	1.98	1.83	1.64	1.38	1.05	—	—	—	—	1
	4.17	3.85	3.45	2.90	2.20	—	—	—	—	3
	6.21	5.74	5.14	4.32	3.27	—	—	—	—	5
	7.66	7.08	6.35	5.33	4.03	—	—	—	—	6
0	0.26	0.24	0.20	0.15	—	—	—	—	—	1/4
	0.51	0.45	0.38	0.29	—	—	—	—	—	1/2
	1.81	1.62	1.37	1.06	—	—	—	—	—	1
	3.81	3.41	2.89	2.24	—	—	—	—	—	3
	5.67	5.08	4.30	3.33	—	—	—	—	—	5
	7.00	6.27	5.30	4.10	—	—	—	—	—	6

kW

Entering liquid temp., °C	Evaporator temperature (°C)									
	-40	-34	-29	-23	-18	-12	-7	-1	4	
15	1.13	1.10	1.08	1.03	0.98	0.91	0.83	0.73	0.60	1/4
	2.17	2.12	2.06	1.98	1.88	1.74	1.59	1.40	1.14	1/2
	7.73	7.54	7.35	7.06	6.68	6.20	5.65	4.97	4.07	1
	16.28	15.88	15.48	14.87	14.07	13.07	11.90	10.47	8.57	3
	24.25	23.66	23.07	22.15	20.96	19.47	17.72	15.59	12.77	5
	29.92	29.18	28.45	27.32	25.85	24.02	21.86	19.23	15.75	6
10	1.15	1.12	1.08	1.03	0.96	0.88	0.77	0.64	0.46	1/4
	2.21	2.15	2.07	1.98	1.85	1.69	1.49	1.23	0.95	1/2
	7.88	7.66	7.38	7.03	6.57	6.03	5.29	4.38	3.36	1
	16.61	16.14	15.54	14.82	13.85	12.70	11.14	9.23	6.98	3
	24.74	24.04	23.15	22.08	20.62	18.91	16.60	13.75	10.38	5
	30.51	29.65	28.55	27.23	25.44	23.33	20.47	16.97	12.78	6
4	1.15	1.11	1.06	1.00	0.92	0.81	0.68	0.49	—	1/4
	2.21	2.13	2.04	1.91	1.76	1.55	1.29	1.02	—	1/2
	7.88	7.59	7.25	6.80	6.27	5.53	4.61	3.52	—	1
	16.61	15.99	15.28	14.33	13.22	11.66	9.71	7.32	—	3
	24.74	23.82	22.76	21.34	19.69	17.37	14.46	10.95	—	5
	30.51	29.38	28.07	26.33	24.29	21.43	17.84	13.59	—	6
-1	1.13	1.08	1.01	0.93	0.83	0.69	0.52	—	—	1/4
	2.16	2.07	1.94	1.79	1.60	1.33	0.94	—	—	1/2
	7.70	7.36	6.92	6.37	5.68	4.73	3.53	—	—	1
	16.22	15.51	14.59	13.42	11.97	9.97	7.40	—	—	3
	24.16	23.10	21.73	19.98	17.83	14.85	11.01	—	—	5
	29.79	28.49	26.81	24.65	21.99	18.31	13.60	—	—	6
-7	1.08	1.03	0.94	0.84	0.71	0.53	—	—	—	1/4
	2.07	1.97	1.81	1.61	1.36	1.08	—	—	—	1/2
	7.39	7.00	6.45	5.74	4.83	3.70	—	—	—	1
	15.57	14.75	13.59	12.10	10.18	7.79	—	—	—	3
	23.19	21.97	20.24	18.03	15.16	11.61	—	—	—	5
	28.60	27.10	24.96	22.24	18.70	14.30	—	—	—	6
-12	1.02	0.94	0.84	0.71	0.53	—	—	—	—	1/4
	1.96	1.81	1.62	1.36	1.04	—	—	—	—	1/2
	6.96	6.43	5.76	4.84	3.68	—	—	—	—	1
	14.67	13.55	12.15	10.20	7.74	—	—	—	—	3
	21.85	20.18	18.09	15.20	11.50	—	—	—	—	5
	26.95	24.89	22.31	18.74	14.17	—	—	—	—	6
-18	0.93	0.83	0.71	0.53	—	—	—	—	—	1/4
	1.79	1.60	1.35	1.04	—	—	—	—	—	1/2
	6.36	5.69	4.82	3.73	—	—	—	—	—	1
	13.40	12.00	10.15	7.86	—	—	—	—	—	3
	19.96	17.87	15.12	11.71	—	—	—	—	—	5
	24.62	22.04	18.65	14.43	—	—	—	—	—	6

Note: All capacities shown are at 100% duty cycle (zero reserve capacity). Sizing is recommended for 50-80% duty cycle to accommodate load fluctuations. The refrigerant entering the valve must be in the liquid phase.

***Selection example (tons)***

**Design conditions**..... Cooling capacity = 5,000 Btuh or 0.42 Tons  
..... Evaporator temperature = -15°F  
..... Entering liquid temperature = 50°F

**Procedure:**

1. Calculate nominal capacity at 80% Duty Cycle = 0.42 Tons / 0.8 = 0.53 Tons
2. Calculate nominal capacity at 50% Duty Cycle = 0.42 Tons / 0.5 = 0.84 Tons
3. From R-744 Extended Capacity Tables, select Valve Size nearest to target range of 0.53 to 0.84 Tons at Design Conditions.

**Selection = PM 1/2** has capacity of 0.58 Tons  
Estimated duty cycle = 0.42/0.58 = 72%

***Selection example (kW)***

**Design conditions**.....Cooling capacity = 1.47 kW  
..... Evaporator temperature = -26°C  
..... Entering liquid temperature = 10°C

**Procedure:**

1. Calculate nominal capacity at 80% Duty Cycle = 1.47 kW / 0.8 = 1.84 kW
2. Calculate nominal capacity at 50% Duty Cycle = 1.47 kW / 0.5 = 2.94 kW
3. From R-744 Extended Capacity Tables, select Valve Size nearest to target range of 1.84 to 2.94 kW at Design Conditions.

**Selection = PM 1/2** has capacity of 2.02 kW  
Estimated duty cycle = 1.47/2.02 = 72%

# Electronic expansion valves capacity tables

R-22 extended capacities (tons) - EX4-8 series, as expansion and liquid injection valves

The following tables provide the capacity of valves at different conditions considering 20 psi pressure drop through liquid line:

Valve type	Condensing temperature (°f)	Evaporating temperature (°f)											
		60	50	40	30	20	10	0	-10	-20	-30	-40	-50
EX4	140	5	5	5	5	5	5	5	5	5	5	5	5
EX5		15	15	15	16	16	16	16	15	15	15	15	15
EX6		35	36	37	37	38	38	37	37	37	36	36	35
EX7		97	100	101	102	103	104	103	102	102	100	98	96
EX8		260	266	270	273	275	276	272	271	266	262	262	257
EX4	130	5	5	5	5	5	5	5	5	5	5	5	5
EX5		14	15	15	15	16	16	16	15	15	15	15	15
EX6		34	35	36	37	37	37	37	37	37	37	36	36
EX7		94	97	100	101	102	103	102	102	101	101	99	98
EX8		251	258	266	270	273	274	273	273	270	268	264	260
EX4	120	4	5	5	5	5	5	5	5	5	5	5	5
EX5		14	14	15	15	15	15	16	15	15	15	15	15
EX6		33	34	35	36	37	37	37	37	37	37	37	36
EX7		90	94	97	99	100	102	103	102	102	101	100	99
EX8		240	250	259	264	268	272	274	272	271	270	268	263
EX4	110	4	4	5	5	5	5	5	5	5	5	5	5
EX5		12	13	14	14	15	15	15	15	15	15	15	15
EX6		30	32	34	34	35	36	36	36	37	36	36	36
EX7		82	88	92	95	98	99	100	100	101	99	99	98
EX8		219	234	246	253	260	263	266	266	268	265	263	261
EX4	100	4	4	4	5	5	5	5	5	5	5	5	5
EX5		11	12	13	14	14	15	15	15	15	15	15	15
EX6		27	29	31	33	34	35	35	36	36	36	35	35
EX7		74	81	87	91	93	96	97	98	98	98	98	97
EX8		197	216	231	242	249	256	259	263	263	262	260	258
EX4	90	3	4	4	4	4	5	5	5	5	5	5	5
EX5		9	11	12	13	13	14	14	14	14	14	14	14
EX6		22	26	29	31	32	33	34	34	35	35	35	34
EX7		61	71	78	84	87	91	93	94	95	95	95	94
EX8		163	190	209	224	233	242	249	251	255	254	253	251
EX4	80	2	3	3	4	4	4	4	4	5	5	5	5
EX5		7	9	10	11	12	13	13	14	14	14	14	14
EX6		16	21	25	27	29	30	32	33	33	33	33	33
EX7		44	58	68	75	81	84	87	89	90	91	91	91
EX8		117	156	182	201	215	224	233	239	240	243	243	241
EX4	70	—	2	3	3	4	4	4	4	4	4	4	4
EX5		—	6	8	10	11	12	12	13	13	13	13	13
EX6		—	15	20	24	26	28	30	31	31	32	32	32
EX7		—	40	55	65	72	77	81	84	85	87	88	87
EX8		—	108	147	173	191	205	217	224	227	231	234	233
EX4	60	—	—	2	3	3	3	4	4	4	4	4	4
EX5		—	—	6	8	9	10	11	12	12	12	12	12
EX6		—	—	13	19	22	25	27	28	29	29	30	30
EX7		—	—	36	51	61	68	74	76	79	81	82	82
EX8		—	—	97	137	163	182	196	204	211	216	219	219
EX4	50	—	—	—	2	2	3	3	3	4	4	4	4
EX5		—	—	—	5	7	9	10	11	11	11	12	12
EX6		—	—	—	11	17	21	23	25	26	27	28	28
EX7		—	—	—	31	47	57	65	69	73	74	76	77
EX8		—	—	—	83	126	152	172	185	194	199	203	206

**R-23 extended capacities (tons) - EX4-8 series, as expansion and liquid injection valves**

The following tables provide the capacity of valves at different conditions considering 20 psi pressure drop through liquid line:

Valve type	Condensing temperature (°f)	Evaporating temperature (°f)									
		-50	-60	-70	-80	-90	-100	-110	-120	-130	-140
EX4	0	5	5	5	5	5	5	5	5	5	5
EX5		14	15	15	16	16	16	16	16	16	16
EX6		33	35	36	38	38	39	39	39	39	38
EX4	-10	4	4	5	5	5	5	5	5	5	5
EX5		12	13	14	15	15	15	16	15	16	15
EX6		29	32	34	35	36	37	37	37	37	37
EX4	-20	3	4	4	4	5	5	5	5	5	5
EX5		10	12	13	14	14	15	15	15	15	15
EX6		24	28	31	33	34	35	36	36	36	36
EX4	-30	2	3	4	4	4	4	5	5	5	5
EX5		7	9	11	12	13	13	14	14	14	14
EX6		17	23	26	29	31	32	33	33	33	34
EX4	-40	—	2	3	3	4	4	4	4	4	4
EX5		—	6	9	10	11	12	12	13	13	13
EX6		—	16	21	25	27	29	30	31	31	31
EX4	-50	—	—	2	3	3	3	4	4	4	4
EX5		—	—	5	8	9	10	11	11	12	12
EX6		—	—	13	19	23	25	26	27	28	28

**R-124 extended capacities (tons) - EX4-8 series, as expansion and liquid injection valves**

The following tables provide the capacity of valves at different conditions considering 20 psi pressure drop through liquid line:

Valve type	Condensing temperature (°f)	Evaporating temperature (°f)				
		80	70	60	50	40
EX4	210	2	2	2	2	2
EX5		6	6	6	5	5
EX6		15	14	13	13	12
EX4	200	2	2	2	2	2
EX5		7	6	6	6	6
EX6		16	15	15	14	14
EX4	190	2	2	2	2	2
EX5		7	7	7	7	6
EX6		17	17	17	16	15
EX4	180	3	2	2	2	2
EX5		8	8	7	7	7
EX6		18	18	18	17	17
EX4	170	3	3	2	2	2
EX5		8	8	8	7	7
EX6		18	18	18	18	17
EX4	160	3	3	3	3	3
EX5		8	8	8	8	8
EX6		18	19	19	18	18
EX4	150	2	2	3	3	3
EX5		7	8	8	8	8
EX6		18	18	18	18	18



Capacity Tables (kW)

R-134A extended capacities (tons) - EX4-8 series, as expansion and liquid injection valves

The following tables provide the capacity of valves at different conditions considering 20 psi pressure drop through liquid line:

Valve type	Condensing temperature (°f)	Evaporating temperature (°f)								
		60	50	40	30	20	10	0	-10	-20
EX4	140	4	4	4	4	4	4	4	3	3
EX5		11	11	11	11	11	11	11	11	10
EX6		27	27	27	27	27	26	26	25	25
EX7		74	75	75	75	73	73	71	69	68
EX8		197	200	200	199	196	194	190	185	181
EX4	130	4	4	4	4	4	4	4	4	3
EX5		11	11	11	11	11	11	11	11	10
EX6		26	26	27	27	27	27	26	26	25
EX7		72	73	74	74	73	73	72	70	69
EX8		191	194	198	197	196	194	192	187	183
EX4	120	3	4	4	4	4	4	4	4	4
EX5		10	11	11	11	11	11	11	11	11
EX6		25	26	26	27	27	27	26	26	25
EX7		68	71	73	73	73	73	72	71	70
EX8		182	188	194	196	195	195	193	189	186
EX4	110	3	3	3	4	4	4	4	4	3
EX5		10	10	11	11	11	11	11	11	11
EX6		23	24	25	26	26	26	26	26	25
EX7		63	65	69	70	71	71	71	70	69
EX8		168	176	183	187	189	191	189	188	184
EX4	100	3	3	3	3	3	3	3	3	3
EX5		9	9	10	10	10	11	11	11	10
EX6		20	22	24	24	25	25	25	25	25
EX7		56	60	65	67	69	69	69	69	68
EX8		149	161	173	178	183	184	185	184	182
EX4	90	2	3	3	3	3	3	3	3	3
EX5		7	8	9	9	10	10	10	10	10
EX6		16	19	21	22	23	24	24	24	24
EX7		44	52	58	61	64	66	66	66	66
EX8		118	139	153	163	170	175	177	176	177
EX4	80	1	2	2	3	3	3	3	3	3
EX5		4	6	7	8	9	9	9	10	10
EX6		10	15	18	20	21	22	23	23	23
EX7		27	40	49	54	58	60	62	62	63
EX8		72	107	130	144	154	160	165	166	167
EX4	70	—	1	2	2	3	3	3	3	3
EX5		—	3	6	7	8	8	9	9	9
EX6		—	8	13	16	18	20	21	21	22
EX7		—	22	37	45	50	54	57	59	59
EX8		—	58	98	120	134	145	152	156	158
EX4	60	—	—	1	2	2	2	3	3	3
EX5		—	—	2	5	6	7	8	8	8
EX6		—	—	5	12	15	17	18	19	20
EX7		—	—	14	32	40	46	50	52	53
EX8		—	—	38	84	107	122	133	139	143
EX4	50	—	—	—	—	1	2	2	2	2
EX5		—	—	—	—	4	5	6	7	7
EX6		—	—	—	—	9	13	15	16	17
EX7		—	—	—	—	26	36	42	45	48
EX8		—	—	—	—	69	95	111	120	128

R-404A/R-507 extended capacities (tons) - EX4-8 series, as expansion and liquid injection valves

The following tables provide the capacity of valves at different conditions considering 20 psi pressure drop through liquid line:

Valve type	Condensing temperature (°f)	Evaporating temperature (°f)											
		60	50	40	30	20	10	0	-10	-20	-30	-40	-50
EX4	130	3	3	3	3	3	3	3	3	3	2	2	2
EX5		9	9	9	9	9	9	8	8	8	8	7	7
EX6		21	21	22	21	21	21	20	20	19	18	17	16
EX7		58	59	59	58	58	57	56	54	52	50	48	45
EX8		153	156	157	156	154	152	148	143	139	133	127	120
EX4	120	3	3	3	3	3	3	3	3	3	3	3	3
EX5		9	9	9	10	9	9	9	9	9	9	8	8
EX6		22	22	23	23	23	23	22	22	21	20	20	19
EX7		59	61	62	63	62	62	61	60	58	56	54	52
EX8		158	162	165	168	166	165	163	169	165	149	144	138
EX4	110	3	3	3	3	3	3	3	3	3	3	3	3
EX5		9	9	10	10	10	10	10	9	9	9	9	8
EX6		21	22	23	23	23	23	23	23	22	22	21	20
EX7		58	60	63	63	64	64	63	62	61	59	58	56
EX8		153	161	167	168	170	171	168	165	163	158	154	148
EX4	100	3	3	3	3	3	3	3	3	3	3	3	3
EX5		8	9	9	10	10	10	10	10	10	10	9	9
EX6		20	21	23	23	24	24	24	24	23	23	22	22
EX7		54	59	62	64	65	66	66	66	64	63	62	59
EX8		145	156	165	171	174	175	176	173	171	168	164	158
EX4	90	2	3	3	3	3	3	3	3	3	3	3	3
EX5		7	8	9	9	10	10	10	10	10	10	10	9
EX6		17	20	21	23	23	24	24	24	24	23	23	23
EX7		48	54	58	62	64	65	66	66	66	64	63	62
EX8		127	144	156	164	170	173	176	176	175	171	169	165
EX4	80	2	2	3	3	3	3	3	3	3	3	3	3
EX5		6	7	8	9	9	10	10	10	10	10	10	9
EX6		13	17	19	21	22	23	23	24	24	23	23	23
EX7		37	46	53	58	61	63	64	65	65	64	63	62
EX8		98	124	142	154	162	168	171	173	172	171	169	166
EX4	70	1	2	2	3	3	3	3	3	3	3	3	3
EX5		2	5	7	8	9	9	9	10	10	10	10	10
EX6		6	13	17	19	21	22	23	23	24	23	23	23
EX7		16	35	46	52	57	60	62	64	64	64	64	63
EX8		42	94	122	138	152	160	166	170	172	170	170	168
EX4	60	—	1	2	2	2	3	3	3	3	3	3	3
EX5		—	2	5	7	8	8	9	9	9	9	9	9
EX6		—	4	12	16	18	20	21	22	22	22	23	22
EX7		—	11	33	43	50	55	58	60	61	62	62	61
EX8		—	30	89	116	133	146	155	159	163	164	165	162
EX4	50	—	—	—	2	2	2	3	3	3	3	3	3
EX5		—	—	—	5	6	7	8	9	9	9	9	9
EX6		—	—	—	11	15	18	19	20	21	21	22	22
EX7		—	—	—	31	42	48	53	56	58	59	60	59
EX8		—	—	—	82	111	128	142	149	154	157	160	158
EX4	40	—	—	—	—	1	2	2	2	3	3	3	3
EX5		—	—	—	—	4	6	7	8	8	8	8	9
EX6		—	—	—	—	10	14	17	18	19	20	20	21
EX7		—	—	—	—	27	38	46	50	53	55	56	56
EX8		—	—	—	—	72	102	122	133	142	146	149	150

R-407C extended capacities (tons) - EX4-8 series, as expansion and liquid injection valves

The following tables provide the capacity of valves at different conditions considering 20 psi pressure drop through liquid line:

Valve type	Condensing temperature Bubble point (°f)	Evaporating temperature (°f)							
		60	50	40	30	20	10	0	-10
EX4	140	5	5	5	5	5	5	5	5
EX5		14	15	15	15	15	15	14	14
EX6		34	35	35	35	35	35	34	33
EX7		95	97	97	97	96	95	94	92
EX8		253	257	258	259	256	255	250	244
EX4	130	5	5	5	5	5	5	5	5
EX5		15	15	15	15	15	15	15	14
EX6		35	35	36	36	36	35	35	34
EX7		95	96	98	98	98	97	96	94
EX8		253	257	261	261	261	260	256	252
EX4	120	5	5	5	5	5	5	5	5
EX5		14	15	15	15	15	15	15	15
EX6		34	35	36	36	36	36	36	36
EX7		93	96	99	99	99	100	99	98
EX8		249	256	264	265	265	266	264	261
EX4	110	4	5	5	5	5	5	5	5
EX5		14	14	15	15	15	15	15	15
EX6		33	34	35	35	36	36	36	35
EX7		90	93	96	97	99	99	99	98
EX8		239	248	255	260	263	264	263	260
EX4	100	4	4	5	5	5	5	5	5
EX5		13	14	14	15	15	15	15	15
EX6		30	32	34	35	35	36	36	36
EX7		84	89	94	96	98	99	99	98
EX8		224	239	250	256	260	263	254	262
EX4	90	4	4	4	5	5	5	5	5
EX5		11	13	13	14	14	15	15	15
EX6		27	30	32	33	34	35	35	35
EX7		75	83	87	92	94	96	97	96
EX8		201	220	233	244	250	256	259	257
EX4	80	3	4	4	4	4	5	5	5
EX5		10	11	12	13	13	14	14	14
EX6		23	26	29	31	32	33	34	34
EX7		63	73	80	85	88	91	93	93
EX8		169	193	212	227	235	243	247	248
EX4	70	2	3	4	4	4	4	4	4
EX5		7	9	11	12	13	13	14	14
EX6		17	22	26	28	30	31	32	33
EX7		47	61	71	77	83	87	89	90
EX8		125	164	190	206	220	231	236	239
EX4	60	0	2	3	3	4	4	4	4
EX5		2	7	9	10	11	12	13	13
EX6		4	16	21	24	27	29	30	31
EX7		10	43	58	67	74	79	82	85
EX8		26	115	154	179	197	211	219	225
EX4	50	—	—	2	3	3	4	4	4
EX5		—	—	6	8	10	11	12	12
EX6		—	—	15	20	23	26	27	29
EX7		—	—	40	55	64	70	75	79
EX8		—	—	107	146	170	187	201	210

R-410A extended capacities (tons) - EX4-8 series, as expansion and liquid injection valves

The following tables provide the capacity of valves at different conditions considering 20 psi pressure drop through liquid line:

Valve type	Condensing temperature (°f)	Evaporating temperature (°f)												
		60	50	40	30	20	10	0	-10	-20	-30	-40	-50	
EX4	140	5	5	5	5	5	5	5	5	5	5	5	5	
EX5		15	15	16	16	16	16	16	16	16	15	15	15	
EX6		36	37	38	38	38	38	38	38	38	37	37	36	35
EX7		99	102	104	105	105	105	105	105	104	103	101	99	97
EX8		265	271	277	279	281	281	280	277	274	269	264	258	
EX4	130	5	5	5	5	6	6	6	6	5	5	5	5	
EX5		15	16	16	16	17	17	17	17	16	16	16	16	
EX6		37	38	39	40	40	40	40	40	40	39	39	38	
EX7		101	105	107	109	110	110	111	110	109	108	106	104	
EX8		269	279	285	292	293	295	296	294	291	288	283	277	
EX4	120	5	5	6	6	6	6	6	6	6	6	6	6	
EX5		15	16	17	17	17	17	17	17	17	17	17	17	
EX6		37	39	40	41	42	42	42	42	42	42	41	40	
EX7		101	106	110	112	114	115	116	116	116	114	113	111	
EX8		270	283	293	299	305	308	309	310	309	305	301	297	
EX4	110	5	5	5	6	6	6	6	6	6	6	6	6	
EX5		15	15	16	17	17	17	18	18	18	17	17	17	
EX6		35	37	39	40	42	42	43	43	43	42	42	41	
EX7		96	102	107	111	114	115	117	118	117	116	115	113	
EX8		257	273	286	297	305	308	313	314	313	309	308	303	
EX4	100	5	5	5	6	6	6	6	6	6	6	6	6	
EX5		14	15	16	17	17	17	18	18	18	18	18	18	
EX6		33	36	38	40	41	42	43	43	43	43	43	42	
EX7		90	98	105	110	113	116	118	119	119	118	118	116	
EX8		240	261	281	294	301	308	315	316	316	315	316	311	
EX4	90	4	4	5	5	5	6	6	6	6	6	6	6	
EX5		12	13	15	16	16	17	17	18	18	18	18	18	
EX6		28	33	36	38	40	41	42	42	43	43	43	43	
EX7		78	89	98	104	109	112	116	116	118	118	118	117	
EX8		207	239	260	277	290	300	308	311	314	314	315	313	
EX4	80	3	4	4	5	5	5	6	6	6	6	6	6	
EX5		9	12	13	15	15	16	17	17	17	17	17	17	
EX6		22	28	32	35	37	39	40	41	42	42	42	42	
EX7		61	77	87	97	103	107	111	113	114	116	115	114	
EX8		163	204	233	257	274	286	297	300	305	309	308	305	
EX4	70	2	3	4	4	5	5	5	5	6	6	6	6	
EX5		5	9	11	13	14	15	16	16	17	17	17	17	
EX6		11	21	27	31	34	37	39	39	40	41	41	41	
EX7		31	59	75	86	94	101	106	108	111	112	114	113	
EX8		84	157	201	230	251	270	284	289	295	300	303	301	
EX4	60	—	1	3	4	4	5	5	5	5	5	5	5	
EX5		—	4	8	11	13	14	15	15	16	16	16	16	
EX6		—	10	20	26	30	33	36	37	38	39	40	39	
EX7		—	27	56	72	84	92	98	102	105	108	109	109	
EX8		—	72	150	192	224	245	262	273	281	287	291	290	
EX4	50	—	—	1	3	3	4	4	5	5	5	5	5	
EX5		—	—	3	8	10	12	14	14	15	15	16	16	
EX6		—	—	8	19	25	29	33	35	36	37	38	38	
EX7		—	—	21	53	69	80	90	95	99	102	104	104	
EX8		—	—	57	143	185	214	239	254	265	272	278	277	

R-448A extended capacities (tons) - EX4-8 series, as expansion and liquid injection valves

The following tables provide the capacity of valves at different conditions considering 20 psi pressure drop through liquid line:

Valve type	Condensing temperature (°f)	Evaporating temperature (°f)															
		50	40	32	25	15	0	-10	-20	-30	-40	-50	-60	-70	-80	-95	
EX4	140	4.3	4.3	4.3	4.3	4.3	4.2	4.1	4.0	3.9	3.7	3.6	3.5	3.3	3.2	2.9	
EX5		13.1	13.1	13.1	13.1	12.8	12.7	12.3	12.0	11.7	11.4	11.0	10.4	10.2	9.8	9.0	
EX6		31.3	31.6	31.6	31.3	31.0	30.3	29.6	28.9	28.0	27.3	26.3	25.1	24.2	23.2	21.5	
EX7		86.4	86.7	86.7	86.3	85.4	83.4	81.6	79.5	77.3	74.8	72.2	69.4	66.5	63.7	59.1	
EX8		230.3	231.2	230.9	229.9	227.5	222.1	217.4	211.9	205.9	199.3	192.4	185.0	177.4	169.4	157.6	
EX4	120	4.5	4.5	4.6	4.6	4.6	4.6	4.5	4.4	4.3	4.2	4.1	4.0	3.9	3.7	3.6	
EX5		13.3	13.7	14.0	14.0	14.0	13.9	13.5	13.5	13.2	12.9	12.6	12.2	11.7	11.4	10.9	
EX6		32.4	33.1	33.3	33.4	33.4	33.0	32.8	32.2	31.6	31.0	30.0	29.1	28.2	27.3	25.8	
EX7		88.9	90.6	91.4	91.8	92.0	91.1	90.0	88.6	86.8	84.9	82.7	80.2	77.8	75.2	71.2	
EX8		237.1	241.9	244.2	245.2	245.4	243.0	240.2	236.1	231.6	226.1	220.5	214.1	207.3	200.7	189.7	
EX4	100	4.2	4.4	4.5	4.5	4.6	4.6	4.6	4.6	4.5	4.4	4.4	4.3	4.2	4.1	3.9	
EX5		12.6	13.2	13.5	13.8	13.9	13.9	13.9	13.9	13.7	13.4	13.1	12.8	12.5	12.2	11.7	
EX6		30.5	31.8	32.4	32.9	33.3	33.5	33.6	33.1	32.8	32.3	31.7	31.0	30.2	29.6	28.2	
EX7		83.7	87.3	89.3	90.6	91.8	92.3	92.0	91.3	90.2	88.7	87.2	85.3	83.3	80.9	77.6	
EX8		223.3	232.7	238.1	241.6	244.6	246.2	245.4	243.6	240.6	236.9	232.4	227.4	221.9	216.1	207.1	
EX4	85	3.7	4.0	4.1	4.3	4.4	4.5	4.5	4.5	4.4	4.4	4.3	4.2	4.1	4.0		
EX5		11.2	11.9	12.7	13.0	13.3	13.6	13.6	13.6	13.7	13.4	13.3	13.0	12.7	12.4	11.9	
EX6		26.6	28.9	30.2	31.2	32.0	32.8	33.0	32.7	32.7	32.4	31.8	31.1	30.5	29.9	28.9	
EX7		73.4	79.3	83.0	85.4	87.9	89.9	90.3	90.4	89.9	88.7	87.4	86.1	84.1	82.2	79.4	
EX8		195.7	211.9	221.3	227.6	234.3	239.7	241.0	240.8	239.2	236.7	233.3	229.4	224.6	219.7	211.4	
EX4	70	2.8	3.3	3.6	3.8	4.0	4.2	4.3	4.3	4.3	4.3	4.3	4.2	4.1	4.1	3.9	
EX5		8.4	10.0	11.0	11.5	12.1	12.9	13.0	13.2	13.2	13.2	12.9	12.8	12.5	12.5	11.8	
EX6		20.3	24.1	26.3	27.7	29.4	30.7	31.3	31.6	31.6	31.3	31.2	30.7	30.1	29.7	28.5	
EX7		55.6	66.1	72.1	76.2	80.6	84.6	86.2	86.9	86.8	86.3	85.5	84.3	82.8	81.0	78.3	
EX8		148.6	176.5	192.5	203.3	214.7	225.5	229.5	231.3	231.4	230.4	228.0	224.8	221.0	216.4	208.8	
EX4	60	2.8	3.1	3.3	3.5	3.7	3.8	3.9	4.0	4.0	4.1	4.1	4.1	4.1	4.1	4.1	
EX5		8.4	9.5	10.1	10.5	11.0	11.7	11.8	12.1	12.3	12.4	12.3	12.4	12.4	12.5	12.4	
EX6		20.3	22.8	24.4	25.3	26.6	27.8	28.5	29.1	29.4	29.4	29.8	29.8	29.8	29.9	29.7	
EX7		55.6	62.6	66.7	69.7	73.1	76.7	78.5	79.8	80.6	81.3	81.7	81.9	81.9	81.8	81.6	
EX8		148.4	167.0	178.2	186.1	194.9	204.6	209.2	212.5	214.9	216.7	217.7	218.3	218.5	218.3	217.5	
EX4	50	2.9	3.0	3.1	3.2	3.2	3.4	3.5	3.6	3.6	3.7	3.8	3.9	4.0	4.1	4.2	
EX5		8.9	9.1	9.4	9.6	9.8	10.2	10.5	10.8	11.0	11.3	11.6	11.9	12.1	12.4	12.8	
EX6		21.4	22.0	22.6	23.0	23.6	24.6	25.3	25.9	26.5	27.2	27.8	28.5	29.1	29.8	30.7	
EX7		58.8	60.5	62.0	63.2	65.0	67.7	69.4	71.2	73.0	74.8	76.6	78.3	80.1	81.9	84.6	
EX8		156.9	161.6	165.4	168.7	173.4	180.4	185.1	189.8	194.6	199.3	204.0	208.7	213.4	218.1	225.2	
EX4	32	2.2	2.3	2.4	2.5	2.6	2.7	2.9	3.0	3.1	3.2	3.3	3.4	3.5	3.7	3.8	
EX5		6.7	7.0	7.3	7.5	7.9	8.4	8.7	9.0	9.4	9.7	10.0	10.4	10.7	11.0	11.5	
EX6		15.8	16.7	17.3	17.9	18.7	20.0	20.8	21.7	22.5	23.3	24.2	25.0	25.9	26.7	27.9	
EX7		43.4	45.7	47.6	49.2	51.5	55.0	57.3	59.6	61.9	64.2	66.5	68.8	71.1	73.4	76.9	
EX8		115.9	122.0	126.9	131.2	137.3	146.5	152.6	158.7	164.9	171.0	177.1	183.2	189.3	195.5	204.6	
EX4	15	—	1.3	1.4	1.6	1.7	1.9	2.1	2.2	2.4	2.5	2.7	2.8	3.0	3.1	3.4	
EX5		—	4.0	4.3	4.6	5.1	5.8	6.2	6.7	7.2	7.6	8.1	8.5	9.0	9.5	10.1	
EX6		—	9.6	10.5	11.2	12.3	14.0	15.1	16.2	17.3	18.3	19.4	20.5	21.6	22.7	24.3	
EX7		—	26.3	28.7	30.8	33.9	38.4	41.4	44.5	47.5	50.5	53.5	56.6	59.6	62.6	67.1	
EX8		—	69.9	76.4	82.1	90.2	102.3	110.4	118.5	126.6	134.7	142.7	150.8	158.9	166.9	179.0	
EX4	-5	—	—	—	—	—	—	1.0	1.2	1.4	1.5	1.7	1.9	2.1	2.2	2.5	
EX5		—	—	—	—	—	—	—	3.1	3.7	4.2	4.7	5.2	5.7	6.3	7.6	
EX6		—	—	—	—	—	—	—	7.4	8.7	9.9	11.1	12.4	13.6	14.9	17.9	
EX7		—	—	—	—	—	—	—	20.6	24.0	27.4	30.8	34.2	37.5	40.9	44.3	49.4
EX8		—	—	—	—	—	—	—	55.2	64.2	73.2	82.2	91.2	100.3	109.3	118.3	131.8

R-449A extended capacities (tons) - EX4-8 series, as expansion and liquid injection valves

The following tables provide the capacity of valves at different conditions considering 20 psi pressure drop through liquid line:

Valve type	Condensing temperature (°f)	Evaporating temperature (°f)											
		50	40	30	20	10	0	-10	-20	-30	-40	-80	-100
EX4	140	4.3	4.3	4.3	4.3	4.1	3.9	4.0	3.8	3.7	3.7	3.1	2.7
EX5		12.8	12.8	12.7	12.5	12.4	12.2	12.1	11.7	11.4	10.8	9.2	8.2
EX6		30.4	30.7	30.4	30.4	29.9	29.2	28.7	27.8	27.1	26.2	22.0	19.9
EX7		83.9	84.2	83.8	83.1	82.0	80.6	78.8	76.6	74.4	71.9	60.8	54.8
EX8		223.5	224.4	223.8	221.7	218.8	214.8	210.0	204.5	198.3	191.6	162.1	145.8
EX4	120	4.3	4.3	4.6	4.6	4.6	4.4	4.3	4.3	4.3	4.0	3.7	3.3
EX5		13.1	13.4	13.4	13.4	13.4	13.5	13.3	13.0	12.7	12.4	11.1	10.1
EX6		31.5	32.2	32.5	32.5	32.5	32.2	31.7	31.1	30.5	29.9	26.4	24.5
EX7		86.6	88.3	89.0	89.4	89.3	88.6	87.3	85.7	83.9	82.1	72.4	67.0
EX8		231.0	235.4	237.8	238.6	237.9	235.9	232.8	228.8	224.2	218.8	192.9	178.5
EX4	100	4.2	4.2	4.3	4.5	4.5	4.6	4.6	4.5	4.3	4.3	4.0	3.7
EX5		12.3	13.0	13.3	13.6	13.6	13.6	13.7	13.4	13.4	13.1	11.9	11.3
EX6		29.7	31.0	31.9	32.3	32.6	32.7	32.5	32.3	32.0	31.4	28.7	26.8
EX7		81.8	85.1	87.7	89.1	89.8	89.9	89.8	88.8	87.7	86.3	78.3	74.0
EX8		218.4	227.5	233.5	237.6	239.7	240.2	239.2	237.0	234.0	230.3	209.5	197.3
EX4	85	3.6	3.9	4.0	4.3	4.2	4.4	4.6	4.3	4.3	4.3	3.9	4.1
EX5		10.9	11.9	12.5	12.8	13.2	13.4	13.3	13.3	13.4	13.1	12.1	11.5
EX6		26.0	28.3	29.9	30.9	31.6	31.9	32.1	32.1	31.9	31.6	28.9	27.8
EX7		72.0	77.6	82.0	84.8	86.8	87.7	88.3	88.2	87.6	86.7	80.0	76.2
EX8		191.5	207.4	218.4	226.3	231.3	234.4	235.4	235.2	233.6	230.8	213.7	202.3
EX4	70	2.6	3.2	3.5	3.9	4.1	4.0	4.3	4.3	4.3	4.3	4.0	4.0
EX5		8.4	9.7	10.9	11.8	12.3	12.6	12.7	12.9	12.9	12.9	12.2	11.3
EX6		19.7	23.5	26.2	28.0	29.4	30.0	30.7	30.8	30.7	30.7	28.7	27.4
EX7		54.5	64.9	71.8	76.9	80.5	82.7	84.1	84.8	84.8	84.3	79.3	75.2
EX8		145.4	172.9	191.7	205.2	214.6	220.9	224.6	226.3	226.5	225.1	211.0	200.7
EX4	50	2.8	2.9	3.0	3.1	3.2	3.3	3.4	3.5	3.6	3.7	4.0	4.2
EX5		8.7	9.0	9.2	9.5	9.8	10.0	10.3	10.5	10.8	11.1	12.1	12.6
EX6		20.9	21.6	22.2	22.8	23.5	24.1	24.7	25.4	26.0	26.6	29.2	30.5
EX7		57.7	59.4	61.1	62.8	64.6	66.3	68.0	69.7	71.5	73.2	80.1	83.5
EX8		153.8	158.4	163.0	167.6	172.2	176.8	181.4	186.0	190.5	195.1	213.5	222.6
EX4	32	2.2	2.3	2.4	2.5	2.6	2.7	2.8	3.0	3.1	3.2	3.6	3.8
EX5		6.4	6.7	7.1	7.4	7.8	8.1	8.5	8.8	9.2	9.5	10.9	11.6
EX6		15.4	16.2	17.0	17.8	18.7	19.5	20.3	21.1	22.0	22.8	26.1	27.7
EX7		42.7	44.9	47.2	49.4	51.6	53.9	56.1	58.4	60.6	62.9	71.8	76.3
EX8		113.6	119.6	125.6	131.6	137.6	143.6	149.6	155.6	161.6	167.5	191.5	203.5
EX4	15	—	—	1.5	1.6	1.8	1.9	2.1	2.2	2.3	2.5	3.0	3.3
EX5		—	—	4.3	4.8	5.2	5.7	6.1	6.6	7.1	7.5	9.3	10.2
EX6		—	—	10.4	11.5	12.6	13.7	14.8	15.8	16.9	18.0	22.3	24.5
EX7		—	—	28.5	31.5	34.5	37.5	40.4	43.4	46.4	49.4	61.3	67.3
EX8		—	—	76.0	84.0	92.0	100.0	108.0	116.0	123.9	131.9	163.7	179.6
EX4	-5	—	—	—	—	—	—	1.0	1.2	1.3	1.5	2.2	2.5
EX5		—	—	—	—	—	—	3.1	3.6	4.1	4.6	6.6	7.6
EX6		—	—	—	—	—	—	7.1	8.4	9.6	10.9	15.8	18.3
EX7		—	—	—	—	—	—	20.1	23.5	26.8	30.1	43.5	50.1
EX8		—	—	—	—	—	—	53.4	62.3	71.3	80.2	115.8	133.6

R-450A extended capacities (tons) - EX4-8 series, as expansion and liquid injection valves

The following tables provide the capacity of valves at different conditions considering 20 psi pressure drop through liquid line:

Valve type	Condensing temperature (°f)	Evaporating temperature (°f)											
		130	120	100	80	60	50	40	30	20	0	-10	-20
EX4	175	2.6	2.8	3.0	3.0	2.9	2.9	2.8	2.7	2.6	2.3	2.2	2.1
EX5		7.9	8.6	8.9	9.2	8.9	8.6	8.6	8.2	8.0	7.0	6.7	6.4
EX6		19.0	20.3	21.8	22.0	21.5	21.0	20.3	19.7	19.0	17.0	16.1	15.1
EX7		52.1	55.8	59.7	60.4	59.1	57.7	56.1	54.1	51.9	47.0	44.2	41.5
EX8		139.0	148.8	159.2	161.2	157.3	153.8	149.4	144.2	138.4	125.1	118.1	110.6
EX4	160	2.2	2.6	3.0	3.2	3.2	3.1	3.1	3.0	2.9	2.7	2.6	2.4
EX5		6.8	8.0	9.1	9.6	9.6	9.4	9.4	9.1	9.0	8.2	7.9	7.5
EX6		16.4	18.9	21.7	23.0	23.1	22.8	22.4	22.0	21.3	19.5	18.6	17.7
EX7		45.0	52.2	59.8	63.2	63.4	62.7	61.6	60.0	58.2	53.9	51.5	48.8
EX8		120.3	138.8	159.9	168.6	169.3	167.4	164.3	160.4	155.5	143.6	137.0	130.0
EX4	140	2.4	2.5	2.6	2.7	2.8	2.8	2.9	2.9	3.0	3.1	3.1	3.2
EX5		7.4	7.6	7.9	8.1	8.4	8.6	8.7	8.9	9.0	9.3	9.5	9.6
EX6		17.8	18.2	18.9	19.6	20.3	20.6	21.0	21.4	21.7	22.4	22.8	23.1
EX7		49.0	49.9	51.9	53.8	55.8	56.7	57.7	58.7	59.6	61.6	62.6	63.5
EX8		130.6	133.2	138.3	143.5	148.7	151.3	153.9	156.4	159.0	164.2	166.8	169.4
EX4	120	2.5	2.6	2.7	2.7	2.8	2.9	2.9	3.0	3.0	3.1	3.1	3.2
EX5		7.8	7.9	8.1	8.4	8.6	8.7	8.9	9.0	9.1	9.3	9.5	9.6
EX6		18.5	18.8	19.4	20.0	20.6	20.9	21.2	21.5	21.8	22.4	22.7	23.0
EX7		50.6	51.5	53.2	54.9	56.6	57.4	58.2	59.1	59.9	61.6	62.4	63.2
EX8		135.0	137.4	141.9	146.4	150.9	153.1	155.3	157.6	159.8	164.2	166.4	168.6
EX4	110	2.1	2.2	2.3	2.5	2.6	2.7	2.8	2.9	2.9	3.1	3.2	3.3
EX5		6.3	6.5	7.0	7.5	7.9	8.2	8.4	8.7	8.9	9.4	9.6	9.9
EX6		15.1	15.7	16.8	18.0	19.1	19.7	20.2	20.8	21.4	22.5	23.1	23.7
EX7		41.5	43.1	46.2	49.3	52.5	54.1	55.6	57.2	58.8	61.9	63.5	65.1
EX8		110.9	115.0	123.3	131.7	140.0	144.2	148.4	152.6	156.8	165.2	169.4	173.6
EX4	105	1.9	2.0	2.2	2.4	2.5	2.6	2.7	2.8	2.9	3.0	3.1	3.2
EX5		5.9	6.2	6.7	7.2	7.7	7.9	8.2	8.4	8.6	9.1	9.4	9.6
EX6		14.2	14.8	16.0	17.2	18.4	19.0	19.6	20.2	20.8	21.9	22.5	23.1
EX7		39.3	40.9	44.1	47.3	50.6	52.2	53.8	55.4	57.0	60.2	61.8	63.4
EX8		104.6	109.0	117.6	126.2	134.8	139.1	143.4	147.8	152.1	160.7	165.0	169.3
EX4	95	1.5	1.6	1.8	2.1	2.3	2.4	2.5	2.6	2.8	3.0	3.1	3.2
EX5		4.6	5.0	5.7	6.3	7.0	7.4	7.7	8.1	8.4	9.1	9.4	9.8
EX6		11.2	12.0	13.7	15.3	16.9	17.7	18.5	19.3	20.1	21.7	22.5	23.4
EX7		30.4	32.6	37.2	41.7	46.2	48.4	50.7	52.9	55.2	59.7	62.0	64.2
EX8		81.2	87.3	99.3	111.3	123.3	129.3	135.3	141.3	147.3	159.3	165.3	171.3
EX4	85	1.6	1.7	1.8	2.0	2.2	2.3	2.4	2.5	2.6	2.8	2.9	3.0
EX5		4.7	5.0	5.6	6.2	6.8	7.1	7.4	7.7	7.9	8.5	8.8	9.1
EX6		11.3	12.0	13.4	14.8	16.3	17.0	17.7	18.4	19.2	20.6	21.3	22.0
EX7		31.0	33.0	36.9	40.8	44.8	46.7	48.7	50.7	52.6	56.6	58.5	60.5
EX8		83.3	88.5	98.9	109.2	119.6	124.8	129.9	135.1	140.3	150.7	155.8	161.0
EX4	75	—	—	—	1.3	1.7	1.8	2.0	2.2	2.3	2.7	2.8	3.0
EX5		—	—	—	4.0	5.0	5.5	6.0	6.5	7.1	8.1	8.6	9.1
EX6		—	—	—	9.7	12.1	13.3	14.5	15.7	17.0	19.4	20.6	21.8
EX7		—	—	—	26.8	33.4	36.7	40.1	43.4	46.7	53.3	56.6	59.9
EX8		—	—	—	71.3	89.0	97.8	106.7	115.5	124.4	142.0	150.9	159.7

R-513A extended capacities (tons) - EX4-8 series, as expansion and liquid injection valves

The following tables provide the capacity of valves at different conditions considering 20 psi pressure drop through liquid line:

Valve type	Condensing temperature (°f)	Evaporating temperature (°f)											
		130	120	100	80	60	50	40	30	20	0	-10	-20
EX4	175	2.4	2.6	2.7	2.7	2.6	2.4	2.3	2.1	1.9	1.7	1.6	1.5
EX5		7.1	7.8	8.1	8.3	7.8	7.2	6.9	6.6	5.6	5.1	4.8	4.6
EX6		17.3	18.4	19.6	19.7	18.9	17.3	16.6	15.6	13.4	12.5	11.9	10.6
EX7		47.7	50.8	53.9	54.0	51.7	47.8	45.5	42.9	37.1	34.1	32.4	29.2
EX8		126.9	135.8	143.9	144.0	137.9	127.8	121.4	114.5	99.0	90.9	86.8	78.0
EX4	160	2.2	2.5	2.9	3.0	3.0	2.9	2.8	2.7	2.4	2.3	2.2	2.0
EX5		6.7	7.6	8.7	9.2	8.9	8.7	8.4	8.0	7.3	6.7	6.4	6.2
EX6		15.7	18.2	21.0	21.9	21.7	20.8	20.1	19.3	17.5	16.4	15.9	14.9
EX7		43.2	50.1	57.4	60.1	59.6	57.1	55.3	53.0	47.9	45.1	43.7	40.5
EX8		115.4	133.2	153.0	160.4	159.4	152.5	147.4	141.5	127.7	120.1	116.2	108.1
EX4	140	—	2.5	2.6	2.7	2.8	2.8	2.9	2.9	3.0	3.0	3.0	3.1
EX5		—	7.7	7.9	8.1	8.3	8.6	8.7	8.8	9.0	9.1	9.2	9.3
EX6		—	18.3	18.8	19.4	19.9	20.5	20.8	21.0	21.6	21.9	22.0	22.3
EX7		—	50.5	51.9	53.4	54.9	56.4	57.2	57.9	59.4	60.2	60.6	61.3
EX8		—	134.6	138.5	142.5	146.5	150.5	152.5	154.5	158.5	160.4	161.4	163.4
EX4	120	—	—	2.4	2.5	2.7	2.8	2.9	3.0	3.1	3.2	3.2	3.3
EX5		—	—	7.3	7.8	8.2	8.6	8.8	9.0	9.5	9.7	9.8	10.0
EX6		—	—	17.4	18.5	19.5	20.6	21.1	21.6	22.7	23.2	23.4	24.0
EX7		—	—	48.0	50.8	53.7	56.6	58.1	59.5	62.4	63.8	64.6	66.0
EX8		—	—	128.1	135.7	143.4	151.0	154.9	158.7	166.4	170.2	172.1	176.0
EX4	110	—	—	2.3	2.5	2.6	2.8	2.9	2.9	3.1	3.2	3.2	3.3
EX5		—	—	7.1	7.5	8.0	8.4	8.6	8.9	9.3	9.6	9.7	9.9
EX6		—	—	16.9	18.0	19.1	20.2	20.8	21.3	22.4	23.0	23.3	23.8
EX7		—	—	46.6	49.6	52.6	55.7	57.2	58.7	61.7	63.2	63.9	65.4
EX8		—	—	124.2	132.3	140.3	148.3	152.3	156.4	164.4	168.4	170.4	174.4
EX4	105	—	—	2.0	2.2	2.4	2.6	2.7	2.8	3.0	3.1	3.2	3.3
EX5		—	—	5.9	6.6	7.2	7.9	8.2	8.5	9.2	9.5	9.7	10.0
EX6		—	—	14.6	16.1	17.6	19.1	19.8	20.5	22.0	22.8	23.1	23.9
EX7		—	—	39.8	44.0	48.1	52.3	54.3	56.4	60.5	62.6	63.6	65.7
EX8		—	—	106.0	117.1	128.2	139.3	144.9	150.4	161.5	167.1	169.9	175.4
EX4	95	—	—	—	1.9	2.1	2.4	2.5	2.6	2.9	3.0	3.1	3.2
EX5		—	—	—	5.6	6.4	7.2	7.6	8.0	8.8	9.2	9.4	9.8
EX6		—	—	—	13.6	15.5	17.3	18.3	19.2	21.1	22.1	22.5	23.5
EX7		—	—	—	37.4	42.5	47.7	50.2	52.8	57.9	60.4	61.7	64.3
EX8		—	—	—	99.7	113.4	127.0	133.9	140.7	154.4	161.2	164.6	171.5
EX4	85	—	—	—	—	1.8	2.1	2.2	2.4	2.7	2.9	2.9	3.1
EX5		—	—	—	—	5.4	6.3	6.8	7.3	8.2	8.7	8.9	9.4
EX6		—	—	—	—	12.9	15.2	16.3	17.5	19.7	20.9	21.4	22.6
EX7		—	—	—	—	35.5	41.8	44.9	48.0	54.2	57.3	58.9	62.0
EX8		—	—	—	—	94.4	111.2	119.6	128.0	144.7	153.1	157.3	165.6
EX4	75	—	—	—	1.5	1.7	2.0	2.1	2.2	2.5	2.6	2.7	2.8
EX5		—	—	—	4.5	5.2	6.0	6.3	6.7	7.4	7.8	8.0	8.4
EX6		—	—	—	11.1	12.8	14.5	15.3	16.2	17.9	18.7	19.1	20.0
EX7		—	—	—	30.1	34.9	39.7	42.1	44.5	49.3	51.7	52.9	55.3
EX8		—	—	—	79.7	92.7	105.7	112.3	118.8	131.8	138.3	141.6	148.1

R-744 extended capacities (tons) - EX4-8 series, as expansion and liquid injection valves

The following tables provide the capacity of valves at different conditions considering 20 psi pressure drop through liquid line:

Valve type	Condensing temperature (°f)	Evaporating temperature (°f)						
		10	0	-10	-20	-30	-40	-50
EX4	30	6	7	8	9	10	10	10
EX5		18	22	25	27	29	30	31
EX6		43	53	60	65	70	73	75
EX7		117	145	165	179	191	200	206
EX8		312	388	439	479	510	534	549
EX4	20	—	6	7	8	9	9	10
EX5		—	18	22	25	27	29	30
EX6		—	43	53	60	65	69	72
EX7		—	119	145	164	178	189	197
EX8		—	319	387	437	476	506	526
EX4	10	—	—	6	7	8	9	9
EX5		—	—	18	22	25	27	29
EX6		—	—	43	53	60	65	68
EX7		—	—	119	145	163	178	187
EX8		—	—	318	386	436	474	500
EX4	0	—	—	—	6	7	8	9
EX5		—	—	—	17	21	24	26
EX6		—	—	—	41	51	58	63
EX7		—	—	—	114	140	159	172
EX8		—	—	—	303	373	423	458
EX4	-10	—	—	—	—	5	7	8
EX5		—	—	—	—	17	20	23
EX6		—	—	—	—	40	49	55
EX7		—	—	—	—	109	134	152
EX8		—	—	—	—	290	359	405
EX4	-20	—	—	—	—	3	5	6
EX5		—	—	—	—	19	16	20
EX6		—	—	—	—	22	38	47
EX7		—	—	—	—	61	104	129
EX8		—	—	—	—	163	278	344
EX4	-30	—	—	—	—	—	3	5
EX5		—	—	—	—	—	8	15
EX6		—	—	—	—	—	19	35
EX7		—	—	—	—	—	53	96
EX8		—	—	—	—	—	142	257

EX5-8 nominal capacities (tons) - as condensing pressure regulator and liquid duty

Valve type	R-407C	R-22	R-134A	R-404A
EX5	5	6	5	4
EX6	12	13	12	9
EX7	44	46	43	31
EX8	133	140	131	93

The nominal capacity is based on the following conditions:

Refrigerant	Evaporating temperature	Condensing temperature	Subcooling	Pressure drop
R-22, R-134a, R-404A	+40°F	+100°F	2°F	5 Psid
R-407C	+40°F dew point	+100°F bubble	2°F	5 Psid

Note 1: Bi-flow versions are not released for use below -40°F.

Note 2: EX6, EX7 and EX8 must be installed with motor downward in suction line applications. This insures the valve life expectancy.

Multiply above nominal capacities by following factors to obtain capacities at different pressure drops:

ΔP, Psid	2.0	3.0	5.0
Correction factor	0.65	0.76	1.00

R-22 extended capacities (tons) - EX5-8 series, condensing pressure regulator and liquid duty

Valve type	Condensing temperature °f	Evaporating temperature °f									
		50	40	30	20	10	0	-10	-20	-30	-40
EX5	140	4	4	4	4	4	4	4	4	4	4
EX6		10	10	10	10	10	9	9	9	9	9
EX7		36	36	35	35	34	33	33	32	31	31
EX8		111	109	107	105	104	102	100	98	96	94
EX5	130	5	5	5	4	4	4	4	4	4	4
EX6		11	11	11	10	10	10	10	10	10	9
EX7		39	38	38	37	37	36	35	35	34	33
EX8		118	116	115	113	111	109	107	105	103	101
EX5	120	5	5	5	5	5	5	5	5	4	4
EX6		12	12	11	11	11	11	11	10	10	10
EX7		42	41	41	40	39	39	38	37	37	36
EX8		126	125	123	121	119	117	115	113	111	109
EX5	110	5	5	5	5	5	5	5	5	5	5
EX6		12	12	12	12	12	12	11	11	11	11
EX7		44	43	43	42	42	41	40	40	39	38
EX8		133	132	130	128	126	124	122	120	118	116
EX5	100	6	6	6	5	5	5	5	5	5	5
EX6		13	13	13	13	12	12	12	12	12	11
EX7		47	46	46	45	44	44	43	42	41	41
EX8		142	140	138	136	134	132	130	128	126	124

R-134A extended capacities (tons) - EX5-8 series, condensing pressure regulator and liquid duty

Valve type	Condensing temperature °f	Evaporating temperature °f			
		50	40	30	20
EX5	140	4	4	4	4
EX6		9	9	9	8
EX7		33	32	31	30
EX8		100	98	95	92
EX5	130	4	4	4	4
EX6		10	10	9	9
EX7		36	35	34	33
EX8		108	105	102	99
EX5	120	5	5	4	4
EX6		11	11	10	10
EX7		39	38	37	36
EX8		117	115	112	108
EX5	110	5	5	5	5
EX6		12	11	11	11
EX7		41	40	39	38
EX8		125	122	119	116
EX5	100	5	5	5	5
EX6		12	12	12	12
EX7		44	43	42	41
EX8		134	131	128	125

R-407C extended capacities (tons) - EX5-8 series, condensing pressure regulator and liquid duty

Valve type	Condensing temperature Dew point °f	Evaporating temperature °f			
		50	40	30	20
EX5	140	4	4	4	4
EX6		9	9	9	8
EX7		32	32	31	30
EX8		98	96	94	91
EX5	130	4	4	4	4
EX6		10	10	9	9
EX7		35	34	34	33
EX8		106	105	102	100
EX5	120	5	5	4	4
EX6		11	11	10	10
EX7		38	38	37	36
EX8		117	115	112	110
EX5	110	5	5	5	5
EX6		12	11	11	11
EX7		41	40	40	39
EX8		125	123	120	118
EX5	100	5	5	5	5
EX6		12	12	12	12
EX7		44	44	43	42
EX8		135	133	130	128

*EX4-8 nominal capacities (tons) - as hot gas bypass regulator*

Valve type	R-22 / R-407C	R-134A	R-404A / R-507
EX4	1.4	1.0	1.3
EX5	4.5	3.1	4.3
EX6	10.5	7.3	10.1
EX7	37.3	26.0	35.7
EX8	113.0	79.0	108.5

*The nominal capacity is based on the following conditions:*

Refrigerant	Evaporating temperature	Condensing temperature	Subcooling
R-22, R-134a, R-404A, R-507	+40°F	+100°F	2°F
R-407C	+40°F bubble point	+100°F dew point	2°F

**Note 1:** Bi-flow versions are not released for hot gas bypass applications.

**Note 2:** EX4, EX5, EX6, EX7 and EX8 must be installed with motor downward in hot gas line applications.

*Extended capacities (tons) - EX4-8 series*

Valve type	Liquid / condensing temperature <sup>°f</sup>	R-22 / R-407C	R-134A	R-404A / R-507
EX4	140 Bubble point for all refrigerants (147 dew point for R-407C)	2	1	2
EX5		7	5	6
EX6		15	11	13
EX7		54	38	46
EX8		165	117	139
EX4	130 bubble point for all refrigerants (138 dew point for R-407C)	2	1	2
EX5		6	4	5
EX6		14	10	12
EX7		49	35	44
EX8		150	106	132
EX4	120 bubble point for all refrigerants (128 dew point for R-407C)	2	1	2
EX5		6	4	5
EX6		13	9	12
EX7		45	32	41
EX8		138	97	126
EX4	110 bubble point for all refrigerants (119 dew point for R-407C)	2	1	1
EX5		5	3	5
EX6		12	8	11
EX7		41	29	38
EX8		124	87	117

*EX6-8 nominal capacities (tons) - as for hot gas flow such as heat reclaim application*

Valve type	R-22 / R-407C	R-404A / R-507
EX6	3.1	2.8
EX7	11.1	10.2
EX8	33.8	30.7

*The nominal capacity is based on the following conditions:*

Refrigerant	Evaporating temperature	Condensing temperature	Subcooling	Pressure drop	Isentropic efficiency
R-22, R-404A, R-507	+40°F	+100°F	2°F	2 psid	80%
R-407C	+40°F bubble point	+100°F dew point	2°F	2 psid	80%

**Note:** Bi-flow versions are not released for hot gas bypass applications.  
**Note:** EX6, EX7 and EX8 must be installed with motor downward in suction line applications. This insures the valve life expectancy.

*R-22 / R-407C extended capacities (tons) - EX6-8 eeries, as for hot gas flow such as heat reclaim application*

Valve type	Condensing temperature °f	Pressure drop PSI	Evaporating temperature °f												
			60	50	40	30	20	10	0	-10	-20	-30	-40	-50	
EX6	140	1.5	1.6	1.5	1.5	1.5	1.4	1.4	1.3	1.3	1.2	1.2	1.2	1.1	
EX7			5.6	5.5	5.3	5.2	5.0	4.9	4.7	4.6	4.4	4.3	4.1	4.0	
EX8			17.0	16.6	16.2	15.7	15.3	14.8	14.4	13.9	13.4	13.0	12.5	12.0	
EX6		7.0	3.4	3.3	3.3	3.2	3.1	3.0	2.9	2.8	2.7	2.6	2.5	2.4	
EX7			12.2	11.9	11.6	11.3	10.9	10.6	10.3	10.0	9.6	9.3	9.0	8.6	
EX8			37.0	36.1	35.2	34.2	33.3	32.3	31.3	30.3	29.3	28.2	27.2	26.2	
EX6		14.0	4.8	4.7	4.5	4.4	4.3	4.2	4.0	3.9	3.8	3.7	3.5	3.4	
EX7			17.3	16.9	16.4	16.0	15.6	15.1	14.6	14.2	13.7	13.2	12.7	12.3	
EX8			52.5	51.3	49.9	48.6	47.3	45.9	44.5	43.0	41.6	40.2	38.7	37.3	
EX6		120	1.5	1.5	1.5	1.5	1.4	1.4	1.4	1.3	1.3	1.2	1.2	1.2	1.1
EX7				5.5	5.3	5.2	5.1	4.9	4.8	4.7	4.5	4.4	4.3	4.1	4.0
EX8				16.6	16.2	15.8	15.4	15.0	14.6	14.2	13.8	13.4	12.9	12.5	12.1
EX6	7.0		3.3	3.3	3.2	3.1	3.0	2.9	2.9	2.8	2.7	2.6	2.5	2.4	
EX7			11.8	11.6	11.3	11.0	10.7	10.4	10.1	9.9	9.6	9.3	8.9	8.6	
EX8			35.9	35.1	34.3	33.5	32.6	31.7	30.8	29.9	29.0	28.1	27.2	26.2	
EX6	14.0		4.6	4.5	4.4	4.3	4.2	4.1	4.0	3.9	3.7	3.6	3.5	3.4	
EX7			16.8	16.4	16.0	15.6	15.2	14.8	14.4	14.0	13.5	13.1	12.7	12.3	
EX8			50.9	49.7	48.6	47.4	46.2	44.9	43.7	42.4	41.1	39.8	38.5	37.2	
EX6	100		1.5	1.5	1.4	1.4	1.4	1.3	1.3	1.3	1.2	1.2	1.2	1.1	1.1
EX7				5.2	5.1	5.0	4.9	4.7	4.6	4.5	4.4	4.3	4.1	4.0	3.9
EX8				15.8	15.4	15.1	14.7	14.4	14.0	13.7	13.3	12.9	12.5	12.2	11.8
EX6		7.0	3.2	3.1	3.0	3.0	2.9	2.8	2.7	2.7	2.6	2.5	2.4	2.4	
EX7			11.2	11.0	10.7	10.5	10.2	10.0	9.7	9.5	9.2	8.9	8.7	8.4	
EX8			34.1	33.4	32.6	31.9	31.1	30.4	29.6	28.8	28.0	27.1	26.3	25.5	
EX6		14.0	4.4	4.3	4.2	4.1	4.0	3.9	3.8	3.7	3.6	3.5	3.4	3.3	
EX7			15.8	15.5	15.2	14.8	14.5	14.1	13.7	13.4	13.0	12.6	12.2	11.8	
EX8			48.0	47.0	46.0	45.0	43.9	42.8	41.7	40.6	39.5	38.3	37.2	36.0	
EX6		80	1.5	1.4	1.3	1.3	1.3	1.2	1.2	1.2	1.2	1.1	1.1	1.1	1.0
EX7				4.8	4.7	4.6	4.5	4.4	4.3	4.2	4.1	4.0	3.9	3.8	3.7
EX8				14.7	14.4	14.1	13.8	13.5	13.2	12.8	12.5	12.2	11.9	11.5	11.2
EX6	7.0		2.9	2.9	2.8	2.8	2.7	2.6	2.6	2.5	2.4	2.4	2.3	2.2	
EX7			10.4	10.2	10.0	9.8	9.6	9.3	9.1	8.9	8.6	8.4	8.2	7.9	
EX8			31.6	31.0	30.4	29.7	29.0	28.4	27.7	27.0	26.3	25.6	24.8	24.1	
EX6	14.0		4.0	4.0	3.9	3.8	3.7	3.6	3.5	3.4	3.4	3.3	3.2	3.1	
EX7			14.6	14.3	14.0	13.7	13.4	13.1	12.8	12.5	12.1	11.8	11.5	11.1	
EX8			44.3	43.4	42.6	41.7	40.7	39.8	38.8	37.9	36.9	35.9	34.8	33.8	

R-404A / R-507 extended capacities (tons) - EX6-8 series, hot gas flow such a heat reclaim applications

Valve type	Condensing temperature °f	Pressure drop PSI	Evaporating temperature °f											
			60	50	40	30	20	10	0	-10	-20	-30	-40	-50
EX6	140	1.5	1.2	1.1	1.1	1.0	1.0	0.9	0.9	0.8	0.8	0.7	0.7	0.6
EX7			4.2	4.1	3.9	3.7	3.5	3.3	3.2	3.0	2.8	2.6	2.4	2.2
EX8			12.8	12.3	11.8	11.3	10.7	10.1	9.6	9.0	8.4	7.8	7.2	6.6
EX6		7	2.6	2.5	2.4	2.3	2.2	2.0	1.9	1.8	1.7	1.6	1.4	1.3
EX7			9.2	8.8	8.4	8.1	7.7	7.3	6.8	6.4	6.0	5.6	5.2	4.7
EX8			27.8	26.7	25.6	24.5	23.3	22.0	20.8	19.5	18.2	16.9	15.6	14.4
EX6		14	3.6	3.4	3.3	3.2	3.0	2.8	2.7	2.5	2.4	2.2	2.0	1.9
EX7			13.0	12.5	12.0	11.4	10.9	10.3	9.7	9.1	8.5	7.9	7.3	6.7
EX8			39.4	37.9	36.3	34.7	33.0	31.3	29.5	27.7	25.9	24.1	22.2	20.4
EX6	120	1.5	1.3	1.3	1.2	1.2	1.1	1.1	1.0	1.0	0.9	0.9	0.8	0.8
EX7			4.6	4.5	4.3	4.2	4.0	3.8	3.7	3.5	3.3	3.2	3.0	2.8
EX8			14.0	13.6	13.1	12.7	12.2	11.7	11.2	10.7	10.1	9.6	9.1	8.5
EX6		7	2.8	2.7	2.6	2.5	2.4	2.3	2.2	2.1	2.0	1.9	1.8	1.7
EX7			10.0	9.7	9.4	9.0	8.7	8.3	8.0	7.6	7.2	6.9	6.5	6.1
EX8			30.4	29.5	28.5	27.5	26.4	25.4	24.3	23.1	22.0	20.9	19.7	18.6
EX6		14	3.9	3.8	3.7	3.5	3.4	3.3	3.1	3.0	2.8	2.7	2.5	2.4
EX7			14.1	13.7	13.3	12.8	12.3	11.8	11.3	10.8	10.3	9.7	9.2	8.7
EX8			43.0	41.7	40.3	38.9	37.4	35.9	34.4	32.8	31.2	29.6	28.0	26.3
EX6	100	1.5	1.3	1.3	1.2	1.2	1.2	1.1	1.1	1.1	1.0	1.0	0.9	0.9
EX7			4.7	4.6	4.4	4.3	4.2	4.0	3.9	3.7	3.6	3.4	3.3	3.1
EX8			14.2	13.9	13.5	13.1	12.7	12.2	11.8	11.4	10.9	10.4	10.0	9.5
EX6		7	2.9	2.8	2.7	2.6	2.5	2.5	2.4	2.3	2.2	2.1	2.0	1.9
EX7			10.1	9.9	9.6	9.3	9.0	8.7	8.4	8.1	7.8	7.4	7.1	6.8
EX8			30.8	30.0	29.2	28.3	27.4	26.5	25.5	24.6	23.6	22.6	21.6	20.6
EX6		14	4.0	3.9	3.7	3.6	3.5	3.4	3.3	3.2	3.0	2.9	2.8	2.6
EX7			14.3	13.9	13.5	13.1	12.7	12.3	11.9	11.4	11.0	10.5	10.0	9.6
EX8			43.5	42.3	41.2	39.9	38.7	37.4	36.1	34.7	33.3	31.9	30.5	29.1
EX6	80	1.5	1.3	1.3	1.2	1.2	1.2	1.1	1.1	1.1	1.0	1.0	0.9	0.9
EX7			4.6	4.5	4.4	4.2	4.1	4.0	3.9	3.8	3.6	3.5	3.4	3.2
EX8			13.9	13.6	13.3	12.9	12.6	12.2	11.8	11.4	11.0	10.6	10.2	9.8
EX6		7	2.8	2.7	2.6	2.6	2.5	2.4	2.4	2.3	2.2	2.1	2.0	2.0
EX7			9.9	9.6	9.4	9.2	8.9	8.7	8.4	8.1	7.8	7.6	7.3	7.0
EX8			30.0	29.3	28.6	27.8	27.1	26.3	25.5	24.7	23.8	22.9	22.1	21.2
EX6		14	3.8	3.7	3.7	3.6	3.5	3.4	3.3	3.2	3.0	2.9	2.8	2.7
EX7			13.9	13.5	13.2	12.9	12.5	12.2	11.8	11.4	11.0	10.6	10.2	9.8
EX8			42.1	41.1	40.1	39.1	38.0	36.9	35.8	34.7	33.5	32.3	31.1	29.8

EX6-8 nominal capacities (tons) - as suction pressure regulator (evaporator or crankcase)

Valve type	R-407C	R-22	R-134a	R-404A
EX6	1.1	1.1	0.9	1.0
EX7	3.8	4.0	3.0	3.5
EX8	11.5	12.2	9.2	10.5

The nominal capacity is based on the following conditions:

Refrigerant	Evaporating temperature	Condensing temperature	Subcooling	Pressure drop
R-22, R-134a, R-404A	+40°F	+100°F	2°F	2 psid
R-407C	+40°F bubble point	+100°F dew point	2°F	2 psid

Note 1: Bi-flow versions are not released for use below -40°F.

Note 2: EX6, EX7 and EX8 must be installed with motor downward in suction line applications. This insures the valve life expectancy.

Multiply above nominal capacities by following factors to obtain capacities at different pressure drops:

ΔP, psid	1.5	2.0	3.0	4.5
CORRECTION FACTOR	0.82	1.00	1.15	1.41

Example: EX6 provides 1 ton at 2.0 psid pressure drop with R-404A: 4 psi pressure drop.

R-404A / R-507 extended capacities (tons) - EX6-8 series, suction pressure regulator duty

Valve type	Condensing temperature °f	Evaporating temperature °f									
		50	40	30	20	10	0	-10	-20	-30	-40
EX6	140	1	1	1	0	0	0	0	0	0	0
EX7		3	2	2	2	2	1	1	1	1	
EX8		8	7	6	5	5	4	3	3	2	2
EX6	130	1	1	1	1	1	0	0	0	0	0
EX7		3	3	2	2	2	2	1	1	1	1
EX8		9	8	7	6	5	5	4	3	3	2
EX6	120	1	1	1	1	1	0	0	0	0	0
EX7		3	3	3	2	2	2	1	1	1	1
EX8		10	9	8	7	6	5	4	4	3	3
EX6	110	1	1	1	1	1	1	0	0	0	0
EX7		4	3	3	2	2	2	2	1	1	1
EX8		11	10	9	8	7	6	5	4	4	3
EX6	100	1	1	1	1	1	1	1	0	0	0
EX7		4	3	3	3	2	2	2	2	1	1
EX8		12	11	9	8	7	6	5	5	4	3

R-404A / R-507 extended capacities (tons) - EX6-8 series, hot gas flow such a heat reclaim applications

Valve type	Condensing temperature °f	Pressure drop PSI	Evaporating temperature °f											
			60	50	40	30	20	10	0	-10	-20	-30	-40	-50
EX6	140	1.5	1.2	1.1	1.1	1.0	1.0	0.9	0.9	0.8	0.8	0.7	0.7	0.6
EX7			4.2	4.1	3.9	3.7	3.5	3.3	3.2	3.0	2.8	2.6	2.4	2.2
EX8			12.8	12.3	11.8	11.3	10.7	10.1	9.6	9.0	8.4	7.8	7.2	6.6
EX6		7	2.6	2.5	2.4	2.3	2.2	2.0	1.9	1.8	1.7	1.6	1.4	1.3
EX7			9.2	8.8	8.4	8.1	7.7	7.3	6.8	6.4	6.0	5.6	5.2	4.7
EX8			27.8	26.7	25.6	24.5	23.3	22.0	20.8	19.5	18.2	16.9	15.6	14.4
EX6		14	3.6	3.4	3.3	3.2	3.0	2.8	2.7	2.5	2.4	2.2	2.0	1.9
EX7			13.0	12.5	12.0	11.4	10.9	10.3	9.7	9.1	8.5	7.9	7.3	6.7
EX8			39.4	37.9	36.3	34.7	33.0	31.3	29.5	27.7	25.9	24.1	22.2	20.4
EX6	120	1.5	1.3	1.3	1.2	1.2	1.1	1.1	1.0	1.0	0.9	0.9	0.8	0.8
EX7			4.6	4.5	4.3	4.2	4.0	3.8	3.7	3.5	3.3	3.2	3.0	2.8
EX8			14.0	13.6	13.1	12.7	12.2	11.7	11.2	10.7	10.1	9.6	9.1	8.5
EX6		7	2.8	2.7	2.6	2.5	2.4	2.3	2.2	2.1	2.0	1.9	1.8	1.7
EX7			10.0	9.7	9.4	9.0	8.7	8.3	8.0	7.6	7.2	6.9	6.5	6.1
EX8			30.4	29.5	28.5	27.5	26.4	25.4	24.3	23.1	22.0	20.9	19.7	18.6
EX6		14	3.9	3.8	3.7	3.5	3.4	3.3	3.1	3.0	2.8	2.7	2.5	2.4
EX7			14.1	13.7	13.3	12.8	12.3	11.8	11.3	10.8	10.3	9.7	9.2	8.7
EX8			43.0	41.7	40.3	38.9	37.4	35.9	34.4	32.8	31.2	29.6	28.0	26.3
EX6	100	1.5	1.3	1.3	1.2	1.2	1.2	1.1	1.1	1.1	1.0	1.0	0.9	0.9
EX7			4.7	4.6	4.4	4.3	4.2	4.0	3.9	3.7	3.6	3.4	3.3	3.1
EX8			14.2	13.9	13.5	13.1	12.7	12.2	11.8	11.4	10.9	10.4	10.0	9.5
EX6		7	2.9	2.8	2.7	2.6	2.5	2.5	2.4	2.3	2.2	2.1	2.0	1.9
EX7			10.1	9.9	9.6	9.3	9.0	8.7	8.4	8.1	7.8	7.4	7.1	6.8
EX8			30.8	30.0	29.2	28.3	27.4	26.5	25.5	24.6	23.6	22.6	21.6	20.6
EX6		14	4.0	3.9	3.7	3.6	3.5	3.4	3.3	3.2	3.0	2.9	2.8	2.6
EX7			14.3	13.9	13.5	13.1	12.7	12.3	11.9	11.4	11.0	10.5	10.0	9.6
EX8			43.5	42.3	41.2	39.9	38.7	37.4	36.1	34.7	33.3	31.9	30.5	29.1
EX6	80	1.5	1.3	1.3	1.2	1.2	1.2	1.1	1.1	1.1	1.0	1.0	0.9	0.9
EX7			4.6	4.5	4.4	4.2	4.1	4.0	3.9	3.8	3.6	3.5	3.4	3.2
EX8			13.9	13.6	13.3	12.9	12.6	12.2	11.8	11.4	11.0	10.6	10.2	9.8
EX6		7	2.8	2.7	2.6	2.6	2.5	2.4	2.4	2.3	2.2	2.1	2.0	2.0
EX7			9.9	9.6	9.4	9.2	8.9	8.7	8.4	8.1	7.8	7.6	7.3	7.0
EX8			30.0	29.3	28.6	27.8	27.1	26.3	25.5	24.7	23.8	22.9	22.1	21.2
EX6		14	3.8	3.7	3.7	3.6	3.5	3.4	3.3	3.2	3.0	2.9	2.8	2.7
EX7			13.9	13.5	13.2	12.9	12.5	12.2	11.8	11.4	11.0	10.6	10.2	9.8
EX8			42.1	41.1	40.1	39.1	38.0	36.9	35.8	34.7	33.5	32.3	31.1	29.8

EX6-8 nominal capacities (tons) - as suction pressure regulator (evaporator or crankcase)

Valve type	R-407C	R-22	R-134a	R-404A
EX6	1.1	1.1	0.9	1.0
EX7	3.8	4.0	3.0	3.5
EX8	11.5	12.2	9.2	10.5

The nominal capacity is based on the following conditions:

Refrigerant	Evaporating temperature	Condensing temperature	Subcooling	Pressure drop
R-22, R-134A, R-404A	+40°F	+100°F	2°F	2 psid
R-407C	+40°F bubble point	+100°F dew point	2°F	2 psid

Note 1: Bi-flow versions are not released for use below -40°F.

Note 2: EX6, EX7 and EX8 must be installed with motor downward in suction line applications. This insures the valve life expectancy.

Multiply above nominal capacities by following factors to obtain capacities at different pressure drops:

ΔP, psid	1.5	2.0	3.0	4.5
CORRECTION FACTOR	0.82	1.00	1.15	1.41

Example: EX6 provides 1 ton at 2.0 psid pressure drop with R-404A: 4 psi pressure drop.

R-404A / R-507 extended capacities (tons) - EX6-8 series, suction pressure regulator duty

Valve type	Condensing temperature °f	Evaporating temperature °f									
		50	40	30	20	10	0	-10	-20	-30	-40
EX6	140	1	1	1	0	0	0	0	0	0	0
EX7		3	2	2	2	2	1	1	1	1	
EX8		8	7	6	5	5	4	3	3	2	2
EX6	130	1	1	1	1	1	0	0	0	0	0
EX7		3	3	2	2	2	2	1	1	1	1
EX8		9	8	7	6	5	5	4	3	3	2
EX6	120	1	1	1	1	1	0	0	0	0	0
EX7		3	3	3	2	2	2	1	1	1	1
EX8		10	9	8	7	6	5	4	4	3	3
EX6	110	1	1	1	1	1	1	0	0	0	0
EX7		4	3	3	2	2	2	2	1	1	1
EX8		11	10	9	8	7	6	5	4	4	3
EX6	100	1	1	1	1	1	1	1	0	0	0
EX7		4	3	3	3	2	2	2	2	1	1
EX8		12	11	9	8	7	6	5	5	4	3

# Refrigerant solenoid valves quick selection guide

## Uni-flow solenoids

Tonnage		Operation		Two types		Design	Port size	Valve series
R-410a	R-404a	Normally closed	Normally open	Direct acting	Pilot operated			
—	0.9	√		√		Piston	1/8"	100RB 2
3.4	2.3	√			√	Piston	1/8"	200RB 2
4.5	3.1	√			√	Piston	3/16"	200RB 3
7.5	5.1	√			√	Piston	1/4"	200RB 4
7.7	5.3	√			√	Piston	5/16"	200RB 5
8.9	6.1	√			√	Piston	3/8"	200RB 6
15.7	11.1	√			√	Piston	7/16"	200RB 7
14.6	10.3	√			√	Diaphragm	1/2"	250RA 8
28.5	20.1	√			√	Diaphragm	9/16"	250RA 9
32.6	23.0	√			√	Diaphragm	3/4"	250RA 12
54.2	38.3	√			√	Diaphragm	1"	250RA 16
89.1	65.7	√			√	Diaphragm	1-1/4"	250RA 20
3.4	2.3		√		√	Piston	1/8"	500RB 2
4.5	3.1		√		√	Piston	3/16"	500RB 3
7.5	5.1		√		√	Piston	1/4"	500RB 4
7.7	5.3		√		√	Piston	5/16"	500RB 5
8.9	6.1		√		√	Piston	3/8"	500RB 6
15.7	11.1		√		√	Piston	7/16"	500RB 7
14.6	10.3		√		√	Diaphragm	1/2"	540RA 8
28.5	20.1		√		√	Diaphragm	9/16"	540RA 9
32.6	23.0		√		√	Diaphragm	3/4"	540RA 12
54.2	38.3		√		√	Diaphragm	1"	540RA 16
89.1	65.7		√		√	Diaphragm	1-1/4"	540RA 20

## Bi-flow solenoids

Tonnage		Operation		Two types		Design	Port size	Valve series
R-410a		Normally closed	Normally open	Direct acting	Pilot operated			
4.5		√			√	Piston	3/16"	200RB 3 BF
7.5		√			√	Piston	1/4"	200RB 4 BF
7.7		√			√	Piston	5/16"	200RB 5 BF
8.9		√			√	Piston	3/8"	200RB 6 BF



100RB 2S3VLC

# 100RB Series Refrigerant Solenoid Valves

The 100RB is a direct-acting, 2-way, normally closed valve used for liquid, discharge or suction gas refrigerant service.

## Features

- Single coil family fits all valve sizes
- Extended ends for easy installation (standard)
- SAE or ODF connection sizes in 1/4" and 3/8" or 1/4" NPTF
- Field serviceable parts available
- Compatible with all common A1, A2L, and A3 class refrigerants (refer to the capacity tables)

## Specifications

Maximum fluid temperature.....	250°F (121°C)
Maximum working pressure.....	500 psig (35 bar)
Maximum operating pressure differential.....	300 psig (21 bar)
UL/CUL file number.....	MP604
Canadian CRN.....	OC21506.513467890YTN

Model number nomenclature - Example: 100RB 2F2VLC

Valve series	Port size	Connection type	Connection size	*Coil	Sequential identifier	Customer special	Pack type
100RB	2	F	2	VLC			
Direct-Acting Refrigerant Solenoid Valves	In 1/16"	F = SAE S = ODF Extended Ends P = NPTF	In 1/8" Increments	VLC = Valve Less Coil  For Valves with Coil See Coil Nomenclature on Coil Catalog Page	Blank Thru -99	G = Customer Special  (Omit for Standard)	B1 = Bulk Pack  (Omit for Individual Pack)

\* Valves in catalog are shipped without solenoid coils (VLC = Valve Less Coil). See coil pages for coil selection and a complete list of voltage options.

## 100RB Series Refrigerant Solenoid Valves

Port size (in)	Connection size & type	Nominal liquid capacity -tons (kw)							Model number	Item number
		R-22	R-134a	R-290	R-404a / R-507	R-407c	R-448a / R-449a	R-450a / R-513a		
1/8	1/4" SAE	1.3 (4.5)	1.0 (3.4)	1.3 (4.5)	0.9 (3.0)	1.2 (4.3)	1.3 (4.5)	0.9 (3.1)	100RB 2F2VLC	047500
	1/4" NPTF								100RB 2P2VLC	047502
	1/4" ODF								100RB 2S2VLC	047503
	3/8" SAE								100RB 2F3VLC	047501
	3/8" ODF								100RB 2S3VLC	047504
	1/2" ODF								100RB 2S4VLC	047505

NOTE: Capacities based on 100°F liquid and 40°F saturated evaporator per ARI standard 760-87.



Detailed product drawings

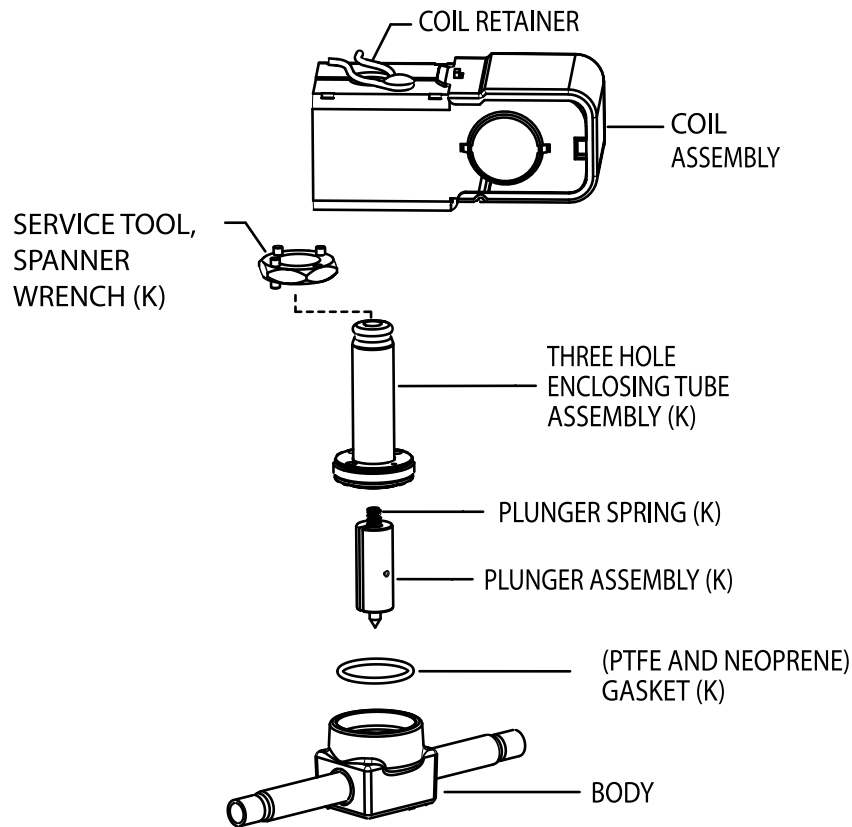
Extended capacity tables



Exploded view & parts kit data

100RB series part kits

Description	Model number	Item number
Valve Repair Kit (K)	KS-30112	049191
Universal (2/3 hole) spanner wrench	X-11981-1	027451
Parts Kit (Contains 12 pieces each of PTFE and neoprene O-rings)	KG-10041	054812
Magnetic Solenoid Tool opens a normally closed solenoid valve in the de-energized state, incorporates a spanner wrench for easy disassembly of solenoid valve series 100RB, 200RB, 240RA and provides an orifice to manually adjust opening stem.	Solenoid tool	066019



Valve repair kit  
 (K) indicates part is  
 supplied in valve repair kit.



200RB 5T5M VLC

# 200RB Series Refrigerant Solenoid Valves

The 200RB is a pilot-operated, 2-way, normally closed valve used for liquid, discharge, or suction gas refrigerant service.

## Features

- Single coil family fits all valve sizes
- Extended ends for easy installation (standard)
- Available in 6 port sizes
- Optional manual stem or mounting stud
- Bi-Directional operation either factory assembled or convert with kit KS-30293 (except 200RB 7 & 9)
- Field serviceable parts available
- Compatible with all common A1, A2L, and A3 class refrigerants (refer to the capacity tables)
- 200RB2 to 200RB6 uniflow models comply with the A2L Safety Shut-off Valve standards of UL 60335-2-40 and 60335-2-89

## Specifications

Maximum fluid temperature.....250°F (121°C)  
 Maximum working pressure .....680 psig (47 bar)  
 Minimum operating pressure drop .....2 psi (0.15 bar)  
 \*Maximum operating pressure differential.....300 psig (21 bar)  
 UL/CUL file number.....MP604  
 Canadian CRN.....0C21506.513467890YTN  
 \* MOPD based on AC applications. Consult application engineer for DC applications.

Model number nomenclature - Example: 200RB 3T3BFVLC

Valve series	Design series	Port size	Connection type	Connection size	Valve configuration	*Coil	Sequential identifier	Customer special	Pack type
200R	B	3	T	3	BF	VLC			
Pilot-Operated Normally Closed Refrigerant Solenoid Valves	Piston Design	In 1/16"	F = SAE S = ODF Short T = ODF Extended Ends	In 1/8"	BF = Bi-Directional (Heat Pump) M = Manual Opening Stem T = Mounting Stud  (Omit for Std. Valve)	VLC = Valve Less Coil For Valves with Coil See Coil Nomenclature on Coil Catalog Page	Blank Thru -99	G = Customer Special  (Omit for Std.)	B1 = Bulk Pack  (Omit for Individual Pack)

\* Valves in catalog are shipped without solenoid coils (VLC = Valve Less Coil). See coil pages for coil selection and a complete list of voltage options.

## 200RB Series Refrigerant Solenoid Valves

Valve config.	Port size (in)	Conn. size & type (in)	Extd. ends	Nominal liquid capacity - tons (kw)									Model number	Item number
				R-22	R-134a	R-290	R-404a / R-507	R-407c	R-410a	R-448a / R-449a	R-450a / R-513a	R-744		
Standard	1/8	1/4 SAE	—	3.6 (12.7)	2.7 (9.6)	3.8 (13.4)	2.3 (8.2)	3.4 (11.9)	3.4 (11.9)	3.6 (12.7)	2.5 (8.7)	8.2 (28.7)	200RB 2F2VLC	053104
		1/4 ODF	Yes										200RB 2T2VLC	053105
		3/8 SAE	—										200RB 2F3VLC	062611
		3/8 ODF	Yes										200RB 2T3VLC	053106
	3/16	1/4 ODF	Yes	4.8 (16.9)	3.6 (12.7)	5.0 (17.6)	3.1 (10.9)	4.5 (15.9)	4.5 (15.8)	4.8 (17.0)	3.3 (11.6)	10.9 (38.2)	200RB 3T2VLC	049608
		3/8 SAE	—										200RB 3F3VLC	052726
		3/8 ODF	Yes										200RB 3T3VLC	049609
		1/2 SAE	—										200RB 3F4VLC	052727
	1/4	1/2 ODF	Yes	8.0 (28.0)	6.0 (21.1)	8.3 (29.2)	5.1 (18.0)	7.5 (26.3)	7.5 (26.4)	8.0 (28.1)	5.5 (19.3)	18.0 (63.3)	200RB 3T4VLC	049692
		3/8 SAE	—										200RB 4F3VLC	047506
		3/8 ODF X 1/2 ODM	—										200RB 4S3VLC	047511
		3/8 ODF	Yes										200RB 4T3VLC	047517
		1/2 ODF X 5/8 ODM	—										200RB 4S4VLC	047516
		1/2 ODF	Yes										200RB 4T4VLC	047518
		1/2 ODF	Yes										200RB 4T5VLC	058950
		5/8 ODF	Yes											

200RB Series Refrigerant Solenoid Valves (continued)

Valve config.	Port size (in)	Conn. size & type (in)	Extd. ends	Nominal liquid capacity - tons (kw)									Model number	Item number
				R-22	R-134a	R-290	R-404a / R-507	R-407c	R-410a	R-448a / R-449a	R-450a / R-513a	R-744		
Standard	5/16	3/8 ODF	Yes	8.2 (28.9)	6.2 (21.8)	8.6 (30.1)	5.3 (18.6)	7.7 (27.2)	7.7 (26.4)	8.3 (29.0)	5.7 (19.9)	18.7 (65.5)	200RB 5T3VLC	061227
	5/16	1/2 SAE	—	8.2 (28.9)	6.2 (21.8)	8.6 (30.1)	5.3 (18.6)	7.7 (27.2)	7.7 (26.4)	8.3 (29.0)	5.7 (19.9)	18.7 (65.5)	200RB 5F4VLC	047519
	5/16	1/2 ODF X 5/8 ODM	—	8.2 (28.9)	6.2 (21.8)	8.6 (30.1)	5.3 (18.6)	7.7 (27.2)	7.7 (26.4)	8.3 (29.0)	5.7 (19.9)	18.7 (65.5)	200RB 5S4VLC	047524
	5/16	1/2 ODF	Yes	8.2 (28.9)	6.2 (21.8)	8.6 (30.1)	5.3 (18.6)	7.7 (27.2)	7.7 (26.4)	8.3 (29.0)	5.7 (19.9)	18.7 (65.5)	200RB 5T4VLC	057206
	5/16	5/8 SAE	—	8.2 (28.9)	6.2 (21.8)	8.6 (30.1)	5.3 (18.6)	7.7 (27.2)	7.7 (26.4)	8.3 (29.0)	5.7 (19.9)	18.7 (65.5)	200RB 5F5VLC	059729
	5/16	5/8 ODF	—	8.2 (28.9)	6.2 (21.8)	8.6 (30.1)	5.3 (18.6)	7.7 (27.2)	7.7 (26.4)	8.3 (29.0)	5.7 (19.9)	18.7 (65.5)	200RB 5S5VLC	049201
	5/16	5/8 ODF	Yes	8.2 (28.9)	6.2 (21.8)	8.6 (30.1)	5.3 (18.6)	7.7 (27.2)	7.7 (26.4)	8.3 (29.0)	5.7 (19.9)	18.7 (65.5)	200RB 5T5VLC	059730
	3/8	1/2 ODF	Yes	9.5 (33.3)	7.2 (25.2)	9.9 (34.7)	6.1 (21.5)	8.9 (31.4)	8.9 (31.3)	9.5 (33.5)	6.5 (23.0)	21.5 (75.6)	200RB 6T4VLC	047544
	3/8	5/8 SAE	—	9.5 (33.3)	7.2 (25.2)	9.9 (34.7)	6.1 (21.5)	8.9 (31.4)	8.9 (31.3)	9.5 (33.5)	6.5 (23.0)	21.5 (75.6)	200RB 6F5VLC	059732
	3/8	5/8 ODF	—	9.5 (33.3)	7.2 (25.2)	9.9 (34.7)	6.1 (21.5)	8.9 (31.4)	8.9 (31.3)	9.5 (33.5)	6.5 (23.0)	21.5 (75.6)	200RB 6S5VLC	047540
	3/8	5/8 ODF	Yes	9.5 (33.3)	7.2 (25.2)	9.9 (34.7)	6.1 (21.5)	8.9 (31.4)	8.9 (31.3)	9.5 (33.5)	6.5 (23.0)	21.5 (75.6)	200RB 6T5VLC	056766
	7/16	5/8 ODF X 7/8 ODM	—	17.0 (59.8)	12.7 (44.6)	—	11.1 (39.0)	16.2 (57.0)	15.7 (55.2)	17.1 (60.0)	11.7 (41.2)	37.7 (132.3)	200RB 7S5VLC	064037
	7/16	5/8 ODF	Yes	17.0 (59.8)	12.7 (44.6)	—	11.1 (39.0)	16.2 (57.0)	15.7 (55.2)	17.1 (60.0)	11.7 (41.2)	37.7 (132.3)	200RB 7T5VLC	064063
	7/16	7/8 ODF	Yes	17.0 (59.8)	12.7 (44.6)	—	11.1 (39.0)	16.2 (57.0)	15.7 (55.2)	17.1 (60.0)	11.7 (41.2)	37.7 (132.3)	200RB 7T7VLC	064282
Bi-Directional	3/16	3/8 ODF	Yes	4.8 (17.0)	4.4 (15.6)	5.0 (17.6)	3.2 (11.3)	4.5 (16.0)	4.5 (15.8)	5.6 (19.6)	3.3 (11.6)	10.9 (38.2)	200RB 3T3BFVLC	009689
	1/4	3/8 ODF	Yes	5.6 (19.8)	5.3 (18.6)	5.8 (20.4)	3.7 (13.1)	5.3 (18.8)	7.5 (26.4)	9.2 (32.4)	5.5 (19.3)	18.0 (63.3)	200RB 4T3BFVLC	009690
	5/16	1/2 ODF	Yes	8.2 (29.0)	7.8 (27.7)	8.6 (30.2)	5.4 (19.1)	7.8 (27.6)	7.7 (26.4)	9.5 (33.5)	5.7 (19.9)	18.7 (65.5)	200RB 5T4BFVLC	009692
		5/8 ODF	Yes	8.2 (29.0)	7.8 (27.7)	8.6 (30.2)	5.4 (19.1)	7.8 (27.6)	7.7 (26.4)	9.5 (33.5)	5.7 (19.9)	18.7 (65.5)	200RB 5T5BFVLC	009693
	3/8	5/8 ODF	Yes	10.0 (35.4)	9.4 (33.4)	9.9 (34.8)	6.5 (23.0)	9.5 (33.6)	8.9 (31.3)	11.0 (38.7)	6.5 (23.0)	21.5 (75.6)	200RB 6T5BFVLC	009694
Mounting Stud	1/8	1/4 ODF	Yes	3.6 (12.7)	2.7 (9.6)	3.8 (13.4)	2.3 (8.2)	3.4 (11.9)	3.4 (11.9)	3.6 (12.7)	2.5 (8.7)	8.2 (28.7)	200RB 2T2TVLC	053236
	1/8	3/8 ODF	Yes	3.6 (12.7)	2.7 (9.6)	3.8 (13.4)	2.3 (8.2)	3.4 (11.9)	3.4 (11.9)	3.6 (12.7)	2.5 (8.7)	8.2 (28.7)	200RB 2T3TVLC	054170
	3/16	3/8 SAE	—	4.8 (16.9)	3.6 (12.7)	5.0 (17.6)	3.1 (10.9)	4.5 (15.9)	4.5 (15.8)	4.8 (17.0)	3.3 (11.6)	10.9 (38.2)	200RB 3F3TVLC	056438
	3/16	3/8 ODF	Yes	4.8 (16.9)	3.6 (12.7)	5.0 (17.6)	3.1 (10.9)	4.5 (15.9)	4.5 (15.8)	4.8 (17.0)	3.3 (11.6)	10.9 (38.2)	200RB 3T3TVLC	049585
	3/16	1/2 SAE	—	4.8 (16.9)	3.6 (12.7)	5.0 (17.6)	3.1 (10.9)	4.5 (15.9)	4.5 (15.8)	4.8 (17.0)	3.3 (11.6)	10.9 (38.2)	200RB 3F4TVLC	055855
	1/4	3/8 SAE	—	8.0 (28.0)	6.0 (21.1)	8.3 (29.2)	5.1 (18.0)	7.5 (26.3)	7.5 (26.4)	8.0 (28.1)	5.5 (19.3)	18.0 (63.3)	200RB 4F3TVLC	047508
	1/4	3/8 ODF X 1/2 ODM	—	8.0 (28.0)	6.0 (21.1)	8.3 (29.2)	5.1 (18.0)	7.5 (26.3)	7.5 (26.4)	8.0 (28.1)	5.5 (19.3)	18.0 (63.3)	200RB 4S3TVLC	047513
	1/4	3/8 ODF	Yes	8.0 (28.0)	6.0 (21.1)	8.3 (29.2)	5.1 (18.0)	7.5 (26.3)	7.5 (26.4)	8.0 (28.1)	5.5 (19.3)	18.0 (63.3)	200RB 4T3TVLC	049162
	1/4	1/2 ODF X 5/8 ODM	—	8.0 (28.0)	6.0 (21.1)	8.3 (29.2)	5.1 (18.0)	7.5 (26.3)	7.5 (26.4)	8.0 (28.1)	5.5 (19.3)	18.0 (63.3)	200RB 4S4TVLC	047515
	1/4	1/2 ODF	Yes	8.0 (28.0)	6.0 (21.1)	8.3 (29.2)	5.1 (18.0)	7.5 (26.3)	7.5 (26.4)	8.0 (28.1)	5.5 (19.3)	18.0 (63.3)	200RB 4T4TVLC	049163
	1/4	5/8 ODF	Yes	8.0 (28.0)	6.0 (21.1)	8.3 (29.2)	5.1 (18.0)	7.5 (26.3)	7.5 (26.4)	8.0 (28.1)	5.5 (19.3)	18.0 (63.3)	200RB 4T5TVLC	058045
	5/16	3/8 ODF	Yes	8.2 (28.9)	6.2 (21.8)	8.6 (30.1)	5.3 (18.6)	7.7 (27.2)	7.7 (26.4)	8.3 (29.0)	5.7 (19.9)	18.7 (65.5)	200RB 5T3TVLC	054323
	5/16	1/2 SAE	—	8.2 (28.9)	6.2 (21.8)	8.6 (30.1)	5.3 (18.6)	7.7 (27.2)	7.7 (26.4)	8.3 (29.0)	5.7 (19.9)	18.7 (65.5)	200RB 5F4TVLC	047521
	5/16	1/2 ODF X 5/8 ODM	—	8.2 (28.9)	6.2 (21.8)	8.6 (30.1)	5.3 (18.6)	7.7 (27.2)	7.7 (26.4)	8.3 (29.0)	5.7 (19.9)	18.7 (65.5)	200RB 5S4TVLC	047526
	5/16	1/2 ODF	Yes	8.2 (28.9)	6.2 (21.8)	8.6 (30.1)	5.3 (18.6)	7.7 (27.2)	7.7 (26.4)	8.3 (29.0)	5.7 (19.9)	18.7 (65.5)	200RB 5T4TVLC	049164
	5/16	5/8 SAE	—	8.2 (28.9)	6.2 (21.8)	8.6 (30.1)	5.3 (18.6)	7.7 (27.2)	7.7 (26.4)	8.3 (29.0)	5.7 (19.9)	18.7 (65.5)	200RB 5F5TVLC	047523
	5/16	5/8 ODF	—	8.2 (28.9)	6.2 (21.8)	8.6 (30.1)	5.3 (18.6)	7.7 (27.2)	7.7 (26.4)	8.3 (29.0)	5.7 (19.9)	18.7 (65.5)	200RB 5S5TVLC	047528
	5/16	5/8 ODF	Yes	8.2 (28.9)	6.2 (21.8)	8.6 (30.1)	5.3 (18.6)	7.7 (27.2)	7.7 (26.4)	8.3 (29.0)	5.7 (19.9)	18.7 (65.5)	200RB 5T5TVLC	049165
	3/8	1/2 SAE	—	9.5 (33.3)	7.2 (25.2)	9.9 (34.7)	6.1 (21.5)	8.9 (31.4)	8.9 (31.3)	9.5 (33.5)	6.5 (23.0)	21.5 (75.6)	200RB 6F4TVLC	047531
	3/8	1/2 ODF X 5/8 ODM	—	9.5 (33.3)	7.2 (25.2)	9.9 (34.7)	6.1 (21.5)	8.9 (31.4)	8.9 (31.3)	9.5 (33.5)	6.5 (23.0)	21.5 (75.6)	200RB 6S4TVLC	047539
	3/8	1/2 ODF	Yes	9.5 (33.3)	7.2 (25.2)	9.9 (34.7)	6.1 (21.5)	8.9 (31.4)	8.9 (31.3)	9.5 (33.5)	6.5 (23.0)	21.5 (75.6)	200RB 6T4TVLC	047546
3/8	5/8 SAE	—	9.5 (33.3)	7.2 (25.2)	9.9 (34.7)	6.1 (21.5)	8.9 (31.4)	8.9 (31.3)	9.5 (33.5)	6.5 (23.0)	21.5 (75.6)	200RB 6F5TVLC	047534	
3/8	5/8 ODF	—	9.5 (33.3)	7.2 (25.2)	9.9 (34.7)	6.1 (21.5)	8.9 (31.4)	8.9 (31.3)	9.5 (33.5)	6.5 (23.0)	21.5 (75.6)	200RB 6S5TVLC	047542	
3/8	5/8 ODF	Yes	9.5 (33.3)	7.2 (25.2)	9.9 (34.7)	6.1 (21.5)	8.9 (31.4)	8.9 (31.3)	9.5 (33.5)	6.5 (23.0)	21.5 (75.6)	200RB 6T5TVLC	047548	

200RB Series Refrigerant Solenoid Valves (continued)

Valve config.	Port size (in)	Conn size & type (in)	Extd. ends	Nominal liquid capacity - tons (kw)									Model number	Item number
				R-22	R-134a	R-290	R-404a / R-507	R-407c	R-410a	R-448a / R-449a	R-450a / R-513a	R-744		
Mounting Stud	7/16	5/8 ODF	—	17.0 (59.8)	12.7 (44.6)	—	11.1 (39.0)	16.2 (57.0)	15.7 (55.2)	17.1 (60.0)	11.7 (41.2)	37.7 (132.3)	200RB 7T5TVLC	064562
		7/8 ODF	Yes			—							200RB 7T7TVLC	064284
Manual Opening Stem	3/16	3/8 ODF	—	4.8 (16.9)	3.6 (12.7)	5.0 (17.6)	3.1 (10.9)	4.5 (15.9)	4.5 (15.8)	4.8 (17.0)	3.3 (11.6)	10.9 (38.2)	200RB 3T3MVLC	065620
		1/2 ODF	—										200RB 3T4MVLC	065621
	1/4	3/8 SAE	—	8.0 (28.0)	6.0 (21.1)	8.3 (29.2)	5.1 (18.0)	7.5 (26.3)	7.5 (26.4)	8.0 (28.1)	5.5 (19.3)	18.0 (63.3)	200RB 4F3MVLC	047507
		3/8 ODF X 1/2 ODM	—										200RB 4S3MVLC	047512
		3/8 ODF	Yes										200RB 4T3MVLC	049186
		1/2 ODF X 5/8 ODM	—										200RB 4S4MVLC	047514
		1/2 ODF	Yes										200RB 4T4MVLC	049187
		5/8 ODF	Yes										200RB 4T5MVLC	056518
	5/16	1/2 SAE	—	8.2 (28.9)	6.2 (21.8)	8.6 (30.1)	5.3 (18.6)	7.7 (27.2)	7.7 (26.4)	8.3 (29.0)	5.7 (19.9)	18.7 (65.5)	200RB 5F4MVLC	047520
		1/2 ODF X 5/8 ODM	—										200RB 5S4MVLC	047525
		1/2 ODF	Yes										200RB 5T4MVLC	049188
		5/8 SAE	—										200RB 5F5MVLC	047522
		5/8 ODF	—										200RB 5S5MVLC	047527
		5/8 ODF	Yes										200RB 5T5MVLC	049189
	3/8	1/2 SAE	—	9.5 (33.3)	7.2 (25.2)	9.9 (34.7)	6.1 (21.5)	8.9 (31.4)	8.9 (31.3)	9.5 (33.5)	6.5 (23.0)	21.5 (75.6)	200RB 6F4MVLC	047530
		1/2 ODF X 5/8 ODM	—										200RB 6S4MVLC	047538
		1/2 ODF	Yes										200RB 6T4MVLC	047545
		5/8 ODF	—										200RB 6S5MVLC	047541
		5/8 ODF	Yes										200RB 6T5MVLC	047547
	7/16	5/8 ODF	Yes	17.0 (59.8)	12.7 (44.6)	—	11.1 (39.0)	16.2 (57.0)	15.7 (55.2)	17.1 (60.0)	11.7 (41.2)	37.7 (132.3)	200RB 7T5MVLC	064267
		7/8 ODF	Yes			200RB 7T7MVLC							064283	

Capacities based on 100°F liquid and 40°F saturated evaporator per ARI standard 760-87. All ratings are based on largest connection size.



Detailed product drawings

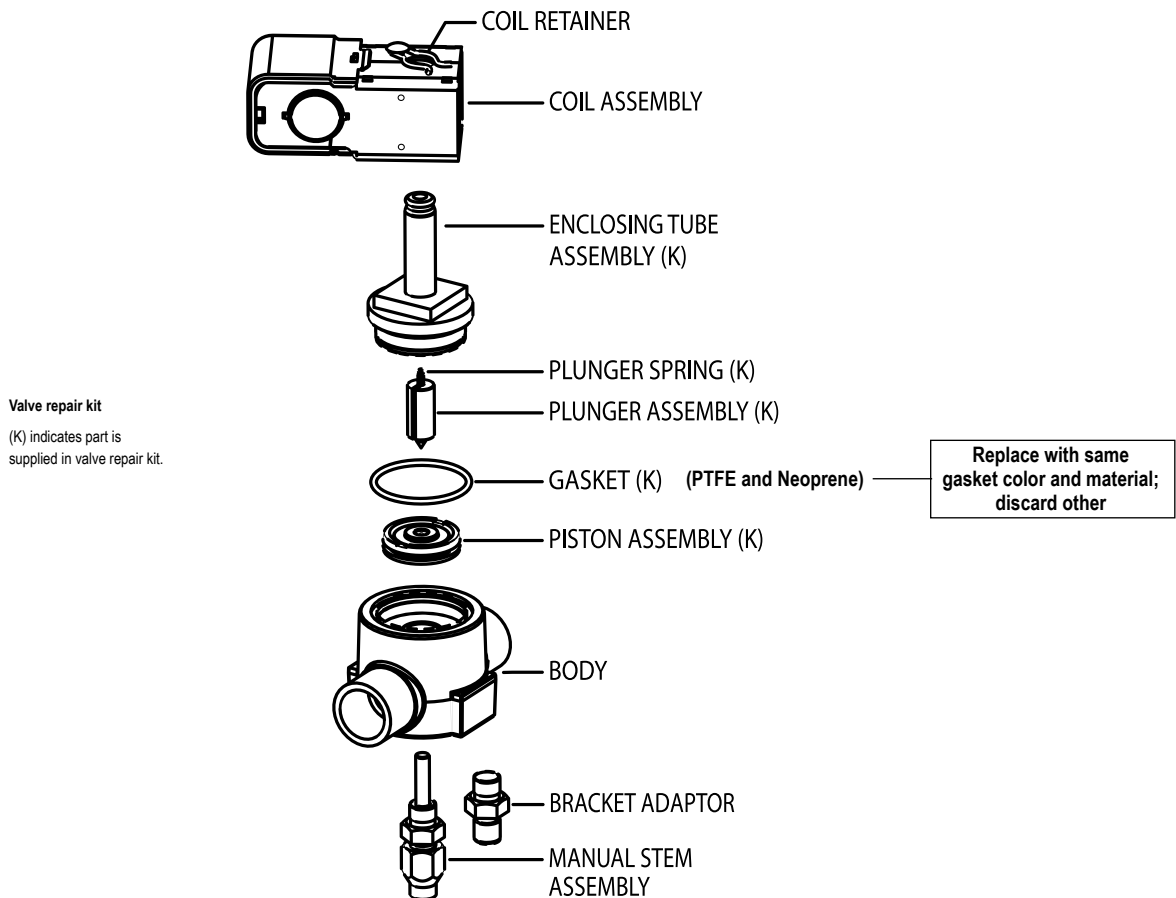


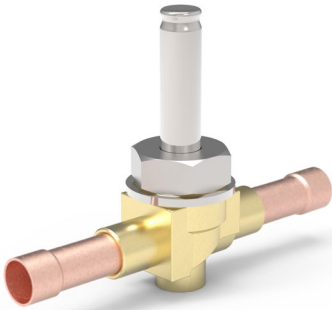
Extended capacity tables

Exploded view & parts kit data

200RB series part kits

Description	Model number	Item number
<b>Complete kits</b>		
Complete Valve Repair Kit (K) for 200RB/RD 2 - 200RB/RD 6	KS-30115	049194
Complete Valve Repair Kit (K) for 200RB/RD 7	KS-30354	064263
Complete Valve Repair Kit (K) for 200RB/RD 9	KS-30362	064825
<b>Manual opener kits</b>		
Solenoid Valve Manual Opener Kit 200RB 3	KS-30377	065695
Solenoid Valve Manual Opener Kit 200RB 4 - 200RB 6	KS-30117	053959
Solenoid Valve Manual Opener Kit 200RB 7	KS-30361	064831
Solenoid Valve Manual Opener Kit 200RB 9	KS-30364	064832
<b>Gasket Kits</b>		
Gasket Kit for 200RB/RD 7	KG-00002	064262
Gasket Kit for 200RB/RD 9	KG-00003	064830
Gasket Kit for 200RB/RD 2 - 200RB/RD 6 and 500RB, 12 PTFE and 12 Neoprene O-Rings	KG-10025	049190
<b>Bi-directional kit</b>		
B-Directional Flow Valve Kit for 200RB/RD 2 - 200RB/RD 6	KS-30293	056431
<b>Tool kit</b>		
Magnetic Solenoid Tool closes a normally closed solenoid valve in the de-energized state, incorporates a spanner wrench for easy disassembly of solenoid valve series 100RB, 200RB, 240RA and provides an orifice to manually adjust opening stem.	Solenoid tool	066019





**200RC 4T4 VLC 802081**

# 200RC Series Refrigerant Solenoid Valves

The 200RC Series is a pilot-operated, 2-way, normally closed valve used for liquid, discharge, or suction gas refrigerant service. It is designed specifically for R-744 refrigeration systems.

## Features

- Designed for the high pressure requirements of R-744 refrigeration systems
- Brass forged body with copper connections
- Extended ends for easy installation
- Mounting screw with washer
- Coil Options: AM and DM Series (24 vac 50/60 Hz, 120 vac 50/60 Hz, and 208-240 vac 50/60 Hz)

## Specifications

Maximum fluid temperature.....	250°F (121°C)
Maximum working pressure.....	1885 psig (130 bar)
Maximum operating pressure differential (MOPD - See COILS).....	Up to 870 psig (60 bar)
Minimum operating pressure differential.....	2 psi (0.15 bar)
UL/CUL file number.....	MP604
Marking.....	CE, UKCA

**Model number nomenclature - Example: 200RC 4T4 VLC 802081**

Valve series	Design series	Port size	Connection type	Connection size	Coil*	Unique identifier
200R	C	4	T	4	VLC	802081
Pilot-Operated Normally Closed Refrigerant Solenoid Valve	C = CO2	In 1/16"	T = ODF Extended Ends	In 1/8"	VLC = Valve Less Coil	

\* Valves in catalog are shipped without solenoid coils (VLC = Valve Less Coil). See COILS table below for ordering information.

**200RC series valves: Nominal R-744 capacities - tons (kw)**

Port size (in.)	Connection size (in.) & Type	Cv	Liquid	Suction	Discharge	Model number	Item number
3/16	3/8 ODF	0.95	10.9 (38.2)	0.94 (3.30)	1.16 (4.09)	200RC 3T3 VLC 802080	802080
1/4	1/2 ODF	1.35	18.0 (63.3)	1.76 (6.19)	2.18 (7.67)	200RC 4T4 VLC 802081	802081

Liquid nominal capacities are determined at 20°F (-7°C) evaporating temperature and 7 psi (0.5 bar) drop across solenoid valve.  
 Suction gas nominal capacities are determined at 20°F (-7°C) Liquid, -20°F (-29°C) Evaporating Temperature, 25°F (14°C) Superheat and 2 psi (0.15 bar) drop across solenoid valve.  
 Discharge gas nominal capacities are determined at 2 psi (0.15 bar) pressure drop across solenoid valve.  
 Flow coefficient Cv is US gallons per minute (gpm) of water at 60°F with 1 psi pressure drop across the valve.

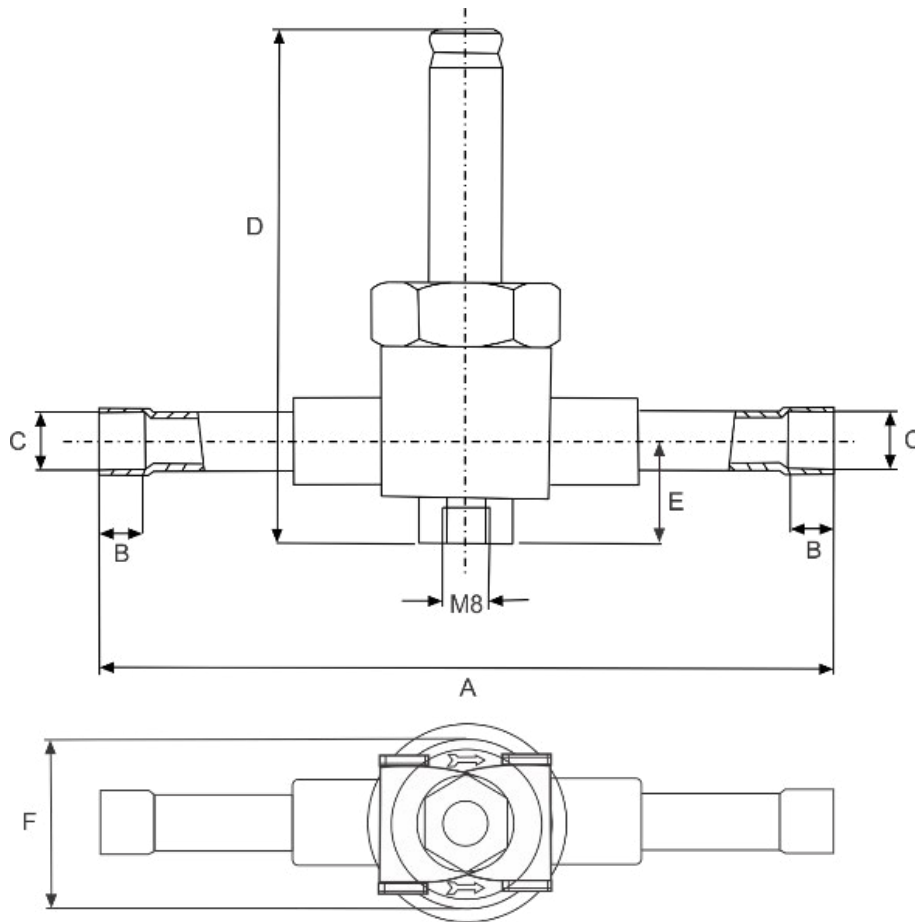
**Recommended coils for 200RC series valves**

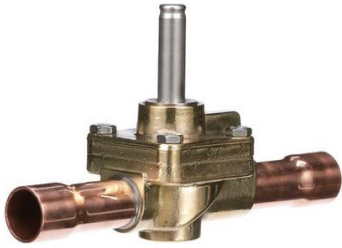
Coil series	Voltage	Watts	Mopd	Enclosure type	Lead	Model number	Item number
AMG	24 (50/60 Hz)	17/12	870 psi (60 bar)	Junction Box	6 inch (152 mm)	AMG 1-01	057341
	120 (50/60 Hz)	17/12	870 psi (60 bar)			AMG 2-01	057331
	120-240 (50/60 Hz)	17/12	870 psi (60 bar)			AMG 4-01	057343
	208-220 (50 Hz)	17	870 psi (60 bar)	Junction Box	6 inch (152 mm)	AMG 3-01	057342
208-240 (60 Hz)	12	780 psi (54 bar)					

Additional AM and DM Series coils are approved with the same pressure ratings shown above for 24 vac, 120 vac, and 208-240 vac only. See catalog for ordering information

200RC dimensions - in. (mm)

Model number	C	A	B	D	E	F
200RC 3T3 VLC 802080	3/8 (10)	5.0 (126)	0.3 (8)	3.5 (88)	0.7 (18)	1.1 (29)
200RC 4T4 VLC 802081	1/2 (12)	5.0 (126)	0.4 (10)	3.5 (88)	0.7 (18)	1.1 (29)





250RA 12T9VLC-01

# 250RA Series Refrigerant Solenoid Valves

The 250RA is a 2-way, normally closed diaphragm valve used for liquid, suction, and hot gas service. It is applied in various commercial air-conditioning and refrigeration systems.

## Features

- Single coil family fits all sizes
- Can be brazed into the line without disassembly
- Compatible with all common A1 and A2L class refrigerants (refer to the capacity tables)
- Upgraded diaphragm design for high temperature and pressure applications
- Extended ends for easy installation (standard)
- Mounting stud models can be field converted to manual stem

## Specifications

Maximum fluid temperature..... A1: 250° F (121° C)  
 ..... A2L: 221° F (105° C)  
 Maximum working pressure ..... 680 psig (47 bar)  
 Maximum operating pressure differential..... 300 psig (21 bar)  
 UL/CUL file number.....MP604

Model number nomenclature - Example: 250RA 12T9VLC-01

Valve series	Design series	Port size	Connection type	Connection size	Valve configuration	*Coil	Sequential identifier	Customer special	Pack type
250R	A	12	T	9	M	VLC	-01 Thru -99	G = Customer Special	B1 = Bulk Pack
Normally Closed Solenoid Valves with increased MWP	Diaphragm Design	In 1/16"	T = ODF Extended End	In 1/8"	M = Manual Opening Stem T = Mounting Stud  (Omit for Standard)	VLC = Valve Less Coil  For Valves with Coil See Coil Nomenclature on Coil Catalog Page		(Omit for Standard)	(Omit for Individual Pack)

\* Valves in catalog are shipped without solenoid coils (VLC = Valve Less Coil). See Coil pages for coil selection and a complete list of voltage options.

## 250RA Series Refrigerant Solenoid Valves

Valve config.	Port size (in)	Conn. Size & type	Nominal liquid capacity - tons (kw)											Model number	Item number	
			R134a	R22	R32	R404a / R507	R407a	R407c	R410a	R448a / R449a	R450a / R513a	R-454a	R454b / R452b			
Standard Valve	1/2	5/8 ODF													250RA 8T5VLC-01	1838403
Mounting Stud		5/8 ODF	12.1 (42.6)	15.6 (54.9)	21.2 (74.6)	10.3 (36.2)	11.0 (38.8)	14.8 (52.1)	14.6 (51.2)	15.7 (55.1)	10.8 (37.8)	14.5 (51.0)	14.1 (49.6)	250RA 8T5TVLC-01	1838391	
Manual Opening Stem		5/8 ODF													250RA 8T5MVLC-01	1840052
Manual Opening Stem		7/8 ODF													250RA 8T7MVLC-01	1840061
Standard Valve	9/16	7/8 ODF													250RA 9T7VLC-01	1838420
Mounting Stud		7/8 ODF	21.0 (74.0)	30.5 (107.3)	41.5 (145.9)	20.1 (70.7)	21.6 (75.9)	29.0 (102.0)	28.5 (100.2)	30.6 (107.7)	21.0 (74.0)	28.3 (99.6)	27.6 (97.0)	250RA 9T7TVLC-01	1838411	
Manual Opening Stem		5/8 ODF													250RA 9T5MVLC-01	1840079
Manual Opening Stem		7/8 ODF													250RA 9T7MVLC-01	1840087
Standard Valve	3/4	1-1/8 ODF													250RA 12T9VLC-01	1838340
Mounting Stud		1-1/8 ODF	27.1 (95.3)	34.9 (122.7)	47.5 (166.9)	23.0 (80.9)	24.7 (86.9)	33.2 (116.8)	32.6 (114.6)	29.0 (102.0)	24.1 (84.6)	32.4 (114.0)	31.5 (111.0)	250RA 12T9TVLC-01	1838331	
Manual Opening Stem		7/8 ODF													250RA 12T7MVLC-01	1839991
Manual Opening Stem		1-1/8 ODF													250RA 12T9MVLC-01	1840001
Standard Valve	1	1-3/8 ODF													250RA 16T11VLC-01	1838366
Mounting Stud		1-3/8 ODF	45.0 (158.3)	58.0 (203.9)	78.9 (277.4)	38.3 (134.7)	41.1 (144.4)	55.2 (194.1)	54.2 (190.5)	58.2 (204.8)	40.0 (140.6)	53.9 (189.4)	52.4 (184.4)	250RA 16T11TVLC-01	1838358	
Manual Opening Stem		1-1/8 ODF													250RA 16T9MVLC-01	1840028
Manual Opening Stem		1-3/8 ODF													250RA 16T11MVLC-01	1840010
Standard Valve	1-1/4	1-5/8 ODF													250RA 20T13VLC-01	1838382
Mounting Stud		1-5/8 ODF	70.9 (249.4)	95.4 (335.5)	129.7 (456.3)	65.7 (231.1)	67.5 (237.5)	90.8 (319.3)	89.1 (313.4)	95.8 (336.8)	65.8 (231.3)	88.6 (311.6)	86.2 (303.3)	250RA 20T13TVLC-01	1838374	
Manual Opening Stem		1-3/8 ODF													250RA 20T11MVLC-01	1840036
Manual Opening Stem		1-5/8 ODF													250RA 20T13MVLC-01	1840044

Capacities based on 100°F liquid and 40°F saturated evaporator per AHRI standard 760. All ratings are based on largest connection size.

250RA series part kits

Description	Model number	Item number
<b>Repair kits</b>		
250RA 8 Solenoid Valve Repair Kit (K)	KS-30401	1838462
250RA 9 Solenoid Valve Repair Kit (K)	KS-30402	1838471
250RA 12 Solenoid Valve Repair Kit (K)	KS-30403	1838489
250RA 16 Solenoid Valve Repair Kit (K)	KS-30404	1838497
240RA, 250RA 20 Solenoid Valve Complete Kit (K)	KS-30325	060630
<b>Manual opener kits</b>		
240RA, 250RA 8 Solenoid Valve Manual Opener Kit (M)	KS-30066	044657
240RA, 250RA 9 and 12 Solenoid Valve Manual Opener Kit (M)	KS-30067	044658
240RA, 250RA 16 Solenoid Valve Manual Opener Kit (M)	KS-30068	044491
240RA, 250RA 20 Solenoid Valve Manual Opener Kit (M)	KS-30098	047723
<b>Gasket kits</b>		
240RA, 250RA, 540RA Gasket Kit (G)	KG-10028	054356
<b>Tool kits</b>		
Magnetic Solenoid Tool opens a normally closed solenoid valve in the de-energized state and provides an orifice to manually adjust opening stem.	Solenoid tool	066019

**Valve repair kit**

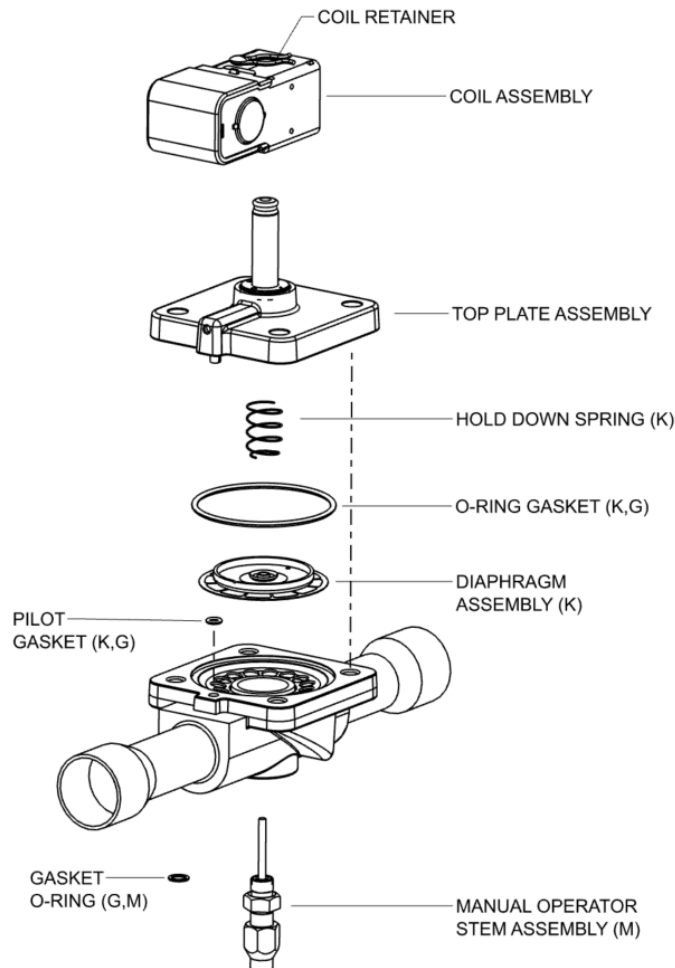
(K) indicates part is supplied in valve repair kit.

**Manual stem kit**

(M) indicates part is supplied in manual stem kit

**Gasket kit**

(G) indicates gasket is supplied in gasket kit.



Exploded view & parts kit data

240RA series part kits

Description	Model number	Item number
<b>Complete kits</b>		
200RA 8 Solenoid Valve Complete Kit (K)	KS-30321	060626
200RA 9 Solenoid Valve Complete Kit (K)	KS-30322	060627
240RA 12 Solenoid Valve Complete Kit (K)	KS-30323	060628
240RA 16 Solenoid Valve Complete Kit (K)	KS-30324	060629
240RA 20 Solenoid Valve Complete Kit (K)	KS-30325	060630
<b>Manual opener kits</b>		
240RA 8 Solenoid Valve Manual Opener Kit (M)	KS-30066	044657
240RA 9 and 240RA 12 Solenoid Valve Manual Opener Kit (M)	KS-30067	044658
240RA 16 Solenoid Valve Manual Opener Kit (M)	KS-30068	044491
240RA 20 Solenoid Valve Manual Opener Kit (M)	KS-30098	047723
<b>Gasket kits</b>		
240RA and 540RA Gasket Kit (G)	KG-10028	054356
<b>Tool kits</b>		
100RB, 240RA and 540RA Solenoid Valve Universal (2/3 hole) Spanner Wrench (Included in complete valve kit)	X-11981-1	027451
Magnetic Solenoid Tool opens a normally closed solenoid valve in the de-energized state, incorporates a spanner wrench for easy disassembly of solenoid valve series 100RB, 200RB, 240RA, and provides an orifice to manually adjust opening stem.	Solenoid tool	066019

**Valve repair kit**

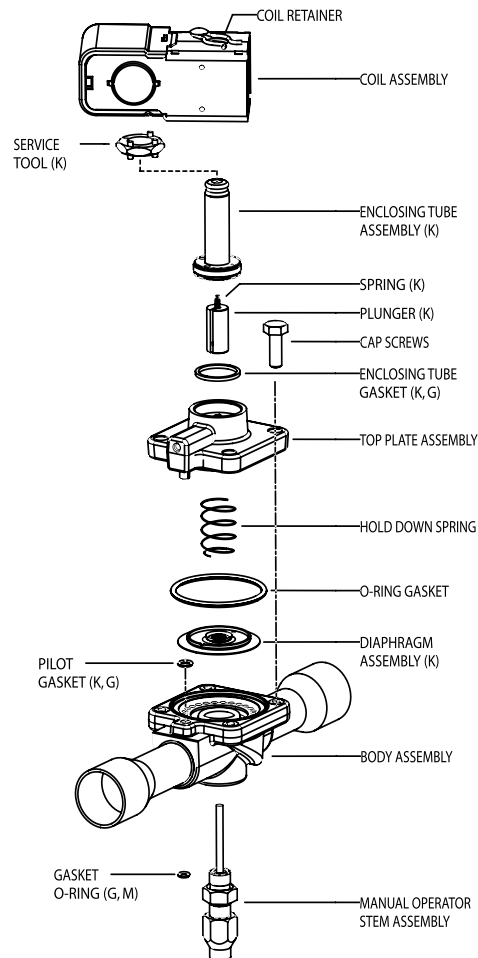
(K) indicates part is supplied in valve repair kit.

**Manual stem kit**

(M) indicates part is supplied in manual stem kit

**Gasket kit**

(G) indicates gasket is supplied in gasket kit.





500RB 4T3VLC

# 500RB Series Refrigerant Solenoid Valves

The 500RB is a pilot-operated, normally open valve used for liquid, suction and hot gas service.

## Features

- Single coil family fits all valve sizes
- Extended ends for easy installation
- Low pressure differential required for full opening
- Optional SAE, ODF, NPTF and ODF inlet with ODM outlet
- Field serviceable parts available
- Compatible with all common A1, A2L, and A3 class refrigerants (refer to the capacity tables)

## Specifications

Maximum fluid temperature.....250°F (121°C)  
 Maximum working pressure.....680 psig (47 bar)  
 Maximum operating pressure differential.....275 psig (19 bar)  
 UL/CUL file number.....MP604

### Model number nomenclature - Example: 500RB 4T3VLC

Valve series	Design series	Port size	Connection type	Connection size	*Coil	Sequential identifier	Customer special	Pack type
500R	B	4	T	3	VLC			
Pilot-Operated Normally Open Refrigerant Solenoid Valves	Piston Design	In 1/16" Increments	F = SAE P = NPTF S = ODF Inlet/ODM Outlet T = ODF (Copper Extended Fittings)	Connection Size In 1/8" Increments	VLC = Valve Less Coil  For Valves with Coil See Coil Nomenclature on Coil Catalog Page	Blank Thru -99	G = Customer Special  (Omit for Standard)	B1 = Bulk Pack  (Omit for Individual Pack)

\* Valves are shipped without the solenoid coils (VLC = Valve Less Coil). See coil assemblies for availability. Valves require a DM, MM coil.

### 500RB Series Refrigerant Solenoid Valves

Port size (in)	Connection size & type	Nominal liquid capacity - tons (kw)									Model number	Item number
		R-22	R-134a	R-290	R-404a / R-507	R-407c	R410a	R-448a / R-449a	R-450a / R-513a	R-744		
1/8	1/4" ODF										500RB 2T2VLC	063278
	3/8" ODF										500RB 2T3VLC	063280
3/16	1/2" SAE	4.8 (16.9)	3.6 (12.7)	5.0 (17.6)	3.1 (10.9)	4.5 (15.9)	4.5 (15.9)	4.8 (17.0)	3.3 (11.6)	10.9 (38.2)	500RB 3F4VLC	063286
1/4	3/8" ODF										500RB 4T3VLC	063306
	1/2" ODF	8.0 (28.0)	6.0 (21.1)	8.3 (29.2)	5.1 (18.0)	7.5 (26.3)	7.5 (26.3)	8.0 (28.1)	5.5 (19.3)	18.0 (63.3)	500RB 4T4VLC	063308
	5/8" ODF										500RB 4T5VLC	063310
5/16	3/8" ODF										500RB 5T3VLC	063322
	1/2" ODF X 5/8" ODM	8.2 (21.8)	6.2 (21.8)	8.6 (30.1)	5.3 (18.6)	7.7 (27.2)	7.7 (27.2)	8.3 (29.0)	5.7 (19.9)	18.7 (65.5)	500RB 5S4VLC	063318
	5/8" ODF										500RB 5S5VLC	063320
3/4	5/8" SAE										500RB 6F5VLC	063329
	5/8" ODF	9.5 (33.3)	7.2 (25.2)	9.9 (34.7)	6.1 (21.5)	8.9 (31.4)	8.9 (31.4)	9.5 (33.5)	6.5 (23.0)	21.5 (75.6)	500RB 6S5VLC	063335
	1/2" ODF										500RB 6T4VLC	063339
7/16	1/2" ODF										500RB 7T4VLC	064064
	5/8" ODF X 7/8" ODM	17.0 (59.8)	12.7 (44.6)	—	11.1 (39.0)	16.2 (57.0)	15.7 (55.2)	17.1 (60.0)	11.7 (41.2)	37.7 (132.3)	500RB 7S5VLC	064038

NOTE: Capacities based on 100°F liquid and 40°F saturated evaporator per ARI standard 760-87. All ratings are based on largest connection size.

500RB Series Refrigerant Solenoid Valves (continued)

Port size (in)	Connection size & type	Nominal liquid capacity - tons (kw)									Model number	Item number
		R-22	R-134a	R-290	R-404a / R-507	R-407c	R410a	R-448a / R-449a	R-450a / R-513a	R-744		
3/4	3/8" NPTF	9.5 (33.3)	7.2 (25.2)	9.9 (34.7)	6.1 (21.5)	8.9 (31.4)	8.9 (31.4)	9.5 (33.5)	6.5 (23.0)	21.5 (75.6)	500RB 6P3VLC	063331
	1/2" ODF X 5/8" ODM										500RB 6S4VLC	063333
	5/8" SAE										500RB 6F5VLC	063329
	5/8" ODF										500RB 6S5VLC	063335
	1/2" ODF										500RB 6T4VLC	063339
7/16	1/2" ODF	17.0 (59.8)	12.7 (44.6)	—	11.1 (39.0)	16.2 (57.0)	15.7 (55.2)	17.1 (60.0)	11.7 (41.2)	37.7 (132.3)	500RB 7T4VLC	064064
	5/8" ODF X 7/8" ODM										500RB 7S5VLC	064038

NOTE: Capacities based on 100°F liquid and 40°F saturated evaporator per ARI standard 760-87. All ratings are based on largest connection size.

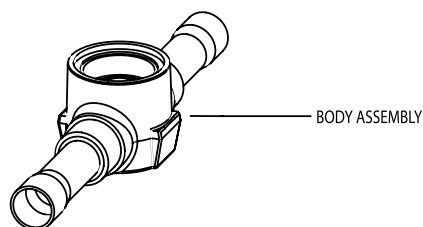
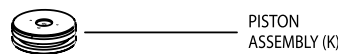
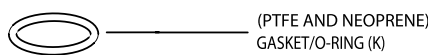
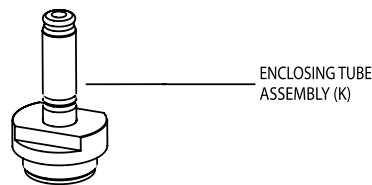
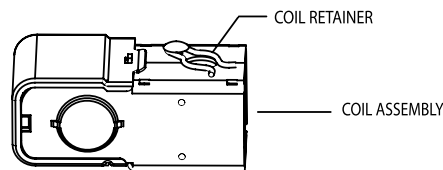
Exploded view & parts kit data

500RB series part kits

Description	Model number	Item number
500RB 2 - 500RB 6 Solenoid Valve Repair Kit (K), Enclosing Tube Assembly and Gasket (PTFE and Neoprene) and Piston Assembly	KS-30353	064268
500RB 7 Solenoid Valve Repair Kit (K), Enclosing Tube Assembly and Gasket (PTFE and Neoprene) and Piston Assembly	KS-30355	064264
200RB 2 - 200RB 6 and 500RB Solenoid Valve Gasket Kit, 12 PTFE and 12 Neoprene O-Rings	KG-10025	049190
Magnetic Solenoid Tool closes a normally open solenoid valve in the de-energized state, incorporates a spanner wrench for easy disassembly of solenoid valve series 500RB, 540RA and provides an orifice to manually adjust opening stem.	Solenoid tool	066019

Valve repair kit

(K) indicates part is supplied in valve repair kit.



Detailed product drawings

Extended capacity tables





540RA 9T7TVLC

# 540RA Series Refrigerant Solenoid Valves

The 540RA is a 2-way, normally open diaphragm valve used for liquid, suction and hot gas service.

## Features

- Single coil family fits all valve sizes
- Can be brazed into the line without disassembly
- Extended ends for easy installation
- Low pressure differential required for full opening
- Field serviceable parts available

## Specifications

Maximum fluid temperature.....250°F (121°C)  
 Maximum working pressure.....500 psig (35 Bar)  
 Maximum operating pressure differential.....250 psig (17 bar)  
 UL/CUL file number.....MP604

Model number nomenclature - Example: 540RA 8T5VLC

Valve series	Design series	Port size	Connection type	Connection size	Valve configuration	*Coil	Sequential identifier	Customer special	Pack type
540R	A	8	T	5		VLC			
Normally Open Refrigerant Solenoid Valve	Diaphragm Design	In 1/16"	T = Copper Extended Ends	In 1/8"	M = Manual Opening Stem T = Mounting Stud  (Omit for Std. Valve)	VLC = Valve Less Coil  For Valves with Coil See Coil Nomenclature on Coil Catalog Page	Blank Thru -99	G = Customer Special  (Omit for Standard)	B1 = Bulk Pack  (Omit for Individual Pack)

\* Valves are shipped without the solenoid coils (VLC = Valve Less Coil). See coil assemblies for availability. Valves require a DM, MM or ASC2 type coil assembly.

## 540RA Series Refrigerant Solenoid Valves

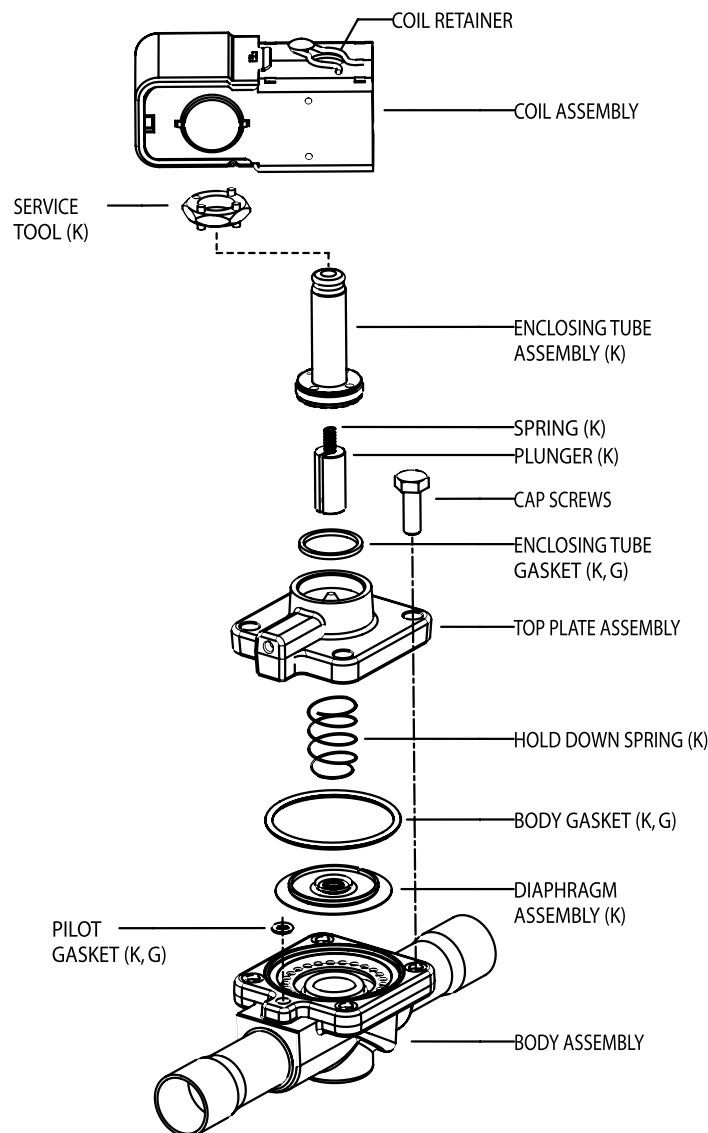
Valve config.	Port size (in)	Connection size & type	Nominal liquid capacity - tons (kw)						Model number	Item number
			R-22	R-134a	R-404a / R-507	R-407c	R-448a / R-449a	R-450a / R-513a		
Standard Valve	1/2	5/8" ODF	15.6 (54.9)	12.1 (42.6)	10.3 (36.2)	14.8 (52.1)	15.7 (55.1)	10.8 (37.8)	540RA 8T5VLC	060392
Standard Valve	9/16	7/8" ODF	30.5 (107.3)	21.0 (74.0)	20.1 (70.7)	29.0 (102.0)	30.6 (107.7)	21.0 (74.0)	540RA 9T7VLC	060395
Standard Valve	3/4	7/8" ODF	34.9 (122.7)	27.1 (95.3)	23.0 (80.9)	33.2 (116.8)	35.0 (123.2)	24.1 (84.6)	540RA 12T7VLC	060397
Standard Valve		1-1/8" ODF							540RA 12T9VLC	060398
Standard Valve	1	1-1/8" ODF	58.0 (203.9)	45.0 (158.3)	38.3 (134.7)	55.2 (194.1)	58.2 (204.8)	40.0 (140.6)	540RA 16T9VLC	060399
Standard Valve	1-1/4	1-5/8" ODF	95.4 (335.5)	70.9 (249.4)	65.7 (231.1)	90.8 (319.3)	95.8 (336.8)	65.8 (231.3)	540RA 20T13VLC	060402
Mounting Stud	1/2	5/8" ODF	15.6 (54.9)	12.1 (42.6)	10.3 (36.2)	14.8 (52.1)	15.7 (55.1)	10.8 (37.8)	540RA 8T5TVLC	046265
Mounting Stud	9/16	5/8" ODF	23.3 (81.9)	18.0 (63.3)	15.3 (53.8)	22.1 (77.2)	23.4 (82.3)	16.1 (56.5)	540RA 9T5TVLC	046266
Mounting Stud		7/8" ODF	30.5 (107.3)	21.0 (74.0)	20.1 (70.7)	29.0 (102.0)	30.6 (107.7)	21.0 (74.0)	540RA 9T7TVLC	046268
Mounting Stud	3/4	7/8" ODF	34.9 (122.7)	27.1 (95.3)	23.0 (80.9)	33.2 (116.8)	35.0 (123.2)	24.1 (84.6)	540RA 12T7TVLC	046269
Mounting Stud	1	1-1/8" ODF	58.0 (203.9)	45.0 (158.3)	38.3 (134.7)	55.2 (194.1)	58.2 (204.8)	40.0 (140.6)	540RA 16T9TVLC	046270
Mounting Stud	1-1/4	1-3/8" ODF	95.4 (335.5)	70.9 (249.4)	65.7 (231.1)	90.8 (319.3)	95.8 (336.8)	65.8 (231.3)	540RA 20T11TVLC	047953

NOTE: Capacities based on 100°F liquid and 40°F saturated evaporator per ARI standard 760-87. All ratings are based on largest connection size.

540RA series parts list

Description	Model number	Item number
<b>Complete kits</b>		
540RA 8 Solenoid Valve Repair Kit (K), Enclosing Tube Assembly and Gasket, Plunger and Spring, Hold Down Spring, Body Gasket and Diaphragm Assembly	KS-30328	060633
540RA 9 Solenoid Valve Repair Kit (K), Enclosing Tube Assembly and Gasket, Plunger and Spring, Hold Down Spring, Body Gasket and Diaphragm Assembly	KS-30329	060634
540RA 12 Solenoid Valve Repair Kit (K), Enclosing Tube Assembly and Gasket, Plunger and Spring, Hold Down Spring, Body Gasket and Diaphragm Assembly	KS-30330	060635
540RA 16 Solenoid Valve Repair Kit (K), Enclosing Tube and Gasket, Plunger and Spring, Hold Down Spring, Body Gasket and Diaphragm Assembly	KS-30331	060636
540RA 20 Solenoid Valve Repair Kit (K), Enclosing Tube and Gasket, Plunger and Spring, Hold Down Spring, Body Gasket and Diaphragm Assembly	KS-30332	060637
<b>Gasket kit</b>		
240RA and 540RA Gasket Kit (G)	KG-10028	054356
<b>Tool kits</b>		
100RB, 240RA and 540RA Solenoid Valve Universal (2/3 hole) Spanner Wrench (Included in complete valve kit)	X-11981-1	027451
Magnetic Solenoid Tool closes a normally open solenoid valve in the de-energized state, incorporates a spanner wrench for easy disassembly of solenoid valve series 500RB, 540RA and provides an orifice to manually adjust opening stem.	Solenoid tool	066019

Exploded view & parts kit data



**Valve repair kit**

(K) indicates part is supplied in valve repair kit.

**Gasket kit**

(G) indicates gasket is supplied in gasket kit.



066019

# Solenoid Multi-Purpose Tool

The Solenoid Multi-Purpose Tool is a magnetic tool that holds key components together as the valve is disassembled. The manual stem adjustment makes it easy to open valves. This tool provides longer life utilizing its spanner wrench which not only makes it easier to service valves, but also protects the enclosing tube from damage.

## Features

- Magnet opens a normally closed Copeland solenoid valve that is in the de-energized state
- Incorporates a spanner wrench and drive socket which enables easy disassembly of Copeland solenoid valves 100RB & 240RA/540RA by using a 3/8" socket wrench
- Tool has a manual stem orifice used to manually adjust opening stem
- May reassemble valve with proper torque specifications on collar

## Specifications

Drive socket size.....3/8"

### Torque specifications

100RB Series	225 in. lbs. (102.06 kg)
240RA Series	150 in. lbs. (68.04 kg)
540RA Series	150 in. lbs. (68.04 kg)

### Solenoid multi-purpose tool

Model number	Item number
SOLENOID TOOL	066019

# Coils for solenoid valves

A wide range of coils for Refrigerant and Industrial Solenoid Valves in various voltages and configurations.



AMS - OPEN FRAME

## Features

- Compact designs
- Coil windings are insulated to provide shock and vibration protection
- ASC2 is designed to provide weather protection
- Interchangeable housings
- Snap-on coil design provides easy installation for A, D and M series coils



ASC2 - DIN

Requires ASC2 female connector (Item Number 059261).  
For UL50 Type 4 Enclosure.



MMG - SPECIAL DC



AMC - 1/2" CONDUIT



AMG - JUNCTION BOX

### Model number nomenclature - Example: AMG 5-01

Series	Insulation	Enclosure**	Coil code		Sequential identifier	Customer special	Pack type
A	M	G	5		-1		
A = 12 Watt B = 15 Watt D = 7 Watt M = 4 Watt R = 7 Watt	B or G = Class B M = Class F H = Class H	C = Conduit F = Open Frame with Leads G = Junction Box L = Grommet 18" Leads S = Open Frame with Spade Connection  ** C and G are UL / Canadian Listed ** F, L and S are UL / Canadian Recognized	1 = 24 50/60 2 = 120 50/60 3 = 208-220 50, 208-240 60 4 = 120-240 50/60 5 = 12dc 6 = 24dc 7 = 100 50/60 8 = 120 60 9 = 200 50/60 10 = 208-240 50/60 11 = 220 50/60	12 = 200-240 50/60 13 = 220/240, 50/60 14 = 230 50/60 15 = 240 50/60 16 = 255 50 17 = 36dc 18 = 600 60 20 = 480 50/60 21 = 6dc 22 = 32dc 24 = 277 60	-01 Thru -99	G = Customer Special  (Omit for Standard)	B1 = Bulk Pack  (Omit for Individual Pack)

### Solenoid coil valve series selection table

Valve series	Junction box	Conduit	Leads	Spades	Molded-din with connector
50RB	—	—	SML / RMF**	RMS	—
100RB / 200RB / 240RA	AMG / MMG*	AMC / MMC*	AMF	AMS	ASC2 / ASC2L
500RB	DMG	—	DMF	DMS	—
540RA	—	—	—	DMS	ASC2
202CB	AMG / AHG / MMG*	AMC / AHC MMC*	AMF / MMF*	AMS	ASC2 / ASC2L
203CA	AMG / AHG / MMG*	AMC / AHC MMC*	AMF / MMF*	AMS	ASC2 / ASC2L
204CD	AMG / AHG / MMG*	AMC / AHC MMC*	AMF / MMF*	AMS	ASC2 / ASC2L
210CA	AMG / MMG*	AMC / MMC*	AMF / MMF*	AMS	ASC2 / ASC2L
211CA	AMG / MMG*	AMC / MMC*	AMF / MMF*	AMS	ASC2 / ASC2L
222CB	AMG / AHG / MMG*	AMC / AHC MMC*	AMF / MMF*	AMS	ASC2 / ASC2L
214CB	AMG / AHG / MMG*	AMC / AHC MMC*	AMF / MMF*	AMS	ASC2 / ASC2L
314UB	AMG / MMG*	AMC / MMC*	AMF / MMF*	AMS	ASC2 / ASC2L

\* Special DC Application  
\*\* SML if for OEM, RMF is for wholesale replacement.

Detailed product drawings



## Coils for solenoid valves

Coil series	Voltage	Watts 50/60 hz	Enclosure type	Leads	Model number	Item number
AHC	120 50/60	17/12	Conduit	18"	AHC 2-01	057743
AHG	24 50/60	17/12	Junction Box	6"	AHG 1-01	057669
	120 50/60	17/12	Junction Box	6"	AHG 2-01	057673
	208-220 50, 208-240 60	17/12	Junction Box	6"	AHG 3-01	057671
	12dc	15	Conduit	18"	AMC 5-01	057596
AMC	24dc	15	Conduit	18"	AMC 6-01	057633
	24 50/60	17/12	Conduit	18"	AMC 1-01	057631
	120 50/60	17/12	Conduit	18"	AMC 2-01	057598
	120-240 50/60	17/12	Conduit	18"	AMC 4-01	057730
	208-220/50, 208-240/60	17/12	Conduit	18"	AMC 3-01	057594
	24 50/60	17/12	Open Frame	18"	AMF 1-01	057539
AMF	24 50/60	17/12	Open Frame	36"	AMF 1-02	057538
	120 50/60	17/12	Open Frame	18"	AMF 2-01	057546
	208-220 50, 208-240 60	17/12	Open Frame	18"	AMF 3-01	057540
	480 50/60	17/12	Open Frame	18"	AMF 20-01	057534
	12dc	15	Junction Box	6"	AMG 5-01	057521
AMG	24dc	15	Junction Box	6"	AMG 6-01	057523
	24 50/60	17/12	Junction Box	6"	AMG 1-01	057341
	120 50/60	17/12	Junction Box	6"	AMG 2-01	057331
	120-240 50/60	17/12	Junction Box	6"	AMG 4-01	057343
	208-220 50, 208-240 60	17/12	Junction Box	6"	AMG 3-01	057342
	277 60	17/12	Junction Box	6"	AMG 24-01	057528
	480 50/60	17/12	Junction Box	6"	AMG 20-01	057527
	24 50/60	17/12	Spade	—	AMS 1-01	057603
AMS	120 50/60	17/12	Spade	—	AMS 2-01	057349
	208-220 50, 208-240 60	17/12	Spade	—	AMS 3-01	057531
	24dc	15	Din	—	ASC2 6-01	064375
ASC2	24 50/60	17/12	Din	—	ASC2 1-01	062792
	120 50/60	17/12	Din	—	ASC2 2-01	062462
	120 50/60	17/12	Din	—	ASC2 2-02G	015384
	208-220 50, 208-240 60	17/12	Din	—	ASC2 3-01	062463
	208-240/50, 208-240/60	17/12	Din	—	ASC2 10-01	015383
	24 50/60	17/12	Leads	—	ASC2L 1-01	063542
	24/60	17/12	Din	—	ASC2X 1-01	064503
	24 50/60	10/10	Junction Box	6"	DMG 1-01	055129
DMG	120 50/60	10/10	Junction Box	6"	DMG 2-01	054762
	208-220 50, 208-240 60	10/10	Junction Box	6"	DMG 3-01	054764
	12dc	4	Open Frame	18"	MMF 5-01	062972
MMF	12dc	4	Junction Box	18"	MMG 5-01	063524
	24dc	4	Junction Box	18"	MMG 6-01	063526
MMG	120 50/60	7	Open Frame Lead	—	RMF 2-01	065678
RMF	24 50/60	7	Spade	—	RMS 1-01	065680
	120 50/60	7	Spade	—	RMS 2-01	065204
	208-220 50, 208-240 60	7	Spade	—	RMS 3-01	065681

# Refrigerant solenoid capacity tables

## Liquid capacities - tons

Pressure drop across valve - psi				
Valve series	2	3	4	5
<b>R-12</b>				
50RB	0.34	0.42	0.48	0.54
100RB	0.80	1.00	1.16	1.20
150RB 1	0.80	1.00	1.16	1.20
150RB 3	2.28	2.80	3.23	3.61
150RB 7	3.04	3.72	4.30	4.80
150RB 9	4.95	6.17	7.12	7.97
200RB/500RB 2	2.28	2.80	3.23	3.61
200RB/500RB 3	3.04	3.72	4.30	4.80
200RB/500RB 4	4.95	6.17	7.12	7.97
200RB/500RB 5	5.20	6.38	7.37	8.24
200RB/500RB 6	6.01	7.36	8.50	9.50
200RB/500RB 7	10.75	13.05	15.10	17.05
240RA/250RA/540RA 8	10.00	12.20	14.10	15.80
240RA/250RA/540RA 9T (5/8)	14.90	18.20	21.10	23.60
240RA/250RA/540RA 9T (7/8 & Up)	19.60	24.00	27.70	31.00
240RA/250RA/540RA 12	22.50	27.60	31.80	35.60
240RA/250RA/540RA 16	10.00	12.20	14.10	15.80
240RA/250RA/540RA 20	14.90	18.20	21.10	23.60
<b>R-1234YF</b>				
100RB	0.72	0.88	1.01	1.13
150RB 1	0.72	0.88	1.01	1.13
150RB 3	2.03	2.49	2.88	3.22
150RB 7	2.71	3.32	3.84	4.29
150RB 9	4.49	5.50	6.35	7.10
200RB/500RB 2	2.03	2.49	2.88	3.22
200RB/500RB 3	2.71	3.32	3.84	4.29
200RB/500RB 4	4.49	5.50	6.35	7.10
200RB/500RB 5	4.64	5.69	6.57	7.34
200RB/500RB 6	5.36	6.56	7.58	8.47
<b>R-134A</b>				
50RB	0.41	0.50	0.60	0.60
100RB	0.96	1.20	1.40	1.50
150RB 1	0.96	1.20	1.40	1.50
150RB 3	2.72	3.33	3.85	4.30
150RB 7	3.62	4.44	5.12	5.73
150RB 9	6.00	7.35	8.49	9.49
200RB/500RB 2	2.72	3.33	3.85	4.30
200RB/500RB 3	3.62	4.44	5.12	5.73
200RB/500RB 4	6.00	7.35	8.49	9.49
200RB/500RB 5	6.21	7.60	8.78	9.82
200RB/500RB 6	7.16	8.77	10.13	11.32
200RB/500RB 7	12.68	15.93	18.39	20.56
240RA/250RA/540RA 8	12.10	14.80	17.10	19.10
240RA/250RA/540RA 9T (5/8)	18.00	22.00	25.50	28.50
240RA/250RA/540RA 9T (7/8 & Up)	23.60	28.90	33.40	37.30
240RA/250RA/540RA 12	27.10	33.20	38.30	42.80
240RA/250RA/540RA 16	45.00	55.10	63.60	71.20
240RA/250RA/540RA 20	70.90	86.80	100.30	112.10

## Liquid capacities - kw

Pressure drop across valve - kpa				
Valve series	13.8	20.7	27.6	34.5
<b>R-12</b>				
50RB	1.20	1.48	1.69	1.90
100RB	2.81	3.52	4.08	4.22
150RB 1	2.81	3.52	4.08	4.22
150RB 3	8.02	9.85	11.36	12.70
150RB 7	10.69	13.08	15.12	16.88
150RB 9	17.41	21.70	25.04	28.03
200RB/500RB 2	8.02	9.85	11.36	12.70
200RB/500RB 3	10.69	13.08	15.12	16.88
200RB/500RB 4	17.41	21.70	25.04	28.03
200RB/500RB 5	18.29	22.44	25.92	28.98
200RB/500RB 6	21.14	25.88	29.89	33.41
200RB/500RB 7	37.81	45.90	53.11	59.96
240RA/250RA/540RA 8	35.17	42.91	49.59	55.57
240RA/250RA/540RA 9T (5/8)	52.40	64.01	74.21	83.00
240RA/250RA/540RA 9T (7/8 & Up)	68.93	84.41	97.42	109.02
240RA/250RA/540RA 12	79.13	97.07	111.84	125.20
240RA/250RA/540RA 16	35.17	42.91	49.59	55.57
240RA/250RA/540RA 20	52.40	64.01	74.21	83.00
<b>R-1234YF</b>				
100RB	2.52	3.09	3.57	3.99
150RB 1	2.52	3.09	3.57	3.99
150RB 3	7.15	8.76	10.12	11.31
150RB 7	9.54	11.68	13.49	15.08
150RB 9	15.80	19.35	22.34	24.98
200RB/500RB 2	7.15	8.76	10.12	11.31
200RB/500RB 3	9.54	11.68	13.49	15.08
200RB/500RB 4	15.80	19.35	22.34	24.98
200RB/500RB 5	16.34	20.01	23.10	25.83
200RB/500RB 6	18.84	23.07	26.64	29.79
<b>R-134A</b>				
50RB	1.44	1.76	2.11	2.11
100RB	3.38	4.22	4.92	5.28
150RB 1	3.38	4.22	4.92	5.28
150RB 3	9.57	11.71	13.54	15.12
150RB 7	12.73	15.62	18.01	20.15
150RB 9	21.10	25.85	29.86	33.38
200RB/500RB 2	9.57	11.71	13.54	15.12
200RB/500RB 3	12.73	15.62	18.01	20.15
200RB/500RB 4	21.10	25.85	29.86	33.38
200RB/500RB 5	21.84	26.73	30.88	34.54
200RB/500RB 6	25.18	30.84	35.63	39.81
200RB/500RB 7	44.59	56.02	64.68	72.31
240RA/250RA/540RA 8	42.55	52.05	60.14	67.17
240RA/250RA/540RA 9T (5/8)	63.30	77.37	89.68	100.23
240RA/250RA/540RA 9T (7/8 & Up)	83.00	101.64	117.46	131.18
240RA/250RA/540RA 12	95.31	116.76	134.70	150.52
240RA/250RA/540RA 16	158.26	193.78	223.67	250.40
240RA/250RA/540RA 20	249.35	305.27	352.75	394.24

**Note:** Shading indicates AHRI standard ratings

All liquid capacities are based on 40°F Evaporator Temperature and 100°F Liquid Temperature.

**Note:** Capacity is based on largest connection size.

Liquid capacities - tons

Pressure drop across valve - psi				
Valve series	2	3	4	5
<b>R-22</b>				
50RB	0.44	0.54	0.62	0.69
100RB	1.04	1.27	1.47	1.64
150RB 1	1.04	1.27	1.47	1.64
150RB 3	2.94	3.60	4.16	4.65
150RB 7	3.92	4.80	5.54	6.19
150RB 9	6.49	7.95	9.18	10.26
200RB/500RB 2	2.94	3.60	4.16	4.65
200RB/500RB 3	3.92	4.80	5.54	6.19
200RB/500RB 4	6.49	7.95	9.18	10.26
200RB/500RB 5	6.71	8.22	9.49	10.61
200RB/500RB 6	7.74	9.48	10.95	12.24
200RB/500RB 7	13.50	17.00	18.75	27.85
240RA/250RA/540RA 8	12.70	15.60	18.00	20.10
240RA/250RA/540RA 9T (5/8)	19.00	23.30	26.90	30.10
240RA/250RA/540RA 9T (7/8 & Up)	24.90	30.50	35.20	39.40
240RA/250RA/540RA 12	28.50	34.90	40.30	45.10
240RA/250RA/540RA 16	47.40	58.00	67.00	74.90
240RA/250RA/540RA 20	77.90	95.40	110.20	123.20
<b>R-290</b>				
50RB	0.46	0.56	0.65	0.73
100RB	1.08	1.32	1.53	1.71
150RB 1	1.08	1.32	1.53	1.71
150RB 3	3.06	3.75	4.33	4.84
150RB 7	4.08	5.00	5.78	6.46
150RB 9	6.76	8.25	9.57	10.69
200RB/500RB 2	3.06	3.75	4.33	4.84
200RB/500RB 3	4.08	5.00	5.78	6.46
200RB/500RB 4	6.76	8.25	9.57	10.69
200RB/500RB 5	6.99	8.57	9.89	11.06
200RB/500RB 6	8.07	9.88	11.41	12.75
<b>R-32</b>				
100RB	1.41	1.73	2.00	2.23
150RB 1	1.41	1.73	2.00	2.23
150RB 3	4.00	4.90	5.66	6.32
150RB 7	5.33	6.53	7.53	8.42
150RB 9	8.83	10.81	12.48	13.95
200RB/500RB 2	4.00	4.90	5.66	6.32
200RB/500RB 3	5.33	6.53	7.53	8.42
200RB/500RB 4	8.83	10.81	12.48	13.95
200RB/500RB 5	9.13	11.18	12.91	14.43
200RB/500RB 6	10.53	12.89	14.89	16.65
250RA 8	17.27	21.22	24.48	27.34
250RA 9T (5/8)	25.84	31.69	36.58	40.94
250RA 9T (7/8 & Up)	33.86	41.48	47.87	53.58
250RA 12	38.76	47.46	54.81	61.34
250RA 16	64.46	78.88	91.12	101.86
250RA 20	105.94	129.74	149.87	167.55

Liquid capacities - kw

Pressure drop across valve - kpa				
Valve series	13.8	20.7	27.6	34.5
<b>R-22</b>				
50RB	1.55	1.90	2.18	2.43
100RB	3.66	4.47	5.17	5.77
150RB 1	3.66	4.47	5.17	5.77
150RB 3	10.34	12.66	14.63	16.35
150RB 7	13.79	16.88	19.48	21.77
150RB 9	22.82	27.96	32.29	36.08
200RB/500RB 2	10.34	12.66	14.63	16.35
200RB/500RB 3	13.79	16.88	19.48	21.77
200RB/500RB 4	22.82	27.96	32.29	36.08
200RB/500RB 5	23.60	28.91	33.38	37.31
200RB/500RB 6	27.22	33.34	38.51	43.05
200RB/500RB 7	47.48	59.79	65.94	97.95
240RA/250RA/540RA 8	44.66	54.86	63.30	70.69
240RA/250RA/540RA 9T (5/8)	66.82	81.94	94.60	105.86
240RA/250RA/540RA 9T (7/8 & Up)	87.57	107.27	123.79	138.57
240RA/250RA/540RA 12	100.23	122.74	141.73	158.61
240RA/250RA/540RA 16	166.70	203.98	235.63	263.42
240RA/250RA/540RA 20	273.97	335.51	387.56	433.28
<b>R-290</b>				
50RB	1.62	1.97	2.29	2.57
100RB	3.80	4.64	5.38	6.01
150RB 1	3.80	4.64	5.38	6.01
150RB 3	10.76	13.19	15.23	17.02
150RB 7	14.35	17.58	20.33	22.72
150RB 9	23.77	29.12	33.66	37.60
200RB/500RB 2	10.76	13.19	15.23	17.02
200RB/500RB 3	14.35	17.58	20.33	22.72
200RB/500RB 4	23.77	29.12	33.66	37.60
200RB/500RB 5	24.58	30.14	34.78	38.90
200RB/500RB 6	28.38	34.75	40.13	44.84
<b>R-32</b>				
100RB	4.97	6.07	7.03	7.84
150RB 1	4.97	6.07	7.03	7.84
150RB 3	14.06	17.22	19.90	22.24
150RB 7	18.75	22.96	26.50	29.61
150RB 9	31.04	38.02	43.91	49.07
200RB/500RB 2	14.06	17.22	19.90	22.24
200RB/500RB 3	18.75	22.96	26.50	29.61
200RB/500RB 4	31.04	38.02	43.91	49.07
200RB/500RB 5	32.09	39.32	45.39	50.75
200RB/500RB 6	37.02	45.34	52.37	58.54
250RA 8	60.74	74.61	86.09	96.14
250RA 9T (5/8)	90.88	111.44	128.66	143.97
250RA 9T (7/8 & Up)	119.09	145.88	168.36	188.45
250RA 12	136.31	166.92	192.75	215.71
250RA 16	226.71	277.41	320.46	358.24
250RA 20	372.59	456.29	527.08	589.26

**Note:** Shading indicates AHRI standard ratings  
 All liquid capacities are based on 40°F Evaporator Temperature and 100°F Liquid Temperature.  
**Note:** Capacity is based on largest connection size.

Liquid capacities - tons

Pressure drop across valve - psi				
Valve series	2	3	4	5
<b>R-404A/R-507</b>				
50RB	0.30	0.34	0.40	0.40
100RB	0.70	0.85	1.00	1.10
150RB 1	0.70	0.85	1.00	1.10
150RB 3	1.90	2.32	2.68	3.00
150RB 7	2.52	3.09	3.57	4.00
150RB 9	4.18	5.12	5.92	6.61
200RB/500RB 2	1.90	2.32	2.68	3.00
200RB/500RB 3	2.52	3.09	3.57	4.00
200RB/500RB 4	4.18	5.12	5.92	6.61
200RB/500RB 5	4.33	5.30	6.12	6.84
200RB/500RB 6	4.99	6.11	7.06	7.89
200RB/500RB 7	9.06	11.10	12.81	14.33
240RA/250RA/540RA 8	8.40	10.30	11.90	13.30
240RA/250RA/540RA 9T (5/8)	12.50	15.30	17.70	19.80
240RA/250RA/540RA 9T (7/8 & Up)	16.40	20.10	23.20	25.90
240RA/250RA/540RA 12	18.80	23.00	26.60	29.70
240RA/250RA/540RA 16	31.30	38.30	44.20	49.40
240RA/250RA/540RA 20	53.60	65.70	75.90	84.80
<b>R-407C</b>				
50RB	0.40	0.51	0.60	0.70
100RB	1.00	1.21	1.40	1.60
150RB 1	1.00	1.21	1.40	1.60
150RB 3	2.77	3.39	3.91	4.38
150RB 7	3.68	4.51	5.21	5.82
150RB 9	6.11	7.48	8.64	9.66
200RB/500RB 2	2.77	3.39	3.91	4.38
200RB/500RB 3	3.68	4.51	5.21	5.82
200RB/500RB 4	6.11	7.48	8.64	9.66
200RB/500RB 5	6.31	7.73	8.93	9.98
200RB/500RB 6	7.28	8.92	10.30	11.52
200RB/500RB 7	13.10	16.15	18.65	20.65
240RA/250RA/540RA 8	12.10	14.80	17.10	19.10
240RA/250RA/540RA 9T (5/8)	18.00	22.10	25.50	28.50
240RA/250RA/540RA 9T (7/8 & Up)	23.70	29.00	33.50	37.40
240RA/250RA/540RA 12	27.10	33.20	38.30	42.90
240RA/250RA/540RA 16	45.10	55.20	63.70	71.30
240RA/250RA/540RA 20	74.10	90.80	104.80	117.20
<b>R-410A</b>				
100RB	0.97	1.19	1.37	1.53
150RB 1	0.97	1.19	1.37	1.53
150RB 3	2.76	3.38	3.90	4.36
150RB 7	3.67	4.50	5.19	5.80
150RB 9	6.09	7.45	8.61	9.62
200RB/500RB 2	2.76	3.38	3.90	4.36
200RB/500RB 3	3.67	4.50	5.19	5.80
200RB/500RB 4	6.09	7.45	8.61	9.62
200RB/500RB 5	6.29	7.71	8.90	9.95
200RB/500RB 6	7.26	8.89	10.27	11.48
200RB/500RB 7	12.20	15.70	18.10	20.10
250RA 8	11.86	14.57	16.81	18.77
250RA 9T (5/8)	17.75	21.76	25.12	28.11
250RA 9T (7/8 & Up)	23.26	28.49	32.88	36.80
250RA 12	26.62	32.60	37.64	42.12
250RA 16	44.27	54.17	62.58	69.96
250RA 20	72.76	89.10	102.93	115.07

Liquid capacities - kw

Pressure drop across valve - kpa				
Valve series	13.8	20.7	27.6	34.5
<b>R-404A/R-507</b>				
50RB	1.06	1.20	1.41	1.41
100RB	2.46	2.99	3.52	3.87
150RB 1	2.46	2.99	3.52	3.87
150RB 3	6.68	8.16	9.43	10.55
150RB 7	8.86	10.87	12.56	14.07
150RB 9	14.70	18.01	20.82	23.25
200RB/500RB 2	6.68	8.16	9.43	10.55
200RB/500RB 3	8.86	10.87	12.56	14.07
200RB/500RB 4	14.70	18.01	20.82	23.25
200RB/500RB 5	15.23	18.64	21.52	24.06
200RB/500RB 6	17.55	21.49	24.83	27.75
200RB/500RB 7	31.86	39.04	45.05	50.40
240RA/250RA/540RA 8	29.54	36.22	41.85	46.77
240RA/250RA/540RA 9T (5/8)	43.96	53.81	62.25	69.63
240RA/250RA/540RA 9T (7/8 & Up)	57.68	70.69	81.59	91.09
240RA/250RA/540RA 12	66.12	80.89	93.55	104.45
240RA/250RA/540RA 16	110.08	134.70	155.45	173.73
240RA/250RA/540RA 20	188.51	231.06	266.93	298.23
<b>R-407C</b>				
50RB	1.41	1.79	2.11	2.46
100RB	3.52	4.26	4.92	5.63
150RB 1	3.52	4.26	4.92	5.63
150RB 3	9.74	11.92	13.75	15.40
150RB 7	12.94	15.86	18.32	20.47
150RB 9	21.49	26.31	30.39	33.97
200RB/500RB 2	9.74	11.92	13.75	15.40
200RB/500RB 3	12.94	15.86	18.32	20.47
200RB/500RB 4	21.49	26.31	30.39	33.97
200RB/500RB 5	22.19	27.19	31.41	35.10
200RB/500RB 6	25.60	31.37	36.22	40.51
200RB/500RB 7	46.53	56.97	65.80	73.54
240RA/250RA/540RA 8	42.55	52.05	60.14	67.17
240RA/250RA/540RA 9T (5/8)	63.30	77.72	89.68	100.23
240RA/250RA/540RA 9T (7/8 & Up)	83.35	101.99	117.82	131.53
240RA/250RA/540RA 12	95.31	116.76	134.70	150.88
240RA/250RA/540RA 16	158.61	194.13	224.03	250.75
240RA/250RA/540RA 20	260.60	319.33	368.57	412.18
<b>R-410A</b>				
100RB	3.42	4.17	4.83	5.39
150RB 1	3.42	4.17	4.83	5.39
150RB 3	9.71	11.89	13.72	15.33
150RB 7	12.91	15.83	18.25	20.4
150RB 9	21.42	26.2	30.28	33.83
200RB/500RB 2	9.71	11.89	13.72	15.33
200RB/500RB 3	12.91	15.83	18.25	20.4
200RB/500RB 4	21.42	26.2	30.28	33.83
200RB/500RB 5	22.12	27.12	31.3	34.99
200RB/500RB 6	25.53	31.27	36.12	40.37
200RB/500RB 7	42.91	55.22	63.66	70.69
250RA 8	41.72	51.24	59.13	66.02
250RA 9T (5/8)	62.41	76.53	88.36	98.87
250RA 9T (7/8 & Up)	81.79	100.18	115.62	129.42
250RA 12	93.62	114.64	132.37	148.14
250RA 16	155.70	190.51	220.08	246.03
250RA 20	255.88	313.36	361.98	404.68

Note: Shading indicates AHRI standard ratings  
 All liquid capacities are based on 40°F Evaporator Temperature and 100°F Liquid Temperature.  
 Note: Capacity is based on largest connection size.

Liquid capacities - tons

Pressure drop across valve - psi				
Valve series	2	3	4	5
<b>R-448A/R-449A</b>				
50RB	0.44	0.54	0.63	0.70
100RB	1.04	1.28	1.47	1.65
150RB 1	1.04	1.28	1.47	1.65
150RB 3	2.95	3.61	4.17	4.67
150RB 7	3.93	4.82	5.56	6.22
150RB 9	6.52	7.98	9.22	10.30
200RB/500RB 2	2.95	3.61	4.17	4.67
200RB/500RB 3	3.93	4.82	5.56	6.22
200RB/500RB 4	6.52	7.98	9.22	10.30
200RB/500RB 5	6.74	8.25	9.53	10.65
200RB/500RB 6	7.77	9.52	10.99	12.29
200RB/500RB 7	13.94	17.07	19.71	22.03
240RA/250RA/540RA 8	12.79	15.66	18.09	20.22
240RA/250RA/540RA 9T (5/8)	19.10	23.39	27.01	30.20
240RA/250RA/540RA 9T (7/8 & Up)	25.00	30.62	35.36	39.53
240RA/250RA/540RA 12	28.61	35.04	40.46	45.24
240RA/250RA/540RA 16	47.55	58.23	67.24	75.18
240RA/250RA/540RA 20	78.20	95.78	110.60	123.65
<b>R-454A</b>				
100RB	1.18	1.44	1.67	1.86
150RB 1	1.18	1.44	1.67	1.86
150RB 3	3.34	4.09	4.73	5.29
150RB 7	4.46	5.46	6.30	7.05
150RB 9	7.38	9.04	10.44	11.67
200RB/500RB 2	3.34	4.09	4.73	5.29
200RB/500RB 3	4.46	5.46	6.30	7.05
200RB/500RB 4	7.38	9.04	10.44	11.67
200RB/500RB 5	7.63	9.35	10.80	12.07
200RB/500RB 6	8.80	10.78	12.45	13.92
250RA/540RA 8	14.49	17.74	20.49	22.91
250RA/540RA 9T (5/8)	21.64	26.50	30.60	34.21
250RA/540RA 9T (7/8 & Up)	28.32	34.69	40.05	44.78
250RA/540RA 12	32.41	39.69	45.83	51.24
250RA/540RA 16	53.86	65.97	76.17	85.16
250RA/540RA 20	88.59	108.50	125.29	140.07
<b>R-454B/R-452B</b>				
100RB	0.94	1.15	1.33	1.48
150RB 1	0.94	1.15	1.33	1.48
150RB 3	2.66	3.25	3.76	4.20
150RB 7	3.54	4.34	5.01	5.59
150RB 9	5.86	7.18	8.29	9.27
200RB/500RB 2	2.66	3.25	3.76	4.20
200RB/500RB 3	3.54	4.34	5.01	5.59
200RB/500RB 4	5.86	7.18	8.29	9.27
200RB/500RB 5	6.06	7.43	8.57	9.59
200RB/500RB 6	6.99	8.57	9.89	11.06
250RA 8	11.47	14.09	16.26	18.16
250RA 9T (5/8)	17.17	21.05	24.30	27.20
250RA 9T (7/8 & Up)	22.50	27.56	31.80	35.60
250RA 12	25.75	31.53	36.41	40.75
250RA 16	42.83	52.40	60.53	67.67
250RA 20	70.38	86.19	99.57	111.31
<b>R-454C</b>				
100RB	0.99	1.21	1.39	1.56
150RB 1	0.99	1.21	1.39	1.56
150RB 3	2.80	3.42	3.95	4.42
150RB 7	3.73	4.57	5.27	5.89
150RB 9	6.17	7.56	8.73	9.76
200RB/500RB 2	2.80	3.42	3.95	4.42
200RB/500RB 3	3.73	4.57	5.27	5.89
200RB/500RB 4	6.17	7.56	8.73	9.76
200RB/500RB 5	6.38	7.82	9.03	10.09
200RB/500RB 6	7.36	9.02	10.41	11.64

Liquid capacities - kw

Pressure drop across valve - kpa				
Valve series	13.8	20.7	27.6	34.5
<b>R-448A/R-449A</b>				
50RB	1.56	1.91	2.20	2.46
100RB	3.66	4.48	5.18	5.79
150RB 1	3.66	4.48	5.18	5.79
150RB 3	10.38	12.71	14.68	16.41
150RB 7	13.84	16.95	19.57	21.88
150RB 9	22.92	28.07	32.41	36.24
200RB/500RB 2	10.38	12.71	14.68	16.41
200RB/500RB 3	13.84	16.95	19.57	21.88
200RB/500RB 4	22.92	28.07	32.41	36.24
200RB/500RB 5	23.70	29.02	33.51	37.47
200RB/500RB 6	27.33	33.47	38.65	43.21
200RB/500RB 7	49.01	60.02	69.31	77.49
240RA/250RA/540RA 8	44.97	55.08	63.60	71.11
240RA/250RA/540RA 9T (5/8)	67.17	82.27	95.00	106.21
240RA/250RA/540RA 9T (7/8 & Up)	87.93	107.69	124.35	139.03
240RA/250RA/540RA 12	100.61	123.23	142.29	159.08
240RA/250RA/540RA 16	167.21	204.79	236.47	264.38
240RA/250RA/540RA 20	275.03	336.84	388.95	434.86
<b>R-454A</b>				
100RB	4.15	5.08	5.87	6.56
150RB 1	4.15	5.08	5.87	6.56
150RB 3	11.76	14.40	16.63	18.59
150RB 7	15.68	19.20	22.17	24.79
150RB 9	25.96	31.80	36.72	41.05
200RB/500RB 2	11.76	14.40	16.63	18.59
200RB/500RB 3	15.68	19.20	22.17	24.79
200RB/500RB 4	25.96	31.80	36.72	41.05
200RB/500RB 5	26.85	32.88	37.97	42.45
200RB/500RB 6	30.96	37.92	43.79	48.95
250RA/540RA 8	50.95	62.40	72.05	80.56
250RA/540RA 9T (5/8)	76.10	93.20	107.62	120.32
250RA/540RA 9T (7/8 & Up)	99.61	122.00	140.87	157.50
250RA/540RA 12	113.98	139.60	161.20	180.22
250RA/540RA 16	189.43	232.00	267.89	299.51
250RA/540RA 20	311.57	381.60	440.63	492.64
<b>R-454B/R-452B</b>				
100RB	3.30	4.04	4.67	5.21
150RB 1	3.30	4.04	4.67	5.21
150RB 3	9.34	11.44	13.22	14.78
150RB 7	12.46	15.25	17.60	19.67
150RB 9	20.62	25.26	29.17	32.60
200RB/500RB 2	9.34	11.44	13.22	14.78
200RB/500RB 3	12.46	15.25	17.60	19.67
200RB/500RB 4	20.62	25.26	29.17	32.60
200RB/500RB 5	21.32	26.12	30.15	33.71
200RB/500RB 6	24.59	30.12	34.79	38.89
250RA 8	40.35	49.57	57.19	63.87
250RA 9T (5/8)	60.37	74.04	85.47	95.64
250RA 9T (7/8 & Up)	79.12	96.91	111.85	125.19
250RA 12	90.56	110.89	128.05	143.30
250RA 16	150.61	184.29	212.89	237.99
250RA 20	247.53	303.13	350.16	391.46
<b>R-454C</b>				
100RB	3.47	4.25	4.91	5.48
150RB 1	3.47	4.25	4.91	5.48
150RB 3	9.83	12.04	13.91	15.55
150RB 7	13.11	16.06	18.54	20.73
150RB 9	21.71	26.59	30.71	34.33
200RB/500RB 2	9.83	12.04	13.91	15.55
200RB/500RB 3	13.11	16.06	18.54	20.73
200RB/500RB 4	21.71	26.59	30.71	34.33
200RB/500RB 5	22.45	27.50	31.75	35.50
200RB/500RB 6	25.89	31.71	36.62	40.94

Note: Shading indicates AHRI standard ratings  
 All liquid capacities are based on 40°F Evaporator Temperature and 100°F Liquid Temperature.  
 Note: Capacity is based on largest connection size.

Liquid capacities - tons

Pressure drop across valve - psi				
Valve series	2	3	4	5
<b>R-455A</b>				
100RB	1.03	1.27	1.46	1.63
150RB 1	1.03	1.27	1.46	1.63
150RB 3	2.93	3.59	4.14	4.63
150RB 7	3.91	4.78	5.52	6.18
150RB 9	6.47	7.92	9.15	10.23
200RB/500RB 2	2.93	3.59	4.14	4.63
200RB/500RB 3	3.91	4.78	5.52	6.18
200RB/500RB 4	6.47	7.92	9.15	10.23
200RB/500RB 5	6.69	8.19	9.46	10.58
200RB/500RB 6	7.71	9.45	10.91	12.20
250RA/540RA 8	12.69	15.55	17.95	20.07
250RA/540RA 9T (5/8)	18.96	23.22	26.81	29.98
250RA/540RA 9T (7/8 & Up)	24.82	30.40	35.10	39.24
250RA/540RA 12	28.40	34.78	40.16	44.91
250RA/540RA 16	47.20	57.81	66.75	74.63
250RA/540RA 20	77.63	95.08	109.79	122.75
<b>R-502</b>				
50RB	0.30	0.35	0.40	0.50
100RB	0.70	0.83	1.00	1.10
150RB 1	0.70	0.83	1.00	1.10
150RB 3	1.93	2.36	2.73	3.05
150RB 7	2.57	3.14	3.63	4.06
150RB 9	4.15	5.21	6.02	6.73
200RB/500RB 2	1.93	2.36	2.73	3.05
200RB/500RB 3	2.57	3.14	3.63	4.06
200RB/500RB 4	4.15	5.21	6.02	6.73
200RB/500RB 5	4.50	5.39	6.22	6.69
200RB/500RB 6	5.08	6.22	7.18	8.03
200RB/500RB 7	9.22	11.29	13.04	14.57
240RA/250RA/540RA 8	8.20	10.10	11.70	13.00
240RA/250RA/540RA 9T (5/8)	12.30	15.10	17.40	19.50
240RA/250RA/540RA 9T (7/8 & Up)	16.20	19.80	22.90	25.60
240RA/250RA/540RA 12	18.50	22.70	26.20	29.30
240RA/250RA/540RA 16	30.80	37.70	43.50	48.70
240RA/250RA/540RA 20	50.60	62.00	71.60	80.00
<b>R-513A/R-450A</b>				
50RB	0.37	0.46	0.53	0.59
100RB	0.88	1.07	1.24	1.38
150RB 1	0.88	1.07	1.24	1.38
150RB 3	2.48	3.04	3.51	3.92
150RB 7	3.31	4.05	4.68	5.23
150RB 9	5.48	6.71	7.75	8.67
200RB/500RB 2	2.48	3.04	3.51	3.92
200RB/500RB 3	3.31	4.05	4.68	5.23
200RB/500RB 4	5.48	6.71	7.75	8.67
200RB/500RB 5	5.67	6.94	8.02	8.96
200RB/500RB 6	6.54	8.01	9.24	10.34
200RB/500RB 7	11.72	14.36	16.58	18.53
240RA/250RA/540RA 8	10.76	13.17	15.21	17.01
240RA/250RA/540RA 9T (5/8)	16.07	19.68	22.72	25.40
240RA/250RA/540RA 9T (7/8 & Up)	21.03	25.76	29.74	33.25
240RA/250RA/540RA 12	24.06	29.47	34.03	38.05
240RA/250RA/540RA 16	39.99	48.98	56.56	63.23
240RA/250RA/540RA 20	65.78	80.56	93.02	104.00

Liquid capacities - kw

Pressure drop across valve - kpa				
Valve series	13.8	20.7	27.6	34.5
<b>R-455A</b>				
100RB	3.63	4.45	5.14	5.75
150RB 1	3.63	4.45	5.14	5.75
150RB 3	10.30	12.62	14.57	16.29
150RB 7	13.74	16.83	19.43	21.72
150RB 9	22.75	27.87	32.18	35.98
200RB/500RB 2	10.30	12.62	14.57	16.29
200RB/500RB 3	13.74	16.83	19.43	21.72
200RB/500RB 4	22.75	27.87	32.18	35.98
200RB/500RB 5	23.53	28.81	33.27	37.20
200RB/500RB 6	27.13	33.23	38.37	42.90
250RA/540RA 8	44.65	54.68	63.14	70.59
250RA/540RA 9T (5/8)	66.69	81.67	94.31	105.44
250RA/540RA 9T (7/8 & Up)	87.29	106.91	123.45	138.02
250RA/540RA 12	99.88	122.33	141.26	157.93
250RA/540RA 16	166.00	203.30	234.76	262.46
250RA/540RA 20	273.04	334.40	386.13	431.71
<b>R-502</b>				
50RB	1.06	1.23	1.41	1.76
100RB	2.46	2.92	3.52	3.87
150RB 1	2.46	2.92	3.52	3.87
150RB 3	6.79	8.30	9.60	10.73
150RB 7	9.04	11.04	12.77	14.28
150RB 9	14.60	18.32	21.17	23.67
200RB/500RB 2	6.79	8.30	9.60	10.73
200RB/500RB 3	9.04	11.04	12.77	14.28
200RB/500RB 4	14.60	18.32	21.17	23.67
200RB/500RB 5	15.83	18.96	21.88	23.53
200RB/500RB 6	17.87	21.88	25.25	28.24
200RB/500RB 7	32.43	39.71	45.86	51.24
240RA/250RA/540RA 8	28.84	35.52	41.15	45.72
240RA/250RA/540RA 9T (5/8)	43.26	53.11	61.19	68.58
240RA/250RA/540RA 9T (7/8 & Up)	56.97	69.63	80.54	90.03
240RA/250RA/540RA 12	65.06	79.83	92.14	103.05
240RA/250RA/540RA 16	108.32	132.59	152.99	171.27
240RA/250RA/540RA 20	177.96	218.05	251.81	281.35
<b>R-513A/R-450A</b>				
50RB	1.31	1.60	1.85	2.07
100RB	3.08	3.77	4.36	4.87
150RB 1	3.08	3.77	4.36	4.87
150RB 3	8.73	10.69	12.35	13.80
150RB 7	11.64	14.26	16.46	18.40
150RB 9	19.28	23.61	27.26	30.48
200RB/500RB 2	8.73	10.69	12.35	13.80
200RB/500RB 3	11.64	14.26	16.46	18.40
200RB/500RB 4	19.28	23.61	27.26	30.48
200RB/500RB 5	19.93	24.41	28.19	31.52
200RB/500RB 6	22.99	28.15	32.51	36.35
200RB/500RB 7	41.22	50.49	58.30	65.18
240RA/250RA/540RA 8	37.83	46.33	53.50	59.81
240RA/250RA/540RA 9T (5/8)	56.50	69.20	79.90	89.33
240RA/250RA/540RA 9T (7/8 & Up)	73.96	90.58	104.59	116.94
240RA/250RA/540RA 12	84.63	103.65	119.68	133.81
240RA/250RA/540RA 16	140.64	172.25	198.90	222.37
240RA/250RA/540RA 20	231.33	283.32	327.15	365.76

**Note:** Shading indicates AHRI standard ratings  
 All liquid capacities are based on 40°F Evaporator Temperature and 100°F Liquid Temperature.  
**Note:** Capacity is based on largest connection size.

Liquid capacities - tons

Pressure drop across valve - psi						
Valve series	2	3	4	5	6	7
	R-744					
100RB	1.58	1.93	2.24	2.50	2.74	2.96
150RB 1	1.58	1.93	2.24	2.50	2.74	2.96
150RB 3	4.36	5.34	6.17	6.90	7.56	8.16
150RB 7	5.80	7.11	8.21	9.18	10.1	10.86
150RB 9	9.62	11.8	13.6	15.2	16.7	18.01
200RB/500RB 2	4.36	5.34	6.17	6.90	7.56	8.16
200RB/500RB 3	5.80	7.11	8.21	9.18	10.1	10.86
200RB/500RB 4	9.62	11.8	13.6	15.2	16.7	18.01
200RB/500RB 5	9.95	12.2	14.1	15.7	17.2	18.62
200RB/500RB 6	11.5	14.1	16.2	18.2	19.9	21.49
200RB/500RB 7	20.1	24.6	28.4	31.8	34.8	37.62

Liquid capacities - kw

Pressure drop across valve - kpa						
Valve series	13.8	20.7	27.6	34.5	41.4	48.3
	R-744					
100RB	5.56	6.81	7.86	8.79	9.63	10.40
150RB 1	5.56	6.81	7.86	8.79	9.63	10.40
150RB 3	15.34	18.79	21.70	24.26	26.57	28.70
150RB 7	20.41	25.00	28.86	32.27	35.35	38.18
150RB 9	33.85	41.46	47.87	53.52	58.63	63.33
200RB/500RB 2	15.34	18.79	21.70	24.26	26.57	28.70
200RB/500RB 3	20.41	25.00	28.86	32.27	35.35	38.18
200RB/500RB 4	33.85	41.46	47.87	53.52	58.63	63.33
200RB/500RB 5	35.01	42.88	49.51	55.36	60.64	65.50
200RB/500RB 6	40.40	49.47	57.13	63.87	69.97	75.57
200RB/500RB 7	70.73	86.62	100.02	111.83	122.50	132.32

**Note:** Shading indicates nominal ratings at 1°F saturation pressure drop across solenoid valve. All liquid capacities are based on 20°F evaporating temperature.

Suction gas capacities - tons

Suction gas capacities @ 2 psi pressure drop					
Valve series	Evaporator temperature - f				
	40	20	0	-20	-40
<b>R-12</b>					
100RB	0.13	0.12	0.09	0.07	0.04
150RB 1	0.13	0.12	0.09	0.07	0.04
150RB 3	0.32	0.30	0.23	0.17	0.10
150RB 7	0.44	0.41	0.31	0.23	0.14
150RB 9	0.81	0.77	0.59	0.44	0.26
200RB/500RB 2	0.32	0.30	0.23	0.17	0.10
200RB/500RB 3	0.44	0.41	0.31	0.23	0.14
200RB/500RB 4	0.81	0.77	0.59	0.44	0.26
200RB/500RB 5	0.97	0.93	0.71	0.53	0.32
200RB/500RB 6	1.05	0.99	0.76	0.56	0.34
200RB/500RB 7	1.90	1.70	1.30	1.00	0.60
240RA/250RA/540RA 8	1.00	0.80	0.60	0.50	0.40
240RA/250RA/540RA 9T5	1.30	1.10	0.90	0.70	0.50
240RA/250RA/540RA 9	1.60	1.30	1.00	0.80	0.60
240RA/250RA/540RA 12	2.00	1.60	1.20	1.00	0.70
240RA/250RA/540RA 16	3.90	3.20	2.50	1.90	1.50
240RA/250RA/540RA 20	5.50	4.50	3.50	2.70	2.10
<b>R-1234YF</b>					
100RB	0.09	0.07	0.06	0.04	0.03
150RB 1	0.09	0.07	0.06	0.04	0.03
150RB 3	0.23	0.18	0.14	0.10	0.08
150RB 7	0.32	0.25	0.19	0.14	0.10
150RB 9	0.60	0.47	0.36	0.27	0.20
200RB/500RB 2	0.23	0.18	0.14	0.10	0.08
200RB/500RB 3	0.32	0.25	0.19	0.14	0.10
200RB/500RB 4	0.60	0.47	0.36	0.27	0.20
200RB/500RB 5	0.73	0.58	0.44	0.33	0.24
200RB/500RB 6	0.77	0.61	0.47	0.35	0.25
<b>R-134A</b>					
100RB	0.10	0.08	0.06	0.04	0.03
150RB 1	0.10	0.08	0.06	0.04	0.03
150RB 3	0.26	0.21	0.16	0.11	0.08
150RB 7	0.36	0.29	0.21	0.15	0.10
150RB 9	0.69	0.54	0.42	0.28	0.16
200RB/500RB 2	0.26	0.21	0.16	0.11	0.08
200RB/500RB 3	0.36	0.29	0.21	0.15	0.10
200RB/500RB 4	0.69	0.54	0.42	0.28	0.16
200RB/500RB 5	0.83	0.65	0.47	0.34	0.23
200RB/500RB 6	0.88	0.69	0.52	0.37	0.26
200RB/500RB 7	1.50	1.20	0.90	0.70	0.50
240RA/250RA/540RA 8	0.80	0.60	0.50	0.40	0.30
240RA/250RA/540RA 9T5	1.40	1.10	0.80	0.60	0.40
240RA/250RA/540RA 9	1.70	1.40	1.10	0.80	0.50
240RA/250RA/540RA 12	1.90	1.50	1.20	0.90	0.60
240RA/250RA/540RA 16	3.20	2.50	1.90	1.40	1.00
240RA/250RA/540RA 20	4.40	3.50	2.70	2.00	1.60

Suction gas capacities - kw

Suction gas capacities @ 14.0 Kpa pressure drop					
Valve series	Evaporator temperature - c				
	4	-7	-18	-29	-40
<b>R-12</b>					
100RB	0.45	0.42	0.32	0.24	0.14
150RB 1	0.45	0.42	0.32	0.24	0.14
150RB 3	1.13	1.06	0.81	0.60	0.35
150RB 7	1.55	1.44	1.09	0.81	0.49
150RB 9	2.85	2.71	2.07	1.55	0.91
200RB/500RB 2	1.13	1.06	0.81	0.60	0.35
200RB/500RB 3	1.55	1.44	1.09	0.81	0.49
200RB/500RB 4	2.85	2.71	2.07	1.55	0.91
200RB/500RB 5	3.41	3.27	2.50	1.86	1.13
200RB/500RB 6	3.69	3.48	2.67	1.97	1.20
200RB/500RB 7	6.80	6.00	4.60	3.50	2.10
240RA/250RA/540RA 8	3.52	2.81	2.11	1.76	1.41
240RA/250RA/540RA 9T5	4.57	3.87	3.17	2.46	1.76
240RA/250RA/540RA 9	5.63	4.57	3.52	2.81	2.11
240RA/250RA/540RA 12	7.03	5.63	4.22	3.52	2.46
240RA/250RA/540RA 16	13.72	11.25	8.79	6.68	5.28
240RA/250RA/540RA 20	19.34	15.83	12.31	9.50	7.39
<b>R-1234YF</b>					
100RB	0.32	0.25	0.20	0.15	0.11
150RB 1	0.32	0.25	0.20	0.15	0.11
150RB 3	0.81	0.64	0.49	0.36	0.26
150RB 7	1.12	0.88	0.68	0.50	0.36
150RB 9	2.12	1.67	1.28	0.95	0.69
200RB/500RB 2	0.81	0.64	0.49	0.36	0.26
200RB/500RB 3	1.12	0.88	0.68	0.50	0.36
200RB/500RB 4	2.12	1.67	1.28	0.95	0.69
200RB/500RB 5	2.58	2.02	1.55	1.16	0.84
200RB/500RB 6	2.72	2.14	1.64	1.22	0.89
<b>R-134A</b>					
100RB	0.37	0.30	0.23	0.15	0.11
150RB 1	0.37	0.30	0.23	0.15	0.11
150RB 3	0.91	0.74	0.56	0.39	0.28
150RB 7	1.27	1.02	0.74	0.53	0.35
150RB 9	2.43	1.90	1.48	0.98	0.56
200RB/500RB 2	0.91	0.74	0.56	0.39	0.28
200RB/500RB 3	1.27	1.02	0.74	0.53	0.35
200RB/500RB 4	2.43	1.90	1.48	0.98	0.56
200RB/500RB 5	2.92	2.29	1.65	1.20	0.81
200RB/500RB 6	3.09	2.43	1.83	1.30	0.91
200RB/500RB 7	5.30	4.20	3.10	2.50	1.80
240RA/250RA/540RA 8	2.81	2.11	1.76	1.41	1.06
240RA/250RA/540RA 9T5	4.92	3.87	2.81	2.11	1.41
240RA/250RA/540RA 9	5.98	4.92	3.87	2.81	1.76
240RA/250RA/540RA 12	6.68	5.28	4.22	3.17	2.11
240RA/250RA/540RA 16	11.25	8.79	6.68	4.92	3.52
240RA/250RA/540RA 20	15.47	12.31	9.50	7.03	5.63

Note: Capacity is based on largest connection size.

Suction gas capacities - tons

Suction gas capacities @ 2 psi pressure drop					
Valve series	Evaporator temperature - f				
	40	20	0	-20	-40
<b>R-22/R407C</b>					
100RB	0.14	0.11	0.09	0.07	0.05
150RB 1	0.14	0.11	0.09	0.07	0.05
150RB 3	0.34	0.28	0.22	0.18	0.13
150RB 7	0.47	0.38	0.31	0.24	0.18
150RB 9	0.89	0.73	0.58	0.46	0.34
200RB/500RB 2	0.34	0.28	0.22	0.18	0.13
200RB/500RB 3	0.47	0.38	0.31	0.24	0.18
200RB/500RB 4	0.89	0.73	0.58	0.46	0.34
200RB/500RB 5	1.08	0.88	0.71	0.55	0.39
200RB/500RB 6	1.14	0.93	0.75	0.59	0.43
200RB/500RB 7	1.90	1.00	1.30	1.00	0.76
240RA/250RA/540RA 8	1.50	1.20	1.00	0.80	0.60
240RA/250RA/540RA 9T5	2.00	1.60	1.30	1.00	0.80
240RA/250RA/540RA 9	2.40	2.00	1.60	1.20	1.00
240RA/250RA/540RA 12	2.90	2.40	1.90	1.50	1.20
240RA/250RA/540RA 16	5.80	4.70	3.80	3.00	2.30
240RA/250RA/540RA 20	8.20	6.70	5.40	4.20	3.30
<b>R-290</b>					
100RB	0.24	0.33	0.26	0.02	0.15
150RB 1	0.24	0.33	0.26	0.02	0.15
150RB 3	0.59	0.83	0.65	0.05	0.38
150RB 7	0.82	1.15	0.90	0.70	0.52
150RB 9	1.55	2.17	1.71	1.32	0.99
200RB/500RB 2	0.59	0.83	0.65	0.05	0.38
200RB/500RB 3	0.82	1.15	0.90	0.70	0.52
200RB/500RB 4	1.55	2.17	1.71	1.32	0.99
200RB/500RB 5	1.88	2.64	2.08	1.60	1.20
200RB/500RB 6	1.99	2.78	2.19	1.69	1.27
200RB/500RB 7	3.31	4.64	3.65	2.82	2.12
<b>R-32</b>					
100RB	0.21	0.17	0.14	0.11	0.08
150RB 1	0.21	0.17	0.14	0.11	0.08
150RB 3	0.53	0.44	0.34	0.28	0.20
150RB 7	0.73	0.59	0.48	0.37	0.28
150RB 9	1.39	1.14	0.90	0.72	0.53
200RB/500RB 2	0.53	0.44	0.34	0.28	0.20
200RB/500RB 3	0.73	0.59	0.48	0.37	0.28
200RB/500RB 4	1.39	1.14	0.90	0.72	0.53
200RB/500RB 5	1.68	1.37	1.11	0.86	0.61
200RB/500RB 6	1.78	1.45	1.17	0.92	0.67
250RA 8	2.34	1.87	1.56	1.25	0.94
250RA 9T (5/8)	3.12	2.50	2.03	1.56	1.25
250RA 9T (7/8 & Up)	3.74	3.12	2.50	1.87	1.56
250RA 12	4.52	3.74	2.96	2.34	1.87
250RA 16	9.05	7.33	5.93	4.68	3.59
250RA 20	12.79	10.45	8.42	6.55	5.15

Suction gas capacities - kw

Suction gas capacities @ 14.0 Kpa pressure drop					
Valve series	Evaporator temperature - c				
	4	-7	-18	-29	-40
<b>R-22/R407C</b>					
100RB	0.48	0.39	0.31	0.25	0.18
150RB 1	0.48	0.39	0.31	0.25	0.18
150RB 3	1.20	0.98	0.77	0.63	0.46
150RB 7	1.65	1.34	1.09	0.84	0.63
150RB 9	3.13	2.57	2.04	1.62	1.20
200RB/500RB 2	1.20	0.98	0.77	0.63	0.46
200RB/500RB 3	1.65	1.34	1.09	0.84	0.63
200RB/500RB 4	3.13	2.57	2.04	1.62	1.20
200RB/500RB 5	3.80	3.09	2.50	1.93	1.37
200RB/500RB 6	4.01	3.27	2.64	2.07	1.51
200RB/500RB 7	6.80	5.60	4.60	3.50	2.70
240RA/250RA/540RA 8	5.28	4.22	3.52	2.81	2.11
240RA/250RA/540RA 9T5	7.03	5.63	4.57	3.52	2.81
240RA/250RA/540RA 9	8.44	7.03	5.63	4.22	3.52
240RA/250RA/540RA 12	10.20	8.44	6.68	5.28	4.22
240RA/250RA/540RA 16	20.40	16.53	13.36	10.55	8.09
240RA/250RA/540RA 20	28.84	23.56	18.99	14.77	11.61
<b>R-290</b>					
100RB	0.83	1.17	0.91	0.07	0.53
150RB 1	0.83	1.17	0.91	0.07	0.53
150RB 3	2.08	2.92	2.29	1.76	1.34
150RB 7	2.88	4.04	3.17	2.46	1.83
150RB 9	5.45	7.63	6.01	4.64	3.48
200RB/500RB 2	2.08	2.92	2.29	1.76	1.34
200RB/500RB 3	2.88	4.04	3.17	2.46	1.83
200RB/500RB 4	5.45	7.63	6.01	4.64	3.48
200RB/500RB 5	6.61	9.28	7.32	5.63	4.22
200RB/500RB 6	7.00	9.78	7.70	5.94	4.47
200RB/500RB 7	11.64	16.32	12.84	9.92	7.46
<b>R-32</b>					
100RB	0.75	0.61	0.48	0.40	0.29
150RB 1	0.75	0.61	0.48	0.40	0.29
150RB 3	1.87	1.54	1.21	0.99	0.71
150RB 7	2.58	2.08	1.70	1.32	0.99
150RB 9	4.88	4.01	3.18	2.52	1.87
200RB/500RB 2	1.87	1.54	1.21	0.99	0.71
200RB/500RB 3	2.58	2.08	1.70	1.32	0.99
200RB/500RB 4	4.88	4.01	3.18	2.52	1.87
200RB/500RB 5	5.93	4.83	3.90	3.02	2.14
200RB/500RB 6	6.25	5.10	4.11	3.24	2.36
250RA 8	8.23	6.58	5.49	4.39	3.29
250RA 9T (5/8)	10.97	8.78	7.13	5.49	4.39
250RA 9T (7/8 & Up)	13.17	10.97	8.78	6.58	5.49
250RA 12	15.91	13.17	10.42	8.23	6.58
250RA 16	31.82	25.79	20.85	16.46	12.62
250RA 20	44.99	36.76	29.63	23.04	18.11

Note: Capacity is based on largest connection size.

*Suction gas capacities - tons*

*Suction gas capacities - kw*

Suction gas capacities @ 2 psi pressure drop					
Valve series	Evaporator temperature - f				
	40	20	0	-20	-40
<b>R-404A/R-507</b>					
100RB	0.12	0.09	0.07	0.06	0.04
150RB 1	0.12	0.09	0.07	0.06	0.04
150RB 3	0.29	0.23	0.18	0.14	0.10
150RB 7	0.39	0.31	0.24	0.19	0.13
150RB 9	0.74	0.54	0.46	0.35	0.26
200RB/500RB 2	0.29	0.23	0.18	0.14	0.10
200RB/500RB 3	0.39	0.31	0.24	0.19	0.13
200RB/500RB 4	0.74	0.54	0.46	0.35	0.26
200RB/500RB 5	0.90	0.71	0.56	0.42	0.30
200RB/500RB 6	0.95	0.76	0.59	0.45	0.32
200RB/500RB 7	1.70	1.30	1.00	0.80	0.60
240RA/250RA/540RA 8	0.90	0.70	0.50	0.40	0.30
240RA/250RA/540RA 9T5	1.50	1.20	0.90	0.70	0.50
240RA/250RA/540RA 9	1.90	1.50	1.20	0.90	0.60
240RA/250RA/540RA 12	2.20	1.80	1.40	1.00	0.80
240RA/250RA/540RA 16	3.40	2.70	2.10	1.60	1.20
240RA/250RA/540RA 20	4.80	3.80	2.90	2.20	1.60
<b>R-410A</b>					
100RB	0.16	0.14	0.11	0.09	0.06
150RB 1	0.16	0.14	0.11	0.09	0.06
150RB 3	0.28	0.22	0.20	0.21	0.16
150RB 7	0.57	0.46	0.37	0.29	0.23
150RB 9	1.07	0.88	0.70	0.55	0.43
200RB/500RB 2	0.41	0.34	0.27	0.22	0.16
200RB/500RB 3	0.57	0.46	0.37	0.29	0.23
200RB/500RB 4	1.07	0.88	0.70	0.55	0.43
200RB/500RB 5	1.30	1.06	0.85	0.67	0.51
200RB/500RB 6	1.37	1.12	0.90	0.72	0.55
200RB/500RB 7	2.40	2.00	1.60	1.20	1.00
250RA 8	1.82	1.45	1.21	0.97	0.73
250RA 9T5	2.42	1.94	1.57	1.21	0.97
250RA 9	2.90	2.42	1.94	1.45	1.21
250RA 12	3.51	2.90	2.30	1.82	1.45
250RA 16	7.02	5.69	4.60	3.63	2.78
250RA 20	9.92	8.11	6.53	5.08	3.99
<b>R-448A/R-449A</b>					
100RB	0.13	0.12	0.10	0.08	0.06
150RB 1	0.13	0.12	0.10	0.08	0.06
150RB 3	0.32	0.30	0.25	0.19	0.15
150RB 7	0.44	0.42	0.34	0.27	0.21
150RB 9	0.82	0.80	0.65	0.51	0.40
200RB/500RB 2	0.32	0.30	0.25	0.19	0.15
200RB/500RB 3	0.44	0.42	0.34	0.27	0.21
200RB/500RB 4	0.82	0.80	0.65	0.51	0.40
200RB/500RB 5	1.00	0.97	0.79	0.61	0.48
200RB/500RB 6	1.06	1.02	0.83	0.65	0.51
200RB/500RB 7	1.76	1.70	1.38	1.08	0.85
240RA/250RA/540RA 8	1.39	1.34	1.09	0.85	0.67
240RA/250RA/540RA 9T5	1.85	1.79	1.46	1.14	0.89
240RA/250RA/540RA 9	2.22	2.15	1.75	1.36	1.07
240RA/250RA/540RA 12	2.69	2.59	2.11	1.65	1.30
240RA/250RA/540RA 16	5.37	5.19	4.22	3.30	2.59
240RA/250RA/540RA 20	7.60	7.33	5.97	4.66	3.66
<b>R-454A</b>					
100RB	0.13	0.10	0.07	0.06	0.05
150RB 1	0.13	0.10	0.07	0.06	0.05
150RB 3	0.33	0.26	0.18	0.16	0.12
150RB 7	0.45	0.36	0.25	0.22	0.16
150RB 9	0.85	0.67	0.47	0.42	0.31
200RB/500RB 2	0.33	0.26	0.18	0.16	0.12
200RB/500RB 3	0.45	0.36	0.25	0.22	0.16
200RB/500RB 4	0.85	0.67	0.47	0.42	0.31
200RB/500RB 5	1.03	0.82	0.57	0.50	0.38
200RB/500RB 6	1.09	0.86	0.60	0.53	0.40
250RA/540RA 8	1.43	1.14	0.79	0.70	0.53
250RA/540RA 9T5	1.91	1.52	1.05	0.93	0.70
250RA/540RA 9	2.29	1.82	1.26	1.12	0.84
250RA/540RA 12	2.77	2.20	1.52	1.35	1.02
250RA/540RA 16	5.54	4.40	3.04	2.71	2.03
250RA/540RA 20	7.84	6.22	4.30	3.83	2.88

Suction gas capacities @ 14.0 Kpa pressure drop					
Valve series	Evaporator temperature - c				
	4	-7	-18	-29	-40
<b>R-404A/R-507</b>					
100RB	0.41	0.32	0.25	0.20	0.14
150RB 1	0.41	0.32	0.25	0.20	0.14
150RB 3	1.02	0.81	0.63	0.49	0.35
150RB 7	1.37	1.09	0.84	0.67	0.46
150RB 9	2.60	1.90	1.62	1.23	0.91
200RB/500RB 2	1.02	0.81	0.63	0.49	0.35
200RB/500RB 3	1.37	1.09	0.84	0.67	0.46
200RB/500RB 4	2.60	1.90	1.62	1.23	0.91
200RB/500RB 5	3.17	2.50	1.97	1.48	1.06
200RB/500RB 6	3.34	2.67	2.07	1.58	1.13
200RB/500RB 7	6.00	4.60	3.50	2.80	2.10
240RA/250RA/540RA 8	3.17	2.46	1.76	1.41	1.06
240RA/250RA/540RA 9T5	5.28	4.22	3.17	2.46	1.76
240RA/250RA/540RA 9	6.68	5.28	4.22	3.17	2.11
240RA/250RA/540RA 12	7.74	6.33	4.92	3.52	2.81
240RA/250RA/540RA 16	11.96	9.50	7.39	5.63	4.22
240RA/250RA/540RA 20	16.88	13.36	10.20	7.74	5.63
<b>R-410A</b>					
100RB	0.58	0.48	0.37	0.31	0.22
150RB 1	0.58	0.48	0.37	0.31	0.22
150RB 3	0.98	0.77	0.70	0.74	0.56
150RB 7	2.00	1.62	1.30	1.02	0.81
150RB 9	3.76	3.09	2.46	1.93	1.51
200RB/500RB 2	1.45	1.19	0.94	0.77	0.55
200RB/500RB 3	2.00	1.62	1.30	1.02	0.81
200RB/500RB 4	3.76	3.09	2.46	1.93	1.51
200RB/500RB 5	4.57	3.73	2.99	2.36	1.79
200RB/500RB 6	4.82	3.94	3.17	2.53	1.93
200RB/500RB 7	8.40	7.00	5.60	4.20	3.50
250RA 8	6.38	5.11	4.26	3.40	2.55
250RA 9T5	8.51	6.81	5.53	4.26	3.40
250RA 9	10.21	8.51	6.81	5.11	4.26
250RA 12	12.34	10.21	8.09	6.38	5.11
250RA 16	24.68	20.00	16.17	12.77	9.79
250RA 20	34.90	28.51	22.98	17.87	14.04
<b>R-448A/R-449A</b>					
100RB	0.45	0.42	0.35	0.27	0.21
150RB 1	0.45	0.42	0.35	0.27	0.21
150RB 3	1.11	1.07	0.87	0.68	0.53
150RB 7	1.53	1.48	1.20	0.94	0.74
150RB 9	2.90	2.80	2.28	1.78	1.40
200RB/500RB 2	1.11	1.07	0.87	0.68	0.53
200RB/500RB 3	1.53	1.48	1.20	0.94	0.74
200RB/500RB 4	2.90	2.80	2.28	1.78	1.40
200RB/500RB 5	3.52	3.40	2.76	2.16	1.70
200RB/500RB 6	3.72	3.59	2.92	2.28	1.79
200RB/500RB 7	6.19	5.98	4.86	3.80	2.98
240RA/250RA/540RA 8	4.89	4.72	3.84	3.00	2.36
240RA/250RA/540RA 9T5	6.52	6.29	5.12	4.00	3.14
240RA/250RA/540RA 9	7.82	7.55	6.14	4.80	3.77
240RA/250RA/540RA 12	9.45	9.12	7.42	5.80	4.56
240RA/250RA/540RA 16	18.90	18.24	14.84	11.59	9.11
240RA/250RA/540RA 20	26.72	25.79	20.98	16.39	12.88
<b>R-454A</b>					
100RB	0.46	0.36	0.25	0.22	0.17
150RB 1	0.46	0.36	0.25	0.22	0.17
150RB 3	1.14	0.91	0.63	0.56	0.42
150RB 7	1.58	1.25	0.87	0.77	0.58
150RB 9	2.99	2.37	1.64	1.46	1.10
200RB/500RB 2	1.14	0.91	0.63	0.56	0.42
200RB/500RB 3	1.58	1.25	0.87	0.77	0.58
200RB/500RB 4	2.99	2.37	1.64	1.46	1.10
200RB/500RB 5	3.63	2.88	1.99	1.77	1.33
200RB/500RB 6	3.83	3.04	2.10	1.87	1.41
250RA/540RA 8	5.04	4.00	2.76	2.46	1.85
250RA/540RA 9T5	6.72	5.33	3.69	3.28	2.47
250RA/540RA 9	8.07	6.40	4.42	3.94	2.96
250RA/540RA 12	9.75	7.73	5.35	4.76	3.58
250RA/540RA 16	19.50	15.46	10.69	9.52	7.16
250RA/540RA 20	27.57	21.86	15.11	13.46	10.12

**Note:** Capacity is based on largest connection size.

Suction gas capacities - tons

Suction gas capacities @ 2 psi pressure drop					
Valve series	Evaporator temperature (°f)				
	40	20	0	-20	-40
<b>R-454B/R-452B</b>					
100RB	0.16	0.13	0.10	0.08	0.06
150RB 1	0.16	0.13	0.10	0.08	0.06
150RB 3	0.39	0.32	0.25	0.21	0.15
150RB 7	0.54	0.44	0.36	0.28	0.21
150RB 9	1.02	0.84	0.67	0.53	0.39
200RB/500RB 2	0.39	0.32	0.25	0.21	0.15
200RB/500RB 3	0.54	0.44	0.36	0.28	0.21
200RB/500RB 4	1.02	0.84	0.67	0.53	0.39
200RB/500RB 5	1.24	1.01	0.82	0.63	0.45
200RB/500RB 6	1.31	1.07	0.86	0.68	0.49
250RA 8	1.73	1.38	1.15	0.92	0.69
250RA 9T5	2.30	1.84	1.50	1.15	0.92
250RA 9	2.76	2.30	1.84	1.38	1.15
250RA 12	3.34	2.76	2.19	1.73	1.38
250RA 16	6.67	5.41	4.37	3.45	2.65
250RA 20	9.43	7.71	6.21	4.83	3.80
<b>R-454C</b>					
100RB	0.12	0.11	0.10	0.08	0.06
150RB 1	0.12	0.11	0.10	0.08	0.06
150RB 3	0.30	0.28	0.25	0.20	0.16
150RB 7	0.41	0.39	0.34	0.28	0.21
150RB 9	0.78	0.74	0.65	0.52	0.41
200RB/500RB 2	0.30	0.28	0.25	0.20	0.16
200RB/500RB 3	0.41	0.39	0.34	0.28	0.21
200RB/500RB 4	0.78	0.74	0.65	0.52	0.41
200RB/500RB 5	0.95	0.89	0.79	0.63	0.49
200RB/500RB 6	1.00	0.94	0.84	0.67	0.52
<b>R-455A</b>					
100RB	0.12	0.10	0.08	0.06	0.04
150RB 1	0.12	0.10	0.08	0.06	0.04
150RB 3	0.30	0.24	0.19	0.15	0.11
150RB 7	0.42	0.34	0.26	0.20	0.15
150RB 9	0.79	0.64	0.50	0.38	0.29
200RB/500RB 2	0.30	0.24	0.19	0.15	0.11
200RB/500RB 3	0.42	0.34	0.26	0.20	0.15
200RB/500RB 4	0.79	0.64	0.50	0.38	0.29
200RB/500RB 5	0.96	0.77	0.61	0.46	0.35
200RB/500RB 6	1.01	0.82	0.64	0.49	0.37
250RA/540RA 8	1.33	1.07	0.84	0.65	0.48
250RA/540RA 9T5	1.78	1.43	1.12	0.86	0.64
250RA/540RA 9	2.14	1.72	1.35	1.03	0.77
250RA/540RA 12	2.58	2.07	1.63	1.25	0.93
250RA/540RA 16	5.16	4.15	3.26	2.50	1.86
250RA/540RA 20	7.30	5.87	4.61	3.53	2.63

Suction gas capacities - kw

Suction gas capacities @ 14.0 Kpa pressure drop					
Valve series	Evaporator temperature (°c)				
	4	-7	-18	-29	-40
<b>R-454B/R-452B</b>					
100RB	0.55	0.45	0.36	0.29	0.21
150RB 1	0.55	0.45	0.36	0.29	0.21
150RB 3	1.38	1.13	0.89	0.73	0.53
150RB 7	1.90	1.54	1.25	0.97	0.73
150RB 9	3.60	2.95	2.35	1.86	1.38
200RB/500RB 2	1.38	1.13	0.89	0.73	0.53
200RB/500RB 3	1.90	1.54	1.25	0.97	0.73
200RB/500RB 4	3.60	2.95	2.35	1.86	1.38
200RB/500RB 5	4.37	3.56	2.87	2.22	1.58
200RB/500RB 6	4.61	3.76	3.03	2.39	1.74
250RA 8	6.07	4.85	4.04	3.24	2.43
250RA 9T5	8.09	6.47	5.26	4.04	3.24
250RA 9	9.71	8.09	6.47	4.85	4.04
250RA 12	11.73	9.71	7.68	6.07	4.85
250RA 16	23.46	19.01	15.37	12.13	9.30
250RA 20	33.16	27.10	21.84	16.99	13.35
<b>R-454C</b>					
100RB	0.42	0.40	0.35	0.28	0.22
150RB 1	0.42	0.40	0.35	0.28	0.22
150RB 3	1.05	0.99	0.88	0.70	0.55
150RB 7	1.45	1.37	1.21	0.97	0.75
150RB 9	2.74	2.59	2.30	1.83	1.43
200RB/500RB 2	1.05	0.99	0.88	0.70	0.55
200RB/500RB 3	1.45	1.37	1.21	0.97	0.75
200RB/500RB 4	2.74	2.59	2.30	1.83	1.43
200RB/500RB 5	3.33	3.14	2.79	2.22	1.73
200RB/500RB 6	3.51	3.31	2.94	2.35	1.83
<b>R-455A</b>					
100RB	0.43	0.34	0.27	0.21	0.15
150RB 1	0.43	0.34	0.27	0.21	0.15
150RB 3	1.06	0.86	0.67	0.51	0.38
150RB 7	1.47	1.18	0.93	0.71	0.53
150RB 9	2.79	2.24	1.76	1.35	1.00
200RB/500RB 2	1.06	0.86	0.67	0.51	0.38
200RB/500RB 3	1.47	1.18	0.93	0.71	0.53
200RB/500RB 4	2.79	2.24	1.76	1.35	1.00
200RB/500RB 5	3.38	2.72	2.13	1.64	1.22
200RB/500RB 6	3.57	2.87	2.25	1.73	1.28
250RA/540RA 8	4.69	3.77	2.96	2.27	1.69
250RA/540RA 9T5	6.26	5.03	3.95	3.03	2.25
250RA/540RA 9	7.51	6.04	4.74	3.63	2.70
250RA/540RA 12	9.08	7.30	5.73	4.39	3.27
250RA/540RA 16	18.15	14.59	11.46	8.78	6.53
250RA/540RA 20	25.66	20.63	16.21	12.42	9.24

Note: Capacity is based on largest connection size.

Suction gas capacities - tons

Suction gas capacities - kw

Suction gas capacities @ 2 psi pressure drop					
Valve series	Evaporator temperature (°f)				
	40	20	0	-20	-40
<b>R-502</b>					
100RB	0.11	0.09	0.07	0.05	0.04
150RB 1	0.11	0.09	0.07	0.05	0.04
150RB 3	0.28	0.22	0.17	0.13	0.10
150RB 7	0.38	0.30	0.24	0.19	0.13
150RB 9	0.71	0.57	0.45	0.35	0.26
200RB/500RB 2	0.28	0.22	0.17	0.13	0.10
200RB/500RB 3	0.38	0.30	0.24	0.19	0.13
200RB/500RB 4	0.71	0.57	0.45	0.35	0.26
200RB/500RB 5	0.86	0.69	0.55	0.42	0.30
200RB/500RB 6	0.92	0.74	0.58	0.45	0.33
200RB/500RB 7	1.60	1.30	1.00	0.80	0.60
240RA/250RA/540RA 8	1.20	1.00	0.80	0.60	0.40
240RA/250RA/540RA 9T5	1.60	1.30	1.00	0.80	0.60
240RA/250RA/540RA 9	1.90	1.50	1.20	0.90	0.07
240RA/250RA/540RA 12	2.30	1.90	14.50	1.10	0.80
240RA/250RA/540RA 16	4.60	3.70	2.90	2.30	1.70
240RA/250RA/540RA 20	6.50	5.20	4.10	3.20	2.40
<b>R-513A/R-450A</b>					
100RB	0.10	0.08	0.06	0.04	0.03
150RB 1	0.10	0.08	0.06	0.04	0.03
150RB 3	0.24	0.19	0.15	0.11	0.08
150RB 7	0.33	0.27	0.20	0.15	0.11
150RB 9	0.62	0.50	0.39	0.29	0.21
200RB/500RB 2	0.24	0.19	0.15	0.11	0.08
200RB/500RB 3	0.33	0.27	0.20	0.15	0.11
200RB/500RB 4	0.62	0.50	0.39	0.29	0.21
200RB/500RB 5	0.76	0.61	0.47	0.35	0.26
200RB/500RB 6	0.80	0.64	0.50	0.37	0.27
200RB/500RB 7	1.33	1.07	0.83	0.62	0.45
240RA/250RA/540RA 8	1.05	0.85	0.65	0.49	0.35
240RA/250RA/540RA 9T5	1.40	1.13	0.87	0.65	0.47
240RA/250RA/540RA 9	1.68	1.35	1.04	0.78	0.57
240RA/250RA/540RA 12	2.03	1.64	1.26	0.94	0.69
240RA/250RA/540RA 16	4.06	3.27	2.52	1.89	1.37
240RA/250RA/540RA 20	5.74	4.63	3.56	2.67	1.94

Suction gas capacities @ 14.0 Kpa pressure drop					
Valve series	Evaporator temperature (°c)				
	4	-7	-18	-29	-40
<b>R-502</b>					
100RB	0.39	0.31	0.24	0.18	0.14
150RB 1	0.39	0.31	0.24	0.18	0.14
150RB 3	0.98	0.77	0.60	0.46	0.35
150RB 7	1.34	1.06	0.84	0.67	0.46
150RB 9	2.50	2.00	1.58	1.23	0.91
200RB/500RB 2	0.98	0.77	0.60	0.46	0.35
200RB/500RB 3	1.34	1.06	0.84	0.67	0.46
200RB/500RB 4	2.50	2.00	1.58	1.23	0.91
200RB/500RB 5	3.02	2.43	1.93	1.48	1.06
200RB/500RB 6	3.24	2.60	2.04	1.58	1.16
200RB/500RB 7	5.60	4.60	3.50	2.80	2.10
240RA/250RA/540RA 8	4.22	3.52	2.81	2.11	1.41
240RA/250RA/540RA 9T5	5.63	4.57	3.52	2.81	2.11
240RA/250RA/540RA 9	6.68	5.28	4.22	3.17	0.25
240RA/250RA/540RA 12	8.09	6.68	51.00	3.87	2.81
240RA/250RA/540RA 16	16.18	13.01	10.20	8.09	5.98
240RA/250RA/540RA 20	22.86	18.29	14.42	11.25	8.44
<b>R-513A/R-450A</b>					
100RB	0.34	0.27	0.21	0.15	0.11
150RB 1	0.34	0.27	0.21	0.15	0.11
150RB 3	0.84	0.67	0.52	0.39	0.28
150RB 7	1.16	0.93	0.72	0.54	0.39
150RB 9	2.19	1.77	1.36	1.02	0.74
200RB/500RB 2	0.84	0.67	0.52	0.39	0.28
200RB/500RB 3	1.16	0.93	0.72	0.54	0.39
200RB/500RB 4	2.19	1.77	1.36	1.02	0.74
200RB/500RB 5	2.66	2.14	1.65	1.24	0.90
200RB/500RB 6	2.80	2.26	1.74	1.31	0.95
200RB/500RB 7	4.67	3.77	2.90	2.18	1.58
240RA/250RA/540RA 8	3.69	2.98	2.29	1.72	1.25
240RA/250RA/540RA 9T5	4.92	3.97	3.06	2.29	1.66
240RA/250RA/540RA 9	5.90	4.76	3.67	2.75	2.00
240RA/250RA/540RA 12	7.13	5.75	4.43	3.32	2.41
240RA/250RA/540RA 16	14.27	11.51	8.87	6.65	4.83
240RA/250RA/540RA 20	20.17	16.27	12.53	9.40	6.82

Suction gas capacities @ 2 psi pressure drop					
Valve series	Evaporator temperature (°f)				
	0	-10	-20	-30	-40
<b>R-744</b>					
100RB	0.21	0.20	0.18	0.17	0.16
150RB 1	0.21	0.20	0.18	0.17	0.16
150RB 3	0.52	0.49	0.46	0.43	0.39
150RB 7	1.07	1.00	0.94	0.87	0.80
150RB 9	2.00	1.88	1.76	1.63	1.50
200RB/500RB 2	0.52	0.49	0.46	0.43	0.39
200RB/500RB 3	1.07	1.00	0.94	0.87	0.80
200RB/500RB 4	2.00	1.88	1.76	1.63	1.50
200RB/500RB 5	2.43	2.29	2.14	1.98	1.82
200RB/500RB 6	2.56	2.41	2.25	2.09	1.92
200RB/500RB 7	2.71	2.55	2.39	2.21	2.03
250RA 8	3.38	3.18	2.97	2.76	2.53
250RA 9T5	4.48	4.22	3.94	3.66	3.36
250RA 9	5.40	5.09	4.75	4.41	4.05
250RA 12	6.50	6.12	5.72	5.31	4.88
250RA 16	13.03	12.27	11.45	10.64	9.77
250RA 20	18.41	17.33	16.18	15.03	13.80

Suction gas capacities @ 14.0 Kpa pressure drop					
Valve series	Evaporator temperature (°f)				
	0	-10	-20	-30	-40
<b>R-744</b>					
100RB	0.73	0.69	0.65	0.60	0.55
150RB 1	0.73	0.69	0.65	0.60	0.55
150RB 3	1.84	1.73	1.62	1.50	1.38
150RB 7	3.75	3.53	3.30	3.06	2.81
150RB 9	7.03	6.63	6.19	5.74	5.27
200RB/500RB 2	1.84	1.73	1.62	1.50	1.38
200RB/500RB 3	3.75	3.53	3.30	3.06	2.81
200RB/500RB 4	7.03	6.63	6.19	5.74	5.27
200RB/500RB 5	8.55	8.05	7.52	6.97	6.41
200RB/500RB 6	9.01	8.49	7.93	7.35	6.75
200RB/500RB 7	9.53	8.98	8.39	7.78	7.14
250RA 8	11.88	11.19	10.45	9.70	8.91
250RA 9T5	15.76	14.83	13.85	12.86	11.82
250RA 9	19.00	17.88	16.70	15.51	14.25
250RA 12	22.87	21.53	20.10	18.67	17.15
250RA 16	45.83	43.14	40.28	37.41	34.37
250RA 20	64.74	60.94	56.90	52.85	48.55

Note: Shading indicates nominal ratings at 20°F Liquid, -20°F Evaporating Temperature, and 25°F Superheat

Discharge gas capacities - tons

Pressure drop across valve - psi						
Valve series	2.0	5.0	10	25.0	50	100
<b>R-12</b>						
100RB	0.10	0.20	0.30	0.50	0.50	0.50
150RB 1	0.10	0.20	0.30	0.50	0.50	0.50
150RB 3	0.35	0.50	0.75	1.05	1.20	1.35
150RB 7	0.45	0.75	1.00	1.45	1.75	1.85
150RB 9	0.85	1.35	1.95	2.70	3.55	4.25
200RB/500RB 2	0.35	0.50	0.75	1.05	1.20	1.35
200RB/500RB 3	0.45	0.75	1.00	1.45	1.75	1.85
200RB/500RB 4	0.85	1.35	1.95	2.70	3.55	4.25
200RB/500RB 5	1.05	1.65	2.45	3.30	4.45	5.45
200RB/500RB 6	1.15	1.75	2.50	3.70	4.80	5.85
200RB/500RB 7	1.50	2.40	3.30	5.20	6.60	7.20
240RA/250RA/540RA 8	1.50	2.40	3.30	5.20	6.60	7.20
240RA/250RA/540RA 9T5	2.50	4.00	5.60	8.30	10.40	11.20
240RA/250RA/540RA 9	3.20	5.00	7.10	10.10	12.10	11.10
240RA/250RA/540RA 12	3.50	5.50	7.80	11.70	14.00	12.40
240RA/250RA/540RA 16	5.80	9.10	12.90	18.90	23.60	24.30
240RA/250RA/540RA 20	8.10	12.80	18.10	28.20	34.40	33.10
<b>R-1234YF</b>						
100RB	0.13	0.20	0.28	0.41	0.52	0.54
150RB 1	0.13	0.20	0.28	0.41	0.52	0.54
150RB 3	0.29	0.45	0.63	0.93	1.17	1.23
150RB 7	0.42	0.65	0.91	1.34	1.68	1.77
150RB 9	0.81	1.26	1.74	2.58	3.24	3.40
200RB/500RB 2	0.29	0.45	0.63	0.93	1.17	1.23
200RB/500RB 3	0.42	0.65	0.91	1.34	1.68	1.77
200RB/500RB 4	0.81	1.26	1.74	2.58	3.24	3.40
200RB/500RB 5	0.97	1.51	2.09	3.10	3.88	4.09
200RB/500RB 6	1.03	1.61	2.23	3.30	4.14	4.36
<b>R-134A</b>						
100RB	0.20	0.20	0.30	0.50	0.60	0.60
150RB 1	0.20	0.20	0.30	0.50	0.60	0.60
150RB 3	0.40	0.65	0.90	1.30	1.55	1.40
150RB 7	0.55	0.85	1.20	1.75	2.15	2.05
150RB 9	1.00	1.65	2.30	3.25	4.30	5.20
200RB/500RB 2	0.40	0.65	0.90	1.30	1.55	1.40
200RB/500RB 3	0.55	0.85	1.20	1.75	2.15	2.05
200RB/500RB 4	1.00	1.65	2.30	3.25	4.30	5.20
200RB/500RB 5	1.25	2.00	2.85	4.00	5.40	6.85
200RB/500RB 6	1.35	2.15	3.00	4.45	5.80	6.95
200RB/500RB 7	1.80	2.80	4.00	6.20	8.00	8.90
240RA/250RA/540RA 8	1.80	2.80	4.00	6.20	8.00	8.90
240RA/250RA/540RA 9T5	3.00	4.70	6.70	10.00	12.70	13.90
240RA/250RA/540RA 9	3.80	6.00	8.50	12.20	14.80	14.20
240RA/250RA/540RA 12	4.20	6.60	9.40	14.20	17.10	15.90
240RA/250RA/540RA 16	6.90	10.90	15.40	22.80	28.60	30.40
240RA/250RA/540RA 20	9.70	15.30	21.60	34.00	41.90	41.90

Discharge gas capacities - kw

Pressure drop across valve - kpa						
Valve series	13.8	34.5	69	172.5	345	690
<b>R-12</b>						
100RB	0.35	0.70	1.06	1.76	1.76	1.76
150RB 1	0.35	0.70	1.06	1.76	1.76	1.76
150RB 3	1.23	1.76	2.64	3.69	4.22	4.75
150RB 7	1.58	2.64	3.52	5.10	6.15	6.51
150RB 9	2.99	4.75	6.86	9.50	12.48	14.95
200RB/500RB 2	1.23	1.76	2.64	3.69	4.22	4.75
200RB/500RB 3	1.58	2.64	3.52	5.10	6.15	6.51
200RB/500RB 4	2.99	4.75	6.86	9.50	12.48	14.95
200RB/500RB 5	3.69	5.80	8.62	11.61	15.65	19.17
200RB/500RB 6	4.04	6.15	8.79	13.01	16.88	20.57
200RB/500RB 7	5.28	8.44	11.61	18.29	23.21	25.32
240RA/250RA/540RA 8	5.28	8.44	11.61	18.29	23.21	25.32
240RA/250RA/540RA 9T5	8.79	14.07	19.69	29.19	36.58	39.39
240RA/250RA/540RA 9	11.25	17.58	24.97	35.52	42.55	39.04
240RA/250RA/540RA 12	12.31	19.34	27.43	41.15	49.24	43.61
240RA/250RA/540RA 16	20.40	32.00	45.37	66.47	83.00	85.46
240RA/250RA/540RA 20	28.49	45.02	63.66	99.18	120.98	116.41
<b>R-1234YF</b>						
100RB	0.45	0.71	0.98	1.45	1.82	1.92
150RB 1	0.45	0.71	0.98	1.45	1.82	1.92
150RB 3	1.02	1.59	2.21	3.27	4.10	4.31
150RB 7	1.48	2.30	3.19	4.72	5.92	6.23
150RB 9	2.84	4.43	6.13	9.08	11.38	11.97
200RB/500RB 2	1.02	1.59	2.21	3.27	4.10	4.31
200RB/500RB 3	1.48	2.30	3.19	4.72	5.92	6.23
200RB/500RB 4	2.84	4.43	6.13	9.08	11.38	11.97
200RB/500RB 5	3.40	5.32	7.36	10.90	13.66	14.37
200RB/500RB 6	3.63	5.67	7.85	11.62	14.57	15.33
<b>R-134A</b>						
100RB	0.70	0.70	1.06	1.76	2.11	2.11
150RB 1	0.70	0.70	1.06	1.76	2.11	2.11
150RB 3	1.41	2.29	3.17	4.57	5.45	4.92
150RB 7	1.93	2.99	4.22	6.15	7.56	7.21
150RB 9	3.52	5.80	8.09	11.43	15.12	18.29
200RB/500RB 2	1.41	2.29	3.17	4.57	5.45	4.92
200RB/500RB 3	1.93	2.99	4.22	6.15	7.56	7.21
200RB/500RB 4	3.52	5.80	8.09	11.43	15.12	18.29
200RB/500RB 5	4.40	7.03	10.02	14.07	18.99	24.09
200RB/500RB 6	4.75	7.56	10.55	15.65	20.40	24.44
200RB/500RB 7	6.33	9.85	14.07	21.80	28.14	31.30
240RA/250RA/540RA 8	6.33	9.85	14.07	21.80	28.14	31.30
240RA/250RA/540RA 9T5	10.55	16.53	23.56	35.17	44.66	48.88
240RA/250RA/540RA 9	13.36	21.10	29.89	42.91	52.05	49.94
240RA/250RA/540RA 12	14.77	23.21	33.06	49.94	60.14	55.92
240RA/250RA/540RA 16	24.27	38.33	54.16	80.19	100.58	106.91
240RA/250RA/540RA 20	34.11	53.81	75.97	119.57	147.36	147.36

Note: Shading indicates AHRI standard ratings  
 Note: Capacity is based on largest connection size.

Discharge gas capacities - tons

Valve series	Pressure drop across valve - psi					
	2.0	5.0	10	25.0	50	100
<b>R-22</b>						
100RB	0.20	0.30	0.40	0.60	0.80	1.00
150RB 1	0.20	0.30	0.40	0.60	0.80	1.00
150RB 3	0.45	0.75	1.05	1.65	2.10	2.40
150RB 7	0.65	1.05	1.45	2.25	2.95	3.35
150RB 9	1.25	1.95	2.80	4.05	5.50	7.05
200RB/500RB 2	0.45	0.75	1.05	1.65	2.10	2.40
200RB/500RB 3	0.65	1.05	1.45	2.25	2.95	3.35
200RB/500RB 4	1.25	1.95	2.80	4.05	5.50	7.05
200RB/500RB 5	1.50	2.37	3.50	4.90	6.75	9.00
200RB/500RB 6	1.60	2.55	3.60	5.50	7.40	9.45
200RB/500RB 7	2.10	3.40	4.80	7.80	10.40	12.80
240RA/250RA/540RA 8	2.10	3.40	4.80	7.80	10.40	12.80
240RA/250RA/540RA 9T5	3.60	5.70	8.10	12.50	16.60	20.40
240RA/250RA/540RA 9	4.60	7.20	10.20	15.40	20.00	23.10
240RA/250RA/540RA 12	5.10	8.00	11.30	18.10	23.40	26.60
240RA/250RA/540RA 16	8.30	13.20	18.70	28.60	37.80	45.63
240RA/250RA/540RA 20	11.70	18.40	26.10	43.00	56.10	66.00
<b>R-290</b>						
100RB	0.35	0.55	0.76	1.16	1.53	1.85
150RB 1	0.35	0.55	0.76	1.16	1.53	1.85
150RB 3	0.78	1.23	1.72	2.61	3.44	4.16
150RB 7	1.13	1.78	2.48	3.77	4.97	6.01
150RB 9	2.18	3.42	4.77	7.25	9.56	11.55
200RB/500RB 2	0.78	1.23	1.72	2.61	3.44	4.16
200RB/500RB 3	1.13	1.78	2.48	3.77	4.97	6.01
200RB/500RB 4	2.18	3.42	4.77	7.25	9.56	11.55
200RB/500RB 5	2.62	4.10	5.73	8.70	11.47	13.86
200RB/500RB 6	2.79	4.38	6.11	9.28	12.24	14.79
200RB/500RB 7	3.66	5.74	8.02	12.18	23.50	30.98
<b>R-32</b>						
100RB	0.31	0.47	0.63	0.94	1.26	1.57
150RB 1	0.31	0.47	0.63	0.94	1.26	1.57
150RB 3	0.71	1.18	1.65	2.59	3.30	3.77
150RB 7	1.02	1.65	2.28	3.53	4.63	5.26
150RB 9	1.96	3.06	4.40	6.36	8.64	11.07
200RB/500RB 2	0.71	1.18	1.65	2.59	3.30	3.77
200RB/500RB 3	1.02	1.65	2.28	3.53	4.63	5.26
200RB/500RB 4	1.96	3.06	4.40	6.36	8.64	11.07
200RB/500RB 5	2.36	3.72	5.50	7.69	10.60	14.13
200RB/500RB 6	2.51	4.00	5.65	8.64	11.62	14.84
250RA 8	3.30	5.34	7.54	12.25	16.33	20.10
250RA 9T (5/8)	5.65	8.95	12.72	19.63	26.06	32.03
250RA 9T (7/8 & Up)	7.22	11.30	16.01	24.18	31.40	36.27
250RA 12	8.01	12.56	17.74	28.42	36.74	41.76
250RA 16	13.03	20.72	29.36	44.90	59.35	71.64
250RA 20	18.37	28.89	40.98	67.51	88.08	103.62

Discharge gas capacities - kw

Valve series	Pressure drop across valve - kpa					
	13.8	34.5	69	172.5	345	690
<b>R-22</b>						
100RB	0.70	1.06	1.41	2.11	2.81	3.52
150RB 1	0.70	1.06	1.41	2.11	2.81	3.52
150RB 3	1.58	2.64	3.69	5.80	7.39	8.44
150RB 7	2.29	3.69	5.10	7.91	10.37	11.78
150RB 9	4.40	6.86	9.85	14.24	19.34	24.79
200RB/500RB 2	1.58	2.64	3.69	5.80	7.39	8.44
200RB/500RB 3	2.29	3.69	5.10	7.91	10.37	11.78
200RB/500RB 4	4.40	6.86	9.85	14.24	19.34	24.79
200RB/500RB 5	5.28	8.34	12.31	17.23	23.74	31.65
200RB/500RB 6	5.63	8.97	12.66	19.34	26.03	33.23
200RB/500RB 7	7.39	11.96	16.88	27.43	36.58	45.02
240RA/250RA/540RA 8	7.39	11.96	16.88	27.43	36.58	45.02
240RA/250RA/540RA 9T5	12.66	20.05	28.49	43.96	58.38	71.74
240RA/250RA/540RA 9	16.18	25.32	35.87	54.16	70.34	81.24
240RA/250RA/540RA 12	17.94	28.14	39.74	63.66	82.30	93.55
240RA/250RA/540RA 16	29.19	46.42	65.77	100.58	132.94	160.48
240RA/250RA/540RA 20	41.15	64.71	91.79	151.23	197.30	232.12
<b>R-290</b>						
100RB	1.23	1.93	2.67	4.08	5.38	6.51
150RB 1	1.23	1.93	2.67	4.08	5.38	6.51
150RB 3	2.74	4.33	6.05	9.18	12.10	14.63
150RB 7	3.97	6.26	8.72	13.26	17.48	21.14
150RB 9	7.67	12.03	16.78	25.50	33.62	40.62
200RB/500RB 2	2.74	4.33	6.05	9.18	12.10	14.63
200RB/500RB 3	3.97	6.26	8.72	13.26	17.48	21.14
200RB/500RB 4	7.67	12.03	16.78	25.50	33.62	40.62
200RB/500RB 5	9.21	14.42	20.15	30.60	40.34	48.74
200RB/500RB 6	9.81	15.40	21.49	32.64	43.05	52.01
200RB/500RB 7	12.87	20.19	28.21	42.84	56.48	68.26
<b>R-32</b>						
100RB	1.10	1.66	2.21	3.31	4.42	5.52
150RB 1	1.10	1.66	2.21	3.31	4.42	5.52
150RB 3	2.48	4.14	5.80	9.11	11.60	13.25
150RB 7	3.59	5.80	8.01	12.42	16.29	18.50
150RB 9	6.90	10.77	15.46	22.36	30.37	38.93
200RB/500RB 2	2.48	4.14	5.80	9.11	11.60	13.25
200RB/500RB 3	3.59	5.80	8.01	12.42	16.29	18.50
200RB/500RB 4	6.90	10.77	15.46	22.36	30.37	38.93
200RB/500RB 5	8.28	13.09	19.33	27.06	37.27	49.69
200RB/500RB 6	8.83	14.08	19.88	30.37	40.86	52.18
250RA 8	11.60	18.77	26.50	43.07	57.42	70.67
250RA 9T (5/8)	19.88	31.47	44.72	69.02	91.66	112.64
250RA 9T (7/8 & Up)	25.40	39.75	56.32	85.03	110.43	127.55
250RA 12	28.16	44.17	62.39	99.94	129.20	146.87
250RA 16	45.83	72.88	103.25	157.91	208.71	251.94
250RA 20	64.60	101.59	144.11	237.42	309.75	364.42

Note: Shading indicates AHRI standard ratings  
 Note: Capacity is based on largest connection size.

Discharge gas capacities - tons

Valve series	Pressure drop across valve - psi					
	2.0	5.0	10	25.0	50	100
	R-404A/R-507					
100RB	0.20	0.30	0.40	0.60	0.70	0.90
150RB 1	0.20	0.30	0.40	0.60	0.70	0.90
150RB 3	0.45	0.70	1.00	1.50	1.95	2.25
150RB 7	0.60	0.95	1.30	2.00	2.65	3.15
150RB 9	1.10	1.75	2.50	3.65	4.95	6.45
200RB/500RB 2	0.45	0.70	1.00	1.50	1.95	2.25
200RB/500RB 3	0.60	0.95	1.30	2.00	2.65	3.15
200RB/500RB 4	1.10	1.75	2.50	3.65	4.95	6.45
200RB/500RB 5	1.35	2.05	3.00	4.35	5.80	8.15
200RB/500RB 6	1.45	2.20	3.15	4.45	6.00	8.67
200RB/500RB 7	1.80	2.90	4.10	5.70	8.90	11.30
240RA/250RA/540RA 8	1.80	2.90	4.10	6.70	8.90	11.30
240RA/250RA/540RA 9T5	3.10	4.90	6.90	10.70	14.30	17.90
240RA/250RA/540RA 9	3.90	6.20	8.70	13.30	17.40	20.20
240RA/250RA/540RA 12	4.30	6.80	9.60	15.50	20.30	23.90
240RA/250RA/540RA 16	7.10	11.30	16.00	23.60	30.80	36.20
240RA/250RA/540RA 20	9.90	15.70	22.20	36.90	48.70	58.90
	R-407C					
100RB	0.20	0.30	0.40	0.60	0.80	1.00
150RB 1	0.20	0.30	0.40	0.60	0.80	1.00
150RB 3	0.45	0.70	0.95	1.45	1.90	2.25
150RB 7	0.60	0.90	1.25	1.95	2.55	3.05
150RB 9	1.05	1.70	2.40	3.50	4.75	6.20
200RB/500RB 2	0.45	0.70	0.95	1.45	1.90	2.25
200RB/500RB 3	0.60	0.90	1.25	1.95	2.55	3.05
200RB/500RB 4	1.05	1.70	2.40	3.50	4.75	6.20
200RB/500RB 5	1.30	2.10	3.00	4.20	5.80	7.85
200RB/500RB 6	1.40	2.20	3.10	4.75	7.55	8.35
200RB/500RB 7	2.10	3.30	4.70	7.70	10.30	13.00
240RA/250RA/540RA 8	2.10	3.30	4.70	7.70	10.30	13.00
240RA/250RA/540RA 9T5	3.60	5.60	8.00	12.40	16.50	20.60
240RA/250RA/540RA 9	4.50	7.10	10.10	15.30	20.00	22.50
240RA/250RA/540RA 12	6.00	9.50	13.40	21.20	29.60	37.10
240RA/250RA/540RA 16	8.20	13.00	18.40	28.40	37.70	46.20
240RA/250RA/540RA 20	11.50	18.20	25.70	42.70	56.10	67.20

Discharge gas capacities - kw

Valve series	Pressure drop across valve - kpa					
	13.8	34.5	69	172.5	345	690
	R-404A/R-507					
100RB	0.70	1.06	1.41	2.11	2.46	3.17
150RB 1	0.70	1.06	1.41	2.11	2.46	3.17
150RB 3	1.58	2.46	3.52	5.28	6.86	7.91
150RB 7	2.11	3.34	4.57	7.03	9.32	11.08
150RB 9	3.87	6.15	8.79	12.84	17.41	22.68
200RB/500RB 2	1.58	2.46	3.52	5.28	6.86	7.91
200RB/500RB 3	2.11	3.34	4.57	7.03	9.32	11.08
200RB/500RB 4	3.87	6.15	8.79	12.84	17.41	22.68
200RB/500RB 5	4.75	7.21	10.55	15.30	20.40	28.66
200RB/500RB 6	5.10	7.74	11.08	15.65	21.10	30.49
200RB/500RB 7	6.33	10.20	14.42	20.05	31.30	39.74
240RA/250RA/540RA 8	6.33	10.20	14.42	23.56	31.30	39.74
240RA/250RA/540RA 9T5	10.90	17.23	24.27	37.63	50.29	62.95
240RA/250RA/540RA 9	13.72	21.80	30.60	46.77	61.19	71.04
240RA/250RA/540RA 12	15.12	23.91	33.76	54.51	71.39	84.05
240RA/250RA/540RA 16	24.97	39.74	56.27	83.00	108.32	127.31
240RA/250RA/540RA 20	34.82	55.22	78.08	129.77	171.27	207.15
	R-407C					
100RB	0.70	1.06	1.41	2.11	2.81	3.52
150RB 1	0.70	1.06	1.41	2.11	2.81	3.52
150RB 3	1.58	2.46	3.34	5.10	6.68	7.91
150RB 7	2.11	3.17	4.40	6.86	8.97	10.73
150RB 9	3.69	5.98	8.44	12.31	16.71	21.80
200RB/500RB 2	1.58	2.46	3.34	5.10	6.68	7.91
200RB/500RB 3	2.11	3.17	4.40	6.86	8.97	10.73
200RB/500RB 4	3.69	5.98	8.44	12.31	16.71	21.80
200RB/500RB 5	4.57	7.39	10.55	14.77	20.40	27.61
200RB/500RB 6	4.92	7.74	10.90	16.71	26.55	29.37
200RB/500RB 7	7.39	11.61	16.53	27.08	36.22	45.72
240RA/250RA/540RA 8	7.39	11.61	16.53	27.08	36.22	45.72
240RA/250RA/540RA 9T5	12.66	19.69	28.14	43.61	58.03	72.45
240RA/250RA/540RA 9	15.83	24.97	35.52	53.81	70.34	79.13
240RA/250RA/540RA 12	21.10	33.41	47.13	74.56	104.10	130.48
240RA/250RA/540RA 16	28.84	45.72	64.71	99.88	132.59	162.48
240RA/250RA/540RA 20	40.44	64.01	90.38	150.17	197.30	236.34

Note: Shading indicates AHRI standard ratings  
 Note: Capacity is based on largest connection size.

Discharge gas capacities - tons

Valve series	Pressure drop across valve - psi					
	2.0	5.0	10	25.0	50	100
	R-410A					
100RB	0.24	0.37	0.49	0.73	0.98	1.22
150RB 1	0.24	0.37	0.49	0.73	0.98	1.22
150RB 3	0.55	0.90	1.30	2.05	2.75	3.40
150RB 7	0.80	1.25	1.75	2.80	3.75	4.70
150RB 9	1.50	2.40	3.35	5.35	6.80	9.10
200RB/500RB 2	0.55	0.90	1.30	2.05	2.75	3.40
200RB/500RB 3	0.80	1.25	1.75	2.80	3.75	4.70
200RB/500RB 4	1.50	2.40	3.35	5.35	6.80	9.10
200RB/500RB 5	1.85	2.95	4.25	6.75	8.30	11.30
200RB/500RB 6	2.00	3.10	4.35	6.85	9.25	12.25
200RB/500RB 7	2.30	3.55	5.00	7.80	9.80	13.00
250RA 8	2.56	4.15	5.86	9.52	12.69	15.62
250RA 9T5	4.39	6.95	9.88	15.25	20.25	24.89
250RA 9	5.61	8.78	12.44	18.79	24.40	28.18
250RA 12	6.22	9.76	13.79	22.08	28.55	32.45
250RA 16	10.13	16.10	22.81	34.89	46.12	55.67
250RA 20	14.27	22.45	31.84	52.46	68.44	80.52

Discharge gas capacities - kw

Valve series	Pressure drop across valve - kpa					
	13.8	34.5	69	172.5	345	690
	R-410A					
100RB	0.86	1.29	1.72	2.57	3.43	4.29
150RB 1	0.86	1.29	1.72	2.57	3.43	4.29
150RB 3	1.93	3.17	4.57	7.21	9.67	11.96
150RB 7	2.81	4.40	6.15	9.85	13.19	16.53
150RB 9	5.28	8.44	11.78	18.82	23.91	32.00
200RB/500RB 2	1.93	3.17	4.57	7.21	9.67	11.96
200RB/500RB 3	2.81	4.40	6.15	9.85	13.19	16.53
200RB/500RB 4	5.28	8.44	11.78	18.82	23.91	32.00
200RB/500RB 5	6.51	10.37	14.95	23.74	29.19	39.74
200RB/500RB 6	7.03	10.90	15.30	24.09	32.53	43.08
200RB/500RB 7	8.09	12.48	17.58	27.43	34.47	45.72
250RA 8	9.01	14.59	20.59	33.47	44.62	54.92
250RA 9T5	15.45	24.46	34.75	53.63	71.22	87.53
250RA 9	19.74	30.89	43.76	66.07	85.81	99.11
250RA 12	21.88	34.32	48.48	77.66	100.40	114.13
250RA 16	35.61	56.64	80.23	122.71	162.18	195.78
250RA 20	50.20	78.95	111.98	184.49	240.70	283.18

Valve series	Pressure drop across valve - psi					
	13.8	34.5	69	172.5	345	690
	R-448A/R-449A					
100RB	0.23	0.36	0.51	0.78	1.04	1.31
150RB 1	0.23	0.36	0.51	0.78	1.04	1.31
150RB 3	0.52	0.81	1.14	1.75	2.34	2.96
150RB 7	0.75	1.17	1.64	2.52	3.39	4.27
150RB 9	1.44	2.26	3.16	4.85	6.51	8.21
200RB/500RB 2	0.52	0.81	1.14	1.75	2.34	2.96
200RB/500RB 3	0.75	1.17	1.64	2.52	3.39	4.27
200RB/500RB 4	1.44	2.26	3.16	4.85	6.51	8.21
200RB/500RB 5	1.72	2.71	3.80	5.82	7.81	9.86
200RB/500RB 6	1.84	2.89	4.05	6.21	8.33	10.51
200RB/500RB 7	2.41	3.79	5.31	8.15	10.94	13.80
240RA/250RA/540RA 8	2.41	3.79	5.31	8.15	10.94	13.80
240RA/250RA/540RA 9T5	4.14	6.51	9.11	13.97	18.75	23.66
240RA/250RA/540RA 9	5.29	8.31	11.64	17.86	23.96	30.23
240RA/250RA/540RA 12	5.86	9.22	12.91	19.80	26.56	33.51
240RA/250RA/540RA 16	9.54	15.00	21.00	32.22	43.23	54.54
240RA/250RA/540RA 20	13.45	21.14	29.61	45.42	60.94	76.89
R-454A						
100RB	0.23	0.36	0.50	0.77	1.03	1.29
150RB 1	0.23	0.36	0.50	0.77	1.03	1.29
150RB 3	0.51	0.80	1.13	1.73	2.31	2.89
150RB 7	0.74	1.16	1.63	2.49	3.33	4.18
150RB 9	1.42	2.24	3.13	4.79	6.41	8.04
200RB/500RB 2	0.51	0.80	1.13	1.73	2.31	2.89
200RB/500RB 3	0.74	1.16	1.63	2.49	3.33	4.18
200RB/500RB 4	1.42	2.24	3.13	4.79	6.41	8.04
200RB/500RB 5	1.71	2.68	3.75	5.75	7.70	9.65
200RB/500RB 6	1.82	2.86	4.00	6.13	8.21	10.29
250RA/540RA 8	2.39	3.76	5.26	8.05	10.77	13.51
250RA/540RA 9T5	4.10	6.44	9.01	13.80	18.47	23.15
250RA/540RA 9	5.23	8.23	11.51	17.63	23.60	29.58
250RA/540RA 12	5.80	9.12	12.76	19.55	26.16	32.80
250RA/540RA 16	9.44	14.84	20.77	31.82	42.58	53.38
250RA/540RA 20	13.31	20.92	29.28	44.85	60.02	75.24

Valve series	Pressure drop across valve - kpa					
	13.8	34.5	69	172.5	345	690
	R-448A/R-449A					
100RB	0.81	1.27	1.78	2.73	3.66	4.62
150RB 1	0.81	1.27	1.78	2.73	3.66	4.62
150RB 3	1.82	2.86	4.00	6.14	8.24	10.40
150RB 7	2.63	4.13	5.78	8.87	11.91	15.02
150RB 9	5.05	7.94	11.12	17.06	22.90	28.89
200RB/500RB 2	1.82	2.86	4.00	6.14	8.24	10.40
200RB/500RB 3	2.63	4.13	5.78	8.87	11.91	15.02
200RB/500RB 4	5.05	7.94	11.12	17.06	22.90	28.89
200RB/500RB 5	6.06	9.53	13.35	20.48	27.48	34.67
200RB/500RB 6	6.47	10.17	14.24	21.84	29.31	36.98
200RB/500RB 7	8.49	13.35	18.69	28.67	38.47	48.53
240RA/250RA/540RA 8	8.49	13.35	18.69	28.67	38.47	48.53
240RA/250RA/540RA 9T5	14.55	22.88	32.04	49.15	65.94	83.20
240RA/250RA/540RA 9	18.60	29.23	40.94	62.80	84.26	106.31
240RA/250RA/540RA 12	20.62	32.41	45.39	69.62	93.42	117.86
240RA/250RA/540RA 16	33.56	52.75	73.86	113.31	152.04	191.82
240RA/250RA/540RA 20	47.30	74.35	104.12	159.72	214.32	270.39
R-454A						
100RB	0.80	1.26	1.76	2.70	3.61	4.52
150RB 1	0.80	1.26	1.76	2.70	3.61	4.52
150RB 3	1.80	2.83	3.96	6.07	8.12	10.18
150RB 7	2.60	4.09	5.72	8.76	11.73	14.70
150RB 9	5.00	7.86	11.00	16.85	22.55	28.27
200RB/500RB 2	1.80	2.83	3.96	6.07	8.12	10.18
200RB/500RB 3	2.60	4.09	5.72	8.76	11.73	14.70
200RB/500RB 4	5.00	7.86	11.00	16.85	22.55	28.27
200RB/500RB 5	6.00	9.43	13.20	20.22	27.06	33.93
200RB/500RB 6	6.40	10.06	14.08	21.57	28.87	36.19
250RA/540RA 8	8.40	13.21	18.48	28.31	37.89	47.50
250RA/540RA 9T5	14.41	22.64	31.69	48.54	64.95	81.43
250RA/540RA 9	18.41	28.93	40.49	62.02	83.00	104.04
250RA/540RA 12	20.41	32.07	44.89	68.76	92.02	115.35
250RA/540RA 16	33.22	52.20	73.06	111.91	149.76	187.73
250RA/540RA 20	46.82	73.58	102.99	157.75	211.10	264.63

Note: Shading indicates AHRI standard ratings  
 Note: Capacity is based on largest connection size.

Discharge gas capacities - tons

Pressure drop across valve - psi						
Valve series	2.0	5.0	10	25.0	50	100
	R-454B/R-452B					
100RB	0.23	0.35	0.46	0.70	0.93	1.16
150RB 1	0.23	0.35	0.46	0.70	0.93	1.16
150RB 3	0.52	0.87	1.22	1.91	2.44	2.78
150RB 7	0.75	1.22	1.68	2.61	3.42	3.89
150RB 9	1.45	2.26	3.25	4.70	6.38	8.18
200RB/500RB 2	0.52	0.87	1.22	1.91	2.44	2.78
200RB/500RB 3	0.75	1.22	1.68	2.61	3.42	3.89
200RB/500RB 4	1.45	2.26	3.25	4.70	6.38	8.18
200RB/500RB 5	1.74	2.75	4.06	5.68	7.83	10.44
200RB/500RB 6	1.86	2.96	4.18	6.38	8.58	10.96
250RA 8	2.44	3.94	5.57	9.05	12.06	14.85
250RA 9T5	4.18	6.61	9.40	14.50	19.26	23.66
250RA 9	5.34	8.35	11.83	17.86	23.20	26.80
250RA 12	5.92	9.28	13.11	21.00	27.14	30.86
250RA 16	9.63	15.31	21.69	33.18	43.85	52.93
250RA 20	13.57	21.34	30.28	49.88	65.08	76.56

Discharge gas capacities - kw

Pressure drop across valve - kpa						
Valve series	13.8	34.5	69	172.5	345	690
	R-454B/R-452B					
100RB	0.82	1.22	1.63	2.45	3.26	4.08
150RB 1	0.82	1.22	1.63	2.45	3.26	4.08
150RB 3	1.84	3.06	4.28	6.73	8.57	9.79
150RB 7	2.65	4.28	5.92	9.18	12.03	13.67
150RB 9	5.10	7.96	11.42	16.52	22.44	28.76
200RB/500RB 2	1.84	3.06	4.28	6.73	8.57	9.79
200RB/500RB 3	2.65	4.28	5.92	9.18	12.03	13.67
200RB/500RB 4	5.10	7.96	11.42	16.52	22.44	28.76
200RB/500RB 5	6.12	9.67	14.28	19.99	27.54	36.72
200RB/500RB 6	6.53	10.40	14.69	22.44	30.19	38.55
250RA 8	8.57	13.87	19.58	31.82	42.43	52.22
250RA 9T5	14.69	23.25	33.04	50.99	67.72	83.22
250RA 9	18.77	29.37	41.61	62.83	81.59	94.24
250RA 12	20.81	32.64	46.10	73.84	95.46	108.52
250RA 16	33.86	53.85	76.29	116.68	154.21	186.15
250RA 20	47.73	75.06	106.48	175.42	228.86	269.25

Pressure drop across valve - psi						
Valve series	2.0	5.0	10	25.0	50	100
	R-454C					
100RB	0.17	0.27	0.38	0.57	0.76	0.91
150RB 1	0.17	0.27	0.38	0.57	0.76	0.91
150RB 3	0.39	0.61	0.85	1.29	1.70	2.05
150RB 7	0.56	0.88	1.23	1.87	2.46	2.96
150RB 9	1.08	1.70	2.37	3.59	4.73	5.69
200RB/500RB 2	0.39	0.61	0.85	1.29	1.70	2.05
200RB/500RB 3	0.56	0.88	1.23	1.87	2.46	2.96
200RB/500RB 4	1.08	1.70	2.37	3.59	4.73	5.69
200RB/500RB 5	1.30	2.04	2.84	4.31	5.68	6.83
200RB/500RB 6	1.38	2.17	3.03	4.60	6.05	7.29
R-455A						
100RB	0.19	0.29	0.41	0.63	0.83	1.01
150RB 1	0.19	0.29	0.41	0.63	0.83	1.01
150RB 3	0.42	0.66	0.93	1.41	1.86	2.28
150RB 7	0.61	0.96	1.34	2.04	2.69	3.29
150RB 9	1.17	1.84	2.57	3.91	5.18	6.32
200RB/500RB 2	0.42	0.66	0.93	1.41	1.86	2.28
200RB/500RB 3	0.61	0.96	1.34	2.04	2.69	3.29
200RB/500RB 4	1.17	1.84	2.57	3.91	5.18	6.32
200RB/500RB 5	1.41	2.21	3.08	4.70	6.22	7.59
200RB/500RB 6	1.50	2.36	3.29	5.01	6.63	8.09
250RA/540RA 8	1.97	3.09	4.32	6.58	8.70	10.62
250RA/540RA 9T5 (5/8)	3.38	5.30	7.40	11.27	14.92	18.21
250RA/540RA 9 (7/8 & Up)	4.31	6.77	9.46	14.40	19.06	23.27
250RA/540RA 12	4.78	7.51	10.49	15.97	21.14	25.80
250RA/540RA 16	7.78	12.22	17.07	25.99	34.40	41.99
250RA/540RA 20	10.97	17.22	24.06	36.63	48.49	59.19

Pressure drop across valve - kpa						
Valve series	13.8	34.5	69	172.5	345	690
	R-454C					
100RB	0.61	0.95	1.33	2.02	2.66	3.20
150RB 1	0.61	0.95	1.33	2.02	2.66	3.20
150RB 3	1.37	2.15	3.00	4.55	5.99	7.21
150RB 7	1.98	3.10	4.33	6.57	8.65	10.41
150RB 9	3.80	5.97	8.33	12.64	16.64	20.02
200RB/500RB 2	1.37	2.15	3.00	4.55	5.99	7.21
200RB/500RB 3	1.98	3.10	4.33	6.57	8.65	10.41
200RB/500RB 4	3.80	5.97	8.33	12.64	16.64	20.02
200RB/500RB 5	4.56	7.16	9.99	15.17	19.96	24.03
200RB/500RB 6	4.87	7.64	10.66	16.18	21.29	25.63
R-455A						
100RB	0.66	1.04	1.45	2.20	2.92	3.56
150RB 1	0.66	1.04	1.45	2.20	2.92	3.56
150RB 3	1.48	2.33	3.25	4.96	6.56	8.01
150RB 7	2.14	3.37	4.70	7.16	9.47	11.56
150RB 9	4.12	6.47	9.04	13.77	18.22	22.24
200RB/500RB 2	1.48	2.33	3.25	4.96	6.56	8.01
200RB/500RB 3	2.14	3.37	4.70	7.16	9.47	11.56
200RB/500RB 4	4.12	6.47	9.04	13.77	18.22	22.24
200RB/500RB 5	4.95	7.77	10.85	16.52	21.86	26.69
200RB/500RB 6	5.28	8.28	11.57	17.62	23.32	28.47
250RA/540RA 8	6.93	10.87	15.19	23.13	30.61	37.36
250RA/540RA 9T5 (5/8)	11.87	18.64	26.04	39.64	52.47	64.05
250RA/540RA 9 (7/8 & Up)	15.17	23.81	33.27	50.66	67.05	81.84
250RA/540RA 12	16.82	26.40	36.88	56.16	74.34	90.74
250RA/540RA 16	27.38	42.97	60.03	91.40	120.98	147.67
250RA/540RA 20	38.59	60.57	84.62	128.84	170.54	208.16

Note: Shading indicates AHRI standard ratings  
 Note: Capacity is based on largest connection size.

Discharge gas capacities - tons

Valve series	Pressure drop across valve - psi					
	2.0	5.0	10	25.0	50	100
	R-502					
100RB	0.20	0.20	0.30	0.50	0.70	0.80
150RB 1	0.20	0.20	0.30	0.50	0.70	0.80
150RB 3	0.40	0.60	0.85	1.35	1.75	2.00
150RB 7	0.55	0.85	1.20	1.80	2.35	2.80
150RB 9	1.00	1.60	2.25	3.25	4.40	5.75
200RB/500RB 2	0.40	0.60	0.85	1.35	1.75	2.00
200RB/500RB 3	0.55	0.85	1.20	1.80	2.35	2.80
200RB/500RB 4	1.00	1.60	2.25	3.25	4.40	5.75
200RB/500RB 5	1.20	1.95	2.75	3.95	5.45	7.30
200RB/500RB 6	1.30	2.05	2.90	4.40	6.00	7.70
200RB/500RB 7	1.70	2.70	3.80	6.20	8.30	10.40
240RA/250RA/540RA 8	1.70	2.70	3.80	6.20	8.30	10.40
240RA/250RA/540RA 9T5	2.90	4.50	6.40	10.00	13.30	16.50
240RA/250RA/540RA 9	3.60	5.70	8.10	12.30	16.10	18.80
240RA/250RA/540RA 12	4.00	6.40	9.00	14.40	18.70	21.70
240RA/250RA/540RA 16	6.60	10.50	14.80	22.80	30.20	37.00
240RA/250RA/540RA 20	9.30	14.60	20.70	34.30	45.00	53.70
R-513A/R-450A						
100RB	0.13	0.20	0.28	0.41	0.51	0.53
150RB 1	0.13	0.20	0.28	0.41	0.51	0.53
150RB 3	0.29	0.46	0.63	0.93	1.16	1.18
150RB 7	0.42	0.66	0.92	1.35	1.67	1.71
150RB 9	0.82	1.27	1.76	2.59	3.22	3.28
200RB/500RB 2	0.29	0.46	0.63	0.93	1.16	1.18
200RB/500RB 3	0.42	0.66	0.92	1.35	1.67	1.71
200RB/500RB 4	0.82	1.27	1.76	2.59	3.22	3.28
200RB/500RB 5	0.98	1.53	2.11	3.11	3.86	3.94
200RB/500RB 6	1.04	1.63	2.25	3.32	4.12	4.20
200RB/500RB 7	1.37	2.14	2.96	4.36	5.41	5.52
240RA/250RA/540RA 8	1.37	2.14	2.96	4.36	5.41	5.52
240RA/250RA/540RA 9T5	2.35	3.67	5.07	7.47	9.27	9.46
240RA/250RA/540RA 9	3.00	4.68	6.48	9.54	11.84	12.09
240RA/250RA/540RA 12	3.33	5.19	7.18	10.58	13.13	13.40
240RA/250RA/540RA 16	5.42	8.45	11.69	17.21	21.37	21.81
240RA/250RA/540RA 20	7.63	11.91	16.47	24.27	30.12	30.75

Discharge gas capacities - kw

Valve series	Pressure drop across valve - kpa					
	13.8	34.5	69	172.5	345	690
	R-502					
100RB	0.70	0.70	1.06	1.76	2.46	2.81
150RB 1	0.70	0.70	1.06	1.76	2.46	2.81
150RB 3	1.41	2.11	2.99	4.75	6.15	7.03
150RB 7	1.93	2.99	4.22	6.33	8.26	9.85
150RB 9	3.52	5.63	7.91	11.43	15.47	20.22
200RB/500RB 2	1.41	2.11	2.99	4.75	6.15	7.03
200RB/500RB 3	1.93	2.99	4.22	6.33	8.26	9.85
200RB/500RB 4	3.52	5.63	7.91	11.43	15.47	20.22
200RB/500RB 5	4.22	6.86	9.67	13.89	19.17	25.67
200RB/500RB 6	4.57	7.21	10.20	15.47	21.10	27.08
200RB/500RB 7	5.98	9.50	13.36	21.80	29.19	36.58
240RA/250RA/540RA 8	5.98	9.50	13.36	21.80	29.19	36.58
240RA/250RA/540RA 9T5	10.20	15.83	22.51	35.17	46.77	58.03
240RA/250RA/540RA 9	12.66	20.05	28.49	43.26	56.62	66.12
240RA/250RA/540RA 12	14.07	22.51	31.65	50.64	65.77	76.32
240RA/250RA/540RA 16	23.21	36.93	52.05	80.19	106.21	130.13
240RA/250RA/540RA 20	32.71	51.35	72.80	120.63	158.26	188.86
R-513A/R-450A						
100RB	0.46	0.72	0.99	1.46	1.81	1.85
150RB 1	0.46	0.72	0.99	1.46	1.81	1.85
150RB 3	1.03	1.61	2.23	3.28	4.07	4.16
150RB 7	1.49	2.33	3.22	4.74	5.89	6.01
150RB 9	2.87	4.48	6.19	9.12	11.32	11.55
200RB/500RB 2	1.03	1.61	2.23	3.28	4.07	4.16
200RB/500RB 3	1.49	2.33	3.22	4.74	5.89	6.01
200RB/500RB 4	2.87	4.48	6.19	9.12	11.32	11.55
200RB/500RB 5	3.44	5.37	7.43	10.94	13.58	13.86
200RB/500RB 6	3.67	5.73	7.92	11.67	14.49	14.79
200RB/500RB 7	4.82	7.52	10.40	15.32	19.02	19.41
240RA/250RA/540RA 8	4.82	7.52	10.40	15.32	19.02	19.41
240RA/250RA/540RA 9T5	8.26	12.89	17.82	26.26	32.60	33.27
240RA/250RA/540RA 9	10.56	16.47	22.78	33.55	41.65	42.51
240RA/250RA/540RA 12	11.70	18.26	25.25	37.20	46.18	47.13
240RA/250RA/540RA 16	19.05	29.72	41.09	60.54	75.16	76.71
240RA/250RA/540RA 20	26.85	41.89	57.93	85.34	105.94	108.13

Valve series	Pressure drop across valve - psi				
	2	5	10	25	50
	R-744				
100RB	0.36	0.56	0.79	1.22	1.66
150RB 1	0.36	0.56	0.79	1.22	1.66
150RB 3	0.80	1.26	1.77	2.74	3.73
150RB 7	1.16	1.83	2.57	3.98	5.43
150RB 9	2.18	3.43	4.82	7.46	10.18
200RB/500RB 2	0.80	1.26	1.77	2.74	3.73
200RB/500RB 3	1.16	1.83	2.57	3.98	5.43
200RB/500RB 4	2.18	3.43	4.82	7.46	10.18
200RB/500RB 5	2.69	4.23	5.95	9.21	12.6
200RB/500RB 6	2.91	4.58	6.43	9.95	13.6
200RB/500RB 7	3.34	5.26	7.39	11.4	15.6

Valve series	Pressure drop across valve - kpa				
	13.8	34.5	69	172.5	345
	R-744				
100RB	1.25	1.97	2.77	4.28	5.83
150RB 1	1.25	1.97	2.77	4.28	5.83
150RB 3	2.81	4.43	6.22	9.63	13.13
150RB 7	4.09	6.44	9.04	14.00	19.10
150RB 9	7.67	12.07	16.95	26.25	35.82
200RB/500RB 2	2.81	4.43	6.22	9.63	13.13
200RB/500RB 3	4.09	6.44	9.04	14.00	19.10
200RB/500RB 4	7.67	12.07	16.95	26.25	35.82
200RB/500RB 5	9.45	14.89	20.91	32.38	44.18
200RB/500RB 6	10.22	16.09	22.60	35.00	47.76
200RB/500RB 7	11.75	18.51	25.99	40.25	54.92

Note: Shading indicates AHRI standard ratings  
 Note: Capacity is based on largest connection size.

# Industrial solenoid valves

Industrial Solenoid Valves are for use with air, water, and steam as well as the following list of secondary loop fluids.

Fluid	Manufacturer
Ethylene & Propylene Glycol	Various
Tyfoxit	Spauschus Associates (Distributor)
Siltherm Xlt	Dow
HFE	3m
Dowfrost	Dow
Pekasol	—
Dynalene	Dynalene

**Model number nomenclature** - Example: 202cb 1/8 b 5/3 2vvlc

Valve type	Product group	Valve type	Design series	Connection type	Body material	Port size	Elastomer code	*Coil	Sequential identifier	Customer special	Pack type
2	02	C	B	1/8"	B	1/2"	B	VLC			
2 = 2 Way 3 = 3 Way	Two Digit Product Group	C = Normally Closed O = Normally Open U = Universal (3-Way)		1/8" to 2" NPT Female	B = Brass S = Stainless Steel T = Stainless Steel with Silver Shading Band	3/64" thru 2"	B = Buna-N P = Ethylene Propylene T = PFTE w/Ethylene Propylene Gaskets V = Viton w/Ethylene Propylene Gasket	VLC = Valve Less Coil  For Valves with Coil See Coil Nomenclature on Coil Catalog Page	Blank thru -99	G = Customer Special  (Omit for Standard)	B1 = Bulk Pack  (Omit for Individual Pack)

\* Valves in catalog are shipped without solenoid coils (VLC = Valve Less Coil). See coil pages for coil selection and a complete list of voltage options.



202CB 1/8B1/8BVLC

# 202CB Series Industrial Solenoid Valves

The 202CB is a direct-acting 2-way, normally closed valve for control of air, water, and steam applications.

## Features

- Superior life with stainless steel enclosing tube
- Repair kits available
- Brass or stainless steel bodies

## Specifications

Watts.....	12 AC, 15 DC
Va Inrush.....	28
Va Holding.....	19
Maximum working pressure.....	500 psi (35 bar), 1000 psi (69 bar) 3/64" orifice only
Weight.....	1 lb
UL/CUL file number.....	MP604

### 202CB Series Industrial Solenoid Valves

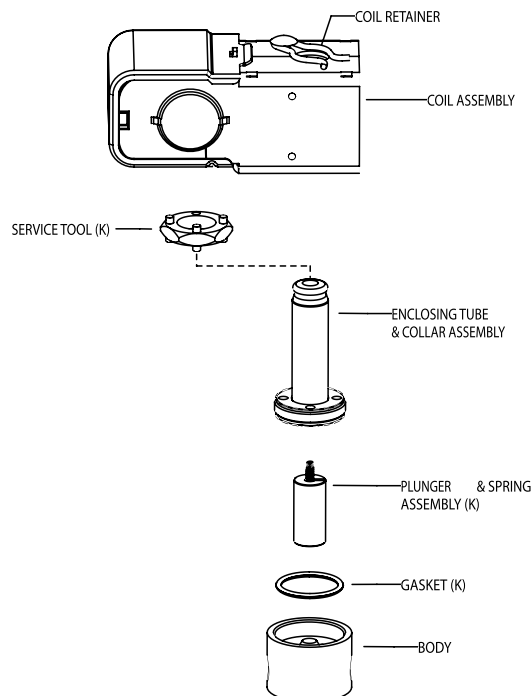
Description	Port size (in)	Conn. Size	Mopd <sup>2</sup> ac	Mopd <sup>2</sup> dc	Cv	Max. Ac fluid temp. <sup>1</sup>	Elastomer	Suggested coil	Model number	Item number
Brass General Purpose	5/32	1/8"	100	40	0.48	180°F	BUNA-N	AMG	202CB 1/8B5/32BVLC	030114
Brass Steam	5/32	1/8"	100	—	0.48	400°F	Viton w/ Ethylene Propylene Gaskets	AHG	202CB 1/8B5/32VVLC	056954
Stainless Steel General Purpose	1/16	1/8"	500	500	0.12	180°F	BUNA-N	AMG	202CB 1/8S1/16BVLC	064756

<sup>1</sup> With an ambient temperature of 77°F

<sup>2</sup> Maximum Operating Pressure Differential

VLC - See coil assemblies for availability

### Exploded view & parts kit data



**Valve repair kit**  
(K) indicates part is supplied in valve repair kit.



203CA 3/8B3/8BVLC

# 203CA Series Industrial Solenoid Valves

The 203CA is a direct-acting, 2-way normally closed valve for air, water and steam applications.

## Features

- Superior life with stainless steel enclosing tube
- Forged brass body with large wrench flats
- Repair kits available
- 3/8" NPT Solenoid Valve

## Specifications

Watts:.....	12 AC
VA Inrush:.....	37 for 5/32 & 1/8 orifices, 47 for 1/4 + orifices
VA Holding:.....	19
Maximum working pressure:.....	500 psi (35 bar)
Weight:.....	1 lb. 4 oz.
UL/CUL file number:.....	MP604

### 203CA Series Industrial Solenoid Valves

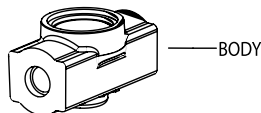
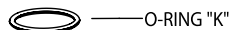
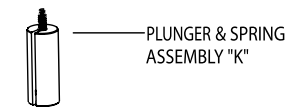
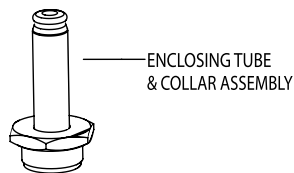
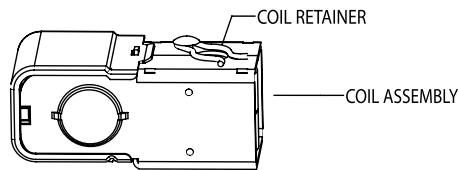
Description	Port size (in)	Connection size	Mopd <sup>2</sup> AC	CV	Max. Ac fluid temp. <sup>1</sup>	Elastomer	Suggested coil	Model number	Item number
Brass General Purpose	3/8	3/8"	10	1.7	180°F	Buna-N	AMG	203CA 3/8B3/8BVLC	030605

<sup>1</sup> With an ambient temperature of 77°F

<sup>2</sup> Maximum Operating Pressure Differential

VLC - See coil assemblies for availability

### Exploded view & parts kit data



**Valve repair kit**  
(K) indicates part is supplied in valve repair kit.

### 203CA complete valve repair kits

Seat material	Model number	Item number
Ethylene Propylene*	K-1106	040598

\* May also be used for Buna-n



204CD 1/4S1/8BVLC

# 204CD Series Industrial Solenoid Valves

The 204CD is a 2-way direct-acting unidirectional, normally closed valve for air, water and steam applications.

## Features

- Superior life with stainless steel enclosing tube
- Repair kits available
- Brass or stainless steel bodies
- 1/4" NPT Solenoid Valve

## Specifications

Watts.....	12 AC, 15 DC
VA Inrush.....	31
VA Holding.....	19
Maximum working pressure.....	500 psi (35 bar)
Weight.....	1 lb. 3 oz.
UL/CUL file number.....	MP604

### 204CD Series Industrial Solenoid Valves

Description	Port size (in)	Conn. size	Mopd <sup>2</sup> ac	Mopd <sup>2</sup> dc	Cv	Max. Ac fluid temp.	Elastomer	Suggested coil <sup>3</sup>	Model number	Item number
Brass General Purpose	3/32	1/4"	300	125	0.22	180°F	BUNA-N	AMG	204CD 1/4B3/32BVLC	030733
Brass General Purpose	1/8	1/4"	150	75	0.34	180°F	BUNA-N	AMG	204CD 1/4B1/8BVLC	056110
Brass General Purpose	5/32	1/4"	100	40	0.48	180°F	BUNA-N	AMG	204CD 1/4B5/32BVLC	030735
Brass General Purpose	1/4	1/4"	20	10	0.70	180°F	BUNA-N	AMG	204CD 1/4B1/4BVLC	030737
Brass Steam	5/32	1/4"	100	—	0.48	400°F	E.P. Seat	AMG 120V, 50/60	204CD 1/4B5/32PAMG2	064682
Stainless Steel General Purpose	3/32	1/4"	300	125	0.22	180°F	BUNA-N	AMG	204CD 1/4S3/32BVLC	030870
Stainless Steel Steam	3/64	1/4"	150	—	0.05	400°F	PTFE w/Ethylene Propylene Gaskets	AHG	204CD 1/4S3/64TVLC	030883
Stainless Steel Steam	5/32	1/4"	100	—	0.48	400°F	E.P. Seat	AMF 120V, 50/60	204CD 1/4S5/32PAMF2	053492

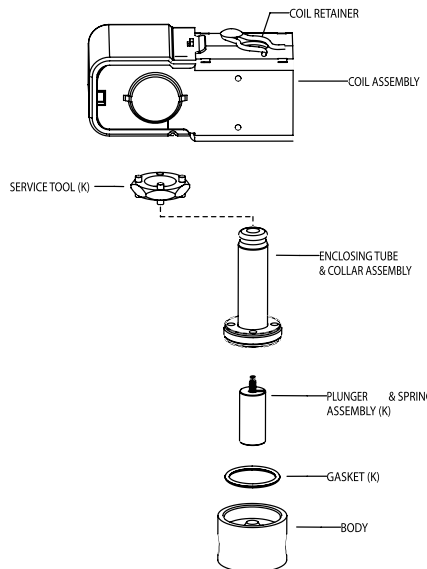
<sup>1</sup> With an ambient temperature of 77°F

<sup>2</sup> Maximum Operating Pressure Differential

<sup>3</sup> Coil is included with valve if voltage is listed

VLC - See coil assemblies for availability

### Exploded view & parts kit data



**Valve repair kit**  
(K) indicates part is supplied in valve repair kit.

### 204cd complete valve repair kits

Seat material	Model number	Item number
Buna-N	K-1072	021105
Viton	K-1074	021106
Ethylene Propylene	K-1076	032154

# 210CA / 211CA Series Industrial Solenoid Valves

The 210CA/211CA is a 2-way normally closed valve used in air, water and steam applications. The 210CA valve is pilot-operated and the 211CA valve is direct-acting.



3/8", 1/2", 3/4"



1" ONLY

## Features

- Unique captive diaphragm and seal
- Superior life with stainless steel enclosing tube
- Repair kits available

## Specifications

Watts.....	12 AC
VA Inrush.....	31
VA holding.....	19
Maximum working pressure.....	300 psi (21 bar), 250 psi (17 bar) on 1" 210C only
Weight.....	1 lbs. 3 oz.
Diaphragm operated solenoid valve pressure.....	210CA - from 5 to 150 psi (0.34 to 10 bar)
.....	3/8" to 1" NPT, 211CA - from 0 to 100 psi (0 to 7 bar) 3/8" to 3/4" NPT
UL/CUL file number.....	MP604

### 210CA Series Industrial Solenoid Valves

Description	Port size (in)	Conn. size	Mopd ac	Cv	Max. Ac fluid temp. <sup>1</sup>	Elastomer	Suggested coil	Model number	Item number
Brass General Purpose	5/8	1/2"	150	3.6	180°F	BUNA-N	AMG	210CA 1/2B5/8BVLC	030620
Brass General Purpose	5/8	3/8"	150	2.8	180°F	BUNA-N	AMG	210CA 3/8B5/8BVLC	030619
Brass General Purpose	3/4"	3/4"	125	5.5	180°F	BUNA-N	AMG	210CA 3/4B3/4BVLC	030621
Brass General Purpose	1	1"	125	13	180°F	BUNA-N	AMG	210CA 1B1BVLC	038629
Brass-Hot Water (210°F) or Steam (To 250°)	5/8	1/2"	100 <sup>2</sup> , 15 <sup>3</sup>	3.6	250°F	ETHYLENE PROPYLENE	AMG	210CA 1/2B5/8PVLC	030623
Brass-Hot Water (210°F) or Steam (To 250°)	3/4	3/4"	100 <sup>2</sup> , 15 <sup>3</sup>	5.5	250°F	ETHYLENE PROPYLENE	AMG	210CA 3/4B3/4PVLC	030624

1 With an ambient temperature of 77°F  
 2 MOPD-Hot Water  
 3 MOPD-Steam  
 VLC -See coil assemblies for availability

### 211CA Series Industrial Solenoid Valves

Description	Port size (in)	Conn. size	Mopd ac	Cv	Max. Ac fluid temp. <sup>1</sup>	Elastomer	Suggested coil	Model number	Item number
Brass General Purpose	5/8	3/8"	100	2.8	180°F	BUNA-N	AMG	211CA 3/8B5/8BVLC	030625
Brass General Purpose	5/8	1/2"	100	3.6	180°F	BUNA-N	AMG	211CA 1/2B5/8BVLC	030626
Brass General Purpose	3/4	3/4"	100	5.5	180°F	BUNA-N	AMG	211CA 3/4B3/4BVLC	030627
Brass-Hot Water (210°F) or Steam (TO 250°)	5/8	3/8"	100 <sup>2</sup> , 15 <sup>3</sup>	2.8	250°F	ETHYLENE PROPYLENE	AMG	211CA 3/8B5/8PVLC	032303
Brass-Hot Water (210°F) or Steam (TO 250°)	5/8	1/2"	100 <sup>2</sup> , 15 <sup>3</sup>	3.6	250°F	ETHYLENE PROPYLENE	AMG	211CA 1/2B5/8PVLC	032304
Brass-Hot Water (210°F) or Steam (TO 250°)	3/4	3/4"	100 <sup>2</sup> , 15 <sup>3</sup>	5.5	250°F	ETHYLENE PROPYLENE	AMG	211CA 3/4B3/4PVLC	032305

1 With an ambient temperature of 77°F  
 2 MOPD-Hot Water  
 3 MOPD-Steam  
 VLC -See coil assemblies for availability

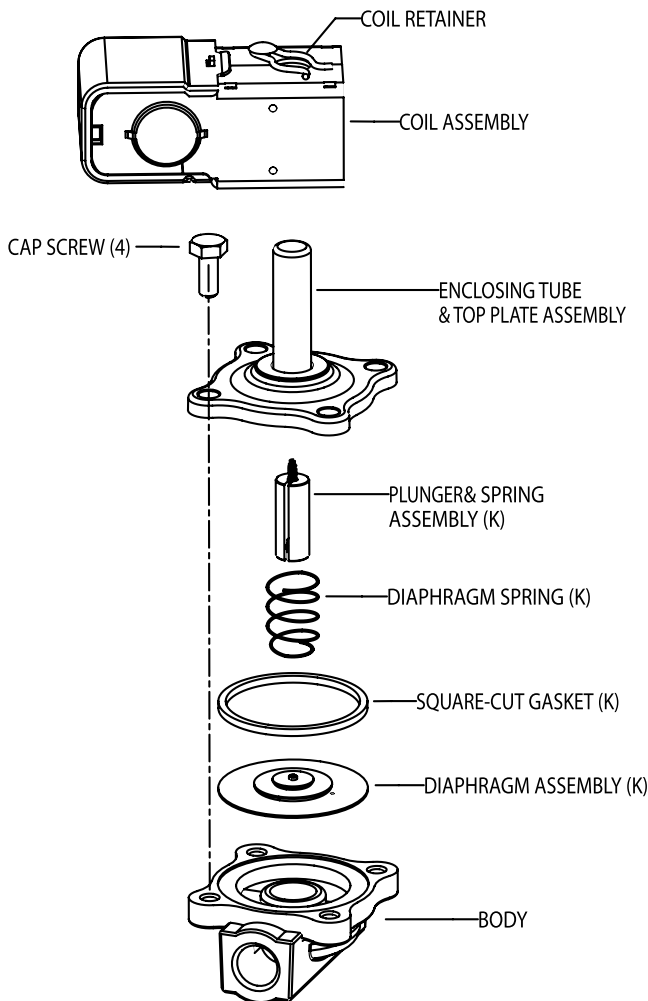
Exploded view & parts kit data

210CA complete valve repair kits

Seat material	Connection size (in)	Model number	Item number
BUNA-N	3/8 & 1/2	K-1155	028964
ETHYLENE PROPYLENE	3/8 & 1/2	K-1156	029856
BUNA-N	1	K-1177	038934
BUNA-N	3/4	K-1231	045072
ETHYLENE PROPYLENE	3/4	K-1232	045083

211CA complete valve repair kits

Seat material	Model number	Item number
BUNA-N	K-1157	034357
ETHYLENE PROPYLENE	K-1158	039879



**Valve repair kit**  
 (K) indicates part is supplied in valve repair kit.



214CB 3/8B3/8BVLC

# 214CB Series Industrial Solenoid Valves

The 214CB is a 2-way normally closed valve for air, water, and steam applications.

## Features

- Superior life with stainless steel enclosing tube
- Forged brass body with large wrench flats
- PTFE O-ring for superior external leakage
- Repair kits available

## Specifications

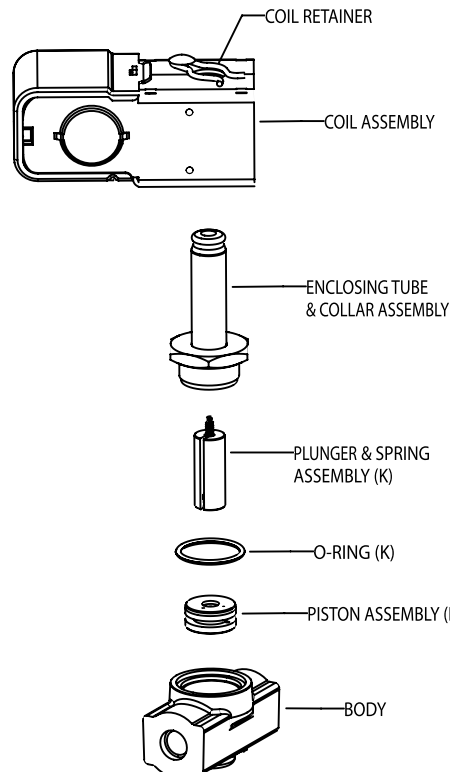
Watts.....	12 @ 60Hz
VA inrush.....	44
VA holding.....	22
Maximum working pressure.....	350 psi (24 bar)
Weight.....	1 lbs. 4 oz.
Pilot operated pressure.....	2 to 200 psi (0.15 to 14 bar)
UL/CUL file number.....	MP604

### 214CB Series Industrial Solenoid Valves

Description	Port size (in)	Connection size	Mopd <sup>2</sup> ac	Cv	Max. Ac fluid temp. <sup>1</sup>	Elastomer	Suggested coil	Model number	Item number
Brass General Purpose	1/4	1/4"	200	1.2	180°F	BUNA-N	AMG	214CB 1/4B1/4BVLC	030540
Brass General Purpose	3/8	3/8"	200	2.2	180°F	BUNA-N	AMG	214CB 3/8B3/8BVLC	030545

1 With an ambient temperature of 77°F  
 2 Maximum Operating Pressure Differential  
 VLC - See coil assemblies for availability

### Exploded view & parts kit data



#### Valve repair kit

(K) indicates part is supplied in valve repair kit.

### 214CB complete valve repair kits

Seat material	Model number	Item number
Buna-N	K-1112	035074
Ethylene Propylene	K-1113	041334



222CB 1-1/4B1-1/4BVLC

# 222CB Series Industrial Solenoid Valves

The 222CB is a 2-way normally closed valve for air, water, and steam applications.

## Features

- Forged brass body with large wrench flats
- Repair kits available

## Specifications

Seat material.....	Rulon
Watts.....	12 @ 60Hz
VA inrush.....	38
VA holding.....	19
Maximum working pressure.....	300 psi (21 bar)
Minimum operating pressure.....	5 psi (0.34 bar)
UL/CUL file number.....	MP604

### 222CB Series Industrial Solenoid Valves

Description	Port size (in)	Conn. size	Mopd <sup>2</sup> ac	Cv	Max. Ac fluid temp. <sup>1</sup>	Elastomer	Suggested coil	Model number	Item number
Brass General Purpose	1/2	1/2"	250	3.5	180°F	BUNA-N	AMG	222CB 1/2B1/2BVLC	039917
	3/4	3/4"	250	7.0	180°F	BUNA-N	AMG	222CB 3/4B3/4BVLC	028192
	1	1"	250	13.0	180°F	BUNA-N	AMG	222CB 1B1BVLC	039931
	1-1/4	1-1/4"	250	16.0	180°F	BUNA-N	AMG	222CB 1-1/4B1-1/4BVLC	039918
	1-1/2	1-1/2"	250	25.0	180°F	BUNA-N	AMG	222CB 1-1/2B1-1/2BVLC	038879
Brass Steam	1/2	1/2"	150	3.5	400°F	Rulon with Ethylene Propylene Gaskets	AHG	222CB 1/2B1/2TVLC	037958
	3/4	3/4"	150	7.0	400°F	Rulon with Ethylene Propylene Gaskets	AHG	222CB 3/4B3/4TVLC	039930
	1	1"	250	13.0	180°F	BUNA-N	AHG	222CB 1B1TVLC	039834
	1-1/4	1-1/4"	150	16.0	400°F	Rulon with Ethylene Propylene Gaskets	AHG	222CB 1-1/4B1-1/4TVLC	040532
	1-1/2	1-1/2"	150	25.0	400°F	Rulon with Ethylene Propylene Gaskets	AHG	222CB 1-1/2B1-1/2TVLC	040582

1 With an ambient temperature of 77°F  
 2 Maximum Operating Pressure Differential  
 VLC - See coil assemblies for availability

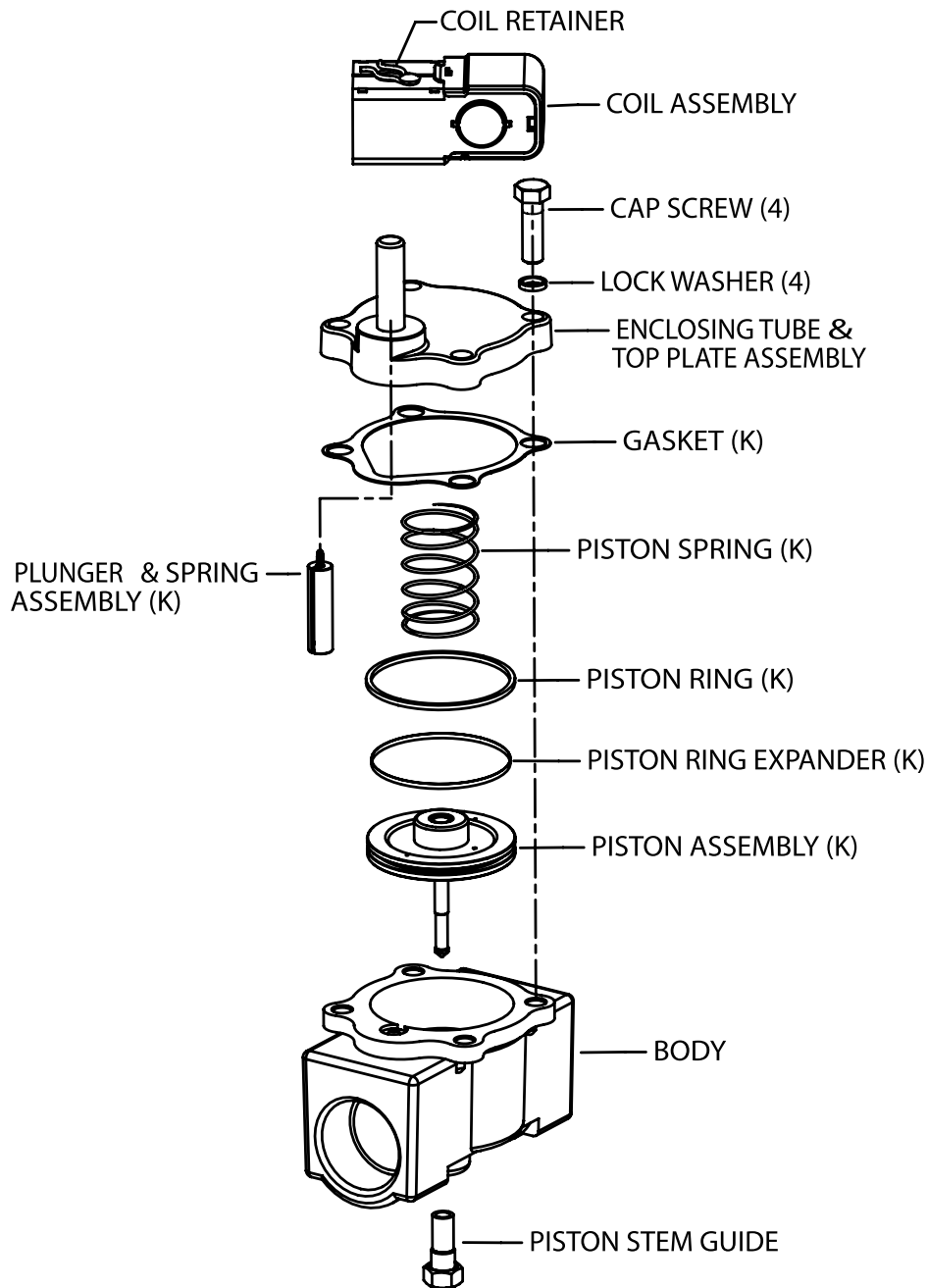
Exploded view & parts kit data

222CB complete valve repair kits

Seat material	Body size									
	3/8" & 1/2"		3/4"		1"		1-1/4"		1-1/2"	
	Model number	Item number	Model number	Item number	Model number	Item number	Model number	Item number	Model number	Item number
Buna-N	K-1116	030765	K-1120	037558	K-1124	028955	K-1128	031349	K-1132	028956
Rulon	K-1118	029235	K-1122	021109	K-1126	034178	K-1130	034047		

Valve repair kit

(K) indicates part is supplied in valve repair kit.



# Filter drier quick selection guide

## Hermetic liquid line filter driers

Series	Description	Application	Construction	Tonnages (R-410A)
EK	Premium Universal	Uni-Flow	Compacted Bead	1 to 34 tons
BSL	Builder Series (Residential)	Uni-Flow	Compacted Bead	1 to 8 tons
ADK	Standard Filter Drier	Uni-Flow	Solid Core	1 to 34 tons
BFK	Premium Heat Pump	Bi-Flow	Solid Core	1 to 26 tons
BSB	Builder Series (Residential Heat Pump)	Bi-Flow	Solid Core	3 to 5 tons
BOK	Burnout for AB or Mineral Oil	Uni-Flow	Solid Core	2 to 18 tons
CU	Copper Spun Residential	Uni-Flow	Solid Core	3 to 6 tons
ALF	Filter Only	Recovery Machines	—	Up to 8 tons

## Hermetic suction line filter driers

Series	Description	Application	Construction	Tonnages (R-410A)
ASD	Premium Universal	Uni-Flow	Beaded	2 to 21 tons
SFD	Smaller Lay-in	Uni-Flow	Beaded	4 to 8 tons
CSFD	Compact "Pancake Style"	Uni-Flow	Solid Core	2 to 9 tons
ASK	Burnout (contains Activated Carbon)	Uni-Flow	Solid Core	4 to 8 tons
BSS	Builder Series (Residential)	Uni-Flow	Solid Core	3 to 6 tons
ASF	Filter Only	Uni-Flow	—	5 to 35 tons

## Take-apart filter driers

Series	Description	Application	Core / cartridge	Tonnages (R-410A)
STAS	Steel Shell, Steel Internals	Liquid or Suction	48 Cu. In. Cores	22 to 123 tons
ADKS	Steel Shell, Plastic Internals	Liquid or Suction	100 Cu. In. Cores	110 to 180 tons (<500 psig)
BTAS	Brass Shell	Suction	Cartridges	1 to 8 tons (R-404a)



EK 083S

# EK Series Hermetic Liquid Line Filter Driers

The EK is a premium compacted bead liquid line filter designed for maximum filtration in both air conditioning and refrigeration applications.

## Features

- 99.9% filtration efficiency with minimal pressure drop
- Retains contaminants during system cycling and vibration
- Filtration first for more effective use of surface area of desiccant
- High moisture and acid removal capacity
- Specially formulated blend to protect POE oils
- Shock resistant steel shell construction
- Solid copper connections
- Compatible with common A1, A2L and A3 refrigerants

## Specifications

Desiccant ..... Blend optimized for high water and acid capacity  
 Filtration ..... 20 microns  
 Maximum working pressure ..... 680 psig (47 bar)  
 UL/CUL file number ..... SA3124  
 Canadian CRN ..... OE21971.513467890YTN

Model number nomenclature - Example: EK 083SVV

Series	Unit size	Connection size	Connection style	Access type	Sequential identifier	Customer special	Pack type
EK	08	3	S	VV			
Hermetic Liquid Line Filter Driers	In Cubic In.	In 1/8" Increments	S = ODF FM = SAE Female X SAE Male SVCAP = ODF X Cap. Tube with Access Valve MF = SAE Male X SAE Female  (Omit for SAE)	V = Single Access Valve VV = Dual Access Valve VCAP = Single Access Valve with Cap Tube Outlet Connection	Blank Thru -99	G = Customer Special  (Omit for Standard)	B1 = Bulk Pack  (Omit for Individual Pack)

## EK Series Liquid Line Filter Driers

Unit size (cubic inches)	Inlet x outlet connection size	Access type	Model number	Item number
3	1/4" X 1/4" SAE Flare	None	EK 032	060009
3	1/4" Female X 1/4" Male SAE Flare	None	EK 032FM	060011
3	1/4" Male X 1/4" Female SAE Flare	None	EK 032MF	060010
3	1/4" X 1/4" ODF	None	EK 032S	060012
3	1/4" ODF X Cap Tube	Single	EK 032SVCAP	063208
3	1/4" X 1/4" ODF	Dual	EK 032SVV	063908
3	3/8" X 3/8" SAE Flare	None	EK 033	060013
3	3/8" X 3/8" ODF	None	EK 033S	060014
5	1/4" X 1/4" SAE Flare	None	EK 052	047601
5	1/4" Male X 1/4" Female SAE Flare	None	EK 052MF	057013
5	1/4" X 1/4" ODF	None	EK 052S	047602
5	1/4" ODF X Cap Tube	Single	EK 052SVCAP	065846
5	1/4" X 1/4" ODF	Dual	EK 052SVV	065966
5	3/8" X 3/8" SAE Flare	None	EK 053	047603
5	3/8" X 3/8" ODF	None	EK 053S	047604
5	3/8" X 3/8" ODF	Dual	EK 053SVV	065963
8	1/4" X 1/4" SAE Flare	None	EK 082	047605
8	5/16" X 5/16" ODF	None	EK 0825S	049551
8	1/4" X 1/4" ODF	None	EK 082S	047606
8	3/8" X 3/8" SAE Flare	None	EK 083	047607
8	3/8" Male X 3/8" Female SAE Flare	None	EK 083MF	056906

EK Series Liquid Line Filter Driers (continued)

Unit size (cubic inches)	Inlet x outlet connection size	Access type	Model number	Item number
8	3/8" X 3/8" ODF	None	EK 083S	047608
8	3/8" X 3/8" ODF	Dual	EK 083SVV	065964
8	1/2" X 1/2" SAE Flare	None	EK 084	047609
8	1/2" X 1/2" ODF	None	EK 084S	047610
16	1/4" X 1/4" SAE Flare	None	EK 162	047611
16	5/16" X 5/16" ODF	None	EK 1625S	056045
16	1/4" X 1/4" ODF	None	EK 162S	047612
16	3/8" X 3/8" SAE Flare	None	EK 163	047613
16	3/8" X 3/8" ODF	None	EK 163S	047614
16	3/8" X 3/8" ODF	Dual	EK 163SVV	065965
16	1/2" X 1/2" SAE Flare	None	EK 164	047615
16	1/2" X 1/2" ODF	None	EK 164S	047616
16	5/8" X 5/8" SAE Flare	None	EK 165	047617
16	5/8" X 5/8" ODF	None	EK 165S	047618
16	7/8" X 7/8" ODF	None	EK 167S	047619
30	3/8" X 3/8" SAE Flare	None	EK 303	048210
30	3/8" X 3/8" ODF	None	EK 303S	048211
30	1/2" X 1/2" SAE Flare	None	EK 304	048212
30	1/2" X 1/2" ODF	None	EK 304S	048213
30	5/8" X 5/8" SAE Flare	None	EK 305	048214
30	5/8" X 5/8" ODF	None	EK 305S	048215
30	3/4" X 3/4" SAE Flare	None	EK 306	048668
30	3/4" X 3/4" ODF	None	EK 306S	048216
30	7/8" X 7/8" ODF	None	EK 307S	048217
30	1-1/8" X 1-1/8" ODF	None	EK 309S	048218
41	3/8" X 3/8" SAE Flare	None	EK 413	048219
41	1/2" X 1/2" SAE Flare	None	EK 414	048220
41	1/2" X 1/2" ODF	None	EK 414S	048221
41	5/8" X 5/8" SAE Flare	None	EK 415	048222
41	5/8" X 5/8" ODF	None	EK 415S	048223
41	7/8" X 7/8" ODF	None	EK 417S	048224
41	1-1/8" X 1-1/8" ODF	None	EK 419S	048225
75	7/8" X 7/8" ODF	None	EK 757S	048228
75	1-1/8" X 1-1/8" ODF	None	EK 759S	048229

EK series capacity table

Model number	Item number	Flow capacity tons @ 1 Psi Δp 1.4 (for kw, multiply tons by 3.5)						Water capacity 2 drops of water 3																	
								R-22		R-134a		R-290 / R-600		R-404a / R-507		R-407c		R-410a		R-450a / R-513a		R452a / R452c / R-448a / R-449a		R-744	
		R-22 /R-410a /R-448a /R-449a	R-134a /R-450a /R-513a	R-290	R-404a /R-507 /R-452a /R-452c	R-407c	R-744	78°F	125°F	78°F	125°F	78°F	125°F	78°F	125°F	78°F	125°F	78°F	125°F	78°F	125°F	14°F	75°F		
EK 032FM	060011	2.2	2.0	2.4	1.4	2.1	2.8	40	33	40	37	46	42	38	37	47	42	44	41	46	41	45	41	39	36
EK 032	060009	2.2	2.0	2.4	1.4	2.1	2.8	40	33	40	37	46	42	38	37	47	42	44	41	46	41	45	41	39	36
EK 032MF	060010	2.2	2.0	2.4	1.4	2.1	2.8	40	33	40	37	46	42	38	37	47	42	44	41	46	41	45	41	39	36
EK 032S	060012	2.9	2.7	3.2	2.0	2.9	3.7	40	33	40	37	46	42	38	37	47	42	44	41	46	41	45	41	39	36
EK 033	060013	3.3	3.0	3.6	2.2	3.2	4.3	40	33	40	37	46	42	38	37	47	42	44	41	46	41	45	41	39	36
EK 033S	060014	3.3	3.0	3.6	2.2	3.2	4.3	40	33	40	37	46	42	38	37	47	42	44	41	46	41	45	41	39	36
EK 052	047601	2.3	2.1	2.5	1.5	2.2	3.0	114	97	116	106	125	114	109	106	133	120	125	116	123	112	122	111	106	96
EK 052MF	057013	2.3	2.1	2.5	1.5	2.2	3.0	114	97	116	106	125	114	109	106	133	120	125	116	123	112	122	111	106	96
EK 052S	047602	3.6	3.3	3.7	2.4	3.5	4.6	114	97	116	106	125	114	109	106	133	120	125	116	123	112	122	111	106	96

EK series capacity table (continued)

Model number	Item number	Flow capacity tons @ 1 Psi Δp 1, 4 (for kw, multiply tons by 3.5 )						Water capacity 2 drops of water 3																	
								R-22		R-134a		R-290 / R-600		R-404a / R-507		R-407c		R-410a		R-450a / R-513a		R452a / R452c / R-448a / R-449a		R-744	
		R-22 /R-410a /R-448a /R-449a	R-134a /R-450a /R-513a	R-290	R-404a /R-507 /R-452a /R-452c	R-407c	R-744	75°F	125°F	75°F	125°F	75°F	125°F	75°F	125°F	75°F	125°F	75°F	125°F	75°F	125°F	75°F	125°F	14°F	75°F
EK 053	047603	3.8	3.5	4.2	2.5	3.7	4.9	114	97	116	106	125	114	109	106	133	120	125	116	123	112	122	111	106	96
EK 053S	047604	4.8	4.4	5.3	3.2	4.7	6.2	114	97	116	106	125	114	109	106	133	120	125	116	123	112	122	111	106	96
EK 082	047605	2.5	2.3	2.8	1.7	2.4	3.2	235	200	237	218	257	234	224	217	249	226	234	218	254	231	251	228	219	199
EK 0825S	049551	3.8	3.5	4.2	2.5	3.7	4.9	235	200	237	218	257	234	224	217	249	226	234	218	254	231	251	228	219	199
EK 082S	047606	3.4	3.3	4.0	2.2	3.3	4.4	235	200	237	218	257	234	224	217	249	226	234	218	254	231	251	228	219	199
EK 083	047607	4.3	4.0	4.7	2.9	4.3	5.5	235	200	237	218	257	234	224	217	249	226	234	218	254	231	251	228	219	199
EK 083MF	056906	4.3	4.0	4.7	2.9	4.3	5.5	235	200	237	218	257	234	224	217	249	226	234	218	254	231	251	228	219	199
EK 083S	047608	4.9	4.5	5.4	3.3	4.8	6.3	235	200	237	218	257	234	224	217	249	226	234	218	254	231	251	228	219	199
EK 084	047609	7.3	6.7	8.0	4.9	7.1	9.4	235	200	237	218	257	234	224	217	249	226	234	218	254	231	251	228	219	199
EK 084S	047610	7.7	7.1	8.5	5.1	7.5	9.9	235	200	237	218	257	234	224	217	249	226	234	218	254	231	251	228	219	199
EK 162	047611	2.5	2.3	2.8	1.7	2.4	3.2	368	313	371	341	403	366	350	340	456	413	427	399	398	361	392	357	342	311
EK 1625S	056045	3.4	3.1	3.7	2.2	3.3	4.4	368	313	371	341	403	366	350	340	456	413	427	399	398	361	392	357	342	311
EK 162S	047612	3.4	3.1	3.7	2.2	3.3	4.4	368	313	371	341	403	366	350	340	456	413	427	399	398	361	392	357	342	311
EK 163	047613	4.2	3.9	4.6	2.8	4.1	5.4	368	313	371	341	403	366	350	340	456	413	427	399	398	361	392	357	342	311
EK 163S	047614	4.8	4.4	5.3	3.2	4.7	6.2	368	313	371	341	403	366	350	340	456	413	427	399	398	361	392	357	342	311
EK 164	047615	7.8	7.2	8.6	5.2	6.5	10.1	368	313	371	341	403	366	350	340	456	413	427	399	398	361	392	357	342	311
EK 164S	047616	9.2	8.5	10.1	6.2	9.0	11.9	368	313	371	341	403	366	350	340	456	413	427	399	398	361	392	357	342	311
EK 165	047617	10.5	9.7	11.6	7.0	10.3	13.5	368	313	371	341	403	366	350	340	456	413	427	399	398	361	392	357	342	311
EK 165S	047618	10.9	10.1	12.0	7.3	10.7	14.1	368	313	371	341	403	366	350	340	456	413	427	399	398	361	392	357	342	311
EK 167S	047619	16.8	15.5	18.5	11.2	16.5	21.7	368	313	371	341	403	366	350	340	456	413	427	399	398	361	392	357	342	311
EK 303	048210	4.7	4.3	5.2	3.1	4.6	6.1	657	561	664	611	722	656	627	608	763	693	716	669	713	648	703	640	614	558
EK 303S	048211	6.8	6.3	7.5	4.6	6.7	8.8	657	561	664	611	722	656	627	608	763	693	716	669	713	648	703	640	614	558
EK 304	048212	8.8	8.1	9.7	5.9	8.6	11.4	657	561	664	611	722	656	627	608	763	693	716	669	713	648	703	640	614	558
EK 304S	048213	10.8	10.0	11.9	7.2	10.6	13.9	657	561	664	611	722	656	627	608	763	693	716	669	713	648	703	640	614	558
EK 305	048214	11.5	10.6	12.7	7.7	11.3	14.8	657	561	664	611	722	656	627	608	763	693	716	669	713	648	703	640	614	558
EK 306S	048216	16.0	14.8	17.6	10.7	15.7	20.6	657	561	664	611	722	656	627	608	763	693	716	669	713	648	703	640	614	558
EK 307S	048217	18.2	16.8	20.0	12.2	17.9	23.5	657	561	664	611	722	656	627	608	763	693	716	669	713	648	703	640	614	558
EK 309S	048218	21.2	19.6	23.3	14.2	20.8	27.3	657	561	664	611	722	656	627	608	763	693	716	669	713	648	703	640	614	558
EK 413	048219	4.7	4.3	5.2	3.1	4.6	6.1	919	785	938	854	1010	918	870	850	1064	967	999	934	997	906	984	895	859	780
EK 414	048220	11.3	10.4	12.4	7.5	11.1	14.6	919	785	938	854	1010	918	870	850	1064	967	999	934	997	906	984	895	859	780
EK 414S	048221	11.7	10.8	12.9	7.8	11.5	15.1	919	785	938	854	1010	918	870	850	1064	967	999	934	997	906	984	895	859	780
EK 415	048222	13.0	12.0	14.3	8.7	12.8	16.8	919	785	938	854	1010	918	870	850	1064	967	999	934	997	906	984	895	859	780
EK 417S	048224	22.0	20.3	24.2	14.7	21.6	28.4	919	785	938	854	1010	918	870	850	1064	967	999	934	997	906	984	895	859	780
EK 419S	048225	30.0	27.7	33.0	20.1	29.4	38.7	919	785	938	854	1010	918	870	850	1064	967	999	934	997	906	984	895	859	780
EK 757S	048228	24.1	22.2	26.5	16.1	23.6	31.1	2159	1880	2159	2019	2419	2197	2119	2019	2548	2315	2392	2236	2387	2170		2142	2056	1868
EK 759S	048229	35.4	32.7	38.9	23.7	34.8	45.7	2159	1880	2159	2019	2419	2197	2119	2019	2548	2315	2392	2236	2387	2170	2356	2142	2056	1868

<sup>1</sup> All ratings in accordance with ARI Standard 710-04. 86oF liquid refrigerant temperature  
 5°F saturated vapor temperature  
 3.1 lbs./min./ton for R-134a  
 2.9 lbs./min./ton for R-22 and R-407C  
 4.0 lbs./min./ton for R-404A/507 and R-12  
 2.7 lbs./min./ton for R-410A  
 5 Since there is currently no ARI standard for R-744, values are based on 1 ton of refrigeration  
 at 20°F liquid refrigerant temperature and -20°F saturated vapor temperature.

<sup>2</sup> Water Capacities are based on:  
 Equilibrium Point Dryness (EPD) of:  
 50 parts per million for R-134a,  
 R404-A/507, R-410A, R-407C, and R-744  
 60 parts per million for R-22  
 15 parts per million for R-12

<sup>3</sup> 20 drops of water = 1 gram = 1 cc  
<sup>4</sup> For 2 PSI ΔP, Multiply values by 1.4

Liquid refrigerant holding capacity-ounces

Unit size	R-22		R-134a		R-290		R-407c		R-410a		R-404a/R-507		R-448a/R-449a		R-450a/R-513a		R-744	
	75°F	125°F	75°F	125°F	75°F	125°F	75°F	125°F	75°F	125°F	75°F	125°F	75°F	125°F	75°F	125°F	20°F	-20°F
03	2.6	2.3	2.6	2.3	1.1	1.0	2.5	2.1	2.3	1.9	2.3	1.9	2.4	2.1	2.6	2.3	2.1	2.3
05	5.9	5.3	6.0	5.4	2.4	2.2	5.6	4.9	5.3	4.4	5.2	4.4	5.5	4.8	5.8	5.2	4.8	5.3
08	7.5	6.8	7.6	6.9	3.1	2.8	7.2	6.3	6.7	5.7	6.6	5.6	7.0	6.2	7.4	6.7	6.1	6.7
16	9.3	8.4	9.4	8.6	3.9	3.5	8.9	7.8	8.3	7.0	8.2	6.9	8.6	7.7	9.1	8.3	7.5	8.3
30	26.1	23.5	26.4	23.9	10.8	9.7	24.9	21.9	23.3	19.6	22.9	19.4	24.2	21.5	25.7	23.2	21.1	23.4
41	36.4	32.5	36.9	33.1	15.0	13.5	34.7	30.3	32.5	27.2	31.9	26.8	33.6	29.8	35.6	32.3	29.2	32.4
75	65.8	59.2	66.7	60.3	27.2	24.5	62.8	55.2	58.7	49.5	57.7	48.9	60.9	54.1	64.6	58.6	53.1	58.9



ADK 163S

# ADK Series Hermetic Liquid Line Filter Driers

The ADK is a solid core liquid line filter drier good for use in residential air conditioning and refrigeration systems.

### Features

- Solid copper connections
- High moisture and acid removal capacity
- Corrosion resistant epoxy powder paint finish

### Specifications

Desiccant blend ..... Optimized for high water and acid capacity  
 Filtration ..... 40 microns  
 Maximum working pressure ..... 680 psig (47 bar)  
 UL/CUL file number ..... SA 3124  
 Canadian CRN ..... 0E21971.513467890YTN

Model number nomenclature - Example: ADK 032SVCAP

Series	Unit size	Connection size	Connection type	Access	Sequential identifier	Customer special	Pack type
ADK	03	2	S	VCAP			
Hermetic Core Style Liquid Line Filter Driers	In Cubic In.	In 1/8" Increments	S = Solder (ODF)  Omit for Flare (SAE)	V = Single Access Valve VCAP = Single Access Valve with Cap Tube Outlet (Omit for no access valve)	Blank Thru -99	G = Customer Special  (Omit for Standard)	B1 = Bulk Pack  (Omit for Individual Pack)

### ADK Series Refrigerant Filter Driers

Unit size (cubic inches)	Inlet x outlet connection size & type	Access type	Model number	Item number
03	1/4" X 1/4" SAE	None	ADK 032	059874
03	1/4" X 1/4" ODF	None	ADK 032S	052451
03	3/8" X 3/8" SAE	None	ADK 033	023157
03	3/8" X 1/4" ODF	None	ADK 033/2S	063496
03	3/8" X 3/8" ODF	None	ADK 033S	053172
05	1/4" X 1/4" SAE	None	ADK 052	060125
05	1/4" X 1/4" ODF	None	ADK 052S	060126
05	3/8" X 3/8" SAE	None	ADK 053	060127
05	3/8" X 3/8" ODF	None	ADK 053S	060128
08	1/4" X 1/4" SAE	None	ADK 082	060129
08	1/4" X 1/4" ODF	None	ADK 082S	060130
08	3/8" X 3/8" SAE	None	ADK 083	060131
08	3/8" X 3/8" ODF	None	ADK 083S	060132
08	1/2" X 1/2" SAE	None	ADK 084	060133
08	1/2" X 1/2" ODF	None	ADK 084S	060134
16	1/4" X 1/4" SAE	None	ADK 162	059820
16	1/4" X 1/4" ODF	None	ADK 162S	059838
16	3/8" X 3/8" SAE	None	ADK 163	059839
16	3/8" X 3/8" ODF	None	ADK 163S	060795
16	1/2" X 1/2" SAE	None	ADK 164	059840
16	1/2" X 1/2" ODF	None	ADK 164S	059841
16	5/8" X 5/8" SAE	None	ADK 165	059842
16	5/8" X 5/8" ODF	None	ADK 165S	059843

ADK Series Refrigerant Filter Driers (cont'd)

Unit size (cubic inches)	Inlet x outlet connection size & type	Access type	Model number	Item number
30	3/8" X 3/8" SAE	None	ADK 303	060172
30	3/8" X 3/8" ODF	None	ADK 303S	058507
30	1/2" X 1/2" SAE	None	ADK 304	060173
30	1/2" X 1/2" ODF	None	ADK 304S	060176
30	5/8" X 5/8" SAE	None	ADK 305	060174
30	5/8" X 5/8" ODF	None	ADK 305S	060177
30	7/8" X 7/8" ODF	None	ADK 307S	060178
30	1-1/8" X 1-1/8" ODF	None	ADK 309S	060179
41	3/8" X 3/8" SAE	None	ADK 413	060182
41	1/2" X 1/2" ODF	None	ADK 414S	060185
41	5/8" X 5/8" SAE	None	ADK 415	060184
41	5/8" X 5/8" ODF	None	ADK 415S	060186
41	7/8" X 7/8" ODF	None	ADK 417S	060187
41	1-1/8" X 1-1/8" ODF	None	ADK 419S	060188
75	7/8" X 7/8" ODF	None	ADK 757S	060190
75	1-1/8" X 1-1/8" ODF	None	ADK 759S	060191

ADK series capacity table

Model number	Conn.	Flow capacity tons @ 1 psi Δp1.4 (For kw, multiply tons by 3.5)							Water capacity <sup>2</sup> (drops of water <sup>3</sup> )																	
		R-22/ r-448a/ r-449a	R-134a/ r-450a/ r-513a	R-290	R-410a	R-407c	R-404a /R-507	R-744	R-22		R-134a		R-290		R-407c		R-410a		R-404a / 507		R-448a / R-449a		R-450a / R-513a		R-744	
									75°F	125°F	75°F	125°F	75°F	125°F	75°F	125°F	75°F	125°F	75°F	125°F	75°F	125°F	75°F	125°F	14°F	75°F
ADK 032	1/4 SAE	2.1	1.9	2.3	2.1	2.0	1.4	2.7	69	63	74	68	62	59	57	46	47	36	76	72	49	45	63	57	58	64
ADK 032S	1/4 ODF	2.5	2.3	2.8	2.5	2.4	1.7	3.2																		
ADK 033	3/8 SAE	2.9	2.7	3.2	2.9	2.9	2.0	3.7																		
ADK 033S	3/8 ODF	3.3	3.0	3.6	3.3	3.2	2.2	4.3																		
ADK 052	1/4 SAE	2.2	2.0	2.4	2.2	2.1	1.4	2.8	180	130	195	180	161	152	150	120	125	95	200	190	128	116	162	147	144	169
ADK 052S	1/4 ODF	3.1	2.9	3.4	3.1	3.1	2.1	4.0																		
ADK 053	3/8 SAE	4.0	3.7	4.4	4.0	3.9	2.7	5.2																		
ADK 053S	3/8 ODF	4.9	4.5	5.4	4.9	4.8	3.3	6.3																		
ADK 082	1/4 SAE	2.2	2.0	2.4	2.2	2.1	1.4	2.8	250	225	265	245	227	214	205	165	170	130	275	260	180	164	228	207	198	233
ADK 082S	1/4 ODF	3.4	3.1	3.7	3.4	3.3	2.2	4.4																		
ADK 083	3/8 SAE	4.7	4.3	5.2	4.7	4.6	3.1	6.1																		
ADK 083S	3/8 ODF	4.6	4.2	5.1	4.6	4.5	3.0	5.9																		
ADK 084	1/2 SAE	7.3	6.7	8.0	7.3	7.1	4.9	9.4	265	330	390	360	322	304	300	240	250	190	400	380	256	233	323	294	328	386
ADK 084S	1/2 ODF	7.6	7.0	8.4	7.6	7.4	5.1	9.8																		
ADK 162	1/4 SAE	2.2	2.0	2.4	2.2	2.1	1.4	2.8																		
ADK 163	3/8 SAE	4.8	4.4	5.3	4.8	4.7	3.2	6.2																		
ADK 163S	3/8 ODF	5.3	4.9	5.8	5.3	5.2	3.6	6.8	810	740	865	800	—	—	675	540	555	420	895	845	614	558	775	705	676	796
ADK 164	1/2 SAE	9.0	8.3	9.9	9.0	8.8	6.0	11.6																		
ADK 164S	1/2 ODF	9.3	8.6	10.2	9.3	9.1	6.2	12.0																		
ADK 165	5/8 SAE	12.8	11.8	14.1	12.8	12.5	8.6	16.5																		
ADK 165S	5/8 ODF	14.2	13.1	15.6	14.2	13.9	9.5	18.3	810	740	865	800	—	—	675	540	555	420	895	845	614	558	775	705	676	796
ADK 167S	7/8 ODF	17.3	16.0	19.0	17.3	17.0	11.8	22.3																		
ADK 303	3/8 SAE	5.1	4.7	—	5.1	5.0	3.4	6.6																		
ADK 304	1/2 SAE	9.3	8.6	—	9.3	9.1	6.2	12.0																		
ADK 304S	1/2 ODF	9.5	8.8	—	9.5	9.4	6.4	12.3																		
ADK 305	5/8 SAE	15.0	13.8	—	15.0	14.7	10.0	19.4																		

ADK series capacity table (continued)

Model number	Conn.	Flow capacity tons @ 1 psi Δp1 4 (For kw, multiply tons by 3.5)							Water capacity <sup>2</sup> (drops of water <sup>3</sup> )																	
		R-22/ r-448a/ r-449a	R-134a/ r-450a/ r-513a	R-290	R-410a	R-407c	R-404a / R-507	R-744	R-22		R-134a		R-290		R-407c		R-410a		R-404a / 507		R-448a / R-449a		R-450a / R-513a		R-744	
									75°F	125°F	75°F	125°F	75°F	125°F	75°F	125°F	75°F	125°F	75°F	125°F	75°F	125°F	75°F	125°F	14°F	75°F
ADK 305S	5/8 ODF	15.7	14.5	—	15.7	15.4	10.5	20.3	810	740	865	800	—	—	675	540	555	420	895	845	614	558	775	705	676	796
ADK 306S	3/4 ODF	17.1	15.8	—	17.1	16.8	11.5	22.1																		
ADK 307S	7/8 ODF	18.9	17.4	—	18.9	18.5	12.6	24.4																		
ADK 309S	1-1/8 ODF	27.0	24.9	—	27.0	26.5	18.0	34.8																		
ADK 413	3/8 SAE	5.1	4.7	—	5.1	5.0	3.4	6.6	1140	1010	1210	1100	—	—	945	740	780	580	1260	1156	818	744	1033	1033	900	1060
ADK 414	1/2 SAE	10.6	9.8	—	10.6	10.4	7.1	13.7																		
ADK 414S	1/2 ODF	11.6	10.7	—	11.6	11.4	7.8	15.0																		
ADK 415	5/8 SAE	16.9	15.6	—	16.9	16.6	11.3	21.8																		
ADK 415S	5/8 ODF	17.9	16.5	—	17.9	17.5	12.0	23.1																		
ADK 417S	7/8 ODF	22.0	20.3	—	22.0	21.7	14.7	28.4																		
ADK 419S	1-1/8 ODF	27.3	25.2	—	27.3	26.8	18.3	35.2																		
ADK 757S	7/8 ODF	37.1	34.2	—	37.1	36.3	24.8	47.9																		
ADK 759S	1-1/8 ODF	40.4	37.3	—	40.4	39.6	27.0	52.1																		

<sup>1</sup> All ratings in accordance with ARI Standard 710-04. 86oF liquid refrigerant temperature  
 5°F saturated vapor temperature  
 3.1 lbs./min./ton for R-134a  
 2.9 lbs./min./ton for R-22 and R-407C  
 4.0 lbs./min./ton for R-404A/507 and R-12  
 2.7 lbs./min./ton for R-410A  
 5 Since there is currently no ARI standard for R-744, values are based on 1 ton of refrigeration at 20°F liquid refrigerant temperature and -20°F saturated vapor temperature.

<sup>2</sup> Water Capacities are based on:  
 Equilibrium Point Dryness (EPD) of:  
 50 parts per million for R-134a,  
 R404-A/507, R-410A, R-407C, and R-744  
 60 parts per million for R-22  
 15 parts per million for R-12

<sup>3</sup> 20 drops of water = 1 gram = 1 cc  
<sup>4</sup> For 2 PSI ΔP, Multiply values by 1.4

Liquid refrigerant holding capacity-ounces

Unit size	R-12		R-22 / r-448a / R-449a		R290		R-134a / r-450a /R-513a		R-407c		R-410a		R-404a / 507		R-502		R-744	
	75°F	125°F	75°F	125°F	75°F	125°F	75°F	125°F	75°F	125°F	75°F	125°F	75°F	125°F	75°F	125°F	20°F	-20°F
03	2.4	2.2	2.2	2.0	0.9	0.8	2.2	2.0	2.1	1.9	2.0	1.7	1.9	1.7	2.7	2.3	1.8	2.0
05	5.9	6.0	5.4	5.4	2.2	2	5.5	5.5	5.2	5.0	4.8	4.5	4.7	4.5	6.0	5.3	4.9	5.4
08	8.0	7.4	7.3	6.6	3	2.7	7.4	6.7	7.0	6.2	6.5	5.5	6.4	5.5	7.7	6.8	5.9	6.5
16	14.5	12.5	13.2	11.2	5.4	4.9	13.4	11.4	12.6	10.4	11.7	9.4	11.6	9.3	9.5	8.4	10.1	11.2
30	21.8	19.9	19.8	17.8	8.1	7.3	20.1	18.1	18.9	16.6	17.4	14.9	17.4	14.7	26.7	23.4	16.0	17.7
41	29.3	26.8	26.6	23.9	11	9.9	26.9	24.4	25.4	22.3	23.7	20.0	23.3	19.7	37.2	32.4	21.4	23.8
75	52.8	48.3	48.0	43.1	19.8	17.9	48.6	43.9	45.8	40.2	42.8	36.0	42.1	35.6	67.2	59.0	38.7	42.9



**BFK 083S**

# BFK Series Hermetic Liquid Line Bi-Directional Filter Driers

The BFK is a liquid line filter drier for heat pump applications.

### Features

- Available 5 to 30 Cubic In. size
- Internal check valve allows flow and filtration in either direction eliminating the need for external check valves
- High moisture and acid removal capacity
- Corrosion resistant epoxy powder paint finish
- Approved for POE oils

### Specifications

Desiccant blend ..... Optimized for high water and acid capacity  
 Filtration ..... 40 microns  
 Maximum working pressure ..... 680 psig (47 bar)  
 UL/CUL file number ..... SA3124  
 Canadian CRN ..... OE21971.513467890YTN

**Model number nomenclature - Example: BFK 165S**

Series	Unit size	Connection size	Connection style	Sequential identifier	Customer special	Pack type
BFK	16	5	S			
Hermetic Liquid Line Bi-Directional Filter Driers	In Cubic In.	In 1/8" Increments	S = ODF	Blank Thru -99	G = Customer Special (Omit for Standard)	B1 = Bulk Pack (Omit for Individual Pack)

### BFK Bi-Directional Liquid Line Filter Driers

Unit size (cubic inches)	Inlet x outlet connection size	Model number	Item number
5	1/4" X 1/4" SAE	BFK 052	062300
5	1/4" X 1/4" ODF	BFK 052S	062425
5	3/8" X 3/8" SAE	BFK 053	062254
5	3/8" X 3/8" ODF	BFK 053S	062255
8	3/8" X 3/8" SAE	BFK 083	043321
8	3/8" X 3/8" ODF	BFK 083S	043323
8	1/2" X 1/2" SAE	BFK 084	043325
8	1/2" X 1/2" ODF	BFK 084S	043327
8	5/8" X 5/8" ODF	BFK 085S	043730
16	3/8" X 3/8" SAE	BFK 163	043330
16	3/8" X 3/8" ODF	BFK 163S	043333
16	1/2" X 1/2" SAE	BFK 164	043335
16	1/2" X 1/2" ODF	BFK 164S	043337
16	5/8" X 5/8" SAE	BFK 165	043732
16	5/8" X 5/8" ODF	BFK 165S	043734
16	7/8" X 7/8" ODF	BFK 167S	058589
30	3/8" X 3/8" ODF	BFK 303S	063077
30	1/2" X 1/2" SAE	BFK 304	063078
30	1/2" X 1/2" ODF	BFK 304S	063079
30	5/8" X 5/8" SAE	BFK 305	063080
30	5/8" X 5/8" ODF	BFK 305S	063081
30	3/4" X 3/4" ODF	BFK 306S	063083
30	7/8" X 7/8" ODF	BFK 307S	063084
30	1-1/8" X 1-1/8" ODF	BFK 309S	063451

BFK series capacity table

Model number	Connection	Flow capacity tons @ 1 psi Δp 1, 4 (for kw, multiply tons by 3.5)				Water capacity 2 Drops of water 3											
		R-22		R-410a		R-407c		R-744		R-22		R-407c		R-410a		R-744	
		75°F	125°F	75°F	125°F	75°F	125°F	75°F	125°F	75°F	125°F	14°F	75°F	75°F	125°F	14°F	75°F
BFK-05 2	1/4 SAE	1.6	1.6	1.6	2.1	73	66	58	42	39	35	81	89				
BFK-05 2S	1/4 ODF	2.2	2.2	2.2	2.8												
BFK-05 3	3/8 SAE	3.5	3.5	3.4	4.5												
BFK-05 3S	3/8 ODF	4.0	4.0	3.9	5.2												
BFK-08 3	3/8 SAE	4.5	4.5	4.4	5.8	159	144	106	79	85	75	136	150				
BFK-08 3S	3/8 ODF	5.1	5.1	5.0	6.6												
BFK-08 4	1/2 SAE	6.4	6.4	6.3	8.3												
BFK-08 4S	1/2 ODF	6.7	6.7	6.6	8.6												
BFK-08 5	5/8 SAE	7.2	7.2	7.0	9.3												
BFK-08 5S	5/8 ODF	8.1	8.1	7.9	10.4												
BFK-16 3	3/8 SAE	4.6	4.6	4.5	5.9	323	294	237	179	178	160	221	260				
BFK-16 3S	3/8 ODF	5.2	5.2	5.1	6.7												
BFK-16 4	1/2 SAE	7.7	7.7	7.6	9.9												
BFK-16 4S	1/2 ODF	8.1	8.1	7.9	10.4												
BFK-16 5	5/8 SAE	8.3	8.3	8.1	10.7												
BFK-16 5S	5/8 ODF	8.7	8.7	8.5	11.2												
BFK-30 3S	3/8 ODF	5.8	5.8	5.7	7.5	585	532	452	345	415	293	453	533				
BFK-30 4	1/2 SAE	7.6	7.6	7.5	9.8												
BFK-30 4S	1/2 ODF	9.7	9.7	9.5	12.5												
BFK-30 5	5/8 SAE	10.3	10.3	10.1	13.3												
BFK-30 5S	5/8 ODF	14.2	14.2	13.9	18.3												
BFK-30 6S	3/4 ODF	16.0	16.0	15.7	20.6												
BFK-30 7S	7/8 ODF	16.7	16.7	16.4	21.5												
BFK-30 9S	1 1/8 ODF	18.0	18.0	17.5	23.2												

<sup>1</sup> All ratings in accordance with ARI Standard 710-04. 86oF liquid refrigerant temperature  
 5°F saturated vapor temperature  
 3.1 lbs./min./ton for R-134a  
 2.9 lbs./min./ton for R-22 and R-407C  
 4.0 lbs./min./ton for R-404A/507 and R-12  
 2.7 lbs./min./ton for R-410A  
 5 Since there is currently no ARI standard for R-744, values are based on 1 ton of refrigeration at 20°F liquid refrigerant temperature and -20°F saturated vapor temperature.

<sup>2</sup> Water Capacities are based on:  
 Equilibrium Point Dryness (EPD) of:  
 50 parts per million for R-134a,  
 R404-A/507, R-410A, R-407C, and R-744  
 60 parts per million for R-22  
 15 parts per million for R-12

<sup>3</sup> 20 drops of water = 1 gram = 1 cc  
<sup>4</sup> For 2 PSI ΔP, Multiply values by 1.4

Liquid refrigerant holding capacity-ounces

Unit size	R-22		R-407c		R-410a		R-744	
	75°F	125°F	75°F	125°F	75°F	125°F	20°F	-20°F
05	4.6	4.2	4.4	3.9	4.1	3.5	3.7	4.1
08	7.7	6.9	7.3	6.4	6.9	5.8	6.2	6.9
16	14.2	12.7	13.5	11.8	12.6	10.6	1.4	12.7
30	21.0	18.7	20.0	17.4	19.6	16.5	16.8	18.7



**BSL 0835S**



**BSB 083S**



**BSS 167S**

# Builder Series Hermetic Filter Driers

The Builder Series is a hermetic filter drier that provides economical system protection for air conditioning and heat pump applications.

## Features

- ODF solid copper connections for easy install
- Desiccant blend optimized for high water and acid capacity
- Corrosion resistant epoxy powder paint finish
- BSB and BSS feature solid core construction
- BSL features compacted bead construction with 20 micron filtration for maximum moisture and acid removal while protecting POE oil
- BSL filters at both the inlet and outlet and retains contaminants during system cycling and vibration

## Specifications

Desiccant blend ..... Optimized for high water capacity and acid capacity  
 Maximum working pressure ..... 680 psig (47 bar)  
 UL/CUL file number ..... SA 7175  
 Filtration ..... 40 microns (BSB and BSS only)  
 ..... 20 microns (BSL only)  
 Canadian CRN ..... 0E21971.513467890YTN

*Model number nomenclature - Example: BSB 083S*

Series	Type	Unit size	Connection size	Connection style	Sequential identifier	Customer special	Pack type
BS	B	08	3	S			
Hermetic Filter Driers	B = Bi-Directional L = Liquid S = Suction	In Cubic In.	In 1/8" Increments	S = ODF  (Omit for SAE)	Blank Thru -99	G = Customer Special  (Omit for Standard)	B1 = Bulk Pack  (Omit for Individual Pack)

### Builder Series Hermetic Filter Driers

Line type	Unit size (cubic inches)	Inlet x outlet connection size	Water capacity drops r-410a @ 125°f	Flow capacity tons r-410a	Model number	Item number
Liquid	5	3/8" X 3/8" ODF	56	5.3	BSL 053S	066758
Liquid	8	3/8" X 3/8" ODF	108	5.3	BSL 083S	066759
Liquid	8	1/2" X 1/2" ODF	108	7.6	BSL 084S	066760
Liquid	16	3/8" X 3/8" ODF	151	5.3	BSL 163S	066761
Liquid	16	1/2" X 1/2" ODF	151	7.6	BSL 164S	066763
Bi-Directional	8	3/8" X 3/8" ODF	70	5.1	BSB 083S	066130
Bi-Directional	16	3/8" X 3/8" ODF	125	5.1	BSB 163S	066131
Suction	16	5/8" X 5/8" ODF	51	3.5	BSS 165S	066126
Suction	16	3/4" X 3/4" ODF	51	4.2	BSS 166S	066127
Suction	16	7/8" X 7/8" ODF	51	4.2	BSS 167S	066128
Suction	30	3/4" X 3/4" ODF	84	5.5	BSS 306S	066101
Suction	30	7/8" X 7/8" ODF	84	6.0	BSS 307S	066129
Suction	30	1-1/8" X 1-1/8" ODF	84	6.2	BSS 309S	066102



BOK 304SHH

# BOK Series Hermetic Liquid Line Filter Driers

The BOK is a liquid line filter drier for burnout clean-up and wax removal.

## Features

- Activated carbon blend for soluble contaminant and wax removal
- Solid copper connections
- Corrosion resistant epoxy powder paint finish

## Specifications

Filtration ..... 40 microns  
 Maximum working pressure ..... 680 psig (47 bar)  
 UL/CUL file number ..... SA3124  
 Canadian CRN ..... OE21971.513467890YTN

### Model number nomenclature - Example: BOK 305S-HH

Series	Unit size	Connection size	Connection style	Desiccant type	Sequential identifier	Customer special	Pack type
BOK	30	5	S	HH			
Hermetic Liquid Line Filter Driers	In Cubic In.	In 1/8" Increments	S = ODF	HH = Activated Carbon	Blank Thru -99	G = Customer Special (Omit for Standard)	B1 = Bulk Pack (Omit for Individual Pack)

### BOK Liquid Line Filter Driers & capacity table

Model number	Item number	Unit size (cubic inches)	Inlet X outlet Conn. Size	Flow capacity <sup>1,4</sup> Tons @ 1 psi Δp (for kw, multiply tons by 3.5)						Water capacity <sup>2</sup> drops of water <sup>3</sup>																
				R-22 / R-448a / R-448a	R-134a / R-450a / R-513a	R-404a / R-507	R-407c	R-410a	R-744	R-22		R-134a		R-404a / R-507		R-407c		R-410a		R-448a / R-449a		R-450a / R-513a		R-744		
										75°F	125°F	75°F	125°F	75°F	125°F	75°F	125°F	75°F	125°F	75°F	125°F	75°F	125°F	14°F	75°F	
BOK 082HH	060223	8	1/4" X 1/4" SAE	1.6	1.5	1.1	1.6	1.6	2.1	78	59	88	71	93	71	74	45	66	38	32	30	40	37	51	63	
BOK 082SHH	064591	8	1/4" X 1/4" ODF	3.4	3.1	2.2	3.3	3.4	4.4																	
BOK 083HH	060224	8	3/8" X 3/8" SAE	4.2	3.9	2.8	4.1	4.2	5.4																	
BOK 083SHH	064572	8	3/8" X 3/8" ODF	4.6	4.2	3.0	4.5	4.6	5.9	153	117	171	141	182	141	91	56	77	41	67	61	83	76	93	113	
BOK 162HH	060240	16	1/4" X 1/4" SAE	1.6	1.5	1.1	1.6	1.6	2.1																	
BOK 163HH	060241	16	3/8" X 3/8" SAE	4.7	4.3	3.1	4.6	4.7	6.1																	
BOK 163SHH	060242	16	3/8" X 3/8" ODF	6.3	5.8	4.2	6.2	6.3	8.1	267	204	300	245	318	247	234	146	160	94	119	108	148	135	167	203	
BOK 164HH	060228	16	1/2" X 1/2" SAE	9.3	8.6	6.2	9.1	9.3	12.0																	
BOK 164SHH	060229	16	1/2" X 1/2" ODF	11.1	10.2	7.4	10.9	11.1	14.3																	
BOK 165HH	060230	16	5/8" X 5/8" SAE	13.9	12.8	9.3	13.6	13.9	17.9	267	204	300	245	318	247	234	146	160	94	119	108	148	135	167	203	
BOK 165SHH	060231	16	5/8" X 5/8" ODF	13.9	12.8	9.3	13.6	13.9	17.9																	
BOK 303HH	060232	30	3/8" X 3/8" SAE	4.7	4.3	3.1	4.6	4.7	6.1																	
BOK 304HH	060233	30	1/2" X 1/2" SAE	10.7	9.9	7.2	10.5	10.7	13.8	267	204	300	245	318	247	234	146	160	94	119	108	148	135	167	203	
BOK 304SHH	060234	30	1/2" X 1/2" ODF	11.7	10.8	7.8	11.5	11.7	15.1																	
BOK 305HH	060235	30	5/8" X 5/8" SAE	14.6	13.5	9.8	14.3	14.6	18.8																	
BOK 305SHH	060236	30	5/8" X 5/8" ODF	15.8	14.6	10.6	15.5	15.8	20.4																	

*BOK Liquid Line Filter Driers & capacity table (continued)*

Model number	Item number	Unit size (cubic inches)	Inlet X outlet Conn. Size	Flow capacity <sup>14</sup> Tons @ 1 psi Δp (for kw, multiply tons by 3.5)							Water capacity <sup>2</sup> drops of water <sup>3</sup>														
				R-22 / r-448a / r-449a	R-134a / r-450a / r-513a	R-404a / r-507	R-407c	R-410a	R-744	R-22		R-134a		R-404a / R-507		R-407c		R-410a		R-448a / R-449a		R-450a / R-513a		R-744	
										75°F	125°F	75°F	125°F	75°F	125°F	75°F	125°F	75°F	125°F	75°F	125°F	75°F	125°F	75°F	125°F
BOK 414HH	060237	41	1/2" X 1/2" SAE	11.1	10.2	7.4	10.9	11.1	14.3																
BOK 415HH	060238	41	5/8" X 5/8" SAE	17.7	16.3	11.8	17.4	17.7	22.8																
BOK 415SHH	064593	41	5/8" X 5/8" ODF	17.7	16.3	14.4	21.1	17.7	22.8	379	282	427	344	454	342	256	155	220	125	163	150	204	186	249	305
BOK 417SHH	060239	41	7/8" X 7/8" ODF	21.5	19.8	14.4	21.1	21.5	27.7																

<sup>1</sup> All ratings in accordance with ARI Standard 710-04. 86oF liquid refrigerant temperature  
 5°F saturated vapor temperature  
 3.1 lbs./min./ton for R-134a  
 2.9 lbs./min./ton for R-22 and R-407C  
 4.0 lbs./min./ton for R-404A/507 and R-12  
 2.7 lbs./min./ton for R-410A  
 5 Since there is currently no ARI standard for R-744, values are based on 1 ton of refrigeration at 20°F liquid refrigerant temperature and -20°F saturated vapor temperature.

<sup>2</sup> Water Capacities are based on:  
 Equilibrium Point Dryness (EPD) of:  
 50 parts per million for R-134a,  
 R404-A/507, R-410A, R-407C, and R-744  
 60 parts per million for R-22  
 15 parts per million for R-12

<sup>3</sup> 20 drops of water = 1 gram = 1 cc  
 4 For 2 PSI ΔP, Multiply values by 1.4

*Liquid refrigerant holding capacity-ounces*

Unit size	R-134a		R-22		R-407C		R-410A		R-404A / 507		R-448A / R-449A		R-450A / R-513A		R-744	
	75°F	125°F	75°F	125°F	75°F	125°F	75°F	125°F	75°F	125°F	75°F	125°F	75°F	125°F	20°F	-20°F
08	6.7	6.0	6.6	5.9	6.3	5.5	5.9	4.9	5.8	4.9	6.0	5.4	6.4	5.8	5.3	5.9
16	12.8	11.5	12.6	11.3	12.0	10.5	11.2	9.4	11.1	9.3	11.7	10.4	12.4	11.2	10.1	11.3
30	20.1	18.1	19.8	17.8	18.9	16.6	17.6	14.9	17.4	14.7	18.3	16.3	19.4	17.6	16.0	17.7
41	26.9	24.4	26.6	23.9	25.4	22.3	23.7	20.0	23.3	19.7	24.5	21.8	26.1	23.6	21.4	23.8





ALF 032MF

# ALF Series Hermetic Liquid Line Filters

The ALF is a liquid line refrigerant filter for recovery, recycle and reclaim usage. The ALF is also used for protecting solenoid and expansion valve parts from debris.

## Features

- Filtering media maximizes removal of finer particles
- Corrosion resistant epoxy powder paint finish

## Specifications

Filtration .....40 microns  
 Maximum working pressure .....680 psig (47 bar)  
 UL/CUL file number.....SA 3124  
 Canadian CRN.....OE21971.513467890YTN

### Model number nomenclature - Example: ALF 032S

Series	Unit size	Connection size	Connection style	Sequential identifier	Customer special	Pack type
ALF	03	2	S			
Hermetic Liquid Line Filters	In Cubic In.	In 1/8" Increments	S = ODF MF = ODM x ODF (Omit for SAE)	Blank Thru -99	G = Customer Special  (Omit for Standard)	B1 = Bulk Pack  (Omit for Individual Pack)

### ALF Liquid Line Filters

Unit size (cubic inches)	Inlet x outlet connection size	Model number	Item number
3	1/4" SAE Male X 1/4" SAE Flare Female	ALF 032MF	057193
3	1/4" X 1/4" ODF	ALF 032S	056618
3	3/8" X 3/8" ODF	ALF 033S	057140
3	1/2" X 1/2" ODF	ALF 034S	056645

### Capacity table

Recovery, recycle and reclaim refrigerant flow capacity (lbs./Min. Liquid)		
R-134A / R-450A / R-513A	R-22 / R-410A / R-448A / R-449A	R-404A / R-507
7.6	8.0	8.0



STAS 9617T

# STAS Series Take-Apart Liquid and Suction Filter Driers

The STAS is a replaceable core filter drier for use in large commercial air conditioning and refrigeration systems. The STAS-CO is specifically designed for CO<sub>2</sub> (R-744) systems.

## Features

- Slotted cover/unique internal hardware for hassle-free installation
- Full flow fittings for low pressure drop
- Corrosion resistant epoxy powder paint finish
- Sturdy steel shells for long life
- Solid copper connections
- 100 mesh outlet screen

## Specifications

Filtration ..... 40 microns with core  
 Maximum working pressure ..... SV version = 500 psig (35 bar)  
 ..... T version = 680 psig (47 bar)  
 UL/CUL file number ..... SA7175  
 Canadian CRN ..... 0E21971.513467890YTN

Model number nomenclature - Example: STAS CO489T

Series	Design	Unit size	Connection size	System service	Sequential identifier	Customer special	Pack type
STAS	CO	48	9	T	VV		
Steel Take-Apart Liquid or Suction Filter Driers	CO = For use with R-744 (Omit for Standard Refrigerants)	In Cubic In.	In 1/8" Increments	T = Liquid Line Service SV = Suction Line Service	Blank Thru -99	G = Customer Special (Omit for Standard)	B1 = Bulk Pack (Omit for Individual Pack)

## STAS Series Liquid and Suction Line Filter Driers

(STAS uses 48 cubic in. Cores and shipped without filter or filter drier cores. See filter drier cores and filters section)

Unit size (cubic inches)	Inlet x outlet connection size	Access type	Number of 48 in. Cores	Model number	Item number
48	5/8" X 5/8" ODF	Tap Access	1	STAS 485T	053001
48	5/8" X 5/8" ODF	Tap Access	1	STAS CO485T	066725
48	7/8" X 7/8" ODF	Tap Access	1	STAS 487T	053003
48	7/8" X 7/8" ODF	Tap Access	1	STAS CO487T	066726
48	1-1/8" X 1-1/8" ODF	Tap Access	1	STAS 489T	053005
48	1-3/8" X 1-3/8" ODF	Single	1	STAS 4811SV	053938
48	1-3/8" X 1-3/8" ODF	Tap Access	1	STAS 4811T	053007
48	1-5/8" X 1-5/8" ODF	Single	1	STAS 4813SV	053043
48	1-5/8" X 1-5/8" ODF	Tap Access	1	STAS 4813T	053375
48	2-1/8" X 2-1/8" ODF	Single	1	STAS 4817SV	053044
48	2-5/8" X 2-5/8" ODF	Single	1	STAS 4821SV	053045
96	7/8" X 7/8" ODF	Tap Access	2	STAS 967T	053010
96	1-1/8" X 1-1/8" ODF	Tap Access	2	STAS 969T	053012
96	1-3/8" X 1-3/8" ODF	Tap Access	2	STAS CO9611T	066729
96	1-3/8" X 1-3/8" ODF	Tap Access	2	STAS 9611T	053014

STAS Series Liquid And Suction Line Filter Driers (continued)

Unit size (cubic inches)	Inlet x outlet connection size	Access type	Number of 48 in. Cores	Model number	Item number
96	1-5/8" X 1-5/8" ODF	Tap Access	2	STAS 9613T	053017
96	2-1/8" X 2-1/8" ODF	Single	2	STAS 9617SV	053047
96	2-1/8" X 2-1/8" ODF	Tap Access	2	STAS 9617T	053018
96	2-5/8" X 2-5/8" ODF	Single	2	STAS 9621SV	053048
96	3-1/8" X 3-1/8" ODF	Single	2	STAS 9625SV	059739
144	1-1/8" X 1-1/8" ODF	Tap Access	3	STAS 1449T	053020
144	1-3/8" X 1-3/8" ODF	Tap Access	3	STAS 14411T	053022
144	1-5/8" X 1-5/8" ODF	Tap Access	3	STAS 14413T	053024
144	2-1/8" X 2-1/8" ODF	Tap Access	3	STAS 14417T	053025
192	1-3/8" X 1-3/8" ODF	Tap Access	4	STAS 19211T	053028
192	1-5/8" X 1-5/8" ODF	Tap Access	4	STAS 19213T	053030
192	2-1/8" X 2-1/8" ODF	Tap Access	4	STAS 19217T	053031

SV style includes stainless steel bolts and access valve  
 T style can be used for suction by removing pipe plug and installing x-11562-2

STAS series parts list

Description	Model number	Item number
STAS Steel Liquid and Suction Line Filter Drier Cover Bolts (Stainless Steel - Suction Line service)	X-25787-7	053121
STAS Felt Set	27394-1	060278
STAS Steel Liquid and Suction Line Filter Drier Gasket Set	X-11983-1	027453
STAS Handle	26446-1	053812
STAS Steel Liquid and Suction Line Filter Drier Mounting Bracket	X-28747-1	061715
STAS Spring	26439-1	060258
BTAS and STAS Suction Line Filter Drier Access Valve with Cap (V-Option)	X-11562-2	037409
STAS Inlet Retainer	26447-1	053813
STAS Steel Liquid and Suction Line Filter Drier Retainer Assembly for 48 cu. In.	X-27458-1	060274
STAS Steel Liquid and Suction Line Filter Drier Retainer Assembly for 96 cu. In.	X-27458-2	060275
STAS Steel Liquid and Suction Line Filter Drier Retainer Assembly for 144 cu. In.	X-27458-3	060276
STAS Steel Liquid and Suction Line Filter Drier Retainer Assembly for 192 cu. In.	X-27458-4	060277
STAS Flange cover assembly includes flange cover, compression spring, pipe plug and grade 5 bolts	X-12176-3	054046
Replacement Filter (Suction Only) for ADKS and Similar Competitive Filters Not for BTAS	F 100	095762
Replacement Filter (Suction Only) Reverse Flow for STAS and Similar Competitive Filters Not for BTAS	F 48R	047664
Filter Drier Core for High Acid and Water Removal in ADKS and STAS Shells and Similar Competitive Take-Apart Filter Drier Shells Not for BTAS	H 100	089338
Block Filter Drier Core for High Acid and Water Removal in STAS Shells and Similar Competitive Take-Apart Filter Drier Shells Not for BTAS	H 48	059542
Filter Drier Core for Highest Water Removal in STAS Shells and Similar Competitive Take-Apart Filter Drier Shells Not for BTAS	HX 48	062549
Universal Replacement Cores, Filter Cores Use In STAS Shells and Similar Competitive Take-Apart Filter Drier Shells. May Not Be Used for BTAS.	RW 48	061238
Premium Universal Replacement Filter Drier Core for ADKS Shells and Similar Competitive Take-Apart Filter Drier Shells Not for BTAS	UK 100	062424
Premium Universal Replacement Filter Drier Core for STAS Shells and Similar Competitive Take-Apart Filter Drier Shells Not for BTAS	UK 48	061617
Burnout Clean Up Filter Drier Core for ADKS Shells and Similar Competitive Take-Apart Filter Drier Shells Not for BTAS	W 100HH	043582
Burnout Clean Up Filter Drier Core for STAS Shells and Similar Competitive Take-Apart Filter Drier Shells Not for BTAS	W 48HH	061235



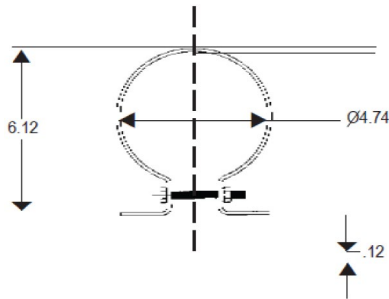
Capacity tables

STAS series capacity table

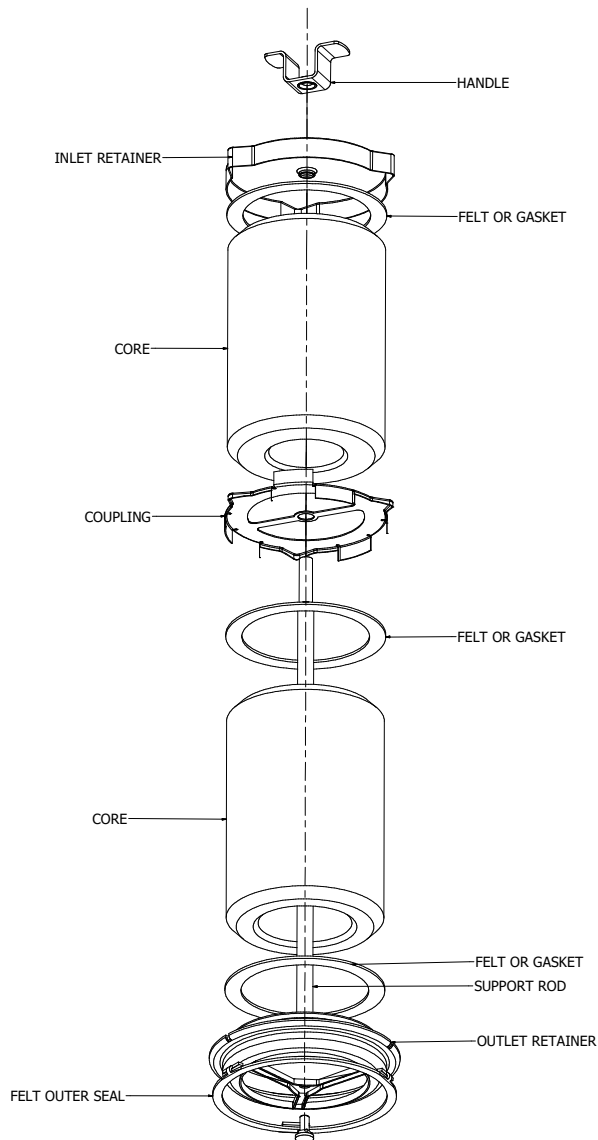
Connections	Liquid flow capacity tons @ 1 psi $\delta$ p'						Model number	Item number
	R-22 / R-410A / R-448A / R-449A	R-134A / R-450A / R-513A	R-404A / 507	R-407C	R-454B	R-744		
5/8 ODF	22	21	15	21	26	28	STAS 485T	053001
7/8 ODF	41	38	27	39	49	53	STAS 487T	053003
1-1/8 ODF	58	53	38	56	69	75	STAS 489T	053005
1-3/8 ODF	81	75	53	78	96	—	STAS 4811T	053007
1-5/8 ODF	89	81	58	85	106	—	STAS 4813T	053375
7/8 ODF	45	42	30	43	54	—	STAS 967T	053010
1-1/8 ODF	71	65	47	68	84	92	STAS 969T	053012
1-3/8 ODF	87	80	57	83	104	112	STAS 9611T	053014
1-5/8 ODF	100	92	65	95	119	—	STAS 9613T	053017
1-1/8 ODF	72	66	47	69	86	—	STAS 1449T	053020
1-3/8 ODF	100	92	65	96	119	—	STAS 14411T	053022
1-5/8 ODF	101	93	66	97	120	—	STAS 14413T	053024
2-1/8 ODF	120	110	78	115	143	—	STAS 14417T	053025
1-1/8 ODF	102	94	67	98	121	—	STAS 19211T	053028
1-5/8 ODF	113	103	74	108	134	—	STAS 19213T	053030
2-1/8 ODF	123	113	80	117	146	—	STAS 19217T	053031

All ratings in accordance with ARI standard 710-04. 86oF liquid refrigerant temperature.

- 5F saturated vapor temperature
- 3.1 lbs./min./ton for R-134a
- 2.9 lbs./min./ton for R-22 and R-407C
- 4.0lbs./min./ton for R-404A/507 and R-12
- For 2 PSI (triangle)P, Multiply values by 1.4
- For kW, multiply by 3.5\*



**Mounting Bracket for STAS 48\***  
 \* More than one mounting bracket may be required for shell sizes 96 and above.





ADKS 30017T

# ADKS Series Take-Apart Liquid & Suction Line Filters Driers

The ADKS is a replaceable core filter drier for use in the liquid or suction line for very large commercial air conditioning and refrigerant systems.

### Features

- Full flow fittings for low pressure drop
- Corrosion resistant epoxy powder paint finish
- Sturdy steel shells for long life durability

### Specifications

Filtration (with core).....	40 microns
Maximum working pressure .....	500 psig* (35 bar)
UL/CUL file number .....	SA 3124
Bolt torque.....	35 ft-lbs

\* Not suitable for R-410A applications above 500 psig.

### Model number nomenclature - Example: ADKS 30013T

Series	Unit size	Connection size	Access	Sequential identifier	Customer special	Pack type
ADKS	300	13	T			
Take-Apart Liquid and Suction Line Filters Driers	In Cubic In.	In 1/8" Increments	T = Tap Access Connection (Omit for no access valve)	Blank Thru -99	G = Customer Special (Omit for Standard)	B1 = Bulk Pack (Omit for Individual Pack)

### ADKS Liquid And Suction Line Filter Drier

Unit size (cubic inches)	Inlet x outlet connection size	Access type	Number of 100 in <sup>3</sup> cores	Flow capacity in tons @ 1 psi Δp 1, 2				Model number	Item number
				R-22 / R-410a / R-448a / R-449a	R-134a / R-450a / R-513a	R-404 / 507	R-407c		
300	1-5/8" X 1-5/8" ODF	Tap Access	3	110	102	73	108	ADKS 30013T	026570
300	2-1/8" X 2-1/8" ODF	Tap Access	3	160	148	107	157	ADKS 30017T	037978
400	2-1/8" X 2-1/8" ODF	Tap Access	4	170	157	114	167	ADKS 40017T	032105
400	2-5/8" X 2-5/8" ODF	Tap Access	4	180	166	120	177	ADKS 40021T	037570

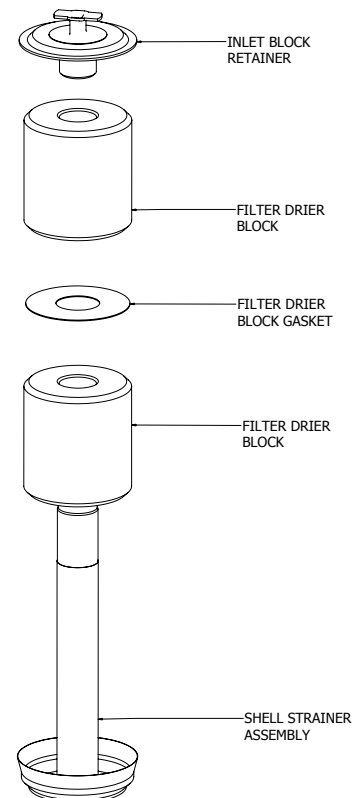
Models are shipped without filter cores or filter drier cores. Use 100 cubic inch cores.

### ADKS series replacement parts

Description	Model number	Item number
ADKS 300 cu. In. Shell Strainer Replacement Kit	X-10574-5	039967
ADKS 400 cu. In. Shell Strainer Replacement Kit	X-10574-6	038315
ADKS Series Replacement Flange and Plug Assembly	X-12176-3	054046



Capacity tables





H 48

# Filter Drier Cores and Filters for Take-Apart Shells

Universal replacement cores and filter cores for use in our ADKS and STAS shells and similar competitive Take-Apart type filter drier shells. May not be used for BTAS.

## Features

- Water capacities to suit specific system conditions
- Exceptional acid capacities for normal system protection, or to effectively clean-up following a compressor burnout
- Activated carbon blend for soluble contaminant and wax removal (W-HH Series)

**Model number nomenclature - Example: H 48**

Series	Unit size
H	48
Universal Replacement Cores and Filters	In Cubic In.

## Filter Drier Cores and Filters

Function	Description <sup>3</sup>	Water capacity <sup>1</sup> (drops of water <sup>2</sup> )																Model number <sup>3</sup>	Item number
		R-22		R-134A		R-404A / R-507		R-407C		R-410A		R-448A / R-449A		R-450A / R-513A		R-744			
		75°F	125°F	75°F	125°F	75°F	125°F	75°F	125°F	75°F	125°F	75°F	125°F	75°F	125°F	14°F	75°F		
High Acid and Water Removal Premium Universal Replacement	Premium Universal Replacement Filter Drier Core for ADKS Shells and Similar Competitive Take-Apart Filter Drier Shells	2574	2345	2769	2550	2868	2710	2182	1682	1616	1303	1683	1531	2787	2437	1887	2073	UK 100	062424
High Acid and Water Removal Premium Universal Replacement	Premium Universal Replacement Filter Drier Core for STAS Shells and Similar Competitive Take-Apart Filter Drier Shells	1181	1072	1272	1168	1319	1241	1033	786	976	707	942	857	1332	1150	1184	1388	UK 48	061617
High Acid and Water Removal	Filter Drier Core for High Acid and Water Removal in ADKS Shells and Similar Competitive Take-Apart Filter Drier Shells	962	673	1112	834	1199	839	726	418	672	364	238	219	1109	758	526	550	H 100	089338
High Acid and Water Removal	Block Filter Drier Core for High Acid and Water Removal in STAS Shells and Similar Competitive Take-Apart Filter Drier Shells	597	436	676	538	721	535	445	285	380	226	388	225	643	475	274	321	H 48	059542
High Acid Removal	Block Filter Drier Core for High Acid Removal in STAS not for BTAS	363	254	415	340	457	343	225	95	210	86	106	98	388	225	186	218	D 48	059541
Highest Water Removal	Filter Drier Core for Highest Water Removal in STAS Shells and Similar Competitive Take-Apart Filter Drier Shells	1600	1491	1710	1600	1765	1710	1459	1161	1280	930	1050	974	1932	1744	929	1027	HX 48	062549
Refrigerant Reclaim / Maximum Moisture Removal	Filter Drier Core / Filter for CFC, HCFC Refrigerant Reclamation and Maximum Moisture Removal	1037	790	1096	920	1090	940	750	530	650	420	421	384	643	475	576	621	RH 48	061237
Refrigerant Reclaim / Burnout with Wax Removal	Universal Replacement Cores for STAS Shells and Similar Competitive Take-Apart Filter Drier Shells	532	380	583	493	600	482	380	230	350	197	147	135	444	306	294	308	RW 48	061238

*Filter Drier Cores and Filters (continued)*

Function	Description <sup>3</sup>	Water capacity <sup>1</sup> (drops of water <sup>2</sup> )																Model number <sup>3</sup>	Item number
		R-22		R-134A		R-404A / R-507		R-407C		R-410A		R-448A / R-449A		R-450A / R-513A		R-744			
		75°F	125°F	75°F	125°F	75°F	125°F	75°F	125°F	75°F	125°F	75°F	125°F	75°F	125°F	14°F	75°F		
Burnout Cleanup with Charcoal	Burnout Clean Up Filter Drier Core for ADKS Shells and Similar Competitive Take-Apart Filter Drier Shells	938	621	1077	812	1162	792	629	363	573	307	248	228	960	663	510	534	W 100HH	043582
Burnout Cleanup with Charcoal	Burnout Clean Up Filter Drier Core for STAS Shells and Similar Competitive Take-Apart Filter Drier Shells	335	226	387	294	417	289	290	165	249	130	119	109	444	306	328	386	W 48HH	061235
Solid Contaminant Filter (Suction Only)	Replacement Filter (Suction Only) for STAS Not for BTAS	—	—	—	—	—	—	—	—	—	—	—	—	—	—	—	—	F 48	089559
Solid Contaminant Filter (Suction Only) Reverse Flow	Replacement Filter (Suction Only) Reverse Flow for STAS and Similar Competitive Filters Not for BTAS	—	—	—	—	—	—	—	—	—	—	—	—	—	—	—	—	F 48R	047664
Solid Contaminant Filter (Suction Only)	Replacement Filter (Suction Only) for ADKS and Similar Competitive Filters Not for BTAS	—	—	—	—	—	—	—	—	—	—	—	—	—	—	—	—	F 100	095762

<sup>1</sup> Water Capacities are based on:  
50 parts per million for R-134a, R404-A/R-410A  
and R-407C 60 parts per million for R-22  
15 parts per million for R-12

<sup>2</sup> 20 drops of water = 1 gram = 1 cc  
Equilibrium Point Dryness (EPD) of:

<sup>3</sup> D-42 and H-42 include one neoprene composite lid gasket and one core gasket. All other cores include a universal neoprene composite gasket kit which includes 2 sizes of replacement lid gaskets, and gaskets for the top and bottom of the core or filter.



**BTAS 311SV**

## BTAS Series Take-Apart Suction Line Filter Driers

The BTAS is a replaceable core take-apart filter drier for suction line service ideal for commercial refrigeration applications.

### Features

- Full flow fittings for low pressure drop
- Corrosion resistant brass body with stainless steel bolts
- Special cartridge design exclusive to brass shell

### Specifications

Filtration ..... 40 microns with core  
 Maximum working pressure ..... 400 psig (28 bar)  
 UL/CUL file number ..... SA3124  
 Canadian CRN ..... 0E21971.513467890YTN

#### Model number nomenclature - Example: BTAS 311SV

Series	Unit size	Connection size	Type	Sequential identifier	Customer special	Pack type
BTAS	3	11	SV			
Brass Take-Apart Suction Line Filter Driers	Nominal Shell Diameter In Inches	In 1/8" Increments	SV = Suction Line Service	S = ODF (Omit for SAE)	Blank Thru -99	G = Customer Special (Omit for Standard)

#### BTAS Series Take-Apart Filter Driers and Cores

Unit size (diameter in inches)	Inlet x outlet connection size	Model number	Item number
2	7/8" X 7/8" ODF	BTAS 27SV	049462
3	1-1/8" X 1-1/8" ODF	BTAS 39SV	049465
3	1-3/8" X 1-3/8" ODF	BTAS 311SV	049466
3	1-5/8" X 1-5/8" ODF	BTAS 313SV	049467
3	2-1/8" X 2-1/8" ODF	BTAS 317SV	049468
4	1-3/8" X 1-3/8" ODF	BTAS 411SV	064169
4	1-5/8" X 1-5/8" ODF	BTAS 413SV	049470
4	2-1/8" X 2-1/8" ODF	BTAS 417SV	049471
4	2-5/8" X 2-5/8" ODF	BTAS 421SV	049472
5	2-1/8" X 2-1/8" ODF	BTAS 517SV	049473
5	2-5/8" X 2-5/8" ODF	BTAS 521SV	049474
5	3-1/8" X 3-1/8" ODF	BTAS 525SV	049475

BTAS models are shipped without filter cartridge or Filter Drier cartridge.

*Type A-F replaceable filter cartridges*

For shell no.	Core O.D.	Core length	Filter area (square in.)	Weight (lbs)	Model number	Item number
BTAS 2	1 29/32	6 3/8	66	0.33	A2 F	049479
BTAS 3	2 3/4	6 7/8	115	0.50	A3 F	049480
BTAS 4	3 3/4	7 1/2	189	0.88	A4 F	049481
BTAS 5	4 5/16	8 1/2	270	1.00	A5 F	049482

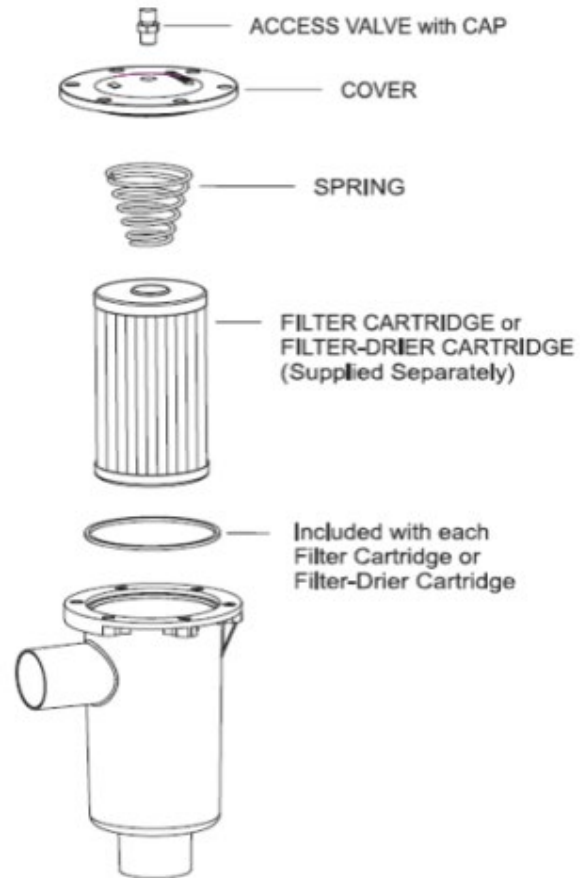
*Type A-F-D replaceable filter drier cartridges*

For shell no.	Cartridge O.D.	Cartridge length	Desiccant volume (cubic in.)	Weight (lbs)	Model number	Item number
BTAS 2	1 29/32	6 3/8	4.2	0.50	A2 FD	049483
BTAS 3	2 3/4	6 7/8	13.3	0.88	A3 FD	049484
BTAS 4	3 3/4	7 1/2	26.0	1.20	A4 FD	049485
BTAS 5	4 5/16	8 1/2	36.5	1.20	A5 FD	049486

*BTAS series replacement parts\**

Description	Model number	Item number
Access Valve	X-11562-2	037409
BTAS 2 Repair Kit*	KD-30519-2	065970
BTAS 3 Repair Kit*	KD-30519-3	065971
BTAS 4 Repair Kit*	KD-30519-4	065972
BTAS 5 Repair Kit*	KD-30519-5	065973
BTAS 2 Seal Ring Kit	KD-40015-1	066430
BTAS 3 Seal Ring Kit	KD-40015-2	066431
BTAS 4 Seal Ring Kit	KD-40015-3	066432
BTAS 5 Seal Ring Kit	KD-40015-4	066433

\* Repair kits contain cover bolts, cover, spring and seal ring.



Capacity tables



ASD 35S5VV

# ASD Series Premium Hermetic Suction Line Filter Driers

The ASD is a premium beaded suction line filter drier optimized for high moisture, acid, and solid contaminant removal.

## Features

- Outstanding filtration for ultimate compressor protection
- Dual access valves for easy pressure readings
- Solid copper connections
- Corrosion resistant epoxy powder paint finish

## Specifications

Filtration ..... 40 microns  
 Maximum working pressure ..... 500 psig (35 bar)  
 UL/CUL file number ..... SA3124  
 Canadian CRN ..... OE21971.513467890YTN

### Model number nomenclature - Example: ASD 35S5VV

Series	Unit size	Connection style	Connection size	Access	Sequential identifier	Customer special	Pack type
ASD	35	S	5	VV			
Premium Hermetic Suction Line Filter Driers	In Cubic In.	S = ODF F = SAE	In 1/8" Increments	VV = Dual Access Valves	Blank Thru -99	G = Customer Special (Omit for Standard)	B1 = Bulk Pack (Omit for Individual Pack)

### ASD Series Suction Line Filter Drier

Unit size (cubic inches)	Inlet x outlet connection size	Access	Model number	Item number
28	3/8" X 3/8" ODF	Dual	ASD 28S3VV	049168
28	3/8" X 3/8" SAE	None	ASD 28F3	056352
28	1/2" X 1/2" ODF	Dual	ASD 28S4VV	049169
35	5/8" X 5/8" SAE	Dual	ASD 35F5VV	049170
35	5/8" X 5/8" ODF	Dual	ASD 35S5VV	049171
45	3/4" X 3/4" ODF	Dual	ASD 45S6VV	049172
45	7/8" X 7/8" ODF	Dual	ASD 45S7VV	049173
50	1-1/8" X 1-1/8" ODF	Dual	ASD 50S9VV	049174
75	1-3/8" X 1-3/8" ODF	Dual	ASD 75S11VV	049175
75	1-5/8" X 1-5/8" ODF	Dual	ASD 75S13VV	049176



Capacity tables



SFD 13S5VV

# SFD Series Hermetic Suction Line Filter Driers

The SFD is a standard suction line beaded filter drier for use air conditioning, heat pump and refrigeration applications.

## Features

- Solid copper connections
- Dual access valves for easy pressure readings
- Corrosion resistant epoxy powder paint finish

## Specifications

Filtration .....40 microns  
 Maximum working pressure .....500 psig (35 bar)  
 UL/CUL file number .....SA3124  
 Canadian CRN .....0E21971.513467890YTN

Model number nomenclature - Example: SFD 13S5VV

Series	Unit size	Connection style	Connection size	Access type	Sequential identifier	Customer special	Pack type
SFD	13	S	5	VV			
Steel Take-Apart Series	In Cubic In.	S = ODF F = SAE	In 1/8" Increments	VV = Dual Access Valves	Blank Thru -99	G = Customer Special (Omit for Standard)	B1 = Bulk Pack (Omit for Individual Pack)

## SFD Series Hermetic Suction Line Filter Driers

Unit size (cubic inches)	Inlet x outlet connection size	Access type	Model number	Item number
8	1/2" X 1/2" ODF	Dual	SFD 08S4VV	064045
8	5/8" X 5/8" ODF	Dual	SFD 08S5VV	064046
8	3/4" X 3/4" ODF	Dual	SFD 08S6VV	064047
13	3/8" X 3/8" ODF	Dual	SFD 13S3VV	060245
13	3/8" X 3/8" SAE	Dual	SFD 13F3VV	060244
13	1/2" X 1/2" ODF	Dual	SFD 13S4VV	060247
13	1/2" X 1/2" SAE	Dual	SFD 13F4VV	060246
13	5/8" X 5/8" ODF	Dual	SFD 13S5VV	060249
13	5/8" X 5/8" SAE	Dual	SFD 13F5VV	060248
13	3/4" X 3/4" ODF	Dual	SFD 13S6VV	060250
13	7/8" X 7/8" ODF	Dual	SFD 13S7VV	060262
27	3/4" X 3/4" ODF	Dual	SFD 27S6VV	056505
27	7/8" X 7/8" ODF	Dual	SFD 27S7VV	060251
27	1-1/8" X 1-1/8" ODF	Dual	SFD 27S9VV	060252
54	1-3/8" X 1-3/8" ODF	Dual	SFD 54S11VV	060253
54	1-5/8" X 1-5/8" ODF	Dual	SFD 54S13VV	060254



Capacity  
tables



CSFD 14S7VV

# CSFD Series Hermetic Compact Suction Line Filter Driers

The CSFD is a hermetic suction line filter drier used for moisture, acid and solid contaminant removal.

## Features

- Dual access valves for easy pressure readings
- High acid removal capacity
- Solid copper fittings for easy brazing
- Corrosion resistant epoxy powder paint finish

## Specifications

Filtration ..... 40 microns  
 Maximum working pressure ..... 500 psig (35 bar)  
 UL/CUL file number ..... SA3124  
 Canadian CRN ..... OE21971.513467890YTN

Model number nomenclature - Example: CSFD 14S4VV

Series	Unit size	Connection style	Connection size	Access	Sequential identifier	Customer special	Pack type
CSFD	14	S	4	VV			
Hermetic Suction Line Filter Driers	In Cubic In.	S = ODF	In 1/8" Increments	VV = Dual Access Valve	Blank Thru -99	G = Customer Special (Omit for Standard)	B1 = Bulk Pack (Omit for Individual Pack)

### CSFD Compact Series Suction Line Filter Driers

Unit size (cubic inches)	Inlet x outlet connection size	Access type	Model number	Item number
14	1/2" X 1/2" ODF	Dual	CSFD 14S4VV	062231
14	5/8" X 5/8" ODF	Dual	CSFD 14S5VV	062232
14	3/4" X 3/4" ODF	Dual	CSFD 14S6VV	062233
14	7/8" X 7/8" ODF	Dual	CSFD 14S7VV	062234
14	1-1/8" X 1-1/8" ODF	Dual	CSFD 14S9VV	062235



Capacity  
tables



ASK 306SVVHH

# ASK Series Hermetic Suction Line Filter Driers

The ASK is a refrigerant filter drier that utilizes a solid core with an activated carbon blend to maximize acid, moisture and wax removal.

## Features

- Dual access valves for easy pressure readings
- Corrosion resistant epoxy powder paint finish
- Activated carbon blend for soluble contaminant and wax
- Solid copper connections

## Specifications

Filtration .....40 microns  
 Maximum Working Pressure.....500 psig (35 bar)  
 UL/CUL File Number.....SA3124  
 Canadian CRN.....OE21971.513467890YTN

Model number nomenclature - Example: ASK 306SVVHH

Series	Unit size	Connection size	Connection style	Access	Desiccant type	Sequential identifier	Customer special	Pack type
ASK	30	6	S	VV	HH			
Hermetic Suction Line Filter Driers	In Cubic In.	In 1/8" Increments	S = ODF	VV = Dual Access Valves	HH = Activated Carbon	Blank Thru -99	G = Customer Special (Omit for Standard)	B1 = Bulk Pack (Omit for Individual Pack)

### ASK Series Suction Line Filter Drier

Unit size (cubic inches)	Inlet x outlet connection size	Access	Model number	Item number
16	5/8" X 5/8" ODF	Dual	ASK 165SVVHH	056508
16	3/4" X 3/4" ODF	Dual	ASK 166SVVHH	056509
16	7/8" X 7/8" ODF	Dual	ASK 167SVVHH	056510
30	3/4" X 3/4" ODF	Dual	ASK 306SVVHH	056511
30	7/8" X 7/8" ODF	Dual	ASK 307SVVHH	056512
30	1-1/8" X 1-1/8" ODF	Dual	ASK 309SVVHH	056513



Capacity tables



ASF 45S6VV

# ASF Series Hermetic Suction Line Filters

The ASF is a refrigerant filter drier designed to protect the compressor from dirt and all solid contaminants.

## Features

- Dual access valves for easy pressure readings
- Solid copper connections
- Corrosion resistant epoxy powder paint finish

## Specifications

Filtration .....40 microns  
 Maximum working pressure .....500 psig (35 bar)  
 UL/CUL file number.....SA3124  
 Canadian CRN.....OE21971.513467890YTN

Model number nomenclature - Example: ASF 35S5VV

Series	Unit size	Connection style	Connection size	Access	Sequential identifier	Customer special	Pack type
ASF	35	S	5	VV			
Hermetic Suction Line Filter Driers	In Cubic In.	S = ODF F = SAE	In 1/8" Increments	VV = Dual Access Valves	Blank Thru -99	G = Customer Special (Omit for Standard)	B1 = Bulk Pack (Omit for Individual Pack)

## ASF Series Suction Line Filters

Unit size (cubic inches)	Inlet x outlet connection size	Access type	Model number	Item number
11	1/2" X 1/2" ODF	None	ASF 11S4	062961
11	5/8" X 5/8" ODF	None	ASF 11S5	062962
28	3/8" X 3/8" ODF	Dual	ASF 28S3VV	049177
28	1/2" X 1/2" ODF	Dual	ASF 28S4VV	049178
28	7/8" X 7/8" ODF	Dual	ASF 28S7VV	062963
28	1-1/8" X 1-1/8" ODF	Dual	ASF 28S9VV	062964
35	5/8" X 5/8" ODF	Dual	ASF 35S5VV	049180
35	5/8" X 5/8" SAE	Dual	ASF 35F5VV	049179
45	3/8" X 3/8" SAE	Dual	ASF 45F3VV	059999
45	3/4" X 3/4" ODF	Dual	ASF 45S6VV	049181
45	7/8" X 7/8" ODF	Dual	ASF 45S7VV	049182
50	1-1/8" X 1-1/8" ODF	Dual	ASF 50S9VV	049183
64	2-1/8" X 2-1/8" ODF	Single	ASF 64S17V	063113
64	2-5/8" X 2-5/8" ODF	Single	ASF 64S21V	063115
75	1-3/8" X 1-3/8" ODF	Dual	ASF 75S11VV	049184
75	1-5/8" X 1-5/8" ODF	Dual	ASF 75S13VV	049185



Capacity  
tables

# HERMETIC SUCTION LINE FILTER DRIER FLOW CAPACITIES

Model number	Connections (in)	Flow capacity in tons refrigerant <sup>1</sup> (for kw, multiply tons by 3.5) <sup>2</sup>											
		R-12				R-134A / R-450A / R-513A				R-744			
		Evaporator temperature (°f)											
		40	20	0	-20	40	20	0	-20	20	0	-20	-40
		Pressure drop (psi)											
		2.0	1.5	1.0	0.5	2.0	1.5	1.0	0.5	6.0	5.0	4.0	3.0
ASD 28S3VV	3/8 ODF	1.1	0.6	0.5	0.5	1.1	0.6	0.5	0.4	7.2	6.3	6.8	8.5
ASD 28S4VV	1/2 ODF	1.8	1.2	0.8	0.7	1.9	1.2	0.8	0.6	11.8	10.2	10.6	14.2
ASD 35F5VV	5/8 SAE	2.1	1.4	1.1	0.9	2.2	1.4	1.0	0.8	13.7	12.2	12.9	17.0
ASD 35S5VV	5/8 ODF	2.8	1.9	1.4	1.1	2.9	1.9	1.3	1.0	18.1	15.6	16.7	22.7
ASD 45S6VV	3/4 ODF	3.8	2.5	1.8	1.2	3.9	2.5	1.7	1.1	21.8	22.4	24.2	28.4
ASD 45S7VV	7/8 ODF	5.0	3.6	2.3	1.5	5.1	3.5	2.2	1.3	28.7	29.2	31.1	36.9
ASD 50S9VV	1-1/8 ODF	7.1	5.0	3.2	1.8	7.3	4.9	3.0	1.6	41.1	41.3	43.2	49.6
ASD 75S11VV	1-3/8 ODF	8.6	5.9	3.7	2.0	8.8	5.8	3.5	1.8	50.5	49.6	50.8	56.7
ASD 75S13VV	1-5/8 ODF	9.0	6.2	3.9	2.1	9.3	6.1	3.7	1.9	53.9	52.0	53.0	59.6
ASF 28S3VV	3/8 ODF	1.2	0.8	0.5	0.5	1.2	0.8	0.5	0.4	7.5	6.3	6.8	9.9
ASF 28S4VV	1/2 ODF	1.9	1.3	0.9	0.8	2.0	1.3	0.9	0.7	12.8	11.2	12.1	17.0
ASF 35F5VV	5/8 SAE	2.2	1.5	1.1	0.9	2.3	1.5	1.0	0.8	14.6	12.6	13.6	18.4
ASF 35S5VV	5/8 ODF	3.2	2.2	1.6	1.4	3.3	2.2	1.5	1.2	20.6	18.0	19.7	26.9
ASF 45S6VV	3/4 ODF	4.7	3.2	2.3	1.8	4.8	3.1	2.2	1.6	30.5	26.7	28.0	38.3
ASF 45S7VV	7/8 ODF	6.5	4.8	3.3	1.9	6.7	4.7	3.1	1.7	37.4	38.9	42.4	51.0
ASF 50S9VV	1-1/8 ODF	9.2	6.8	4.5	2.6	9.5	6.7	4.3	2.3	59.2	58.3	62.1	69.5
ASF 64S17VV	2-1/8 ODF	25.3	18.3	12.6	7.2	26.0	18.0	12.0	6.4	127.8	131.2	144.0	170.2
ASF 75S11VV	1-3/8 ODF	11.7	8.8	5.9	3.4	12.0	8.7	5.6	3.0	49.9	72.9	83.4	95.0
ASF 75S13VV	1-5/8 ODF	13.6	9.7	6.6	3.8	14.0	9.5	6.3	3.4	74.8	72.9	75.8	92.2
ASK 165S-VVHH	5/8 ODF	1.9	1.4	0.8	0.6	2.0	1.4	0.8	0.5	10.6	10.2	10.6	12.8
ASK 166SVVHH	3/4 ODF	2.4	1.7	1.1	0.7	2.5	1.7	1.0	0.6	13.1	12.6	12.9	14.2
ASK 167SVVHH	7/8 ODF	2.6	1.8	1.2	0.7	2.7	1.8	1.1	0.6	14.3	13.6	14.4	15.6
ASK 306SVVHH	3/4 ODF	3.3	2.3	1.5	0.9	3.4	2.3	1.4	0.8	17.1	17.0	17.4	19.9
ASK 307SVVHH	7/8 ODF	3.5	2.5	1.6	0.9	3.6	2.5	1.5	0.8	19.0	18.5	18.9	21.3
ASK 309SVVHH	1-1/8 ODF	3.8	2.6	1.7	0.9	3.9	2.6	1.6	0.8	20.3	19.4	19.7	22.7
CSFD 14S4VV	1/2 ODF	1.3	0.9	0.5	0.3	1.3	0.9	0.5	0.3	6.2	6.3	6.8	8.5
CSFD 14S5VV	5/8 ODF	2.2	1.5	0.9	0.6	2.3	1.5	0.9	0.5	11.2	11.7	12.1	14.2
CSFD 14S6VV	3/4 ODF	3.0	2.1	1.3	0.8	3.1	2.1	1.3	0.7	15.3	15.6	16.7	19.9
CSFD 14S7VV	7/8 ODF	3.2	2.2	1.5	0.8	3.3	2.2	1.4	0.7	16.2	16.5	17.4	21.3
CSFD 14S9VV	1-1/8 ODF	4.4	3.1	1.9	1.1	4.5	3.0	1.8	1.0	21.8	22.4	23.5	28.4
SFD 13F3VV	3/8 SAE	0.7	0.4	0.2	0.1	0.7	0.4	0.2	0.1	4.4	3.9	3.0	2.8
SFD 13S3VV	3/8 ODF	1.3	0.8	0.5	0.2	1.3	0.8	0.5	0.2	6.9	6.3	6.1	7.1
SFD 13F4VV	1/2 SAE	1.5	1.0	0.6	0.3	1.5	1.0	0.6	0.3	7.5	7.8	8.3	9.9
SFD 13S4VV	1/2 ODF	2.2	1.5	1.1	0.6	2.3	1.5	1.0	0.5	10.9	11.2	12.1	14.2
SFD 13F5VV	5/8 SAE	2.4	1.7	1.2	0.7	2.5	1.7	1.1	0.6	11.5	11.7	12.1	14.2
SFD 13S5VV	5/8 ODF	3.0	2.1	1.4	0.8	3.1	2.1	1.3	0.7	15.3	15.6	16.7	19.9
SFD 13S6VV	3/4 ODF	4.0	2.7	1.8	1.0	4.1	2.7	1.7	0.9	19.9	20.4	21.2	25.5
SFD 13S7VV	7/8 ODF	4.3	3.1	2.0	1.1	4.4	3.0	1.9	1.0	22.4	22.4	22.7	26.9
SFD 27S6VV	3/4 ODF	4.0	2.7	1.8	1.0	4.1	2.7	1.7	0.9	19.9	20.4	21.2	25.5
SFD 27S7VV	7/8 ODF	4.6	3.2	2.0	1.1	4.7	3.1	1.9	1.0	23.4	23.3	24.2	28.4
SFD 27S9VV	1-1/8 ODF	5.1	3.5	2.1	1.1	5.2	3.4	2.0	1.0	26.5	26.2	26.5	29.8
SFD 54S11VV	1-3/8 ODF	4.4	2.9	1.8	1.0	4.5	2.9	1.7	0.9	22.8	22.4	22.7	25.5
SFD 54S13VV	1-5/8 ODF	4.5	3.1	1.9	1.0	4.6	3.0	1.8	0.9	23.1	22.8	24.2	28.4

<sup>1</sup> All ratings in accordance with ARI Standard 730-04.

<sup>2</sup> Example: 1.0 tons x 3.5 = 3.5 kW

# HERMETIC SUCTION LINE FILTER DRIER FLOW CAPACITIES

Model number	Connections (in)	Flow capacity in tons refrigerant <sup>1</sup> (for kw, multiply tons by 3.5) <sup>2</sup>														
		R-22 / R-448A / R-449A					R-407C					R-410A				
		Evaporator temperature (°F)														
		40	20	0	-20	-40	40	20	0	-20	-40	40	20	0	-20	-40
		Pressure drop (psi)														
3.0	2.0	1.5	1.0	0.5	3.0	2.0	1.5	1.0	0.5	3.0	2.0	1.5	1.0	0.5		
ASD 28S3VV	3/8 ODF	2.3	1.3	0.9	0.6	0.5	2.1	1.2	0.8	0.5	0.4	2.8	1.6	1.1	0.7	0.6
ASD 28S4VV	1/2 ODF	3.8	2.1	1.4	1.0	0.8	3.5	1.9	1.2	0.9	0.7	4.6	2.6	1.7	1.2	1.0
ASD 35F5VV	5/8 SAE	4.4	2.5	1.7	1.2	0.9	4.1	2.3	1.5	1.0	0.7	5.3	3.0	2.1	1.5	1.1
ASD 35S5VV	5/8 ODF	5.8	3.2	2.2	1.6	1.0	5.4	2.9	1.9	1.4	0.8	7.0	3.9	2.7	2.0	1.3
ASD 45S6VV	3/4 ODF	7.0	4.6	3.2	2.0	1.1	6.5	4.2	2.8	1.7	0.9	8.5	5.6	3.9	2.5	1.4
ASD 45S7VV	7/8 ODF	9.2	6.0	4.1	2.6	1.4	8.5	5.5	3.6	2.3	1.2	11.2	7.3	5.0	3.2	1.8
ASD 50S9VV	1-1/8 ODF	13.2	8.5	5.7	3.5	1.8	12.2	7.7	5.0	3.1	1.5	16.0	10.3	7.0	4.3	2.3
ASD 75S11VV	1-3/8 ODF	16.2	10.2	6.7	4.0	2.0	15.0	9.3	5.9	3.5	1.7	19.6	12.4	8.2	5.0	2.5
ASD 75S13VV	1-5/8 ODF	17.3	10.7	7.0	4.2	2.1	16.0	9.7	6.2	3.7	1.7	21.0	13.0	8.6	5.2	2.6
ASF 28S3VV	3/8 ODF	2.4	1.3	0.9	0.7	0.5	2.2	1.2	0.8	0.6	0.4	2.9	1.6	1.1	0.9	0.6
ASF 28S4VV	1/2 ODF	4.1	2.3	1.6	1.2	0.9	3.8	2.1	1.4	1.0	0.7	5.0	2.8	2.0	1.5	1.1
ASF 35F5VV	5/8 SAE	4.7	2.6	1.8	1.3	1.0	4.4	2.4	1.6	1.1	0.8	5.7	3.2	2.2	1.6	1.3
ASF 35S5VV	5/8 ODF	6.6	3.7	2.6	1.9	1.6	6.1	3.4	2.3	1.7	1.3	8.0	4.5	3.2	2.4	2.0
ASF 45S6VV	3/4 ODF	9.8	5.5	3.7	2.7	2.2	9.1	5.0	3.3	2.4	1.8	11.9	6.7	4.5	3.4	2.8
ASF 45S7VV	7/8 ODF	12.0	8.0	5.6	3.6	3.0	11.1	7.3	5.0	3.1	2.5	14.6	9.7	6.9	4.5	3.8
ASF 50S9VV	1-1/8 ODF	19.0	12.0	8.2	4.9	2.6	17.6	10.9	7.3	4.3	2.2	23.0	14.6	10.1	6.1	3.3
ASF 64S17VV	2-1/8 ODF	41.0	27.0	19.0	12.0	6.9	38.0	24.5	16.8	10.5	5.7	49.7	32.8	23.3	14.9	8.6
ASF 75S11VV	1-3/8 ODF	16.0	15.0	11.0	6.7	3.3	14.8	13.6	9.7	5.8	2.7	19.4	18.2	13.5	8.3	4.1
ASF 75S13VV	1-5/8 ODF	24.0	15.0	10.0	6.5	3.2	22.2	13.6	8.9	5.7	2.7	29.1	18.2	12.3	8.1	4.0
ASK 165S-VVHH	5/8 ODF	3.4	2.1	1.4	0.9	0.4	3.2	1.9	1.2	0.8	0.3	4.1	2.6	1.7	1.1	0.5
ASK 166S-VVHH	3/4 ODF	4.2	2.6	1.7	1.0	0.5	3.9	2.4	1.5	0.9	0.4	5.1	3.2	2.1	1.2	0.6
ASK 167S-VVHH	7/8 ODF	4.6	2.8	1.9	1.1	0.6	4.3	2.5	1.7	1.0	0.5	5.6	3.4	2.3	1.4	0.8
ASK 306S-VVHH	3/4 ODF	5.5	3.5	2.3	1.4	0.8	5.1	3.2	2.0	1.2	0.7	6.7	4.3	2.8	1.7	1.0
ASK 307S-VVHH	7/8 ODF	6.1	3.8	2.5	1.5	0.8	5.7	3.5	2.2	1.3	0.7	7.4	4.6	3.1	1.9	1.0
ASK 309S-VVHH	1-1/8 ODF	6.5	4.0	2.6	1.6	0.8	6.0	3.6	2.3	1.4	0.7	7.9	4.9	3.2	2.0	1.0
CSFD 14S4VV	1/2 ODF	2.0	1.3	0.9	0.6	0.3	1.9	1.2	0.8	0.5	0.2	2.4	1.6	1.1	0.7	0.4
CSFD 14S5VV	5/8 ODF	3.6	2.4	1.6	1.0	0.5	3.3	2.2	1.4	0.9	0.4	4.4	2.9	2.0	1.2	0.6
CSFD 14S6VV	3/4 ODF	4.9	3.2	2.2	1.4	0.7	4.5	2.9	1.9	1.2	0.6	5.9	3.9	2.7	1.7	0.9
CSFD 14S7VV	7/8 ODF	5.2	3.4	2.3	1.5	0.8	4.8	3.1	2.0	1.3	0.7	6.3	4.1	2.8	1.9	1.0
CSFD 14S9VV	1-1/8 ODF	7.0	4.6	3.1	2.0	1.0	6.5	4.2	2.7	1.7	0.8	8.5	5.6	3.8	2.5	1.3
SFD 13F3VV	3/8 SAE	1.4	0.8	0.4	0.2	0.1	1.3	0.7	0.4	0.2	0.1	1.7	1.0	0.5	0.2	0.1
SFD 13S3VV	3/8 ODF	2.2	1.3	0.8	0.5	0.2	2.0	1.2	0.7	0.4	0.2	2.7	1.6	1.0	0.6	0.3
SFD 13F4VV	1/2 SAE	2.4	1.6	1.1	0.7	0.4	2.2	1.5	1.0	0.6	0.3	2.9	1.9	1.3	0.9	0.5
SFD 13S4VV	1/2 ODF	3.5	2.3	1.6	1.0	0.6	3.2	2.1	1.4	0.9	0.5	4.2	2.8	2.0	1.2	0.8
SFD 13F5VV	5/8 SAE	3.7	2.4	1.6	1.0	0.6	3.4	2.2	1.4	0.9	0.5	4.5	2.9	2.0	1.2	0.8
SFD 13S5VV	5/8 ODF	4.9	3.2	2.2	1.4	0.8	4.5	2.9	1.9	1.2	0.7	5.9	3.9	2.7	1.7	1.0
SFD 13S6VV	3/4 ODF	6.4	4.2	2.8	1.8	1.0	5.9	3.8	2.5	1.6	0.8	7.8	5.1	3.4	2.2	1.3
SFD 13S7VV	7/8 ODF	7.2	4.6	3.0	1.9	1.0	6.7	4.2	2.7	1.7	0.8	8.7	5.6	3.7	2.4	1.3
SFD 27S6VV	3/4 ODF	6.4	4.2	2.8	1.8	1.0	5.9	3.8	2.5	1.6	0.8	7.8	5.1	3.4	2.2	1.3
SFD 27S7VV	7/8 ODF	7.5	4.8	3.2	2.0	1.1	7.0	4.4	2.8	1.7	0.9	9.1	5.8	3.9	2.5	1.4
SFD 27S9VV	1-1/8 ODF	8.5	5.4	3.5	2.1	1.1	7.9	4.9	3.1	1.8	0.9	10.3	6.6	4.3	2.6	1.4
SFD 54S11VV	1-3/8 ODF	7.3	4.6	3.0	1.8	1.0	6.8	4.2	2.7	1.6	0.8	8.9	5.6	3.7	2.2	1.3
SFD 54S13VV	1-5/8 ODF	7.4	4.7	3.2	2.0	1.0	6.9	4.3	2.8	1.7	0.8	9.0	5.7	3.9	2.5	1.3

<sup>1</sup> All ratings in accordance with ARI Standard 730-04.

<sup>2</sup> Example: 1.0 tons x 3.5 = 3.5 kW

# HERMETIC SUCTION LINE FILTER DRIER FLOW CAPACITIES

Model number	Connections (in)	Flow capacity in tons refrigerant <sup>1</sup> (for kw, multiply tons by 3.5) <sup>2</sup>								
		R-502				R-404A / R-507				
		Evaporator temperature (°f)								
		40	20	0	-20	40	20	0	-20	-40
		Pressure drop (psi)								
		3.0	2.0	1.5	1.0	3.0	2.0	1.5	1.0	0.5
ASD 28S3VV	3/8 ODF	2.2	1.1	0.7	0.5	2.1	1.1	0.7	0.5	0.3
ASD 28S4VV	1/2 ODF	3.7	1.8	1.1	0.7	3.6	1.8	1.1	0.7	0.5
ASD 35F5VV	5/8 SAE	4.2	2.1	1.3	0.9	4.1	2.1	1.3	0.9	0.6
ASD 35S5VV	5/8 ODF	5.6	2.8	1.7	1.1	5.4	2.8	1.7	1.1	0.8
ASD 45S6VV	3/4 ODF	6.6	3.7	2.5	1.5	6.4	3.7	2.5	1.6	1.0
ASD 45S7VV	7/8 ODF	7.7	4.8	3.3	1.9	7.5	4.8	3.3	2.0	1.1
ASD 50S9VV	1-1/8 ODF	11.0	6.9	4.6	2.7	11.0	6.9	4.6	2.8	1.4
ASD 75S11VV	1-3/8 ODF	14.0	8.4	5.4	3.1	14.0	8.4	5.4	3.2	1.6
ASD 75S13VV	1-5/8 ODF	15.0	8.9	5.7	3.3	15.0	8.9	5.7	3.4	1.7
ASF 28S3VV	3/8 ODF	2.3	1.1	0.7	0.5	2.2	1.1	0.7	0.5	0.3
ASF 28S4VV	1/2 ODF	3.9	2.0	1.2	0.8	3.8	2.0	1.2	0.8	0.6
ASF 35F5VV	5/8 SAE	4.5	2.3	1.4	0.9	4.4	2.3	1.4	0.9	0.7
ASF 35S5VV	5/8 ODF	6.3	3.2	2.0	1.4	6.1	3.2	2.0	1.4	1.0
ASF 45S6VV	3/4 ODF	9.4	4.7	2.9	1.8	9.1	4.7	2.9	1.9	1.4
ASF 45S7VV	7/8 ODF	10.0	6.3	4.5	2.7	9.8	6.3	4.5	2.8	1.5
ASF 50S9VV	1-1/8 ODF	16.0	10.0	6.6	3.9	16.0	10.0	6.7	4.0	2.0
ASF 64S17VV	2-1/8 ODF	36.0	23.0	15.0	9.5	35.0	23.0	15.0	9.8	5.2
ASF 75S11VV	1-3/8 ODF	21.0	13.0	8.2	4.9	20.0	13.0	8.3	5.1	2.6
ASF 75S13VV	1-5/8 ODF	22.0	13.0	8.3	5.0	21.0	13.0	8.4	5.2	2.7
ASK 165S-VVHH	5/8 ODF	3.3	1.9	1.2	0.8	3.2	1.9	1.2	0.8	0.3
ASK 166S-VVHH	3/4 ODF	4.0	2.4	1.6	0.9	3.9	2.4	1.6	0.9	0.5
ASK 167S-VVHH	7/8 ODF	4.4	2.6	1.7	1.0	4.3	2.6	1.7	1.0	0.6
ASK 306S-VVHH	3/4 ODF	5.2	3.2	2.2	1.2	5.0	3.2	2.2	1.2	0.7
ASK 307S-VVHH	7/8 ODF	5.8	3.5	2.3	1.4	5.6	3.5	2.3	1.4	0.7
ASK 309S-VVHH	1-1/8 ODF	6.2	3.7	2.4	1.4	6.0	3.7	2.4	1.5	0.7
CSFD 14S4VV	1/2 ODF	1.3	0.8	0.5	0.3	1.3	0.8	0.5	0.3	0.2
CSFD 14S5VV	5/8 ODF	2.7	1.7	1.1	0.7	2.6	1.7	1.1	0.7	0.3
CSFD 14S6VV	3/4 ODF	3.7	2.3	1.5	0.9	3.6	2.3	1.5	0.9	0.5
CSFD 14S7VV	7/8 ODF	4.0	2.4	1.6	1.0	3.9	2.4	1.6	1.0	0.5
CSFD 14S9VV	1-1/8 ODF	5.1	3.1	2.0	1.3	4.9	3.1	2.0	1.3	0.7
SFD 13F3VV	3/8 SAE	1.3	0.7	0.4	0.2	1.3	0.7	0.4	0.2	0.1
SFD 13S3VV	3/8 ODF	2.0	1.1	0.7	0.4	1.9	1.1	0.7	0.4	0.2
SFD 13F4VV	1/2 SAE	2.2	1.3	0.9	0.5	2.1	1.3	0.9	0.5	0.3
SFD 13S4VV	1/2 ODF	3.1	1.9	1.3	0.8	3.0	1.9	1.3	0.8	0.4
SFD 13F5VV	5/8 SAE	3.3	2.0	1.4	0.9	3.2	2.0	1.4	0.9	0.5
SFD 13S5VV	5/8 ODF	4.3	2.7	1.8	1.1	4.2	2.7	1.8	1.1	0.6
SFD 13S6VV	3/4 ODF	5.8	3.5	2.3	1.4	5.6	3.5	2.3	1.4	0.7
SFD 13S7VV	7/8 ODF	6.5	3.9	2.6	1.4	6.3	3.9	2.6	1.5	0.8
SFD 27S6VV	3/4 ODF	5.8	3.5	2.3	1.4	5.6	3.5	2.3	1.4	0.7
SFD 27S7VV	7/8 ODF	6.7	4.1	2.7	1.5	6.5	4.1	2.7	1.6	0.8
SFD 27S9VV	1-1/8 ODF	7.7	4.6	3.0	1.6	7.5	4.6	3.0	1.7	0.9
SFD 54S11VV	1-3/8 ODF	6.6	3.9	2.5	1.4	6.4	3.9	2.5	1.5	0.7
SFD 54S13VV	1-5/8 ODF	6.7	4.0	2.6	1.5	6.5	4.0	2.6	1.6	0.8

<sup>1</sup> All ratings in accordance with ARI Standard 730-04.

<sup>2</sup> Example: 1.0 tons x 3.5 = 3.5 kW

# TAKE-APART SUCTION LINE FILTER DRIER FLOW CAPACITIES

Model number	Connections (in)	Filter drier cartridge	Flow capacity in tons refrigerant <sup>1</sup> (for kw, multiply tons by 3.5) <sup>2</sup>							
			R-12				R-134A / R-450A / R-513A			
			Evaporator temperature (°f)							
			40	20	0	-20	40	20	0	-20
			Pressure drop (psi)							
2	1.5	1	0.5	2	1.5	1	0.5			
ADKS 30013T	1-5/8 ODF	(3) F 100 Filter	24.0	17.0	12.0	7.0	25.0	17.0	11.0	6.2
ADKS 30017T	2-1/8 ODF	(3) F 100 Filter	42.0	31.0	20.0	12.0	43.0	30.0	19.0	11.0
ADKS 40017T	2-1/8 ODF	(4) F100 Filter	44.0	32.0	21.0	12.0	45.0	31.0	20.0	11.0
ADKS 40021T	2-5/8 ODF	(4) F100 Filter	66.0	48.0	32.0	19.0	68.0	47.0	30.0	17.0
ADKS 30013T	1-5/8 ODF	(3) 100 cu in Core	19.0	14.0	9.1	5.5	20.0	14.0	8.7	4.9
ADKS 30017T	2-1/8 ODF	(3) 100 cu in Core	30.0	22.0	15.0	8.7	31.0	22.0	14.0	7.7
ADKS 40017T	2-1/8 ODF	(4) 100 cu in Core	33.0	23.0	16.0	9.5	34.0	23.0	15.0	8.4
ADKS 40021T	2-5/8 ODF	(4) 100 cu in Core	48.0	35.0	23.0	14.0	49.0	34.0	22.0	12.0
BTAS 27SV	7/8 ODF	A2 F Filter	4.7	3.4	2.2	1.2	4.8	3.3	2.1	1.1
BTAS 39SV	1-1/8 ODF	A3 F Filter	7.1	5.1	3.4	1.9	7.3	5.0	3.2	1.7
BTAS 311SV	1-3/8 ODF	A3 F Filter	7.9	5.6	3.7	2.1	8.1	5.5	3.5	1.9
BTAS 313SV	1-5/8 ODF	A3 F Filter	13.0	8.9	5.9	3.4	13.0	8.8	5.6	3.0
BTAS 317SV	2-1/8 ODF	A3 F Filter	15.0	11.0	7.2	4.2	16.0	11.0	6.9	3.7
BTAS 411SV	1-3/8 ODF	A4 F Filter	17.0	12.0	8.0	4.5	17.0	12.0	7.4	4.0
BTAS 413SV	1-5/8 ODF	A4 F Filter	20.0	15.0	10.0	5.5	21.0	14.0	9.1	4.9
BTAS 417SV	2-1/8 ODF	A4 F Filter	28.0	20.0	13.0	7.5	29.0	20.0	12.0	6.7
BTAS 421SV	2-5/8 ODF	A4 F Filter	34.0	24.0	16.0	9.1	35.0	24.0	15.0	8.1
BTAS 517SV	2-1/8 ODF	A5 F Filter	33.0	24.0	16.0	9.1	34.0	24.0	15.0	8.1
BTAS 521SV	2-5/8 ODF	A5 F Filter	44.0	32.0	21.0	12.0	45.0	31.0	20.0	11.0
BTAS 525SV	3-1/8 ODF	A5 F Filter	54.0	39.0	25.0	15.0	56.0	38.0	24.0	13.0
BTAS 25SV	5/8 ODF	A2 FD Filter Drier	2.4	1.7	1.2	0.7	2.5	1.7	1.1	0.6
BTAS 27SV	7/8 ODF	A2 FD Filter Drier	4.0	2.8	1.9	1.1	4.1	2.8	1.8	1.0
BTAS 39SV	1-1/8 ODF	A3 FD Filter Drier	5.2	3.7	2.4	1.4	5.3	3.6	2.3	1.2
BTAS 311SV	1-3/8 ODF	A3 FD Filter Drier	7.2	5.2	3.4	1.9	7.4	5.1	3.2	1.7
BTAS 313SV	1-5/8 ODF	A3 FD Filter Drier	10.0	7.4	4.8	2.8	11.0	7.3	4.6	2.5
BTAS 317SV	2-1/8 ODF	A3 FD Filter Drier	12.0	8.5	5.7	3.3	12.0	8.4	5.4	2.9
BTAS 411SV	1-3/8 ODF	A4 FD Filter Drier	15.0	11.0	7.0	4.1	15.0	11.0	6.7	3.6
BTAS 413SV	1-5/8 ODF	A4 FD Filter Drier	17.0	12.0	7.2	4.2	16.0	12.0	6.9	3.7
BTAS 417SV	2-1/8 ODF	A4 FD Filter Drier	22.0	16.0	11.0	6.1	23.0	16.0	10.0	5.4
BTAS 421SV	2-5/8 ODF	A4 FD Filter Drier	23.0	17.0	12.0	6.3	24.0	17.0	11.0	5.6
BTAS 517SV	2-1/8 ODF	A5 FD Filter Drier	27.0	19.0	13.0	7.2	28.0	19.0	12.0	6.4
BTAS 521SV	2-5/8 ODF	A5 FD Filter Drier	32.0	23.0	15.0	8.8	33.0	23.0	14.0	7.8
BTAS 525SV	3-1/8 ODF	A5 FD Filter Drier	38.0	27.0	18.0	10.0	39.0	27.0	17.0	9.2
STAS 489SV	1-1/8 ODF	(1) F 48 Filter	13.0	8.0	5.0	2.0	13.0	8.0	5.0	2.0
STAS 4811SV	1-3/8 ODF	(1) F 48 Filter	15.0	10.0	6.0	3.0	15.0	10.0	6.0	3.0
STAS 4813SV	1-5/8 ODF	(1) F 48 Filter	19.0	12.0	7.0	5.0	20.0	12.0	7.0	4.0
STAS 4817SV	2-1/8 ODF	(1) F 48 Filter	24.0	15.0	11.0	6.0	25.0	15.0	10.0	5.0
STAS 4821SV	2-5/8 ODF	(1) F 48 Filter	29.0	20.0	14.0	7.0	30.0	20.0	13.0	6.0
STAS 9617SV	2-1/8 ODF	(2) F 48 Filter	27.0	18.0	11.0	6.0	28.0	18.0	10.0	5.0
STAS 9621SV	2-5/8 ODF	(2) F 48 Filter	37.0	25.0	16.0	8.0	38.0	25.0	15.0	7.0
STAS 9625SV	3-1/8 ODF	(2) F 48 Filter	44.0	30.0	19.0	10.0	45.0	30.0	18.0	8.0
STAS 489SV	1-1/8 ODF	(1) 48 cu in Core	8.0	6.0	4.0	1.0	8.0	6.0	4.0	1.0
STAS 4811SV	1-3/8 ODF	(1) 48 cu in Core	10.0	7.0	4.0	2.0	10.0	7.0	4.0	2.0
STAS 4813SV	1-5/8 ODF	(1) 48 cu in Core	13.0	8.0	5.0	3.0	13.0	8.0	5.0	3.0
STAS 4817SV	2-1/8 ODF	(1) 48 cu in Core	17.0	10.0	7.0	5.0	17.0	10.0	7.0	4.0
STAS 4821SV	2-5/8 ODF	(1) 48 cu in Core	19.0	13.0	8.0	6.0	20.0	13.0	8.0	5.0
STAS 9617SV	2-1/8 ODF	(2) 48 cu in Core	18.0	12.0	6.0	5.0	18.0	12.0	6.0	4.0
STAS 9621SV	2-5/8 ODF	(2) 48 cu in Core	24.0	17.0	11.0	6.0	25.0	17.0	10.0	5.0
STAS 9625SV	3-1/8 ODF	(2) 48 cu in Core	27.0	19.0	14.0	7.4	29.0	23.0	16.0	7.0

<sup>1</sup> All ratings in accordance with ARI Standard 730-04.

<sup>2</sup> Example: 1.0 tons x 3.5 = 3.5 kW

# TAKE-APART SUCTION LINE FILTER DRIER FLOW CAPACITIES

Model number	Connections (in)	Filter drier cartridge	Flow capacity in tons refrigerant <sup>1</sup> (for kw, multiply tons by 3.5) <sup>2</sup>														
			R-22 / R-448A / R-449A					R-407C					R-410A				
			Evaporator temperature (°f)														
			40	20	0	-20	-40	40	20	0	-20	-40	40	20	0	-20	-40
			Pressure drop (psi)														
3	2	1.5	1	0.5	3	2	1.5	1	0.5	3	2	1.5	1	0.5			
ADKS 30013T	1-5/8 ODF	(3) F-100 Filter	45.0	30.0	20.0	13.0	7.0	41.7	27.3	17.7	11.3	5.8	—	—	—	—	—
ADKS 30017T	2-1/8 ODF	(3) F-100 Filter	77.0	50.0	35.0	22.0	12.0	71.4	45.5	31.0	19.2	10.0	—	—	—	—	—
ADKS 40017T	2-1/8 ODF	(4) F-100 Filter	80.0	53.0	37.0	23.0	13.0	74.2	48.2	32.8	20.0	10.8	—	—	—	—	—
ADKS 40021T	2-5/8 ODF	(4) F-100 Filter	122.0	80.0	55.0	34.0	19.0	113.1	72.7	48.7	29.6	15.8	—	—	—	—	—
ADKS 30013T	1-5/8 ODF	(3) 100 cu in Core	35.0	23.0	16.0	10.0	5.5	32.4	20.9	14.2	8.7	4.6	—	—	—	—	—
ADKS 30017T	2-1/8 ODF	(3) 100 cu in Core	56.0	37.0	25.0	16.0	8.8	51.9	33.6	22.1	13.9	7.3	—	—	—	—	—
ADKS 40017T	2-1/8 ODF	(4) 100 cu in Core	61.0	40.0	27.0	17.0	9.5	56.5	36.4	23.9	14.8	7.9	—	—	—	—	—
ADKS 40021T	2-5/8 ODF	(4) 100 cu in Core	88.0	58.0	40.0	25.0	14.0	81.6	52.7	35.4	21.8	11.6	—	—	—	—	—
BTAS 27SV	7/8 ODF	A2F Filter	8.8	5.7	3.9	2.5	1.3	8.2	5.2	3.5	2.2	1.1	—	—	—	—	—
BTAS 39SV	1-1/8 ODF	A3F Filter	14.0	8.8	5.9	3.7	2.0	13.0	8.0	5.2	3.2	1.7	—	—	—	—	—
BTAS 311SV	1-3/8 ODF	A3F Filter	15.0	10.0	6.6	4.1	2.2	13.9	9.1	5.8	3.6	1.8	—	—	—	—	—
BTAS 313SV	1-5/8 ODF	A3F Filter	24.0	16.0	11.0	6.6	3.5	22.2	14.5	9.7	5.8	2.9	—	—	—	—	—
BTAS 317SV	2-1/8 ODF	A3F Filter	29.0	19.0	13.0	8.1	4.3	26.9	17.3	11.5	7.1	3.6	—	—	—	—	—
BTAS 411SV	1-3/8 ODF	A4F Filter	31.0	20.0	14.0	8.7	4.6	28.7	18.2	12.4	7.6	3.8	—	—	—	—	—
BTAS 413SV	1-5/8 ODF	A4F Filter	38.0	25.0	17.0	11.0	5.7	35.2	22.7	15.1	9.6	4.7	—	—	—	—	—
BTAS 417SV	2-1/8 ODF	A4F Filter	53.0	34.0	23.0	15.0	7.8	49.1	30.9	20.4	13.1	6.5	—	—	—	—	—
BTAS 421SV	2-5/8 ODF	A4F Filter	64.0	42.0	29.0	18.0	10.0	59.3	38.2	25.7	15.7	8.3	—	—	—	—	—
BTAS 517SV	2-1/8 ODF	A5F Filter	63.0	41.0	28.0	18.0	9.4	58.4	37.3	24.8	15.7	7.8	—	—	—	—	—
BTAS 521SV	2-5/8 ODF	A5F Filter	84.0	54.0	37.0	23.0	12.0	77.9	49.1	32.8	20.0	10.0	—	—	—	—	—
BTAS 525SV	3-1/8 ODF	A5F Filter	103.0	67.0	46.0	29.0	15.0	95.5	60.9	40.7	25.3	12.5	—	—	—	—	—
BTAS 25SV	5/8 ODF	A2F-D Filter Drier	4.6	3.0	2.0	1.3	0.7	4.3	2.7	1.8	1.1	0.6	—	—	—	—	—
BTAS 27SV	7/8 ODF	A2F-D Filter Drier	7.5	4.9	3.3	2.1	1.1	7.0	4.5	2.9	1.8	0.9	—	—	—	—	—
BTAS 39SV	1-1/8 ODF	A3F-D Filter Drier	10.0	6.3	4.3	2.7	1.4	9.3	5.7	3.8	2.4	1.2	—	—	—	—	—
BTAS 311SV	1-3/8 ODF	A3F-D Filter Drier	14.0	8.9	6.0	3.8	2.0	13.0	8.1	5.3	3.3	1.7	—	—	—	—	—
BTAS 313SV	1-5/8 ODF	A3F-D Filter Drier	20.0	13.0	8.6	5.4	2.9	18.5	11.8	7.6	4.7	2.4	—	—	—	—	—
BTAS 317SV	2-1/8 ODF	A3F-D Filter Drier	23.0	15.0	10.0	6.3	3.4	21.3	13.6	8.9	5.5	2.8	—	—	—	—	—
BTAS 411SV	1-3/8 ODF	A4F-D Filter Drier	28.0	18.0	13.0	7.8	4.2	26.0	16.4	11.5	6.8	3.5	—	—	—	—	—
BTAS 413SV	1-5/8 ODF	A4F-D Filter Drier	29.0	19.0	14.0	8.1	4.3	26.9	17.3	11.5	7.1	3.6	—	—	—	—	—
BTAS 417SV	2-1/8 ODF	A4F-D Filter Drier	43.0	28.0	19.0	12.0	6.3	39.0	25.5	16.8	10.5	5.2	—	—	—	—	—
BTAS 421SV	2-5/8 ODF	A4F-D Filter Drier	44.0	29.0	20.0	13.0	6.5	41.0	26.4	18.0	11.0	5.4	—	—	—	—	—
BTAS 517SV	2-1/8 ODF	A5F-D Filter Drier	51.0	33.0	22.0	14.0	7.5	47.3	30.0	19.5	12.2	6.2	—	—	—	—	—
BTAS 521SV	2-5/8 ODF	A5F-D Filter Drier	61.0	40.0	27.0	17.0	9.0	56.5	36.4	23.9	14.8	7.5	—	—	—	—	—
BTAS 525SV	3-1/8 ODF	A5F-D Filter Drier	72.0	47.0	32.0	20.0	11.0	66.7	42.7	28.3	17.4	9.2	—	—	—	—	—
STAS 489SV	1-1/8 ODF	(1) F-48 Filter	22.0	14.0	10.0	6.0	2.0	20.0	13.0	9.0	5.0	2.0	27.0	17.0	12.0	7.4	2.5
STAS 4811SV	1-3/8 ODF	(1) F-48 Filter	28.0	17.0	12.0	7.0	3.0	26.0	15.0	11.0	6.0	2.0	34.0	21.0	15.0	8.6	3.7
STAS 4813SV	1-5/8 ODF	(1) F-48 Filter	35.0	20.0	15.0	8.0	4.0	32.0	18.0	13.0	7.0	3.0	43.0	24.0	18.0	9.8	4.9
STAS 4817SV	2-1/8 ODF	(1) F-48 Filter	47.0	30.0	20.0	10.0	5.0	44.0	27.0	18.0	9.0	4.0	57.0	36.0	24.0	12.0	6.2
STAS 4821SV	2-5/8 ODF	(1) F-48 Filter	60.0	40.0	25.0	15.0	7.0	56.0	36.0	22.0	13.0	6.0	73.0	48.0	30.0	18.0	8.6
STAS 9617SV	2-1/8 ODF	(2) F-48 Filter	50.0	30.0	20.0	12.0	6.0	46.0	27.0	18.0	10.0	5.0	61.0	36.0	24.0	15.0	7.4
STAS 9621SV	2-5/8 ODF	(2) F-48 Filter	70.0	43.0	28.0	17.0	8.0	65.0	39.0	25.0	15.0	7.0	85.0	52.0	34.0	21.0	9.9
STAS 9625SV	3-1/8 ODF	(2) F-48 Filter	83.0	51.0	33.0	20.0	10.0	77.0	46.0	30.0	18.0	8.5	101.0	62.0	41.0	25.0	12.0
STAS 489SV	1-1/8 ODF	(1) 48 cu in Core	15.0	9.0	7.0	4.0	1.0	14.0	8.0	6.0	3.0	1.0	18.0	11.0	8.5	4.9	1.2
STAS 4811SV	1-3/8 ODF	(1) 48 cu in Core	18.0	11.0	8.0	5.0	2.0	17.0	10.0	7.0	4.0	2.0	22.0	13.0	9.7	6.1	2.5
STAS 4813SV	1-5/8 ODF	(1) 48 cu in Core	23.0	13.0	10.0	6.0	3.0	21.0	12.0	9.0	5.0	2.0	28.0	16.0	12.0	7.4	3.7
STAS 4817SV	2-1/8 ODF	(1) 48 cu in Core	31.0	20.0	13.0	7.0	4.0	29.0	18.0	12.0	6.0	3.0	38.0	24.0	16.0	9.0	4.5
STAS 4821SV	2-5/8 ODF	(1) 48 cu in Core	40.0	27.0	17.0	10.0	5.0	37.0	25.0	15.0	9.0	4.0	49.0	33.0	21.0	12.0	6.2
STAS 9617SV	2-1/8 ODF	(2) 48 cu in Core	33.0	20.0	13.0	8.0	4.0	31.0	18.0	12.0	7.0	3.0	40.0	24.0	16.0	9.8	4.9
STAS 9621SV	2-5/8 ODF	(2) 48 cu in Core	47.0	28.0	18.0	11.0	6.0	44.0	25.0	16.0	10.0	5.0	57.0	34.0	22.0	14.0	7.4
STAS 9625SV	3-1/8 ODF	(2) 48 cu in Core	51.0	30.0	24.0	17.0	7.6	47.0	27.0	20.0	15.0	6.0	62.0	37.0	28.0	20.0	11.0

<sup>1</sup> All ratings in accordance with ARI Standard 730-04.

<sup>2</sup> Example: 1.0 tons x 3.5 = 3.5 kW

# TAKE-APART SUCTION LINE FILTER DRIER FLOW CAPACITIES

Model number	Connections (in)	Filter drier cartridge	Flow capacity in tons refrigerant <sup>1</sup> (for kw, multiply tons by 3.5) <sup>2</sup>									
			R-502					R-404A / R-507				
			Evaporator temperature (°f)									
			40	20	0	-20	-40	40	20	0	-20	-40
			Pressure drop (psi)									
3	2	1.5	1	0.5	3	2	1.5	1	0.5			
ADKS 30013T	1-5/8 ODF	(3) F-100 Filter	38.0	24.0	16.0	9.9	5.2	37.0	24.0	16.0	10.0	5.5
ADKS 30017T	2-1/8 ODF	(3) F-100 Filter	64.0	40.0	27.0	17.0	8.9	62.0	40.0	27.0	18.0	9.4
ADKS 40017T	2-1/8 ODF	(4) F-100 Filter	68.0	43.0	28.0	17.0	9.2	66.0	43.0	29.0	18.0	9.8
ADKS 40021T	2-5/8 ODF	(4) F-100 Filter	102.0	64.0	43.0	27.0	14.0	99.0	64.0	43.0	28.0	15.0
ADKS 30013T	1-5/8 ODF	(3) 100 cu in Core	30.0	19.0	12.0	7.7	4.1	29.0	19.0	13.0	8.0	4.3
ADKS 30017T	2-1/8 ODF	(3) 100 cu in Core	47.0	30.0	20.0	12.0	6.4	46.0	30.0	20.0	13.0	6.8
ADKS 40017T	2-1/8 ODF	(4) 100 cu in Core	51.0	32.0	22.0	13.0	7.0	49.0	32.0	22.0	14.0	7.4
ADKS 40021T	2-5/8 ODF	(4) 100 cu in Core	74.0	47.0	31.0	19.0	10.0	72.0	47.0	32.0	20.0	11.0
BTAS 27SV	7/8 ODF	A2F Filter	7.4	4.6	3.1	1.8	0.9	7.2	4.6	3.1	1.9	1.0
BTAS 39SV	1-1/8 ODF	A3F Filter	11.0	7.0	4.7	2.8	1.4	11.0	7.0	4.7	2.9	1.5
BTAS 311SV	1-3/8 ODF	A3F Filter	12.0	7.8	5.2	3.1	1.6	12.0	7.8	5.2	3.2	1.7
BTAS 313SV	1-5/8 ODF	A3F Filter	20.0	12.0	8.2	5.0	2.5	19.0	12.0	8.3	5.2	2.7
BTAS 317SV	2-1/8 ODF	A3F Filter	25.0	15.0	10.0	6.1	3.1	24.0	15.0	10.0	6.3	3.3
BTAS 411SV	1-3/8 ODF	A4F Filter	27.0	16.0	11.0	6.6	3.4	26.0	16.0	11.0	6.8	3.6
BTAS 413SV	1-5/8 ODF	A4F Filter	32.0	20.0	13.0	8.1	4.1	31.0	20.0	14.0	8.4	4.4
BTAS 417SV	2-1/8 ODF	A4F Filter	44.0	28.0	18.0	11.0	5.7	43.0	28.0	19.0	12.0	6.0
BTAS 421SV	2-5/8 ODF	A4F Filter	54.0	34.0	23.0	14.0	6.9	52.0	34.0	23.0	14.0	7.3
BTAS 517SV	2-1/8 ODF	A5F Filter	54.0	33.0	22.0	13.0	6.8	52.0	33.0	22.0	14.0	7.2
BTAS 521SV	2-5/8 ODF	A5F Filter	70.0	44.0	29.0	18.0	9.0	68.0	44.0	29.0	18.0	9.6
BTAS 525SV	3-1/8 ODF	A5F Filter	87.0	54.0	36.0	22.0	11.0	84.0	54.0	36.0	23.0	12.0
BTAS 25SV	5/8 ODF	A2F-D Filter Drier	3.9	2.4	1.6	1.0	0.5	3.8	2.4	1.6	1.0	0.5
BTAS 27SV	7/8 ODF	A2F-D Filter Drier	6.3	3.9	2.6	1.5	0.8	6.1	3.9	2.6	1.6	0.9
BTAS 39SV	1-1/8 ODF	A3F-D Filter Drier	8.1	5.1	3.4	2.0	1.0	7.9	5.1	3.4	2.1	1.1
BTAS 311SV	1-3/8 ODF	A3F-D Filter Drier	11.0	7.1	4.8	2.9	1.5	11.0	7.1	4.8	3.0	1.6
BTAS 313SV	1-5/8 ODF	A3F-D Filter Drier	16.0	10.0	6.7	4.1	2.1	16.0	10.0	6.8	4.2	2.2
BTAS 317SV	2-1/8 ODF	A3F-D Filter Drier	19.0	12.0	7.9	4.8	2.4	19.0	12.0	8.0	5.0	2.6
BTAS 411SV	1-3/8 ODF	A4F-D Filter Drier	24.0	15.0	10.0	5.9	3.0	23.0	15.0	10.0	6.1	3.2
BTAS 413SV	1-5/8 ODF	A4F-D Filter Drier	25.0	15.0	10.0	6.1	3.1	24.0	15.0	10.0	6.3	3.3
BTAS 417SV	2-1/8 ODF	A4F-D Filter Drier	36.0	22.0	15.0	9.0	4.6	35.0	22.0	15.0	9.3	4.9
BTAS 421SV	2-5/8 ODF	A4F-D Filter Drier	37.0	23.0	16.0	10.0	5.0	36.0	23.0	16.0	10.0	5.3
BTAS 517SV	2-1/8 ODF	A5F-D Filter Drier	42.0	27.0	18.0	11.0	4.7	41.0	27.0	18.0	11.0	5.0
BTAS 521SV	2-5/8 ODF	A5F-D Filter Drier	52.0	32.0	22.0	13.0	6.6	50.0	32.0	22.0	13.0	7.0
BTAS 525SV	3-1/8 ODF	A5F-D Filter Drier	61.0	38.0	25.0	15.0	7.8	59.0	38.0	25.0	16.0	8.3
STAS 489SV	1-1/8 ODF	(1) F-48 Filter	21.0	12.0	8.0	5.0	3.0	20.0	12.0	8.0	5.0	3.0
STAS 4811SV	1-3/8 ODF	(1) F-48 Filter	25.0	15.0	10.0	6.0	4.0	24.0	15.0	10.0	6.0	4.0
STAS 4813SV	1-5/8 ODF	(1) F-48 Filter	31.0	18.0	11.0	7.0	5.0	30.0	18.0	11.0	7.0	5.0
STAS 4817SV	2-1/8 ODF	(1) F-48 Filter	41.0	25.0	15.0	9.0	7.0	40.0	25.0	15.0	9.0	7.0
STAS 4821SV	2-5/8 ODF	(1) F-48 Filter	57.0	30.0	20.0	12.0	8.0	55.0	30.0	20.0	12.0	8.0
STAS 9617SV	2-1/8 ODF	(2) F-48 Filter	41.0	25.0	15.0	10.0	7.0	40.0	25.0	15.0	10.0	7.0
STAS 9621SV	2-5/8 ODF	(2) F-48 Filter	62.0	35.0	25.0	14.0	9.0	60.0	35.0	25.0	15.0	10.0
STAS 9625SV	3-1/8 ODF	(2) F-48 Filter	74.0	42.0	30.0	17.0	11.0	72.0	42.0	30.0	18.0	12.0
STAS 489SV	1-1/8 ODF	(1) 48 cu in Core	13.0	8.0	6.0	4.0	2.0	13.0	8.0	6.0	4.0	2.0
STAS 4811SV	1-3/8 ODF	(1) 48 cu in Core	18.0	10.0	6.5	4.5	3.0	17.0	10.0	6.5	4.5	3.0
STAS 4813SV	1-5/8 ODF	(1) 48 cu in Core	21.0	12.0	7.0	5.0	4.0	20.0	12.0	7.0	5.0	4.0
STAS 4817SV	2-1/8 ODF	(1) 48 cu in Core	28.0	17.0	10.0	6.0	5.0	27.0	17.0	10.0	6.0	5.0
STAS 4821SV	2-5/8 ODF	(1) 48 cu in Core	38.0	20.0	13.0	8.0	6.0	37.0	20.0	13.0	8.0	6.0
STAS 9617SV	2-1/8 ODF	(2) 48 cu in Core	28.0	17.0	11.0	7.0	5.0	27.0	17.0	11.0	7.0	5.0
STAS 9621SV	2-5/8 ODF	(2) 48 cu in Core	41.0	23.0	17.0	10.0	7.0	40.0	23.0	17.0	10.0	7.0
STAS 9625SV	3-1/8 ODF	(2) 48 cu in Core	49.0	27.0	20.0	12.0	8.0	47.0	27.0	20.0	12.0	8.0

<sup>1</sup> All ratings in accordance with ARI Standard 730-04.

<sup>2</sup> Example: 1.0 tons x 3.5 = 3.5 kW



HMI 1TT5

# HMI Series Hermetic Moisture Indicators

The HMI is designed to provide an accurate method of determining the moisture content of a system's refrigerant. The HMI has a unique high accuracy moisture indicator for CFC, HCFC, and HFC refrigerants.

## Features

- Highest sensitivity moisture indicator available
- Hermetic construction for leak-free operation
- Single indicator for all common refrigerants
- Accurate color calibration at low ppm levels and higher temperatures
- Wide angle viewing/high visibility window for ease of monitoring
- All brass corrosion resistant body
- Solid copper connections

## Specifications

Maximum working pressure .....680 psig (47 bar)  
 UL/CUL file number.....SA9566  
 Canadian CRN.....0F20663.5C

### Model number nomenclature - Example: HMI 1TT4

Series	Design	Connection type	Connection size	Sequential identifier	Customer special	Pack type
HMI	1	TT	4			
Hermetic Moisture Indicator	1 = Standard	FM = Female Flare X Male Flare MM = Male Flare X Male Flare TT = ODF Extended Ends TT_MF = ODM x ODF Extended Ends	In 1/8" Increments	Blank Thru -99	G = Customer Special (Omit for Standard)	B1 = Bulk Pack (Omit for Individual Pack)

### HMI Series Hermetic Moisture Indicators

Connection style	Connection size	Model number	Item number
Female Flare X Male Flare	1/4"	HMI 1FM2	065396
Female Flare X Male Flare	3/8"	HMI 1FM3	065397
Female Flare X Male Flare	1/2"	HMI 1FM4	065398
Male Flare X Male Flare	1/4"	HMI 1MM2	065391
Male Flare X Male Flare	3/8"	HMI 1MM3	065392
Male Flare X Male Flare	1/2"	HMI 1MM4	065393
Male Flare X Male Flare	5/8"	HMI 1MM5	065394
Male Flare X Male Flare	3/4"	HMI 1MM6	065395
ODF Extended Ends	1/4"	HMI 1TT2	065405
ODF Extended Ends	3/8"	HMI 1TT3	065406
ODF Extended Ends	1/2"	HMI 1TT4	065407
ODF Extended Ends	5/8"	HMI 1TT5	065408
ODF Extended Ends	3/4"	HMI 1TT6	065409
ODF Extended Ends	7/8"	HMI 1TT7	065410
ODF Extended Ends	1-1/8"	HMI 1TT9	065411

Moisture content color code (PPM H<sub>2</sub>O)

Indication liquid temperature	Dry (dark blue)			Caution (purple)			Wet (salmon)		
	75°F	100°F	125°F	75°F	100°F	125°F	75°F	100°F	125°F
R-12	1.4	2.5	4	5	9	15	25	43	70
R-134A	20	35	60	35	55	85	130	160	190
R-22	25	35	50	40	65	90	145	205	290
R-407C	26	40	64	42	68	109	150	230	370
R-410A	30	55	75	50	85	120	165	290	420
R-404A / 507	15	25	45	33	50	80	120	150	180
R-448A/R-449A	22	31	43	37	52	72	141	203	282
R-450A/R-513A	13	18	25	22	30	42	82	118	164

Indication liquid temperature	Dry (dark blue)				Caution (purple)				Wet (salmon)			
	-40°F	-4°F	32°F	68°F	-40°F	-4°F	32°F	68°F	-40°F	-4°F	32°F	68°F
R-744	3	6	11	20	5	10	19	34	16	32	63	116



AMI 1FM3

# AMI Series Take-Apart Moisture Indicators

The AMI is designed to provide an accurate method of determining the moisture content of a system's refrigerant. The AMI has a unique high accuracy moisture indicator for CFC, HCFC and HFC refrigerants.

## Features

- Highest sensitivity moisture indicator available
- Take-Apart design for easy repair
- Single indicator for all common refrigerants
- Accurate color calibration at low ppm levels and higher temperatures
- Wide angle viewing/high visibility window for ease of monitoring
- Solid copper connections

## Specifications

Maximum working pressure ..... 680 psig (47 bar)  
 UL/CUL file number ..... SA9566  
 Canadian CRN ..... 0F20663.5C

### Model number nomenclature - Example: AMI 1SS4

Series	Design	Connection type	Connection size	Sequential identifier	Customer special	Pack type
AMI	1	SS	4			
Take-Apart Moisture Indicator	1 = Standard Connection 2 = Bushing Style	FM = Female Flare X Male Flare MM = Male Flare X Male Flare SS = Sweat X Sweat (ODF) TT = ODF Extended Ends	In 1/8" Increments	Blank Thru -99	G = Customer Special (Omit for Standard)	B1 = Bulk Pack (Omit for Individual Pack)

### AMI Series Moisture Indicators

Connection type	Connection size	Model number	Item number
Female Flare X Male Flare	1/4"	AMI 1FM2	048800
	3/8"	AMI 1FM3	048801
	1/2"	AMI 1FM4	048802
Male Flare X Male Flare	3/8"	AMI 1MM3	048804
	1/2"	AMI 1MM4	048805
	5/8"	AMI 1MM5	048806
Sweat X Sweat (ODF)	1/4"	AMI 1SS2	048811
	3/8"	AMI 1SS3	048812
	1/2"	AMI 1SS4	048813
	5/8"	AMI 1SS5	048814
	7/8"	AMI 1SS7	048815
	1-1/8"	AMI 1SS9	048816
ODF Extended Ends	1/4"	AMI 1TT2	047298
	3/8"	AMI 1TT3	042771
	1/2"	AMI 1TT4	022302
	5/8"	AMI 1TT5	031136
	7/8"	AMI 1TT7	031357
	1-1/8"	AMI 1TT9	031578
	1-3/8"	AMI 1TT11	060255
Bushing Style (ODM)	7/8"	AMI 2S7	064167
	1-1/8"	AMI 2S9	064168
	1-3/8"	AMI 2S11	022303
	1-5/8"	AMI 2S13	028388
	2-1/8"	AMI 2S17	031219

Moisture content color code (PPM H<sub>2</sub>O)

Indication liquid temperature	Dry (dark blue)			Caution (purple)			Wet (salmon)		
	75°F	100°F	125°F	75°F	100°F	125°F	75°F	100°F	125°F
R-12	1.4	2.5	4	5	9	15	25	43	70
R-134A	20	35	60	35	55	85	130	160	190
R-22	25	35	50	40	65	90	145	205	290
R-407C	26	40	64	42	68	109	150	230	370
R-410A	30	55	75	50	85	120	165	290	420
R-404A / 507	15	25	45	33	50	80	120	150	180
R-448 / 449	22	31	43	37	52	72	141	203	282
R-450A / R513A	13	18	25	22	30	42	82	118	164

Indication liquid temperature	Dry (dark blue)				Caution (purple)				Wet (salmon)			
	-40°F	-4°F	32°F	68°F	-40°F	-4°F	32°F	68°F	-40°F	-4°F	32°F	68°F
R-744	3	6	11	20	5	10	19	34	16	32	63	116

AMI series parts

Description	Model number	Item number
Lens cap	12740-1	021371
"O" Ring	PS-1525-2	020877
Lens Assembly Kit (Consists of Lens Assembly, Lens Cap, and "O" Ring)	X-12978-1	027511



A-IHL 13S

# A-IHL Series Moisture Indicators

The A-IHL saddle design moisture indicator is used for large diameter tubing in CFC, HCFC and HFC refrigerants.

## Features

- Saddle design
- Solid copper connections
- Replaceable moisture indicator
- Eliminates the need for bypass installation - positive reaction to system moisture levels

## Specifications

Maximum working pressure .....680 psig (47 bar)  
 UL/CUL file number .....SA9566  
 Canadian CRN.....0F20663.5C

### Model number nomenclature - Example: A-IHL 9S

Series	Connection size	Connection type	Sequential identifier	Customer special	Pack type
A-IHL	9	S			
Large Diameter Tubing Moisture Indicator	In 1/8" Increments	S = ODF	Blank Thru -99	G = Customer Special (Omit for Standard)	B1 = Bulk Pack (Omit for Individual Pack)

### A-IHL Series Moisture Indicators

Connection type	Connection size	Length	Model number	Item number
ODF	1-1/8"	6.31"	A-IHL 9S	060853
ODF	1-3/8"	7.12"	A-IHL 11S	061030
ODF	1-5/8"	7.87"	A-IHL 13S	061031
ODF	2-1/8"	8.68"	A-IHL 17S	061032



APD 165SB

# APD Series Pulsation Dampener / Muffler

The APD Series is designed to reduce noise and vibration on the compressor discharge lines.

## Features

- Compact size
- Full flow fittings
- Solid copper connections
- Corrosion resistant epoxy powder paint finish
- Rugged steel shells for vibration resistance
- Shock resistant steel shell construction
- Compatible with all common A1 (except R-744), A2L, and A3 class refrigerants

## Specifications

Maximum working pressure ..... 680 psig (47 bar)  
 Operating range ..... -40°F/C to +250°F (121 °C)  
 UL/CUL file number ..... SA5760

### Model number nomenclature - Example: APD 054SB

Series	Unit size	Connection size	Connection style	Baffles	Sequential identifier	Customer special	Pack type
APD	05	4	S	B			
Pulsation Dampener	In Cubic In.	In 1/8" Increments	S = ODF F = SAE	B = With Baffles  (Omit for Standard)	Blank Thru -99	G = Customer Special  (Omit for Standard)	B1 = Bulk Pack  (Omit for Individual Pack)

### APD Series Mufflers

Inlet x outlet connection size	Baffles	Model number	Item number
1/2" X 1/2" ODF	Yes	APD 054SB	049651
3/8" X 3/8" ODF	No	APD 163S	059144
5/8" X 5/8" ODF	Yes	APD 165SB	060119
7/8" X 7/8" ODF	Yes	APD 167SB	061042
1-1/8" X 1-1/8" ODF	No	APD 309S	056989



A-AS 597

# A-AS Series Suction Accumulators

The A-AS protects the compressor from liquid slugging and is used with CFC, HCFC and HFC refrigerants. It is available for systems through 28 tons nominal capacity.

## Features

- Designed to operate in a range of +40°F to -40°F evaporator temperature
- Fusible plug on larger diameter units
- Solid copper connections
- Corrosion resistant epoxy powder paint finish
- Inlet deflector directs refrigerant flow to prevent internal splashing and aid in the collection of refrigerant oil

## Specifications

Maximum working pressure .....450 psig (31 bar)  
 Fusible plug temperature.....430°F (221°C)  
 UL/CUL file number.....SA 10225  
 Canadian CRN.....0H20236-5C

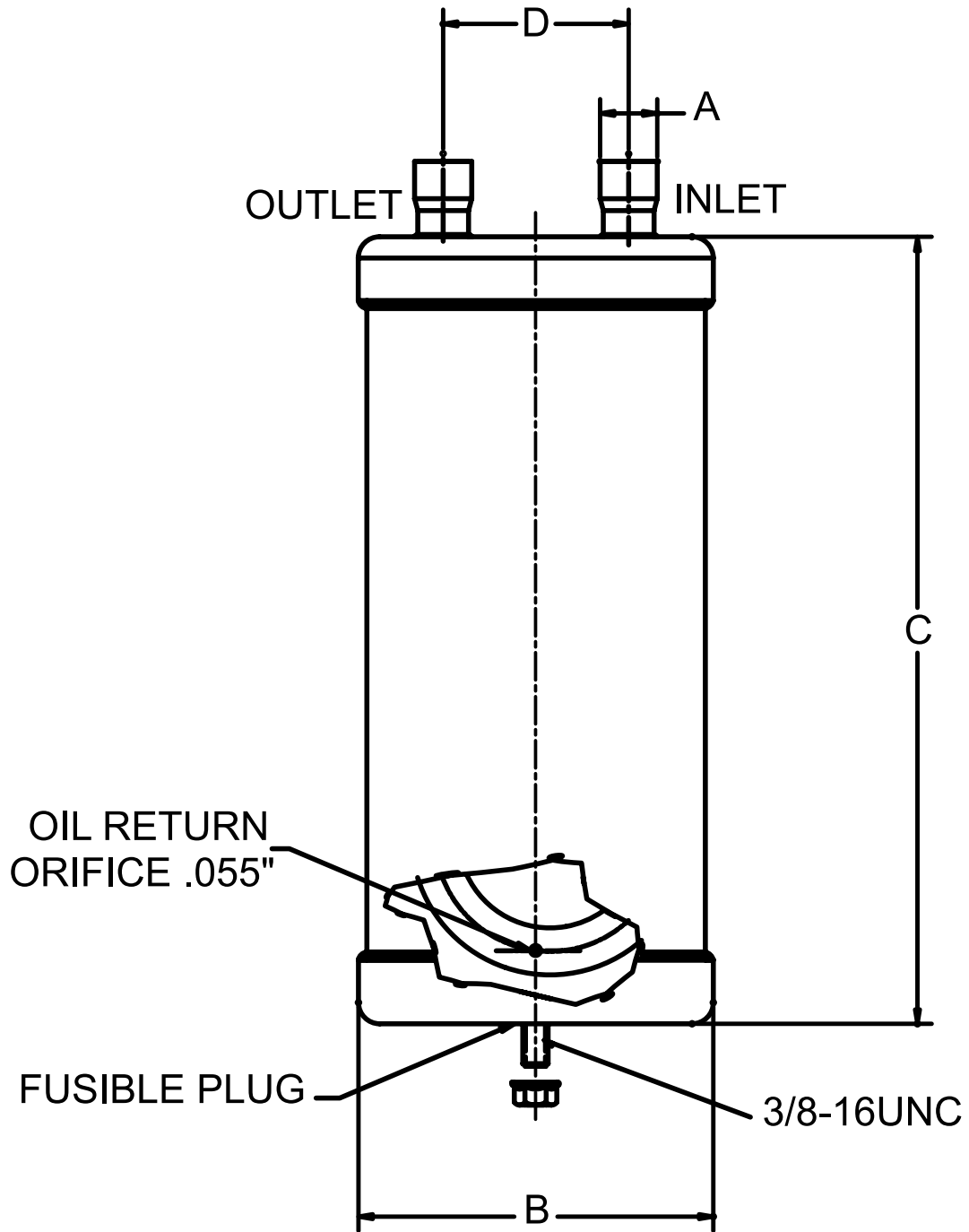
Model number nomenclature - Example: A-AS 3125

Series	Accumulator suction	Diameter	Height	Fitting size	Sequential identifier	Customer special	Pack type
A	AS	3	12	5			
Suction Accumulators		In Cubic In.	In Cubic In.	Fitting Size In 1/8" Increments	Blank Thru -99	G = Customer Special (Omit for Standard)	B1 = Bulk Pack P1 = Pallet Pack (Omit for Individual Pack)

## A-AS Series Suction Accumulators

(B) diam. (in)	(C) height (in)	(A) fitting size	(D) fitting sep. (in)	Flow capacity tons (+40°F)		Holding capacity (lbs) 50% of system charge 40°F liquid										Model number	Order number
				R-404A	R-410A	R-22 R-134A	R-407C R-407A	R-404A R-507	R-448A R-449A	R-450A R-513A	R-32 R-454B	R-454A R-454C R-455A"	R-410A	R-290	R-600A		
3	8	1/2" ODF	1.63	1.7	2.4	1.1	1	1	1	1	0.9	0.9	1	0.4	0.5	A-AS 384	060819
3	10	5/8" ODF	1.63	2.6	3.7	1.4	1.3	1.2	1.3	1.3	1.1	1.2	1.2	0.6	0.6	A-AS 3105	060963
3	12	5/8" ODF	1.63	2.6	3.7	1.7	1.6	1.5	1.5	1.6	1.4	1.4	1.5	0.7	0.8	A-AS 3125	060812
3	12	3/4" ODF	1.63	3.5	4.9	1.7	1.6	1.5	1.5	1.6	1.4	1.4	1.5	0.7	0.8	A-AS 3126	060813
3	14	5/8" ODF	1.63	2.6	3.7	2	1.9	1.7	1.8	1.9	1.6	1.7	1.8	0.8	0.9	A-AS 3145	060964
3	14	3/4" ODF	1.63	3.5	4.9	2	1.9	1.7	1.8	1.9	1.6	1.7	1.8	0.8	0.9	A-AS 3146	060965
4	6	1/2" ODF	2.50	1.7	2.4	1.4	1.3	1.2	1.3	1.4	1.1	1.2	1.3	0.6	0.6	A-AS 464	060967
4	6	5/8" ODF	2.50	2.6	3.7	1.4	1.3	1.2	1.3	1.4	1.1	1.2	1.3	0.6	0.6	A-AS 465	060821
4	10	5/8" ODF	2.50	2.6	3.7	2.4	2.3	2.2	2.3	2.4	2	2.1	2.2	1	1.1	A-AS 4105	060966
4	10	3/4" ODF	2.50	3.5	4.9	2.4	2.3	2.2	2.3	2.4	2	2.1	2.2	1	1.1	A-AS 4106	060820
5	9	3/4" ODF	2.75	3.5	4.9	3.3	3.2	3	3.1	3.3	2.7	2.9	3	1.4	1.5	A-AS 596	060824
5	9	7/8" ODF	2.75	6.4	8.9	3.3	3.2	3	3.1	3.3	2.7	2.9	3	1.4	1.5	A-AS 597	060818
5	12	3/4" ODF	2.75	3.5	4.9	4.6	4.4	4.1	4.3	4.5	3.8	4	4.2	1.9	2.1	A-AS 5126	060822
5	12	7/8" ODF	2.75	6.4	8.9	4.6	4.4	4.1	4.3	4.5	3.8	4	4.2	1.9	2.1	A-AS 5127	060823
5	13	7/8" ODF	2.75	6.4	8.9	5	4.8	4.5	4.7	4.9	4.1	4.4	4.6	2.1	2.3	A-AS 5137	060814
5	13	1-1/8" ODF	2.75	10.3	14.5	5	4.8	4.5	4.7	4.9	4.1	4.4	4.6	2.1	2.3	A-AS 5139	060815
5	17	1-1/8" ODF	2.75	10.3	14.5	6.7	6.5	6	6.3	6.6	5.5	5.8	6.1	2.8	3	A-AS 5179	060817
5	17	1-3/8" ODF	2.75	16.4	23	6.7	6.5	6	6.3	6.6	5.5	5.8	6.1	2.8	3	A-AS 51711	060816
6	11	7/8" ODF	2.94	6.4	8.9	6.1	5.8	5.4	5.7	9.6	5	5.3	5.5	2.5	2.8	A-AS 6117	060825
6	13	7/8" ODF	2.94	6.4	8.9	7.2	6.9	6.4	6.7	12.3	5.9	6.2	6.5	3	3.3	A-AS 6137	060826
6	13	1-1/8" ODF	2.94	10.3	14.5	7.2	6.9	6.4	6.7	12.3	5.9	6.2	6.5	3	3.3	A-AS 6139	060968
6	14	1-3/8" ODF	2.94	16.4	23	7.8	7.5	7	7.3	13.5	6.4	6.8	7.1	3.2	3.6	A-AS 61411	060827
6	17	1-5/8" ODF	2.94	24.8	34.9	9.6	9.2	8.6	8.9	16.6	7.9	8.3	8.7	3.9	4.3	A-AS 61713	060969
6	20	1-5/8" ODF	2.94	24.8	34.9	11.3	10.9	10.1	10.6	19.7	9.3	9.8	10.3	4.7	5.1	A-AS 62013	060828
6	25	1-5/8" ODF	2.94	24.8	34.9	14.2	13.7	12.7	13.3	24.7	11.7	12.4	13	5.9	6.5	A-AS 62513	060970

Dimensional data





BVS 078 806758

# BV Series Ball Valves

The BVE/BVS Series refrigeration ball valves isolate suction, discharge, and liquid lines during maintenance shutdown periods.

## Features

- Forged brass body with extended copper ODF connections
- Compact, lightweight, hermetic welded design
- Compatible with all A1 class and A2L class refrigerants/lubricants, as well as R-290 and R-744
- Full port design below 2" port size
- Bi-directional flow characteristics
- Valve stem cap retained by strap attached to main body
- Integrated access valve available on all sizes
- Low operating friction design

## Specifications

Maximum working pressure ..... 650 psig (45 bar)  
 Fluid temperature range ..... -40°F/C to 250°F (121°C), 302°F (150°C) short term  
 UL/CUL file number ..... SA5312  
 Canadian CRN ..... OC21506.513467890YTN

**Model number nomenclature - Example: BVE 118 806739**

Series	Access valve	Connection size		Unique identifier
BV	E	118		806739
Ball Valve Series	E = No S = Yes	'014 = 1/4" '038 = 3/8" '012 = 1/2" '058 = 5/8" '034 = 3/4" '078 = 7/8"	'118 = 1-1/8" '138 = 1-3/8" '158 = 1-5/8" '218 = 2-1/8" '258 = 2-5/8"	

## BV Series Ball Valves

Connection size and type	Port size	Lay in length (in)	Without access valve		With access valve	
			Model number	Item number	Model number	Item number
1/4" ODF	Full Port	4.72	BVE 014 806730	806730	BVS 014 806750	806750
3/8" ODF	Full Port	4.72	BVE 038 806732	806732	BVS 038 806752	806752
1/2" ODF	Full Port	5.00	BVE 012 806734	806734	BVS 012 806754	806754
5/8" ODF	Full Port	5.00	BVE 058 806736	806736	BVS 058 806756	806756
3/4" ODF	Full Port	6.18	BVE 034 806737	806737	BVS 034 806757	806757
7/8" ODF	Full Port	6.18	BVE 078 806738	806738	BVS 078 806758	806758
1-1/8" ODF	Full Port	6.65	BVE 118 806739	806739	BVS 118 806759	806759
1-3/8" ODF	Full Port	9.09	BVE 138 806741	806741	BVS 138 806761	806761
1-5/8" ODF	Full Port	10.91	BVE 158 806742	806742	BVS 158 806762	806762
2-1/8" ODF	2" Port	11.69	BVE 218 806744	806744	BVS 218 806764	806764
2-5/8" ODF	2" Port	11.69	BVE 258 806745	806745	BVS 258 806765	806765

## BV-series parts list

Description	Quantity (per pack)	Model number	Item number
bV Series Small Locking Seal Caps for Valve Sizes 1/4" Thru 7/8"	10 pcs.	BV 806770	806770
BV Series Medium Locking Seal Caps for Valve Sizes 1-1/8" Thru 1-3/8"	10 pcs.	BV 806771	806771
BV Series Large Locking Seal Caps for Valve Sizes 1-5/8" Thru 2-5/8"	10 pcs.	BV 806772	806772



**BVSS 012**

# BVSS Series Ball Valves

The BVSS Series refrigeration ball valves isolate suction, discharge, and liquid lines during maintenance shut down periods.

## Features

- Forged brass body and copper connection with hermetic laser weld design
- Optimized sealing components for leak-proof performance
- Enhanced stop stem and enlarged stop tolerance for better sealing under higher working pressure
- Threaded mounting holes for easy mounting
- Bi-directional flow characteristics
- Compatible with HCFC, HFC, A1, A2L, A3 refrigerants and lubricants
- Integrated access valve on all sizes (core is pre-installed)
- Brass locking seal caps
- Full port design on all sizes
- Compact and lightweight

## Specifications

Maximum working pressure..... 650 psig (45 bar)  
 Fluid temperature range..... -40°F/°C to 248°F (120°C)  
 Ambient temperature range..... -22°F(-30°C) to 140°F (60°C)  
 UL file number..... SA45472

### Model number nomenclature - Example: BVSS 012T

Series	Connection size	Mounting
BVSS	012	T
BVSS = Ball Valve with access valve	'014 = 1/4" '038 = 3/8" '012 = 1/2" '058 = 5/8" '034 = 3/4" '078 = 7/8" '118 = 1-1/8" '138 = 1-3/8" '158 = 1-5/8" '218 = 2-1/8" '258 = 2-5/8"	T = Threaded Mounting Hole

### Ball valve series comparison

Feature	BVSS	BVS	BVE
Access Valve	Yes	Yes	No
Refrigerants	HCFC,HFC,A1,A2L,A3, except R-744	A1 & A2L, R290, R744	
Full Port	All sizes	1/4" through 1-5/8" only	
Locking Seal Cap	Brass	Plastic w/retaining strap	
Length	Standard	-	
Mounting Holes	Yes	Yes	

*BVSS Series Ball Valves*

Connection size and type	Port size	Overall length (in)	Model number	Item number
1/4" ODF	Full Port	4.41	BVSS-014T	081065
3/8" ODF	Full Port	4.96	BVSS-038T	081066
1/2" ODF	Full Port	5.02	BVSS-012T	081067
5/8" ODF	Full Port	5.91	BVSS-058T	081068
3/4" ODF	Full Port	6.46	BVSS-034T	081069
7/8" ODF	Full Port	7.46	BVSS-078T	081070
1-1/8" ODF	Full Port	8.23	BVSS-118T	081071
1-3/8" ODF	Full Port	9.69	BVSS-138T	081072
1-5/8" ODF	Full Port	10.98	BVSS-158T	081073
2-1/8" ODF	Full Port	12.6	BVSS-218T	081074
2-5/8" ODF	Full Port	14.84	BVSS-258T	081075
3-1/8" ODF	Full Port	16.14	BVSS-318T	081076



ACK 4

# ACK Series Check Valve

The ACK check valve is a normally closed magnetic check valve that prevents reverse refrigerant flow in liquid lines and compressor discharge lines.

## Features

- Copper connection sizes 1/4" through 2-5/8"
- Hermetic spun copper design
- Magnetic checking action
- Built-in 30 mesh stainless steel strainer
- Can be installed in any position
- Compatible with all A1 and A2L class refrigerants, as well as R-290 and R-744

## Specifications

Maximum working pressure ..... 680 psig (47 bar)  
 Maximum working pressure (ACK-4 & -6 only)..... 800 psig (55 bar)  
 Approvals..... UL/CUL File Number SA5312

Model number nomenclature - Example: ACK-4

Series	Connection size
ACK	4
Check Valve Series	Copper ODF Connection Size (in 1/16")

### ACK Series Check Valves

Connection size & type (in)	Nominal tons liquid & suction 40°F @ 1 psi, discharge 2 psi										Cv	Model number	Item number
	R22		R-404A / R-448A / R-449A			R-410A			R-450A / R-513A				
	Liquid	Suction	Liquid	Suction	Discharge	Liquid	Suction	Discharge	Liquid	Suction			
1/4 ODF	2.60	0.40	1.77	0.34	0.59	2.59	0.48	0.80	1.79	0.28	0.9	ACK 4	064985
3/8 ODF	3.10	0.60	2.11	0.50	1.20	3.09	0.72	1.63	2.14	0.42	1	ACK 6	064986
1/2 ODF	9.40	1.20	6.39	1.01	2.23	9.37	1.44	3.01	6.48	0.84	3.1	ACK 8	064987
5/8 ODF	13.00	1.40	8.84	1.18	2.67	12.96	1.68	3.61	8.96	0.98	3.6	ACK 10	064988
3/4 ODF	27.00	3.30	18.36	2.77	5.82	26.92	3.96	7.87	18.62	2.31	8	ACK 12	064989
7/8 ODF	29.00	3.70	19.72	3.11	6.71	28.91	4.44	9.08	20.00	2.59	9.2	ACK 14	064990
1-1/8 ODF	51.00	6.00	34.68	5.04	10.55	50.85	7.20	14.27	35.16	4.20	15.4	ACK 18	064991
1-3/8 ODF	79.00	9.50	53.72	7.98	17.73	78.76	11.4	23.98	54.47	6.65	23.8	ACK 22	064992
1-5/8 ODF	102.00	17.00	69.36	14.28	26.04	101.69	20.4	35.21	70.33	11.89	24.2	ACK 26	064993
2-1/8 ODF	213.00	30.00	144.84	25.20	41.13	212.36	36.00	55.62	146.86	20.99	38.7	ACK 34	064994
2-5/8 ODF	375.00	50.00	255.00	42.00	50.70	373.88	60.00	68.56	258.56	34.98	71.7	ACK 42	064995



A-FC 6221717H

# A-FC / A-WC High Efficiency Centrifugal Oil Separator

The High Efficiency Centrifugal Oil Separator is used in ultra-low temperature systems with long refrigerant lines or inherent oil return problems. It is also used on multiple compressor racks for supermarkets and air conditioning systems for use with CFCs, HCFCs, HFCs, and their lubricants. A-WC Series is suitable for use with R-410A.

## Features

- Internal oil collection screen
- Hermetic welded or accessible bolted flange construction
- Corrosion resistant epoxy powder paint
- High efficiency (99%) centrifugal separation

## Specifications

Maximum working pressure

A-FC..... Flanged Models 450 psi (31 bar)

A-WC..... Welded Models 600 psi (41 bar)

UL/CUL file number..... SA8547

Canadian CRN..... OH20236-5C

Model number nomenclature - Example: A-FC 10272121H

Series	Style	Centrifugal	Shell diameter	Length	Inlet connection	Outlet connection	Leg height	Sequential identifier	Customer Special	Pack type
a	F	C	10	27	21	21	H			
A-WC / A-FC Series	F = Flanged W = Welded	Centrifugal Design	Diameter in Inches	Length in Inches	In 1/8" Increments	In 1/8" Increments	H = 10" <small>(Omit for 5" Standard, 2.95" or no legs)</small>	Blank Thru -99	G = Customer Special <small>(Omit for Standard)</small>	B1 = Bulk Pack <small>(Omit for Individual Pack)</small>

## A-WC / A-FC Series Oil Separators

F = flanged W = welded	Diameter (in)	Overall length (in)	Connection size (odf)	Leg height (in)	Discharge maximum (cfm)	Maximum capacity of refrigeration at evaporator temperature (tons/kw)								Model number	Item number
						R-134A / R-450A / R-513A		R-22 / R-407C / R-448A / R-449A		R-404A / R-507		R-410A			
						-40°F	+40°F	-40°F	+40°F	-40°F	+40°F	-40°F	+40°F		
f	6	22	1-3/8"	5.0	15.9	12.2 (42.8)	14.9 (52.4)	17.6 (61.9)	21.0 (73.9)	16.8 (59.1)	22.1 (77.9)	—	—	A-FC 6221111'	065930
F	6	27	1-3/8"	10.0	15.9	12.2 (42.8)	14.9 (52.4)	17.6 (61.9)	21.0 (73.9)	16.8 (59.1)	22.1 (77.9)	—	—	A-FC 6221111H'	065931
F	6	22	1-5/8"	5.0	24.4	18.7 (65.6)	22.8 (80.3)	27.0 (94.8)	32.2 (113.2)	25.8 (90.6)	33.9 (119.3)	—	—	A-FC 6221313'	065362
F	6	27	1-5/8"	10.0	24.4	18.7 (65.6)	22.8 (80.3)	27.0 (94.8)	32.2 (113.2)	25.8 (90.6)	33.9 (119.3)	—	—	A-FC 6221313H'	065932
F	6	22	2-1/8"	5.0	31.3	23.9 (84.0)	29.2 (102.8)	34.5 (121.4)	41.2 (145.0)	33.3 (116.0)	43.5 (152.8)	—	—	A-FC 6221717'	065933
F	6	27	2-1/8"	10.0	31.3	23.9 (84.0)	29.2 (102.8)	34.5 (121.4)	41.2 (145.0)	33.3 (116.0)	43.5 (152.8)	—	—	A-FC 6221717H'	065934
F	8	24	2-1/8"	5.0	38.1	29.1 (102.3)	35.6 (125.1)	42.0 (147.8)	50.2 (176.5)	40.1 (141.2)	52.9 (186.1)	—	—	A-FC 8241717'	065276
F	8	29	2-1/8"	10.0	38.1	29.1 (102.3)	35.6 (125.1)	42.0 (147.8)	50.2 (176.5)	40.1 (141.2)	52.9 (186.1)	—	—	A-FC 8241717H'	065935
F	12	35	3-1/8"	10.0	88.9	67.9 (238.9)	83.1 (292.1)	98.1 (345.2)	117.2 (412.2)	93.7 (329.7)	123.5 (434.4)	—	—	A-FC 12302525H	065938
W	4	17	7/8"	3.0	6.7	5.1 (18.1)	6.3 (22.1)	7.4 (26.2)	8.9 (31.2)	7.1 (25.0)	9.4 (32.9)	12.2 (42.8)	13.8 (48.3)	A-WC 41777	065895

A-WC / A-FC Series Oil Separators <cont'd>

F = flanged W = welded	Diameter (in)	Overall length (in)	Connection size (odf)	Leg height (in)	Discharge maximum (cfm)	Maximum capacity of refrigeration at evaporator temperature (tons/kw)								Model number	Item number
						R-134A / R-450A / R-513A		R-22 / R-407C / R-448A / R-449A		R-404A / R-507		R-410A			
						-40°F	+40°F	-40°F	+40°F	-40°F	+40°F	-40°F	+40°F		
W	4	19	1-1/8"	3.0	11.6	8.8 (31.0)	10.8 (38.0)	12.8 (44.9)	15.2 (53.6)	12.2 (42.8)	16.1 (56.4)	20.9 (73.4)	23.7 (83.3)	A-WC 41999	065896
W	6	18	1-3/8"	—	15.9	12.2 (42.8)	14.9 (52.4)	17.6 (61.9)	21.0 (73.9)	16.8 (15.1)	22.1 (77.9)	28.8 (101.2)	32.7 (114.9)	A-WC 6181111	066094
W	6	18	1-5/8"	—	24.4	18.7 (65.6)	22.8 (80.3)	27.0 (94.8)	32.2 (113.2)	25.8 (90.6)	33.9 (119.3)	44.1 (155.1)	50.1 (176.0)	A-WC 6181313	066095
W	6	18	2-1/8"	—	31.3	23.9 (84.0)	29.2 (102.8)	34.5 (121.4)	41.2 (145.0)	33.0 (116.0)	43.5 (152.8)	56.5 (198.6)	64.1 (225.4)	A-WC 6181717	066096

<sup>1</sup> Replaceable Float

A-WC / A-FC series parts list

Description	Model number	Item number
Oil Separator Flange Gasket	OIL SEPARATOR KIT	065849
Flange with Integral Float Assembly and Flange Gasket, Repairs A-FC, AF, AC and R Series S1900 Standard and 5200 Helical Oil Separators	FLOAT REPAIR KIT	065847





A-WZ 55889

# A-F / A-W / A-WZ Series Oil Separators

The A-W and A-F are used for multiple compressor racks in supermarkets and air conditioning systems for use with HCFCs, HFCs and their lubricants

## Features

- Hermetic welded or accessible bolted flange construction
- Solid copper connections for A-W and A-F
- Nickel plated steel connections for A-WZ
- Corrosion resistant epoxy powder paint

## Specifications

Maximum working pressure .....	A-W / A-F .....	450 psi (31 bar)
	A-WZ .....	4" shell 600 psig (41 bar)
	A-WZ .....	6" shell 680 psig (47 bar)
UL/CUL file number .....	A-W / A-F .....	SA10468
	A-WZ .....	SA8547
Canadian CRN	(Excludes A-WZ) .....	0H20236-5C
CE marking .....	A-WZ .....	PED 97/23EC

Model number nomenclature - Example: A-F 579213

Series	Connection flare	Style	Unique identifier	Connection size	Sequential identifier	Customer special	Pack type
A		F	5792	13			
A-W / A-F Series	X - 1/4" Flare Omit for 3/8" Flare	F = Flanged W = Welded WZ = Welded High Pressure		In 1/8" Increments	Blank Thru -99	G = Customer Special (Omit for Standard)	B1 = Bulk Pack (Omit for Individual Pack)

## A-F, A-W Oil Separators

F = flanged W = welded	Maximum working Pressure (psig)	Shell diameter (in)	Length (in)	Connection size (odf)	Discharge maximum (cfm)	Pre-charge amount (oz)	Maximum capacity of refrigeration at evaporator temperature (tons/kw)						Model number	Item number
							R-134a / R-450a / R-513a		R-22 / R-407c / R-448a / R-449a		R-404a / R-507			
							-40°F/c	+40°F (4°C)	-40°F/c	+40°F (4°C)	-40°F/c	+40°F (4°C)		
F	450	4	10.5	1/2"	1.49	17	1.0 (3.5)	1.8 (6.2)	1.5 (5.3)	2.0 (7.1)	1.5 (5.3)	2.0 (7.0)	A-F 58824	060877
F	450	6	15	5/8"	3.42	17	3.3 (11.5)	4.5 (15.9)	4.5 (15.9)	5.5 (19.5)	4.0 (14.2)	5.5 (19.0)	A-F 58855	060878
F	450	4	18	7/8"	6.05	17	4.8 (16.8)	6.5 (23.0)	7.0 (24.8)	8.0 (28.3)	6.5 (23.0)	8.5 (30.0)	A-F 58877	060879
F	450	4	21.25	1-1/8"	8.28	17	6.5 (23.0)	8.5 (30.1)	9.0 (31.9)	11.0 (37.2)	8.5 (30.1)	11.0 (38.0)	A-F 58889	060759
F	450	4	21.38	1-3/8"	9.99	17	8.0 (28.3)	11.5 (40.7)	11.5 (40.7)	14.0 (47.8)	10.5 (37.2)	14.0 (49.0)	A-F 589011	060760
F	450	4	21.75	1-5/8"	10.66	17	9.5 (33.6)	13.3 (46.9)	14.0 (49.6)	17.7 (62.0)	14.0 (49.6)	17.0 (60.0)	A-F 589213	060761
F	450	6	29.12	1-5/8"	23.93	21	11.8 (41.6)	16.0 (56.6)	16.0 (56.6)	18.0 (63.7)	17.5 (62.0)	23.0 (81.0)	A-F 579213 <sup>1</sup>	060875
F	450	6	29.31	2-1/8"	30.93	21	18.0 (63.7)	25.6 (89.4)	25.0 (88.5)	30.0 (106.0)	26.0 (92.0)	34.0 (121.0)	A-F 579417 <sup>1</sup>	060876
W	450	4	10.75	1/2"	1.49	17	1.0 (3.5)	1.8 (6.2)	1.5 (5.3)	2.0 (7.1)	1.5 (5.3)	2.0 (7.0)	A-W 55824	060933
W	450	4	13.2	5/8"	3.42	17	3.3 (11.5)	4.5 (15.9)	4.5 (15.9)	5.5 (19.5)	4.0 (14.2)	5.5 (19.0)	A-W 55855	060934
W	450	4	15	7/8"	6.05	17	4.8 (16.8)	6.5 (23.0)	7.0 (24.8)	8.0 (28.3)	6.5 (23.0)	8.5 (30.0)	A-W 55877	060931
W	450	4	16.25	1-1/8"	8.28	17	6.5 (23.0)	8.5 (30.1)	9.0 (31.9)	11.0 (37.2)	8.5 (30.1)	11.0 (38.0)	A-W 55889	060974
W	450	4	19.5	1-3/8"	9.99	17	8.0 (28.3)	11.5 (40.7)	11.5 (40.7)	14.0 (47.8)	10.5 (37.2)	14.0 (49.0)	A-W 559011	060930
W	450	4	19.88	1-5/8"	10.66	17	9.5 (33.6)	13.3 (46.9)	14.0 (49.6)	17.7 (62.0)	14.0 (49.6)	17.0 (60.0)	A-W 559213	060975
W	450	6	15.75	1-3/8"	12.27	20	9.5 (33.4)	13.7 (48.2)	13.0 (45.8)	14.0 (49.8)	11.0 (38.7)	19.0 (66.9)	A-W 569011	060978
W	450	6	19	1-5/8"	14.51	20	11.8 (41.6)	16.0 (56.6)	16.0 (56.6)	18.0 (63.7)	17.5 (62.0)	23.0 (81.0)	A-W 569213	060979
W	450	6	19.5	2-1/8"	21.29	20	18.0 (63.7)	25.6 (89.4)	25.0 (88.5)	30.0 (106.0)	26.0 (92.0)	34.0 (121.0)	A-W 569417	060980

<sup>1</sup> Replaceable Float

A-WZ Oil Separators

F = flanged w = welded	Maximum working pressure (psi)	Shell diameter (in)	Length (in)	Connection size (odf)	Discharge maximum (cfm)	Pre-charge amount (oz)	Maximum capacity of refrigeration at evaporator temperature (tons/kw)								Model number	Item number
							R-134a / R-450a / R-513a		R-22 / R-407c / R-448a / R-449a		R-404a / R-507		R-410a			
							-40°F/c	+40°F (4°C)	-40°F/c	+40°F (4°C)	-40°F/c	+40°F (4°C)	-40°F/c	+40°F (4°C)		
W	600	4	10.88	1/2"	1.49		1.0 (3.5)	1.8 (6.2)	1.5 (5.3)	2.0 (7.1)	1.5 (5.3)	2.0 (7.0)	2.7 (9.0)	3.1 (11.0)	A-XWZ 55824	066680
W	600	4	10.88	1/2"	1.49	17	1.0 (3.5)	1.8 (6.2)	1.5 (5.3)	2.0 (7.1)	1.5 (5.3)	2.0 (7.0)	2.7 (9.0)	3.1 (11.0)	A-WZ 55824	066135
W	600	4	13.31	5/8"	3.42	17	3.3 (11.5)	4.5 (15.9)	4.5 (15.9)	5.5 (19.5)	4.0 (14.2)	5.5 (19.0)	7.4 (26.0)	8.4 (29.0)	A-WZ 55855	066136
W	600	4	15.13	7/8"	6.05	17	4.8 (16.8)	6.5 (23.0)	7.0 (24.8)	8.0 (28.3)	6.5 (23.0)	8.5 (30.0)	11.0 (38.0)	12.0 (43.0)	A-WZ 55877	066137
W	600	4	16.38	1-1/8"	8.28	17	6.5 (23.0)	8.5 (30.1)	9.0 (31.9)	11.0 (37.2)	8.5 (30.1)	11.0 (38.0)	15.0 (52.0)	17.0 (59.0)	A-WZ 55889	066138
W	600	4	19.63	1-3/8"	9.99	17	8.0 (28.3)	11.5 (40.7)	11.5 (40.7)	14.0 (47.8)	10.5 (37.2)	14.0 (49.0)	19.0 (66.0)	21.0 (75.0)	A-WZ 559011	066139
W	680	6	15.5	1-1/8"	10.05	25	7.7 (27.0)	9.4 (33.0)	11.1 (39.0)	13.3 (46.6)	10.6 (37.3)	14.0 (49.1)	18.2 (63.9)	20.6 (72.5)	A-WZ 56909	066140
W	680	6	15.75	1-3/8"	12.27	25	9.4 (33.0)	11.5 (40.3)	13.5 (47.6)	16.2 (56.9)	12.9 (45.5)	17.0 (60.0)	22.2 (77.9)	25.1 (88.4)	A-WZ 569011	066141
W	680	6	18.5	1-5/8"	14.51	25	11.1 (39.0)	13.6 (47.7)	16.0 (56.3)	19.1 (67.3)	15.3 (53.8)	20.2 (70.9)	27.4 (96.4)	30.9 (108.8)	A-WZ 569213	066143

A-WC / A-FC series parts list

Description	Model number	Item number
Oil Separator Flange Gasket	Oil separator kit	065849
Flange with Integral Float Assembly and Flange Gasket, Repairs A-FC, AF, AC and R Series S1900 Standard and 5200 Helical Oil Separators	Float repair kit	065847



Detailed product drawings



A-FL 0401704S04S-921

# A-FL Ultra High Performance Coalescent Oil Separator

The A-FL Coalescent Oil Separator provides unmatched efficiency and performance for a wide variety of refrigeration air-conditioning systems where oil migration is a concern. The Coalescent design employs a glass fiber filter cartridge for optimal separation and filtration and incorporates a built-in oil reservoir to reduce the need for additional piping and external components. This design enables the Coalescent Oil Separator to maintain stable, optimal performance at low system load levels, consistently preventing oil migration and improving system energy efficiency across all conditions.

## Features

- Internal filter cartridge provides optimal oil separation and 0.3 micron filtration
- Accessible bolted flange construction with replaceable filter
- Corrosion resistant epoxy powder paint
- High efficiency (99%) coalescent separation and contaminant removal

## Specifications

Maximum working pressure ..... 650 psig (45 bar)  
UL/CUL file number ..... SA8547

Model number nomenclature - Example: A-FL 0401704S04S

Series	Style	Coalescent	Shell diameter	Length	Inlet connection size	Inlet connection type	Outlet connection size	Outlet connection type	Sequential identifier	Customer special	Pack type
A	F	L	040	17	04	S	04	S			
A-FL Series	F = Flanged W = Welded	Coalescent Design	Diameter in Inches (XX.X) 040 = 4.0"	In Inches (XX)	In 1/8" Increments	S=ODF	In 1/8" Increments	S=ODF	Blank Thru -999	G = Customer Special (Omit for Standard)	B1=Bulk Pack (Omit for Individual Pack)

## A-FL Coalescent Oil Separators

Diameter (in)	Connection size (odf)	Length (in)	Oil connection	Maximum capacity of refrigeration at evaporator temperature - tons (kw)								Oil pre-charge Amount - liters (oz)	Model number	Item number
				R-22 / R-407C / R-444B / R-448A / R-449A		R-134A / R-450A / R-513A / R-1234YF / R-1234ZE		R-404A / R-507A / R-452A / R-407A / R-407F		R-410A / R-32				
				-40°F/c	+40°F (4°C)	-40°F/c	+40°F (4°C)	-40°F/c	+40°F (4°C)	-40°F/c	+40°F (4°C)			
4	1/2"	17.0	1/4" SAE	1.1 (3.8)	6.3 (22.1)	0.6 (2.1)	4.1 (14.4)	1.0 (3.5)	6.5 (22.8)	1.7 (5.9)	9.2 (32.4)	1.7 (58)	A-FL 0401704S04S-921	096869
4	5/8"	19.5	1/4" SAE	1.6 (5.6)	8.9 (31.3)	0.9 (3.2)	5.8 (20.4)	1.5 (5.3)	9.1 (32.1)	2.4 (8.6)	12.9 (45.7)	2.1 (71)	A-FL 0402005S05S-922	1837021
4	7/8"	19.5	1/4" SAE	2.2 (7.7)	12.4 (43.5)	1.2 (4.2)	8.1 (28.4)	2.1 (7.3)	12.7 (44.7)	3.4 (11.9)	18.1 (63.6)	2.1 (71)	A-FL 0402007S07S-923	1837013

## A-FL series parts list

Description	For use with A-FL model	Model number	Item number
Filter Replacement Kit for Coalescent Oil Separator - 2.5" Filter Assembly	1/2" Connection Models (-921)	A-FL FL1	1818867
Filter Replacement Kit for Coalescent Oil Separator - 4.75" Filter Assembly	5/8" & 7/8" Connection Models (-922 & -923)	A-FL FL2	1836977
Replacement Flange Gasket for A-FL Coalescent Oil Separator	All Models	A-FL GASKET1	1843798



AOR-2

# AOR Series Oil Reservoirs

The AOR oil reservoir is a holding vessel for stand-by oil necessary for the operation of commercial refrigeration systems. It is a direct replacement of popular competitive models.

## Features

- Two sight glasses with floating ball indicators - 2 gallon model
- Three sight glasses with floating ball indicators - 4 gallon model
- 3/8" flare roto-lock valves on top and bottom
- Corrosion resistant epoxy powder paint finish
- Standard mounting stud 3/8 x 16 TPI

## Specifications

Maximum working pressure .....450 psi (31 bar)  
 UL/CUL file number.....SA8547

### Model number nomenclature - Example: AOR 3

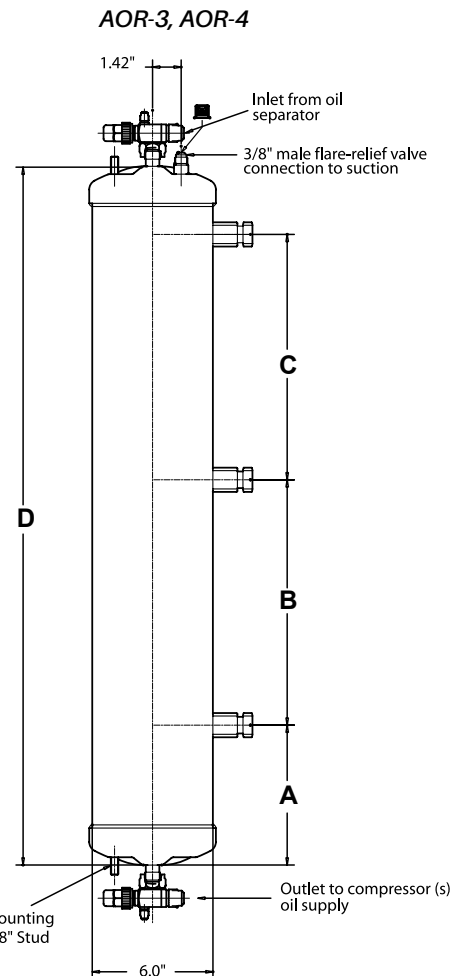
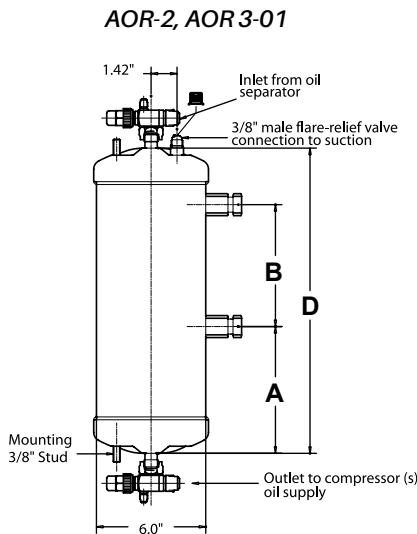
Series	Gallons	Sequential identifier	Customer special	Pack type
AOR	3			
AOR Series		Blank Thru -99	G = Customer Special (Omit for Standard)	B1 = Bulk Pack (Omit for Individual Pack)

### AOR Oil Reservoirs

Total volume (gals)	A level volume (gals)	B level volume (gals)	C level volume (gals)	A (In)	B (In)	C (In)	D (In)	Sight glass	Model number	Item number
2	3/4	1-1/2	—	7	6.7	—	16.75	2	AOR 2	64950
3	2/3	1-2/3	2-2/3	6.5	9	9	28.25	3	AOR 3	65981
4	2/3	2	3-1/3	7	12	12	34.75	3	AOR 4	64951

### AOR series parts list

Description	Model number	Item number
AOR Oil Reservoirs Mounting Kit w/ Mounting Brackets, Self-Tapping Bolts & Mounting Stud Nuts	KD-40014	066002





AOF 023S



AOFD 553



AOF 303

# AOF / AOFD Series High Efficiency Oil Filters / Driers

The AOF is designed to protect the compressor from dirt and all solid contaminants including metallic magnetic particles. It is ideal for burnout/clean-up situations. Select models contain desiccant for moisture removal.

## Features

- Compatible with all oils
- Take-apart model features quick change filter cartridge
- Corrosion resistant epoxy powder paint finish
- 100% efficient to 4 micron particles; 99% efficient to 3 micron particles
- Take-apart model 3/8 ODF, Hermetic model 3/8" SAE Connections
- High debris capacity with low pressure drop
- AOFD contains desiccant for moisture removal

## Specifications

Maximum working pressure ..... Hermetic 680 psi (47 bar)  
 ..... Take-apart 480 psi (33 bar)  
 UL/CUL file number.....SA7175

### Model number nomenclature - Example: AOFD 553

Series	Desiccant	Unique identifier	Connection size	Connection style	Sequential identifier	Customer special	Pack type
AOF	D	55	3				
High Efficiency Oil Filter	D = Desiccant (Omit for No Desiccant)		In 1/8" Increments	S = ODF (Omit for SAE)	Blank Thru -99	G = Customer Special (Omit for Standard)	B1 = Bulk Pack (Omit for Individual Pack)

### AOF High Efficiency Oil Filter

Type	Desiccant	Connection size	Connection type	Access valve	Lay-in (in)	Diameter (in)	Model number	Item number
Hermetic	No	3/8"	SAE	No	9.63	3.06	AOF 303	064952
Take-Apart*	No	3/8"	ODF	Single	7.38	2.5	AOF 023S	062784
Filter Cartridge	—	—	—	—	—	—	F 023	064799
Hermetic	Yes	3/8"	SAE	Dual	9.62	3.17	AOFD 553	062829

\* Filter Cartridge not included

### AOFD water capacity table

Refrigerant	Drops @ 125 f
R-22	497
R-134a	518
R-404A	518
R-407C, R-410A	435
R-448A / R-449A	430
R-450A / R-513	480
R-744	563



OMB D120S

# OMB / OMC Series Oil Management Control

The OMB/C prevents compressor burnout and system downtime by maintaining a proper compressor crankcase oil level. Ideal for all brands of semi-hermetic compressors and recommended for Copeland Scroll.

## Features

- Compressor lockout feature alerts repeated low oil for early system diagnosis and resolution
- Easy monitoring with visual alarm and multi-color status lights
- Hall-effect sensing technology unlike optical sensors, eliminates false detection of possible oil foaming
- System debris retention magnet for reliable control
- Oil level float ball in sight glass allows quick visual indication
- Simple to install with adapters available for various compressor types
- OMC Series offers optional side sight glass that provides oil level view from multiple directions, multiple voltage ratings to eliminate need for stepdown transformer and a self-contained electrical enclosure with conduit connections for field service wiring

## OMB/C Series Oil Management Control specifications

Specifications	OMB	OMC	OMC CO <sub>2</sub>
Maximum Working Pressure (MWP)	870 psig (60 bar)		1885 psig (130 bar)
Solenoid min/max OPD	0/350 psig (0/24 bar)		0/1450 psig (0/100 bar)
Supply Voltage	24V 50/60 Hz	120V or 220-240V, 50/60 Hz	24, 120V OR 220-240V, 50/60 Hz
Solenoid Coil	EMF		
Current Consumption	0.6 Amp (24V)	0.15 Amp (120V), 0.07 Amp (220-240V)	0.6 Amp (24V) 0.15 Amp (120V) 0.07 Amp (220-240V)
Time Delay for Low Level Signal	10 Seconds		
Time Delay After Setpoint Recovery	5 Seconds		
Alarm Delay Time (Including Alarm Contact)	120 Seconds		
Alarm Switch	SPDT		
Alarm Contact Rating	10A @ 120VAC 50/60 Hz, 5A @ 250VAC 50/60 Hz, 3A @ 30VDC		
Refrigerant Compatibility	Class A1 (incl. subcritical CO <sub>2</sub> ); Class A2L R-1234yf, R-1234ze, R-32, R-452B, R-454A, R-454B, R-454C, R-455A		Transcritical CO <sub>2</sub>
Oil Temperature	-40°F/C to 180°F (82°C) Maximum		
Ambient Temperature - Storage	-40°F/C to 120°F (49°C) Maximum		
Ambient Temperature - Intermittent Duty	-40°F/C to 120°F (49°C) Maximum		
Oil Supply Fitting	1/4" Male SAE		
	(Brass)		
Agency	UL/CUL File Number MP604		

*Model number nomenclature - Example: OMC D120CO2S*

Series	Configuration	Coil voltage	Application	Strainer
OMB	D	120	CO2	S
OMB = Oil Management Control	JB = Junction Box MO = Grommet with Leads	24 = 24V 50/60 Hz	K5 = For Copeland K5 Compressor with Adapter (Omit for Standard)	S = Strainer (Omit for No Strainer)
OMB = Oil Management Control Multi-Voltage	D = Dual Sight Glass = Single Sight Glass (OEM) S	24 = 24V 50/60Hz 120 = 120V 50/60 Hz 240 = 240V 50/60 Hz	CO2 = Transcritical CO2 K5 = For Copeland K5 Compressor with Adapter (Omit for Standard)	S = Strainer (Omit for No Strainer)

NOTE: It is recommended that an oil filter be installed on the oil inlet line to further protect the system from contaminants even when the oil management control contains an inlet strainer.

**OMB/C Series Oil Management Controls**

Coil voltage	Application	Configuration	Inlet strainer	Model number	Item number
24 VAC, 50/60 Hz	Standard	Junction Box	No	OMB JB24	065365
24 VAC, 50/60 Hz	Standard	Grommet With Leads	No	OMB MO24	065366
120 VAC, 50/60 Hz	Standard	Dual Sight Glass	Yes	OMB D120S	096806
220-240 VAC, 50/60 Hz	Standard	Dual Sight Glass	Yes	OMB D240S	096807
24 VAC, 50/60 Hz	Transcritical CO2	Dual Sight Glass	Yes	OMB D24CO2S	1815412
120 VAC, 50/60 Hz	Transcritical CO2	Dual Sight Glass	Yes	OMB D120CO2S	1815404
220-240 VAC, 50/60 Hz	Transcritical CO2	Dual Sight Glass	Yes	OMB D240CO2S	OMB D240CO2S

NOTE: For aftermarket replacement, models with INLET STRAINER replace the previous models that had no strainer.

**OM series parts list**

Description	Model number	Item number
OM Strainer Assembly 1/4" Inlet Filter Screen	X-11176-7	048638
AMI / OM Sight Glass O-Rings 50 Count	PS-1525-2	020877
OM Mounting O-Rings (3 Pieces)	KS-30368-1	064812



See oil controls  
adapter page for  
available adapters



W-OLC-2

# W-OLC Series Mechanical Oil Level Control

The W-OLC controls the oil level in the compressor crankcase with a float operated valve and keeps the oil level at the compressor manufacturer recommended level.

## Features

- Corrosion resistant epoxy powder paint finish
- Universal slotted holes for faster installation
- Hard stop design to prevent damage during adjustments

## Specifications

Maximum working pressure ..... 450 psi (31 bar)  
 Maximum operating pressure differential..... 90 psi (6 bar)  
 UL/CUL file number..... SA8547  
 Canadian CRN..... 0E21791.513467890YTN

### Model number nomenclature - Example: W-OLC-2-4

Series	Sight glass	Equalizer	Sequential identifier	Customer special	Pack type
W-OLC	-2				
W-OLC Series	2 = 1/2 Sight Glass 4 = 1/4 Sight Glass 2-4 = 1/4 to 1/2 level (adjustable)	N = No Equalizer Line E = 2 Equalizer Lines (Omit for 1 Equalizer Line)	Blank Thru -99	G = Customer Special  (Omit for Standard)	B1 = Bulk Pack  (Omit for Individual Pack)

### W-OLC series oil management control

Sight glass level	Model number	Item number
1/2 Sight Glass	W-OLC-2	064953
1/4 Sight Glass	W-OLC-4	064954
1/4 to 1/2 level (adjustable)	W-OLC-2-4	065170
OM Mounting O-Rings (3 Pieces)	KS-30368-1	064812



See oil controls adapter page for available adapters

Instruction sheet

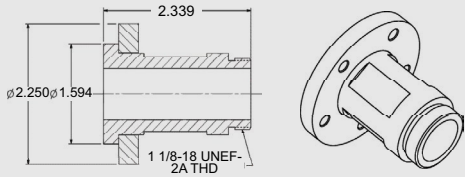
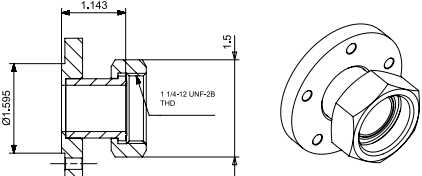
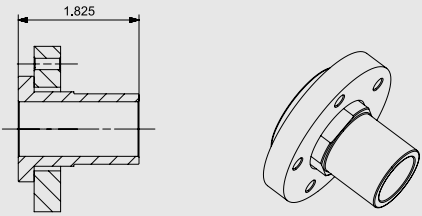


# Oil Management Control Adapters

Compatible oil management control	Description	Model number	Item number	Adapter torque to compressor	Drawing
OMB/OMC	Screw Adapter 3/4" x 14 NPTF	KS-30376	065668	30 - 40 ft - lbs	<p>1.825 3/4" NPT ADDITIONAL FLANGE RING INCLUDED</p>
OMB/OMC	Screw Adapter 1-1/8" x 18 UNEF-2A THD	KS-30398	066692	37 - 44 ft-lbs	<p>2.339 2.250 1.594 1 1/8-18 UNEF-2A THD ADDITIONAL FLANGE RING INCLUDED</p>
OMB/OMC	Screw Adapter, Female Nut 1-3/4" x 12 UNF - 2B THD	KS-30385	066078	30 - 40 ft - lbs	<p>2.000 HEX 3/4" NPT 1 3/4-12 UNF-2B THD ADDITIONAL FLANGE RING INCLUDED</p>
OMB/OMC	Rotalock Adapter 1-1/4" x 12 UNF-2B THD Includes injection tube for K5 compressors	KS-30394-2	066650	80 ft - lbs	<p>1.143 1.500 1 1/4-12 UNF-2B THD Ø 1.595 OIL INJECTION TUBE INCLUDED</p>
OMB/OMC	Rotalock Adapter 1-1/4" x 12 UNF-2B THD Includes injection tube for K5 compressors	KS-30394-1	066652	80 ft - lbs	<p>2.057 1.500 HEX 1 1/4-12 UNF-2B THD Ø 1.595 OIL INJECTION TUBE INCLUDED</p>
OMB/OMC/W-OLC	Adapter for Copeland Semi-Hermetic	KS-30348	063521	120 in - lbs	<p>1.65 2.36 ADDITIONAL FLANGE RING INCLUDED</p>
OMB/OMC	Screw Adapter 1-1/2" x 18 UNEF - 2A THD	KS-30381	065982	30 - 40 ft - lbs	<p>1 1/2-18 UNEF-2A THD 3/4" NPT ADDITIONAL FLANGE RING INCLUDED</p>

Install oil control to adapter flange (1/4" x 20 UNC x 1" hex bolt) at 120 in-lbs

Oil Management Control Adapters (continued)

Compatible oil management control	Description	Model number	Item number	Adapter torque to compressor	Drawing
OMC CO2	Screw Adapter 1 1/8" x 18 UNEF-2A THD 5 Hole Flange	KS-30399	066910	37 - 44 ft-lbs	
OMC CO2	Rotolock Adapter 1-1/4" x 12 UNF-2B THD 5 Hole Flange	KS-30400	1961102	80 ft - lbs	
OMC CO2	Screw Adapter 3/4" x 14 NPTF 5 Hole Flange	KS-30406	1968638	30 - 40 ft - lbs	

Install oil control to adapter flange (1/4" x 20 UNC x 1" hex bolt) at 120 in-lbs

# DCFM Charge Calculations

**Example:**

System: .....9.5 tons, R-404A  
 Evaporator temperature: ..... 25°F  
 Condensing temperature: ..... 115°F

**Example:**

$.618 \frac{\text{DCFM}}{\text{ton}} \times 9.5 \text{ ton} = 5.871 \text{ CFM}$   
 Oil Separator selected: AF-58877  
 DCFM = Cubic feet per minute

In the table for R-404A, search for the value corresponding to the temperatures of evaporation and condensation. This is the DCFM/ton factor. At 25°F evaporator temperature and 115°F condensing temperature, the DCFM/ton is .618. Multiply this by the system tonnage. Use the resulting value to select the proper oil separator. DCFM values can be found on the oil separator catalog pages. Select an oil separator with a capacity greater than or equal to the value obtained.

NOTE: The connection of the separator must never be less than the diameter of the discharge line.

		R-22								
		Oil separator dcfm / ton factor								
		Condensing temperature (°f)								
		130	125	120	115	110	105	100	95	90
Evaporating temperature (°f)	-40	0.633	0.659	0.687	0.717	0.750	0.786	0.824	0.865	0.910
	-35	0.626	0.652	0.680	0.710	0.743	0.778	0.816	0.857	0.902
	-30	0.619	0.645	0.673	0.704	0.736	0.771	0.809	0.850	0.894
	-25	0.613	0.639	0.667	0.697	0.729	0.764	0.802	0.843	0.887
	-20	0.607	0.633	0.660	0.690	0.723	0.758	0.795	0.836	0.880
	-15	0.601	0.626	0.654	0.684	0.716	0.751	0.788	0.829	0.873
	-10	0.595	0.621	0.648	0.678	0.710	0.745	0.782	0.822	0.866
	-5	0.589	0.615	0.642	0.672	0.704	0.739	0.776	0.816	0.859
	0	0.584	0.609	0.637	0.666	0.698	0.733	0.770	0.809	0.853
	5	0.578	0.604	0.631	0.661	0.693	0.727	0.764	0.803	0.846
	10	0.573	0.599	0.626	0.656	0.687	0.721	0.758	0.797	0.840
	15	0.568	0.594	0.621	0.650	0.682	0.716	0.752	0.792	0.834
	20	0.564	0.589	0.616	0.645	0.677	0.710	0.747	0.786	0.828
	25	0.559	0.584	0.611	0.640	0.672	0.705	0.742	0.781	0.823
	30	0.555	0.580	0.607	0.636	0.667	0.700	0.736	0.775	0.817
	35	0.550	0.575	0.602	0.631	0.662	0.696	0.732	0.770	0.812
	40	0.546	0.571	0.598	0.627	0.658	0.691	0.727	0.765	0.807
45	0.542	0.567	0.594	0.623	0.653	0.687	0.722	0.761	0.802	

		R-134a								
		Oil separator dcfm / ton factor								
		Condensing temperature (°f)								
		130	125	120	115	110	105	100	95	90
Evaporating temperature (°f)	-40	0.998	1.032	1.070	1.113	1.159	1.210	1.266	1.328	1.395
	-35	0.980	1.015	1.053	1.095	1.141	1.192	1.248	1.310	1.377
	-30	0.963	0.998	1.036	1.078	1.124	1.175	1.231	1.292	1.359
	-25	0.946	0.981	1.019	1.062	1.108	1.158	1.214	1.275	1.341
	-20	0.930	0.965	1.004	1.046	1.092	1.142	1.197	1.258	1.324
	-15	0.915	0.950	0.988	1.030	1.076	1.126	1.181	1.241	1.307
	-10	0.900	0.935	0.973	1.015	1.061	1.111	1.166	1.226	1.291
	-5	0.886	0.921	0.959	1.001	1.047	1.096	1.151	1.210	1.275
	0	0.872	0.907	0.945	0.987	1.032	1.082	1.136	1.195	1.260
	5	0.859	0.894	0.932	0.973	1.019	1.068	1.122	1.181	1.245
	10	0.846	0.881	0.919	0.960	1.006	1.055	1.108	1.167	1.231
	15	0.834	0.869	0.906	0.948	0.993	1.042	1.095	1.153	1.217
	20	0.822	0.857	0.894	0.936	0.980	1.029	1.082	1.140	1.203
	25	0.810	0.845	0.883	0.924	0.968	1.017	1.070	1.127	1.190
	30	0.799	0.834	0.871	0.912	0.957	1.005	1.057	1.115	1.177
	35	0.789	0.823	0.861	0.901	0.945	0.993	1.046	1.103	1.165
	40	0.778	0.813	0.850	0.890	0.934	0.982	1.034	1.091	1.153
45	0.768	0.803	0.840	0.880	0.924	0.971	1.023	1.080	1.141	

		R-404A								
		Oil separator dcfm / ton factor								
		Condensing temperature (°f)								
		130	125	120	115	110	105	100	95	90
Evaporating temperature (°f)	-40	0.751	0.759	0.771	0.787	0.807	0.830	0.856	0.885	0.918
	-35	0.731	0.740	0.753	0.770	0.790	0.814	0.840	0.870	0.903
	-30	0.712	0.722	0.736	0.754	0.775	0.798	0.825	0.855	0.888
	-25	0.694	0.705	0.720	0.738	0.760	0.784	0.811	0.841	0.874
	-20	0.677	0.689	0.705	0.724	0.745	0.770	0.797	0.827	0.860
	-15	0.661	0.674	0.691	0.710	0.731	0.756	0.783	0.814	0.847
	-10	0.646	0.660	0.677	0.696	0.718	0.743	0.771	0.801	0.834
	-5	0.632	0.646	0.664	0.683	0.706	0.731	0.758	0.789	0.822
	0	0.618	0.633	0.651	0.671	0.694	0.719	0.747	0.777	0.810
	5	0.605	0.621	0.639	0.659	0.682	0.708	0.735	0.766	0.799
	10	0.593	0.609	0.628	0.648	0.671	0.697	0.725	0.755	0.788
	15	0.581	0.598	0.617	0.638	0.661	0.686	0.714	0.745	0.778
	20	0.570	0.587	0.606	0.628	0.651	0.676	0.704	0.735	0.768
	25	0.560	0.577	0.596	0.618	0.641	0.667	0.695	0.725	0.758
	30	0.550	0.568	0.587	0.609	0.632	0.658	0.686	0.716	0.749
	35	0.540	0.558	0.578	0.600	0.623	0.649	0.677	0.707	0.740
	40	0.532	0.550	0.570	0.591	0.615	0.641	0.669	0.699	0.732
45	0.523	0.542	0.562	0.583	0.607	0.633	0.661	0.691	0.723	

		R-407C								
		Oil separator dcfm / ton factor								
		Condensing temperature (°f)								
		130	125	120	115	110	105	100	95	90
Evaporating temperature (°f)	-40	0.669	0.695	0.722	0.753	0.786	0.822	0.862	0.905	0.952
	-35	0.659	0.684	0.712	0.743	0.776	0.812	0.851	0.894	0.941
	-30	0.649	0.674	0.702	0.733	0.766	0.802	0.841	0.884	0.930
	-25	0.640	0.665	0.693	0.723	0.756	0.792	0.831	0.874	0.920
	-20	0.630	0.656	0.684	0.714	0.747	0.782	0.821	0.864	0.910
	-15	0.621	0.647	0.675	0.705	0.738	0.773	0.812	0.854	0.900
	-10	0.613	0.638	0.666	0.696	0.729	0.764	0.803	0.845	0.891
	-5	0.605	0.630	0.658	0.688	0.720	0.756	0.794	0.836	0.882
	0	0.597	0.622	0.650	0.680	0.712	0.748	0.786	0.828	0.873
	5	0.589	0.614	0.642	0.672	0.704	0.740	0.778	0.819	0.864
	10	0.582	0.607	0.635	0.664	0.697	0.732	0.770	0.811	0.856
	15	0.575	0.600	0.627	0.657	0.689	0.724	0.762	0.803	0.848
	20	0.568	0.593	0.620	0.650	0.682	0.717	0.755	0.796	0.840
	25	0.561	0.586	0.614	0.643	0.675	0.710	0.748	0.788	0.833
	30	0.555	0.580	0.607	0.637	0.669	0.703	0.741	0.781	0.825
	35	0.549	0.574	0.601	0.631	0.662	0.697	0.734	0.774	0.818
	40	0.543	0.568	0.595	0.625	0.656	0.691	0.728	0.768	0.812
45	0.537	0.563	0.590	0.619	0.650	0.685	0.722	0.762	0.805	

		R-410A								
		Oil separator dcfm / ton factor								
		Condensing temperature (°f)								
		130	125	120	115	110	105	100	95	90
Evaporating temperature (°f)	-40	0.397	0.415	0.433	0.453	0.475	0.498	0.523	0.549	0.578
	-35	0.392	0.410	0.429	0.449	0.470	0.493	0.518	0.544	0.573
	-30	0.388	0.405	0.424	0.444	0.465	0.488	0.513	0.539	0.568
	-25	0.383	0.401	0.419	0.439	0.461	0.484	0.508	0.535	0.563
	-20	0.379	0.397	0.415	0.435	0.456	0.479	0.504	0.530	0.559
	-15	0.375	0.392	0.411	0.431	0.452	0.475	0.500	0.526	0.554
	-10	0.371	0.388	0.407	0.427	0.448	0.471	0.495	0.522	0.550
	-5	0.367	0.385	0.403	0.423	0.444	0.467	0.491	0.518	0.546
	0	0.364	0.381	0.400	0.420	0.441	0.463	0.488	0.514	0.542
	5	0.360	0.378	0.396	0.416	0.437	0.460	0.484	0.510	0.538
	10	0.357	0.374	0.393	0.413	0.434	0.456	0.480	0.506	0.534
	15	0.354	0.371	0.390	0.410	0.431	0.453	0.477	0.503	0.531
	20	0.351	0.368	0.387	0.406	0.427	0.450	0.474	0.500	0.527
	25	0.348	0.365	0.384	0.404	0.425	0.447	0.471	0.496	0.524
	30	0.345	0.363	0.381	0.401	0.422	0.444	0.468	0.494	0.521
	35	0.343	0.360	0.379	0.398	0.419	0.441	0.465	0.491	0.518
	40	0.340	0.358	0.376	0.396	0.417	0.439	0.463	0.488	0.516
45	0.338	0.356	0.374	0.394	0.414	0.437	0.460	0.486	0.513	

		R-448A								
		Oil separator dcfm / ton factor								
		Condensing temperature (°f)								
		130	125	120	115	110	105	100	95	90
Evaporating temperature (°f)	-40	0.662	0.684	0.709	0.736	0.766	0.799	0.835	0.875	0.917
	-35	0.651	0.673	0.698	0.725	0.756	0.788	0.824	0.863	0.906
	-30	0.640	0.663	0.688	0.715	0.745	0.778	0.814	0.853	0.895
	-25	0.630	0.652	0.677	0.705	0.735	0.768	0.803	0.842	0.885
	-20	0.620	0.642	0.668	0.695	0.725	0.758	0.793	0.832	0.874
	-15	0.610	0.633	0.658	0.686	0.716	0.748	0.784	0.822	0.864
	-10	0.601	0.624	0.649	0.677	0.706	0.739	0.774	0.813	0.855
	-5	0.592	0.615	0.640	0.668	0.698	0.730	0.765	0.804	0.845
	0	0.583	0.607	0.632	0.659	0.689	0.722	0.757	0.795	0.836
	5	0.575	0.599	0.624	0.651	0.681	0.713	0.748	0.786	0.828
	10	0.568	0.591	0.616	0.643	0.673	0.705	0.740	0.778	0.819
	15	0.560	0.583	0.609	0.636	0.666	0.698	0.732	0.770	0.811
	20	0.553	0.576	0.601	0.629	0.658	0.690	0.725	0.762	0.803
	25	0.546	0.569	0.594	0.622	0.651	0.683	0.718	0.755	0.796
	30	0.539	0.563	0.588	0.615	0.644	0.676	0.711	0.748	0.788
	35	0.533	0.556	0.581	0.609	0.638	0.670	0.704	0.741	0.781
	40	0.527	0.550	0.575	0.602	0.632	0.663	0.697	0.734	0.774
45	0.521	0.544	0.569	0.596	0.626	0.657	0.691	0.728	0.768	

		R-449A								
		Oil separator dcfm / ton factor								
		Condensing temperature (°f)								
		130	125	120	115	110	105	100	95	90
Evaporating temperature (°f)	-40	0.622	0.648	0.676	0.707	0.739	0.774	0.812	0.853	0.898
	-35	0.614	0.640	0.668	0.698	0.730	0.765	0.803	0.844	0.888
	-30	0.606	0.632	0.659	0.689	0.722	0.757	0.794	0.835	0.879
	-25	0.598	0.624	0.651	0.681	0.713	0.748	0.785	0.826	0.869
	-20	0.590	0.616	0.644	0.673	0.705	0.740	0.777	0.817	0.860
	-15	0.583	0.608	0.636	0.666	0.697	0.732	0.769	0.808	0.851
	-10	0.576	0.601	0.629	0.658	0.690	0.724	0.760	0.800	0.843
	-5	0.569	0.594	0.621	0.651	0.682	0.716	0.753	0.792	0.835
	0	0.562	0.587	0.615	0.644	0.675	0.709	0.745	0.784	0.827
	5	0.556	0.581	0.608	0.637	0.668	0.702	0.738	0.777	0.819
	10	0.549	0.575	0.601	0.630	0.661	0.695	0.731	0.769	0.811
	15	0.543	0.568	0.595	0.624	0.655	0.688	0.724	0.762	0.804
	20	0.538	0.563	0.589	0.618	0.648	0.682	0.717	0.755	0.797
	25	0.532	0.557	0.583	0.612	0.642	0.675	0.711	0.749	0.790
	30	0.527	0.551	0.578	0.606	0.636	0.669	0.704	0.742	0.783
	35	0.521	0.546	0.572	0.600	0.631	0.663	0.698	0.736	0.777
	40	0.516	0.541	0.567	0.595	0.625	0.658	0.692	0.730	0.771
45	0.512	0.536	0.562	0.590	0.620	0.652	0.687	0.724	0.765	

		R-507A								
		Oil separator dcfm / ton factor								
		Condensing temperature (°f)								
		130	125	120	115	110	105	100	95	90
Evaporating temperature (°f)	-40	0.747	0.753	0.763	0.777	0.795	0.816	0.841	0.869	0.900
	-35	0.726	0.733	0.745	0.760	0.778	0.800	0.825	0.853	0.884
	-30	0.707	0.715	0.727	0.743	0.762	0.784	0.810	0.838	0.869
	-25	0.688	0.698	0.711	0.727	0.747	0.770	0.795	0.824	0.855
	-20	0.671	0.681	0.695	0.712	0.733	0.755	0.781	0.810	0.841
	-15	0.654	0.666	0.680	0.698	0.719	0.742	0.768	0.797	0.828
	-10	0.638	0.651	0.666	0.685	0.705	0.729	0.755	0.784	0.816
	-5	0.624	0.637	0.653	0.672	0.693	0.716	0.743	0.772	0.803
	0	0.610	0.624	0.640	0.659	0.681	0.705	0.731	0.760	0.792
	5	0.596	0.611	0.628	0.647	0.669	0.693	0.720	0.749	0.780
	10	0.584	0.599	0.617	0.636	0.658	0.682	0.709	0.738	0.770
	15	0.572	0.588	0.606	0.625	0.647	0.672	0.698	0.727	0.759
	20	0.561	0.577	0.595	0.615	0.637	0.662	0.688	0.718	0.749
	25	0.550	0.567	0.585	0.605	0.628	0.652	0.679	0.708	0.740
	30	0.540	0.557	0.576	0.596	0.619	0.643	0.670	0.699	0.731
	35	0.531	0.548	0.567	0.587	0.610	0.634	0.661	0.690	0.722
	40	0.528	0.545	0.564	0.585	0.607	0.632	0.659	0.688	0.719
45	0.513	0.531	0.550	0.571	0.594	0.618	0.645	0.674	0.705	



16E09-101

# 16E Digital Refrigeration Temperature Control

Superior temperature control and accuracy for both refrigeration and heating applications.

## Features

- Multiple input voltages (24/120/208/240 volts) with no common wire required on electrical loads greater than 2.5 amps uninterrupted
- Reduces inventory - replaces most competitive mechanical and electronic refrigeration controls
- Electronic temperature accuracy/digital display
- Alarm output (with selectable delay - up to 99 minutes)
- Adjustable anti-short cycle delay, Set-point locking function
- Multiple sensor option can be used with 1 or 4 sensors

## Specifications

Voltage.....	24, 120, 208, 240 VAC
Full load amps.....	16A at 120 VAC, 9.2A at 208 VAC, 8A at 240 VAC
Non-inductive amps.....	16 Amps
Minimum load.....	1 Amp @ 24 VAC
Set-point range.....	-40°F to 200°F (-40° to 104°C)
Differential range.....	1° to 30°F (1° to 30°C)
Switch action.....	SPDT
Dimensions.....	6.75"H X 3.00"W X 2.57"D
UL/CUL file number.....	E12615

## 16E Electronic Refrigeration Temperature Control

Range	Differential	Switch action	Model number	Item number
-40 to 220°F	1 to 30°F	SPDT	16E09-101	16E09-101

## Parts and accessories

Description	Model number	Item number
Replacement 7.5-ft NTC remote sensor	F136-0114	F136-011400



See oil controls adapter page for available adapters

Instruction sheet



# 1600 Series Refrigeration Temperature Controls

Provide positive control of refrigeration applications where remote control is desired.



1609-90

## Features

- Hydraulic action element
- Dustproof steel case with top and bottom knockouts
- Temperature dial graduated in °F and °C and can be adjusted through cover
- High electrical ratings allow operation of most equipment without use of relays or motor starters
- Model 1609-90 for use in zoning systems where all thermostats control a common compressor and a separate solenoid refrigerant valve in each zone. 16A60 manual reset freeze protection

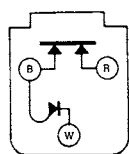
## Specifications

Bulb mounting..... Clamp included with all models except 1609-90  
 Finish ..... Grey  
 Dimensions ..... 5.38"H X 2.31"W X 2.57"D  
 Agency ..... UL/CUL

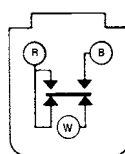
### 1600 Series Refrigeration Temperature Controls

Range	Differential	Capillary length	Bulb size	Switch action	Motor rating (full load) 120 vac	Motor rating (full load) 240 vac	Model number	Item number
-20 to 50°F (-29 to 10°C)	Adj. 3 to 25°F (2 to 14°C)	8 ft.	5-3/4" X 3/8"	Close on Rise	7.4A	3.7A	1609-90	16 09 090S1
-30 to 90°F (-34 to 32°C)	Adj. 3.5 to 40°F (2 to 22°C)	5 ft.	5-3/16" X 3/8"	Close on Rise	16.0A	8.0A	1609-101	16 09 101S1
-30 to 90°F (-34 to 32°C)	Adj. 3.5 to 40°F (2 to 22°C)	10 ft.	5-3/16" X 3/8"	Close on Rise	16.0A	8.0A	1609-103	16 09 103S1
-30 to 90°F (-34 to 32°C)	Adj. 3.5 to 40°F (2 to 22°C)	20 ft.	5-3/16" X 3/8"	Close on Rise	16.0A	8.0A	1609-104	16 09 104S1
-30 to 90°F (-34 to 32°C)	Adj. 3.5 to 40°F (2 to 22°C)	5 ft.	5-3/16" X 3/8"	Close on Rise	16.0A	8.0A	1609-105 ①	16 09 105S1
-30 to 90°F (-34 to 32°C)	Adj. 4.5 to 40°F (2.5 to 22°C)	8 ft.	5-3/16" X 3/8"	SPDT	7.4A	3.7A	1687-9	16 87 009S1
-30 to 50°F (-34 to 10°C)	Manual Reset	10 ft.	5-3/16" X 3/8"	Open on Fall	7.4A	3.7A	16A60-9	16A60 009S1

① Knob adjustment.



HH2C CONTACT STRUCTURE  
 HH2C Rated Controls  
 SWITCH ACTION  
 Double pole, single throw.  
 B terminal is common.  
 B-R and B-W contacts both close on a rise of temperature.



SPDT CONTACT STRUCTURE  
 SPDT Rated Controls  
 SWITCH ACTION  
 R-B Open on Rise  
 R-W Close on Rise



201-8

# 200 Series Refrigeration Temperature Controls

Designed for use in garages, factories, warehouses and similar commercial and industrial installations.

## Features

- Handles inductive and non-inductive loads
- No leveling required and mounts in any position
- Quick response to temperature changes
- Nickel plated element

## Specifications

Dimensions ..... 5.38"H + 2.50"coil X 2.32"W X 2.57"D  
 Finish ..... Grey  
 UL/CUL file number ..... SA749

### 200 Series Refrigeration Temperature Controls

Range	Differential	Switch action	Motor rating (full load) 120 vac	Motor rating (full load) 240 vac	Resistive (non-inductive) 120 vac	Resistive (non-inductive) 240 vac	Model number	Item number
20 to 90°F (-6 to 32°C)	Adj. 3 to 20°F (1.5 to 11°C)	Close on Rise	16.0A	8.0A	25.0A	22.0A	201-8	02 01 008S1
-30 to 90°F (-34 to 32°C)	Adj. 3 to 20°F (1.5 to 11°C)	Close on Rise	16.0A	8.0A	25.0A	22.0A	201-20	02 01 020S1

See White-Rodgers General Information for full electrical ratings. 201-8 and 201-20 are rated FGH.



PS1-X5A

# PS1 Series Pressures Switch Single Control

PS1 Single Pressure Controls are designed for use on high and low pressure applications in refrigeration, air conditioning and heat pump systems, providing single-device control of the compressor or other electrical device.

### Features

- Adjustable pressures and differentials
- Narrow adjustable differential depending on model
- Range and differential pointer in units bar and psig
- Range and differential individually lockable by tab
- High rated SPDT contacts for all versions
- Captive terminal and cover screws
- Manual toggle for system checkout and override
- Automatic and manual reset versions available

### Specifications

Electrical ratings..... SPDT Switch Rated for 12 FLA and 72 LRA  
 ..... at 240 VAC and 16 FLA and 96 LRA at 120 VAC  
 UL/CUL file number..... E85974,  
 ..... CE per (LVD) Low Voltage Directive

### Model number nomenclature - Example: PS1-X3A

Series	Function		Pressure range	Connection type	Sequential identifier	Customer special	Pack type
PS1	-X		3	A			
Single Adjustable Pressure Switch	X = Auto Reset Y = Manual Reset - External	External Range and Differential Adjustments	3 = 9"Hg to 102 psig (0.3 to 7 bar) 4 = 29 to 290 psig (2 to 20 bar) 5 = 87 to 464 psig (6 to 32 bar)	A = 1/4" SAE Male Flare K = 1 m (3 ft.) Cap Tube, 1/4" Flare Nut	Blank Thru -99	G = Customer Special  (Omit for Standard)	B1 = Bulk Pack  (Omit for Individual Pack)

### PS1 Pressure Switch Series Single Control

Control type Low / high	Function	Pressure range (psig)	Differential (psig)	Factory setting (psig)	Connection type	Model number	Item number
Low	Auto Reset	9"Hg to 102 psig (0.3 to 7 bar)	15 to 73 psig (1.03 to 5.03 bar)	49/65 psig (3.4/4.5 bar)	1/4" SAE Male Flare	PS1-X3A	099022
Low	Auto Reset	9"Hg to 102 psig (0.3 to 7 bar)	15 to 73 psig (1.03 to 5.03 bar)	49/65 psig (3.4/4.5 bar)	1m (3 ft.) Cap Tube, 1/4" Flare Nut	PS1-X3K	099024
High	Auto Reset	87 to 464 psig, 6 to 32 bar	44 to 218 psig (3.03 to 15.03 bar)	141/280 psig (9.7/19.3 bar)	1/4" SAE Male Flare	PS1-X5A	099026
High	Auto Reset	87 to 464 psig, 6 to 32 bar	44 to 218 psig (3.03 to 15.03 bar)	230/290 psig (15.9/20 bar)	1m (3 ft.) Cap Tube, 1/4" Flare Nut	PS1-X5K	099027
High	Manual Reset	87 to 464 psig, 6 to 32 bar	Fixed	290 psig (20 bar)	1m (3 ft.) Cap Tube, 1/4" Flare Nut	PS1-Y5K	099030



PS2-Y7A

# PS2 Series Pressure Switch Dual Control

PS2 Dual Pressure Controls are designed for use on high and low pressure applications in refrigeration, air conditioning, and heat pump systems. This control reacts to changes in either low or high side pressures, providing single-device control of the compressor or other electrical device.

## Features

- Adjustable pressures and differentials
- Narrow adjustable differential depending on model
- Range and differential pointer in units bar and psig
- Range and differential individually lockable by tab
- High rated SPDT contacts for all versions
- Captive terminal and cover screws
- Manual toggle for system checkout and override
- Factory installed wire bridge for reduced installation effort
- High side convertible from manual to auto reset.
- Automatic and manual reset models available

## Specifications

Electrical ratings.....SPDT Switch Rated for 12 FLA and 72 LRA at 240 VAC  
 .....and 16 FLA and 96 LRA at 120 VAC  
 UL/CUL file number..... E85974  
 .....CE per (LVD) Low Voltage Directive

### Model number nomenclature - Example: PS2-Y7A

Series	Function		Pressure range	Connection type
PS2	-Y		7	A
Dual Adjustable Pressure Switch	X = Auto Reset	Internal range and differential adjustments	7 = Left Side: 9"Hg to 102 psig (-0.3 to 7 bar) Right Side: 87 to 464 psig (6 to 32 bar)	A = 1/4" SAE Male Flare K = 1 m (3 ft.) Cap Tube, 1/4" Flare Nut L = 1 m (3 ft.) Cap Tube, 1/4" ODM Solder Connection
	Y = Low Side: Auto Reset High Side: Convertible Reset	External range and differential adjustments		

### PS2 Pressure Switch Dual Control

Function	Low pressure side			High pressure side			Connection type	Model number	Item number
	Pressure range	Differential range	Factory setting	Pressure range	Differential	Factory setting			
Auto Reset	4.4 to 102 psig, 0.3 to 7 bar	15 to 73 psig	49/65 psig	87 to 464 psig	Fixed	290 psig	1/4" SAE Male Flare	PS2-Y7A	099008
Manual Reset	4.4 to 102 psig, 0.3 to 7 bar	15 to 73 psig	49/65 psig	87 to 464 psig	Fixed	290 psig	1 m (3 ft.) Cap Tube w/1/4" Flare Nut	PS2-Y7K	099009



PSC-W6S 0097793

# PSC Series Mini Pressure Control

The PSC Mini Pressure Control is a commercial grade control with a standard plug connectible design that simplifies installation and service. Typical applications include high pressure limit/alarm, condenser fan cycling, low pressure limit/alarm, low pressure cycling, defrost termination/fan delay, and rupture guard alarm.

## Features

- Mini-size 2"X 1-1/2" X 2-3/4"
- Standard SPDT switch action
- Automatic or manual reset
- Models available with high temperature bellows and built-in pressure pulsation snubber for direct head mount high pressure sensing/limit applications
- Plug connectible with hub for 1/2" flexible conduit
- Factory preset to customer desired pressure specifications
- Precise, repeatable settings
- Narrow differential "Micro" switch available on low pressure models

## Specifications

Electrical rating standard switch .....SPDT Standard switch - High/low pressure  
 .....Load contact: 6 FLA - 36 LRA - 120/240 VAC  
 ..... Pilot duty: 240 VAC @ 120, 480 Va @ 240 VAC  
 Electrical rating micro switch..... Micro switch - Low pressure  
 ..... 2.5 FLA - 15 LRA - 120/240 VAC  
 ..... Pilot duty: 120 Va @ 120, 240 Va @ 240 VAC  
 Ambient temperature .....Storage -30° to +160°F, Operating -20° to +140°F  
 Low pressure - Single diaphragm maximum media temperature..... 150°F  
 High pressure - Bellow design maximum media temperature.....300°F  
 ..... Internal pressure pulsation snubber available for direct head mount  
 Weight..... Approximately 0.25 lb. depending on configuration  
 Compatibility .....HFC, HCFC, CFC  
 Worldwide approvals.....UL/CUL/VDE/TUV  
 UL/CUL file number..... E85974

### Model number nomenclature - Example: PSC-W6S 0097793

Series	Function	Pressure range / contacts	Pressure connections	Unique identifier
PSC	-W	6	S	0097793
Mini Pressure Control	<p>A = Pressure Control, Automatic, high or low pressure applications (single diaphragm option, 158°F rating, range 1-5 only, without snubber) (bellows option, 300°F rating, with snubber, range 6 only)</p> <p>B = Pressure Cut-Out, External Manual Reset, din/tuv approved (double diaphragm option, 158°F, without snubber, range 1-5) (bellows option, 300°F rating, with snubber, range 6 only)</p> <p>R = Pressure Control, External Manual Reset, high or low pressure applications (single diaphragm option, 158°F rating, range 1-5 only, without snubber) (bellows option, 300°F rating, with snubber, range 6 only)</p> <p>W = Pressure Limiter, Automatic, din/tuv approved (double diaphragm option, 158°F, without snubber, range 1-5) (bellows option, 300° F rating, with snubber, range 6 only)</p>	<p>Standard Contacts</p> <p>1 = low pressure 15" hg to 90 psig</p> <p>5 = high pressure 100 to 465 psig</p> <p>6 = high pressure 145 to 623 psig</p> <p>Microswitch Contacts</p> <p>J = low pressure 15" hg to 90 psig</p>	<p>K = 1m (3 ft) cap tube with 1/4" flare nut (range 1-5)</p> <p>I = 1m (3 ft) cap tube with 1/4" odm solder connection (range 1-5)</p> <p>S = 1/4" female flare fitting, schrader depressor (range 1-6)</p>	

PSC Series Mini Pressure Control

High event range (psig)	Differential range (psid)	Pressure setting	Reset function	Pressure connection	Electrical connection	Electrical ratings	Maximum over pressure	Mounting options	Model number	Item number
<b>Low pressure controls</b>										
15 to 90	9 Low/15 High	5/15	Auto	1/4" Female Flare with Schrader Depressor Range 1-6	DIN Plug with 1/2" NPTF Hub for Flex Conduit Connection 36" Cable	6 FLA/36 LRA	360 psig	Free Standing Direct Mount	PSC-A1S 0097849	097849
15 to 90	4 Low/7 High	1.5/6	Auto	1/4" Female Flare with Schrader Depressor Range 1-6	DIN Plug with 1/2" NPTF Hub for Flex Conduit Connection 36" Cable	2.5 FLA/15 LRA	360 psig	Free Standing Direct Mount	PSC-AJS 0097815 <sup>1</sup>	097815
<b>High pressure controls</b>										
145 to 623	72 Low/87 High	395	Pressure Cut-Out, External Manual	1/4" Female Flare with Schrader Depressor Plus Stainless Steel Bellows with Snubber, Range 1-6	DIN Plug with 1/2" NPTF Hub for Flex Conduit Connection 36" Cable	6 FLA/36 LRA	695 psig	Free Standing Direct Mount	PSC-B6S 0097998	097998
145 to 623	72 Low/87 High	320/395	Pressure Limiter, Auto	1/4" Female Flare with Schrader Depressor Plus Stainless Steel Bellows with Snubber, Range 1-6	DIN Plug with 1/2" NPTF Hub for Flex Conduit Connection 36" Cable	6 FLA/36 LRA	695 psig	Free Standing Direct Mount	PSC-W6S 0097793	097793

<sup>1</sup> Micro-Switch Construction.



**FD113-ZUK**

# FD113-ZUK Oil Pressure Safety

The FD113 Oil Pressure Safety Control senses the effective oil pressure on pressure lubricated compressors. If inadequate oil pressure exists, a time delay is energized. If the oil pressure does not recover to safe levels within the time delay setting, the compressor is shut down.

## Features

- Pressure range adjustable from 4 to 65 psid; Timer start pressure - timer stop pressure is 3 psid above timer start pressure
- A SPDT switch is used in the pressure portion of the control which allows the addition of a safe-light when desired
- Electronic timer is time-adjustable from 20 to 150 seconds supply voltage - 24 to 240 Volt AC/DC; timing unaffected by voltage or ambient temperature variations
- A SPDT manual reset switch is used in the timer module; Upon time-out, the compressor is stopped and an alarm circuit is energized; To restart the compressor and de-energize the alarm circuit, the reset button is pushed
- A factory installed Jumper allows the FD113 to be powered from a single source power; should separate circuits be desired for the timer and lockout switch, the Jumper can be removed

## Specifications

Approvals..... UL/CUL File Number E85974, VDE 0631/0660  
 ..... TÜV, CE 73/23/EWG, CE 93/68/EWG

Adjustable pressure range (psid)	Adjustable time delay	Supply voltage	Pressure connectors	Model number	Item number
4-65	20 to 150 Seconds (Factory-Set at 120 Seconds)	24 to 240V AC/DC	(2) 36" Capillary with 1/4" Flare Nut	FD113-ZUK	097456



**FSY-43S 0097782**

# FSY Series Electric Fan Speed Control

The FSY Fan Speed Control controls the head pressure in air - cooled condensers and is designed for use with permanent split capacitor and shaded pole fan motors.

## Features

- Connector includes 2 m. cable installed (FSF and FSO)
- Connector turnable (in 90° steps)
- Compact design
- State-of-the-art electronics
- Direct mount - Easily retrofit to suitable motor
- Low pressure turn off operation
- Adjustable pressure setting
- Multiple FSX controls can be used in parallel on multi - circuit condensers
- 2 Cable types: FSF-N15 with internal circuit design to comply with EC-Directive 89/336/EC (Electromagnetic compatibility requirements for Europe FSO-N15, standard with internal voltage spike and over current protection

## Specifications

Nominal current.....0.1 to 4 A max up to 104°F (40°C) + 0.1 to 2.5 A max up to 140°F (60°C)  
 Starting current .....Max 8 Amp  
 Temperature range..... Storage and transportation 30°C to 70°C  
 ..... Ambient temperature -20°C to 55°C,  
 ..... Medium temperature -20°C to 70°C  
 Supply voltage .....230 VAC + 15-20%  
 Enclosure ..... Provide enclosure to protect from direct rain,  
 ..... sunlight and external damage  
 Weight..... 3.5 ounces  
 Approvals..... UL/CUL file number E183816 CE low voltage  
 ..... directive 72/23/EC connector per DIN 43650

### Model number nomenclature - Example: FSY-43S 0097782

Series	Cut off mode	Max current rating	Pressure range	Pressure connection	Unique identifier
FS	Y	-4	3	S	0097782
Fan Speed Control	Y = 0, 1A min	4 = 4 Amps maximum at 104°F ambient temp.	3 = 12.4 to 28.4 (179.8 to 411.9 psig), modulating band 66 psig, factory setting 16.1 bar (233.5 psig)	S = 1/4" SAE female (7/16" -20 UNF) with Schrader Depressor	

### FSY Series Electric Fan Speed Control

Current rating	Adjustable range (psig)	Modulating band (psig)	Factory setting (psig)	Pressure connection	Voltage	Model number	Item number
4 (4 Amps Maximum at 104°F Ambient Operating Temperature)	180 to 411	66	233	S = (1/4" SAE Female, 7/16" -20 UNF with Schrader Depressor)	230 VAC + 15-20%	FSY-43S 0097782	097782

### FSY series parts list

Description	Model number	Item number
FSY Temperature Pressure Control DIN Connector (EMC)	FSF-N15 804640	097995

# A guide to the White-Rodgers numbering system

Older models start with the dash in the basic Model Number, then working to the left, eliminate all letters. The number remaining will give you the Series and Control Category listed in the box below.

EXAMPLE: 1F95-1291 Leave out the letter F, the number remaining is 195 or a 100 series of room thermostats

EXAMPLE: 21D18-3 Leave out the letter D, the number remaining is 2118 or a 2100 series of pre-packaged kits

Series	Control category	Series	Control category	Series	Control category
100	Room Thermostats	900	Flame Detectors	2400	Sequencers and Time Delay Relays
200	Space Thermostats	1000	Temperature Controls	2500	Solenoid Gas Valves
300	Fan or Limits	1100	Hot Water Controls	3000	Mercury Flame Sensors
400	Limits, Fans and Temperature Controls	1300	Zone Valves and Hydronics	3400	Commercial Motor Actuators
500	Fan, Limit or Fan and Limits	1600	Refrigeration Temperature	3600	Combination Gas Manifold Valves
600	Oil Controls	1700	Refrigeration Temperature	3700	Gas Water Heater Controls
700	Miscellaneous Controls	2000	Motorized Zone Dampers	3900	Commercial Economizers
800	Relays	2100	Pre-Packaged Kits	5000	Ignition Components

## Model and type number examples

Series	100	800	3600	Allows for up to 100 basic models in each
Model	165	848	3603	Basic model number within a series
Model	1A65	8B48	36C03	Letter after first or second digit of model number identifies another control model after the basic model, which allows expansion of the numbering system
Model		8B48A	36C03U	Letter after Model number (or absence of letter) identifies operator coil voltage* (see table below)
Type	1A65-641	8B48A-217	36C03U-333	Dash number identifies a specific device within a control model. Model number plus dash number/type number

## Voltage designations (60 hz)

Code *	Voltage	Voltage designations on gas valves & switching relays		
No Letter	24 VAC	No Letter —	24 VAC	36C03-333
A	120 VAC	Letter A —	120 VAC	36C03A-310
E	208 VAC	Letter E —	208 VAC	24A06E-1
G	240 VAC	Letter G —	240 VAC	24A06G-1
U	750mv DC	Letter U —	750mv DC	36C03U-333
Z	SPECIAL	Letter Z —	SPECIAL	24A06Z-1

\* These designations only apply to power consuming devices that operate at a specific voltage (relays, solenoids, gas valves, motors, etc.) They are not used with thermostats or temperature controls.

## Pipe size designations (gas valves only)

Pipe size	Suffix no.
3/8 x 3/8	1 thru 49
1/2 x 1/2 INV. FL.	50 thru 74
3/4 x 1/2	75 thru 90
1/2 x 3/8	100 thru 199
1/2 x 1/2	200 thru 299
1/2 x 3/4	300 thru 399

## Single stage mechanical low voltage thermostat legend

	Vertical	Horizontal	Example
Snap Action Contacts	C	D	1C30, 1D35
*Mercury Bulb Switch	E	F	1E30, 1F56

\* Mercury bulb thermostats are no longer produced. See current models for specifications.

# Electric & gas conversion & capacity tables

## Electric

### Conversion table for watts - amperes - volts

Watts	Voltage (ac - single phase)			
	120	208	240	277
	Amperes			
500	4.2	2.4	2.1	1.8
1000	8.3	4.8	4.2	3.6
1500	12.5	7.2	6.3	5.4
2000	16.7	9.6	8.3	7.2
2500	20.9	12	10.4	9
3000	25	14.4	12.5	10.8
3500	29.2	16.8	14.6	12.6
4000	33.3	19.2	16.7	14.4
4500	37.5	21.6	18.8	16.3
5000	41.7	24	20.8	18

### Variations of ohms law

$$I \text{ (Amps)} = \frac{P \text{ (Watts)}}{E \text{ (Volts)}} = \frac{E \text{ (Volts)}}{R \text{ (Ohms)}}$$

$$R \text{ (Resistance)} = \frac{E \text{ (Volts)}}{I \text{ (Amps)}} = \frac{P \text{ (Watts)}}{I^2 \text{ (Amps)}}$$

$$E \text{ (Volts)} = I \text{ (Amps)} \times R \text{ (Ohms)} = \frac{P \text{ (Watts)}}{I \text{ (Amps)}}$$

$$P \text{ (Watts)} = I^2 \text{ (Amps)} \times R \text{ (Ohms)} = I \text{ (Amps)} \times E \text{ (Volts)}$$

## Gas

### Conversion factors for gas valve capacities

Total heating value (btu/cu.)	Specific gravity	Conversion factor multiply listed capacity by:
less than 800	0.6	0.516
800 to 950	0.7	0.765
2500 (LP Gas)	1.53	1.62

### Rate of flow of gases through orifices

Table for natural gas at 3.5"W.C. With 1000 btu/cu. Ft., .65 Specific gravity and .82 Orifice coefficient.

Drill size	Diameter in.	Natural gas (btu/hr)	Drill size	Diameter (inches)	Natural gas (btu/hr)
56	0.0465	5,359	26	0.147	53,500
54	0.055	7,510	22	0.157	61,100
52	0.0635	10,000	18	0.1695	71,200
46	0.081	16,250	12	0.189	88,600
42	0.0935	21,680	6	0.204	103,200
38	0.1015	25,530	2	0.221	121,100
34	0.111	30,550	A	0.234	135,700
31	0.12	35,690	E(1/4)	0.25	154,900
30	0.1285	40,900			

### Maximum wire lengths for self-generation systems

Wire sizes	Max. Length (2-Wire cable)	Maximum combined length (2 single wires)
No. 18	30 ft.	60 ft.
No. 16	50 ft.	100 ft.
No. 14	80 ft.	160 ft.

Because of the small amount of power available on self-generating systems, the gas valve may not operate if there is too much resistance in the circuit. Therefore, choose a location that does not require any more wire than the recommended lengths shown in the table above.

### Heat & power equivalents

1 Btu.....	252 calories
1 Btu/Hr.....	0.293 watts
1 Watt.....	3.413 Btu/Hr
1 KW (1000 Watts).....	3413 Btu/Hr
1 Hp.....	0.746 KW

### Pressure conversion table

1" Water.....	.0361 lbs/sq.in. or 0.0735 in. Mercury
1" Mercury.....	13.6 in. water or 0.491 lbs/sq. in.
1 PSI.....	2.77 in. water or 2.036 in. Mercury

### Btu content of fuels

natural Gas.....	950 to 1,150 Btu/Cu. Ft.
Butane Gas.....	3,200 Btu/Cu. Ft.
Propane (LP) Gas.....	2,500 Btu/Cu. Ft.
No. 2 Oil.....	140,000 Btu/Gallon

Table for propane (lp) gas at 11.0"W.C. With 2500 btu/cu. Ft. 1.53 Specific gravity and .80 Orifice coefficient.

Drill size	Diameter in.	Lp gas (btu/hr)	Drill size	Diameter in.	Lp gas (btu/hr)
70	0.028	5,490	46	0.081	45,800
67	0.032	7,150	44	0.086	51,600
64	0.036	9,050	42	0.0935	61,100
61	0.039	10,600	38	0.1015	72,000
58	0.042	12,300	34	0.111	86,200
56	0.0465	15,100	30	0.1285	115,300
54	0.055	21,200	26	0.147	151,000
52	0.0635	28,200	22	0.157	172,000
50	0.07	34,200	18	0.1695	200,500
48	0.076	40,400			

# Full electrical ratings of White-Rodgers controls

Any number of motors may be operated from one control provided that neither the sum of the full load currents nor the sum of the locked rotor currents are greater than the rating of the control. If the electric load consists of an oil burner motor and ignition transformer in parallel, the motor current plus the transformer current cannot exceed the values shown.

## Motor (amps)

Power supply and load	Simplified rating code of white-rodgers controls												
	FG	FGH	HT	HTV	HH	B	CF	CL	FB	SPDT	R	HH2C	
												White	Red
120 VAC Full Load	14	16	14	10	7.4	7.4	8	10	7.4	7.4	3.2	7.4	7.4
120 VAC Locked Rotor	84	84	84	60	44.5	44.5	48	60	44.5	44.5	19.2	44.5	44.5
240 VAC Full Load	7	8	7	6	3.7	3.7	6	6	3.7	3.7	1.5	3.7	3.7
240 VAC Locked Rotor	42	42	42	36	22.2	22.2	36	36	22.2	22.2	9.6	22.2	22.2

## Valves, relays, motor starters (amps)

Power supply	Simplified rating code of white-rodgers controls												
	FG	FGH	HT	HTV	HH	B	CF	CL	FB	SPDT	R	HH2C	
												White	Red
0.3 to 12v DC	①	①	①	1.0	①	①	①	1.0	①	①	①	①	①
25 VAC	5.6	5.6	5.6	6.0	2.9	2.9	3.2	4.0	2.9	2.9	1.2	2.9	2.9
120 VAC	5.6	5.6	5.6	6.0	2.9	2.9	3.2	4.0	2.9	2.9	1.2	2.9	2.9
240 VAC	2.8	2.8	2.8	2.4	1.4	1.4	2.4	2.4	1.4	1.4	0.6	1.4	1.4
600 VAC	125VA	125VA	①	①	①	125VA	①	①	125VA	125VA	①	①	①

## Electric heaters (amps)

Power supply	Simplified rating code of white-rodgers controls												
	FG	FGH	HT	HTV	HH	B	CF	CL	FB	SPDT	R	HH2C	
												White	Red
120 VAC	25.0	25.0	14.0	10.0	7.4	25.0	8.0	10.0	25.0	24.0	5.0	②	②
240 VAC	22.0	22.0	7.0	6.0	3.7	20.0	6.0	6.0	20.0	20.0	2.5	②	②
277 VAC	18	18	①	①	①	18	①	①	18	①	①	②	②

## Lamps (watts)

Power supply	Simplified rating code of white-rodgers controls												
	FG	FGH	HT	HTV	HH	B	CF	CL	FB	SPDT	R	HH2C	
												White	Red
120 VAC	1000	1000	1000	700	500	500	700	700	500	500	200	②	②
240 VAC	1000	1000	1000	800	500	500	800	800	500	500	200	②	②

① Indicates that control CANNOT be used on that power supply and load. ② Indicates that control is not likely to be used on that power supply and load. 125VA means 125 volt amperes; for example: 125VA at 440 volts would be 125 + 440 equals 0.28 amperes

## Horsepower ampere table

Electrical ratings of White-Rodgers controls are always given in amperes. In general, these ampere ratings correspond to the various horsepower ratings given in the table.

The ampere rating of all motors will not necessarily correspond to the horsepower rating shown in the table. Therefore, the control device selected must have a rating that is equal to (or greater than) the actual full load and locked rotor currents of the motor.

Approximate horsepower	Full load	Locked rotor	Full load	Locked rotor
1/10	3	18.0	1.5	9
1/8	3.8	22.8	1.9	11.4
1/8	4.4	26.4	2.2	13.2
1/4	5.8	34.8	2.9	17.4
1/3	7.2	43.2	3.6	21.6
1/2	9.8	58.8	4.9	29.4
3/4	13.8	82.8	6.9	41.4
1	16	96.0	8	48
1-1/2	20	120.0	10	60
2	24	144.0	12	72
3	34	204.0	17	102

To learn more, visit  
[copeland.com/white-rodgers](https://copeland.com/white-rodgers)

R-4899-7 (9/25) White-Rodgers Wholesale Catalog  
©2025 Copeland LP.

**WHITE ▾ RODGERS**  
by **COPELAND**