

50A55-843 UNIVERSAL SILICON CARBIDE IGNITION INTEGRATED HSI FURNACE CONTROL KIT

Controls Gas Valve, Ignitor, Blower, Inducer, Humidifier and Air Cleaner. Replaces Most Trane, York, ICP and Amana White-Rodgers Models

FEATURES

- Includes flash code diagnostics.
- Replaces 50A50 and 50A55 controls (consult Integrated Silicon Carbide Module Reference Chart below).
- Fused to protect low voltage system transformers.
- Includes mounting hole template.
- Adjustable blower relay.

SPECIFICATIONS

Input Voltage	25 VAC 50 / 60 Hz
Maximum Input Current @ 25 VAC . . .	0.45 amp
Valve Relay	1.5 amp @ 25 VAC 50 / 60 Hz 0.6 pf
Ignitor Relay	6.0 amp @ 120 VAC 50 / 60 Hz (resistive)
Inducer Relay	2.2 FLA – 3.5 LRA @ 120 VAC
Circulator Relay	14.5 FLA – 25.0 LRA @ 120 VAC
Operating Temperature Range	-40 to +175°F (-40 to +79°C)
Humidity Range	5% to 93% relative humidity (non-condensing)



TECHNICAL HELP

Wiring / configuration / troubleshooting see pages 183–184

Model Number	Pre-Purge	Delay Heat		Delay Cool		Auto Reset
		ON	OFF	ON	OFF	
50A55-843	30 sec.	30 / 45	60 / 90 / 120 / 180	5	45 / 90	60 minutes

CROSS REFERENCE

50A55-843 Replaces:

031-00662-000	117284	50A50-131	50A50-405	50A55-843	D340035P01
031-00662-700	12L4201	50A50-142	50A50-406	52537074000	D340774P01
03101250000	1380686	50A50-143	50A50-408	52537077000	D341122P01
031-01250-000	1380698	50A50-205	50A50-438	56L8501	D341235P01
031-01250-700	1380699	50A50-206	50A50-471	75671	D341235P02
031-01266-000	14028	50A50-207	50A50-472	75672	D341235P03
031-01266-700	14029	50A50-208	50A50-473	78712	L38-798
031-01284-000	14030	50A50-209	50A50-474	8068142	L38-799
084141	14031	50A50-210	50A50-475	8068561	L38-800
1010806	194300330001	50A50-215	50A50-571	8068563	L38-801
102077-02	30757	50A50-216	50A55-143	83388	PCBBF117
102077-03	350486	50A50-229	50A55-241	99958174	X13120666010
10207704	3XA75	50A50-230	50A55-245	99958175	X13130436-01
102077-04	4DG53	50A50-240	50A55-250	CNT02789	X13130436010
10207706	4DG54	50A50-241	50A55-285	CNT02891	X13130436-02
102077-06	4DG55	50A50-245	50A55-286	CNT03799	X13130436-04
102077-09	4DG56	50A50-285	50A55-288	CNT1684	X13130436040
10207710	50A50-110	50A50-286	50A55-3797	CNT1686	X13640678040
102077-10	50A50-111	50A50-288	50A55-438	CNT1687	X13650597010
10207714	50A50-112	50A50-295	50A55-474	D330927P01	X4459
102077-14	50A50-113	50A50-296	50A55-476	D330930P01	X445901
10207719	50A50-130	50A50-298	50A55-571	D330934P01	

NOTE: Can also be replaced by 50M56U-843

50A55-843 TYPICAL SYSTEM WIRING DIAGRAM

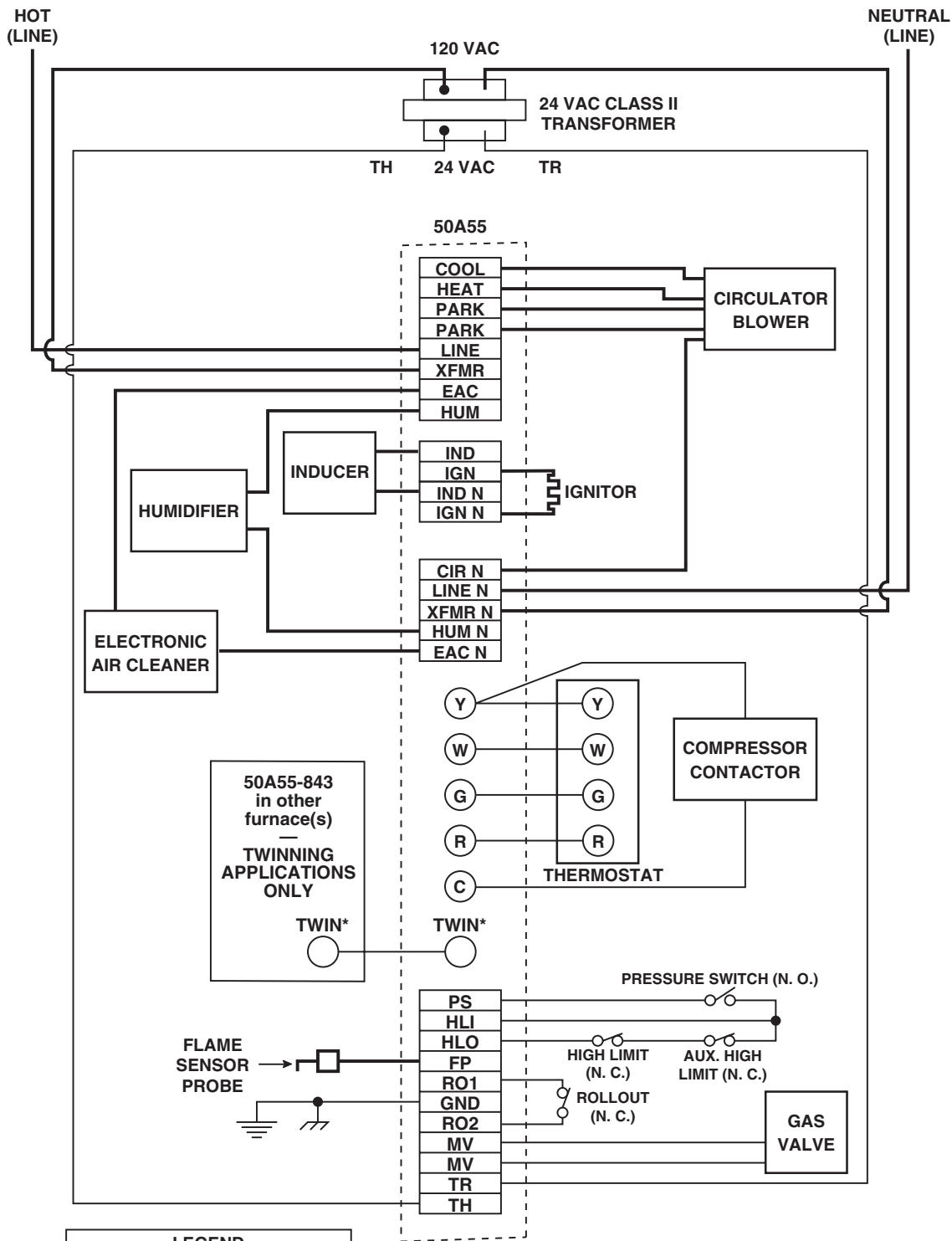

LEGEND	
—	Low Voltage (24 VAC)
—	Line Voltage (120 VAC)
○	N. C. = Normally closed switch
○	N. O. = Normally open switch

Flame Current Requirements:

- Minimum current to insure flame detection.....1 µA DC①
- Maximum current for non-detection.....0.1 µA DC①
- Maximum allowable leakage resistance..... 100 M ohms
- Flame establishing time.....0.8 seconds maximum
- Flame failure response time.....2.0 seconds maximum

① Measured with a DC microammeter in the flame probe lead

The 50A55-843 is an automatic gas interrupted ignition control that employs a microprocessor to continually monitor, analyze, and control the proper operation of the gas burner, inducer, and fan.

Signals interpreted during continual surveillance of the thermostat and flame sensing element initiate automatic ignition of the burner, sensing of the flame, and system shut-off during normal operation.

OPTION SWITCHES

The option switches on the 50A55-843 control are used to determine the length of the cool delay-to-fan-off, heat delay-to-fan-on and heat delay-to-fan-off periods. The following table shows the time periods that will result from the various switch positions.

OPTION SWITCH POSITIONS			
COOL delay-to-fan-off:	Set switch #1		
	45 sec.*	On	
	90 sec.	Off	
HEAT delay-to-fan-on:	Set switch #2		
	30 sec.*	On	
	45 sec.	Off	
HEAT delay-to-fan-off:	Set switch #3 #4		
	60 sec.	On	On
	90 sec.	Off	On
	120 sec.	On	Off
	180 sec.*	Off	Off

* Factory setting

HEAT MODE

In a typical system, a call for heat is initiated by closing the thermostat contacts. This starts the 50A55 control's heating sequence. The inducer blower and optional humidifier are energized and the ignitor is powered within one second.

This controller has an adaptive algorithm that adjusts the duration of the ignitor warm-up, to extend ignitor life. Upon initial application of power, the warm-up time is 17 seconds. The ignitor on-time will then be increased or decreased depending on whether or not flame is achieved. The warm-up time is limited to a maximum of 21 seconds. During the first 64 warm-up periods following power-up, the warm-up time may not be less than 17 seconds.

Upon a call for heat, if the warm-up time has not been locked, it will be decreased by one second. This reduction of the ignitor on-time will continue until flame fails to be achieved (resulting in a retry).

In the event of a retry, the warm-up time will be increased by two seconds and locked in at that duration. Once the warm-up time is locked, it remains fixed until another call for heat results in a retry, in which case the warm-up time is again increased by two seconds and remains locked.

In the event of two successive retry attempts, the warm-up time will be unlocked and set to 21 seconds. If flame is then achieved, the warm-up time will begin adapting again with the next call for heat. If, however, this third attempt fails to achieve flame, the control will go into system lockout.

At the end of the ignitor warm-up time, both valves in the 36E manifold gas valve are opened. Flame must be detected within 4 seconds.

See installation instructions for more system sequence detail.

COOL MODE

In a typical system, a call for cool is initiated by closing the thermostat contacts. This energizes the 50A55 control and

the compressor. The cool delay-to-fan-on period begins. After the delay period ends, the optional electronic air cleaner is energized, and the circulator fan is energized at cool speed. After the thermostat is satisfied, the compressor is de-energized and the cool mode delay-to-fan-off period begins. After the delay-to-fan-off period ends, the circulator fan and electronic air cleaner (optional) are de-energized.

MANUAL FAN ON MODE

If the thermostat fan switch is moved to the ON position, the circulator fan (cool speed) and optional electronic air cleaner are energized. When the fan switch is returned to the AUTO position, the circulator fan and electronic air cleaner (optional) are de-energized.

SYSTEM LOCKOUT FEATURES

When system lockout occurs, the gas valve is de-energized, the circulator blower is energized at heat speed, and, if flame is sensed, the inducer blower is energized. The diagnostic indicator light will flash or glow continuously to indicate system status. **(System lockout will never override the precautionary features.)**

To reset the control after system lockout, do one of the following:

1. Interrupt the call for heat or cool at the thermostat for at least one second but less than 20 seconds (if flame is sensed with the gas valve de-energized, interrupting the call for heat at the thermostat will **not** reset the control).
2. Interrupt the 24 VAC power at the control for at least one second. You may also need to reset the flame rollout sensor switch.
3. After one hour in lockout, the control will automatically reset itself.

DIAGNOSTIC FEATURES

The 50A55-843 control continuously monitors its own operation and the operation of the system. If a failure occurs, the LED will indicate a failure code as shown below. **If the failure is internal to the control, the light will stay on continuously. In this case, the entire control should be replaced, as the control is not field-repairable.**

If the sensed failure is in the system (external to the control), the LED will flash in the following flash-pause sequences to indicate failure status (each flash will last approximately 0.25 seconds, and each pause will last approximately 2 seconds).

1 flash, then pause	System lockout
2 flashes, then pause	Pressure switch stuck closed
3 flashes, then pause	Pressure switch stuck open
4 flashes, then pause	Open limit switch
5 flashes, then pause	Open rollout switch
6 flashes, then pause	115 Volt AC power reversed / Improper ground
7 flashes, then pause	Low flame sense signal
Continuous flashing (no pause)	Flame has been sensed when no flame should be present (no call for heat)

The LED will also flash once at power-up.

Trane application - Jumper wire 151-2906 (provided with control) must be installed on the furnace from R01 to R02 of the 12-pin connector.