

GAS BURNERS

HSG200 & HSG400



WAYNE
Combustion Systems™

a Scott Fetzer company

HSG FEATURES

The Wayne Model HSG power gas burners are designed for performance, reliability, and easy installation. The burner converts easily to fire Natural Gas or LP Gas and the higher static capabilities will overcome most adverse draft conditions encountered. The HSG400 remains one of the most widely used power burners around the world in its firing range.

The burner has the ability to fire between the entire range and is easy to set up. Simply identify and install the correct orifice, set the gas valve pressure and adjust the primary and off cycle dampers.

DESIGNED FOR EASY SERVICEABILITY:



No need to remove the burner for normal service. The Gas Manifold assembly is easily removed for complete service or replacement of components



Easy, convenient external orifice change



Automatic, perfect alignment of combustion components



Primary Air Damper with indicator



Exclusive Off-Cycle Damper reduces drafting back through the burner between burner firing cycles and also allows for fine-tuning of burner combustion.

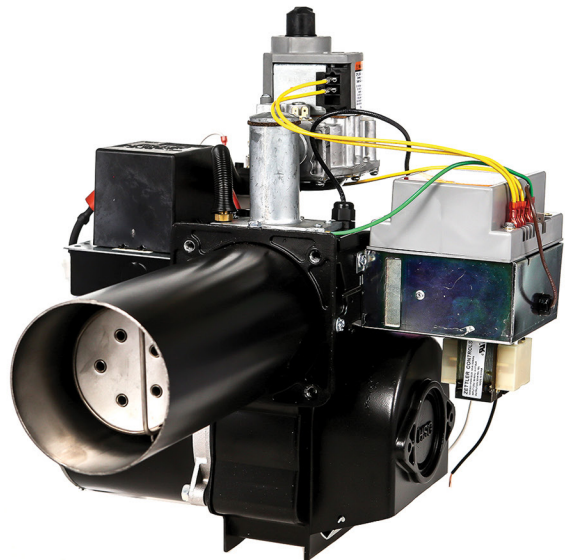

www.waynecombustion.com

Phone: 800.443.4625 | Email: sales@waynecombustion.com

SPECIFICATIONS

GAS BURNERS

HSG200 & HSG400

THE BLUE ANGEL™ POWER GAS BURNER - MODEL HSG

Minimum Firing Rate	<i>HSG200</i> : 60,000 Btu/hr <i>HSG400</i> : 200,000 Btu/hr
Maximum Firing Rate	<i>HSG200</i> : 200,000 Btu/hr <i>HSG400</i> : 400,000 Btu/hr
Voltage	120V, 60Hz (Can Run 50 Hz*)
Gas Pressure Required (Min-Max)	Natural Gas: 5.5" - 14" w.c. LP Gas: 5.5" - 14" w.c.
Ignition Source	Direct Spark Ignition
Gas Valve Operators	24 Vac
Gas Connection	3/4" NPT
Air Tube Diameter	4" OD Available in Lengths of 6", 9", 12"
Max. Air Tube Insertion Depth	Variable (See Chart Below)

SHIPPING INFORMATION

All **BLUE ANGEL Model HSG** flame retention Gas Burners are shipped completely assembled and test fired. Additional orifices supplied. Combination redundant gas valve and ignition control package installed.

Individually Cartoned | 18 Burners Per Pallet
Weight: 31-34 lbs ea.

Contact **Wayne Combustion Systems** for information regarding special HSG200 and HSG400 Gas Burners with modified timings that improve burner operation in applications such as bakery ovens and pressure washers.

*Reduces Maximum Output to 208,000 Btu/hr

Model	Part #	Airtube Length	Insertion Depth	Fuel	Ignition
HSG200	62376D	6"	5"	NAT or LP, 2" to 4" w.c. - adjustable	DI
HSG400	62377D	6"	5"	NAT or LP, 2" to 4" w.c. - adjustable	DI
HSG200	62378D	9"	8"	NAT or LP, 2" to 4" w.c. - adjustable	DI
HSG400	62379D	9"	8"	NAT or LP, 2" to 4" w.c. - adjustable	DI
HSG200	62380D	12"	11"	NAT or LP, 2" to 4" w.c. - adjustable	DI
HSG400	62381D	12"	11"	NAT or LP, 2" to 4" w.c. - adjustable	DI

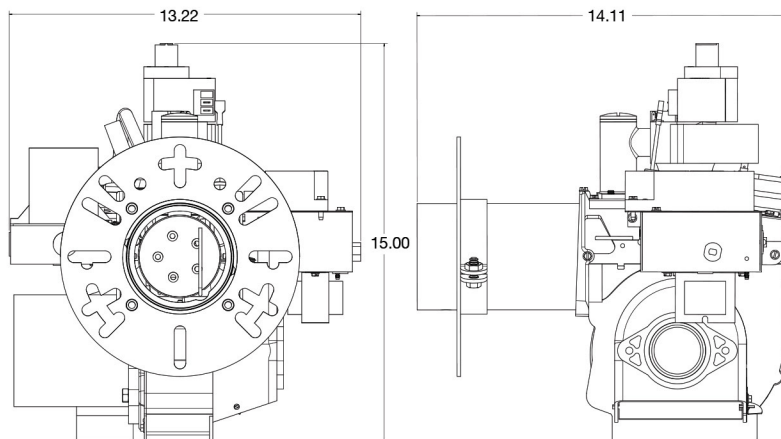

PLEASE CONTACT US FOR FURTHER INFORMATION :

Phone: 800.443.4625 | Email: sales@waynecombustion.com
www.waynecombustion.com