

DISCHARGE VIEW

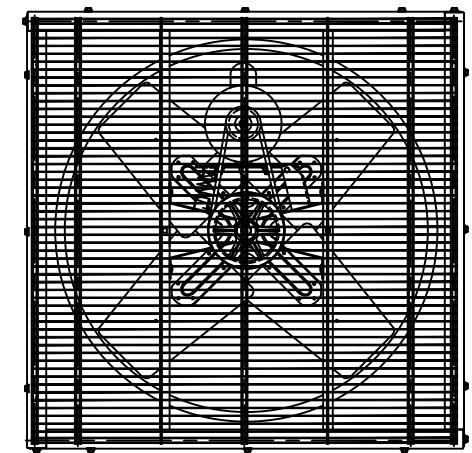
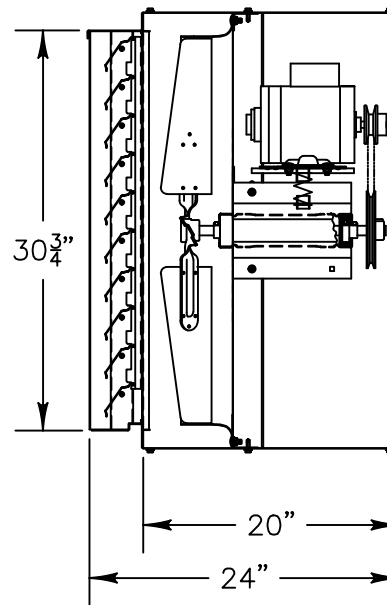

INTAKE VIEW

Exhaust Fan Specifications

Blade Diameter:	30"	Motor Enclosure:	TEFC
Drive:	Belt	Duty Cycle:	Continuous Duty
Horsepower:	1/2	Guard:	OSHA Compliant
Voltage:	115/230	Prewired:	115v
Phase:	1	Power Cord:	10' with molded plug
RPM:	740		

*See TriangleFans.com for performance specifications
 *Specifications are subject to change without notice



VIK3013T-U
 WALL FAN

NOT TO SCALE | 14 OCT 2015