



## SWING CHECK VALVE ♦ SINGLE DISC ♦ WOG 300

### DUCTILE IRON ♦ GROOVED ENDS

## MODEL: CV 31G-DI

Body: Ductile Iron  
Seat: EPDM  
Disc: Stainless Steel

**NSF**  
APPROVED  
COATING

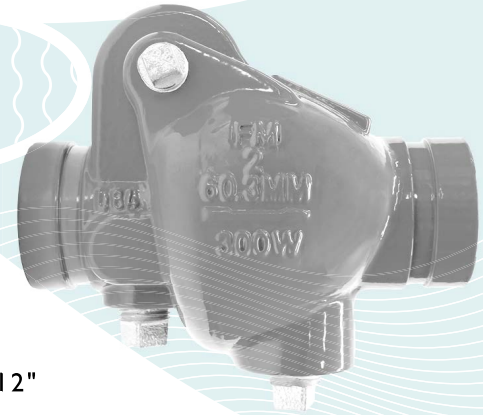

## FEATURES

SIZES: 2" ~ 12"

### ◆ GROOVED-END DESIGN

TITAN<sup>†</sup> UNIT CV31G GROOVED END DESIGN CAN BE QUICKLY AND EASILY INSTALLED WITH INDUSTRY STANDARD AWWA C606 COUPLINGS.

### ◆ MINIMAL HEAD LOSS

HEAD LOSS IS MINIMIZED BY PROVIDING A SHORT, STRAIGHT AND VIRTUALLY UNOBSTRUCTED FLOW PATH. ADDITIONALLY, THE SPRING-LOADED DISC IS DESIGNED WITH VERY LOW CRACKING PRESSURE WHICH REDUCES THE AMOUNT OF ENERGY REQUIRED TO OPEN THE VALVE.

### ◆ QUICK CLOSURE TO REDUCE WATER HAMMER

SHUT-OFF IS ACHIEVED VIA THE FULLY AUTOMATIC, SPRING-ASSISTED DISC THAT CLOSES NEAR ZERO FLOW VELOCITY. THE LIGHTWEIGHT, SINGLE DISC DESIGN CREATES A POSITIVE SHUTOFF PRIOR TO FLOW REVERSAL WHICH HELPS TO KEEP SURGES TO A MINIMUM.

### ◆ DURABLE, HIGH QUALITY DESIGN

THE CV31'S DUCTILE IRON BODY MAINTAINS THE ANTI-CORROSIVE PROPERTIES OF CAST IRON WHILE ACHIEVING A YIELD STRENGTH COMPARABLE TO CARBON STEEL. THE CV31G ALSO FEATURES ANTI-CORROSIVE, STAINLESS STEEL TRIM (DISC, SPRING, SHAFT) AS STANDARD.

### ◆ RESILIENT SOFT SEATS

RESILIENT SOFT SEATS (EPDM) COUPLED WITH PRECISION MACHINED SEALING SURFACES HELP TO ENSURE A BUBBLE TIGHT SEAL THAT MEETS OR EXCEEDS API 598 TEST REQUIREMENTS.

## TECHNICAL

PRESSURE/TEMPERATURE RATING  
SIZES: 2" ~ 12"

WOG (Non-shock): 300 PSI @ 100 °F

SEAT MATERIAL  
TEMPERATURE RANGE

EPDM: -20 ~ 250 °F

SPRING MATERIAL  
MAXIMUM TEMPERATURE

Series 304 Stainless Steel: 450 °F

1. The above listed temperatures are theoretical and may vary during actual operating conditions.
2. Max and min temperatures are for reference only. Prolonged use at these temperatures is not recommended for optimal service life.

## APPLICATIONS

**MARKETS:** GENERAL INDUSTRY, CHEMICAL, PETROCHEMICAL, POWER, AND FOOD & BEVERAGE

**SERVICE:** INTENDED FOR LIQUID SERVICE THAT IS STEADY, CLEAN (NO ABRASIVES OR SOLIDS) AND NON-PULSATING. FLOW RATE SHOULD NOT EXCEED 15 FT/SEC. NOT RECOMMENDED FOR STEAM OR RECIPROCATING COMPRESSOR SERVICE.

**EPDM PROPERTIES:** PROBABLY THE MOST WATER RESISTANT RUBBER AVAILABLE. IT HAS GOOD RESISTANCE TO MILD ACIDS, ALKALIS, SILICONE OILS/GREASES, KETONES, ALCOHOLS AND OTHER POLAR SOLVENTS. IT IS NOT RECOMMENDED FOR USE WITH PETROLEUM OILS, DI-ESTER LUBRICANTS, MINERAL OILS, NON-POLAR SOLVENTS OR AROMATIC FUELS.

*The above data represents common market and service applications. No representation or guarantee, expressed or implied, is given due to the numerous variations of concentrations, temperatures and flow conditions that may occur during actual service.*

**TITAN<sup>®</sup> FLOW CONTROL, INC.**  
**YOUR PIPELINE TO THE FUTURE!**

Tel: 910-735-0000 ♦ Fax: 910-738-3848 ♦ titan@titanfci.com ♦ www.titanfci.com  
290 Corporate Drive ♦ PO Box 7408 ♦ Lumberton, NC 28358



**TITAN® FLOW CONTROL, Inc.**

290 Corporate Drive  
Lumberton, NC 28358  
Tel: 910.735.0000

E-mail: titan@titanfci.com  
Web: www.titanfci.com  
Fax: 910.738.3848

• SWING CHECK VALVE • SINGLE DISC  
• GROOVED ENDS

**MODEL: CV 31G-DI (Ductile Iron Body)**

EPDM Seat • Stainless Steel Disc

WOG  
300

**BILL OF MATERIALS (1)**

No.	PART	CV 31G-DI
1	Body	Ductile Iron ASTM A536
2	Seat	EPDM
3	Disc (2)	Stainless Steel Type 304
4	Plug	Malleable Galvanized Iron
5	Spring (2)	Stainless Steel Type 304
6	Spacer	AISI 304
7	Shaft	AISI 304
8	Eye Bolt	Carbon Steel

1. Bill of Materials represents standard materials. Equivalent or better materials may be substituted at the manufacturer's discretion.
2. Denotes recommended spare parts.

**Section View**

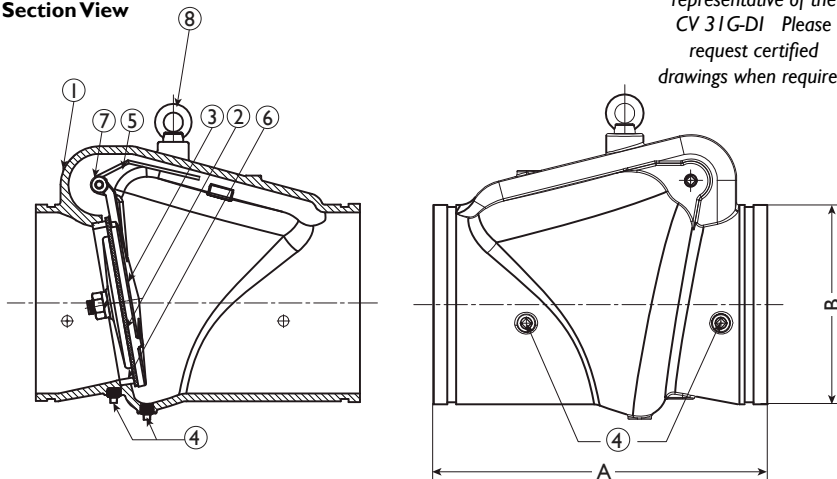

Illustrations are representative of the CV 31G-DI. Please request certified drawings when required.

**DIMENSIONS AND PERFORMANCE DATA (1)**

SIZE	in	2	2 1/2	3	4	5	6	8	10	12
	mm	50	65	80	100	125	150	200	250	300
<b>A</b> DIMENSION FACE TO FACE (2)	in	6.75	7.25	7.75	8.25	9.75	12.75	14.61	18.00	21.06
	mm	171	184	197	210	248	324	371	457	535
<b>ØB</b> DIMENSION OVERALL DIAMETER	in	2.37	2.87	3.50	4.50	5.56	6.63	8.63	10.75	12.75
	mm	60	73	89	114	141	168	219	273	324
ASSEMBLED WEIGHT	lb	7.25	8.00	10.3	16	21.75	35.6	60	115	167
	kg	3.3	3.6	4.7	7.3	9.9	16.2	27.2	52	75.7
Flow Coefficient	C <sub>v</sub>	112	140	250	390	700	1000	1800	3000	4200
Cracking Pressure (3)	psi	≤ .25	≤ .25	≤ .25	≤ .25	≤ .25	≤ .25	≤ .25	≤ .25	≤ .25

1. Dimensions, weights, and flow coefficients are for reference only. When required, request certified drawings.
2. Face to face values have a tolerance of ±0.06 in (±2.0 mm) for sizes 10" and lower and a tolerance of ±0.12 in (±3.0 mm) for 12" sizes.
3. Cracking pressure is for horizontal installations only. For vertical installations, please consult factory.

**Ductile Iron Application Notes:**

Ductile Iron maintains the anti-corrosive properties of Cast Iron while achieving a yield strength comparable to Carbon Steel.

**PRESSURE-TEMPERATURE RATINGS**

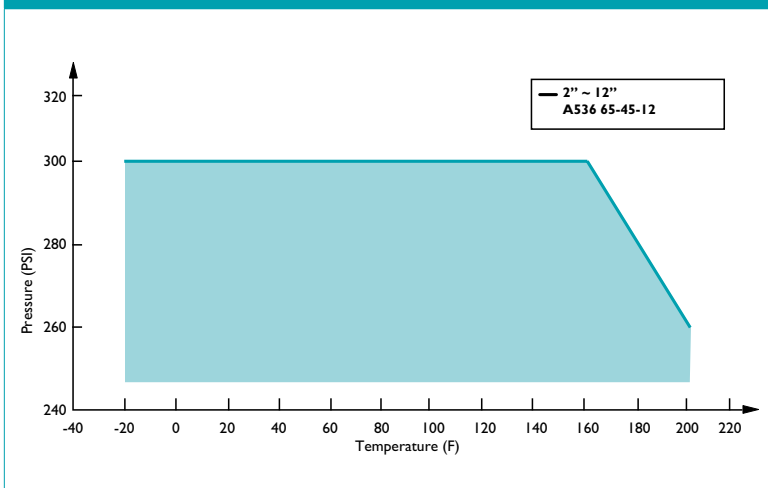

**REFERENCED STANDARDS & CODES**

CODE	DESCRIPTION
AWWA C606	Grooved and Shouldered Joints
API 598	Valve Inspection and Testing
MSS SP-25	Standard Marking System for Valves
MSS SP-55	Quality Standard for Valve Castings

**PRESSURE/TEMPERATURE RATING (1)**

Pressure Class	Ductile Iron A536
WOG (Non-shock)	300 PSI @ 100 °F

**SEAT AND SPRING TEMPERATURE RATINGS (2)**

SEAT	Temperature Range
EPDM	-20 °F ~ 250 °F
SPRING	Maximum Temperature
Series 300 Stainless Steel	450 °F

1. The listed pressure and temperature ratings for the valve's body, seat, and spring are theoretical and may vary during actual operating conditions.
2. Max and min temperatures are for reference only. Prolonged use at these temperatures is not recommended for optimal service life.