



Replacement Parts List

304-027

FM 1210, 1510 & 2010

Effective: March 10, 2014

Supersedes: February 15, 1992

WHEN SELECTING AND ORDERING PARTS, ALWAYS REFER TO SERIAL NUMBER ON NAME PLATE

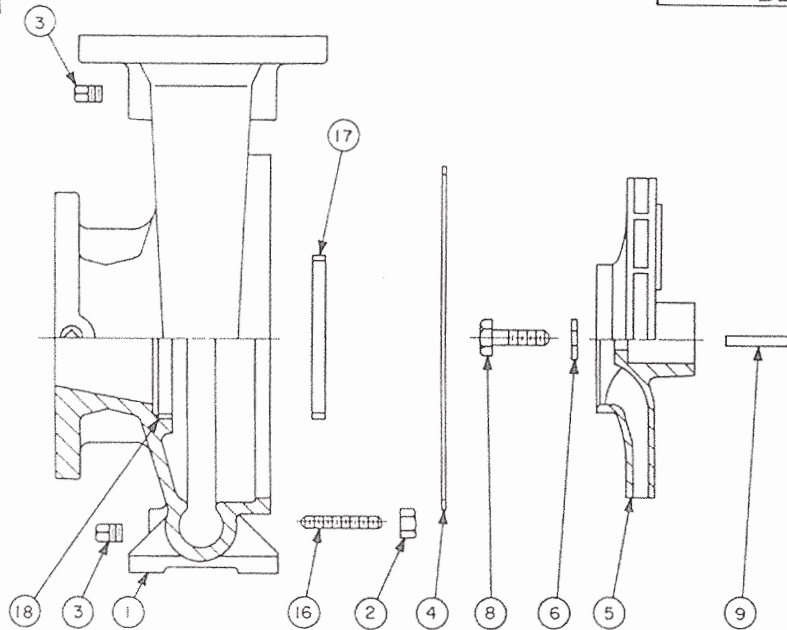
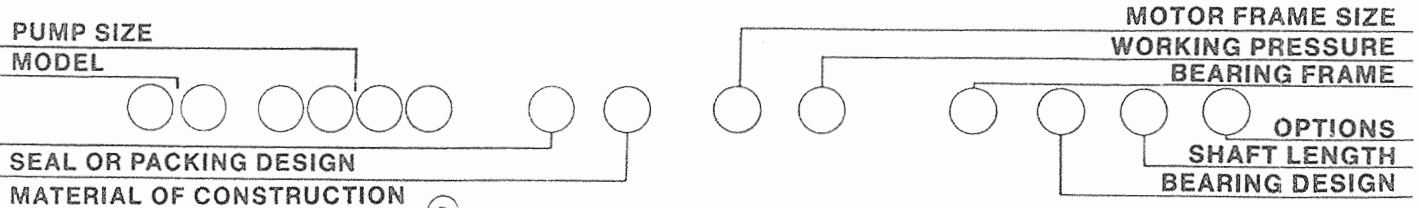

ITEM NO.	NO REQ.	DESCRIPTION	1210	1510	2010
1	1	CASING	950-1013RP	950-1014RP	950-1015RP
2	12	NUT	HARDWARE	HARDWARE	HARDWARE
3	2	SQ. HEAD PLUG	HARDWARE	HARDWARE	HARDWARE
4	1	GASKET	950-119RP	950-119RP	950-119RP
5	1	IMPELLER (CI)	950-1074RP	950-1075RP	950-1076RP
5	1	IMPELLER (BRZ.)	950-1074BRP	950-1075BRP	950-1076BRP
6	1	IMPELLER WASHER	950-047RP	950-047RP	950-046RP
8	1	IMPELLER BOLT	HARDWARE	HARDWARE	HARDWARE
9	1	IMPELLER KEY	HARDWARE	HARDWARE	HARDWARE
16	12	STUD	950-1159RP	950-1159RP	950-1159RP
17	1	WEAR RING (CI)	950-1164RP	950-1165RP	950-1166RP
17	1	WEAR RING (BRZ.)	950-1164BRP	950-1165BRP	950-1166BRP
18	1	DOWEL PIN	N/A	N/A	N/A
43	1	COVER WEAR RING (CI)	N/A	N/A	N/A
43	1	COVER WEAR RING (BRZ.)	N/A	N/A	N/A

FRAME SIZE & STYLE

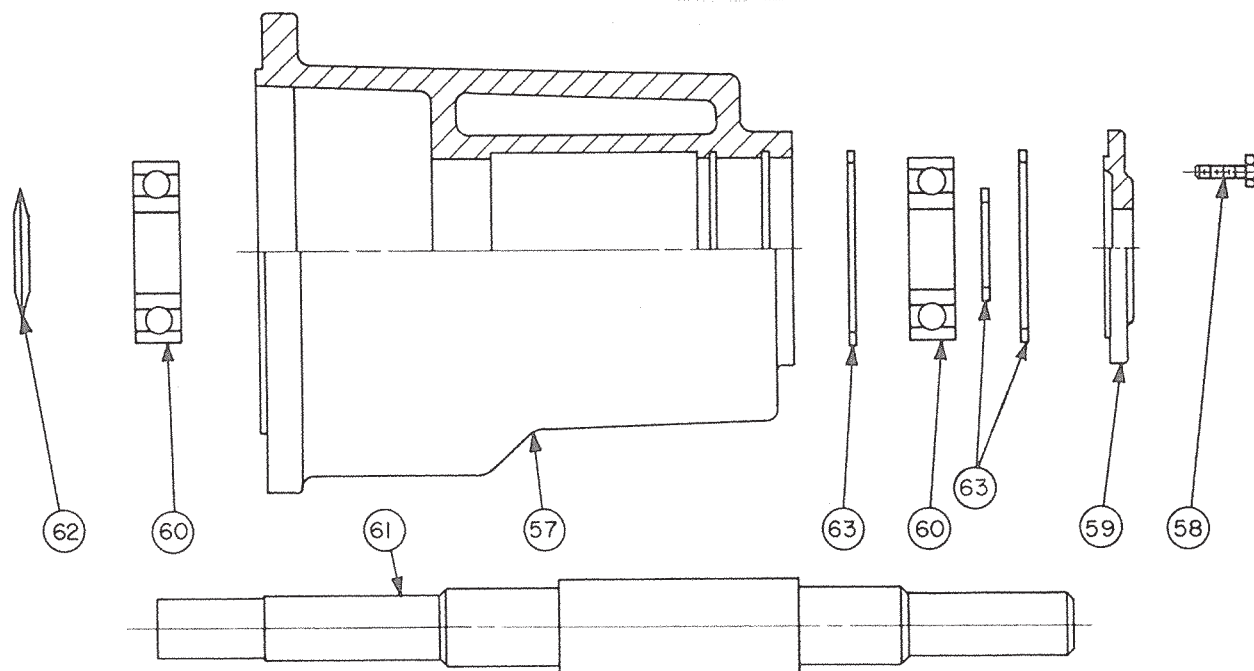

FRAME PARTS FOR "B" SIZE PUMP

ITEM NO.	NO. REQ.	DESCRIPTION	PART NO.	REMARKS
72	1	FRAME ASSEMBLY	950-1216RP	All Above Assembled As A Unit
57	1	FRAME	N/A	
58	8	HEX HD. SCREWS	HARDWARE	
59	2	BEARING COVER	950-1203RP	
60	2	BALL BEARING	862-101RP	
61	1	SHAFT	950-1206RP	
62	1	DEFLECTOR	N/A	
63	3	RETAINING RING	950-1209RP	
65	2	GREASE FITTING	950-1214RP	Not Shown
66	1	WASHER	HARDWARE	Not Included With Frame
67	1	BOLT	HARDWARE	Not Included With Frame

COVER MODULE FOR "B" SIZE PUMPS

ITEM NO.	NO. REQ.	SEAL OR PACKING TYPE	DESCRIPTION	1210	1510	2010
11	1	B-D-E	COVER	<-----950-1138RP----->		
11	1	P-Y	COVER	<-----950-1126RP----->		
24	8	NA	STUD	<-----950-1181RP----->		
25	8	NA	NUT	<-----HARDWARE----->		

SEAL OR PACKING DESIGN MECHANICAL SEAL

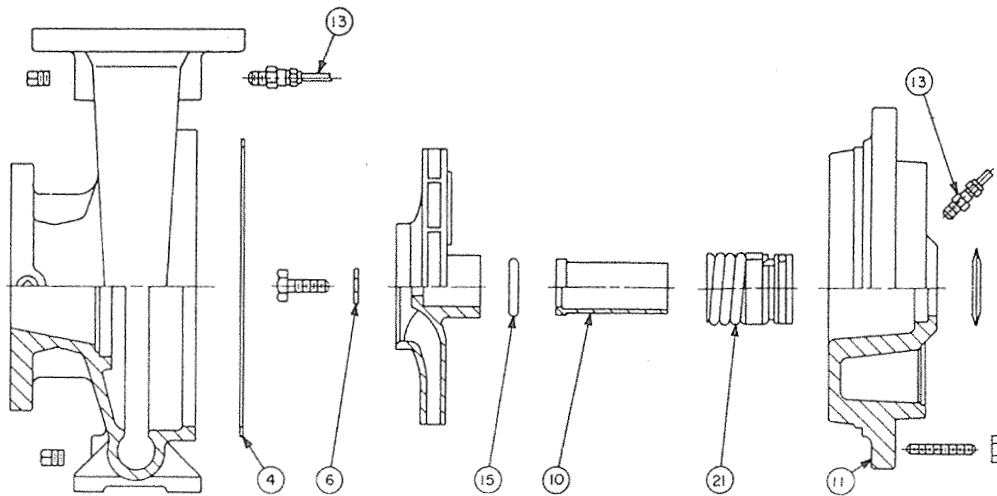

PACKING

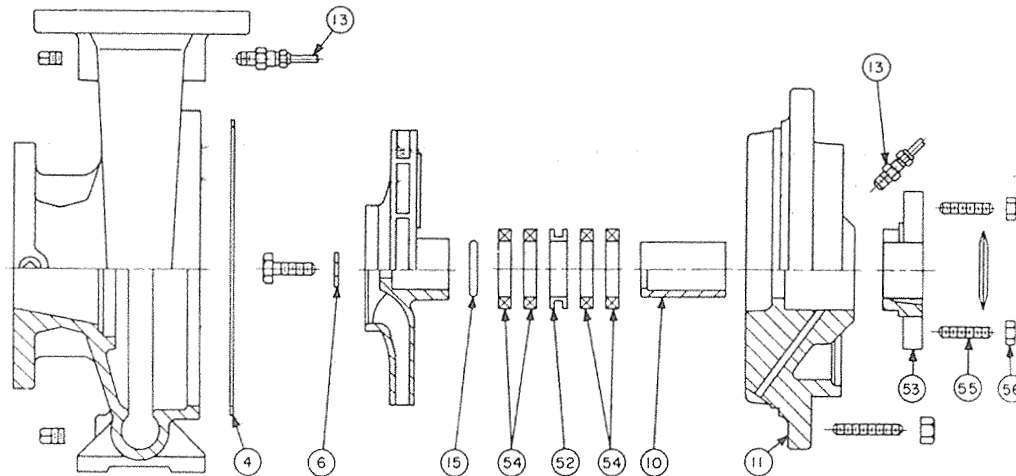

TYPE "B" STANDARD, TYPE "D" HI TEMP, TYPE "E" CERAMIC, TYPE "P" & "Y" PACKING

SEAL PARTS FOR "B" SIZE PUMPS

SEAL KIT INCLUDES ITEMS 4, 6, 10, 15 & 21

ITEM NO.	NO REQ.	DESCRIPTION	SEAL OR PACKING DESIGN				
			TYPE "B"	TYPE "D"	TYPE "E"	TYPE "P"	TYPE "Y"
4	1	GASKET	SEE PAGE 1				
6	1	IMP. WASHER	SEE PAGE 1				
10	1	SLEEVE (SS)	950-517RP	950-517RP	950-517RP		951-037RP
10	1	SLEEVE (BRZ.)	950-520RP	950-520RP	950-520RP		951-038RP
13	1	TUBE FITTING KIT	951-247RP	951-247RP	951-247RP		951-247RP
15	1	SLEEVE GASKET	950-111RP	950-111RP	950-111RP		950-111RP
30	1	SEAL KIT	950-665SRP	950-668SRP	950-671SRP		N/A
30	1	SEAL KIT	950-665BRP	950-668BRP	950-671BRP		N/A
52	1	LANTERN RING	N/A	N/A	N/A		950-1194RP
52	1	LANTERN RING (BRZ.)	N/A	N/A	N/A		950-1194BRP
53	1	GLAND	N/A	N/A	N/A		950-1197RP
53	1	GLAND (BRZ.)	N/A	N/A	N/A		950-1197BRP
54	4	PACKING RING	N/A	N/A	N/A		950-1200RP
55	2	STUD	N/A	N/A	N/A		950-1300RP
56	2	NUT	N/A	N/A	N/A		HARDWARE

MOTOR PARTS—NOT PART OF SERIAL NUMBER—

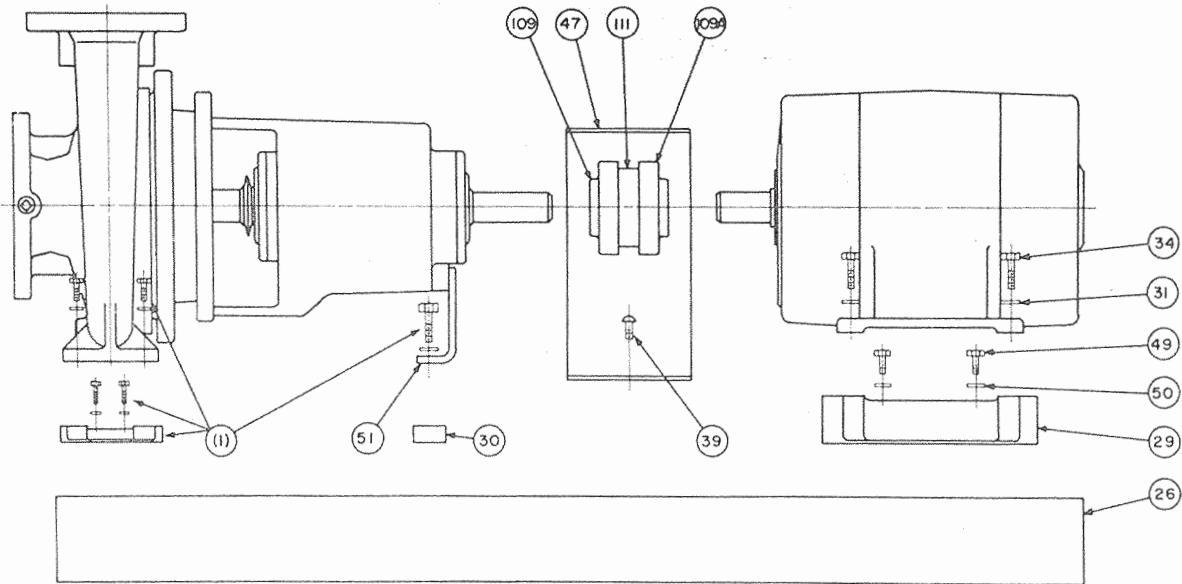

FOR FM PUMPS NO. 1210 & 1510 (1)

ITEM NO.	NO. REQ.	DESCRIPTION	MOTOR FRAME SIZE (NEMA STD.) 'T' (NOTE 2)						
			145T	182T	184T	213T	215T	254T	256T
26	1	BASE	CONSULT FACTORY						
29	2	MTR. SPACER	CONSULT FACTORY						
30	1	FOOT SPACER	N/A						
31	4	MTR. LOCKWASHER	HARDWARE						
34	4	MTR. BOLT	HARDWARE						
39	2	C. G. SCREW	HARDWARE						
47	1	COUPL. GUARD	840-125RP			862-164RP			
49	4	MTR. SPACER BOLT	HARDWARE						
50	4	MTR. SPACER L.W.	HARDWARE						
51	1	FRAME FOOT	950-1190RP						
109	1	PUMP COUPL. HALF	900-328RP			900-364RP			
109A	1	MTR. COUPL. HALF	900-325RP	900-327RP	900-328RP		900-365RP		
111	1	COUPL. INSERT	900-513RP			900-514RP			

NOTE (1): For Pump Spacers & Hardware, Consult Factory.

NOTE (2): For Motors Above 284TS, Consult Factory.

FOR FM PUMP NO. 2010 (1)

ITEM NO.	NO. REQ.	DESCRIPTION	MOTOR FRAME SIZE (NEMA STD.) 'T'						
			184T	213T	215T	284TS	286TS	324TS	326TS
26	1	BASE	CONSULT FACTORY						
29	2	MTR. SPACER	CONSULT FACTORY						
30	1	FOOT SPACER	N/A					950-188RP	
31	4	MTR. LOCKWASHER	HARDWARE						
34	4	MTR. BOLT	HARDWARE						
39	2	C. G. SCREW	HARDWARE						
47	1	COUPL. GUARD	840-125RP			862-164RP			
49	4	MTR. SPACER BOLT	HARDWARE						
50	4	MTR. SPACER L.W.	HARDWARE						
51	1	FRAME FOOT	950-1190RP						
109	1	PUMP COUPL. HALF	900-328RP		900-364RP	900-427RP			
109A	1	MTR. COUPL. HALF	900-327RP	900-328RP	900-365RP	900-428RP	900-437RP		
111	1	COUPL. INSERT	900-513RP		900-514RP	900-515RP			

NOTE (1): For Pump Spacers & Hardware, Consult Factory.

Do it Once. Do it Right.®

TACO INC., 1160 Cranston Street, Cranston, RI 02920 Telephone: (401) 942-8000 Fax: 942-2360
 TACO (Canada), Ltd., 6180 Ordan Drive, Mississauga, Ontario L5T 2B3 Telephone: (905) 564-9422
 Visit our website at: www.taco-hvac.com

Fax: (905) 564-9436

Printed in USA
 Copyright 2014
 TACO, Inc.