

Replacement Parts List

FI 5011 & FI 5011D

SUPERSEDES: NEW

EFFECTIVE: April 30, 2019

WHEN SELECTING AND ORDERING PARTS, ALWAYS REFER TO SERIAL NUMBER ON NAMEPLATE

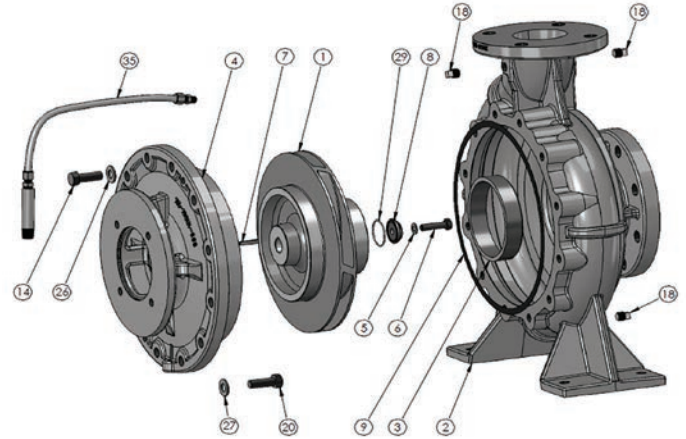
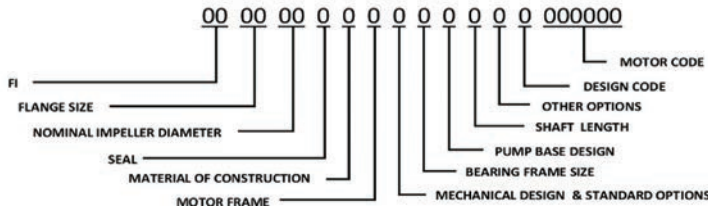

ITEM NUMBER	NUMBER REQUIRED	DESCRIPTION	FI 5011	FI 5011D
			BEARING FRAME J	BEARING FRAME J
1	1	Impeller (Bronze)	953-1103RP**	N/A
1	1	Impeller (BRZ) (With B/H, 1160, 1450 & 1760 RPM)	N/A	953-6345RP
1	1	Impeller (SS) (With B/H, 1160, 1450 & 1760 RPM)	N/A	953-6345SRP
2	1	Casing (125#) (No W/R)	953-1108RP	953-6339RP
2	1	Casing (250#) (No W/R)	953-1252RP	953-6340RP
2	1	Casing (125#) (Bronze W/R)	953-2322RP	953-6341RP
2	1	Casing (250#) (Bronze W/R)	953-2323RP	953-6342RP
3	1 (W/R)	Wear Ring (Bronze)	LE5263-12RP	953-6351LRP
4	1	Cover, 125#	953-908RP	953-6059-30RP
		Cover, 250#	953-908RP	953-6060-30RP
5	1	Dowdy Washer	951-2579RP	951-2579RP
6	1	Impeller Bolt (Stainless Steel)	1/2NCX1-1/2LG	1/2NCX1-1/2LG
7	1	Impeller Key (Stainless Steel)	1/4X1/4X2LG	1/4X1/4X2LG
8	1	Impeller Washer	953-829RP	953-829RP
9	1	Gasket (Casing)	953-1010RP	953-4221RP
14	12	Casing Bolt (Steel)	1/2NCX1LG	1/2 NC X 1 1/2 LG
18	4	Pipe Plug (Brass)	1/4NPT	1/4NPT
26	12	Casing Washer (Zinc)	1/2	1/2
29	1	Impeller Gasket	953-759RP	953-759RP
20	4	Motor Bolt	1/2NCX1-1/4LG	1/2NCX1-1/4LG
27	4	Motor Washer	1/2	1/2
35	1	Tube Kit	951-1547RP	951-1547RP

AW-695 Rev C

** 5011 IMPELLER IS AVAILABLE FOR ALL SPEEDS

FI Series 'J' Frame Replacement Parts

(for Bearing Frames manufactured after January 2003 - see note below)

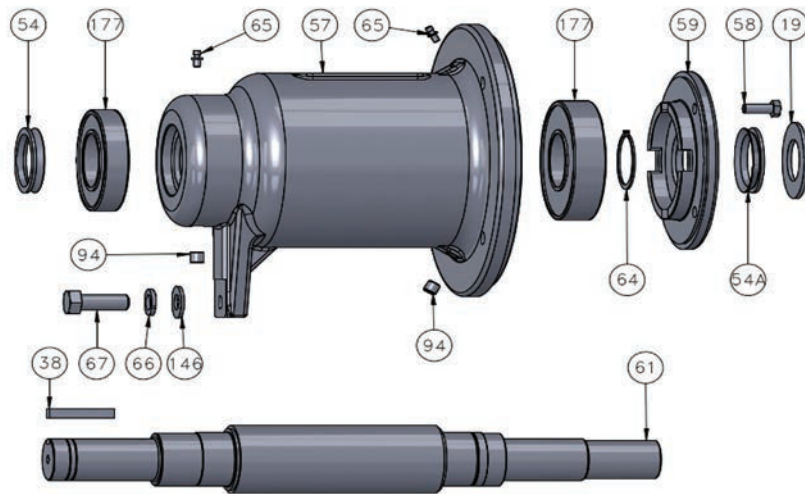

NOTE: Note difference in visual appearance of bearing frames on pages 2 and 3. New frames are a direct replacement for older ones. The part numbers for individual bearings are different from old frames to new frames. If you need help determining which frame you have, please contact tech services at Taco (401-942-8000).

ITEM NUMBER	NUMBER REQUIRED	DESCRIPTION	STANDARD SEALED BEARINGS	OPTIONAL GREASE-ABLE BEARINGS	REMARKS
			PART NO.	PART NO.	
-	1	FRAME ASSEMBLY (SS)	953-2222RP	953-2223RP	STAINLESS STEEL SHAFT
57	1	HOUSING	953-2203RP	953-2196RP	
61	1	SHAFT (SS)	953-2199RP	953-2199RP	STAINLESS STEEL
59	1	END CAP	953-2197RP	953-2197RP	
67	1	BOLT, FOOT SUPPORT	10-228RP	10-228RP	
66	1	LOCKWASHER, FOOT SUPPORT	14-102RP	14-102RP	
146	1	FLAT WASHER, FOOT SUPPORT	14-316RP	14-316RP	
38	1	KEY-SHAFT	13-110RP	13-110RP	
176	1	BALL BEARING, FRONT (THRUST)	953-2215RP	950-963RP	
177	1	BALL BEARING, REAR (RADIAL)	951-5599RP	951-2491RP	
19	1	DEFLECTOR	951-3040RP	951-3040RP	
64	1	RETAINING RING	15-140RP	15-140RP	
58	4	HEX HEAD BOLT, END CAP	10-207RP	10-207RP	
54	1	V RING SEAL, REAR	953-1575-3RP	953-1575-3RP	
54A	1	V RING SEAL, FRONT	953-1575-3RP	953-1575-3RP	
65	2	GREASE FITTING	N/A	15-203RP	
94	2	PIPE PLUG	N/A	16-140RP	

FI Series 'J' Frame Replacement Parts

(for Bearing Frames manufactured prior to January 2003 - see note below)

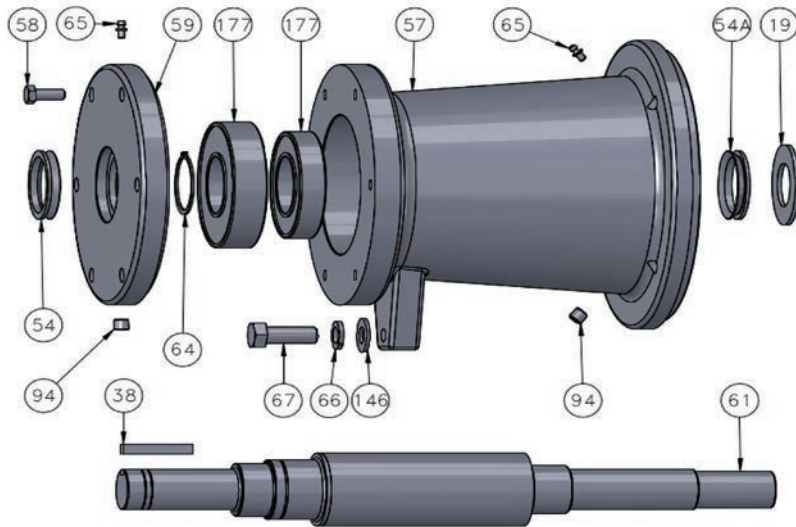

NOTE: Note difference in visual appearance of bearing frames on pages 2 and 3. New frames are a direct replacement for older ones. The part numbers for individual bearings are different from old frames to new frames. If you need help determining which frame you have, please contact tech services at Taco (401-942-8000).

ITEM NUMBER	NUMBER REQUIRED	DESCRIPTION	STANDARD SEALED BEARINGS	OPTIONAL GREASE-ABLE BEARINGS	REMARKS
			PART NO.	PART NO.	
-	1	FRAME ASSEMBLY (SS)	953-1572RP	953-1881RP	STAINLESS STEEL SHAFT
57	1	HOUSING	953-1565RP	953-1866RP	
61	1	SHAFT (SS)	953-1663RP	953-1663RP	STAINLESS STEEL
59	1	END CAP	953-1567RP	953-1869RP	
67	1	BOLT, FOOT SUPPORT	10-234RP	10-234RP	
66	1	LOCKWASHER, FOOT SUPPORT	14-102RP	14-102RP	
146	1	FLAT WASHER, FOOT SUPPORT	14-302RP	14-302RP	
38	1	KEY-SHAFT	13-110RP	13-110RP	
176	1	BALL BEARING, FRONT (THRUST)	953-1871RP	951-155RP	
177	1	BALL BEARING, REAR (RADIAL)	953-1876RP	862-101RP	
19	1	DEFLECTOR	951-3040RP	951-3040RP	
64	1	RETAINING RING	15-127RP	15-127RP	
58	4	HEX HEAD BOLT, END CAP	10-227RP	10-227RP	
54	1	V RING SEAL, REAR	953-1575-3RP	953-1575-3RP	
54A	1	V RING SEAL, FRONT	953-1575-4RP	953-1575-4RP	
65	2	GREASE FITTING	N/A	15-203RP	
94	2	PIPE PLUG	N/A	16-140RP	

AW-717 Rev H

FI Series Seal Replacement Parts (EPT)

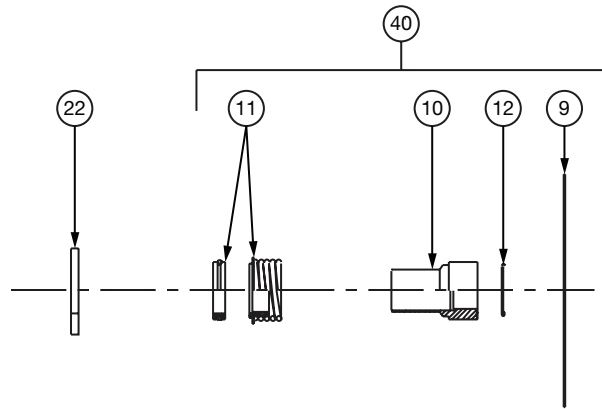

ITEM NO.	NO. REQ.	DESCRIPTION	5011, 5011D	5011, 5011D
			BEARING FRAME	
			J	J
			MECHANICAL DESIGN (125#)	MECHANICAL DESIGN (250#)
9	1	Gasket (Casing)	See Page 1	See Page 1
10	1	Sleeve (SS)	953-1170RP	953-1891RP
10	1	Sleeve (Brz)	953-1171RP	953-1887RP
11	1	Seal (Type B)	951-3158RP	951-5158RP
11	1	Seal (Type D)	951-3160RP	951-5159RP
11	1	Seal (Type E)	951-3162RP	951-5160RP
11	1	Seal (Type F)	951-6417RP	951-6456RP
12	1	Sleeve O-Ring	951-3042RP	951-3042RP
22	1	Deflector	951-3040RP	951-3040RP
40	1	Seal Kit (Type B) SS	953-1549-4RP	953-1549-10RP
40	1	Seal Kit (Type B) Brz	953-1549-4BRP	953-1549-10BRP
40	1	Seal Kit (Type D) SS	953-1549-5RP	953-1549-11RP
40	1	Seal Kit (Type D) Brz	953-1549-5BRP	953-1549-11BRP
40	1	Seal Kit (Type E) SS	953-1549-6RP	953-1549-12RP
40	1	Seal Kit (Type E) Brz	953-1549-6BRP	953-1549-12BRP
40	1	Seal Kit (Type F) SS	953-1549-42RP	953-1549-44RP
40	1	Seal Kit (Type F) Brz	953-1549-42BRP	953-1549-44BRP

From AW-698 Rev U

Motor Replacement Parts

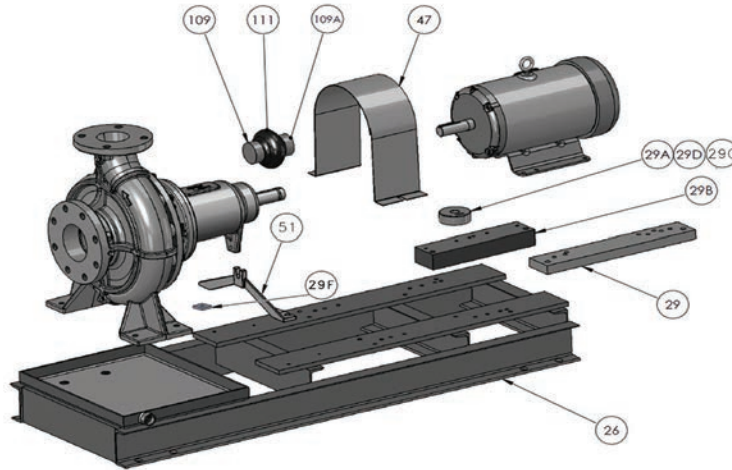

ITEM NUMBER	QUANTITY	DESCRIPTION	FI-5011 MOTOR FRAMES (NEMA STANDARD) "T"										
			143T	145T	182T	184T	213T	215T	254T	256T	284T	286T	324T
47	1	Coupler Guard	N/A	N/A	N/A	951-3574RP	951-3574RP	951-3574RP	951-3574RP	951-3574RP	951-3574RP	951-3574RP	951-3140RP
109	1	Coupler Hub, Pump	N/A	N/A	N/A	953-2437RP	953-2437RP	953-2437RP	953-2443RP	953-2450RP	953-2450RP	953-2458RP	953-2458RP
109A	1	Coupler Hub, Motor	N/A	N/A	N/A	953-2435RP	953-2437RP	953-2437RP	953-2445RP	953-2452RP	953-2454RP	953-2462RP	953-2463RP
111	1	Coupler Insert	N/A	N/A	N/A	953-2430RP	953-2430RP	953-2430RP	953-2438RP	953-2446RP	953-2446RP	953-2455RP	953-2455RP
*	1	OSHA Coupler Guard	N/A	N/A	N/A	953-1915RP	953-2755RP	953-2755RP	953-2755RP	953-2755RP	953-2755RP	953-2755RP	953-1916RP
26	1	Base	N/A	N/A	N/A	953-2267RP	953-2267RP	953-2267RP	953-4386RP	953-4386RP	953-4386RP	953-4386RP	953-2268RP
29	2	Spacer, Motor	N/A	N/A	N/A	951-5210RP	951-5204RP	951-5204RP	N/A	N/A	N/A	N/A	N/A
29A	4	Spacer, Motor	N/A	N/A	N/A	N/A	N/A	N/A	953-2228RP	953-2228RP	N/A	N/A	953-2229RP

ITEM NUMBER	QUANTITY	DESCRIPTION	FI-5011D MOTOR FRAMES (NEMA STANDARD) "T"										
			143T	145T	182T	184T	213T	215T	254T	256T	284T	286T	324T
47	1	Coupler Guard	N/A	N/A	N/A	951-3079RP	951-3079RP	951-3079RP	951-3079RP	951-3079RP	951-3079RP	951-3079RP	951-3079RP
109	1	Coupler Hub, Pump	N/A	N/A	N/A	953-2437RP	953-2437RP	953-2437RP	953-2443RP	953-2450RP	953-2450RP	953-2458RP	953-2458RP
109A	1	Coupler Hub, Motor	N/A	N/A	N/A	953-2435RP	953-2437RP	953-2437RP	953-2445RP	953-2452RP	953-2454RP	953-2462RP	953-2463RP
111	1	Coupler Insert	N/A	N/A	N/A	953-2430RP	953-2430RP	953-2430RP	953-2438RP	953-2446RP	953-2446RP	953-2455RP	953-2455RP
*	1	OSHA Coupler Guard	N/A	N/A	N/A	953-2755RP	953-2755RP	953-2755RP	953-2755RP	953-2755RP	953-2755RP	953-2755RP	953-1916RP
26	1	Base	N/A	N/A	N/A	953-6224RP	953-6224RP	953-6224RP	953-6225RP	953-6225RP	953-6225RP	953-6225RP	953-6435RP
29	2	Spacer, Motor	N/A	N/A	N/A	953-2635RP	951-5204RP	951-5204RP	N/A	N/A	N/A	N/A	N/A
29A	4	Spacer, Motor	N/A	N/A	N/A	N/A	N/A	N/A	953-2228RP	953-2228RP	953-2229RP	953-2229RP	N/A
29B	2	Spacer, Motor	N/A	N/A	N/A	N/A	951-5208RP	951-5208RP	951-6292RP	951-6292RP	N/A	N/A	N/A
51	1	Foot/Support	N/A	N/A	N/A	953-1642RP	953-1642RP	953-1642RP	953-1642RP	953-1642RP	953-1642RP	953-1642RP	953-1642RP

AW-728 Rev G



Taco, Inc., 1160 Cranston Street, Cranston, RI 02920 | Tel: (401) 942-8000 | FAX: (401) 942-2360

Taco (Canada), Ltd., 8450 Lawson Road, Suite #3, Milton, Ontario L9T 0J8 | Tel: (905) 564-9422 | FAX: (905) 564-9436

Visit our web site: www.TacoComfort.com | Printed in USA | ©2019 Taco, Inc.

