

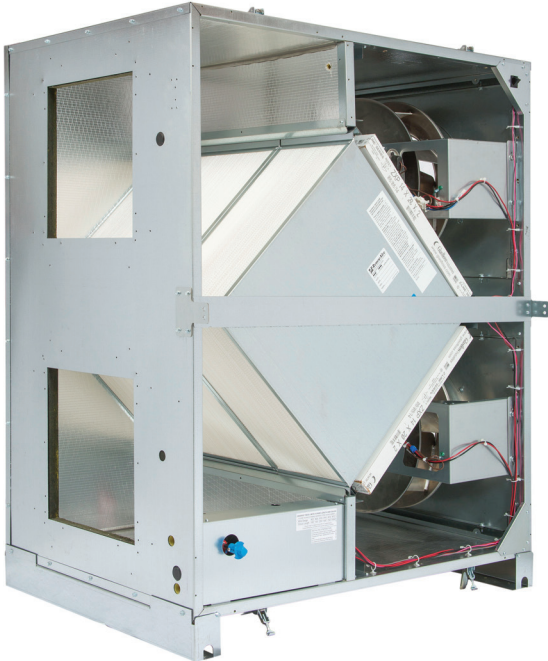

INSTALLATION, OPERATION & MAINTENANCE MANUAL
ENERGY RECOVERY VENTILATOR

TRC1200



TRC1200 INFO

ABOUT S&P

S&P USA operations are based in Jacksonville, Florida. This geographically strategic location allows the shipment of products throughout the US and Canada. The Jacksonville manufacturing facility has more than 150,000 square feet of warehouse space for the stocking of a comprehensive range of products. This permits the overnight delivery of many popular model sizes to anywhere in the US and Canada.

At S&P USA we take pride in the fact that our customers receive only the very highest levels of customer service and care. Our internal and external technical and customer service teams are on-hand to provide professional and experienced application advice to enable our customers to apply our products to their particular ventilation and air movement applications. As the USA sales, marketing and distribution division of the Soler & Palau Ventilation Group of companies we are committed to providing only the very highest levels of customer service. Our commitment in providing only the very highest standards of customer service is key to our company strategy.

Soler & Palau Ventilation Group is the world's leading fan manufacturer. It celebrated its 50th anniversary in 2001. Soler & Palau is able to offer a range of ventilation products benefiting from over 50 years of experience within the industry. The company's impressive, long-term growth is the result of one simple philosophy—develop an air-moving product that effectively and efficiently meets the needs of the customer, supported by unparalleled engineering, distribution and service.

In 1951 Eduard Soler and Josep Palau, both born in Ripoll, Spain, founded the company Soler & Palau (S&P). From the very start the business proved to be their vocation. Together they combined their extensive knowledge and flair to ensure the successful start of their business project. There is continual in-house product development with state-of-the-art technology, and a continued program of in-house laboratory certifications.

Currently S&P's R&D, manufacturing and distribution facilities occupy a total of 1.1 million square feet, with offices and locations around the globe. S&P products can be found in virtually any commercial or residential application, ranging from innovative, quiet and reliable room ventilators to large diameter, high capacity exhaust systems designed for critical applications in some of the world's toughest environments.

TABLE OF CONTENTS

TRC1200 info..... 3-4
Installation..... 5-14
Start-up..... 15-17
Maintenance..... 18-19

TRC1200 INFO

INDOOR UNIT

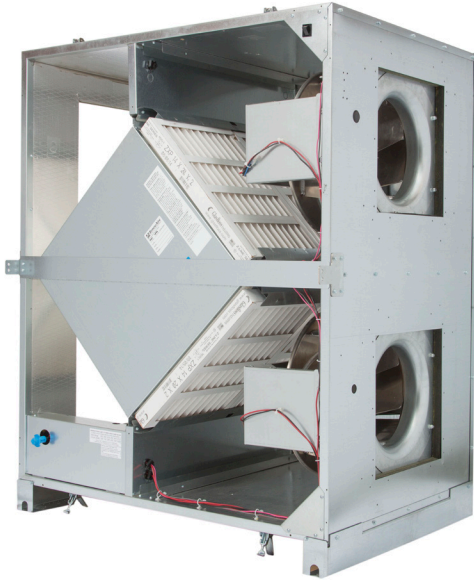

Ventilation Type:
Static plate, heat and humidity transfer

Typical Airflow Range:
375–1,575 CFM

AHRI 1060 Certified Core:
One L62-G5 and one L125-G5

Standard Features:
Non-fused disconnect
24 VAC transformer/relay package

Filters:
Total Qty. 4, MERV 8: (2) 14" x 20" x 2" and
(2) 16" x 20" x 2"

Unit Dimensions & Weight:
45 1/8" L x 33 1/2" W x 53 5/8" H
337 lbs.

Max. Shipping Dimensions & Weight (on pallet):
70" L x 47" W x 58 5/8" H
403 lbs.

Motor(s):
Qty. 2, 1.0 HP ea., Direct drive motorized
impeller packages

SPECIFICATIONS

NOTE: Specifications may be subject to change without notice.

Unless otherwise specified, dimensions are rounded to the nearest eighth of an inch.



AIRFLOW PERFORMANCE

Motor HP Phase	External Static Pressure (Inches Water Column)						
	0.0	0.25	0.50	0.75	1.00	1.25	1.50
1.0 Single Phase	1,575 CFM	1,470 CFM	1,350 CFM	1,225 CFM	1,090 CFM	950 CFM	795 CFM
	1,545 Watts	1,525 Watts	1,500 Watts	1,475 Watts	1,435 Watts	1,380 Watts	1,300 Watts
1.0 Three Phase	1,675 CFM	1,570 CFM	1,435 CFM	1,280 CFM	1,115 CFM	940 CFM	760 CFM
	1,410 Watts	1,400 Watts	1,380 Watts	1,340 Watts	1,280 Watts	1,210 Watts	1,135 Watts

NOTE: Watts is for the entire unit (2 motors).

NOTE: Airflow performance includes effect of clean, standard filter supplied with unit.

ELECTRICAL DATA

HP	V	HZ	Phase	FLA per motor	Min. Cir. Amps	Max. Overcurrent Protection Device
1.0	120	60	Single	6.5	14.6	20
1.0	208-230	60	Single	3.3-3.4	7.7	15
1.0	208-230	60	Three	2.2-2.2	5.0	15
1.0	460	60	Three	1.1	2.5	15

CORE PERFORMANCE

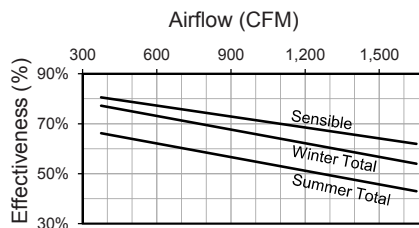

At AHRI 1060 standard conditions. See all AHRI certified ratings at www.ahrinet.org.

TRC1200 INFO

PRODUCT DIMENSIONS
TRC1200

ABBREVIATIONS
 EA: Exhaust Air to outside
 OA: Outside Air Intake
 RA: Room Air to be exhausted
 FA: Fresh Air to inside

INSTALLATION ORIENTATION
 Unit may be installed in any orientation.

NOTE
 1. UNLESS OTHERWISE SPECIFIED, DIMENSIONS ARE ROUNDED TO THE NEAREST EIGHTH OF AN INCH.
 2. SPECIFICATIONS MAY BE SUBJECT TO CHANGE WITHOUT NOTICE.
 3. MIN. DUCT CLEARANCE FROM DAMPER BLADE WHEN FULLY OPENED TO BE 2". SMACNA RULES APPLY.

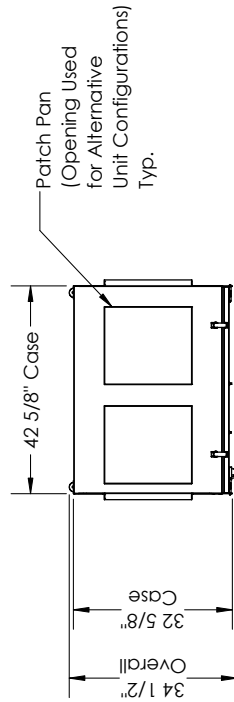

TOP VIEW

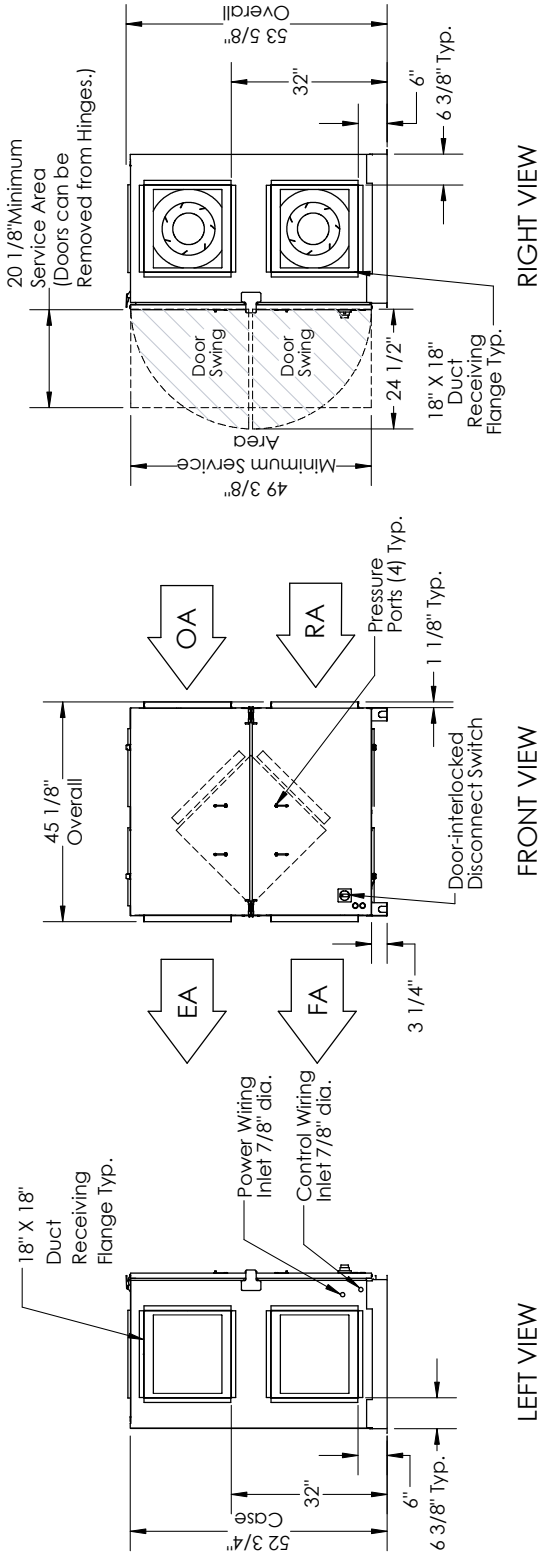

FRONT VIEW

LEFT VIEW

RIGHT VIEW

INSTALLATION

PLACEMENT OF THE TRC1200

The TRC1200 is designed for installation indoors. Select a location that is central to the inside duct runs, and close to both the exhaust duct (to the outside) and the fresh air duct (from the outside). The unit can be installed in any orientation but the contractor is responsible for safe installation of the unit.

**PLANNING
YOUR INSTALLATION**

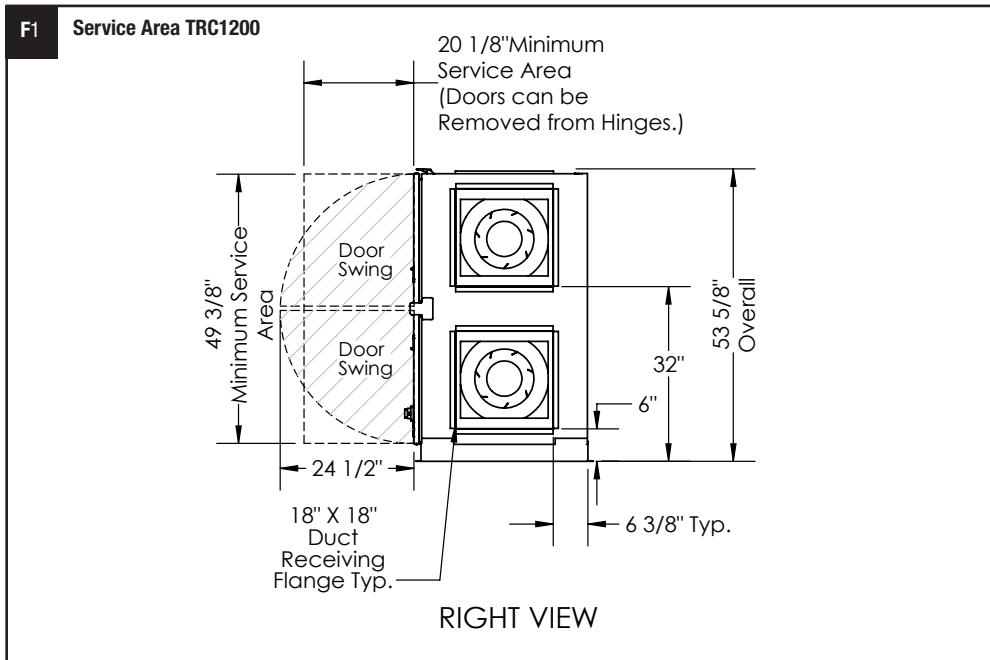

INSTALLATION

PLANNING
YOUR INSTALLATION

DUCTS TO THE OUTSIDE

The exhaust outlet and fresh air inlet on the outside of the building should be at least ten feet apart to avoid cross-contamination. The exhaust outlet should not dump air into an enclosed space or any other structure. The inlets and outlets should be screened against insects and vermin and shielded from the weather to prevent the entry of rain or snow.

NOTE: To prevent the entry of rain through the outside air inlet duct, observe the following:

1. Velocity at face of inlet hood should not exceed 500 feet per minute (fpm).
2. Inlet duct must be at least 18" x 18".
3. Centerline length along duct from weather hood to unit inlet must be at least 48".
4. Inlet duct must pitch downward to the outside; centerline of inlet hood must be at least 18" below the centerline of the unit inlet.
5. Outlet duct must pitch downward to the outside with a slope of at least ¼" to the foot.

Ducts connecting the TRC1200 to the outside must be insulated, with sealed vapor barrier on both inside and outside of the insulation. Insulate both the Outside Air (OA) and Exhaust Air (EA) ducts.

INSIDE DUCTWORK SYSTEM

Ensure Good Ductwork Design

Ductwork should be designed to allow the unit to provide the required airflow and reduce pressure drop for efficient, quiet operation. If the inside ducts run through unconditioned spaces they must be insulated with a sealed vapor barrier on both inside and outside of insulation.

 **WARNING**

The fresh air inlet should be at least 10' away from chimneys, furnace and water heater exhausts, and other sources of carbon monoxide, humidity or other contamination. Do not locate the fresh air inlet where vehicles may be serviced or left idling. Never locate the fresh air inlet inside a structure.

Use Non-motorized Dampers to Set and Balance Air

In most applications, the airflow rate for both the Fresh Air and the Exhaust Air should be roughly equal (or "balanced") for best performance of the TRC1200 Unit. See unit specification sheet for CFM/ESP curves.

APPLICATIONS

See figure F2 for examples of some common installation approaches.

PLANNING
YOUR INSTALLATION

F2 Common Installation Approaches

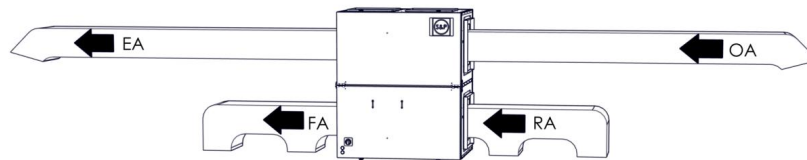

Conditioned Space

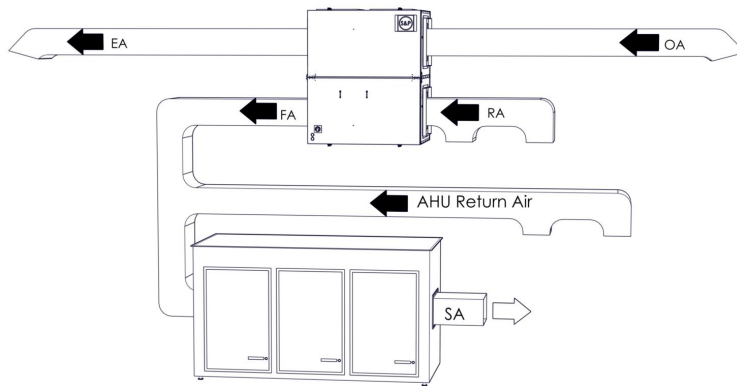

AHU

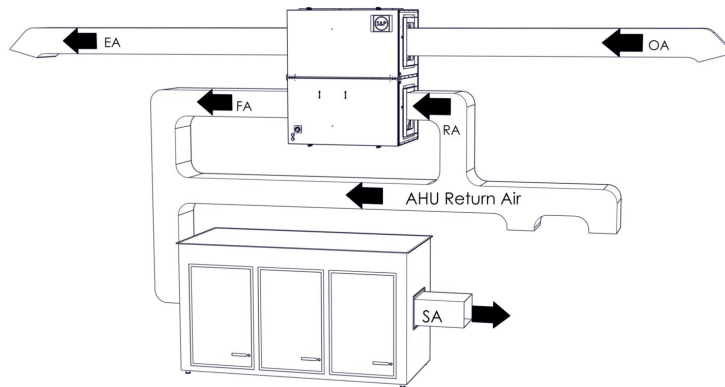

AHU

INSTALLATION

PLANNING
YOUR INSTALLATION **WARNING****RISK OF FIRE, ELECTRIC SHOCK, OR INJURY. OBSERVE ALL CODES AND THE FOLLOWING:**

1. Before servicing or cleaning the unit, switch power off at disconnect switch or service panel and lock-out/tag-out to prevent power from being switched on accidentally. More than one disconnect switch may be required to de-energize the equipment for servicing.
2. This installation manual shows the suggested installation method. Additional measures may be required by local codes and standards.
3. Installation work and electrical wiring must be done by qualified professional(s) in accordance with all applicable codes, standards and licensing requirements.
4. Any structural alterations necessary for installation must comply with all applicable building, health, and safety code requirements.
5. This unit must be grounded.
6. Sufficient air is needed for proper combustion and exhausting of gases through the flue (chimney) of fuel burning equipment that might be installed in the area affected by this equipment. If this unit is exhausting air from a space in which chimney-vented fuel burning equipment is located, take steps to assure that combustion air supply is not affected. Follow the heating equipment manufacturer's requirements and the combustion air supply requirements of applicable codes and standards.
7. Use the unit only in the manner intended by the manufacturer. If you have questions, contact the manufacturer.
8. This unit is intended for general ventilating only. Do not use to exhaust hazardous or explosive materials and vapors. Do not connect this unit to range hoods, fume hoods or collection systems for toxics.
9. When cutting or drilling into wall or ceiling, do not damage electrical wiring and other hidden utilities.
10. If installed indoors this unit must be properly ducted to the outdoors.

SOUND ATTENUATION

Take these simple steps to attenuate noise from the unit.

OUTSIDE THE BUILDING

Exhaust velocity noise is the primary cause of unit-related noise outside the building. Size the exhaust duct and grille for less than 1000 FPM air velocity. When practical, orient the exhaust air hood to point away from houses or public areas.

DUCTS

Make sure the ductwork at the unit outlets is stiff enough to resist the flexure and resulting booming associated with system start-up and shut-off.

In general, provide smooth transitions from the ERV's outlets to the duct. The ducts connecting to the outlets should be straight for a sufficient distance, with gradual transitions to the final duct size.

These guidelines are consistent with SMACNA recommended duct layout practices for efficient and quiet air movement. Follow SMACNA guidelines.

RADIATED NOISE

The TRC1200 is insulated with high-density fiberglass. This provides significant attenuation of radiated sound.

The inlet ducts can be significant sources of radiated sound as well. The OA and RA ducts (inlet ducts) should be insulated for sound control. This insulation should start at the unit. At a minimum the first ten feet of duct should be insulated. All parts of the OA and RA ducts located in the mechanical space should be insulated for sound control, both to minimize sound radiation out of these ducts and also to control sound radiation into the ducts.

CAUTION

To avoid motor bearing damage and noisy and/or unbalanced blowers, keep drywall spray, construction dust, etc., out of unit.

INSTALLATION

FIELD CONVERSION OF OPENINGS

The TRC1200 is designed to allow field conversion of the unit openings. This means the motorized impeller subassemblies can be moved to an adjacent wall of the unit if that opening is preferred. The outlet openings can also be moved to an adjacent wall. Before you start, plan the duct work layout. Determine which openings are to be converted.

TO FIELD CONVERT INLET OPENING

1. Disconnect motor harness connector (A) by the motor. Move the wire harness out of the way if necessary.
2. Support the impeller subassembly. Remove the eight ¼-20 bolts (B) retaining the impeller subassembly plate to the side rails and front and back tabs.
3. Lift the entire impeller subassembly (C) out of the unit and set aside. Leave the rails in the unit.
4. Remove the patch pan (D) from the desired opening.
5. Using the exposed sheet metal cutout, cut the insulation from the desired opening.
6. Seal the edges of the cut insulation to prevent erosion of the insulation edges and having debris in the air stream.
7. Install the patch pan over the undesired opening.
8. Install the insulation in the undesired opening. Seal the insulation.
9. Remove the duct flange from the undesired opening and install it at the desired opening.
10. If both inlet openings are to be converted, repeat Steps 2 – 9 for the second inlet opening.
11. At this point, if there are outlet openings for conversion, you will want to address them before proceeding with the inlet opening.
12. After converting the outlet openings move the unit floor brackets (E), if necessary, so when the unit is re-oriented the floor brackets support the unit on the floor.
13. Rotate the unit to the desired orientation, if necessary.
14. Install the impeller subassembly into the new inlet opening and fasten with eight ¼-20 bolts to retain to the side rails and front and back tabs. Make sure the motor harness connector is towards the front of the unit.
15. Connect the motor harness.
16. Repeat Steps 14 – 15 for other impeller subassembly if required.
17. Tidy up any wire harnesses that were moved making sure motor wires are taut and away from the impeller blades.

- Turn off the disconnect switch on the unit.
Make sure electrical power is shut off to the unit and disconnect switch.
- Remove the access doors from the unit.
- Remove the core strap, filters, and energy exchanger cores from the unit.

FIELD CONVERSION**TO FIELD CONVERT OUTLET OPENING**

1. Remove the patch pan (F) from the desired opening.
2. Using the exposed sheet metal cutout, cut the insulation from the desired opening.
3. Seal the edges of the cut insulation to prevent erosion of the insulation edges and having debris in the air stream.
4. Install the patch pan over the undesired opening.
5. Install the insulation in the undesired opening. Seal the insulation.
6. Remove the duct flange (G) from the undesired opening and install it at the desired opening.
7. If both outlet openings are to be converted, repeat Steps 1 – 6 for the second outlet opening.
8. If Inlet Openings are being converted return to Step 12 in the “To Field Convert Inlet Opening” instructions.

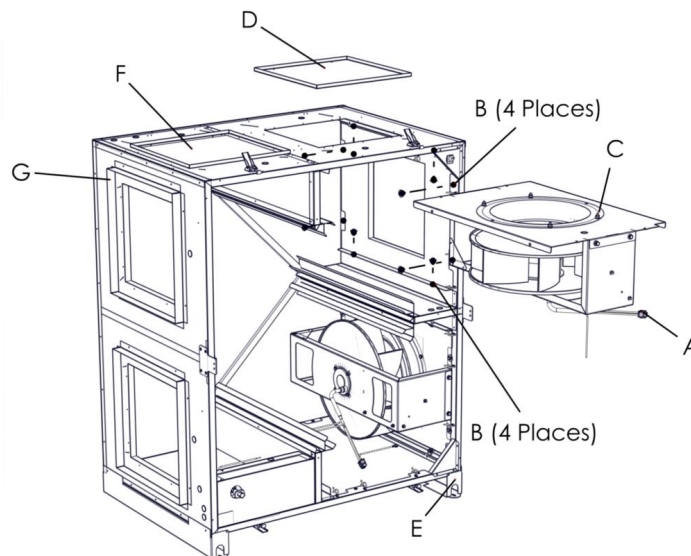

After completion of the field conversion,

- Clean out the interior of the unit to remove any debris.
- Install energy exchanger cores, filters, and core strap.
- Install access doors on the unit

INSTALLATION

INSTALLATION INSTRUCTIONS

ACCESSORIES

These ERVs may be ordered with factory-installed features including Isolation Dampers and Electronically Commutated Motors. Consult the supplemental Installation and Operation Manual(s) for these features if supplied.

WARNING

Standard TRC1200 with single phase original equipment motors are NOT suitable for use with solid state speed control.

Three phase motors are NOT suitable for use with solid state speed control.

Single phase ECM motors are NOT suitable for use with solid state speed control. They already have speed control built into the motor electronics.

Le TRC1200 avec moteurs d'équipement d'origine monophasés ne convient pas pour une utilisation avec regulateur de vitesse électronique.

Moteurs de trois phase ne convient pas pour utilisation avec regulateur de vitesse électronique.

Moteurs d'une phase de l'ECM ne conviennent pas pour une utilisation avec regulateur de vitesse électronique. Ils ont déjà le contrôle de vitesse intégré dans le moteur électronique.

CAUTION

The TRC1200 weighs 340 lbs. It is the installer's responsibility to make sure that the screws or bolts used for securing the units are properly selected for the loads and substrates involved.

WARNING

Secure the TRC1200 with straps or clamps so that it cannot fall or tip in the event of accident, structural failure or earthquake.

MOUNTING THE UNIT

The TRC1200 is manufactured with two floor stands for installation at floor level in an upright position. Adequate clearance for the access door latches must be provided.

The TRC1200 may also be hung on the wall or suspended from a ceiling. Screw or bolt mounting straps or brackets directly to the sheet metal case as necessary. Remove the access doors before installing screws — make sure your fasteners don't damage internal parts. Do not screw into the access doors.

ELECTRICAL SPECIFICATIONS

Use conduit, strain reliefs, etc. as required by code to secure the field wiring. Electrical knockouts are provided for alternate line voltage and voltage control locations for field wiring to the internal electrical box. If the alternate sites are desired for field wiring then carefully remove the knockout plugs from the alternate sites. Insulate and plug the open knockout locations.

NOTE: If your unit is equipped with EC Motors, please refer to "EC Motor Manual Supplement" for more detail.

INSTALLATION

TRC1200 P1 SINGLE PHASE UNIT WIRING SCHEMATICS

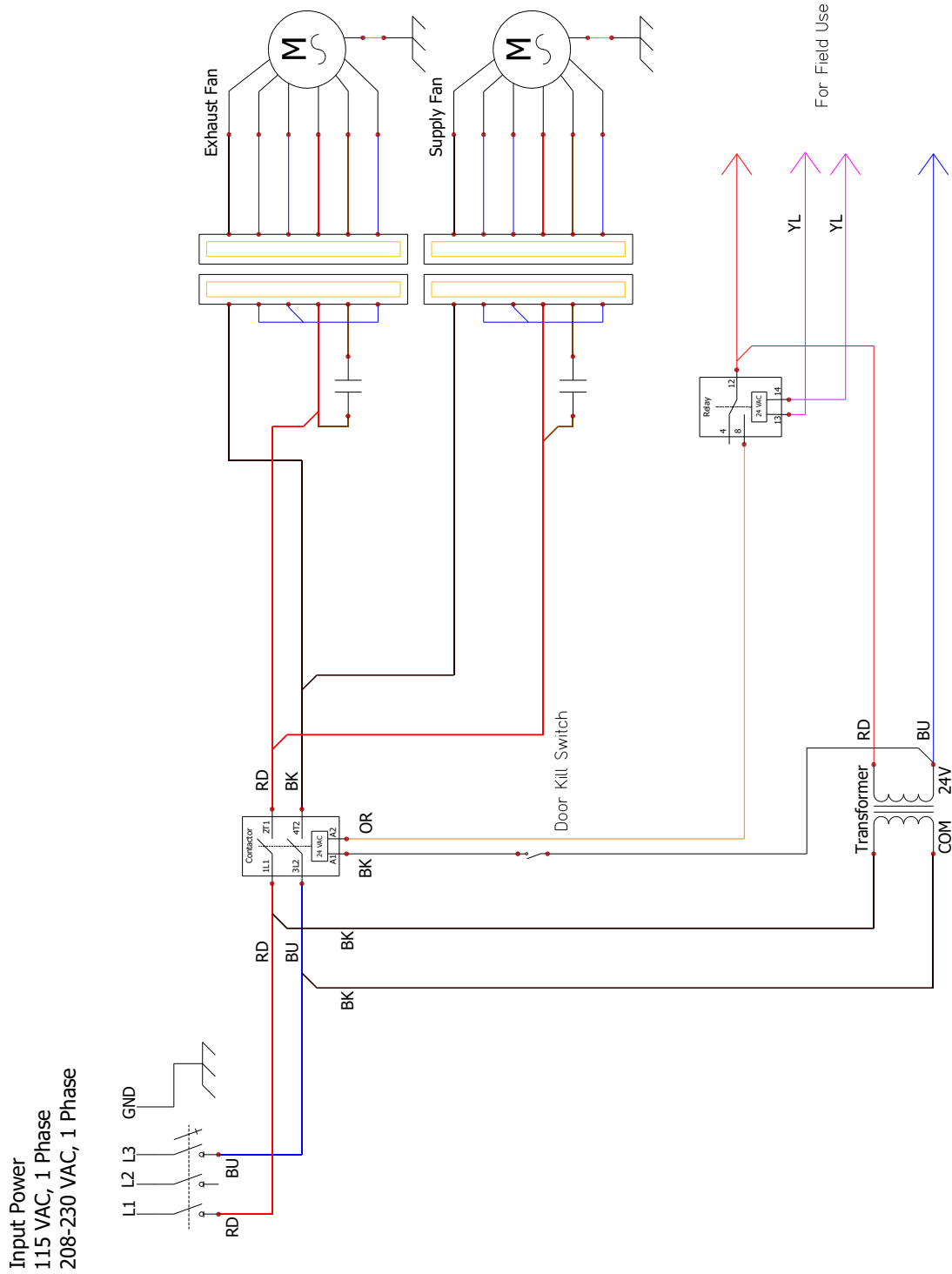

INSTALLATION

WIRING SCHEMATICS TRC1200 P3 THREE PHASE UNIT

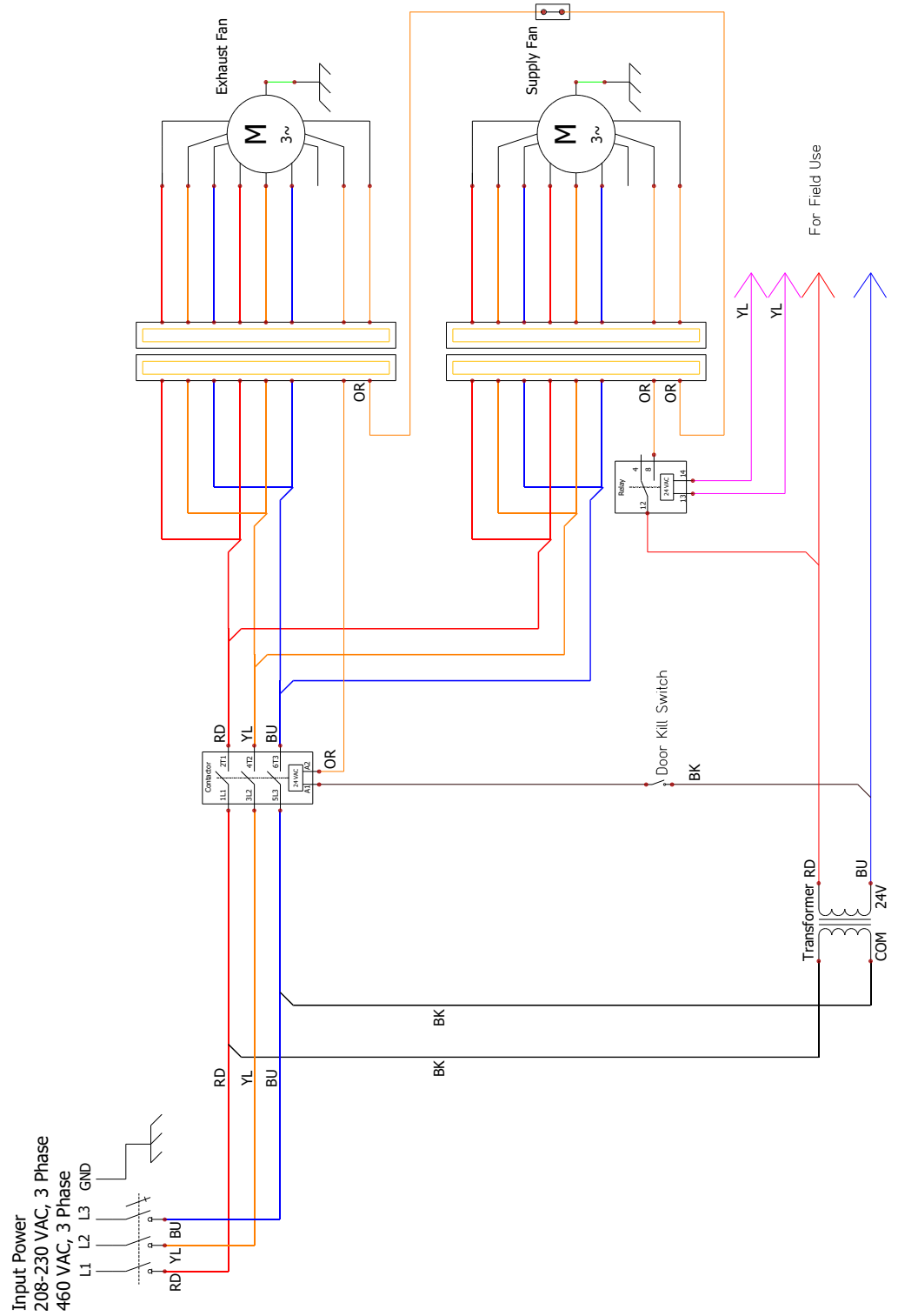

INSTALLATION

LOW VOLTAGE CONTROL SYSTEM

This ERV is provided with a Class II 24VAC power supply system that operates the unit’s contactor(s) for TRC1200. The ERV’s 24VAC Power Supply can also be used to power the externally-installed controls system: up to 8VA of power is available.

The unit’s power supply system includes isolation relay(s) so you can use external controls whose contact ratings are as low as 50mA (1.2VA). Also, it is possible to operate the isolation relays with 24VAC power from an external source (with proper wiring connections).

A built-in circuit-breaker prevents damage to the transformer and other low-voltage components in the event of a short-circuit or overload. In extreme cases, the transformer itself is designed to fail safely.

SPECIFICATIONS

- Nominal Output Voltage under load: 24VAC
- Typical Output Voltage at no load: 29-31V
- Minimum contact rating for connected control device: (50mA (1.2VA)
- Circuit Breaker Trip Point: 3A

INSTALLATION INSTRUCTION

CAUTION

1. Connect only to components intended for use with 24VAC power.
2. Do not undersize the low-voltage wires connected to this device. Observe the wire length and gauge limits indicated in this manual.
3. Do not overload this unit’s 24VAC power supply system. Confirm that the power requirements of devices you connect to this power supply system do not exceed 8VA in total.
4. If an external source of 24VAC power is used to control the unit, consult the wiring schematics and connect the external power only to the specified terminals in order to avoid damaging the unit or external controls. Connect only CLASS II power to the control terminals of this unit.
5. Unit is not equipped to receive analog signals (such as 1-10vdc or 4-20mA).
6. Unit is not equipped to communicate directly with Building Management Systems (such as BACNET, LONWORKS, etc.). However, the unit can be controlled by powered or non-powered contacts operated by any kind of control system.

CAUTION

If primary-side voltage is 230VAC, move black primary-side lead from transformer’s “208V” terminal to the transformer’s terminal marked “240V” (“230V” in some units). Do not move the black primary-side lead that is connected to the transformer’s “COM” terminal.

HOW TO RESET THE 24VAC CIRCUIT BREAKER

If the transformer is subjected to an excessive load or a short circuit, the circuit breaker will trip to prevent the failure of the transformer. When it trips the circuit breaker’s button pops up. Shut off the primary-side power to the unit, and remove the excessive load or the short. The circuit breaker can be reset about fifteen seconds after it trips by pressing in the button.

LIMITS OF POWER OUTPUT

If limits on wire gauge and length are observed, you may connect control devices that draw up to 8VA to the blue and red wires. More than one device can be connected as long as total steady-state load does not exceed 8VA.

OBSERVE THESE LIMITS TO WIRE LENGTH AND GAUGE
in order to ensure reliable operation of the control system.

Wire Gauge	#22	#20	#18	#16	#14	#12
Circuit Length	100'	150'	250'	400'	700'	1000'

“Circuit Length” is distance from ERV to Control Device.

INSTALLATION

CONTROL WIRING SCHEMATICS

NOTE: The simplified schematics below show only the relevant portions of the low-voltage control circuit in the ERV unit and representational external control approaches. See the complete unit schematics elsewhere in this manual.

CAUTION

Be careful if the external control system provides 24VAC power at its control output: make sure blue and red leads are separately capped and not connected to any other wires.

CONTROL WIRING EXAMPLES BY TYPE OF APPLICATION

A. Single 2-wire Control: Use this schematic if the control requires no power to operate and acts like a simple on/off switch. The control must not supply any power to the ERV unit. Connect the blue lead to one yellow lead. Connect the control's contacts to the red lead and the remaining yellow lead.

Control on separate Power Supply, no power present at Control Output:
Wire as shown for the Single 2-wire control.

CAUTION

Make sure the control provides no voltage or current at its output terminals.

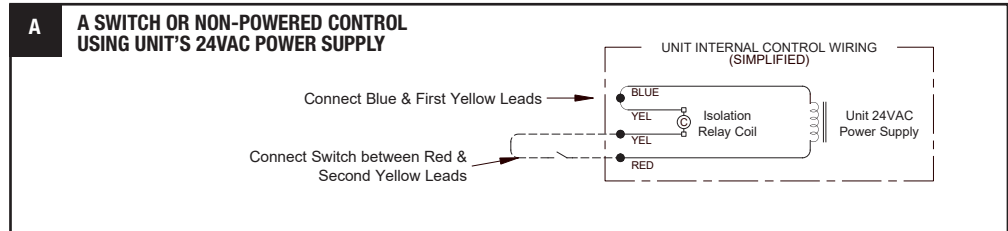

B. Control Sending 24VAC "On" Signal (from an external power source) to ERV: Make sure the blue and red leads are separately capped and not connected to any other wires. Now you safely can apply 24VAC to the two yellow leads to operate the ERV's isolation relay.

CAUTION

Supply only 24VAC (not VDC) from a Class II Power Source.

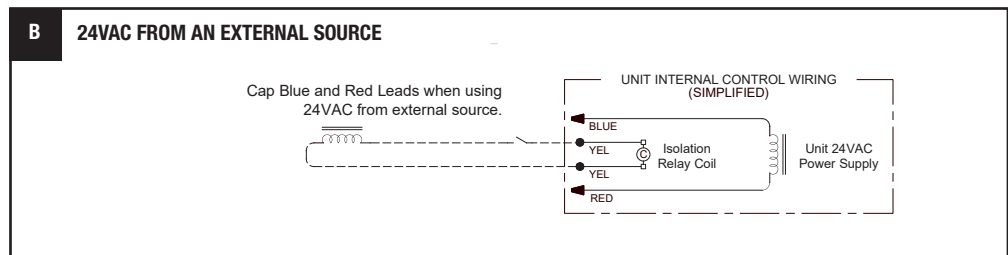

C. Control operating on Unit's 24VAC Power Supply: 24VAC power is available at the blue and red leads. Connect one of the yellow leads to the blue lead. Connect the switched output of the Control to the red lead to operate the ERV's isolation relay.

CAUTION

External control system should not draw more than 8VA.

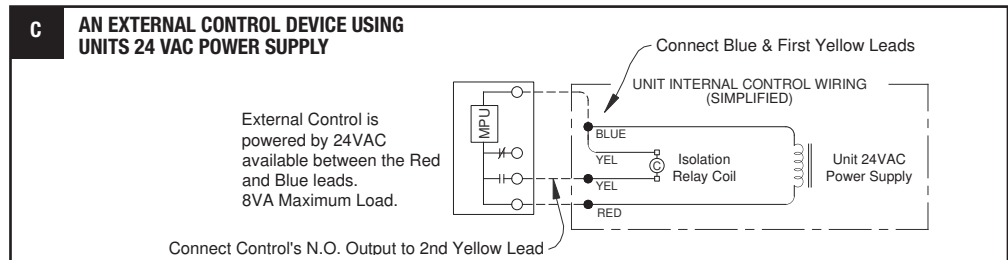

START-UP

EQUIPMENT REQUIRED

- A magnehelic gauge or other device capable of measuring 0 to 1.5 in. water of differential pressure.
- 2 pieces of natural rubber latex tubing, 1/8" ID, 1/16" Wall works the best.

NOTE: Be sure to remove cap from pressure port before inserting tubing. Insure tubing is well seated in pressure ports.

NOTE: The tubing should extend in the pressure port approx. 1 inch.

CROSS CORE STATIC PRESSURE MEASUREMENT INSTRUCTIONS

The individual differential static pressures (DSP) can be measured using the installed pressure ports located in the front of the units core access doors.

NOTE: These ports have been carefully located on the unit as to give you the most accurate airflow measurement. Do not relocate pressure ports.

- To read SCFM of Fresh Air (FA) install the "high" pressure side (+) of your measuring device to the Outside Air (OA) port and the "low" pressure side (-) to the Fresh Air (FA) port.

- To read SCFM of Room Air (RA) install the "high" pressure side (+) of your measuring device to the Room Air (RA) port and the "low" pressure side (-) to the Exhaust Air (EA) port.

- Use the reading displayed on your measurement device to cross reference the CFM output using the conversion chart.

NOTE: Be sure to replace cap into pressure port when air flow measuring is completed.

MEASURING AIR FLOW

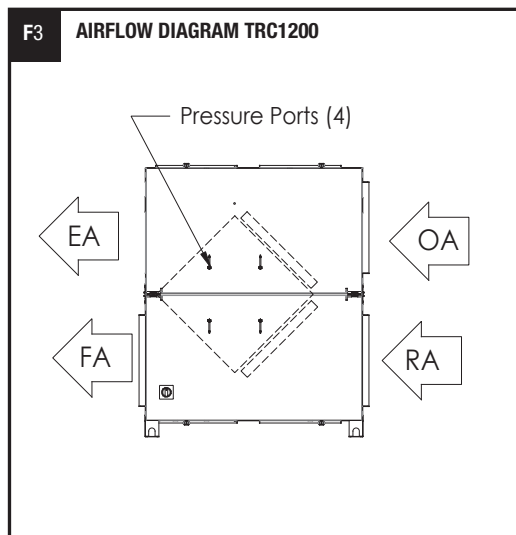

DIFFERENTIAL STATIC ACROSS CORE DSP VS. CFM

	DSP	0.15	0.20	0.25	0.30	0.35	0.40	0.45	0.5	0.55	0.60	0.65	
TRC1200	Fresh Air (FA)	CFM	380	500	620	740	860	980	1095	1215	1330	1450	1565
	Room Air (RA)	CFM	320	440	565	695	825	960	1095	1235	1375	1515	-

NOTE: Pressure drop of clean 2" MERV-8 Filters is included in the Unit Performance Ratings Table.

START-UP

MEASURING AIR FLOW

FILTER SPECIFICATIONS

- (2) 14" x 20" x 2" and (2) 16" x 20" x 2" (nominal) pleated filters. Actual size: 13.5" x 19.5" x 1.75" and 15.5" x 19.5" x 1.75".
- Optionally (4) 15" x 20" x 2" (nominal) pleated filters can be used. Actual size: 14.5" x 19.5" x 1.75"
- Unit shipped with MERV-8 Filters. Minimum recommended effectiveness: MERV-6

INITIAL PRESSURE DROP OF MERV 8 FILTERS SUPPLIED WITH THIS UNIT

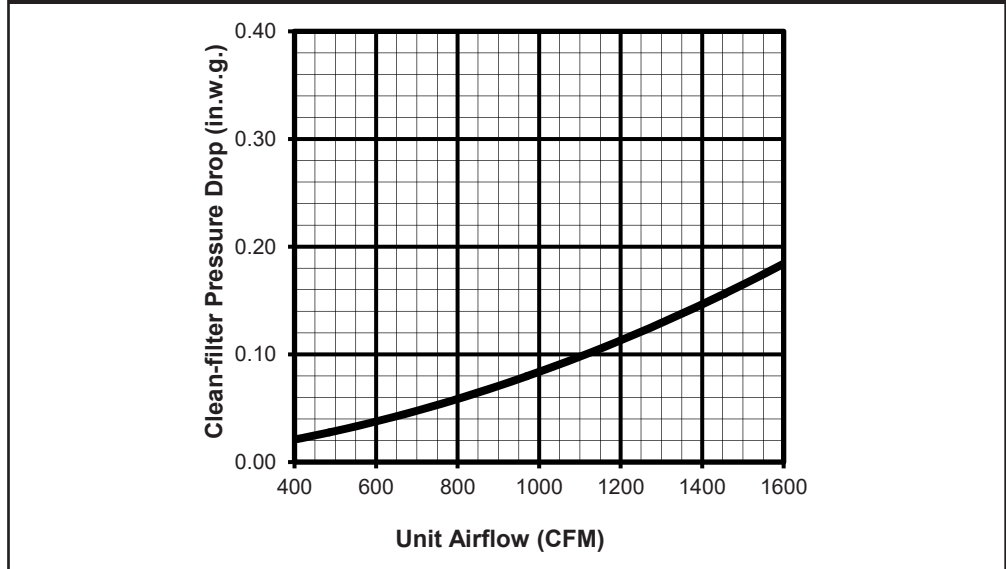

NOTES

MAINTENANCE

SERVICE PARTS TRC1200

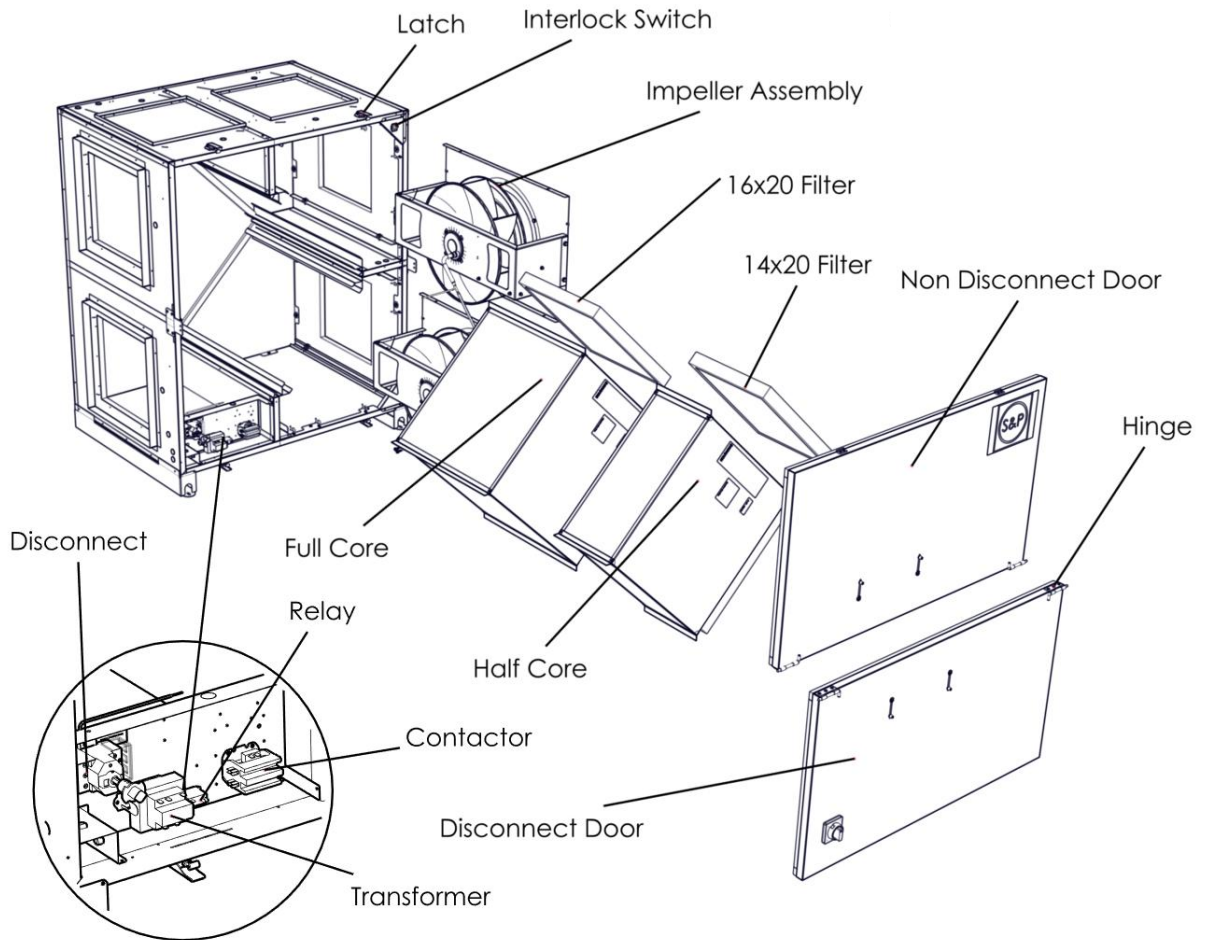

MAINTENANCE

⚠ WARNING

Danger of Electrical Shock when servicing an installed unit.

ALWAYS DISCONNECT POWER SOURCE BEFORE SERVICING! More than one disconnect switch may be required. Proper Wiring Size Selection and Wiring Installation are the Responsibility of the Electrical Contractor.

Keep your ERV performing at its best by cleaning it as described below:

TO CLEAN THE ENERGY EXCHANGE ELEMENT

Vacuum the face of the energy exchange element yearly. Dust collects only on the entering face of the energy exchange element, right where the filter sits. The interior of the energy exchange element stays clean even if the element faces are dust covered.

1. Remove the filters (see below)
2. Vacuum the exposed faces of the energy exchange element with a soft brush attachment
3. Vacuum out dust from the rest of the unit case
4. Install new filters

INSPECT AND CHANGE THE FILTERS REGULARLY.

Inspect and/or replace filters every two or three months when the TRC1200 is in regular use, or as needed. Filters must be used or the energy exchange core will become blocked by dust and the unit will not do its job. In extreme cases components may be damaged.

1. To access the filters unlatch the access doors. The access doors may be removed.
2. Pull the dirty filters out and replace with new filters.

NOTE: The filters supplied in the unit are usually able to keep the energy exchange core clear for several months. Finer filters can be used but must be cleaned more often. If using finer filters, their increased resistance to flow must be allowed for in the system design.

MOTOR MAINTENANCE

The motor needs no lubrication. If necessary vacuum clean the blower wheels at the same time you clean the face of the energy exchange element (annually).

⚠ WARNING**RISK OF INJURY OR DAMAGE.**

Motor has an automatic reset thermal protector. Disconnect power before servicing or resetting motor thermal protector. Use caution, motor may be hot. The motor must cool before it resets the thermal protector.

If the motor thermal protector tripped, correct the issue that caused the motor to overheat (e.g. over motor rated amperage or locked rotor).

REQUIREMENTS

CAUTION**DO NOT WASH THE ENERGY EXCHANGE CORE.**

Keep it away from water or fire to avoid damaging it. Always handle the core carefully.

⚠ WARNING

Don't allow the access door to drop when unlatched. Injury to personnel or damage to unit may occur.

Keep fingers away from between the access doors when unlatching and opening the doors. Potential PINCH POINT.



USA

(800) 961-7370

FAX: (800) 961-7379

6393 POWERS AVE

JACKSONVILLE, FLORIDA

32217 USA

WWW.SOLERPALAU-USA.COM

CANADA

(416) 744-1217

FAX: (416) 744-0887

5600 AMBLER DRIVE

MISSISSAUGA, ON L4W 2K9 - CANADA

WWW.SOLERPALAU-CANADA.COM