

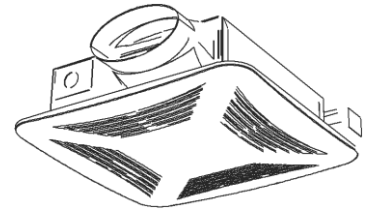

VENTILATION FAN



MODEL: PCLP80XP PCLP100XP

WARNING

TO REDUCE THE RISK OF FIRE, ELECTRIC SHOCK, OR INJURY TO PERSONS, OBSERVE THE FOLLOWING:

- Use this unit only in the manner intended by the manufacturer. If you have questions, contact the manufacturer.
- Before servicing or cleaning unit, switch power off at service panel and lock the service disconnecting means to prevent power from being switching on accidentally. When the service disconnecting means cannot be locked, securely fasten a prominent warning device, such as a tag, to the service panel.
- Installation work and electrical wiring must be done by a qualified person(s) in accordance with all applicable codes and standards, including fire-rated construction codes and standards.
- Sufficient air is needed for proper combustion and exhausting of gases through the flue (chimney) of fuel burning equipment to prevent back drafting. Follow the heating equipment manufacturer's guideline and safety standards such as those published by the National Fire Protection Association (NFPA), and the American Society for Heating, Refrigeration and Air Conditioning Engineers (ASHRAE), and the local code authorities.
- When cutting or drilling into wall or ceiling, do not damage electrical wiring and other hidden utilities.
- Ducted fans must always be vented to the outdoors.
- Acceptable for use over a tub or shower when connected to a GFCI (Ground Fault Circuit Interrupter) - protected branch circuit (ceiling installation only).
- This unit must be grounded.
- Not for Use in Kitchens.
- To reduce risk of fire and to properly exhaust air, be sure to duct air outside – Do not vent exhaust air into spaces within walls or ceilings or into attics, crawl spaces, or garages.
- The fan must not be installed in a ceiling thermally insulated to a value greater than R40.

CAUTION

- For general ventilating use only. Do not use to exhaust hazardous or explosive materials and vapors.
- This product is designed for installation in ceilings up to a 12/12 pitch (45 degree angle). Duct connector must point up.
- To avoid motor bearing damage and noisy and/or unbalanced impellers, keep drywall spray, construction dust, etc. off power unit.
- Please read specification label on product for further information and requirements.

CLEANING & MAINTENANCE

For quiet and efficient operation, long life, and attractive appearance - lower or remove grille and vacuum interior of unit with the dust brush attachment.

The motor is permanently lubricated and never needs oiling. If the motor bearings are making excessive or unusual noises, replace the motor with the exact service motor. The impeller should also be replaced.

OPERATION

Use an on/off switch to operate this fan. See "CONNECT ELECTRICAL WIRING" for details.

PLAN THE INSTALLATION

- Do not install fan above or inside a 45-degree angle projected outwards from the cooking equipment element closest to the fan. See instruction sheet for clarification.
- Two ways to connect ductwork to a factory-shipped unit.

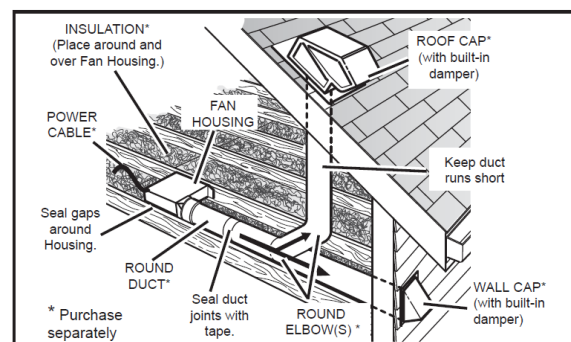
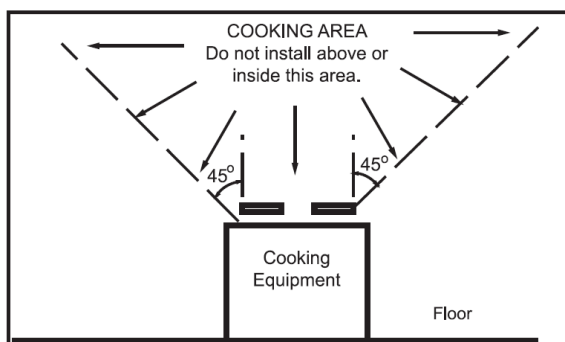

READ AND SAVE THESE INSTRUCTIONS
Installer: Leave this manual with the homeowner.

ASSEMBLY INSTRUCTIONS

1. Before installation, you need to know:

- Screw A ST4.2*13mm
- Screw B ST4.2*25mm
- Hanger bar 13 3/8 in. (340mm)



When installing contractor packs, make sure to install any optional modules such as speed controls or humidity sensors with the fan housing to ensure wiring is completed properly. Module and grille plugs come packaged with the optional accessory and must be installed with the fan housing.

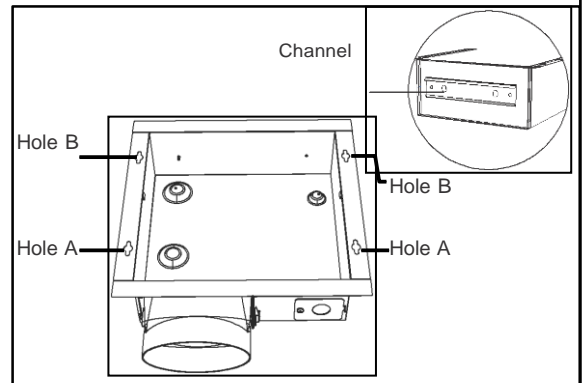

2. Mount with mounting holes

Hold housing in place so that the mounting flange contacts the bottom of the joist. Screw housing to joist through the hole A and B locations.

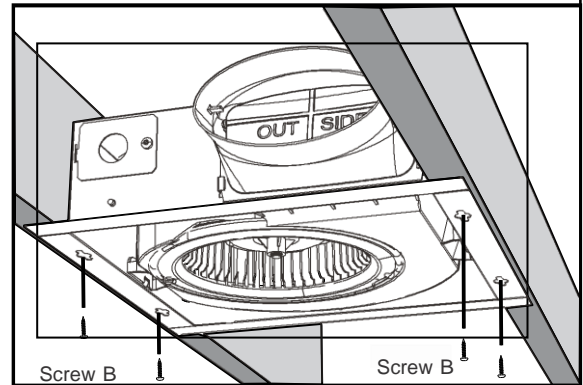

3. Mount with mounting holes

Slide one hanger bar into the channel on the housing and adjust as needed to fit between framing. Hold housing in place so that the mounting flange contacts the bottom of the joist. Screw housing to joist through the holes A and B. Screw the hanger bar onto the other side of joist through its hole.

Screw hanger bar to housing with screw A.

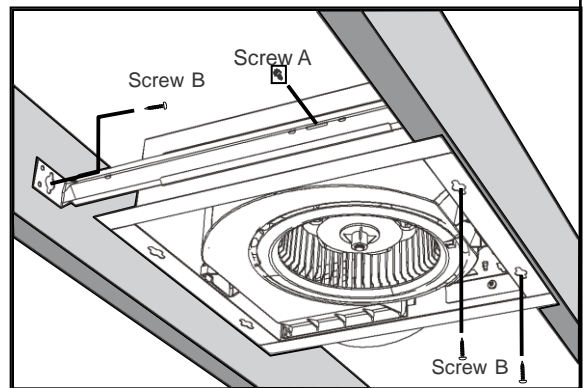

4. Mount to I-joist

Slide hanger bar into the channel on the housing and adjust as needed to fit I-joist. Hold housing in place so that the mounting flange contacts the bottom of joist. Screw housing to joist through the hole A and hole B. Screw the hanger bar onto the joist through its hole.

Screw hanger bar to housing with screw A.

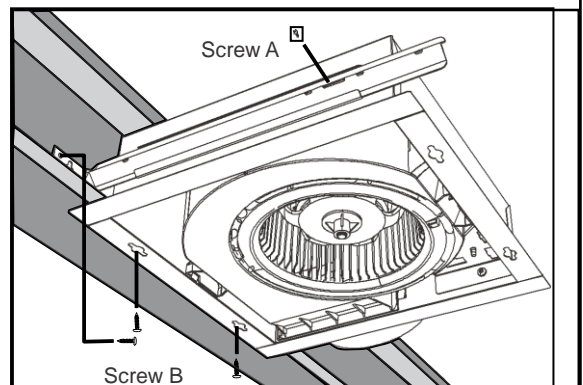

5. Wall installation

5a. When the product is installed on the wall, the adaptor shall be faced upward.

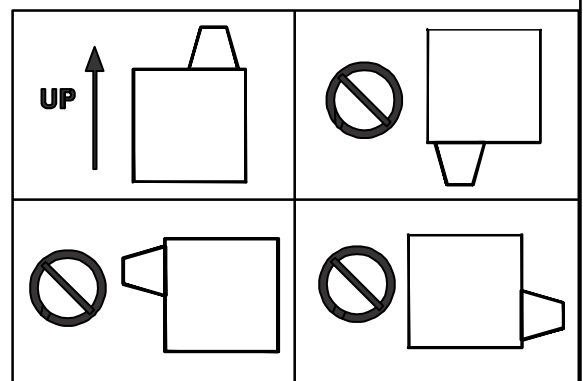

ASSEMBLY INSTRUCTIONS

- 5b. Slide hanger bar into the channel on the housing. Hold housing in place so that the mounting flange contacts the interior side of the stud. Screw housing to stud through the hole A and hole B on the same side. Screw the hanger bar onto the stud through its hole. Screw hanger bar to housing with screw A. The minimum installation distance between studs is 13 3/8 in. (340mm)

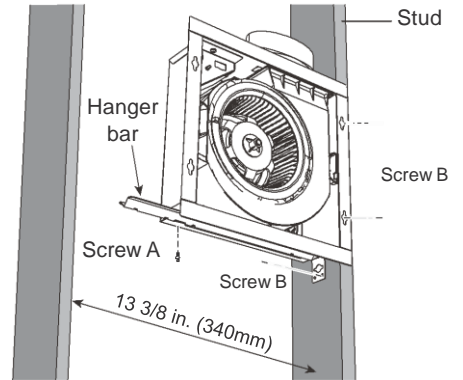

6. INSTALL ROUND DUCTWORK

Connect the round ductwork (not included) to the damper/duct connector, and run the ductwork to a roof or wall cap (not included). Using tape (not included), secure all the ductwork connections so that they are air tight.

The ducting from this fan to the outside of the building has a strong effect on the air flow, noise and energy use of the fan. Use the shortest, straightest duct routing possible for best performance, and avoid installing the fan with smaller ducts than recommended. Insulation around the ducts can reduce energy loss and inhibit mold growth. Fans installed with existing ducts may not achieve their rated air flow.

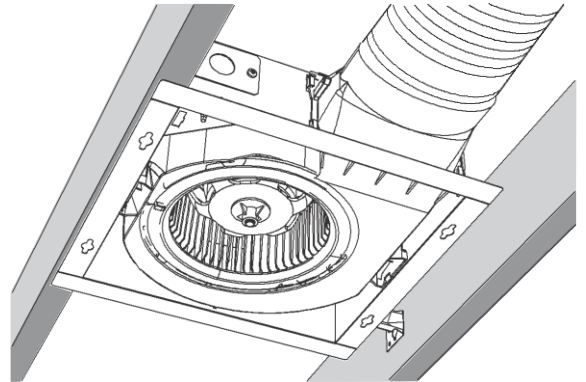

CONNECT ELECTRICAL WIRING

Run 120 VAC house wiring to the location of the fan. Use only UL-approved connectors (not included) to attach the house wiring to the wiring plate. Refer to the wiring diagram, and connect the wires as shown.

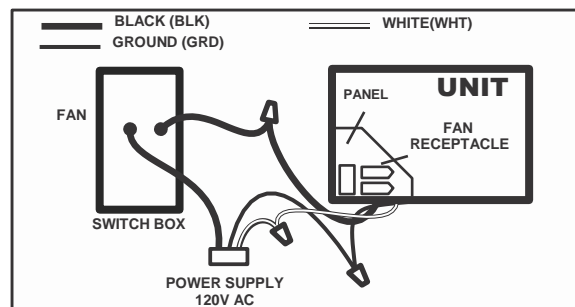
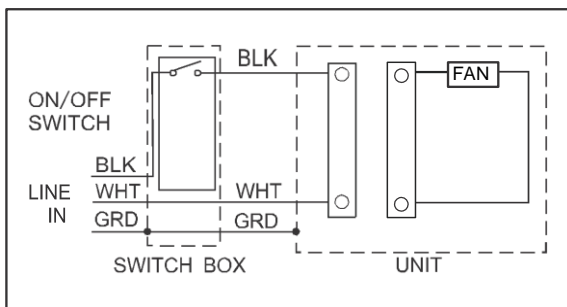

INSTALL GRILLE

Install ceiling material to complete the ceiling construction. Then, cut around the fan housing.

To attach the grille assembly to the fan housing, pinch the grille springs on the sides of the grille assembly, and position the grille into the housing with the grille springs in the appropriate slots. Push the grille assembly towards the ceiling to secure.

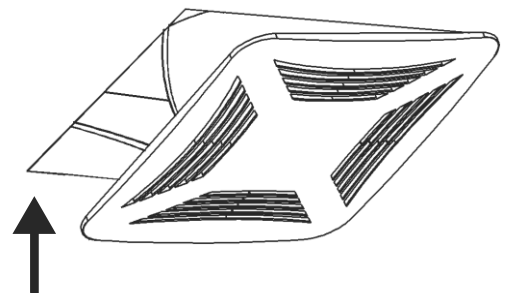

SERVICE PARTS

PART	PART NAME	Qty.
1	Grille Assembly (includes part 2)	1
2	Grille Spring	2
3	Blower	1
4	Blower Wheel	1
5	Motor	1
6	Motor plate	1
7	Wire Panel / Harness Assembly	1
8	Housing	1
9	Wiring plate	1
10	Damper / Duct Connector	1
11	Hanger Bar	1
a	Screw	3
b	Screw	3
c	Screw	3
d	Screw	1
e	Screw	1
f	Screw	1

* Blower Assembly includes part 3, 4, 5, 6, b, c.

* Replacement part are shown for illustration purposes only and are not sold separately

WARNING: Before replacing, be sure to turn off power at power source.

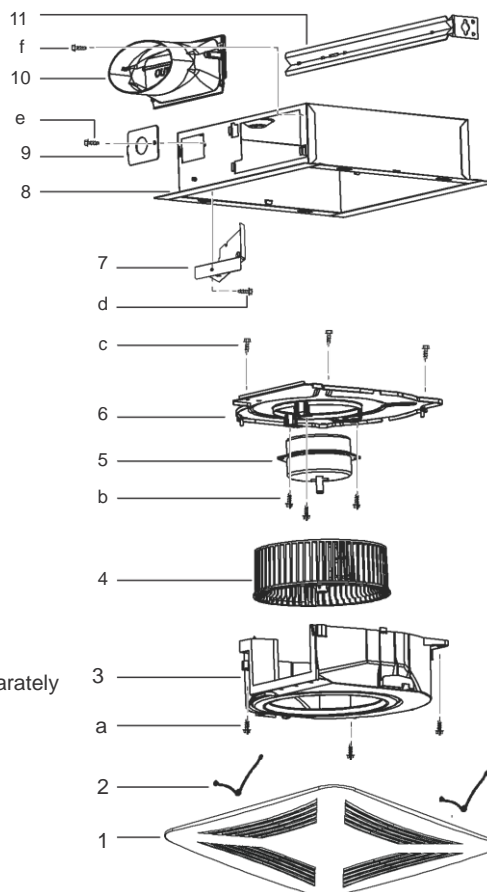

WARRANTY

S&P USA Ventilation Systems, LLC. & S&P Canada Ventilation Products, Inc. warrants to the original end user of its products that our exhaust fans will be free from defects in materials and workmanship for a period of Five (5) years from the date of original purchase. THERE ARE NO OTHER WARRANTIES, EXPRESSED OR IMPLIED, INCLUDING BUT NOT LIMITED TO IMPLIED WARRANTIES OF SUITABILITY FOR A PARTICULAR PURPOSE.

During this five year period, S&P will, at its option, repair returned products or parts, or provide replacement products or parts, without charge, for any product or part which is found to be defective under normal use.

This warranty does not cover normal maintenance and service or any parts that have been subject to misuse, negligence, accident, improper maintenance or repair, faulty installation or installation contrary to recommended installation instructions.

S&P's obligation to repair or replace, at S&P's option, shall be the purchaser's sole and exclusive remedy under this warranty. No labor or materials are covered by this warranty. S&P shall not be liable for incidental damages arising out of or in connection with product use or performance.

This warranty gives you specific legal rights. You may also have other rights which vary from state to state.

To qualify for warranty service, you must notify S&P at the address or telephone number stated below, provide the model number and part identification, and describe the nature of any defect in product or part. You may be required to ship a defective part to S&P. There will be no charge for shipping repaired or replacement parts from S&P to you if your address is in the United States or Canada. At the time of requesting warranty service, you must present evidence of the original purchase date.



**ADVANCING
VENTILATION®**

S&P USA Ventilation Systems, LLC.

6393 Powers Avenue Jacksonville, FL 32217

P. 904-731-4711

F. 904-737-8322

www.solerpalau-usa.com

S&P Canada Ventilation Products, Inc.

6710 Maritz Drive Unit #7 Mississauga, ON L5W 0A1 - Canada

T. 416-744-1217

F. 416-744-0887

www.solerpalaucanada.com