



SET - SETU Series

&

ITT - ITTU Series

TWO-STAGE LOW INTENSITY TUBE TYPE INFRARED HEATERS

For Indoor Use



INSTALLATION / OWNER'S MANUAL



WARNING Improper installation, adjustment, alteration, service or maintenance can cause property damage, injury or death.
Read the installation and operating and maintenance instructions thoroughly before installing or servicing this equipment.

SAFETY ALERT:



This heater must be installed and serviced only by a trained gas service technician. Failure to comply could result in personal injury, death, fire and/or property damage.

Do not store or use gasoline or other flammable vapours and liquids in the vicinity of this or any other gas fired appliance.



IF YOU SMELL GAS:

- Extinguish any open flame
- Do not attempt to light this or any other appliance
- Don't touch any electrical switch, or telephone
- Immediately call your gas supplier from a neighbor's phone
- Follow any and all instruction from your gas supplier
- If your gas supplier is not available, call the fire department



FIELD CONVERTIBILITY:
This appliance is field convertible to Propane.

Keep this manual in a secure place.
Record for future reference:

Model #: _____

Serial #: _____

(located on heater rating label)



NOTICE:

This manual is current for the product with which it is packaged. Occasional revision of the product Certification Standard and/or Codes may require changes to the product and/or this manual.

This publication, or parts thereof, may not be reproduced in any form, without prior written consent from The Manufacturer. Unauthorized use or distribution of this publication is strictly prohibited.

Schwank

Schwank and InfraSave brands

5285 Bradco Boulevard

Mississauga, Ontario, L4W 2A6

PO Box 988, 2 Schwank Way

Waynesboro, Georgia 30830

Customer & Technical Services

Phone: 877-446-3727 OR 706-554-6191

Fax: 866-361-0523

e-mail: csr@schwankgroup.com

www.schwankgroup.com

www.infrasave.com

SET / SETU and ITT / ITTU SERIES GAS FIRED INFRARED LOW INTENSITY TUBE TYPE

TABLE OF CONTENTS

TOPIC PAGE	TOPICPAGE
<u>IMPORTANT INFORMATION - READ FIRST</u>			
APPLICATION	4	14. ELECTRICAL AND THERMOSTAT	32
HEATER EXPANSION	5, 31	15. HIGH ALTITUDE INSTALLATION.....	32
GAS CONNECTION	5, 31	16. LIGHTING INSTRUCTIONS	32
VENTING	5, 26	17. RECOMMENDED MAINTENANCE	32
START UP 'SMOKE'	5	18. WIRING DIAGRAM: FENWAL DSI 2-STAGE 24 VOLT THERMOSTAT	33
THERMOSTAT SETTING / COMFORT	5	19. WIRING DIAGRAM MULTIPLE HEATERS PER 2-STAGE THERMOSTAT	34
TUBE 'GLOW'	6	20. FENWAL DSI: SEQUENCE OF OPERATION	35
CLEARANCE TO COMBUSTIBLES	6	SPARK IGNITER ADJUSTMENT	37
Clearances Figure & Table	7	21. TROUBLESHOOTING GUIDE: FENWAL DSI.....	38
STACKING HEIGHT SIGN	8	22. TROUBLESHOOTING GUIDE: HEATER	39
1. LABOR REQUIREMENTS	9	23. START- UP / COMMISSIONING SHEET	41
2. INSTALLATION IN AIRCRAFT HANGARS	9	<u>PRODUCT DIMENSIONS & DATA</u>	
3. INSTALLATION IN COMMERCIAL GARAGES.....	9	24. HEATER DIMENSIONS / WEIGHTS	43
4. INSTALLATIONS OTHER THAN SPACE HEATING	9	INSTALLATION DIMENSIONS	44
5. PRE-INSTALLATION SURVEY	10	25. BURNER / TUBE KIT ASSEMBLY CHART STRAIGHT TUBE SYSTEM	45
6. MOUNTING CLEARANCES	11	'U' TUBE SYSTEM	46
SERVICE CLEARANCE.....	11	26. TURBULATORS	47
HEATER PLACEMENT GUIDELINES	12	TURBULATOR ILLUSTRATION	48
7. SYSTEMS WITH 90° & 180° ELBOWS	12	27. HIGH ALTITUDE & ORIFICE CHART	49
ELBOW KIT DIMENSIONS	13, 50	28. OPTIONAL ACCESSORIES	50 - 53
8. SUSPENDING THE SYSTEM.....	14	29. BURNER PARTS LIST	54 - 56
9. BURNER & TUBE INSTALLATION STRAIGHT TUBE SYSTEM.....	15	30. TUBE SYSTEM PARTS LIST	57-58
'U' TUBE SYSTEM.....	17	WARRANTY STATEMENT	BACK PAGE
SPECIAL COUPLING - 175 & 200 Mbh	19		
10. REFLECTOR INSTALLATION	20		
11. FLUE VENTING	22		
12. COMBUSTION AIR DUCT	28		
13. GAS SUPPLY	29		
HEATER EXPANSION	30		
FLEXIBLE GAS CONNECTION.....	31		



WARNING

Improper installation, adjustment, alteration, service or maintenance can cause property damage, injury or death. Read and understand this installation and operation manual thoroughly prior to assembly, installation, operation or service to this appliance.



This heater must be installed and serviced only by a trained gas service technician.



Do not store or use gasoline or other flammable vapours and liquids in the vicinity of this or any other gas fired appliance.



Failure to comply could result in personal injury, death, fire and/or property damage.

Do not store or use gasoline or other flammable vapours and liquids in the vicinity of this or any other gas fired appliance.

This appliance may have sharp edges and corners. Wear protective clothing such as gloves and protective eye wear when servicing this or any other appliance.

California Proposition 65:



WARNING: This product can expose you to chemicals including carbon monoxide, which is known to the State of California to cause birth defects or other reproductive harm. For more information, go to www.P65Warnings.ca.gov

APPLICATION

A gas-fired radiant tube heater may be installed for heating of commercial / industrial non-residential spaces. It is beyond the scope of these instructions to consider all conditions that may be encountered. Installation must conform with all local building codes or, in the absence of local codes, with the National Fuel Gas Code, ANSI Z223.1/NFPA 54 in the U.S.A. or the Natural Gas and Propane Installation Code, CSA B149.1 in Canada. The latest edition Electrical Code ANSI/NFPA N0 70 in the U.S.A. and PART 1 CSA C22.1 in Canada must also be observed.

Installation of a gas fired tube heater must conform to all heating installation design procedures including clearance to combustibles, connection to the gas and electrical supplies, and ventilation.

This heater is not for installation in a Class 1 or Class 2 explosive environment, nor a residence. If installation of this equipment is in question, consult with local authorities having jurisdiction (Fire Marshall, labor department, insurance underwriter, or others).

Revisions to codes and/or standards, may require revision to equipment and installation procedures. In case of discrepancy, the latest codes, standards, and installation manual will take priority over prior releases.

Models SET and ITT may be installed for two stage heating of commercial / industrial non-residential **indoor spaces**.

MODELS AVAILABLE FOR OTHER APPLICATIONS:

Models SETW / ITTW (two stage) and **SPW-JZ / IWP** (single stage) have a powder coated water resistant burner enclosure and may be installed for heating of commercial / industrial non-residential **outdoor spaces and wet indoor environments**.

Models STW-JZ and IW have a stainless steel water resistant burner enclosure and may be installed for heating of commercial / industrial non-residential **outdoor spaces and harsh wet indoor environments**.



WARNING

Heater Expansion



It is a normal condition that during heat-up and cool-down a tube heater will expand and contract. Allowances for heater expansion must be made in the gas connection, venting and combustion air ducting. Improper installation, alteration, or adjustment can result in property damage, injury or death. **Refer to Section 13**



WARNING

Gas Connection



Improper installation, connection, or adjustment can result in property damage, toxic gases, asphyxiation, injury or death. Using an approved flexible gas connector in the USA or Type 1 hose connector in Canada, the gas supply to the heater must be connected and tested in accordance with all local, state, provincial, and national codes (ANSI Z223.1/NFPA 54 in USA; B149.1 in Canada) and as indicated in this manual. **Refer to Section 13**



WARNING

Venting



Inadequate venting of a heater may result in asphyxiation, carbon monoxide poisoning, injury or death. This heater may be directly or indirectly vented from the space. Venting must be in accordance with all local, state, provincial, and national codes (ANSI Z223.1/NFPA 54 in USA; B149.1 in Canada) and as indicated in this manual.



WARNING

Start-Up 'SMOKE' Condition

During start up, the heating of material coatings used in the production process of tubes and reflectors will create smoke during the initial period of operation. This condition is normal and temporary .

Ensure that there is sufficient ventilation to adequately clear any smoke from the space.

Notify site and safety personnel to ensure that alarm systems are not unduly activated.



IMPORTANT

THERMOSTAT SETTING FOR COMFORT

Infrared radiant (IR) heating system provide comfort with the effect of radiant heat and ambient air heat.

If your IR system is controlled with a TruTemp or ThermoControl Plus controller that senses radiant heat, then set the control to the desired comfort temperature (ie: 65°; 68°; 20°C).

If your IR system is controlled with a standard 24V or 120V thermostat that senses only air temperature, then start with a thermostat setting that is 5° to 7°F (3° to 5°C) lower than the desired comfort temperature. Some trial and error setting may be required to 'fine tune' the comfort temperature that best suits the site and provides most economical operation.

Unoccupied (night) set-back of 9°F (5°C) is recommended. Do not turn the system 'Off'.



WARNING

Tube “GLOW”

It is a normal condition that the combustion tube (1st tube) can appear to “glow red”. For inputs up to 150,000 Btuh, the top surface of the tube can appear red where heat is trapped between the reflector and the tube. The stainless steel tube used for inputs 175,000 and greater can appear to entirely glow red. The tube material is designed into the heater because it can withstand the high temperature of combustion, and the “red glow” is a normal occurrence.



WARNING

Clearance to combustibles

Location of flammable or explosive objects, liquids or vapors close to the heater may cause fire or explosion and result in property damage, injury or death. Do not use, store or locate flammable or explosive objects, liquids or vapors in proximity of the heater.



The clearance to combustible material represents the minimum distance that must be maintained between the outer heater surface and a nearby surface. The stated clearance to combustibles represents a surface temperature of 90F° (50C°) above room temperature. It is the installer’s responsibility to ensure that building materials with a low heat tolerance which may degrade at lower temperatures are protected to prevent degradation. Examples of low heat tolerance materials include vinyl siding, fabrics, some plastics, filmy materials, etc.

In locations used for the storage of combustible materials, signs must be posted to specify the maximum permissible stacking height to maintain the required clearances from the heater to the combustibles. Such signs must either be posted adjacent to the heater thermostats or in the absence of such thermostats in a conspicuous location. In addition to stored or stationary material, consideration must also be given to moveable objects such as cranes, vehicles, and overhead doors, and structural objects such as sprinkler heads, electrical and gas lines, and electrical fixtures.

It is beyond the scope of these instructions to consider all conditions that may be encountered. Consult local authorities such as the Fire Marshall, insurance carrier, or safety authorities if you are uncertain as to the safety or applicability of the proposed installation.

Refer to Figure 1 and Table 1 for the certified clearances to combustibles for the appropriate model input/size.

FIGURE 1 MINIMUM CLEARANCES TO COMBUSTIBLES* - refer to Table 1 for values

NOTE: A 'PEEL & STICK' SIGN IS SUPPLIED: USE AN INDELIBLE MARKER TO ENTER VALUES 'H', 'S', 'F', & 'B' ON .
 POST THE SIGN ADJACENT TO THE HEATER THERMOSTAT OR IN A PROMINENT LOCATION. See next page for details.

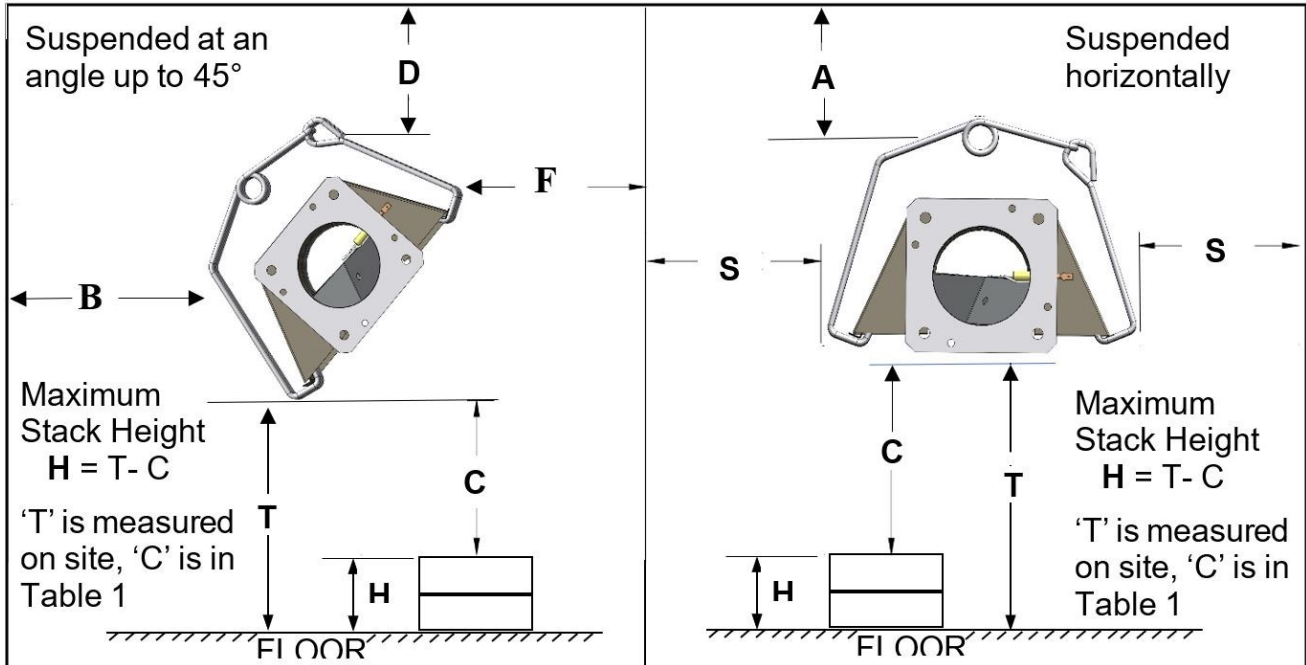

TABLE 1 MINIMUM CLEARANCES TO COMBUSTIBLES*

MODEL SET(U) / ITT(U) "Straight" & "U-Tube"	HORIZONTAL			ANGLE UP TO 45 DEGREES			
	TOP	SIDE	BELOW	TOP	REAR	FRONT	BELOW
	A inches (cm)	S inches (cm)	C inches (cm)	D inches (cm)	B inches (cm)	F inches (cm)	C inches (cm)
200,000/140,000	7"	22"	68"	7"	1"	57"	68"
175,000/125,000	6.5"	20"	68"	6.5"	1"	47"	68"
155,000/110,000	6"	19"	64"	6"	1"	44"	64"
130,000/90,000	4"	11"	60"	5"	1"	35"	56"
110,000/75,000	3"	10"	60"	4.5"	1"	26"	54"
80,000/60,000	2.5"	6"	42"	3.5"	1"	23"	38"

***NOTE: Clearances are measured from the reflector.**

The clearance to combustible materials represents the minimum distance that must be maintained between the heater and a nearby surface. **The stated clearance to combustibles represents a surface temperature of 90F° (50C°) above room temperature.**

It is the installer's responsibility to ensure that building materials with a low heat

tolerance which may degrade at lower temperatures are protected to prevent degradation. Examples of low heat tolerance materials include vinyl siding, fabrics, some plastics, filmy materials, etc.

VENT END CLEARANCE: Clearances from the vent pipe are determined by local or national installation codes, but must not be less than 6 inches For ‘unvented’ installation, a minimum distance of 24 inches is required from the end of heater to a combustible surface.



WARNING

In locations used for the storage of combustible materials: **Signs must be posted** specifying the *maximum permissible stacking height* to maintain the required clearances from the heater to the combustibles.

The signs must be posted either adjacent to the IR heating system thermostats or in the absence of such thermostats, in a conspicuous place.

For your convenience a “peel and stick” sign is provided with this heater. Use a permanent marker to record the required dimensions on the sign.

To calculate the value ‘H’: $(H = T - C)$

- Measure the on site distance between bottom of the heater and the floor = ‘T’ inches (cm).
- Refer to Table 1 to get the value ‘C’ that corresponds to the model you are installing
- Subtract the clearance below the heater ‘C’ from ‘T’ to get value ‘H’.
- Enter this value ‘H’ on the sign.

Refer to the information for the heater model being installed in Figure 1 and Table 1 to get the values for dimensions ‘S’, ‘F’ and ‘B’.

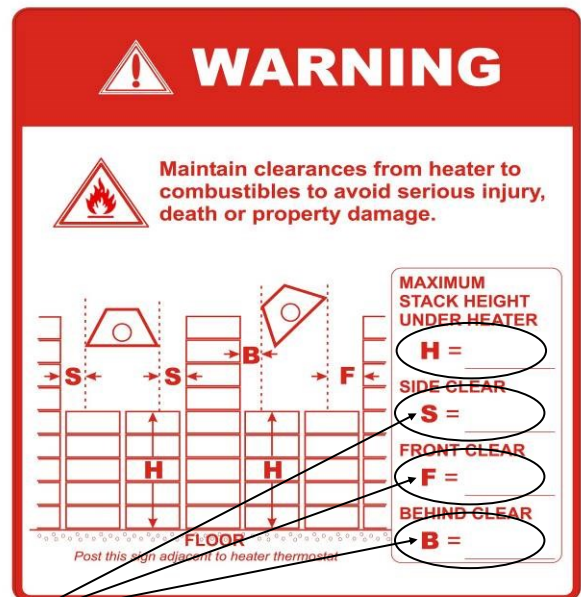

Post this sign as instructed above.

1. LABOR REQUIREMENTS

Two persons are required to safely install this equipment. Wear gloves and other required safety protection.

2. INSTALLATION IN COMMERCIAL AIRCRAFT HANGARS

Low intensity radiant tube heaters are suitable for use in aircraft hangars when installed in accordance with the latest edition of the Standard for *Aircraft Hangars*, ANSI/NFPA No 409 in the USA, or the Canadian *Natural Gas and Propane Installation Code*, B149.1.

- A. A minimum clearance of 10 ft above either the highest fuel storage compartment or the highest engine enclosure of the highest aircraft which may occupy the hangar. The clearance to the bottom of the heater shall be measured from the upper surface of either the fuel storage compartment or the engine enclosure, whichever is higher from the floor.
- B. A minimum clearance of 8 ft must be maintained from the bottom of the heater to the floor in other sections of the aircraft hangar, such as offices and shops, which communicate with areas for servicing or storage. Refer to Section 1 for proper mounting clearances to combustibles.
- C. Heaters must be located so as to be protected from damage by aircraft and other objects, such as cranes and movable scaffolding.
- D. Heaters must be located so as to be accessible for servicing and adjustment.

3. INSTALLATION IN COMMERCIAL GARAGES AND PARKING STRUCTURES

Low Intensity Heaters are suitable for use in commercial garages when installed in accordance with the latest edition of the Standard for *Parking Structures*, ANSI/NFPA 88A, or the Standard for *Repair Garages*, ANSI/NFPA No. 88B, or the Canadian *Natural Gas and Propane Installation Code*, B149.1.



WARNING

An overhead heater shall be located high enough to maintain the minimum distance to combustibles, as shown on the heater rating plate, from the heater to any vehicles parked below the heater.

Overhead heaters shall be installed at least 8 ft above the floor.

4. INSTALLATIONS OTHER THAN SPACE HEATING

Use for process or other applications that are not space heating will void the C.S.A. certification and product warranty. Process application requires field inspection and/or certification by local authorities having jurisdiction.



WARNING



Improper installation, adjustment, alteration, service or maintenance can cause property damage, injury or death. Read and understand this installation and operation manual thoroughly prior to assembly, installation, operation or service to this appliance.



This heater must be installed and serviced only by a trained gas service technician.

Do not store or use gasoline or other flammable vapours and liquids in the vicinity of this or any other gas fired appliance.



Failure to comply could result in personal injury, death, fire and/or property damage.

Do not store or use gasoline or other flammable vapours and liquids in the vicinity of this or any other gas fired appliance.

5. PRE INSTALLATION SURVEY

It is recommended that a full heating design including heat loss calculation be conducted on the structure or area to be heated. Heater sizing and placement must consider available mounting height, sources of greatest heat loss, and the certified clearances to combustibles with respect to stored material, moveable objects (cranes, vehicles, lifts, overhead doors, etc), sprinkler system heads, and other obstructions on the site. Consideration must also be given to vent / duct placement and the allowable combined lengths of vent and duct. Carefully survey the area to be heated, and for best results place burner and combustion chamber in the coldest area(s) .

Installation must conform with all local, state, provincial and national code requirements including the current latest edition ANSI Z223.1 (NFPA 54) in the U.S.A. and B149.1 installation code in Canada, for gas burning appliances and equipment. The latest edition Electrical Code ANSI/NFPA N0 70 in the U.S.A. and PART 1 CSA C22.1 in Canada must also be observed.

The heating system must have gas piping of the correct diameter, length, and arrangement to function properly. For this reason, a layout drawing is necessary.

6. MOUNTING CLEARANCES

This heater must be mounted with at least the minimum clearances between the heater and combustibles as shown in FIG.1, TABLE 1. It is the installer's responsibility to ensure that building materials with a low heat tolerance which may degrade at lower temperatures are protected to prevent degradation. Examples of low heat tolerance materials include vinyl siding, fabrics, some plastics, filmy materials, etc.

Positioning of lights, sprinkler heads, overhead doors, storage areas, gas and electrical lines, parked vehicles, cranes and any other possible obstruction or hazard must be evaluated prior to installation.

Ensure adequate clearance around the air intake at the burner to allow sufficient combustion air supply to the heater.

6A. SERVICE CLEARANCE: The lower 'jaw' of the burner cabinet swings down to provide convenient service access to burner components. Provide a minimum clearance from any wall or obstruction of 6 inches to the access end of the burner housing, and a minimum of 24 inches to any ONE side to allow servicing of burner, blower and controls. (see Figure 2) - the minimum clearances to combustibles must always be maintained.

For guidelines to heater placement refer to TABLE 2 (below).

FIGURE 2

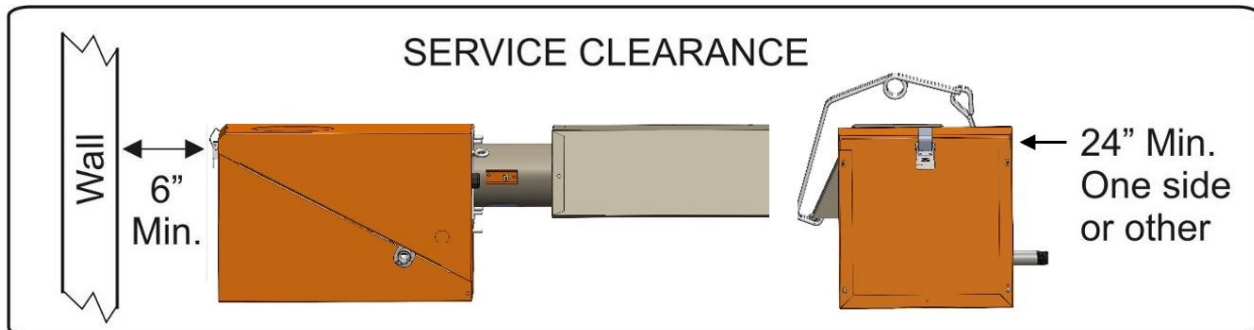



TABLE 2: GUIDELINES FOR HEATER PLACEMENT

MODEL “Straight” or “U-Tube”	GUIDELINE MOUNTING HEIGHT ft (m)	MAXIMUM DISTANCE BETWEEN HEATERS ft (m)	DISTANCE – OUTSIDE WALL TO HEATER LONG AXIS (PARALLEL TO WALL) IN “FEET”	
			HORIZONTAL ft (m)	ANGLE
SET / ITT 200/140	18 – 25	50	17 – 25	MINIMUM = COMBUSTIBLE CLEARANCE BEHIND (refer to Table 1)
SET / ITT 175/125	18 – 25	50	17 – 25	
SET / ITT 155/110	16 – 21	45	15 – 20	
SET / ITT 130/90	15 – 21	40	15 – 20	
SET / ITT 110/75	13 – 19	35	13 – 18	
SET / ITT 80/60	10 – 16	30	12 – 16	

- * GUIDELINE MOUNTING HEIGHTS are typical to provide optimum comfort in general space heating applications. Variance to these typical heights can occur in some applications:
- Higher mounting heights due to structure or application requirements
 - Lower mounting heights for area or ‘spot’ heat, or in areas with greater infiltration losses (near overhead doors, etc)



IMPORTANT: Single or multiple heater placement must be such that continuous operation of heater(s) will not cause combustible material or materials in storage to reach a temperature in excess of the ambient temperature in the space **plus** 90F° (50C°).

It is the installer’s responsibility to ensure that building materials with a low heat tolerance which may degrade at lower temperatures are protected to prevent degradation. Examples of low heat tolerance materials include vinyl siding, fabrics, some plastics, filmy materials, etc.

Refer to “Clearance to Combustibles” information on pages 6 to 8, and Figure 1 and Table 1.

7. SYSTEMS INCORPORATING 90° ELBOWS AND 180° ELBOWS

The radiant tube heater can be installed in configurations as illustrated in FIGURE 4. (below) with a maximum of two 90° elbows per heater. The use of elbows reduces the total maximum vent allowable. (See Section 11 : Flue venting)

90° elbows (JS-0528-SM) are shipped as a kit with one coupler, and two reflector end caps.

The SET / ITT is available in a “U-Tube” model - SETU / ITTU - using a 180° turn box. A double wide reflector covers the double tube run. Alternately, for a 180° elbow, order 2 x 90° kits that connect to create a 180°.



IMPORTANT: Elbow Location / Input: A minimum run of straight radiant tube must be connected to the burner before any elbow as follows: Inputs 200 (60 kW) and 175 Mbh (50 kW) = 25 ft (7.6 m); Input 155 Mbh (45 kW) = 20 ft (6 m); Inputs 130 Mbh (38 kW) and 110 Mbh (32 Kw) = 15 ft (4.6 m); and Input 80 Mbh (23 kW) a minimum of 10 ft (3 m) straight tube before elbow.

FIGURE 3 SYSTEM ELBOW KIT

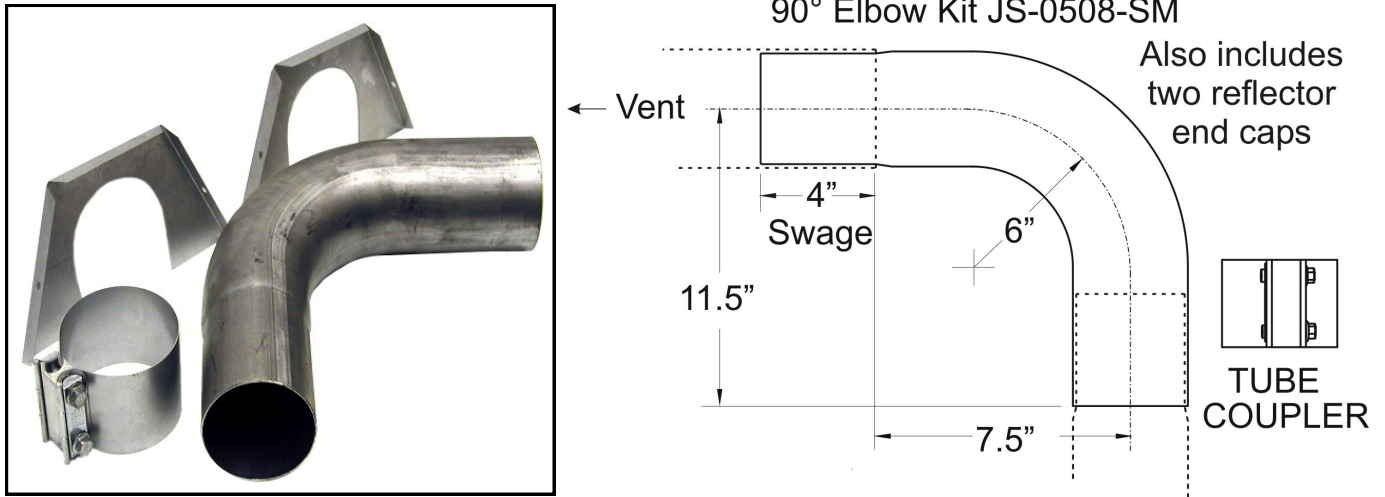
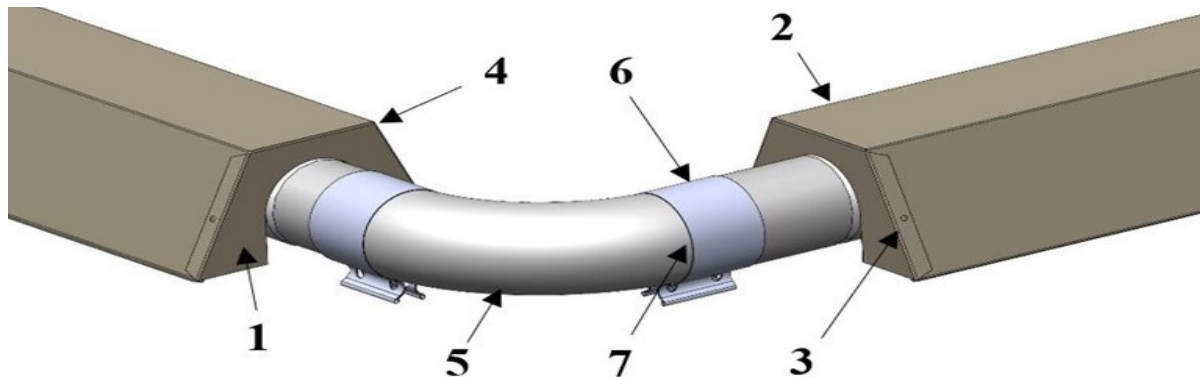

FIGURE 4 90° ELBOW INSTALLATION



- | | |
|---|--|
| 1 End-Cap | 5 90° Elbow |
| 2 Reflector | 6 Tube Coupler |
| 3 End Cap Flange <u>OVER</u> Reflector | 7 Unswaged end of elbow and tube (swage of previous tube or elbow inserted). |
| 4 End Cap Flange <u>UNDER</u> Reflector | |

8. SUSPENDING THE SYSTEM - GENERAL



Inadequate or improper suspension of the tube heater can result in collapse of the system, property damage, and personal injury or death.

It is the installer's responsibility to ensure that the hardware and structural supports from which the heater is suspended are sound and of adequate strength to support the weight and expansion forces of the heater.

Consider that the heater will expand in length as much as 1/2 inch or more for every 10 ft of system length – typically the greater the firing rate, the greater the expansion.

Refer to Sections 13 & 14

- 1) Survey the available structural supports, considering the system configuration and heat requirements of the area to establish the optimum heater location.
 - a) Locating a heater directly under joists or beams, or installing supplemental steel support rail or angle iron can substantially reduce labor and materials
- 2) Hardware with a minimum 60 lb. (30 kg) work load must be used at each heater suspension point. A #8 Jack Chain or equivalent is typically used for suspending the heater.
 - a) Connect to the structure using typical hardware as illustrated in FIGURE 6 (below) or by other mechanically sound means
 - b) If rigid devices such as 3/8" threaded rods are used for suspension, swing joints or other means must be provided to allow for system expansion - approximately 1/2 inch to 1 inch for every 10 ft of system length.
- 3) Tube system hangers must be located:
 - i: Straight in line
 - ii: At a common height (level)

NOTE: It is important that the tubes in the system are installed in alignment horizontally (level) and vertically (in line) – this will ensure system integrity

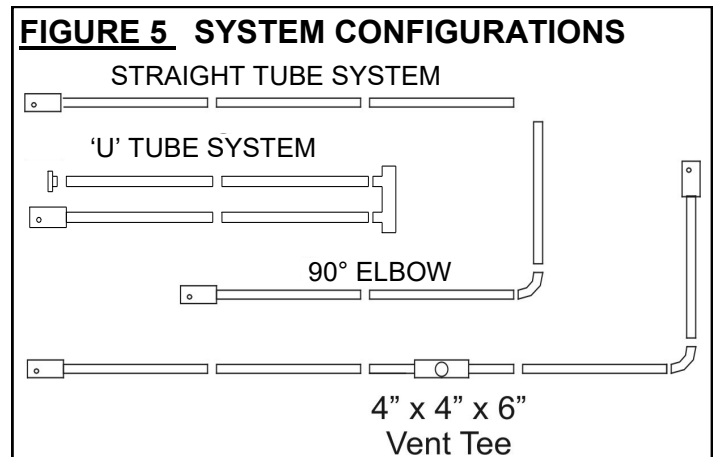
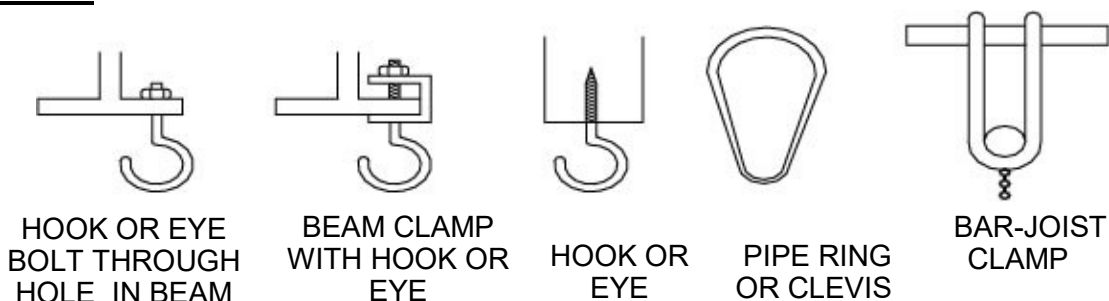

FIGURE 6 TYPICAL MOUNTING HARDWARE



NOTE: It is the installer's responsibility to ensure that mounting hardware and fastening to structure are of sufficient strength to support the system.

9 INSTALLATION OF HANGERS, TUBES AND BURNER

TURBULATOR NOTES:

- See Section 26, for details on turbulator sizes and location in system
- **Prior to Installation:**
 - **80 / 60 x 30 ft:** Remove and discard 60" turbulator from the second tube
 - **200 / 140 x 60 ft :** Remove and discard 40" turbulator from the upstream end of last tube

9.1 SET / ITT STRAIGHT TUBE SYSTEM ~ BURNER AND TUBE INSTALLATION

- 1) Install Hangers in alignment and suspended at the same height:
 - i: No closer than 3" and no further than 5" from the burner/tube flange
 - ii: Between 6" and 24" either side of a tube connection in the system
- 2) Install first aluminized tube section on to first two wire hangers.

NOTE: INSTALL THE FIRST AND SECOND TUBES (FROM BURNER END) WITH THE WELDED SEAM ALONG THE TUBE LENGTH FACING DOWNWARD
- 3) **FLAME RECTIFIER:** Remove & retain sight glass (2 screws), then install Flame Rectifier into the flanged end of first tube (Flame Rectifier **not required for SET/ITT-80/60**), See Fig. 8A.
- 4) Bolt burner to flange on first tube section, Fig. 8B. Install igniter in first tube, Fig. 8A.

IMPORTANT NOTE: Models with inputs 175,000 & 200,000 refer to section 9.3
- 5) Slide a Torctite tube coupler over the swaged end of the first tube, then join the second tube over the swage in the first tube
- 6) Slide the Torctite coupler into position across the center of the joint - SEE FIGURE 9
- 7) **IMPORTANT: TOURQUE THE COUPLER BOLTS TO 40 ft-lbs**
- 8) Subsequent lengths of tube can then be installed, by joining them together swaged portion inside the next tube and locking the joints using the Torctite coupler. SEE FIGURE 9.
- 9) If there is a 90° elbow in the system refer to Section 7 and Figures 3 & 4

FIGURE 7: STRAIGHT TUBE TYPICAL HANGER & SUPPORT SPACINGS

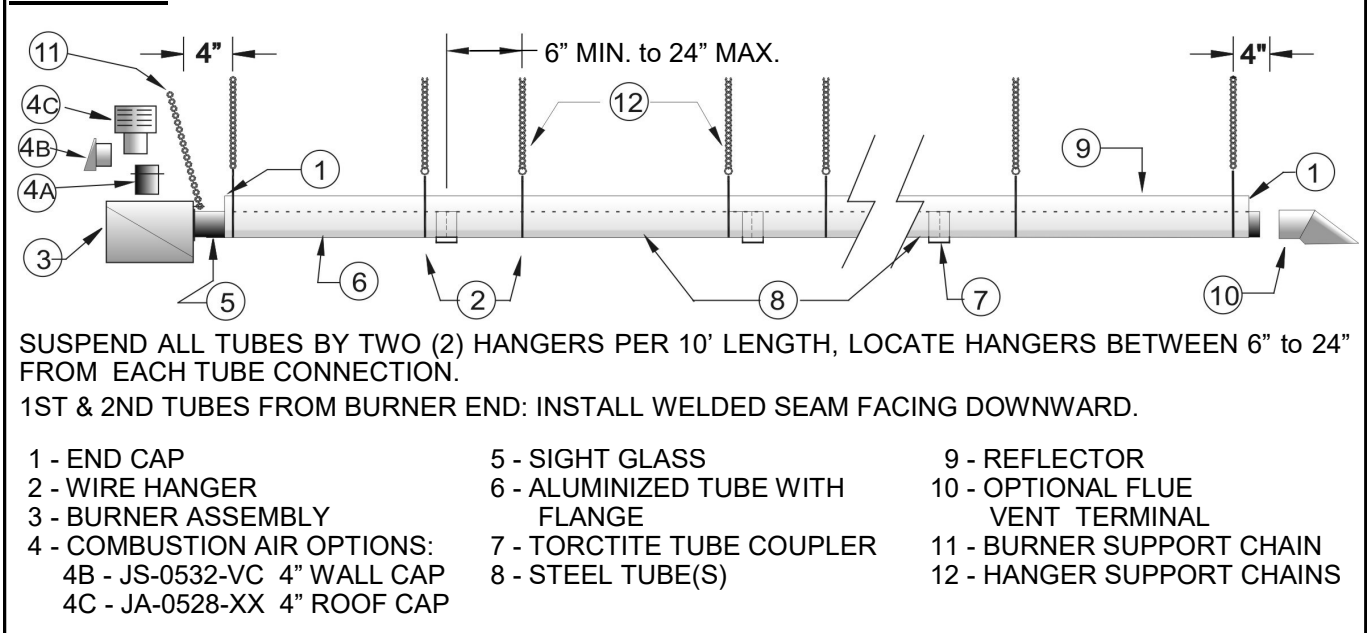
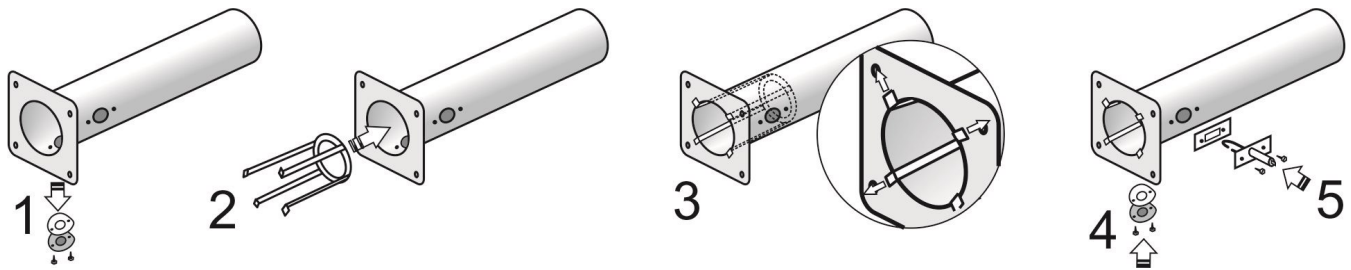

FIGURE 8A: INSTALL FLAME RECTIFIER IN TUBE , THEN INSTALL IGNITER

All input rates: EXCEPT 80/60 does not require a flame rectifier.
 Flame Rectifier is shipped inside the Burner box.
 Igniter is shipped taped inside the Burner box.



- 1 Remove & retain sight glass
- 2 Insert Flame Rectifier into tube

- 3 Feet of the flame rectifier seat against the tube flange and point toward flange corners

- 4 Reinstall sight glass
- 5 Install igniter with gasket into tube port

FIGURE 8B: BOLT BURNER TO TUBE FLANGE

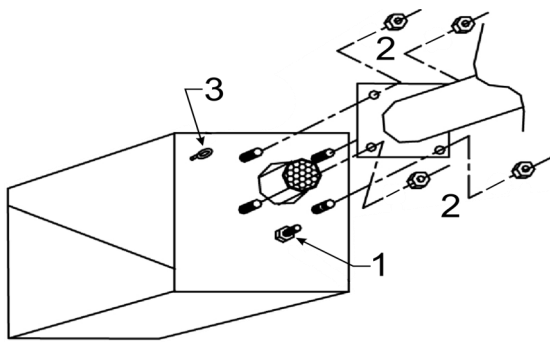

Note: Flange Gasket not required between burner and tube flange

- 1. Fifth Nut (Holds Inner Burner to Housing - Do Not Loosen or Remove)
- 2. Insert four burner bolts through the tube flange, secure tightly with lock nuts.
- 3. Secure suspension chain to eye bolt to stabilize burner

FIGURE 9: COUPLER INSTALLATION (NOTE: See Section 9.3 for 'Special Couplers' at first tube joint: 175,000 & 200,000 models)

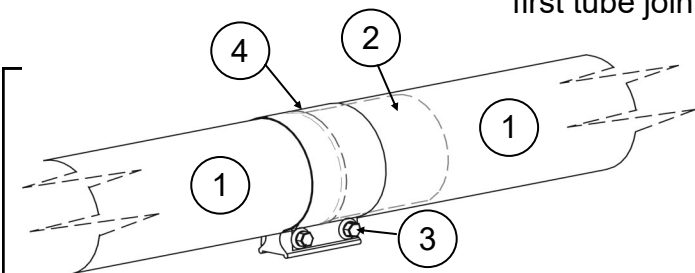

- 1. Tube
 - 2. Swaged end of upstream tube
 - 3. Tube Coupler
 - 4. Centre coupler over tube joint
- Tighten coupler bolts to 40 ft-lbs.**

FIGURE 10: HANGER / REFLECTOR ORIENTATION HORIZONTAL TO 45°

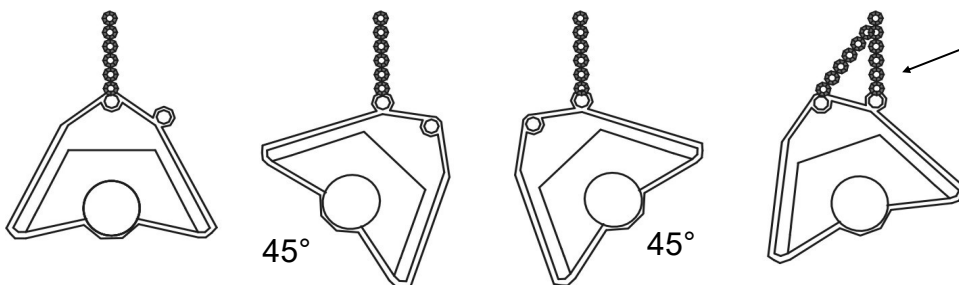

FOR ANGLE LESS THAN 45° USE CHAIN TO BOTH EYES ON HANGER

9.2 SETU / ITTU 'U'-TUBE SYSTEM ~ BURNER AND TUBE INSTALLATION

TURBULATOR NOTES:

- Refer to Section 26, for details on turbulator sizes and location in system

■ Prior to Installation:

- **200 / 140 x 30 ft-U** : Remove and discard 40" turbulator from the upstream end of last tube

1) Install Hangers using chain or other suitable suspension hardware at each side of the hanger: See Figure 11 next page

- i: Two hangers for first section (from burner), and one hanger for each additional section
- ii: No closer than 12" and no further than 14" from the burner/tube flange
- iii: No closer than 6" from a tube connection in the system
- iv: No further than 18" from a tube connection in the system
- v: If angle mounting a 'U' Tube model, the vent side must be in the upper position

2) With all hangers in alignment and suspended at the same height (and angle), insert first aluminumized tube section on to the first two hangers: See Figure 12A next page

- Also lay the vent end tube on to the first two hangers - check tubes for turbulator label to ensure the correct tube is located at the vent end

NOTE: INSTALL THE FIRST AND SECOND TUBES (FROM BURNER) WITH THE WELDED SEAM ALONG THE TUBE LENGTH FACING DOWNWARD

3) Fasten flanged tube to hangers with 'U' bolts:

- All tubes on the burner-side of the heater are bolted to the hangers with 'U' bolts
- Tubes on vent-side simply rest in the hanger notch and do not fasten to the hanger.

4) Install Flame Rectifier (EXCEPT input 80/60); install igniter - See Figure 8A previous page.

5) Bolt burner to flange on first tube section - See Figure 8B previous page.

IMPORTANT NOTE: Models with inputs 175,000 & 200,000 refer to section 9.3

6) Slide a Torctite tube coupler over the swaged end of the first tube, then join the second tube over the swage in the first tube -

7) Slide the Torctite coupler into position across the center of the tube joint - SEE FIGURE 9

IMPORTANT: TOURQUE THE COUPLER BOLTS TO 40 ft-lbs

8) Subsequent lengths of tube can then be installed on both sides of the hangers by joining them together swaged portion inside the next tube and locking the joints using the Torctite coupler. SEE FIGURE 9.

9) Install Turn Box: See Fig 12B

- The Turn Box has "long" and "short" tube legs
- The 'long' leg attaches to the burner-run tubes
- The 'short' leg attaches to the vent-run tube side - tubes end short of burner for connection of vent pipe

FIGURE 11 'U'-TUBE TYPICAL HANGER & SUPPORT SPACING

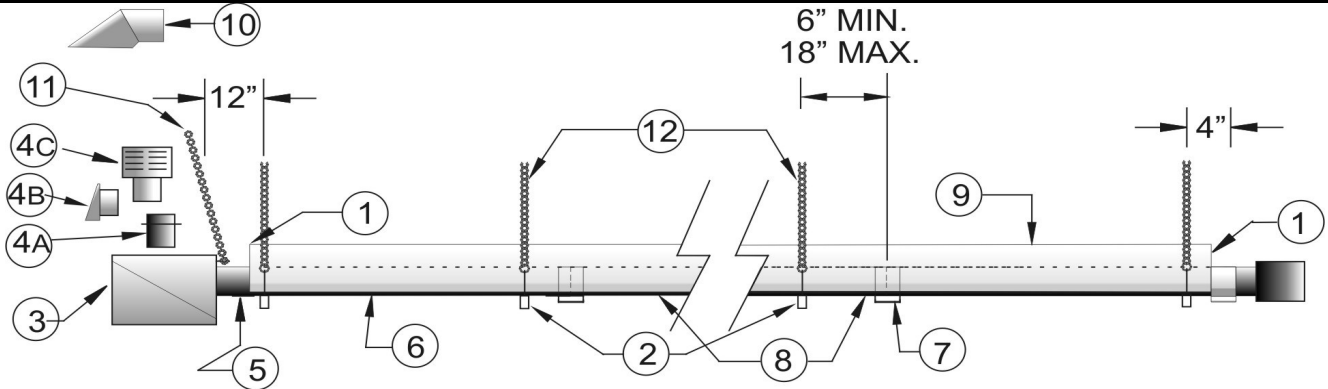

SUSPEND FIRST TUBES BY TWO (2) HANGERS, THEN SUBSEQUENT SECTIONS BY ONE HANGER

- LOCATE HANGERTS BETWEEN 6" to 18" FROM EACH TUBE COUPLER.
- INSTALL FIRST AND SECOND TUBES (FROM BURNER END) WITH WELDED SEAM FACING DOWNWARD.

- | | | |
|-----------------------------------|---------------------------------|----------------------------|
| 1 - END CAP | 4B - JS-0532-VC 4" WALL CAP | 8 - STEEL TUBE(S) |
| 2 - WIRE HANGER | 4C - JA-0528-XX 4" ROOF CAP | 9 - REFLECTOR |
| 3 - BURNER ASSEMBLY | 5 - SIGHT GLASS | 10 - FLUE VENT TERMINAL |
| 4 - COMBUSTION AIR OPTIONS: | 6 - ALUMINIZED TUBE WITH FLANGE | 11 - BURNER SUPPORT CHAIN |
| 4A - JS-0532-SE 4" INTAKE ADAPTER | 7 - TORCTITE TUBE COUPLER | 12 - HANGER SUPPORT CHAINS |

FIGURE 12: 'U' TUBE MODELS

FIGURE 12A: 'U' TUBE HANGER

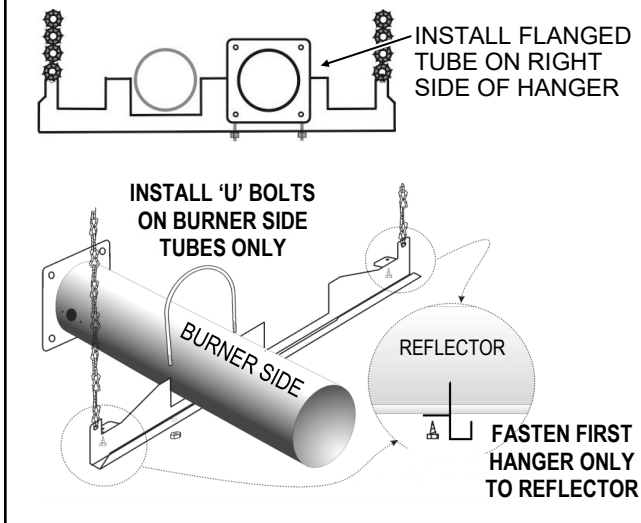

FIGURE 12B: TURN BOX CONNECTION

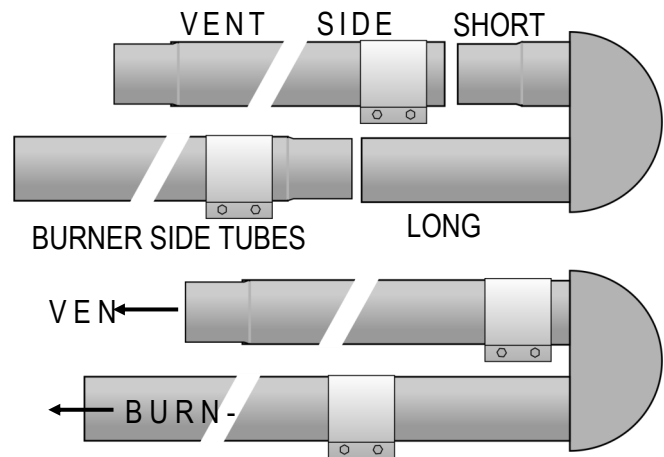
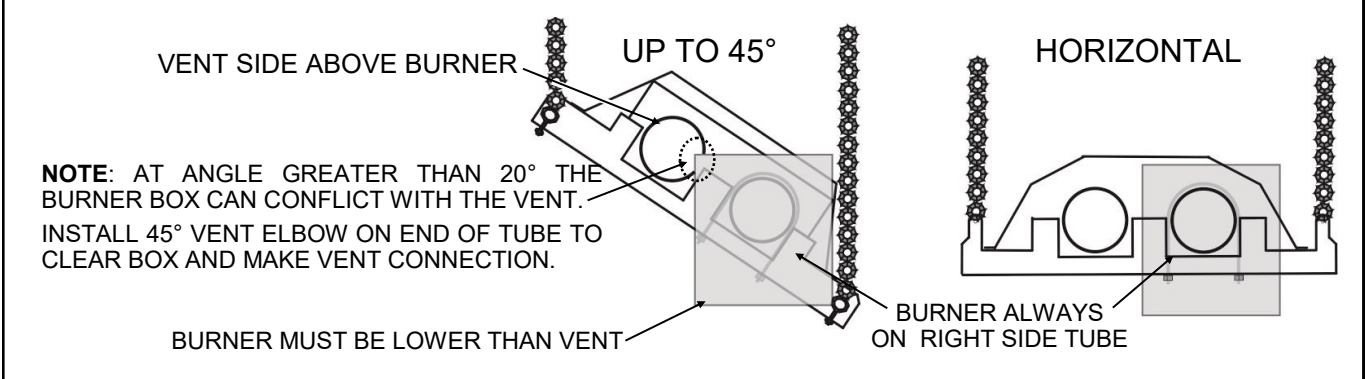

FIGURE 13: 'U' TUBE MODEL ORIENTATION





9.3 SPECIAL COUPLING: 175,000 & 200,000 Btuh

NOTE: The joint of 1ST & 2ND tubes of 175,000 & 200,000 heaters experience strong forces of expansion. Follow instructions below for special coupling of the tubes.

SPECIAL COUPLER INSTALLATION

1. Note the 2 holes opposite each other at the swaged end of the first tube (flanged)
2. Install the **first tube** with 2 holes (swaged end) at the 3 and 9 o'clock position, with the **welded seam located in the lower half of tube, facing downward**
3. Slide the loosened tube coupler on to the first tube, past the swage
4. The second tube has a $\frac{1}{4}$ " hole at the female end.
5. Slide second tube over swaged end of first tube to align the hole in the second tube with one of the holes in the first tube
6. Final alignment of the holes can be accomplished using a screw driver or other tool
7. **IMPORTANT:** Insert $\frac{1}{4}$ " rivet into the hole to secure the tube connection
8. Slide coupler into position – half onto each tube – covering the rivet head
9. Tighten coupler bolts to 40 ft-lb
10. Install reflectors

FIGURE 16 SPECIAL COUPLING:

- **175,000 & 200,000 Btuh - Fasten Second Tube to First Tube -**

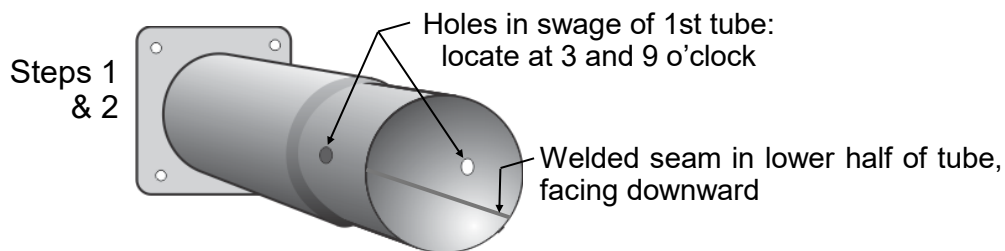

Steps 3 to 6

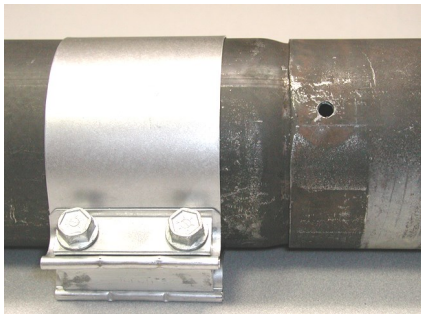

Step 7

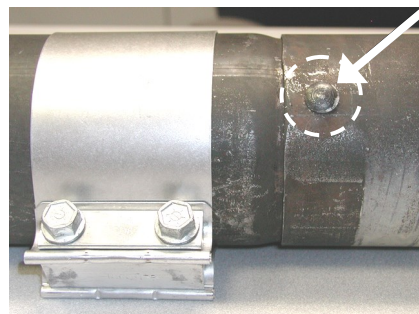

Steps 8 & 9

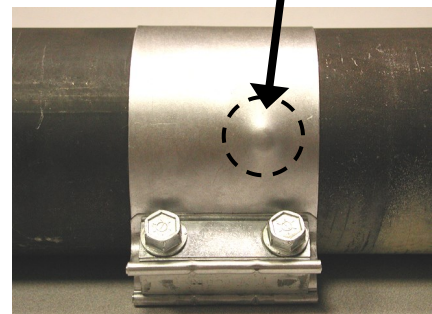

10. REFLECTOR INSTALLATION

NOTE: Ensure that you are installing a single reflector - reflectors can 'stick together' in packaging - take care to separate them.

SET / ITT - STRAIGHT TUBE: After burner and tubes have been installed, slide the reflectors one at a time into the wire hangers. As each successive reflector is installed on an in-line installation, the ends of the reflectors will overlap to provide continuous coverage over the entire tube system. The overlapping joints **MUST BE FASTENED TOGETHER** with a sheet metal screw.

Note that for either horizontal or angle mounting of the reflector, the tube must be level along its length. Improper mounting can result in overheating of controls and combustible materials.

Reflector extensions can be added to the heaters as an option. *See Figure 15 and instructions next page*

SET-U / ITT-U - 'U'-TUBE: After burner and tubes have been installed, slide the double-wide reflectors one at a time onto the hangers. Fasten the FIRST hanger nearest the burner to the reflector with a sheet metal screw up through the hole in the tab at each end of the hanger.

Do not fasten any other hangers in the system to reflectors. SEE FIGURE 12A

As each successive reflector is installed, the ends of the reflectors will overlap to provide continuous coverage over the entire tube system. The overlapping joints **MUST BE FASTENED TOGETHER** with sheet metal screws - Note that for both horizontal and angle mounting, the tube must be level along its length. Improper mounting can result in overheating of controls and combustible materials.

Reflector extensions can be added to the heaters as an option. *See Figure 15 and instructions next page*

FIGURE 15 REFLECTOR EXTENSIONS

(OPTIONAL - IF REQUIRED)

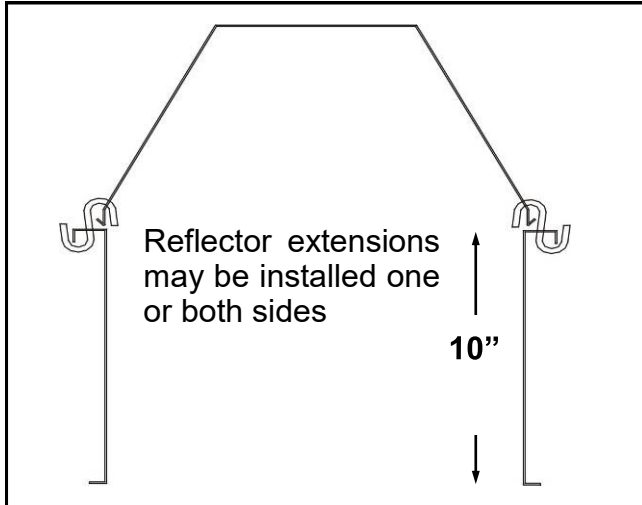

Reflector Extension Kit JS-0509-KT

Includes:

- Qty 1 x 10 ft long x 10 inch deep reflector extension
- Qty 3 x "S" Hooks

1. Reflector extensions may be installed on one side or both sides of the reflector
2. Reflector extensions are 116" long
3. Holes (3) in the reflector extension for "S" hooks are located 2.25" from each end and one at the center
4. Drill 1/4" holes in the reflector 3/4" up from the bottom edge of the reflector to align with the 3 holes in the top of the reflector extension

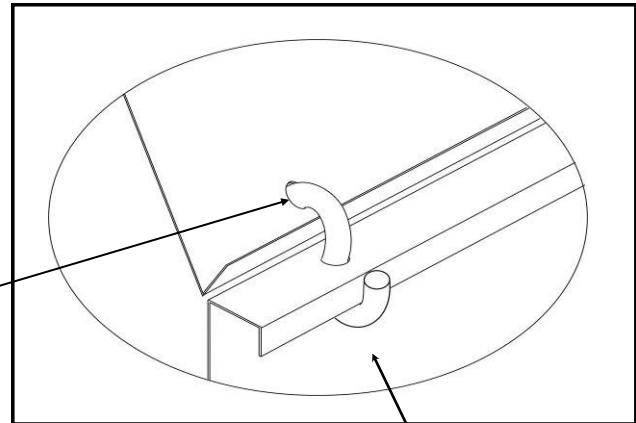

5. Insert "S" hook down through hole in the top of the reflector extension
6. Rotate "S" hook approx. 90°, and insert into hole drilled in reflector
7. Settle reflector extension into place

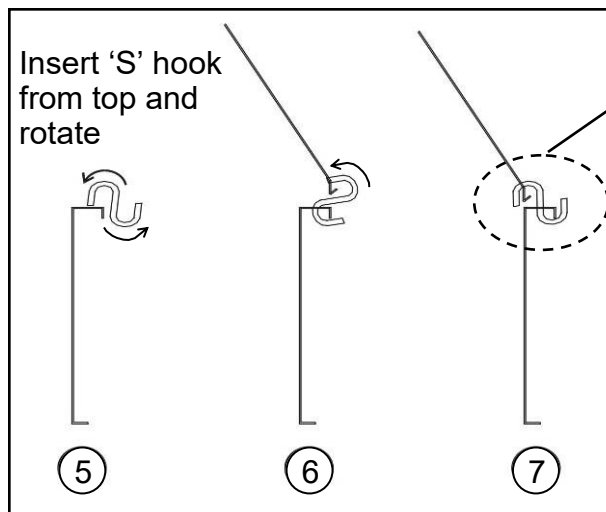

11. FLUE VENTING - RADIANT TUBE HEATER



IMPORTANT

Effective January 1, 2019: Changes to the ANSI/CSA standard that governs Radiant Tube Heaters specify the following appliance CATEGORIES and VENTING:

- **Vertical Vent Through Roof (Category I):** For vertical vent, this tube heater series operates with a negative static vent pressure and a vent temperature that does not result in excessive condensate in the vent and is defined as a Category I appliance. Refer to details below.
- **Horizontal Vent Through Wall (Category III):** For horizontal vent, this tube heater series operates with a positive static vent pressure and a vent temperature that does not result in excessive condensate in the vent and is considered a Category III appliance. Refer to details below.



WARNING

Inadequate venting of a heater may result in asphyxiation, carbon monoxide poisoning, injury or death. This heater may use a vent connection or indirect venting system to remove products of combustion from the space. Seal all vent connections with high temperature sealant. Venting must be in accordance with all local, state, provincial, and national codes (ANSI Z223.1/NFPA 54 in USA; B149.1 in Canada) and as indicated below in this manual.



THIS TUBE HEATER IS CERTIFIED FOR VENTING DIRECTLY TO THE OUTSIDE OR UNVENTED (INDIRECT VENTING) APPLICATIONS.

UNVENTED (INDIRECT MECHANICAL VENTING SYSTEM)

USA: Natural or mechanical means shall be provided to supply and exhaust at least 4ft³/min/1000Btuh (0.38m³/min/kW) input of installed heaters. Some local codes may require an electrical interlock to a dedicated exhaust fan. Exhaust must be located as high as practicable in the structure above the level of the heater(s). Consult your local code and ANSI Z223.1 latest edition for all venting requirements and practices.

Canada: It is required that the heater(s) be electrically interlocked to dedicated exhaust fan(s) by means of an Air Proving Switch. Exhaust fan(s) must be sized to create 300 cfm (8.5 cu m/min) exhaust for every 100,000 Btuh (30 kW) or any fraction thereof of total input of installed equipment. Exhaust must be located as high as practicable in the structure above the level of the heater(s). Sufficient supply air must be provided. Consult the latest edition of CSA.B149.1 Section 8 for venting system and air supply requirements.

VENTED TO THE OUTSIDE - GENERAL REQUIREMENTS

It is the responsibility of the installer to adhere to these instructions and all current local codes and/or ANSI Z223.1 (NFPA 54) or CSA.B149.1 latest editions for all venting requirements, and practices. All vent pipe will be certified to meet Category I (vertical vent) or Category III (horizontal vent) appliance requirements, depending on the vent configuration of a particular installation.

It is a normal condition that during heat-up and cool-down a tube heater will expand and contract. Allowances for heater expansion must be made in the venting and combustion air ducting. Improper installation can result in property damage, injury or death.

- When vented: The system must not be operated in a negative air condition unless combustion air is ducted from outside to the burner. If negative pressure is experienced or anticipated, the open port (barb) on each of the blocked flue and proving air switches must be Tee'd together and connected directly to outside air using a field supplied 1/4" plastic hose from the tee between the switches to outside of building.
- All approved vent pipe, connectors, and adapters are supplied locally by others according to

appliance Category, and specifications below.

- All venting must meet requirements of Local Codes or, in the absence of local codes, with the *National Fuel Gas Code*, ANSI Z223.1/NFPA 54; or the *Natural Gas and Propane Installation Code* CSA B149.1.
- A vent connector shall comply with local codes and be firmly attached to the flue collar by 3 x 1/2" sheet metal screws. Seal penetrations and connections with high temperature RTV silicone sealant.
- Install a minimum 12" straight vent connector before any Tee or 90° Elbow.
- The connection of vent components must be secured as specified in the installation instructions by the vent manufacturer.
- For vertical vent, any horizontal vent section will slope upwards away from the heater not less than 1/4 inch rise per foot of run.
- For horizontal vent, slope downward away from heater a maximum of 1/4 inch down per foot of run.
- When the vent pipe passes through a cold or unheated area where the ambient temperature is likely to produce condensation of the flue gases, the vent pipe will be insulated with a suitable material as certified and specified by the insulation manufacturer to withstand temperature up to 460°F (238°C).
- The vent system must **always** be adequately supported to prevent sagging.
- The vent configuration will allow for expansion and contraction in length of the tube heater.
- As an Option for vertical vent, two heaters may be vented through an approved common 4" x 4" x 6" Vent Tee, supplied by the manufacturer, or by using approved components as indicated in local codes. Vent pipe from each heater is not required to be equidistant to the vent Tee, but must comply with local code requirements. A common thermostat or "ON/OFF" switch must control commonly vented heaters. **Common vent is not allowed for Category III horizontal vent application.**

COMBINED SYSTEM LENGTH: Tube Heater + Vent + Combustion Air Duct:

- **Refer to Table 3 next page, COMBINED SYSTEM LENGTH: TUBE + AIR DUCT + VENT.** Lengths in the table apply to either Vertical or Horizontal vent.
- **COMBINED SYSTEM LENGTH includes:** Tube Heater length + combustion air duct + vent + elbows. Each 90° elbow in the system has an equivalent length of 5 ft.
- A maximum of 2 elbows is allowed in any portion (duct, tube heater, vent) with the exception of up to three 90° elbows in a vertical vent run through the roof, for a total of maximum 6 (vertical vent: 7) 90° elbows in the combined system.
- Combustion air duct is not to exceed lengths in table below and may be 4" or 5" diameter for inputs less than 200,000 Btuh, but must be 5" diameter for inputs 200,000 Btuh and greater.
 - 5" diameter duct requires a reducer to 4" diameter at the connection to blower inlet.
- Exceeding the allowable lengths in the table below can create combustion and/or condensation issues and will void Certification and the heater warranty.
- Do not exceed the **Maximum Combined System Length** regardless of the allowed maximum length of individual vent or combustion air duct.

TABLE 3 COMBINED SYSTEM LENGTH: TUBE + AIR DUCT + VENT

Installations up to 4500 ft - Higher altitudes refer to Section 27

SET / ITT Model	Do Not Exceed Max. Combined System Length*		Max. Vent Length* Individual: 4" Ø Combined: 6" Ø	Max. Air Duct Length* (by Duct Diameter)		Example
	With 4" Ø Air Duct	With 5" Ø Air Duct		4" Ø	5" Ø	
80 / 60	80 ft	100 ft	Up to 20 ft	20 ft	40 ft	155/110 Model: Tube Heater Length 50 ft 1 x 90° elbow (vent) 5 ft Straight vent 20 ft 1 x 90° elbow (duct) 5 ft Air Duct: 4" Ø <u>17 ft</u> Combined Length 97 ft Max. Allowed 100 ft
110 / 75	100 ft	120 ft	Up to 30 ft	20 ft	40 ft	
130 / 90	100 ft	120 ft	Up to 30 ft	20 ft	40 ft	
155 / 110	100 ft	120 ft	Up to 30 ft	30 ft	50 ft	
175 / 125	120 ft	140 ft	Up to 40 ft	30 ft	50 ft	
200 / 140	-	140 ft	Up to 40 ft	Use 5"Ø	50 ft	

HEATER EXPANSION AND VENT CONFIGURATION

A radiant tube heater will expand and contract as it heats and cools. Configuration of the vent must allow for heater expansion.

VERTICAL VENT: Orientation of the vent at 90° to heater will allow for heater expansion and contraction.

HORIZONTAL VENT: (See FIG. 17)

- Wall Thimble or flashing at wall that allows movement of the vent through the opening. Do not seal the vent to the thimble or flashing with caulking.

OR

- Offset vent with two x 90° elbows. Install minimum 12 inch length of straight vent between elbows. Vent can be sealed with caulking at non-combustible wall.
- Other means of slip fit installation of the vent are acceptable providing there is adequate allowance for free expansion and contraction of the system, and free flow of vent gases.

FIGURE 17: ALLOW FOR HEATER EXPANSION - HORIZONTAL VENT - TOP VIEW

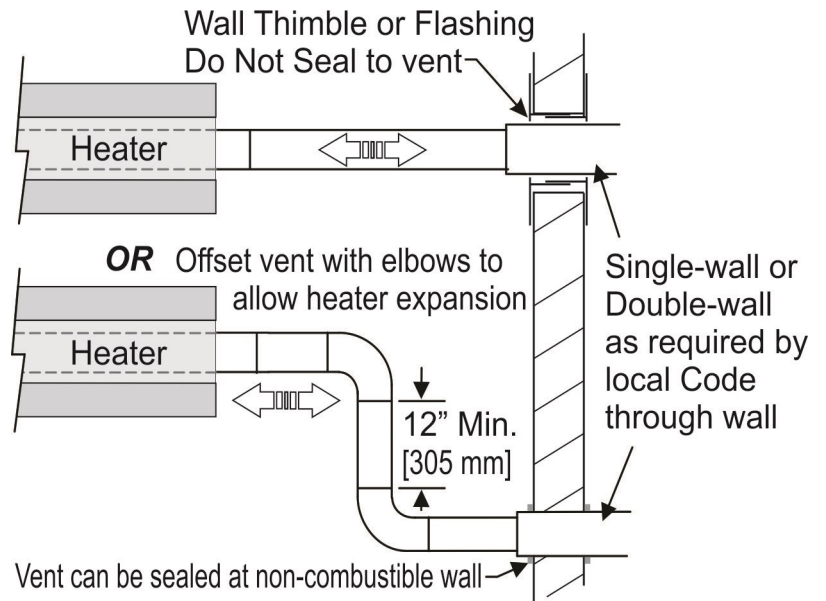

COMMON VENTING

For vertical vent only, two heaters can be commonly vented using 4"x 6"x 4" Vent Tee JA- 0514-XX. Both heaters must be operated using one common thermostat. Common vent is 6 inch diameter. Category III (horizontal vent) heaters cannot be common vented.

VERTICAL VENT THROUGH THE ROOF (CATEGORY I):

It is the sole responsibility of the installer to adhere to all current local codes and/or ANSI Z223.1 / CSA.B149.1 latest editions for all venting requirements, and practices. Also adhere to instructions below, and the instructions of the vent manufacturer. Use vent materials certified for Category I.

All models of this series heater are certified Category I for vertical venting. See FIG. 18.

- The vertical Type B-vent must extend at least 5 feet above the flue collar of the highest connected heater.
- USA: Horizontal run of single wall vent or vent connector ("H" in FIG. 18) must not exceed 75% of the vertical height of the vent. If it does, then the vent system must be for Category III.
- Single wall vent connector material must be corrosion-resistant galvanized steel with a minimum thickness specified in local code.
- A vent connector must be secured to the flue collar using quantity 3 x #8 x 1/2" sheet metal screws. Seal penetrations and connections with high temperature RTV silicone sealant.
- A horizontal vent connector shall be installed and supported without any dips or sags and shall slope upward toward the vent or chimney at least 1/4 in./ft .
- Use a certified termination cap as supplied by the manufacturer of the vent.
- When vent and combustion air are taken through the roof, the exhaust vent should always terminate higher than the combustion air intake, to prevent recycling the products of combustion back into the heater.
- The vent must extend at least 2 feet above the highest point where it passes through a roof. The vent must also extend at least two feet higher than any portion of a building within a horizontal distance of 10 feet.
- Keep vent connector runs as short as possible with a minimum number of elbows. Refer to the current edition of ANSI Z223.1 (NFPA 54) or CSA-B149 installation codes for maximum length of horizontal vent and vent connector.
- Total length of the vent connector and vent pipe cannot exceed the values in Table 3 above.
- A single-wall vent connector shall not be insulated.
- For single-wall vent clearance to combustibles is 6" except where a listed clearance thimble is used. Clearance to combustible material for Type B-Vent or factory-built vent per the vent manufacturer's instructions.
- When an existing Category I heater is removed or replaced, the original venting system may no longer be sized to properly vent the attached appliances. Improperly sized venting systems can result in vent gas leakage or condensation.

FIGURE 18: VERTICAL VENT

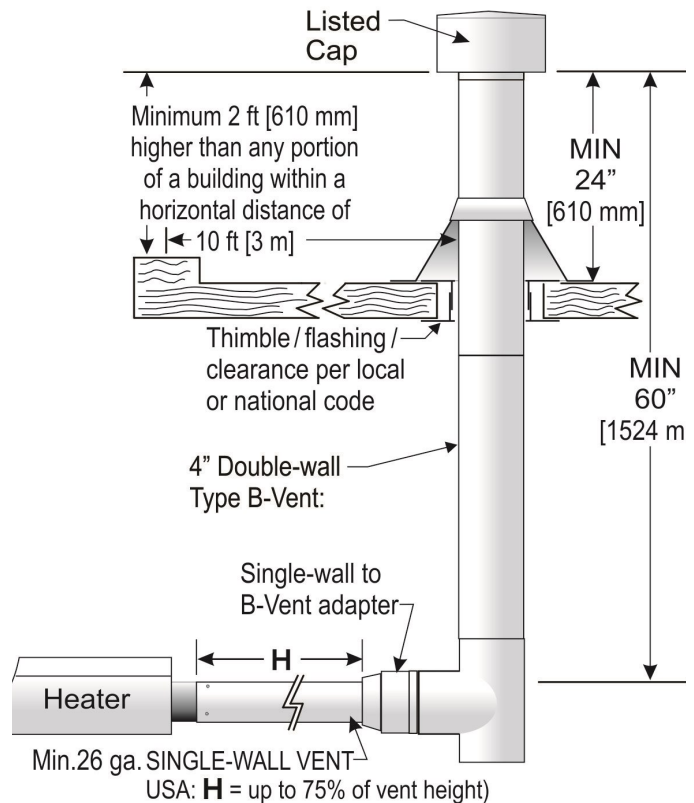

HORIZONTAL VENT THROUGH THE SIDEWALL (CATEGORY III):

All vent must be installed in accordance with local codes or, in the absence of local codes, with the *National Fuel Gas Code* in the USA, ANSI Z223.1/NFPA 54; or the *Natural Gas and Propane Installation Code* CSA B149.1 in Canada.

When installed with a horizontal vent through a sidewall, this heater is a Category III appliance, and the vent system must be approved for Category III application in accordance with UL-1738 or ULC-S636. Do not use PVC or plastic vent pipe.

- Use either a certified Category III venting system, or single wall vent pipe with all of the joints and seams sealed with a heat-resistant pliable sealant.
- The vent system must be installed in accordance with these instructions, and the instructions of the vent manufacturer.
- A single wall vent system may use a single continuous 36 inch section of double wall vent pipe to pass through an exterior wall:
 - Single wall galvanized vent pipe (C-Vent): Minimum 26 ga.
 - Single Wall to Double Wall Adapter: Duravent 4PVP-AD Adapter or equivalent.
 - 36 Inch Double wall vent through outside wall: Duravent PelletVent Pro (PVP) or equivalent:
- Single-wall vent: Seal all joints and seams in the pipe, and the adapter with high temperature Red RTV sealant for temperatures up to 600°F (315°C). The sealant must remain pliable when in use. Follow the instructions of the vent manufacturer for sealing vent pipe connections.
- All vent sections and vent connector must be secured using quantity 3 x #8 x 1/2" sheet metal screws. Seal penetrations and connections with high temperature RTV silicone sealant.
- Any horizontal portion of the flue vent system must slope downwards away from the heater a minimum of 1/4" per foot run toward the vent terminal.
- Horizontally vented Category III heaters must be individually vented and cannot use a common vent.
- Use approved 4" (JA-0528-XX) horizontal wall vent terminal or an approved high-wind termination cap.
- Installation of the vent must prevent blockage by snow and protect building materials from degradation by flue gases.
- Install termination cap a minimum of 18 inches from the outside wall to the inside edge of terminal opening to alleviate back pressure caused by turbulent wind conditions (See Fig. 8). This also ensures flue gases are directed away from the structure to protect building materials from degradation by the exhausted flue gases.
- At most two 90° elbows can be installed in a horizontal vent.
- All seams and joints must be checked for gas tightness after installation. With the heater in operation, conduct a leak test on all vent connections, joints, and seams using a soap solution.
- A horizontal flue vent will not terminate less than 1 ft above grade level, unless its location is adjacent to a public walkway, then it must not terminate less than 7 ft above the walkway.
- Clearance above vent terminal under a combustible overhang or soffit:
 - As indicated in FIG. 19 for approved terminations: 4" JA-0528-XX.
 - For other approved terminations: Will terminate 3 ft or more below a combustible soffit or overhang.
- A horizontal vent termination must be a minimum of 6 feet from an inside corner formed by two exterior walls.
- All vent pipe, adapters, thimbles, supplied locally by others.

Specific requirements for horizontal vent in the USA and Canada are on the next page.

USA specific horizontal vent requirements:

- The vent terminal of an appliance with an input up to 50,000 Btu/hr (14.7kW) shall be installed with a 9 inch vent termination clearance from any air opening into a building, and an appliance with an input over 50,000 Btu/hr (14.7kW) shall have at least a 12 inch vent termination clearance. The bottom of the vent terminal and the air intake shall be located at least 12 inches above grade.
- A horizontal vent will not terminate:
 - Less than 3 ft above a mechanical air inlet located within 10 ft.
 - Less than 4 ft below, 4 ft horizontally from, and 1 ft above any window or door that opens, or gravity air inlet to a building.
 - Less than 4 ft horizontal clearance from gas and electric meters, regulators and relief equipment.

CANADA specific horizontal vent requirements:

- A horizontal vent will not terminate:
 - Within 6 ft of a mechanical air supply inlet to any building.
 - Above a gas utility meter and regulator assembly within 3 ft horizontally of the vertical centerline of the regulator vent outlet to a maximum vertical distance of 15 ft.
 - Within 3 ft of any gas pressure regulator vent outlet.
 - Within the following distances of a window or door that can be opened in any building, of any non-mechanical air-supply inlet to any building, or of the combustion air inlet of any other appliance:
 - 12 inches for inputs up to and including 100,000 Btuh (30 kW).
 - 3 ft for inputs exceeding 100,000 Btuh (30 kW).

FIGURE 19: HORIZONTAL VENT THROUGH WALL

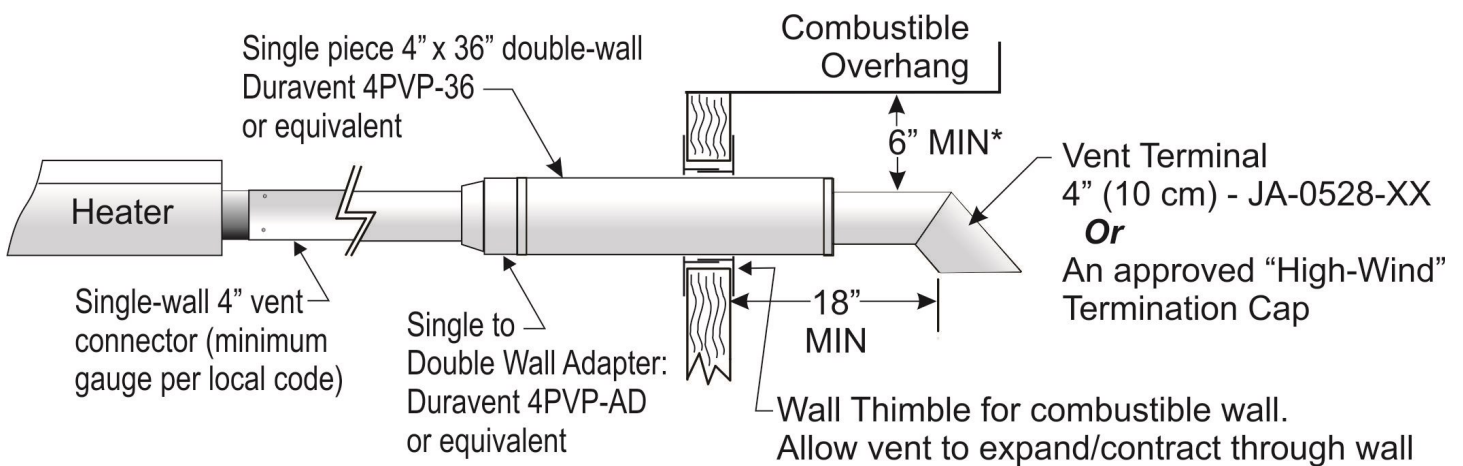

* 6" Clearance above optional Vent Terminal JA-0528-XX - 4" (10 cm). Use of alternate High-Wind terminal may require higher clearance. Refer to Vent Cap manufacturer's instructions.

12. COMBUSTION AIR DUCTING

Do not install filters on the combustion air intake. Ensure adequate clearance around the air intake to allow sufficient combustion air supply to the heater.

An opening is located on the top surface of the burner housing for combustion air. Ensure adequate clearance around this opening to allow sufficient combustion air supply to the heater. Combustion air duct must be constructed of noncombustible material.

When a tube heater is operated in a negative air condition or air-borne dust or contaminants are present as in woodworking and welding shops, air for combustion must be ducted from outside the negative or contaminated area to the 4 inch diameter intake flange supplied on the blower. Maximum system, vent and duct length is listed above.

- The total system length and individual flue vent or the combustion air duct is not to exceed the lengths listed above
- Total combined system length is reduced by five feet for every 90° elbow installed in the vent or duct *and* in the tube system (see above for allowable total lengths)
- Exceeding the allowable lengths may create condensation or soot conditions and will void CSA Design Certification and product warranty

The air intake will not be located less than:

- Three feet above grade
- Twelve inches from flue vent terminal of any heater with input up to 100,000 Btu/hr
- Three feet from flue vent terminal of any heater over 100,000 Btu/hr

This heater has an optional fresh air intake duct hood for wall (JS-0532-VC) or roof cap (JS-0530-XX) to bring combustion air to the heater from outside. Ensure adequate clearance around the air intake to allow sufficient combustion air supply to the heater. If drawing fresh air from outside, it is recommended that any single wall pipe containing cold air be insulated to prevent or reduce condensation on the pipe.

Do not use flexible dryer hose or any 'soft wall' tubing for air inlet duct, the corrugated sides of this tubing restrict air flow. A good quality industry approved insulated flex is allowed.

CAUTION:



In locations where chlorinated Hydrocarbons are in use, such as Trichloroethylene or Chloroethylene Nu it is essential that combustion air be brought in from a non-contaminated area. Burning the fumes from these gases will create Hydrochloric acid fumes, which are detrimental to humans, equipment and buildings. Typical sources of other contaminants are paint removers, paints, refrigerants, solvents, adhesives, degreasers, lubricants, pesticides, etc.



The heater manufacturer cannot anticipate all types and chemical composition of possible contaminants at project sites. Confer with project site safety, health and engineering staff and/or local authorities having jurisdiction such as the Fire Marshall and Department of Labor for possible contaminants and any conflict with the installation of hot surface heating equipment.

13. GAS SUPPLY - HEATER EXPANSION - FLEXIBLE GAS CONNECTION

The gas supply must be installed to the heater using:

- **USA:** an approved Stainless Steel Flexible Gas Connector certified for use on an infrared radiant tube heater (ANSI Z21.24 CSA 6.10);
- **CANADA:** an approved Type 1 Hose Gas Connector (CAN/CGA 8.1).
- The heater must be isolated from the gas supply piping system by closing its individual manual shut off valve (field supplied) during any pressure testing of the gas supply piping system.

CAUTION: Compensation for normal gas supply pipe expansion, and radiant tube heater expansion must be provided. All piping must conform to local codes— Refer to Heater Expansion & Flexible Gas Connection—Sections 14 next two pages



Provide a 1/8 in NPT plugged tapping, accessible for test gauge connection, immediately upstream of the gas supply connection to the heater.

DO NOT use pressure greater than 1/2 psig to pressure check the heater.



TEST FOR LEAKS: All gas piping and connections must be tested for leaks after the installation is completed.

DO NOT USE A MATCH OR OPEN FLAME OF ANY KIND TO TEST FOR LEAKS. Apply soap suds solution to all connections and joints and if bubbles appear, leaks have been detected and must be corrected. **NEVER OPERATE THE HEATER WITH LEAKING CONNECTIONS.**



The supply system should be checked first with heater turned “OFF” followed by another check with heater turned “ON”.

IMPORTANT: Minimum supply line pressure at the inlet to the heater regulator must not be lower than 5.0 inches of water column pressure for natural gas. The supply gas pressure must be checked with all heaters in operation.



Installation of a gas line (trap) “drip leg” is required at the inlet connection tee following the pipe drop to the heater. Failure to provide a “drip leg” could result in condensation and foreign matter passing into the gas valve. Failure to install a “drip leg” in the gas line can cause property damage, injury or death and will void the heater warranty.



TABLE 4

GAS TYPE	<u>INLET SUPPLY PRESSURE</u> INCHES WATER COLUMN		<u>MANIFOLD PRESSURE</u> (tap at gas valve outlet) INCHES WATER COLUMN
	MINIMUM	MAXIMUM	
Natural Gas	5.0	14.0	HI: 3.5
			LO: 2.2
Propane	11.0	14.0	HI: 10.0
			LO: 5.0

NOTE: Access to the manifold pressure test port is on the top of the valve. A 3/16" Allen Wrench is necessary to check this. When checking or setting the manifold pressure, a **water manometer** should be used. Gauges which measure in ounces per square inch or pounds per square inch are not accurate enough to properly measure or set the pressure.

 **WARNING**



THIS HEATER WILL EXPAND IN LENGTH AS IT HEATS UP. It is a normal condition that during heat-up and cool-down a tube heater will expand and contract. Allowances for heater expansion must be made in the gas connection, venting and combustion air ducting. Improper installation, alteration, or adjustment can result in property damage, injury or death. **See also Section 13**



The Btuh input and the tube length determine the overall expansion that occurs. A typical infrared tube installation will expand toward both the Burner and the vent end.



To allow heater expansion the gas supply must be installed using the flexible gas connector supplied in the burner kit:

In the USA: a stainless steel Flexible Gas Connector certified for use on an infrared radiant tube heater (ANSI Z21.24 CSA 6.10);

in CANADA: a Type 1 Hose Connector (CAN/CGA 8.1). Also the flue vent, and combustion air intake (if used) must be installed in such a manner that the normal expansion of the heater will be accommodated.

 **IMPORTANT:** See next page: orientation of flexible gas connector between heater and gas supply.

TABLE 5

SET / ITT Model	Tube Length Feet	Approx. Expansion in Length	USA: Mandatory Flexible Gas Connector ID x Length - Part #	CANADA: Mandatory Type '1' Gas Hose Size - Part #
80 / 60,000	20 / 30	1 3/4"	1/2" x 24" - JL-0771-XX	1/2" x 36" - JL-0771-RC
110 / 75,000	30 / 40	2"	1/2" x 24" - JL-0771-XX	1/2" x 36" - JL-0771-RC
130 / 90,000 NG	30 / 40	2"	1/2" x 24" - JL-0771-XX	1/2" x 36" - JL-0771-RC
130 / 90,000 Propane	40 ONLY	2"	1/2" x 24" - JL-0771-XX	1/2" x 36" - JL-0771-RC
155 / 110,000	40 / 50	2 1/2"	3/4" x 36" - JL-0771-YY	3/4" x 36" - JL-0771-RB
175 / 125,000	50 / 60	2 3/4"	3/4" x 36" - JL-0771-YY	3/4" x 36" - JL-0771-RB
200 / 140,000	50	2 3/4"	3/4" x 36" - JL-0771-YY	3/4" x 36" - JL-0771-RB
200 / 140,000	60	3 1/4"	3/4" x 36" - JL-0771-YY	3/4" x 36" - JL-0771-RB

FIGURE 20 ORIENTATION OF FLEXIBLE GAS CONNECTOR



The flexible gas connector **MUST** be installed in the orientation shown below as required by national installation codes and by the certification standard of this heater. This orientation protects the flexible gas connector from damage due to movement during heater expansion.

It is the responsibility of the installer to ensure correct installation of the flexible gas supply.

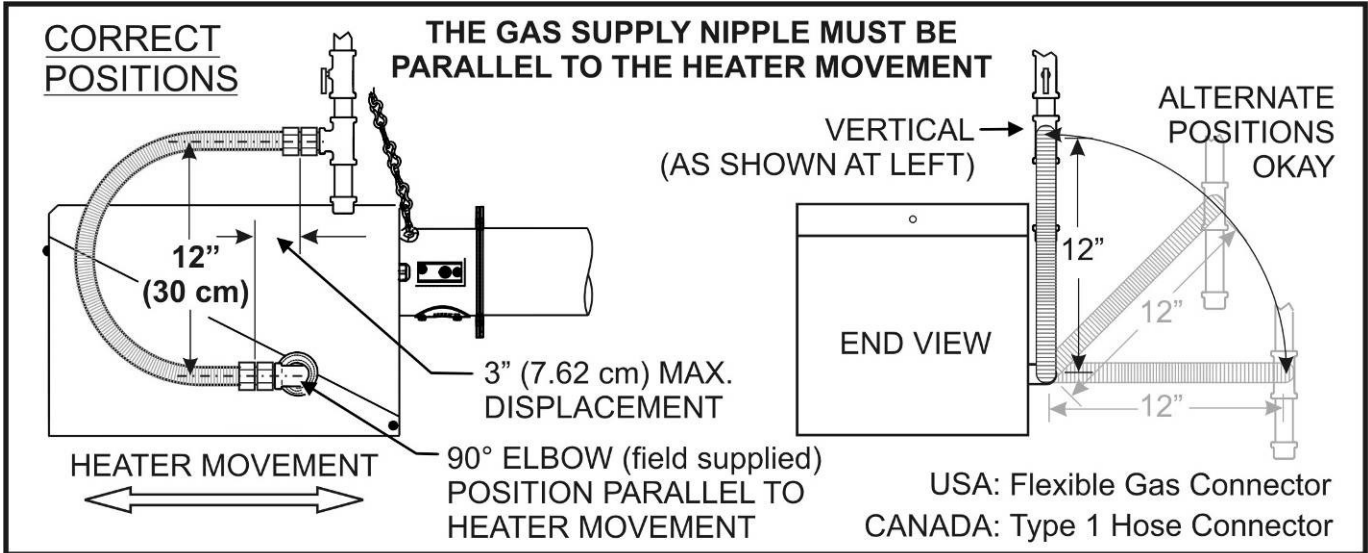

WARNING: CONNECTOR MUST BE INSTALLED IN "C" CONFIGURATION. USE ONLY THE CONNECTOR OF PROPER LENGTH AND NOMINAL ID THAT IS FURNISHED WITH THIS HEATER - SEE TABLE PREVIOUS PAGE.

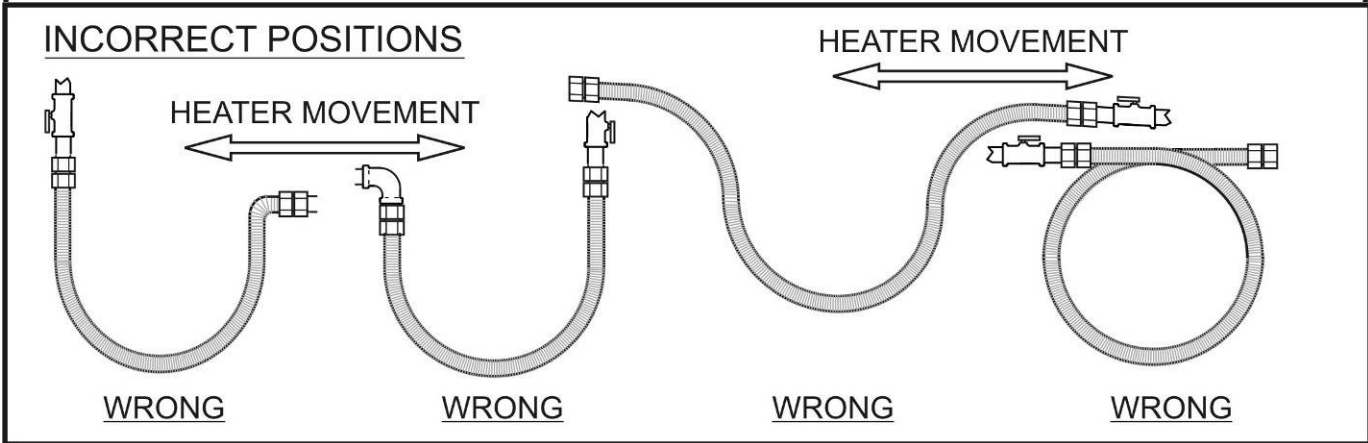

The flue vent, and combustion air duct (if installed) must also be configured in such a manner that the normal expansion of the heater will be accommodated. **See Section 11.**

14. ELECTRICAL AND THERMOSTAT WIRING (WIRING DIAGRAMS PAGE 31 & 32)



NOTICE

The heater must be electrically grounded in accordance with the National Electrical Code. ANSI / NFPA 70 or current Canadian Electrical code CSA C22.1.

Appliance and control wiring must be in accordance with all applicable local codes. The total load of all heaters must be considered in determining the required contact rating of the controlling thermostat or switch. Each tube heater requires 120V, 60 HZ electrical power sized for 145VA. The heater includes a 24V/120V relay switch and is to be controlled by a Honeywell FocusPRO 5000 Series TH5220D1037 (or equivalent) 24V Digital Thermostat - Schwank/InfraSave P/N JS-0569-DT. Maximum power flow for internal 24V burner components is 21VA.

A maximum night set-back of 9°F (5°C) is recommended for optimum economy and comfort. To maintain satisfactory comfort levels do not turn off the heating system over night/weekends.

15. HIGH ALTITUDE INSTALLATIONS - *also refer to chart in Section 27*

When this appliance is installed above the altitude stipulated below for the USA or Canada, the input must be de-rated by 4% for each 1000 ft above the altitude listed . **If your local utility supplies gas with a de-rated heat content, no orifice change is required in the heater** . If the gas supply is not de-rated, the orifice must be changed according to the chart in Section 28. Check with your local utility regarding the gas supply and the de-rating of this appliance.

USA: The factory installed orifice for this appliance is approved for altitudes zero to 2000 feet above sea level. When installed above 2000 feet, **refer to Section 28**.

Canada: The factory installed orifice for this appliance is approved for altitudes zero to 4500 feet above sea level. When installed above 4500 feet, **refer to Section 28**.

16. LIGHTING INSTRUCTIONS

Refer to the lighting instructions label on the outside of the burner housing. If the unit locks out on safety, main power to the unit must be manually interrupted for a 30 second reset period before the heater can be restarted.

NOTE: *On initial installation, the unit may lock out on safety owing to the length of time required to bleed air from the gas piping system.*

17. RECOMMENDED MAINTENANCE



Improper adjustment, alteration, service or maintenance can cause property damage, injury or death. This heater must be installed and serviced only by a trained gas service technician.

1. Inspect the entire heater system, venting, and gas supply connections at least annually prior to the heating season. Replace worn parts and repair deficiencies.
2. Check the inlet air opening and the blower periodically, cleaning off any lint or foreign matter. It is important that the flow of combustion and ventilation air must not be obstructed.
3. Lubricate Blower motor, by adding several drops of oil to oil ports located on the left hand side of the motor.

THE TUBE HEATER BURNER IS COMPLETELY FACTORY ASSEMBLED AND TESTED. ANY ALTERATION VOIDS THE CSA CERTIFICATION AND MANUFACTURER'S WARRANTY. FOR ADDITIONAL INFORMATION, CONTACT YOUR LOCAL DISTRIBUTOR OR MANUFACTURER.

18. WIRING DIAGRAM FENWAL DSI

24 VOLT TWO STAGE GAS VALVE – USING 24V TWO STAGE THERMOSTAT

(FOR MULTIPLE HEATERS PER THERMOSTAT SEE NEXT PAGE)

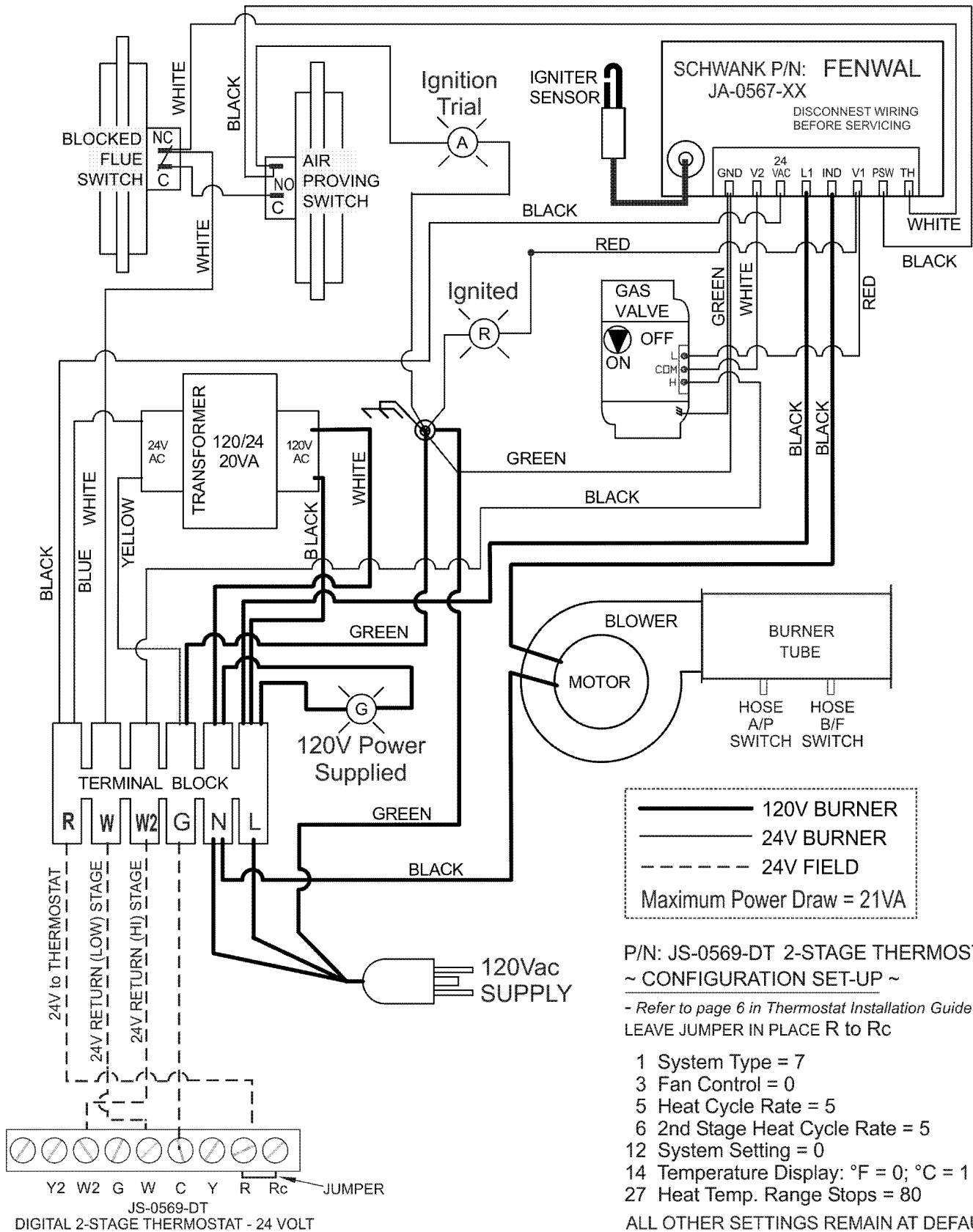

P/N: JS-0569-DT 2-STAGE THERMOSTAT
 ~ CONFIGURATION SET-UP ~
 - Refer to page 6 in Thermostat Installation Guide
 LEAVE JUMPER IN PLACE R to Rc

1 System Type = 7
 3 Fan Control = 0
 5 Heat Cycle Rate = 5
 6 2nd Stage Heat Cycle Rate = 5
 12 System Setting = 0
 14 Temperature Display: °F = 0; °C = 1
 27 Heat Temp. Range Stops = 80
 ALL OTHER SETTINGS REMAIN AT DEFAULT

19. WIRING DIAGRAM - MULTIPLE 2-STAGE HEATERS PER 2-STAGE THERMOSTAT

(FOR SINGLE HEATER PER THERMOSTAT SEE PREVIOUS PAGE)

Centrally locate thermostat between heaters or in heater zone

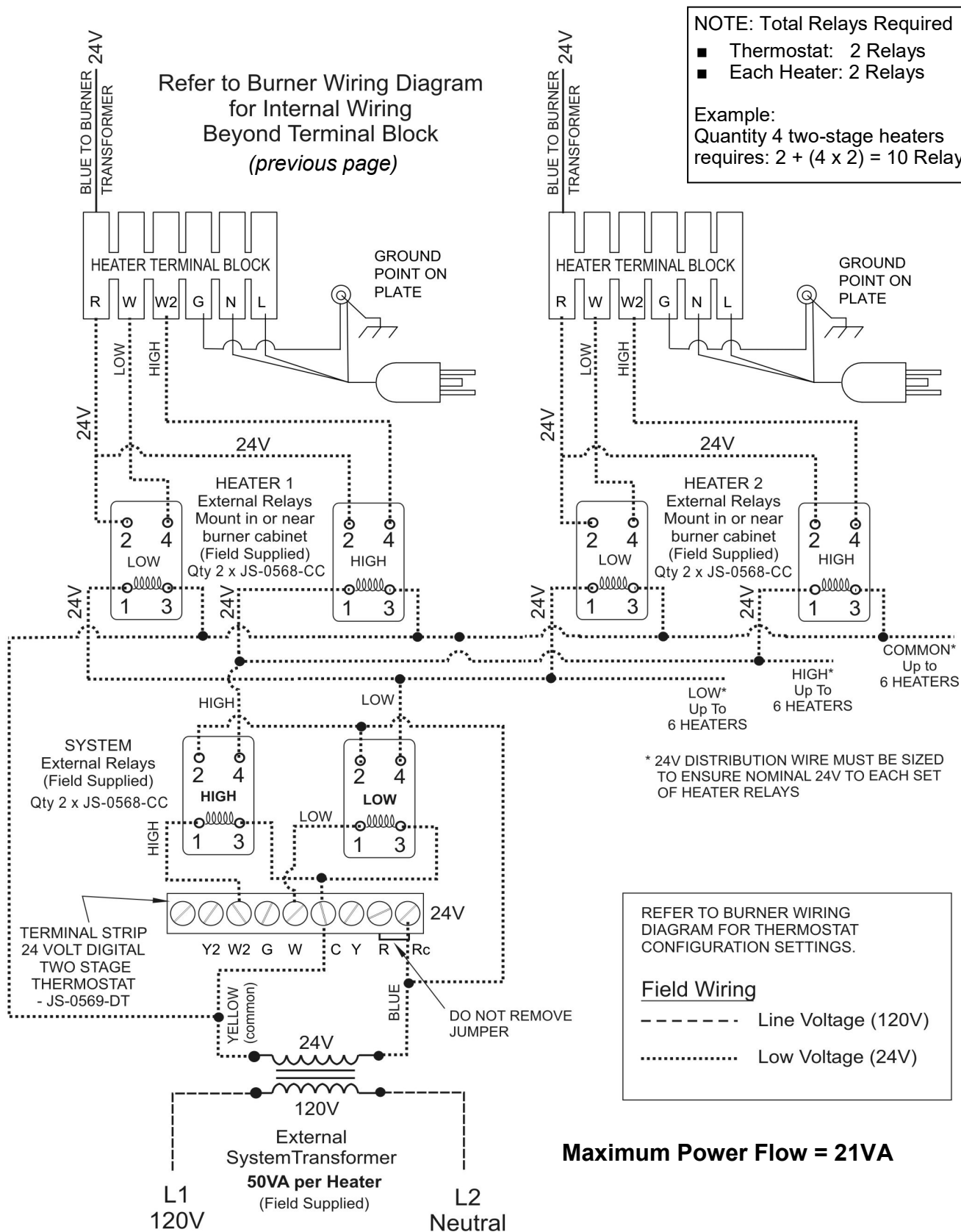

20. FENWAL DSI: SEQUENCE OF OPERATION / FLAME RECOVERY / SAFETY LOCKOUT

Power Up / Stand By

Upon applying 24 volts power to 24VAC, the control will reset, perform a self check routine, initiate full time flame sensing, flash the diagnostic LED for up to four seconds, and enter the thermostat scan state.

Heat Mode

When a call for heat is received from the thermostat supplying 24 volts to TH, the control checks the pressure switch for normally open contacts. The combustion blower is then energized and once the pressure switch contacts close, a 30 second purge delay begins. Following the purge period the gas valve is energized and spark commences for the 15 second trial for ignition.

When flame is detected during the trial for ignition, spark is shutoff immediately and the gas valve combustion blower remains energized. The thermostat, pressure switch, and main burner flame are constantly monitored to assure the system continues to operate properly. When the thermostat is satisfied and the demand for heat ends, the main valve is de-energized immediately, the control senses the loss of flame signal and initiates a 30 second post-purge period before de-energizing the combustion blower.

Failure to Light - Lockout (THREE TRIAL MODEL)

This three-try control will attempt two additional ignition trials with a 30 second inter-purge between trials, before going into 'soft' lockout. The valve relay will be de-energized immediately, and the combustion blower will be turned off following the 30 second post purge period.

If the thermostat continues to call for heat after one hour the control will automatically reset and attempt to ignite the burner again (three trials).

At any time less than the 1 hour auto-reset, recovery from lockout requires a manual reset by either resetting the thermostat or removing 24 volts for a period of 5 seconds.

Flame Failure - Re-Ignition

If the established flame signal is lost while the burner is operating, the control will respond within 0.8 seconds. The HV spark will be energized for a trial ignition period in an attempt to relight the burner. If the burner does not light the control will de-energize the gas valve. Two more attempts will be made to relight the burner. If the burner does not relight the control will go into 'soft' lockout as noted above in "Failure to Light". If flame is re-established, normal operation resumes.

Combustion Airflow Problems -Lockout

Combustion air flow is continually monitored during an ignition sequence by the air flow switch (PSW). If during the initial call for heat the pressure contacts are in the closed position for 30 seconds without an output to the Combustion Blower, an air flow fault will be declared and the control will remain in this mode with the combustion blower off.

If the air flow switch remains open for more than 30 seconds after the combustion blower output (L1 & IND) is energized, an air flow fault will be declared and the control will stay in this mode with the combustion blower on, waiting for the air flow switch to close.

When proper air flow is detected from the air flow switch input (PSW) the control begins the pre-purge period followed with a 15 second ignition sequence.

If the air flow signal is lost while the burner is firing, the control will immediately de-energize the gas valve and the combustion blower will remain on. If the call for heat remains, the control will wait for proper air flow to return. If proper air flow is not detected after 30 seconds an air flow fault signal will be declared. If proper air flow is detected at any time, a normal sequence will begin with the pre-purge period.

Flame Fault

If at any time the main valve fails to close completely and maintains a flame, the full time flame sense circuit will detect it and energize the combustion blower. Should the main valve later close completely removing the flame signal, the combustion blower will power off following the optional post purge period.

Fault Conditions

The LED will flash on for 1/4 second, then off for 1/4 second during a fault condition. The pause between fault codes is 3 seconds.

Error Mode	LED Indication
Internal Control Failure	Steady on
Air Flow Fault	1 flash
Flame with No Call for heat	2 flashes
Ignition Lockout	3 flashes

MOUNTING AND WIRING

The Series 35-61 is not position sensitive and can be mounted vertically or horizontally. The case may be mounted on any surface with #6 sheet metal screws. All wiring must be done in accordance with local and national electrical code. Refer to wire diagram in this manual when connecting the Series 35-61 to other components in the burner.



WARNING

The Series 35-61 DSI Control uses voltages of shock hazard potential. Wiring and initial operation must be done by a qualified service technician. The control must be secured in an area that will experience a minimum of vibration and remain below the operating temperature of 160°F. All connections should be made with UL approved 105°C rated 18 gauge, stranded, .054 thick insulated wire. Refer to wire diagram page 35 when connecting the Series 35-61 to other components in the burner.

TERMINAL	SPADE	DESIGNATION
TH	1/4"	Thermostat Input
PSW	1/4"	Pressure Switch Input
V1	1/8"	Valve Power (MV)
IND	1/4"	Inducer Blower Output
NC	-	Alarm (Not used)
L1	1/4"	120/240 VAC Input (Hot)
24 VAC	1/4"	24 VAC Supply to Processor
V2	1/8"	Valve (MV)
GND	1/8"	Valve & System Ground
Spark	1/4"	Spark & Local Flame Sense

CAUTION:

Label all wires prior to disconnection when servicing controls. Wiring errors can cause improper and dangerous operation. A functional checkout of a replacement control is recommended.

PROPER ELECTRODE LOCATION

Proper location of the electrode assembly is important for optimum system performance. The electrode assembly should be located so that the spark gap is inside the flame envelope about 1 inch (2.5 cm) from the base of the flame at the burner cup.

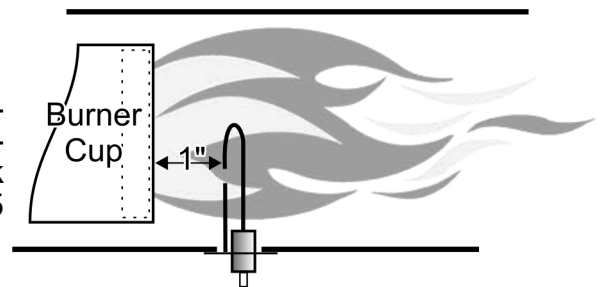

Electrodes should have a gap spacing of 3/16" (0.188" ± 0.031" or 4.76 mm ± 0.81 mm). If this spacing is not correct, the assembly must be adjusted or replaced. DO NOT adjust the curved igniter/sensor prong. Adjust/bend only the ground prong (also see next page).

SPARK IGNITER ADJUSTMENT

Use the following diagram to check the Igniter gap. If the gap is incorrect all adjustments should be made to the **GROUND PRONG/PIN ONLY!** **DO NOT BEND THE IGNITER PRONG!!!!**

USE THE BLACK BARS BELOW AS A GUIDE FOR ADJUSTMENT. USE THE BARS THAT COINCIDE WITH THE FORMAT & SIZE OF THIS PUBLICATION .

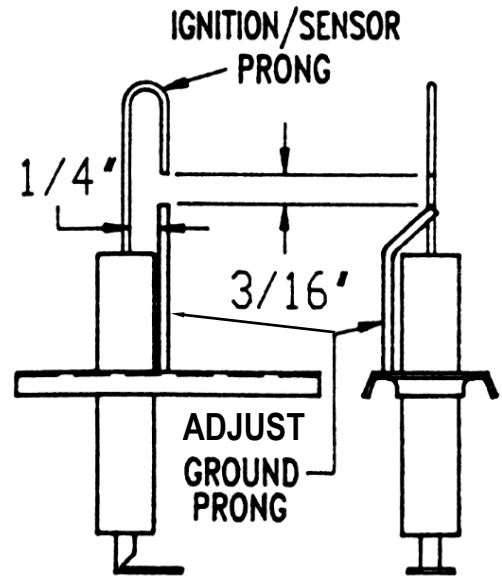
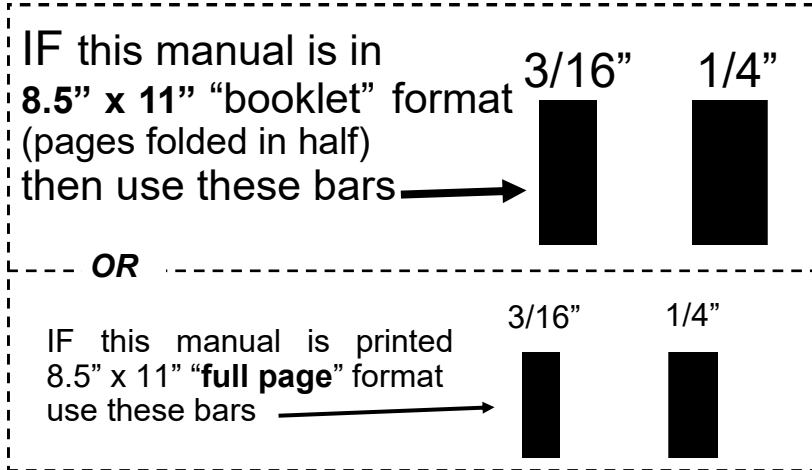

SERVICE CHECKS

Flame current passes through the flame from the sensor to ground. The minimum flame current necessary to keep the system from lock-out is 0.7 microamps. To measure flame current, connect an analog DC microammeter to the FC- FC+ terminals per figure at right.

Meter should read 0.7 μ A or higher. If the meter reads below "0" on scale, meter leads are reversed. Disconnect power and reconnect meter leads for proper polarity.

Multipurpose Meter

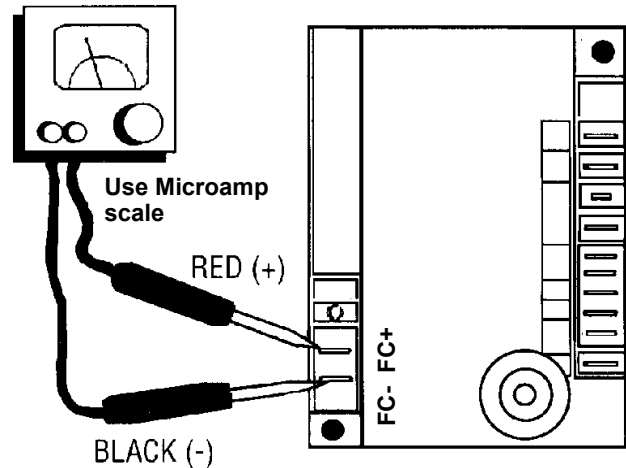

21. TROUBLESHOOTING GUIDE - FENWAL DSI
(also see Heater Troubleshooting next page)

SYMPTOM	RECOMMENDED ACTION(S)
1. Dead	<ul style="list-style-type: none"> A. Miswired - check electrical supply (120Vac ± 5%) B. Transformer bad (24Vac ± 10%) C. Fuse/Circuit breaker bad D. Bad control (check LED for steady on)
2. Thermostat on - no blower output	<ul style="list-style-type: none"> A. Miswired B. Bad thermostat no voltage @ terminal W C. Bad control (check LED for steady on)
3. Pressure switch input okay, but no Trial-for-Ignition after purge delay	<ul style="list-style-type: none"> A. Miswired (check PSW terminal voltage: 24Vac ± 10%) B. Flame sense problem (existing flame: check LED - 2 flashes) C. Bad control (check line voltage between L1 & IND)
4. Valve on, no spark	<ul style="list-style-type: none"> A. Shorted electrode B. Open HV cable C. Bad control
5. Spark on, no valve	<ul style="list-style-type: none"> A. Valve coil open B. Open valve wire C. Bad control (check 24Vac voltage between V1 & V2)
6. Flame sense during Trial For Ignition, but no flame sense after TFI	<ul style="list-style-type: none"> A. Bad electrode B. Bad HV igniter wire C. Poor ground at burner D. Poor flame (check flame current)

22. TROUBLESHOOTING GUIDE - HEATER OPERATION



WARNING

Improper adjustment, alteration, service or maintenance can cause property damage, injury or death. This heater must be

SEQUENCE OF EVENTS (also see DSI Troubleshooting previous page)

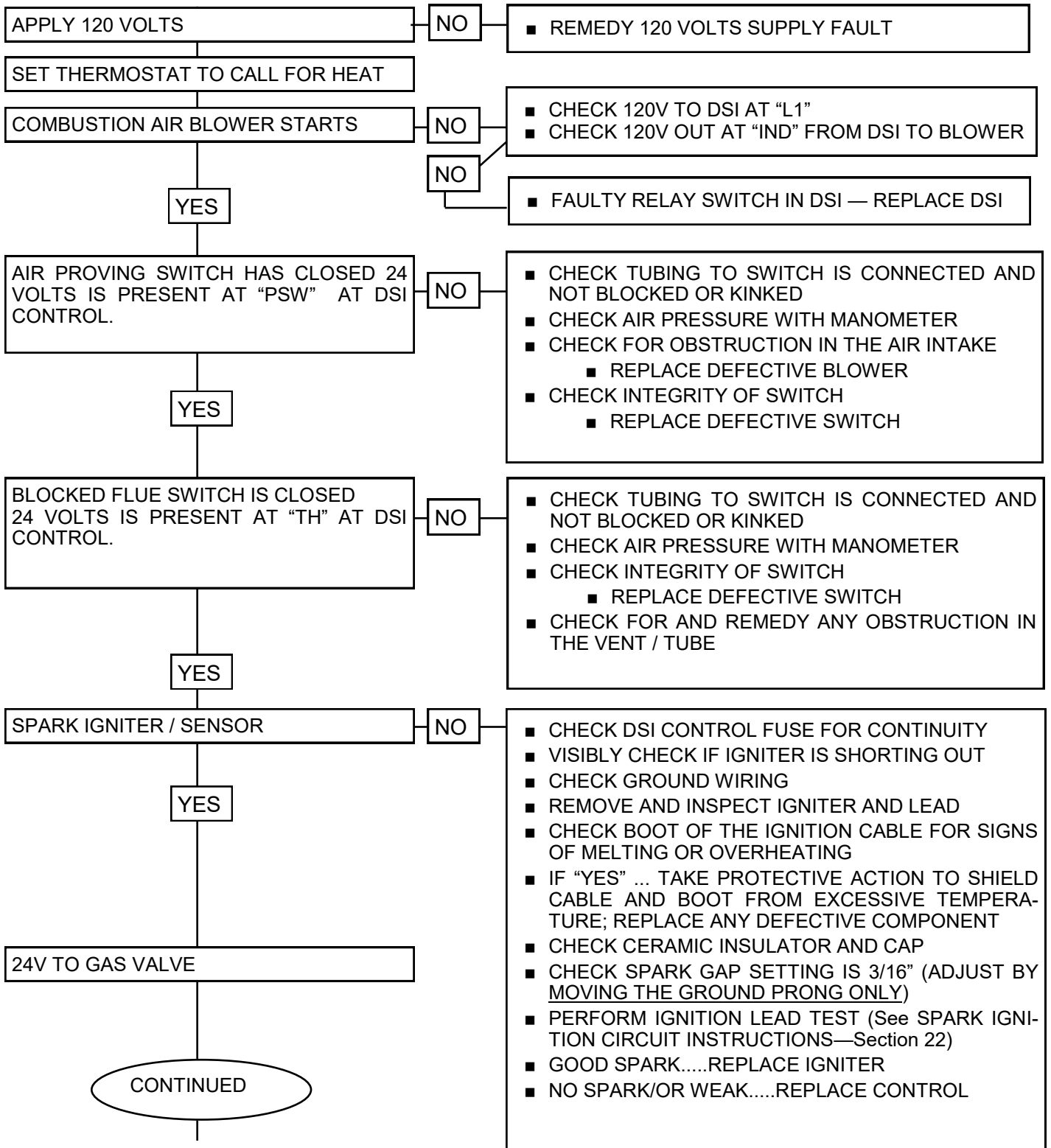

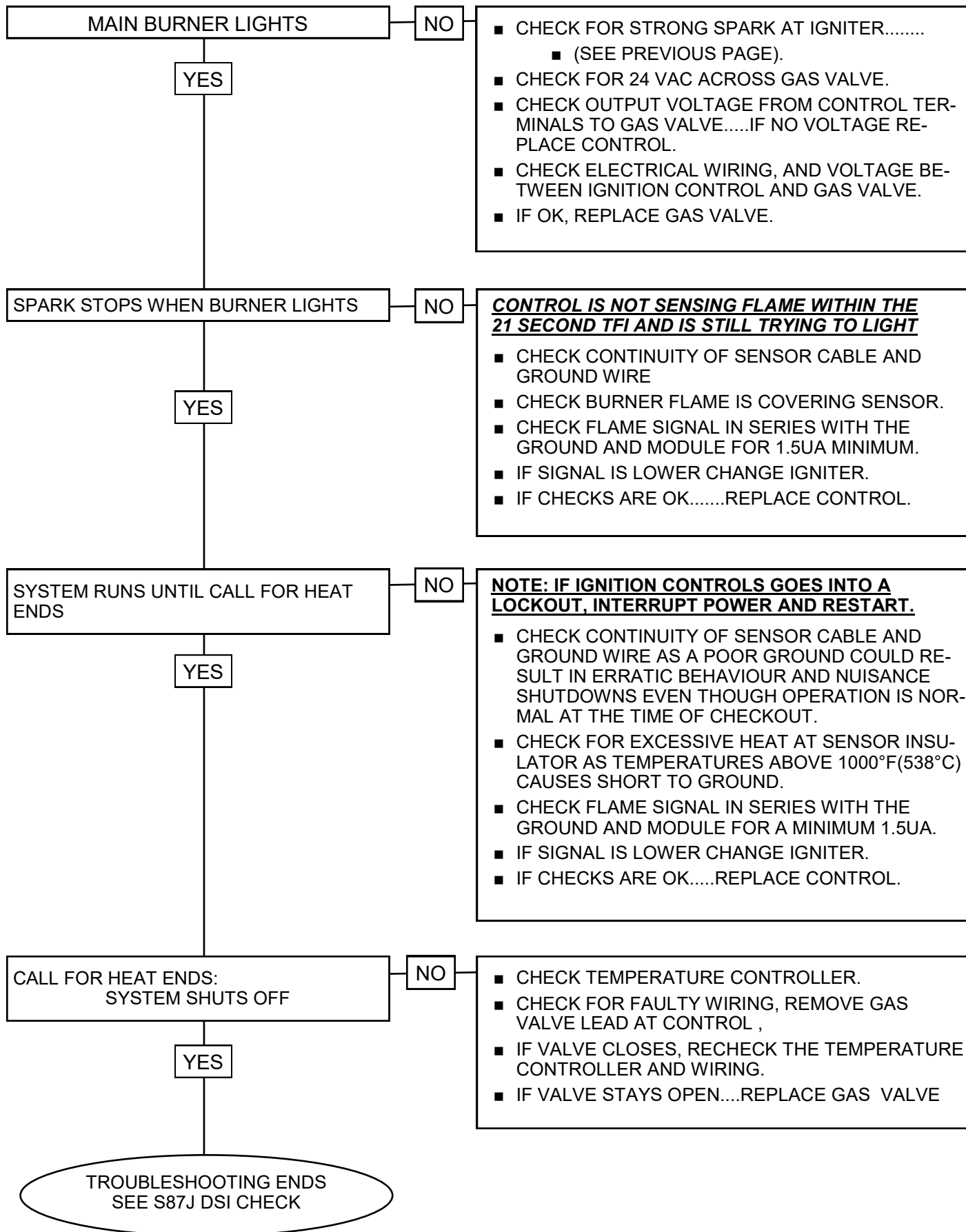

23. START-UP / COMMISSIONING SHEET



THIS EQUIPMENT HAS BEEN FACTORY FIRED AND TESTED PRIOR TO SHIPMENT. HOWEVER, THIS APPLIANCE IS NOT “PLUG & PLAY”. IT REQUIRES COMMISSIONING AND FIELD ADJUSTMENT / SPECIFICATIONS CONFIRMATION TO ENSURE SAFE AND EFFICIENT OPERATION.

**COMMISSIONING REPORT
AS PER I&O MANUAL AND LOCAL/NATIONAL CODES**

CONTRACTOR: _____

STREET: _____

CITY: _____ STATE/PROV: _____ ZIP: _____

PHONE: _____ CELL: _____

JOB NAME: _____

CITY: _____ STATE/PROV: _____

HEATER MODEL NUMBER : _____

Located on burner rating plate

HEATER SERIAL NUMBER : _____

Located on burner rating plate

TO ENSURE THAT SITE CONDITIONS ARE COMPATIBLE WITH THE HEATER’S PERFORMANCE AND TO ALLEVIATE NUISANCE CALL-BACKS, THE COMMISSIONING REPORT (next page) NEEDS TO BE COMPLETED BY THE QUALIFIED GAS INSTALLER.

A CALL FOR TECHNICAL SUPPORT MUST PROVIDE THE INFORMATION FROM THE COMPLETED COMMISSIONING REPORT ON THE NEXT PAGE

TECHNICAL SERVICES:

FAX: 1-866-361-0523,

PHONE: 1-877-686-3779



WARNING

START UP ‘SMOKE’

During start up, material coatings used in the production process of tubes and reflectors will “burn off” and create smoke during the first hour of operation. This is temporary and normal. Please ensure that there is sufficient ventilation to adequately clear the smoke from the space. Notify site and safety personnel to ensure that alarm systems are not unduly activated.

QUALIFIED INSTALLER TO COMPLETE THIS TUBE HEATER COMMISSIONING REPORT

REFER TO THIS COMPLETED REPORT WHEN CALLING TECHNICAL SERVICES: 1-877-446-3727

TYPE OF GAS	NG	<input type="checkbox"/>	LP	<input type="checkbox"/>
HAS A MANUFACTURER'S GAS CONVERSION KIT BEEN INSTALLED	YES	<input type="checkbox"/>	NO	<input type="checkbox"/>
DOES BUILDING HAVE A 'NEGATIVE AIR' CONDITION	YES	<input type="checkbox"/>	NO	<input type="checkbox"/>
IS HEATER EXPOSED TO CHEMICAL OR CORROSIVE ATMOSPHERE	YES	<input type="checkbox"/>	NO	<input type="checkbox"/>
■ IS 'OUTSIDE COMBUSTION AIR' REQUIRED TO THE BURNER	YES	<input type="checkbox"/>	NO	<input type="checkbox"/>
MINIMUM CLEARANCES CONFORM TO REQUIREMENTS OF THIS MANUAL	YES	<input type="checkbox"/>	NO	<input type="checkbox"/>
WHAT IS THE ALTITUDE OF THIS PROJECT LOCATION ABOVE SEA LEVEL	<input type="text"/>		FEET	
■ IS ALTITUDE ADJUSTMENT REQUIRED? (See Section 27, Page 47)	YES	<input type="checkbox"/>	NO	<input type="checkbox"/>
CAN HEATER BE AFFECTED BY OVERHEAD CRANES / VIBRATION	YES	<input type="checkbox"/>	NO	<input type="checkbox"/>
THE GAS SUPPLY PIPING IS ADEQUATELY SIZED FOR SYSTEM VOLUME	YES	<input type="checkbox"/>	NO	<input type="checkbox"/>
GAS SUPPLY LINES AND BRANCHES HAVE BEEN PURGED OF AIR	YES	<input type="checkbox"/>	NO	<input type="checkbox"/>
INLET GAS SUPPLY PRESSURE WITH ALL HEATERS OPERATING	<input type="text"/>		" WC	
MANIFOLD PRESSURE WITH HEATER OPERATING	<input type="text"/>		" WC	
LINE VOLTAGE READING AT THE HEATER	<input type="text"/>		VOLTS	
VOLTAGE READING AT IGNITION MODULE	<input type="text"/>		VOLTS	
IS THE HEATER PROPERLY ELECTRICALLY GROUNDED	YES	<input type="checkbox"/>	NO	<input type="checkbox"/>
FLAME SIGNAL STRENGTH FROM SENSOR (μ A microamps)	<input type="text"/>		μ A	
IS THE HEATER CONTROLLED BY A THERMOSTAT	YES	<input type="checkbox"/>	NO	<input type="checkbox"/>
IS THE THERMOSTAT STRATEGICALLY LOCATED	YES	<input type="checkbox"/>	NO	<input type="checkbox"/>
'MAXIMUM STACK HEIGHT' SIGN(S) POSTED AT THERMOSTAT(S)	YES	<input type="checkbox"/>	NO	<input type="checkbox"/>
TOTAL LENGTH OF LOW VOLTAGE THERMOSTAT WIRE	<input type="text"/>		FEET	
GAUGE OF THE LOW VOLTAGE THERMOSTAT WIRE	<input type="text"/>		GAUGE	
WHAT IS THE HEATER TUBE LENGTH (10 ft per tube section)	<input type="text"/>		FEET	
WHAT IS THE TOTAL LENGTH OF THE VENT (Add 5 ft for each 90° elbow)	<input type="text"/>		FEET	
WHAT LENGTH IS THE COMBUSTION AIR DUCT (Add 5 ft for each 90° elbow)	<input type="text"/>		FEET	
WHAT IS THE TOTAL TURBULATOR LENGTH (See Section 26, Pages 45-46)	<input type="text"/>		INCHES	
IS THE TURBULATOR IN THE PROPER LOCATION IN THE SYSTEM (Page 46)	YES	<input type="checkbox"/>	NO	<input type="checkbox"/>
THIS HEATER TEST FIRED WITHOUT MALFUNCTION	YES	<input type="checkbox"/>	NO	<input type="checkbox"/>

24. MODEL BTUH INPUT RATINGS AND CORRESPONDING DIMENSIONS

SET / ITT MODEL	HIGH-FIRE INPUT (BTUH)	LOW-FIRE INPUT (BTUH)	SET / ITT MODEL	NOMINAL TUBE LENGTH (FT)	OVERALL HEATER LENGTH * (FT)	APPROX NET WEIGHT ** (LBS)
200/140	195,000	140,000	200/140	60	60'	282
				50	50' 4"	239
175/125	162,000	115,000	175/125	60	60'	282
				50	50' 4"	239
155/110 NG	150,000	110,000	155/110	50	50' 4"	239
155/110 Propane	145,000	100,000		40	40' 8"	197
130/90 NG	120,000	85,000	130/90	30 & 40	40' 8"	197
130/90 Propane	117,000	77,000	130/90	40 ONLY	31'	154
110/75 NG	110,000	80,000	110/75	40	40' 8"	197
110/75 Propane	108,000	70,000		30	31'	154
80/60 NG	78,000	58,000	80/60	30	31'	154
80/60 Propane	78,000	52,000		20	21' 4"	111

→ Packaged in 10 ft lengths.

→ Swaged tube has approximate 4 inch overlap -

- Net length of first and intermediate tubes is 116 inches
- Last tube is 120" (the 4 inch swage length is exposed for vent connection)
- Total tube length is approximately 4 inches shorter for each multiple of 10 feet

* Overall heater length includes: Burner length + All Tubes length

** Burner weight is 26 pounds (11.8 kg)

Each 10 ft tube/reflector section weighs 82 pounds (37.2 kg)

FIGURE 21 BURNER DIMENSIONS

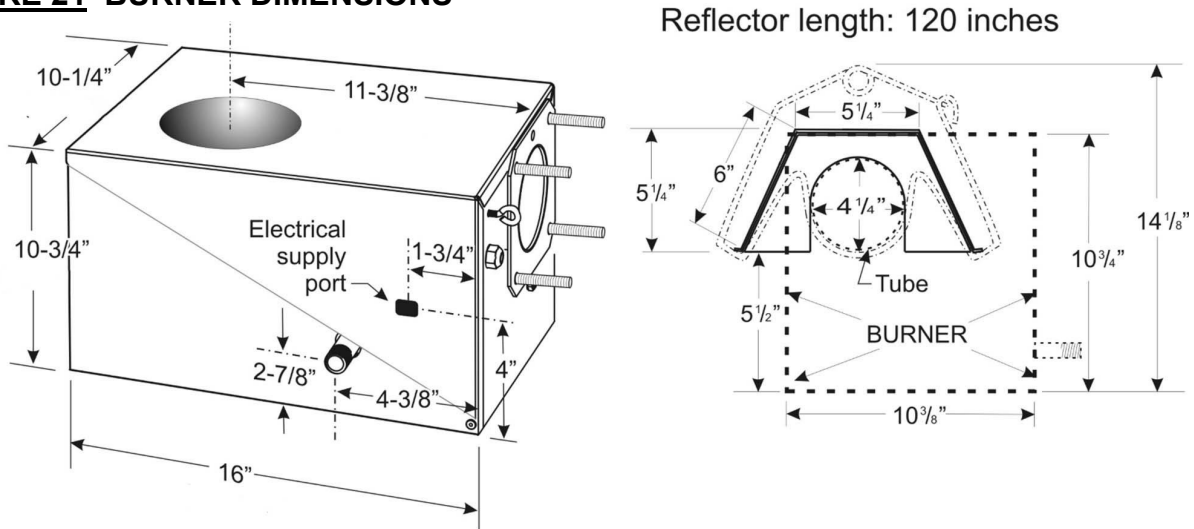
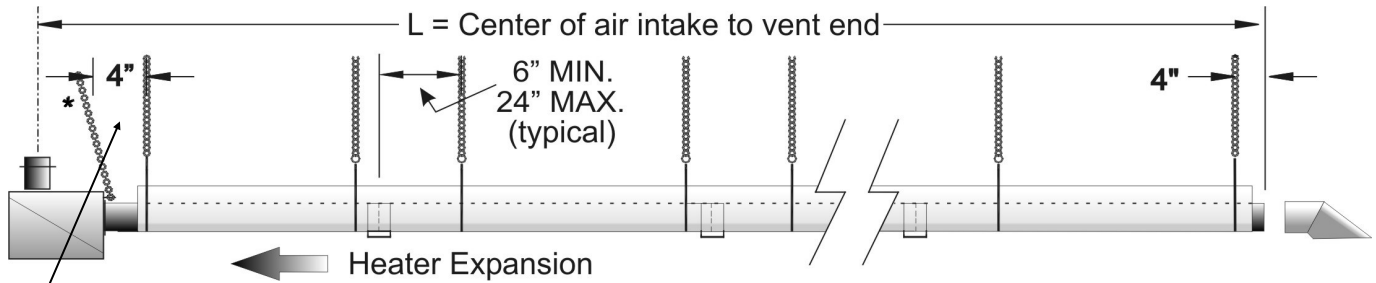

FIGURE 22 HANGER SPACING / LENGTH - AIR INTAKE TO VENT END



- POSITION BURNER END HANGER 4 INCHES (10 CM) FROM BURNER
- LOCATE SYSTEM HANGERS NO LESS THAN 6 INCHES (15 CM) AND NO MORE THAN 24 INCHES (61 CM) FROM TUBE COUPLING
- * ANGLE BURNER SUPPORT CHAIN BACK OVER BURNER - ALLOWS TUBE SYSTEM EXPANSION

<u>Tube Length</u>	<u>'L' = center air intake to vent end</u>	<u>Tube Length</u>	<u>'L' = center air intake to vent end</u>
20'	20'-11 3/4" ; 251 3/4"	50'	49'-11 3/4" ; 599 3/4"
30'	30'-7 3/4" ; 367 3/4"	60'	59'-7 3/4" ; 715 3/4"
40'	40'-3 3/4" ; 483 3/4"		

25A. BURNER & TUBE KIT ASSEMBLY CHART MODELS SET / ITT

MODELS SET & ITT are approved for indoor commercial / industrial non-residential applications. For outdoor, wet and harsh environment applications refer to models SPW-JZ / IWP (powder coated burner box) and/or STW-JZ / IW (stainless steel burner box).

	BEFORE INSTALLING: ENSURE you have the CORRECT TUBE KIT(s) for the BURNER INPUT
---	--



		'SET / ITT' TUBE KIT PART # & QUANTITY REQUIRED							
		Stand-Alone Kits			Primary Kits		Secondary Kits		
		120	170	210	165	165	120	165	
<i>Tube Kit Shipping Weight (lbs)</i> →									
<i>Nominal Length (ft)</i> →		20'	30'	40'	30'	30'	20'	30'	
MODEL		TM-1420-SX	TM-1430-SX	TM-1040-SX	TM-F030-SX	TM-1030-SX	TM-0020-SX	TM-0030-SX	
80/60	20'	1							
	30'		1						
110/75	30'		1						
	40'			1					
130/90 NG ONLY	30'		1						
130/90 NG & LP	40'			1					
155/110	40'			1					
	50'				1+		1	1	
175/125	50'					1+	1		
	60'					1+		1	
200/140	50'					1+	1		
	60'					1+		1	

TUBE KITS (Not emissive coated)

Stand-Alone tube kits require no additional tube kits.

Primary tube kits require at least one additional Secondary tube kit.

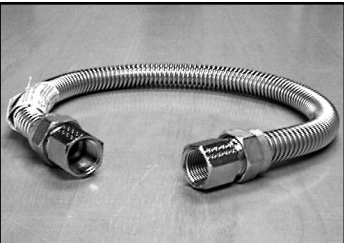
Secondary tube kit require a Primary tube kit.

FLEXIBLE GAS CONNECTOR (Included in Burner Kit) - MUST INSTALL - see Section 13	
<p>USA - Stainless Steel Flexible Gas Connector</p> <p>130,000 or less: JL-0771-XX - 1/2"x24"</p> <p>155,000 or more: JL-0771-YY - 3/4"x36"</p>	<p>CANADA - Type 1 Hose Gas Connector</p> <p>130,000 or less: JL-0771-RC - 1/2"x36"</p> <p>155,000 or more: JL-0771-RB - 3/4"x36"</p>
	

25B. BURNER & TUBE KIT ASSEMBLY CHART MODELS SETU / ITTU

MODELS SETU & ITTU are approved for indoor commercial / industrial non-residential applications. For outdoor, wet and harsh environment applications refer to models SPW-JZ / IWP (powder coated burner box) and/or STW-JZ / IW (stainless steel burner box).



BEFORE INSTALLING: ENSURE you have the CORRECT TUBE KIT(s) for the BURNER INPUT

		SETU / ITTU TUBE KIT PART # & QUANTITY REQUIRED					
		Stand-Alone **			Primary **		2ndary
Tube Kit Shipping Weight (lbs) →		100	145	170	170	170	65
Tube Length (ft) →		10' x 2	15' x 2	20' x 2	20' x 2	20' x 2	10' x 2
MODEL		TM-1410-SU	TM-1415-SU	TM-1020-SU	TM-0020-SU	TM-A120-SU	TM-0010-SU
80/60	2 x 10'	1					
	2 x 15'		1				
110/75	2 x 15'		1				
	2 x 20'			1			
130/90	2 x 15'		1				
	2 x 20'			1			
130/90 NG ONLY	2 x 20'			1			
130/90 NG & LP	2 x 30'				1+		1
175/125	2 x 30'					1+	1
200/140	2 x 30'					1+	1



** These kits include Turn Box JS-0513-BU packed and shipped in a separate carton

TUBE KITS (Not emissive coated)

Stand-Alone tube kits require no additional tube kits.

Primary tube kits require at least one additional Secondary tube kit.

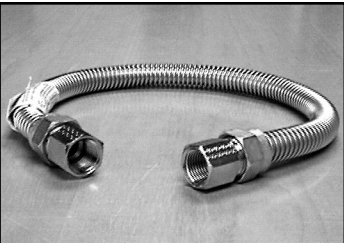
Secondary tube kit require a Primary tube kit.

FLEXIBLE GAS CONNECTOR (Included in Burner Kit) - MUST INSTALL - see Section 13	
<p>USA - Stainless Steel Flexible Gas Connector</p> <p>130,000 or less: JL-0771-XX - 1/2"x24"</p> <p>155,000 or more: JL-0771-YY - 3/4"x36"</p>	<p>CANADA - Type 1 Hose Gas Connector</p> <p>130,000 or less: JL-0771-RC - 1/2"x36"</p> <p>155,000 or more: JL-0771-RB - 3/4"x36"</p>
	

26. TURBULATORS:



NOTE: Improper location of a turbulator can cause malfunction of the heater, property damage, and will void the heater warranty.

Tube Heaters are supplied with all required turbulator(s) factory installed into the tube(s) and are clearly labeled for identification. Refer to tables below, and illustration next page for turbulator lengths and locations in system.

STRAIGHT TUBE MODELS:

MODEL	TURBULATOR LENGTH
SET / ITT 200/140 x 60	72" *
SET / ITT 200/140 x 50	40" + 72"
SET / ITT 175/125 x 50 & 60	40" + 72"
SET / ITT 155/110 x 50	24"
SET / ITT 155/110 x 40	24" + 109"
SET / ITT 130/90 x 40	24" + 109"
SET / ITT 130/90 x 30 NG ONLY	60" + 96"
SET / ITT 110/75 x 40	24" + 109"
SET / ITT 110/75 x 30	60" + 96"
SET / ITT 80/60 x 30	60" + 96"
SET / ITT 80/60 x 20	39" + 96"

U-TUBE MODELS:

MODEL	TURBULATOR LENGTH
SETU / ITTU 200/140 - 30U	72" *
SETU / ITTU 175/125 - 30U	40" + 72"
SETU / ITTU 155/110 - 20U	24" + 109"
SETU / ITTU 130/90 - 20U	24" + 109"
SETU / ITTU 130/90 - 15U NG ONLY	24" + 109"
SETU / ITTU 110/75 - 20U	24" + 109"
SETU / ITTU 110/75 - 15U	60" + 96"
SETU / ITTU 80/60 - 15U	60" + 96"
SETU / ITTU 80/60 - 10U	39" + 96"

Prior to installation:

* **200/140x60 ft:** Remove and discard 40" turbulator from the upstream end of last tube

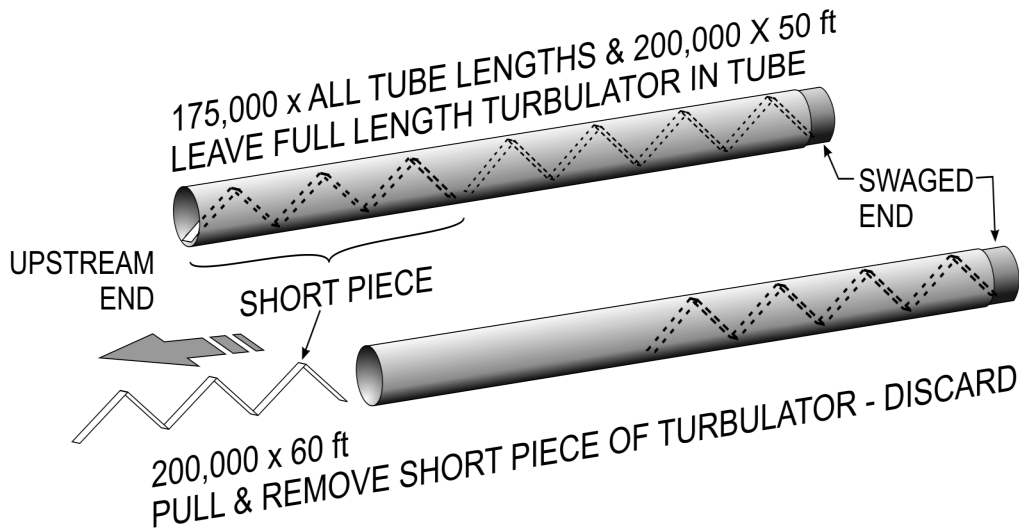

TURBULATOR LENGTH & LOCATION IN SYSTEM:

2-STAGE MODEL x LENGTH:

TUBE MATERIAL LEGEND:

A/S = ALUMINIZED STEEL
 HRS = HOT ROLLED STEEL
 S/S = STAINLESS STEEL

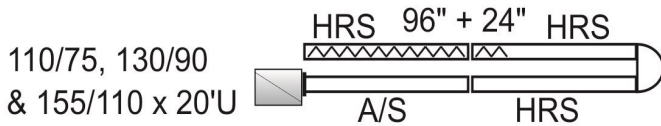
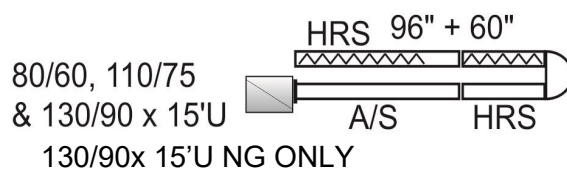
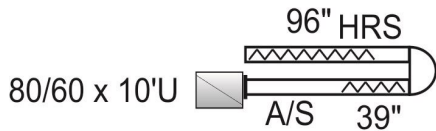
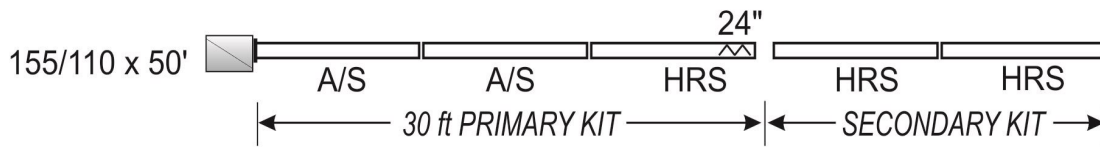
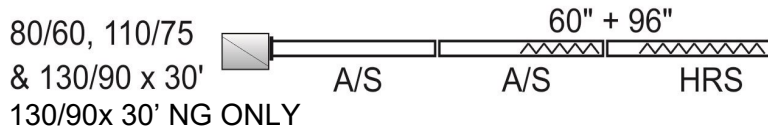

NOTE: FOR FOLLOWING MODELS THE TUBE WITH TURBULATOR(S) IS PACKAGED IN THE 30 FT PRIMARY TUBE KIT BUT IS INSTALLED AT THE VENT END OF THE SYSTEM

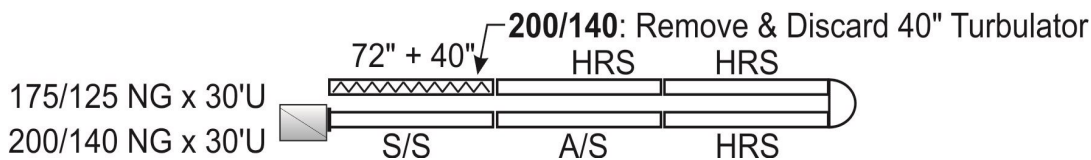

27. HIGH ALTITUDE INSTALLATION

When this appliance is installed above the altitude stipulated below, the input must be de-rated by 4% for each 1000 ft . **If your local utility supplies gas with a de-rated heat content, no orifice change is required in the heater** . Check with your local utility regarding de-rating, and the following specifically for country of installation:

USA: The factory installed orifice for this appliance is approved for altitudes zero to 2000 feet above sea level. Installation beyond 2000': Please refer to ANSI Z223.1 National Fuel Gas Code, which requires to de-rate 4% per 1000' above sea level.

Canada: The factory installed orifice for this appliance is approved for altitudes zero to 4500 feet above sea level. When installed above 4500 feet, refer to the Local Provincial Authority having jurisdiction.

Also refer to 'Total System Length Restrictions' for altitudes above 4500 ft on next page.

SCHWANK/INFRAVE RECOMMENDED ORIFICE CHART - ALTITUDE CONVERSION

SET / ITT MODEL	FOR USE AT ALTITUDES GREATER THAN (FEET) Gas Orifice Drill Size / Part#							
	Supplied 0 - 2000 ft	USA Only			USA & CANADA*			
		> 2000	> 3000	> 4000	> 4500	> 6000	> 7000	> 8000
80/60 NG	# 17 JS-0717-DM	#19 JS-0719-DM	# 19 JS-0719-DM	# 20 JS-0720-DM	# 20 JS-0720-DM	# 22 JS-0722-DM	# 23 JS-0723-DM	# 24 JS-0724-DM
80/60 Propane	# 38 JS-0738-DM	# 40 JS-0740-DM	# 41 JS-0741-DM	# 41 JS-0741-DM	3/32" JS-0709-IN	# 42 JS-0742-DM	# 42 JS-0742-DM	# 43 JS-0743-DM
110/75 NG	# 3 JS-0703-DM	# 5 JS-0705-DM	# 6 JS-0706-DM	# 7 JS-0707-DM	# 8 JS-0708-DM	# 10	# 11 JS-0711-DM	3/16" JS-0719-IN
110/75 Propane	# 31 JS-0731-DM	# 32 JS-0732-DM	# 32 JS-0732-DM	# 33 JS-0733-DM	# 34 JS-0734-DM	# 35 JS-0735-DM	# 36 JS-0736-DM	# 36 JS-0736-DM
130/90 NG	# 1 JS-0701-DM	# 2 JS-0702-DM	7/32" JS-0722-IN	# 3 JS-0703-DM	# 3 JS-0703-DM	# 4 JS-0704-DM	# 6 JS-0706-DM	# 7 JS-0707-DM
130/90 Propane 40 ft ONLY	# 30 JS-0730-DM	1/8" JS-0713-IN	1/8" JS-0713-IN	# 31 JS-0731-DM	# 31 JS-0731-DM	# 32 JS-0732-DM	# 32 JS-0732-DM	# 33 JS-0733-DM
155/110 NG	1/4" JS-0725-IN	# C JS-070C-NS	# B JS-070B-NS	15/64" JS-0723-IN	# A JS-070A-NS	# 1 JS-0701-DM	# 2 JS-0702-DM	# 2 JS-0702-DM
155/110 Propane	9/64" JS-0714-IN	# 29 JS-0729-DM	# 29 JS-0729-DM	3.4 mm JS-0734-MM	3.3 MM JS-0733-MM	3.3 MM JS-0733-MM	1/8" JS-0713-IN	1/8" JS-0713-IN
175/125 NG	6.7 mm JS-0767-MM	# F JS-070F-NS	1/4" JS-0725-IN	1/4" JS-0725-IN	# D JS-070D-NS	# C JS-070C-NS	# B JS-070B-NS	# A JS-070A-NS
200/140 NG	# N JS-070N-NS	# M JS-070M-NS	# L JS-070L-NS	# L JS-070L-NS	# K JS-070K-NS	# J JS-070J-NS	# I JS-070I-MM	17/64" JS-0727-IN

27. HIGH ALTITUDE INSTALLATION - Total System Length Restrictions

NOTE: Installations above 4,500 ft: Restrict the Total Combined System Length as indicated in the TOTAL SYSTEM LENGTH RESTRICTIONS Table below.

MINIMUM VENT LENGTH: (Vented or Unvented (indirect mechanical ventilation))

- Minimum vent length of 3 ft is required (**NOTE:** 200,000 Propane: Minimum 8 ft)

HIGH ALTITUDE MAXIMUM SYSTEM LENGTH (above 4,500 ft) :



includes: Tube Heater length + combustion air duct + vent:



- Each 90° elbow in the system has an equivalent length of 5 ft.
- A maximum of 2 elbows are allowed in any portion (duct, tube heater, vent) with the exception of up to three 90° elbows in a vertical vent run through the roof
- Combustion air duct may be 4" or 5" diameter and is not to exceed lengths in table below
- Exceeding the allowable lengths in the table below can create combustion and/or condensation problems and will void CSA Certification and the heater warranty.
- Do not exceed the **Maximum Combined System Length** regardless of the allowed maximum length of individual vent or combustion air duct

TOTAL SYSTEM LENGTH RESTRICTIONS: INSTALLATIONS ABOVE 4,500 FEET (Lower altitudes refer to Section 11A)

SET / ITT Model	Do Not Exceed Max. Combined System Length*		Max. Vent Length* Individual: 4" Ø Combined: 6" Ø	Max. Air Duct Length* (by Duct Diameter)		Example
	With 4" Ø Air Duct	With 5" Ø Air Duct		4" Ø	5" Ø	
80 / 60	60 ft	80 ft	Up to 20 ft	20 ft	40 ft	155/110 Model: Tube Heater Length 40 ft 1 x 90° elbow (vent) 5 ft Straight vent 15 ft 1 x 90° elbow (duct) 5 ft Air Duct: 4" Ø <u>13 ft</u> Combined Length 78 ft Max. Allowed 80 ft Up To Additional 20' if 5"Ø Air Duct
110 / 75	80 ft	100 ft	Up to 30 ft	20 ft	40 ft	
130 / 90	80 ft	100 ft	Up to 30 ft	20 ft	40 ft	
155 / 110	80 ft	100 ft	Up to 30 ft	30 ft	50 ft	
175 / 125	100 ft	120 ft	Up to 40 ft	30 ft	50 ft	
200 / 140	-	120 ft	Up to 40 ft	Use 5"Ø	50 ft	

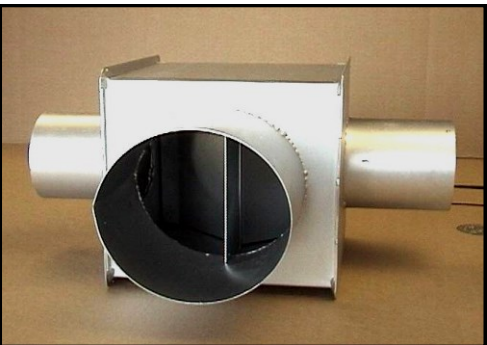
28. OPTIONAL ACCESSORIES

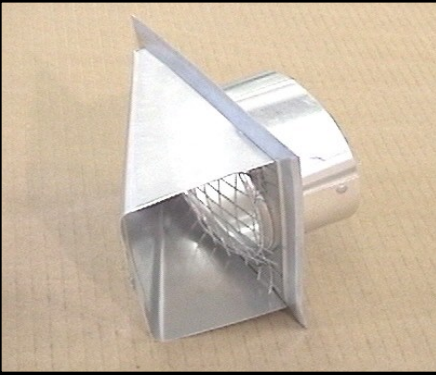
<p>#2 Lion Chain (115 lb work load) - 200 ft roll</p> <p>'S' Hooks - 1 7/8" - package of 25</p>	<p>JL-0800-XX</p> <p>JL-0798-SH</p>	
<p>Flue Vent Terminal</p> <p>4" wall horizontal</p>	<p>JA-0528-XX</p>	
<p>Torctite Coupler</p> <p>Sufficient quantity supplied with heater</p> <p>Use for connection of vent tee, or replacement part</p>	<p>JA-0516-SW</p>	
<p>Vent Tee 4" X 4" X 6"</p> <p>(Couplers optional - see above)</p>	<p>JA- 0514-XX</p>	

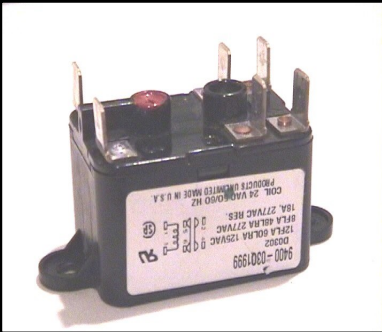
<p>Fresh Air Intake Adapter</p>	<p>JS-0532-SE</p>	
<p>Fresh Air Intake Cap—Wall</p>	<p>JS-0532-VC</p>	
<p>Fresh Air Intake Cap—Roof 4" roof cap</p>	<p>JA-0530-XX</p>	
<p>2-Stage Low Voltage Digital Thermostat (24 Volts - °F or °C selectable) <i>Not for use in corrosive or wet environments</i></p>	<p>JS-0569-DT</p>	
<p><u>Required For MULTIPLE HEATERS per Thermostat:</u></p>		
<p>24V RELAY SWITCH <u>Multiple Tube Heaters</u> controlled by a single 2-Stage Thermostat (field installed)</p>	<p>JS-0568-CC</p>	

90 degree Aluminized Steel Elbow Kit

(Kit includes: aluminized steel elbow, coupler, and two reflector end caps)

For 180° elbow use two x JS-0508-SM, or use Model SETU / ITTU that includes 180° Turn Box

JS-0508-SM



90° Elbow Kit JS-0508-SM

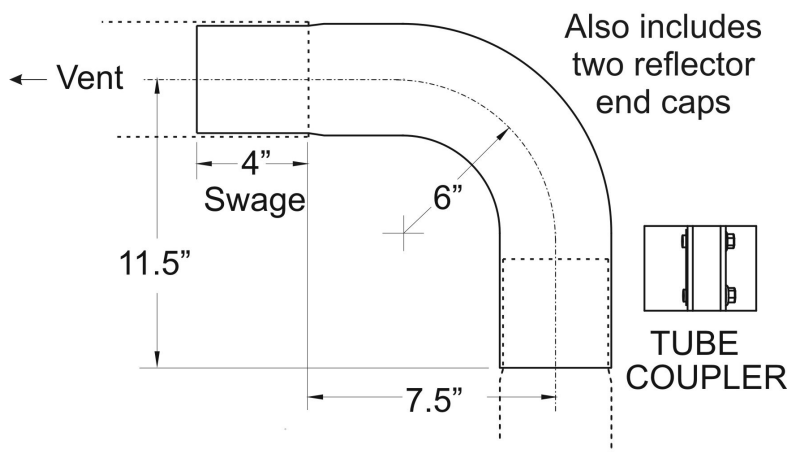

Side Reflector Extension Kit-
10" deep, 10 ft long Each
Includes 3 'S' Hooks

JS-0509-KT

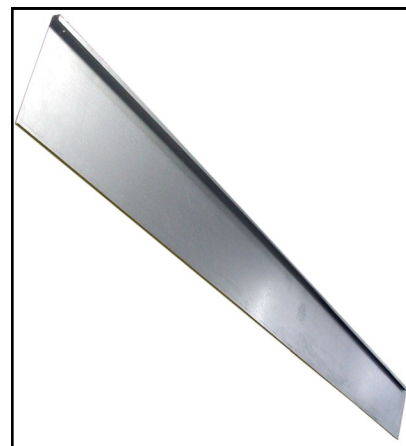

Tube Protection Screen
-5 foot lengths

JA-0780-XX

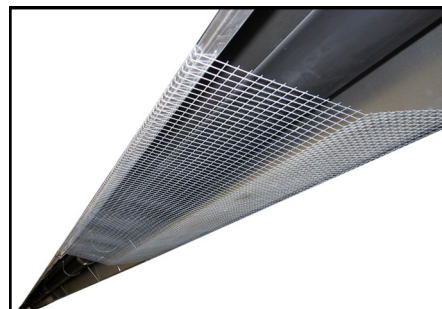

29. REPLACEMENT PARTS

SET / ITT Series Burner

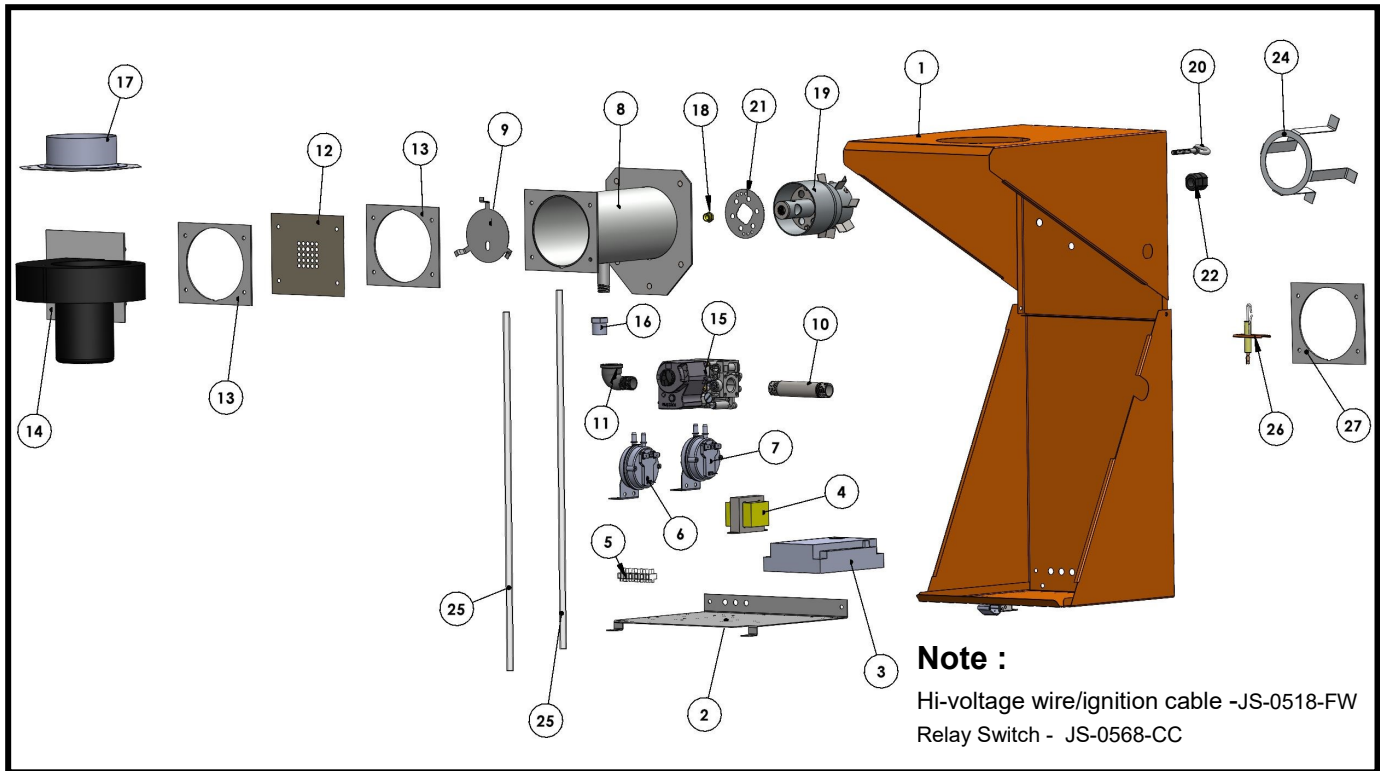

#	PART DESCRIPTION	MODEL	MODEL DASH #/ GAS TYPE	PART #	PART DESCRIPTION PRIMARY
1	BURNER HOUSING	ALL	Schwank	JS-0582-XX	Burner housing coated orange
		ALL	Infrasave	JJ-0582-XX	Burner housing coated gray
2	COMPONENT PLATE	ALL		JS-0581-SE	Component mounting plate SE
3	FENWAL DSI CONTROL	ALL		JA-0567-XX	Control, 24 Vac
3	FENWAL REPLACES S87J :REPLACEMT KIT	ALL		JA-0567-RK	Fenwal Control + Wire Harness + Cable + Ignitor
4	TERMINAL BLOCK	ALL		JM-0455-DD	Terminal block
5	STEP DOWN TRANSFORMER	ALL		JA-0775-XX	Transformer 120/24V,20VA AT120B1028
6	COMBUSTION AIR PROVING SWITCH	80/60	-X,-F	JS-0575-YY	Air proving Switch 0.65" WC
		110/75	-X	JS-0575-YY	Air proving Switch 0.65" WC
		130/90	-X	JS-0575-ZB	Air proving Switch 0.90" WC
		155/110	-X	JS-0575-ZC	Air proving Switch 0.80" WC
		175/125	-X	JS-0575-ZB	Air proving Switch 0.90" WC
		200/140	-X	JS-0575-ZA	Air proving Switch 1.40" WC
		110/75	-F;NG	JS-0575-ZB	Air proving Switch 0.90" WC
		110/75	-F;LP	JS-0575-YY	Air proving Switch 0.65" WC
		130/90	-F	JS-0576-UL	Air proving Switch 1.10" WC
		155/110	-F	JS-0576-UG	Air proving Switch 1.00" WC
		175/125	-F	JS-0575-YZ	Air proving Switch 1.30" WC
		200/140	-F	JS-0575-ZL	Air proving Switch 1.50" WC

continued ...

#	PART DESCRIPTION	MODEL	MODEL DASH #/ GAS TYPE	PART #	PART DESCRIPTION PRIMARY
7	BLOCKED FLUE PRESSURE SWITCH	80/60	-X	JS-0577-SS	Blocked flue switch 0.60" WC
		110/75	-X;NG,LP	JS-0577-RR	Blocked flue switch 0.46" WC
		130/90	-X	JS-0577-TS	Blocked flue switch 0.80" WC
		155/110	-X	JS-0577-TS	Blocked flue switch 0.80" WC
		175/125	-X	JS-0577-SS	Blocked flue switch 0.60" WC
		200/140	-X	JS-0577-YA	Blocked flue switch 0.70" WC
		80/60	-F	JS-0578-UL	Blocked flue switch 1.03" WC
		110/75	-F;NG	JS-0578-UL	Blocked flue switch 1.03" WC
		110/75	-F;LP	JS-0577-RR	Blocked flue switch 0.46" WC
		130/90	-F	JS-0577-XX	Blocked flue switch 1.17" WC
		155/110	-F	JS-0577-YY	Blocked flue switch 0.90" WC
		175/125	-F	JS-0577-YY	Blocked flue switch 0.90" WC
		200/140	-F	JS-0577-YY	Blocked flue switch 0.90" WC
8	BURNER CHAMBER	ALL		JS-0504-XX	Burner Chamber
10	4" NIPPLE	ALL		JS-0590-XX	Nipple 1/2" x 4"
11	90 DEGREE ELBOW FITTING 1/2"	ALL		JS-0588-XX	Street elbow fitting 90 deg 1/2"X1/2"
12	EQUALIZER PLATE	ALL		JS-0593-XX	Outlet equalizer plate 60 to 155 LP & NG
13	BLOWER GASKET	ALL	<i>Each</i>	JS-0578-XX	Outlet blower gasket
14	BLOWER ASSEMBLY	80 to 175		JS-0579-AA	Blower Assembly 1/35 HP - 45 to 175
		200		JS-0579-ZZ	Blower Assembly 1/20 HP - 200,000
15	GAS VALVE	All	NG	JA-0506-TT	Valve gas comb 3.5"-2.2" WC 24VAC
		All	LP	JA-0506-TS	Valve gas comb 5" - 3" WC 24VAC
16	MANIFOLD BUSHING	ALL		JS-0589-XX	Manifold bushing 3/8" to 1/2"
17	AIR INLET C/W SCREEN	80/60	-X	JS-0595-AC	Air Inlet Adapter
		110/75	-X	JS-0595-AC	Air Inlet Adapter
		130/90	-X	JS-0595-EP	Air Inlet Adapter
		155/110	-X	JS-0595-EP	Air Inlet Adapter
		175/125	-X	JS-0595-AE	Air Inlet Adapter 110-200 NG & LP
		200/140	-X;NG	JS-0595-EA	Air Inlet Adapter
		80/60	-F	JS-0595-SC	Air Inlet Adapter 45
		110/75	-F;NG	JS-0595-AE	Air Inlet Adapter 110-200 NG & LP
		110/75	-F;LP	JS-0595-SC	Air Inlet Adapter 45
		130/90	-F	JS-0595-UD	Air Inlet Adapter 130/160 NG
		155/110	-F	JS-0595-AE	Air Inlet Adapter 110-200 NG & LP
		175/125	-F	JS-0595-AA	Air Inlet Adapter 110-200 NG & LP
		200/140	-F;NG	JS-0595-AA	Air Inlet Adapter 110-200 NG & LP

continued ...

#	PART DESCRIPTION	MODEL	MODEL DASH #/ GAS TYPE	PART #	PART DESCRIPTION PRIMARY
18	MAIN BURNER ORFICE	80/60	-X;NG	JS-0718-DM	Gas orifice low intensity HTR 18 DMS
		110/75	-X;NG	JS-0752-MM	Gas orifice low intensity HTR 5.2 mm
		110/75	-X;LP	JS-0731-DM	Gas orifice low intensity HTR 31 DMS
		130/90	-X;NG	JS-0758-DM	Gas orifice low intensity HTR 5.8 mm
		155/110	-X;NG	JS-0725-IN	Gas orifice low intensity HTR 1/4 inch
		175/125	-X;NG	JS-0767-MM	Gas orifice low intensity HTR 6.7 mm
		200/140	-X;NG	JS-0730-IN	Gas orifice low intensity HTR 19/64 inch
		80/60	-F;NG	JS-0717-DM	Gas orifice low intensity HTR 17 DMS
		110/75	-F;NG	JS-0703-DM	Gas orifice low intensity HTR 3 DMS
		110/75	-F;LP	JS-0731-DM	Gas orifice low intensity HTR 31 DMS
		130/90	-F;NG	JS-0701-DM	Gas orifice low intensity HTR 1 DMS
		155/110	-F;NG	JS-0725-IN	Gas orifice low intensity HTR 1/4 inch
		175/125	-F;NG	JS-0767-MM	Gas orifice low intensity HTR 6.7 mm
		200/140	-F;NG	JS-070N-NS	Gas orifice low intensity HTR # N
19	BURNER CUP	80 to 155	NG; LP	JS-0510-LP	Burner Cup
		175 to 200	NG	JS-0512-XX	Burner Cup
20	EYE BOLT	ALL		JF-1012-EB	Eye Bolt
21	BURNER CUP AIR RESTRICTOR RING	ALL	NG	JS-0596-XX	Burner Cup air rest ring 0.375
		ALL	LP	JS-0597-XX	Burner head air rest. ring .500
22	GROMMET	ALL		JP-2033-XX	Grommet - Strain Relief
24	FLAME RECTIFICATION	110	-F;NG	JS-0592-RT	Flame Rectifier 110, 130 -FB Models
		130 to 155	-F	JS-0592-RT	Flame Rectifier 110, 130 -FB Models
		175 to 200	-F	JS-0592-RZ	Flame Rectifier 200-S LP
25	PRESSURE SWITCH TUBING	ALL		JS-0572-SG	Tubing set 1/4" x 20" PVC
26	IGNITER KIT	ALL		JA-0571-KT	Igniter & gasket kit / DSI tube heater

SET / ITT TUBE SYSTEM PARTS

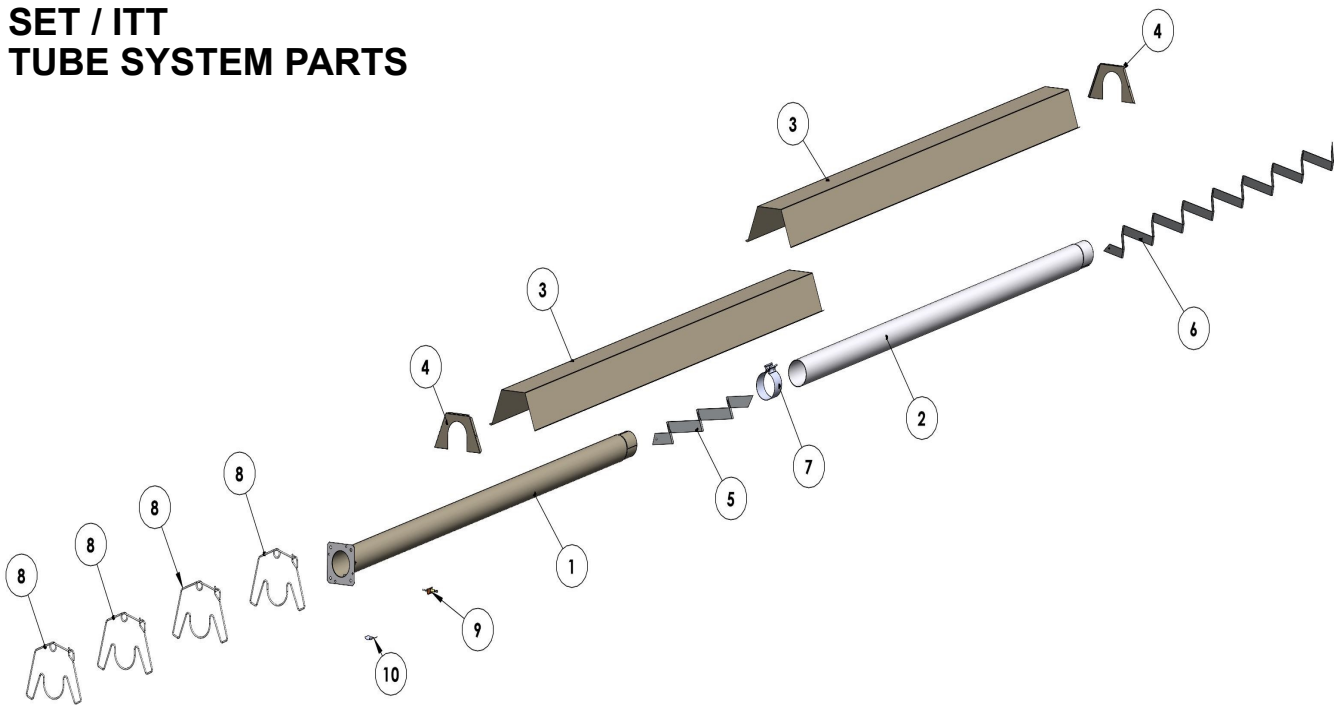

#	PART DESCRIPTION	MODEL	MODEL DASH #/ GAS TYPE	PART #	PART DESCRIPTION PRIMARY
1	FLANGED TUBES	80 to 155		JS-0501-SW-P	Flanged, Aluminized Steel tube, swaged, ports
		100 x 20FT		JS-0501-PA-P	Aluminized Steel Flanged tube, swaged, painted
		175 & 200		JS-0500-SS-P	Flanged, Stainless Steel tube, swaged, ports; replaces JS-0499-SW-P
2	SWAGED TUBES - NO FLANGE	60 to 200 x 30FT & Above		JS-0501-SW	Aluminized tube, 10' with hole for rivet
		ALL		JS-0515-SW	Steel tube 10' swaged
3	REFLECTOR	ALL		JS-0502-EM	Reflector (18" x 120")
4	END CAP	ALL		JS-0502-ES	S100 / ITB series reflector end cap
5-6	TURBULATOR (see Table 4 in Manual)			JS-0533-UA	Turbulator 24" x 1.25" - Aluminized
				JS-0533-SK	Turbulator 39" x 2" - Stainless Steel
				JS-0533-SH	Turbulator 40" x 1.25" - Aluminized
				JS-0533-SS	Turbulator 60" x 1.25" - Stainless Steel
				JS-0533-UG	Turbulator 72" x 1.25" - Aluminized
				JS-0533-SL	Turbulator 96" x 2" - Stainless Steel
				JS-0533-LG	Turbulator 109" x 1.25" - Aluminized
		100 x 20FT		JS-0535-XX	Turbulator 10' Special - 100,000 Btuh ONLY
7	COUPLER	ALL		JA-0516-SW	4" swaged tube coupler torcrite
8	WIRE HANGER	ALL		JS-0505-EH	Small wire hanger
9	IGNITER KIT	ALL		JA-0571-KT	Igniter & gasket kit / DSI tube heater
10	SIGHTGLASS ASSEMBLY	ALL		JS-0536-XX	Sight glass assembly tube heater

SETU / ITTU TUBE SYSTEM PARTS

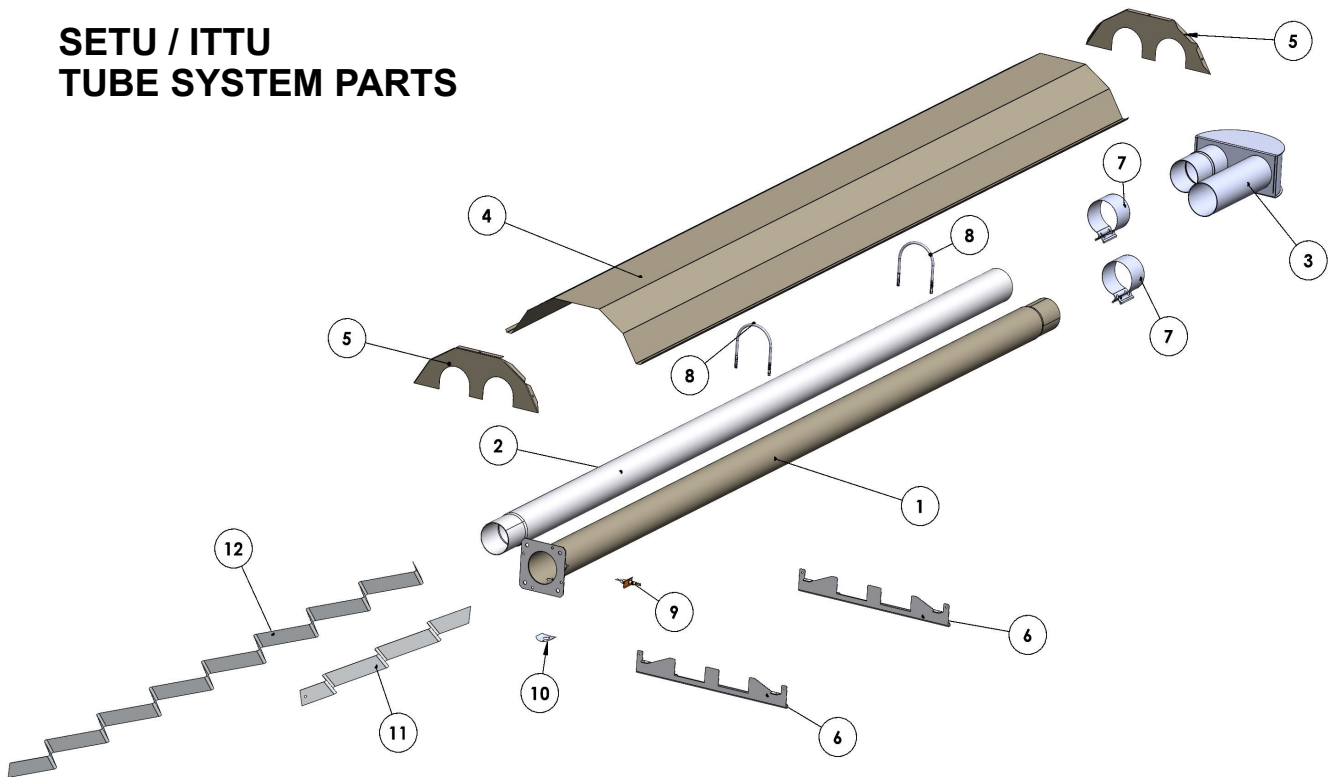

#	PART DESCRIPTION	MODEL	MODEL DASH #/ GAS TYPE	PART #	PART DESCRIPTION PRIMARY
1	FLANGED TUBES	80 to 155		JS-0501-SW-P	Flanged, Aluminized Steel tube, swaged, ports
		175 & 200		JS-0500-SS-P	Flanged, Stainless Steel tube, swaged, ports; replaces JS-0499-SW-P
2	SWAGED TUBES - NO FLANGE	175 & 200		JS-0501-SW	Aluminized tube, 10' with hole for rivet
		ALL		JS-0515-SW-P	Steel tube 10' swaged
		15FT		JS-0515-SW-5S	Steel tube 5' swaged
3	TURN BOX	ALL		JS-0513-TB	U tube turn around box
4	REFLECTOR	ALL		JS-0502-BU	Reflector (18" x 120")
				JS-0502-BU-5	Reflector (18" x 60")
5	END CAP	ALL		JS-0502-ND	S100U / ITBU series reflector end cap
6	DOUBLE STEEL HANGER	ALL		JS-0505-BU-A	U tube reflector hanger
7	COUPLER	ALL		JA-0516-SW	4" swaged tube coupler torctite
8	U- BOLT			JA-0516-UH	U Bolt 4" for U-Tube Hanger
9	IGNITER KIT	ALL		JA-0571-KT	Igniter & gasket kit / DSI tube heater
10	SIGHT GLASS ASSEMBLY	ALL		JS-0536-XX	Sight glass assembly tube heater
11-12	TURBULATOR (see Table 4 in Manual)			JS-0533-UA	Turbulator 24" x 1.25" - Aluminized
				JS-0533-SK	Turbulator 39" x 2" - Stainless Steel
				JS-0533-SH	Turbulator 40" x 1.25" - Aluminized
				JS-0533-SS	Turbulator 60" x 1.25" - Stainless Steel
				JS-0533-UG	Turbulator 72" x 1.25" - Aluminized
				JS-0533-SL	Turbulator 96" x 2" - Stainless Steel
				JS-0533-LG	Turbulator 109" x 1.25" - Aluminized



LIMITED WARRANTY CERTIFICATE



FOR GAS-FIRED INFRA-RED LOW INTENSITY TUBE HEATERS: SET / SETU & ITT / ITTU SERIES

The Manufacturer warrants that this product is free from defects in material or workmanship under normal use and service subject to the terms of this document.

TWO YEAR WARRANTY

Subject to the conditions and limitations stated herein, during the term of this limited warranty, we will supply any component part (at our option a new or repaired component part) of the heater as defined below, excluding any labor, which the Manufacturer's examination determines to be defective in workmanship or material for a period of two years (2 years) from the date of installation, unless otherwise specified below. This warranty applies to the heater's original owner, and subsequent transferees and only if the unit is installed and operated in accordance with the printed instructions accompanying the unit and in compliance with all applicable installation codes and good trade practices. Warranty is only applicable to Schwank components, other parts are limited to their own Manufacturers warranty period of one year (1 year).

FIVE YEAR WARRANTY

The Manufacturer warrants the burner sub-assembly comprising of ceramic and immediate metal tubing, and the radiating tubes (excluding couplings) for a period of five years (5 years).

WHAT IS NOT COVERED

The Manufacturer shall not be responsible for any expenses, including service, labor, diagnosis, analysis, material or transportation charges incurred during removal or reinstallation of this product, or any of its components or parts. All labor or service charges shall be paid by the owner. This warranty does not cover heating products improperly installed, misused, exposed to or damaged by negligence, accident, corrosive or contaminating atmosphere, water, excessive thermal shock, impact, abrasion, normal wear due to use, alteration or operation contrary to the owner's manual or if the serial number has been altered, defaced or removed. This warranty shall not apply if the input to the heating product exceeds by more than 2% of the rated input on the rating plate. The Manufacturer shall not be liable for any default or delay in performance by its warranty caused by any contingency beyond its control, including war, government restrictions, or restraints, strikes, fire, flood, acts of God, or short or reduced supply of raw materials or products.

WARRANTY PROCEDURE

To establish the installation date for any purpose under this Limited Warranty, you must retain the original records that can establish the installation date of your unit. If you do not provide such documents, the start date of the term of this Limited Warranty will be based upon the date of unit manufacture, plus thirty (30) days. Failure to maintain the equipment through regular annual service maintenance by a qualified service technician shall void the warranty.

LIMITATIONS AND EXCLUSIONS

This document contains all warranties made by the Manufacturer and may not be varied, altered or extended by any person. There are no promises, or agreements extending from the Manufacture other than the statements contained herein. THIS WARRANTY IS IN LIEU OF ALL WARRANTIES EXPRESSED OR IMPLIED, TO THE EXTENT AUTHORIZED BY THE LAWS OF THE JURISDICTION, INCLUDING SPECIFICALLY THE WARRANTIES OR MERCHANTABILITY OF FITNESS FOR A PARTICULAR PURPOSE.

It is understood and agreed that the Manufacturer's obligation hereunder is limited to repairing or replacing parts determined to be defective as stated above. In no event shall the Manufacturer be responsible for any alleged personal injuries or other special, incidental or consequential damages. As to property damages, contract, tort or other claim the Manufacturer's responsibility shall not exceed the purchase price paid for the product.

All replacement parts will be warranted for the unused portion of the warranty coverage period remaining on the applicable unit.

Some Authorities do not allow certain warranty exclusions or limitations on duration of warranty or the exclusions or limitations of incidental or consequential damages. In such cases, the above limitations or exclusions may not apply to you and are not intended to do so where prohibited by law. This warranty gives you specific legal rights. You may also have other rights which vary by jurisdiction.

SCHWANK
2 SCHWANK WAY, WAYNESBORO, GEORGIA. 30830
5285 BRADCO BLVD. MISSISSAUGA, ON, L4W 2A6

Ph: 1-877-686-3779
www.SchwankGroup.com

Fax: 1-866-361-0523
www.InfraSave.com