

Owner's Manual

FE2 Series

Electric Forced Air Heaters for Hazardous Locations



This manual covers the installation, maintenance, repair and replacement parts.

CCI Thermal Technologies Inc.
5918 Roper Road
Edmonton, Alberta
T6B 3E1 Canada

 IIC G Ex d IIB T3 Gb
DEMKO 10 ATEX 0910365X
-20°C (-4°F) ≤ Tamb ≤ 40°C (104°F)

MODEL CODING

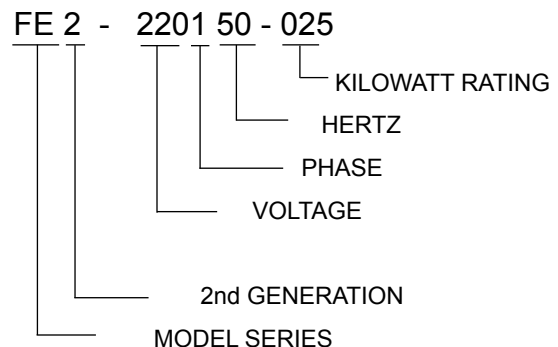

WARNING!
READ ALL IMPORTANT NOTICES

Part No. 10525.Rev.8.01

Issue Date: May 2014

Printed in Canada

RuffneckTM and VacuCore[®] are registered trademarks of CCI Thermal Technologies Inc.
Copyright[®] 2014. All rights reserved.



HEATER MAINTENANCE CHECKLIST

For Electric Forced Air Heaters

Photocopy
this page
for reuse.

Heater Model: _____ Serial No.: _____

Date of Maintenance: _____ Maintenance Done By: _____

Comments: _____

WARNING

Disconnect heater from power supply at fuse box before opening enclosures or servicing heater.
Lock the switch in the "OFF" (open) position and/or tag the switch to prevent unexpected power application.
Verify that power has been disconnected at fuse box or main panel. Lock the switch in the "OFF" (open) position
and/or tag the switch to prevent unexpected power application.
This heater should only be serviced by personnel with heating and hazardous location equipment experience.

PREVENTATIVE MAINTENANCE GRID

		Regular Service				Severe Service			
		Annual Start Up	1 Month	3 Month	12 Month	Annual Start Up	1 Month	3 Month	12 Month
Clean:									
<ul style="list-style-type: none"> ▪ Finned Tubes ▪ Fan ▪ Fan Guard ▪ Motor ▪ Louvers 	Remove dust using compressed air. Do not spray with water or solvents. Do not immerse in water or solvents.	X				X		X	
Electrical									
Check all terminal connections and conductors.	Tighten loose connections. Replace conductors with damaged insulation & frayed wiring. For drilling rigs, this should be done with every rig re-location.	X			X	X		X	
Inspect contactor contacts.	If badly pitted, burned or welded shut, replace with factory supplied contactor. For drilling rigs, this should be done with every rig re-location.	X				X		X	
Check Fuses	The Correct fuse rating and type are printed on the circuit board. Always ensure a backup fuse is available on the PCB. For drilling rigs, this should be done with every rig re-location.	X				X			
Mechanical									
Check for fluid leakage	Inspect the Pressure Release Valve label indicator for signs of rupture and degradation. If any fluid leakage occurs from the heater, disconnect it from the power supply and have the core replaced immediately. For drilling rigs, this should be done with every rig re-location.	X				X		X	
Check all enclosures	The interiors of each enclosure must be clean, dry and free of foreign materials. For drilling rigs, this should be done with every rig re-location.	X				X		X	
Check motor shaft bearing play	If the motor does not run quietly and smoothly and has excessive play replace the motor. For drilling rigs, this should be done with every rig re-location.	X				X		X	

PERIODIC (before and as required during heating season)

- | | |
|---|--|
| <p>1. CLEAN</p> <ul style="list-style-type: none"> <input type="checkbox"/> Finned Tubes <input type="checkbox"/> Fan <input type="checkbox"/> Fan Guard <input type="checkbox"/> Motor <input type="checkbox"/> Louvers | <p>2. CHECK</p> <ul style="list-style-type: none"> <input type="checkbox"/> Motor for smooth, quiet operation <input type="checkbox"/> Louvers for proper angle and tightness <input type="checkbox"/> All explosion-proof covers for tightness <input type="checkbox"/> Pressure relief device for signs of leakage. See Figure 1 and refer to the ANNUAL Section (see below) item 2 for further instructions |
|---|--|

**Remove dust using compressed air. Do not spray with water or solvents.
Do not immerse in water or solvents.**

ANNUAL (before heating season)

1. ELECTRICAL
 - Check all terminal connections and conductors.** Tighten loose connections. Conductors with damaged insulation must be replaced.
 - Inspect contactor contacts.** If badly pitted, burned or welded shut, replace with factory supplied contactor. For severe duty conditions such as arctic duty, CCI Thermal recommends the contactor be replaced every two years.
 - Check fuses.** Fuse rating and type are on printed circuit board. Correct fuse must be in the active fuse clip. It is recommended that a spare fuse be stored in the spare fuse clip.
 - Check all explosion-proof conduits.** Replace damaged conduits. All threaded conduit connections must have a minimum 5 turns engagement. Straight threaded conduit must protrude a minimum of 1/16" (1.6 mm) inside enclosures. Taper threaded connections must be at least hand tight.
 - Check electrical resistance on all load side legs.** Reading should be balanced ($\pm 5\%$).

2. MECHANICAL
 - Check for fluid leakage.** The heater core is vacuum charged and contains propylene glycol. Inspect the Pressure Relief Valve label indicator for signs of rupture and degradation. If the paper is torn, disintegrated or otherwise compromised this is an indication that fluid has leaked from the core. If any fluid leakage occurs from the heater, disconnect it from the power supply and have the core replaced. A factory supplied exchange core can be shipped immediately from stock. Refer to the "Repair and Replacement" section for details.
 - Check all enclosures.** Interior of enclosures must be clean, dry and free of foreign materials. Threaded covers must be installed and hand tight.
Note: Enclosure joints are metal to metal. Do not use gasket material or sealant in joints. A grease is applied to the joints at the factory and should be left intact.
 - Check motor shaft bearing play.** Replace motor if play is excessive, or if motor does not run quietly and smoothly. Motor bearings are permanently lubricated.
 - Check fan.** Replace immediately if cracked or damaged.
 - Check louvers.** Louver screws should be tight. Louvers shall not be fully closed or override stops.
 - Check the tightness of all hardware.** All nuts and bolts, including mounting hardware, must be tight.
 - Turn heater on for a minimum of five minutes.** Check for warm air exiting heater through louvers. Crackling or pinging noises within heater during start-up are normal.

IMPORTANT NOTICES

WARNING

Read and adhere to the following. Failure to do so may result in severe or fatal injury.
WARRANTY WILL BE VOID

1. Read and follow all instructions in this manual.
2. Heater is to be used only in atmospheres having an ignition temperature higher than the heater's maximum rated operating temperature as shown on the heater data plate. Refer to applicable electrical codes for additional information.
3. Heater to be used only in the hazardous locations indicated on the heater's data plate.
4. Heater is for dry indoor use only. Do not immerse in water. Do not store or use in areas exposed to rain or snow.
5. Heater is to be connected and serviced only by a qualified electrician experienced with hazardous location equipment.
6. Installation and wiring of the heater must adhere to all applicable codes.
7. Disconnect heater from power supply at fuse box before opening enclosures or servicing heater. Lock the switch in the "OFF" (open) position and/or tag the switch to prevent unexpected power application. Verify that power has been disconnected at fuse box or main panel. Lock the switch in the "OFF" (open) position and/or tag the switch to prevent unexpected power application.
8. This heater is equipped with a single bimetal over temperature high-limit. It is of the automatic reset type and therefore the heater may restart without warning. The heater is not to be operated with the high-limit disabled or disconnected from the control circuit.
9. Venting pressure of the pressure relief valve is factory set. Do not tamper with lock nut.
10. Do not tamper or remove warning label indicator on the PRV.
11. Operate the heater only while it is permanently mounted in an upright position. Refer to the "Installation - Mechanical" section for details.
12. Heater must be kept clean. When operating in a dirty environment, regularly clean the finned tubes, fan, and fan guard. Follow the recommended maintenance procedures. Refer to the "Heater Maintenance Checklist" section for details.
13. The heater core is vacuum charged and contains propylene glycol. **If any fluid leakage occurs from the heater, disconnect it from the power supply and have the core replaced with a factory supplied core. Refer to the "Repair and Replacement" section for details.**
14. Do not operate the heater with any of the louvers fully closed or overriding their stops.
15. Do not operate the heater in atmospheres corrosive to steel or aluminum.
16. Do not operate heater in ambient temperatures above 40°C (104°F).
17. Unused apertures shall be closed with suitable blanking elements. All cable entry devices and blanking elements shall be certified in type of explosion protection flameproof enclosure "d", suitable for the conditions of use and correctly installed.
18. Installer to provide certified Ex "d" sealing fittings and stopping boxes for the same gas groups as the apparatus.
19. The distance from the face of the seal closest to the enclosure (or intended end-use enclosure) and the outside wall of the enclosure (or intended use-enclosure), shall be as small as practical, but in no case more than the size of the conduit or 50 mm, whichever is the lesser.
20. Use factory approved replacement parts only.
21. See applicable electrical codes for seal requirements in field installed conduits. Factory installed conduits require no further sealing.
22. Crackling or pinging noises within the heater core during start up may occur. This is normal.
23. Air discharge near the bottom of the heater may be warmer than the top. This is normal.
24. If there are any questions or concerns regarding the heater, contact the factory. Refer to the last page of this manual for details.
25. Contact original manufacturer for information on the dimensions of the flame proof joints.
26. Heater must be permanently mounted in a level, upright position for operation. See mounting section or mounting instructions label located on the heater's control box.

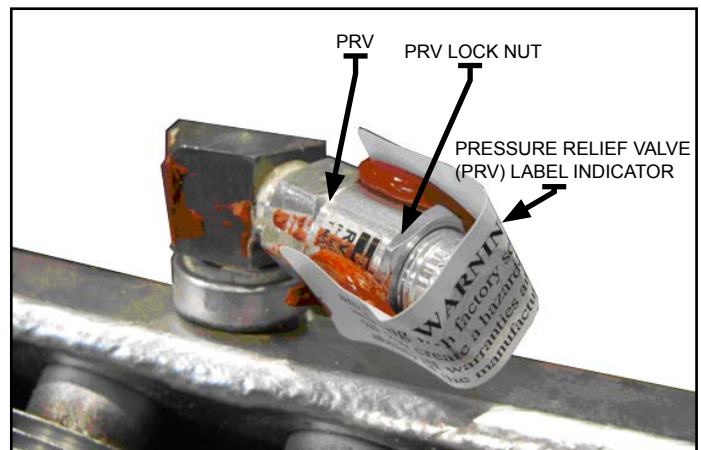

FIGURE 1

TROUBLESHOOTING TIPS

- 1.0 **Heater is not operating**
 - 1.1 Check all fuses in heater control box.
 - 1.2 Check remote disconnect switch and circuit breaker.
 - 1.3 Check voltage supplied to the heater – refer to the heater data plate for voltage requirements.
 - 1.4 Check thermostat by turning it and check continuity with a multimeter.
 - 1.5 Verify that there is a jumper wire present between terminals 5 and 6 on the terminal block located in the control box.
- 2.0 **Contactor is chattering**
 - 2.1 Check supply voltage.
 - 2.2 Check wiring connections. Tighten all loose electrical connections.
 - 2.3 Check thermostat for continuity (See 1.4). If thermostat does not break continuity replace thermostat.
- 3.0 **Contactor is burned or welded**
 - 3.1 Check the contactor for burn marks and blackening. Replace the contactor.
 - 3.2 Check incoming power to the heater to ensure there are no voltage fluctuations.
- 4.0 **Heat exchanger is dirty**
 - 4.1 Clean the heat exchanger using compressed air.
- 5.0 **PRV has released**
 - 5.1 If there are signs that the PRV has released fluid, PRV indicator is broken, blackening around the PRV exit hole, or there are fluid stains visible on the top louver, shut the unit down immediately.
 - 5.2 Check for restricted air flow, bad motor, broken thermostat or malfunctioned high limit.
- 6.0 **Heater is cold on top and warm on bottom**
 - 6.1 The core may have lost its vacuum. Check the PRV for signs of loss of fluid and verify that the PRV label indicator is not broken. If PRV has released, send the unit in for repair or replace the core.
 - 6.2 If the PRV does not indicate loss of fluid, the heater should operate normally. Check for loss of fluid on a weekly basis as a minimum.
 - 6.3 The ambient temperature may be too low. If the ambient temperature is very cold the top of the core will be colder than the bottom – this is normal.
- 7.0 **Unit cycles on high limit – unit turns on and turns off within less than 5 minutes.**
 - 7.1 Check and see if the PRV has released fluid. Core may have lost most or all of its fluid. If PRV has released, send the unit in for repair or replace core.
 - 7.2 The core may be dirty, fan may not be working or may be turning the wrong way (the fan must rotate clockwise as seen from the front of the unit) objects may be stuck in the heat exchanger for drying or warming up – remove any items from the exchanger.
- 8.0 **The Ground Fault Interrupter (GFI) trips on the main panel, or heater blows fuses.**
 - 8.1 Check that you have a fuse of the proper amperage rating.
 - 8.2 Check for loose or frayed wiring.
 - 8.3 If condition is not observable, send heater in for repair.
 - 8.4 Change sensitivity of GFI.
- 9.0 **The fan is turning but very little air comes from the front of the heater.**
 - 9.1 Check fan rotation and ensure that the fan turns clockwise as seen from the front of the heater. Refer to the Installation section below for more information.
 - 9.2 Check motor winding resistance and verify that they are balanced.
 - 9.3 Check fan blade set screws to ensure fan blade is not loose on the motor shaft.

INSTALLATION

The installation instructions provide a general guideline for the installation and wiring of the heater.
All applicable local codes must be adhered to.

MECHANICAL

LOCATION

For optimum heating, the heater should be installed as follows:

1. There are no obstructions that may impede the heater's air inlet or discharge.
2. The air discharge is directed into open areas and not at occupants.
3. The air discharge is not directed at a thermostat.
4. The air discharge is directed across areas of heat loss, such as doors and windows (see Figure 2).
5. The air discharge is directed along and at a slight angle toward exterior walls (see Figure 2).
6. If equipment freeze protection is important, direct air discharge at equipment.
7. Air discharge streams support each other and create a circular air flow. It is not required that the heater's air throw reaches the next heater (see Figure 2).

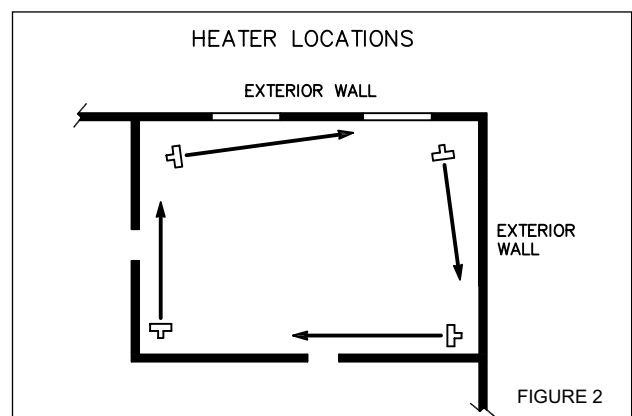

**MAXIMUM TILT ANGLES
(EITHER DIRECTION)**

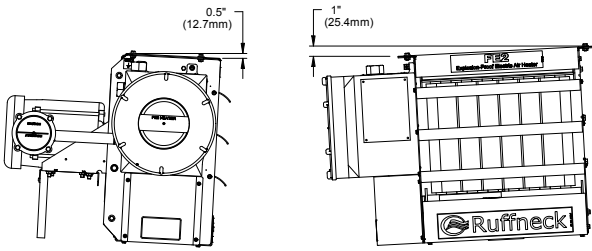

FIGURE 3

**MINIMUM INSTALLATION CLEARANCES
(MUST BE MAINTAINED FOR SERVICE AND AIR FLOW)**

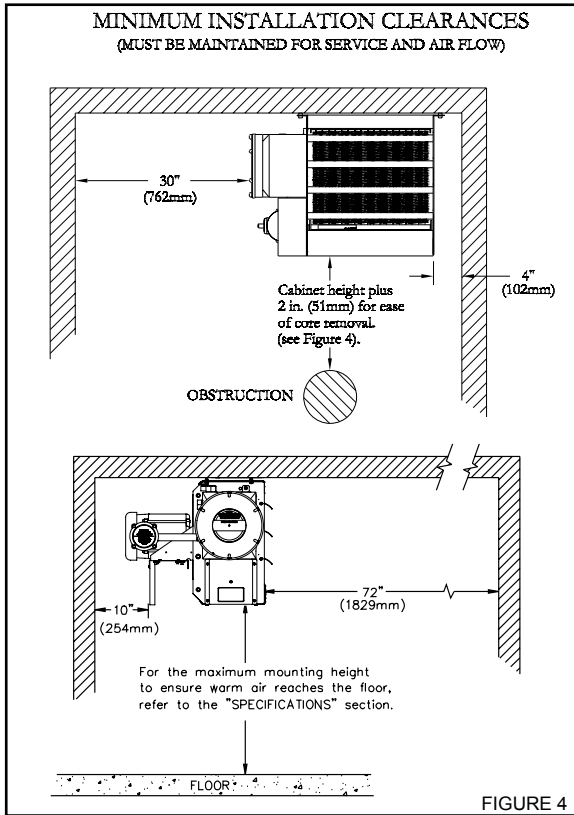

FIGURE 4

MOUNTING

1. The heater must be permanently mounted in a level, upright position for operation. See Figures 3, 4, and 5 for maximum tilt angles, installation clearances, and physical dimensions. For ease of installation, a variety of mounting kits are available from the factory.
2. The mounting structure must be strong enough to:
 - a. support the heater's weight, refer to the "Specifications" section,
 - b. provide sufficient stiffness to prevent excessive vibration, and
 - c. withstand harsh situations such as transportable installations.
3. Do not install conduit below heater (see Figure 4).

DIM	2.5 - 10 kW	12.5 - 20 kW	20.9 - 35 kW	DIM. TOL ±	
A	mm	198	195	196	3
	in	7.75	7.69	7.71	0.13
B	mm	462	566	667	3
	in	18.19	22.31	26.25	0.13
C	mm	686	787	889	4
	in	27	31	35	0.19
D	mm	470	572	674	3
	in	18.50	22.50	26.50	0.13
E	mm	494	596	697	10
	in	19.44	23.44	27.44	0.38
F	mm	444	495	554	8
	in	17.50	19.50	21.81	0.31

DIMENSIONAL TOLERANCES ± 3 mm (0.125") UNLESS OTHERWISE SPECIFIED.

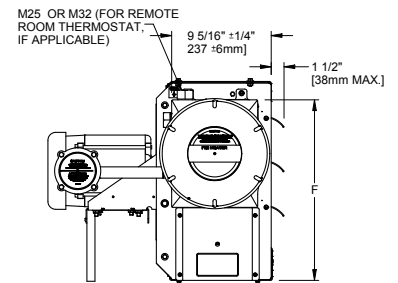
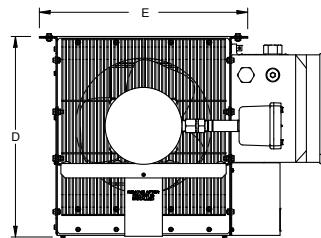
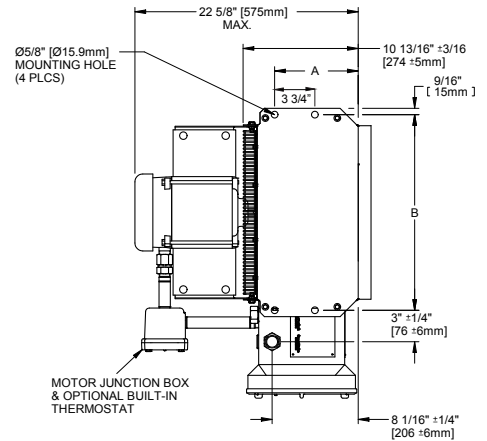

FIGURE 5

ELECTRICAL

WARNING

Disconnect heater from power supply at fuse box before opening enclosures or servicing heater. Lock the switch in the "OFF" (open) position and/or tag the switch to prevent unexpected power application. Verify that power has been disconnected at fuse box or main panel. Lock the switch in the "OFF" (open) position and/or tag the switch to prevent unexpected power application. Installation and wiring of the heater must adhere to all application codes.

GENERAL

1. Use only copper conductors and approved explosion-proof wiring methods during installation. Refer to the "Technical Data" table and heater data plate for conductor rating.
2. External overcurrent protection is required. Refer to the "Technical Data" table and heater data plate for voltage, frequency amperage, and phase. Supply voltage is to be within 10% of the data plate voltage.
3. The heater must be installed by qualified personnel in strict compliance with electrical codes.
4. All heaters come factory prewired and ready for direct connection to the power supply leads.
5. The heater must be individually fused, preferably with Class J time-delay fuses for maximum safety. Unless stated otherwise in your local code, fuse size shall be 125% of line current or next size larger.

FIELD WIRING

1. The supply conductors, ground conductor, and room thermostat conductors all pass through the M32 or M25 opening (see Figure 6) and are to be wired into the control enclosure (see Figure 7A).
2. Heater may be supplied with a factory installed built-in room thermostat (see Figure 8). On heaters not supplied with this option, it is recommended that a remote room thermostat be used. Connect the remote room thermostat conductors to the printed circuit board terminal block "TSTAT". Any thermostat used with this heater must:
 - a. be of an explosion-proof type,
 - b. be rated 125V minimum,
 - c. have a minimum 2 amp capacity, and
 - d. open on temperature rise.

3. The internal grounding terminal in the control enclosure shall be used as the equipment grounding means. An external bonding terminal (see Figure 6) is provided for a supplementary bonding connection where local authorities permit or require such a connection.

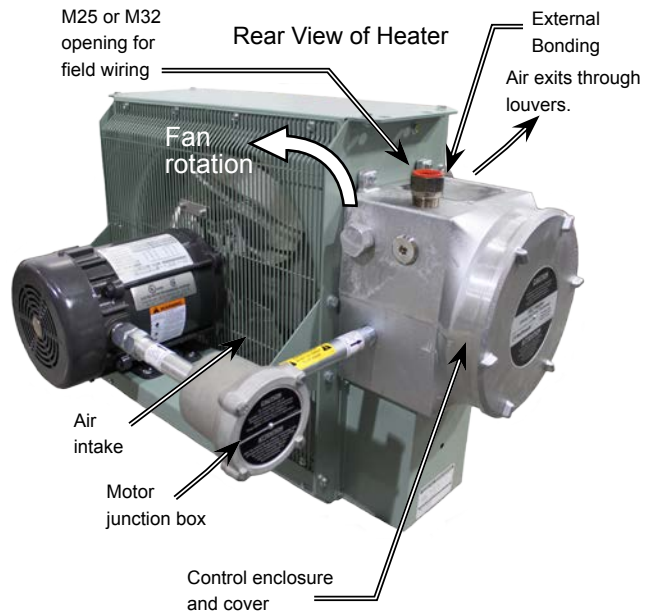

FIGURE 6

FINAL INSPECTION

1. Before application of electrical power:
 - a. Check that all connections are secured and comply with the applicable wiring diagram (see Figure 9) and code requirements,
 - b. Confirm that the power supply is compatible with the data plate rating of the heater,
 - c. Remove any foreign objects from the heater,
 - d. Install all covers and verify that all enclosures are well secured, and
 - e. Ensure that the fan rotates freely. See Figure 6 for proper direction of fan rotation.

Control Enclosure & Field Wiring

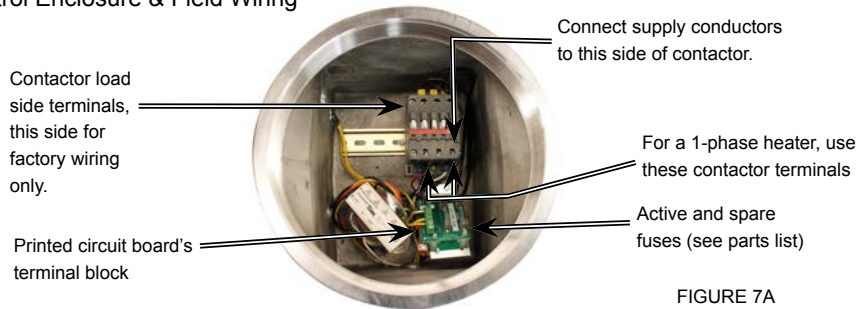

FIGURE 7A

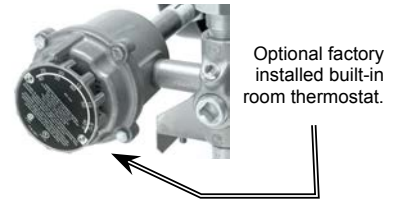
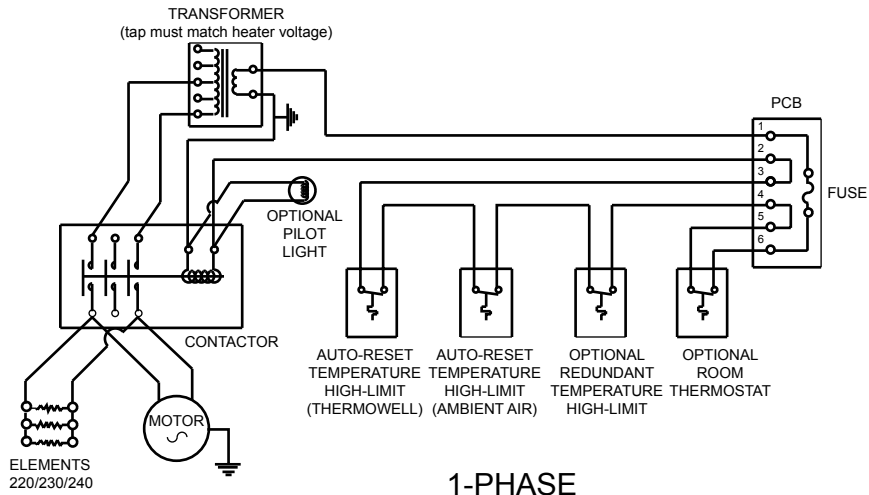

FIGURE 8



FIGURE 7B



1-PHASE
WIRING SCHEMATIC

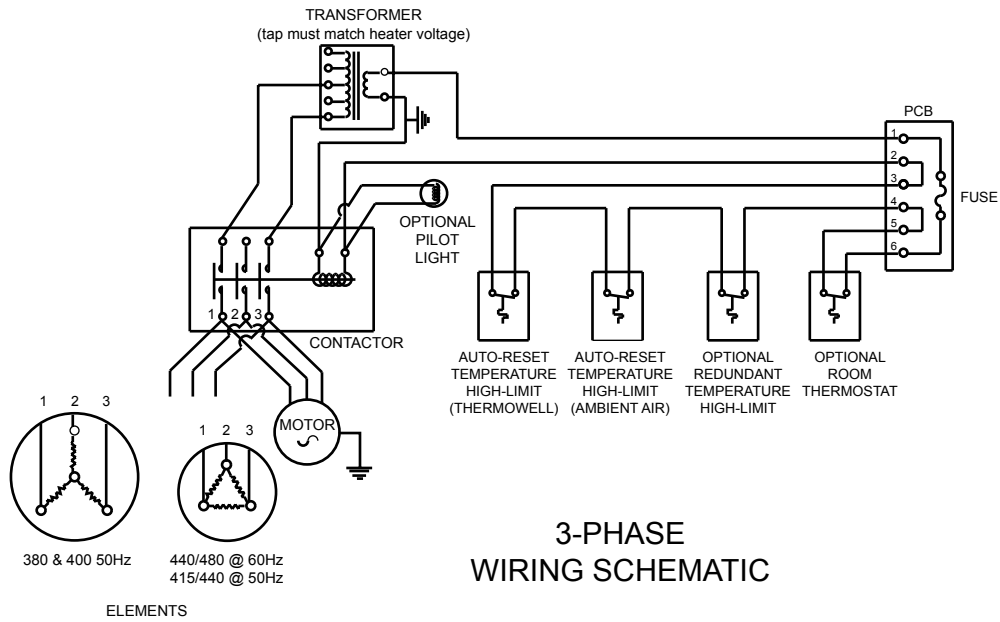

3-PHASE
WIRING SCHEMATIC

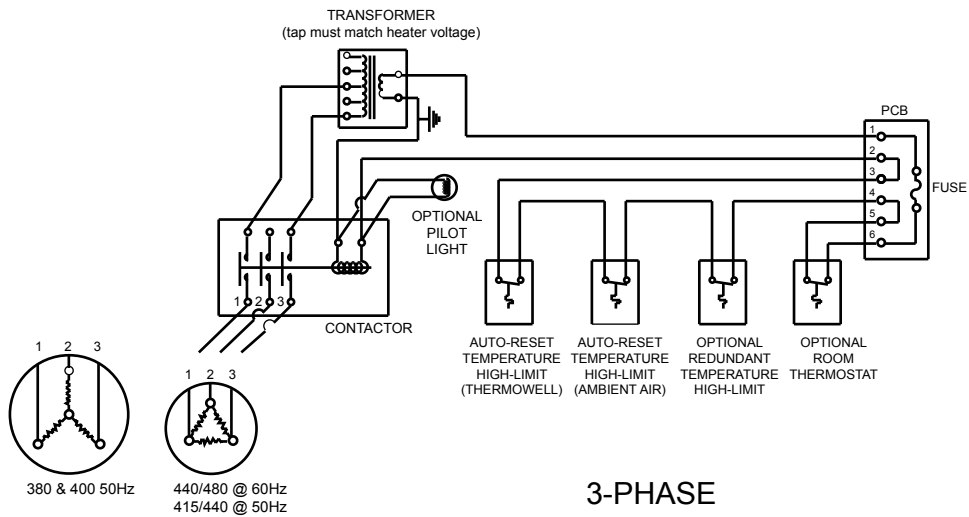

3-PHASE
WIRING SCHEMATIC
CONTINUOUS FAN OPTION

FE2 TECHNICAL DATA FOR 50 HZ ELECTRIC AIR HEATERS

Model	Voltage	Nominal Wattage	Heater Wattage	Phase	Max. Motor Nameplate Current (A)	Total Current	Minimum Circuit Ampacity	Supply Wire	Maximum Fuse Size	Temperature Rise		Core Kit Part Number	Contactor Part Number
	(V)	(kW)	(W)			(A)	(A)	(AWG)	(A)	°C	°F		
FE2-220150-025	220	2.5	2270	1	2.5	11.4	14.3	14	15	10.0	18.0	12122	10557
FE2-220150-042	220	4.2	3950	1	2.5	19.1	23.9	10	25	17.4	31.3	12123	10557
FE2-220150-063	220	6.3	6050	1	2.5	28.6	35.8	8	40	15.2	27.4	12124	10557
FE2-220150-084	220	8.4	8140	1	2.5	38.2	47.8	6	50	20.5	36.8	12125	10557
FE2-220150-126	220	12.6	12100	1	2.5	57.3	71.6	4	75	14.7	26.4	12126	10558
FE2-230150-028	230	2.8	2480	1	2.5	12.2	15.3	12	20	10.9	19.6	12122	10557
FE2-230150-046	230	4.6	4320	1	2.5	20.0	25.0	10	25	19.0	34.2	12123	10557
FE2-230150-069	230	6.9	6610	1	2.5	30.0	37.5	8	40	16.6	29.9	12124	10557
FE2-230150-138	230	13.8	13230	1	2.5	59.9	74.9	2	80	16.1	28.9	12126	10558
FE2-240150-030	240	3.0	2700	1	2.5	12.5	15.6	12	20	11.9	21.4	12122	10557
FE2-240150-050	240	5.0	4701	1	2.5	20.8	26.0	10	30	20.7	37.2	12123	10557
FE2-240150-075	240	7.5	7200	1	2.5	31.3	39.1	8	40	18.1	32.6	12124	10557
FE2-240150-150	240	15.0	14400	1	2.5	62.5	78.1	2	80	17.5	31.4	12126	10558
FE2-380350-025	380	2.5	2260	3	1.1	3.8	4.8	16	5	10.0	17.9	12122	10557
FE2-380350-042	380	4.2	3930	3	1.1	6.4	8.0	16	10	17.3	31.1	12123	10557
FE2-380350-063	380	6.3	6020	3	1.1	9.6	12.0	14	15	15.1	27.2	12124	10557
FE2-380150-084	380	8.4	8100	3	1.1	12.8	16.0	12	20	20.4	36.6	12125	10557
FE2-380350-125	380	12.5	12030	3	1.1	19.0	23.8	10	25	14.6	26.3	12126	10557
FE2-380350-167	380	16.7	16220	3	1.1	25.4	31.8	8	35	19.7	35.4	12127	10557
FE2-380350-209	380	20.9	20230	3	1.1	31.8	39.8	8	40	11.9	21.4	12128	10557
FE2-400350-028	400	2.8	2500	3	1.1	4.0	5.0	16	5	11.0	19.8	12122	10557
FE2-400350-046	400	4.6	4350	3	1.1	6.6	8.3	16	10	19.2	34.5	12123	10557
FE2-400350-069	400	6.9	6670	3	1.1	10.0	12.5	14	15	16.8	30.2	12124	10557
FE2-400350-093	400	9.3	89770	3	1.1	13.4	16.8	12	20	22.6	40.6	12125	10557
FE2-400350-139	400	13.9	13330	3	1.1	20.1	25.1	10	30	16.2	29.1	12126	10557
FE2-400350-185	400	18.5	17970	3	1.1	26.7	33.4	8	35	21.8	39.2	12127	10557
FE2-400350-231	400	23.1	22420	3	1.1	33.3	41.6	8	45	13.1	23.7	12128	10557
FE2-415350-037	415	3.7	3510	3	1.1	5.1	6.4	16	10	16.3	27.8	12130	10557
FE2-415350-075	415	7.5	7240	3	1.1	10.4	13.0	14	15	18.9	32.7	12132	10557
FE2-415350-149	415	14.9	14510	3	1.1	20.9	25.9	10	30	18.1	31.7	12134	10557
FE2-415350-224	415	22.4	21820	3	1.1	31.2	39.0	8	40	13.1	23.0	12136	10557
FE2-440350-042	440	4.2	3950	3	1.1	5.5	6.9	16	10	17.4	31.3	12130	10557
FE2-440350-084	440	8.4	2740	3	1.1	11.0	13.8	14	15	20.5	36.8	12132	10557
FE2-440350-168	440	16.8	16310	3	1.1	22.0	27.5	8	35	19.8	35.6	12134	10557
FE2-440350-210	440	21.0	20340	3	1.1	27.6	34.4	8	35	11.9	21.5	12135	10557

NOTES:

1. Minimum conductor size for 30°C (86°F) ambient. Derate conductor for ambient temperature. Use minimum 90°C (194°F) insulation.
2. Heater is functioning normally if at rated voltage the amp draw is within 10% of the value in this table.
3. Operation at lower voltages will result in reduced heat output and amp draw.
4. Add "T" to model number when adding a built-in thermostat.
5. Add "U" to model number for units with continuous fan option.
6. Add "A" to model number for units with stainless steel cabinet.

FE2 TECHNICAL DATA FOR 60 HZ ELECTRIC AIR HEATERS

Model	Voltage	Nominal Wattage	Heater Wattage	Phase	Max. Motor Nameplate Current (A)	Total Current	Minimum Circuit Ampacity	Supply Wire	Maximum Fuse Size	Temperature Rise		Core Kit Part Number	Contactor Part Number
	(V)	(kW)	(W)			(A)	(A)	(AWG)	(A)	°C	°F		
FE2-220160-025	220	2.5	2270	1	2.2	11.4	14.3	14	15	8.0	14.4	12122	10557
FE2-220160-042	220	4.2	3950	1	2.2	19.1	23.9	10	25	13.9	25.0	12123	10557
FE2-220160-063	220	6.3	6050	1	2.2	28.6	35.8	8	40	12.5	22.5	12124	10557
FE2-220160-084	220	8.4	8140	1	2.2	38.2	47.8	6	50	16.9	30.3	12125	10557
FE2-220160-126	220	12.6	12100	1	2.2	57.3	71.6	2	75	12.2	21.9	12126	10558
FE2-230160-028	230	2.8	2480	1	2.2	12.2	15.3	12	20	8.7	15.7	12122	10557
FE2-230160-046	230	4.6	4317	1	2.2	20.0	25.0	10	25	15.2	27.3	12123	10557
FE2-230160-069	230	6.9	6613	1	2.2	30.0	37.5	8	40	13.7	24.6	12124	10557
FE2-230160-138	230	13.8	13225	1	2.2	59.9	74.9	2	80	13.3	23.9	12126	10558
FE2-240160-030	240	3.0	2700	1	2.2	12.5	15.6	12	20	9.5	17.1	12122	10557
FE2-240160-050	240	5.0	4701	1	2.2	20.8	26.0	10	30	16.5	29.8	12123	10557
FE2-240160-075	240	7.5	7200	1	2.2	31.3	39.1	8	40	14.9	26.8	12124	10557
FE2-240160-100	240	10.0	9690	1	2.2	41.7	52.1	6	60	20.1	36.1	12125	10558
FE2-240160-150	240	15.0	14400	1	2.2	62.5	78.1	2	80	14.5	26.1	12126	10558
FE2-440360-042	440	4.2	3950	3	1.0	5.5	6.9	16	10	13.9	25.0	12130	10557
FE2-440360-084	440	8.4	8142	3	1.0	11.0	13.8	14	15	16.9	30.3	12132	10557
FE2-440360-168	440	16.8	16310	3	1.0	22.0	27.6	8	35	16.4	29.5	12134	10557
FE2-440360-210	440	21.0	20343	3	1.0	27.5	34.4	8	35	9.9	17.9	12135	10557
FE2-480360-030	480	3.0	2700	3	1.0	3.6	4.5	14	15	9.5	17.1	12129	10557
FE2-480360-050	480	5.0	4701	3	1.0	6.0	7.5	14	15	16.5	29.8	12130	10557
FE2-480360-075	480	7.5	7200	3	1.0	9.0	11.3	14	15	14.9	26.8	12131	10557
FE2-480360-100	480	10.0	9690	3	1.0	12.0	15.0	14	15	20.1	36.1	12132	10557
FE2-480360-150	480	15.0	14400	3	1.0	18.0	22.5	10	25	14.5	26.1	12133	10557
FE2-480360-200	480	20.0	19410	3	1.0	24.1	30.1	8	35	19.5	35.1	12134	10557

NOTES:

1. Minimum conductor size for 30°C (86°F) ambient. Derate conductor for ambient temperature. Use minimum 90°C (194°F) insulation.
2. Heater is functioning normally if at rated voltage the amp draw is within 10% of the value in this table.
3. Operation at lower voltages will result in reduced heat output and amp draw.
4. Add "T" to model number when adding a built-in thermostat.
5. Add "U" to model number for units with continuous fan option.
6. Add "A" to model number for units with stainless steel cabinet.

PARTS LIST
FORCED AIR ELECTRIC HEATERS

FE2 PART NUMBERS					
ITEM	2.5 - 4.6 kW	6.3 - 10 kW	12.5 - 20 kW	20.9 - 35 kW	Description
1	**				Core
2	Painted: 9203 S.S.: 9507		Painted: 9204 S.S.: 9508	Painted: 9205 S.S.: 9509	Panel, Bottom
3	Painted: 9191 S.S.: 9192		Painted: 9193 S.S.: 9194	Painted: 9195 S.S.: 9196	Panel, Left Side
4	4075		4076	4077	Louver Kit, c/w Screws
5	Painted: 9200 S.S.: 9513		Painted: 9201 S.S.: 9514	Painted: 9202 S.S.: 9515	Panel, Top
6	Painted: 9197 S.S.: 9510		Painted: 9198 S.S.: 9511	Painted: 9199 S.S.: 9512	Panel, Right
7	Painted: 3782 S.S.: 9212		Painted: 3783 S.S.: 9213	Painted: 3784 S.S.: 9214	Panel, Fan Shroud
8	4022	4023	4024	4025	Fan Blade
9	Painted: 4078 S.S.: 9504		Painted: 4079 S.S.: 9505	Painted: 4080 S.S.: 9506	Fan Guard Kit
10	1377				220/230/240V 1PH 50HZ 220/230/240V 1PH 60HZ
	1699				380/400/415/440V 3PH 50HZ 440/480V 3PH 60HZ
11	Painted: 3789 S.S.: 9112				Bracket, Motor Mount Right
12	Painted: 3785 S.S.: 9206		Painted: 3786 S.S.: 9207	Painted: 3787 S.S.: 9208	Channel, Motor Mount
13	Painted: 3788 S.S.: 9111				Bracket, Motor Mount Left
14	3737				Coupling, Motor
15	9500		3813	10389	Conduit, Motor
16	5371				Cover, Thermostat Enclosure
17	3813				Conduit, Control Enclosure
18	9314		9315	9316	Conduit, Element Enclosure
19	9679				Enclosure, Element
20	3510				Cover, Element Enclosure
21	Painted: 9354 S.S.: 9516		Painted: 9355 S.S.: 9517	Painted: 9356 S.S.: 9518	Panel, Element Enclosure Guard
22	12225				Enclosure, Thermostat, Metric
23	5032				Thermostat, Built-in-kit
24	-		-	-	Enclosure, Control
25	**		**	**	Contactors
26	10556 (60HZ)		11295 (50HZ)		Transformer
27	3809				Bracket, Printed Circuit Board
28	1876				Terminal, 6-14 Ga. Screw Lug
29	9357				Fuse, Buss MDQ - 1/2 Amp
30	3514				Assembly, Printed Circuit Board
31	9158				Cover, Control Enclosure
32	9267				Thermowell, Ambient High-Limit
33	-				High Limit, Ambient Temperature
34	9289				Plug, 1" NPT Explosion Proof
35	-				Temperature High-Limit Kit
36	Provided with Core Kits**				Bus-Bar, Straight
37					Bus-Bar, Small Curved
38					Bus-Bar, Large Curved
39	7401				Terminal, 6-14 Ga Lug, 1/4 Mtg Hole
40	8646				Adapter, 1" NPT to M32
41	8644				Adapter, 1" NPT to M25

** See technical data table for part numbers. NOTE: For items not shown, contact factory.

HEATER ASSEMBLY DIAGRAM

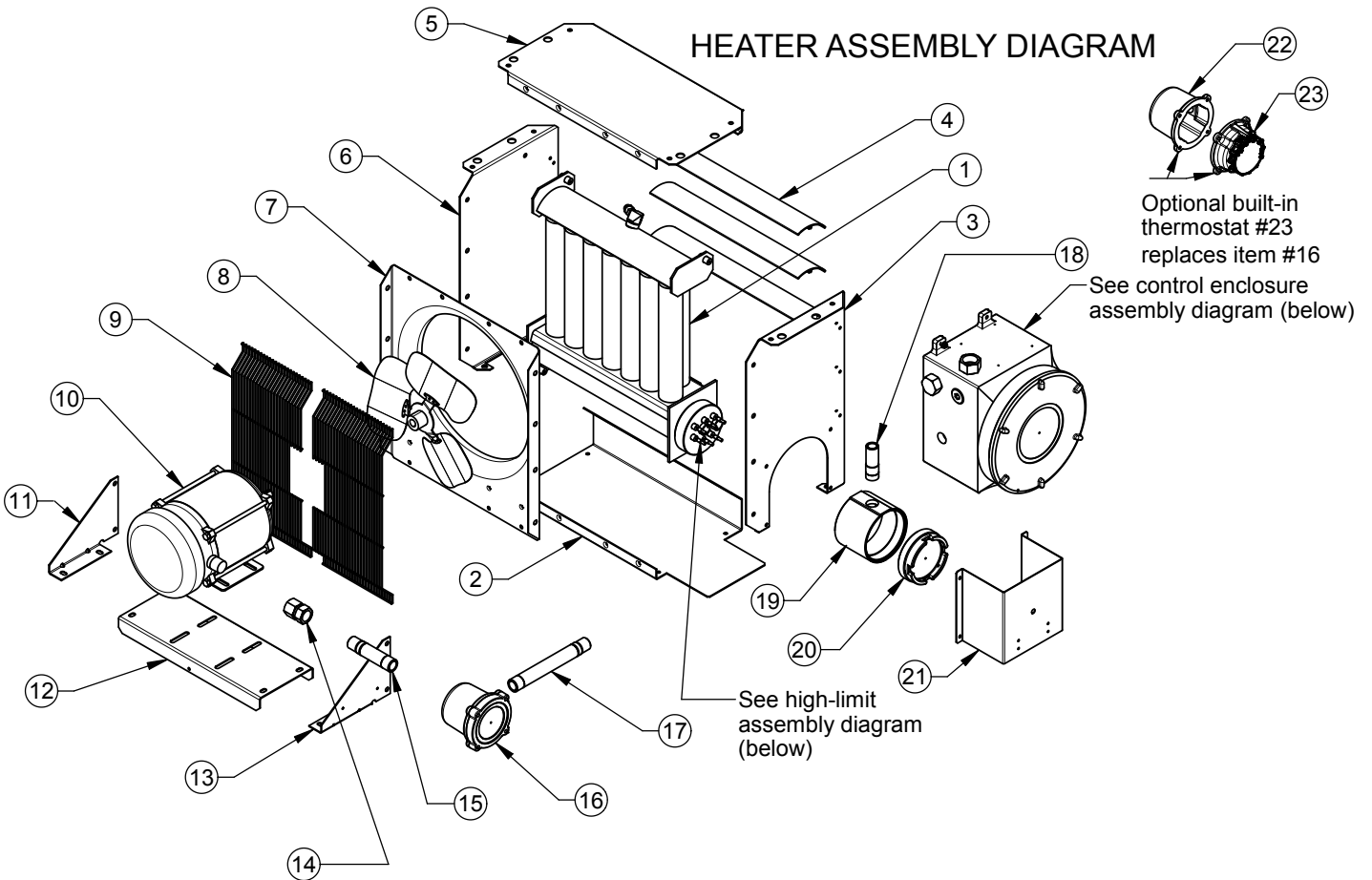

CONTROL ENCLOSURE ASSEMBLY DIAGRAM

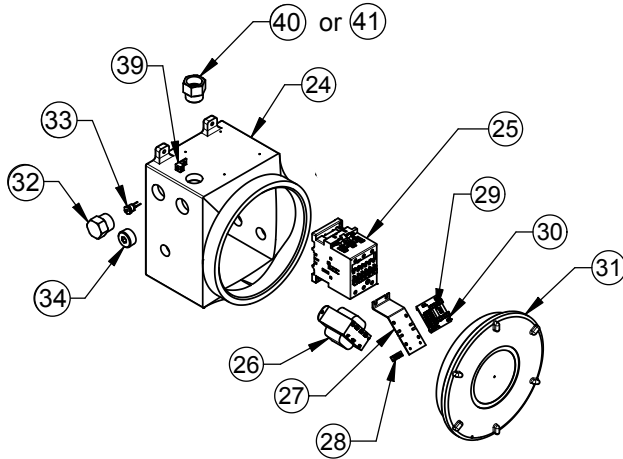

HIGH LIMIT ASSEMBLY DIAGRAM

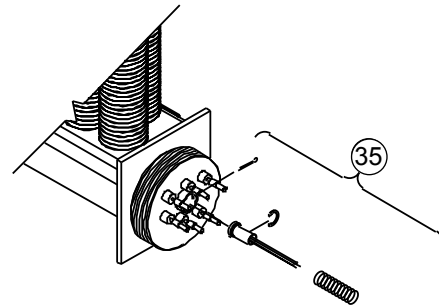

BUS-BAR CONFIGURATION ALL 1-PHASE MODELS

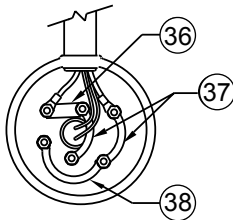

BUS-BAR CONFIGURATION ALL 3-PHASE (EXCEPT 380V & 400V 50 HERTZ)

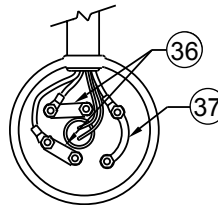

BUS-BAR CONFIGURATION 3-PHASE 380V & 400V 50 HERTZ MODELS ONLY

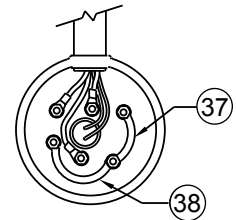

SPECIFICATIONS FOR ALL 50 HZ MODEL

Nominal kW		2.5 to 3.0	3.7 to 5.0	6.3 to 7.5	8.4 to 10	12.5 to 13.9	14.9 to 20	20.9 to 21	22.4 to 23.1
Max. Altitude	(m) (ft.)	3,658 12,000	2,438 8,000	3,048 10,000	2,134 7,000	3,048 10,000	2,134 7,000	3,048 10,000	2,134 7,000
Air Flow	@ 21°C (m ³ /hr) @ 70°F (CFM)	679 400		1189 700		2463 1450		5096 3000	
Horizontal Air Throw	(m) (ft)	4.0 13		7.6 25		10.7 35		18.2 60	
Max. Mounting Height	(m) (to underside) (ft)	2.1 7		3.0 10		3.0 10		6.1 20	
Motor Power	(hp) (min) (kW)	1/4 0.373		1/2 0.373		1/2 0.373		1/2 0.373	
Motor Speed	(RPM)	1425		1425		1425		1425	
Fan Diameter	(mm) (in)	305 12		406 16		508 20			
Net Weight	(kg) (lbs)	68.9 140		81.6 168		91.2 201			
Shipping Weight	(kg) (lbs)	88.0 194		98.9 218		114.3 252			
Temperature Code Rating		T3 (200°C / 392°F)							
Enclosures		NEMA Type 7 & 9. For dry, indoor use only. Do not immerse in water. Do not store or use in areas exposed to rain or snow.							
Motor Type		Explosion-proof. Thermally protected. Permanently lubricated ball bearings. 1425 RPM							
Fan		Aluminum blade. Steel spider and hub with 5/8" (15.875 mm) bore.							
Fan Guard		Split design with close wire spacing. 1/4" (6.3 mm) dia. probe will not enter.							
Mounting Holes		Four 5/8" (15.9 mm) diameter holes at top of heater.							
Heating Elements		Three long-life, low watt-density, high grade metal-sheathed elements.							
Temperature High-Limit		Automatic reset type, snap-action bimetal, open on temperature rise. Rated 100,000 cycles at 10 amps, handles 0.128 amps.							
Control Circuit		120V, 0.128 amps, 15VA. (Grounded)							
Optional Built-in Thermostat		Explosion-proof. 2°C to 28°C (36°F to 82°F)							
Control Transformer		Multi-tap primary, 120V secondary, 50VA.							
Contactors		60 or 80 amp. Rated for 1,000,000 mechanical operations. 120V, 15VA coil (separately fuse-protected).							
Heat Transfer Fluid		Long-life formulated propylene glycol and water							
Cabinet Material		14 gauge (1.90 mm) (0.075") steel. Epoxy coated with five-stage pretreatment, including iron phosphate. Optional stainless steel.							
Core		Steel with integral aluminum fins, vacuum charged and hermetically sealed.							
Conduit Material		Heavy walled, 0.122" (3.1 mm) steel.							
Overpressure Protection		Preset 100 psig (690 kPa) pressure relief valve, aluminum body, no field serviceable parts.							
Operational Temperature Limitations		-20°C to 40°C (-4°F to 104°F)							
Storage Limitations		-45°C to 80°C (-49°F to 176°F), short term to 120°C (248°F). Do not immerse in water. Do not exposed to rain or snow.							

SPECIFICATIONS FOR ALL 60 HZ MODEL

Nominal kW		2.5 to 3.0	3.7 to 5.0	6.3 to 7.5	8.4 to 10	12.5 to 13.9	14.9 to 20	20.9 to 21	22.4 to 23.1
Max. Altitude	(m)	3,658	2,438	3,048	2,134	3,048	2,134	3,048	2,134
	(ft.)	12,000	8,000	10,000	7,000	10,000	7,000	10,000	7,000
Air Flow	@ 21°C (m ³ /hr)	850		1444		2973		6116	
	@ 70°F (CFM)	500		850		1750		3600	
Horizontal Air Throw	(m)	4.6		9.1		12.2		21.3	
	(ft)	15		30		40		70	
Max. Mounting Height (to underside)	m)	2.1		3.0		3.0		6.1	
	(ft)	7		10		10		20	
Motor Power	(hp)	1/4			1/2		1/2		
	(min) (kW)	0.373			0.373		0.373		
Motor Speed	(RPM)	1725			1725		1725		
Fan Diameter	(mm)	305			406		508		
	(in)	12			16		20		
Net Weight	(kg)	63.5			76		91		
	(lbs)	140			168		201		
Shipping Weight	(kg)	88			99		114		
	(lbs)	194			218		252		
Temperature Code Rating		T3 (200°C / 392°F)							
Enclosures		NEMA Type 7 & 9. For dry, indoor use only. Do not immerse in water. Do not store or use in areas exposed to rain or snow.							
Motor Type		Explosion-proof. Thermally protected. Permanently lubricated ball bearings. 1725 RPM							
Fan		Aluminum blade. Steel spider and hub with 5/8 in. (15.875 mm) bore.							
Fan Guard		Split design with close wire spacing. 1/4in. (6.3 mm) dia. Probe will not enter.							
Mounting Holes		Four 5/8 in. (15.9 mm) diameter holes at top of heater.							
Heating Elements		Three long-life, low watt-density, high grade metal-sheathed elements.							
Temperature High-Limit		Automatic reset type, snap-action bimetal, open on temperature rise. Rated 100,000 cycles at 10 amps, handles 0.130 amps.							
Control Circuit		115 Volts, 0.130 amps, 15 VA. (Grounded)							
Optional Built-in Thermostat		Explosion-proof. 2°C to 28°C (36°F to 82°F)							
Control Transformer		Multi-tap primary, 115 V secondary, 50 VA.							
Contactors		60 or 80 amp. Rated for 1,000,000 mechanical operations. 120 Volts, 15 VA coil (separately fuse - protected).							
Heat Transfer Fluid		Long life formulated ethylene glycol and water							
Cabinet Material		14 ga. (1.90 mm) (0.075in.) steel. Epoxy coated with five-stage pretreatment, including iron phosphate.							
Core		Steel with integral aluminum fins, vacuum charged and hermetically sealed.							
Conduit Material		Heavy walled, 0.122 in. (3.1 mm) steel.							
Overpressure Protection		Preset 100 psig (690 kPa) seep pressure relief valve, aluminum body, no field serviceable parts.							
Operational Temperature Limitations		-20°C to 40°C (-4°F to 104°F)							
Storage Limitations		-45°C to 80°C (-49°F to 176°F), short term to 120°C (248°F). Do not immerse in water. Do not store or use in areas exposed to rain or snow.							

REPAIR & REPLACEMENT

WARNING

Disconnect heater from power supply at fuse box before opening enclosures or servicing heater. Lock the switch in the "OFF" (open) position and/or tag the switch to prevent unexpected power application.

Verify that power has been disconnected at fuse box or main panel. Lock the switch in the "OFF" (open) position and/or tag the switch to prevent unexpected power application. Heater surfaces may be hot.

1. After repairing any component:
 - a. check that electrical connections are correct and secure (see Figure 9),
 - b. remove any foreign material from enclosures,
 - c. install and secure all covers,
 - d. ensure that all fasteners are tight,
 - e. remove all foreign objects from heater, and
 - f. ensure air exits through louvers and fan rotates counterclockwise when viewed from rear of heater (see Figure 14).

CORE

The heater core is vacuum charged and not field repairable.

For core removal:

1. Remove cabinet bottom and element enclosure cover.
2. Disconnect all wires entering element enclosure (see Figure 10).
3. Slightly loosen all cabinet bolts shown in Figure 10, to prevent the core from binding.
4. With an assistant supporting the weight of the core, remove the 3 core mounting bolts. Carefully lower the core out of the cabinet (see Figure 11).
5. To return core to factory, use crate supplied with exchange core to protect the element terminals and plate threads.
6. To reinstall, lift the core up into cabinet while an assistant guides the element wires into the element enclosure conduit.
7. Position the core and tighten the 3 core mounting bolts. Tighten the remaining cabinet bolts.

TEMPERATURE HIGH-LIMIT

1. Remove temperature high-limit assembly and clean the inside of the thermowell (see Figure 12). A clean thermowell will ensure good thermal contact.
2. Use only a factory supplied temperature high-limit to ensure safe operation.
3. Apply a small drop, 3/32" (2mm) diameter, of heat sink compound to the center of the metal cap but do not spread. This is critical for proper thermal contact between the temperature high-limit and the thermowell (see Figure 12).
4. Reinstall the temperature high-limit assembly with the snap ring and spring into the thermowell without damaging the insulating tube. Secure in place with the cotter pin (see Figure 13).

MOTOR, FAN & FAN GUARD

1. Remove bolts holding the motor to the motor mount. On units with a built in thermostat, remove the bolts on the back of the thermostat enclosure.
2. Remove conduit #1 located between motor junction box and control enclosure by turning it in the direction illustrated (see Figure 14). Note conduits #1 and #2 are not interchangeable and have left hand threads on one end, this end is indicated by a machined groove.
3. Remove the 2 piece fan guard assembly (see Figure 15).
4. Lift the motor assembly off the motor mount.
5. Before removing the fan, measure and record the location of the fan hub on the motor shaft (see Figure 16). If difficult to remove, use a gear puller on the fan hub.
6. To reassemble, place motor assembly onto motor mount and fasten the fan guard to cabinet.
7. Simultaneously engage and tighten both ends of conduit #1 into enclosures. Leave a 1/16" to 3/16" (1.6 to 4.8 mm) gap between the motor and fan guard (see Figure 16). Adjust conduit #2 to center the fan in the shroud.
8. To ensure a minimum 5 thread engagement, threaded ends of conduits must protrude a minimum of 1/16" (1.6 mm) into enclosures. The groove on conduit #2 must not be more than 7/8" (22 mm) from motor coupling (see Figure 14).
9. Bolt motor to motor mount. Manually spin the fan blade to ensure fan rotates freely.
10. Air must exit through louvers and fan must rotate counterclockwise when viewed from rear of heater (see Figure 14).

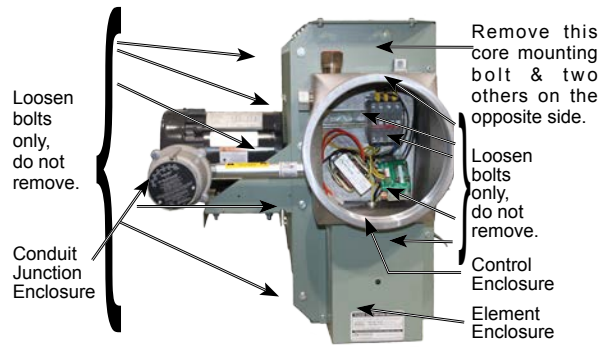

FIGURE 10



FIGURE 11



FIGURE 12



FIGURE 13

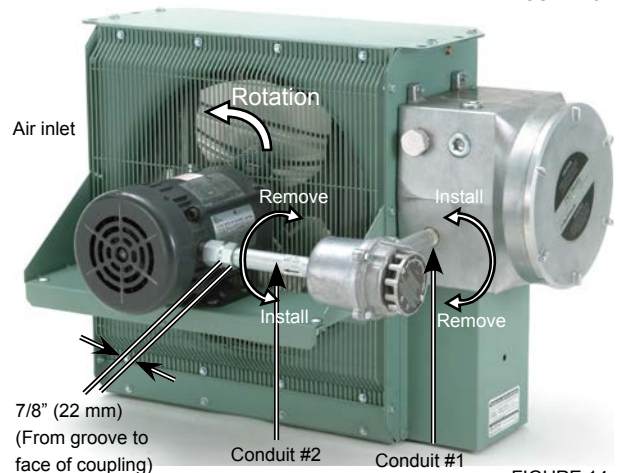

FIGURE 14



FIGURE 15



FIGURE 16

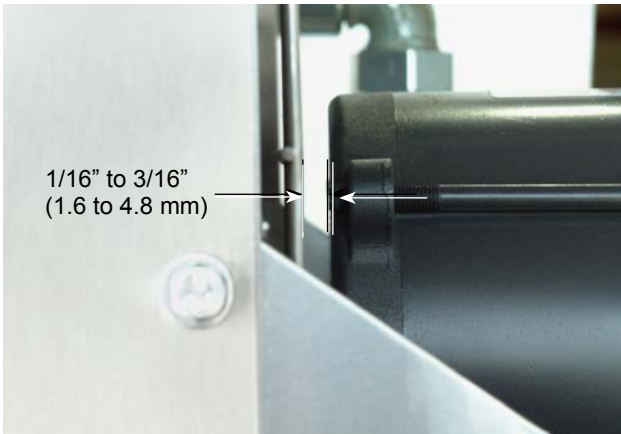

1/16" to 3/16"
(1.6 to 4.8 mm)

FIGURE 17

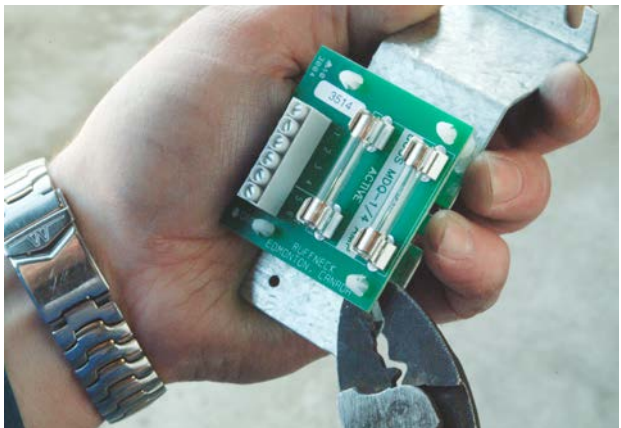

FIGURE 18

PRINTED CIRCUIT BOARD

1. After removing the printed circuit board (P.C. Board) bracket assembly from the control enclosure, separate the P.C. Board from the bracket by cutting off the plastic spacers (see Figure 18).
2. Reinstall a new factory supplied P.C. Board onto the mounting bracket using new non-conducting spacers of the same length. Spacers are supplied with a new P.C. Board. Reinstall the control circuit ground wire to the printed circuit board bracket (see Figure 9).

INDUSTRIAL CONTACTOR

1. Replace with a factory supplied contactor of the same rating.

TRANSFORMER

1. Replace with a factory supplied transformer of the same rating.
2. On the new transformer, select primary wires to match heater voltage. Ensure that the correct transformer secondary lead is grounded (see Figure 9). Individually terminate all unused wires using closed end connectors.

FUSE

1. Replace fuse with one of the same type and rating as indicated on P.C. Board or refer to parts list. An extra fuse should be stored in the clips marked "SPARE".

HEATING ELEMENTS

1. Heating elements are an integral part of the vacuum charged core. A factory exchange core can be shipped immediately from stock. Refer to "Core" section for details.

CABINET PANELS

1. Bolt-on cabinet panels are individually replaceable.

THERMOSTAT COVER SCREWS

1. Replace thermostat cover bolts with four plated steel hex head bolts, M6 x 20mm long property class 9.8, 720MPa minimum yield strength.



NOTES

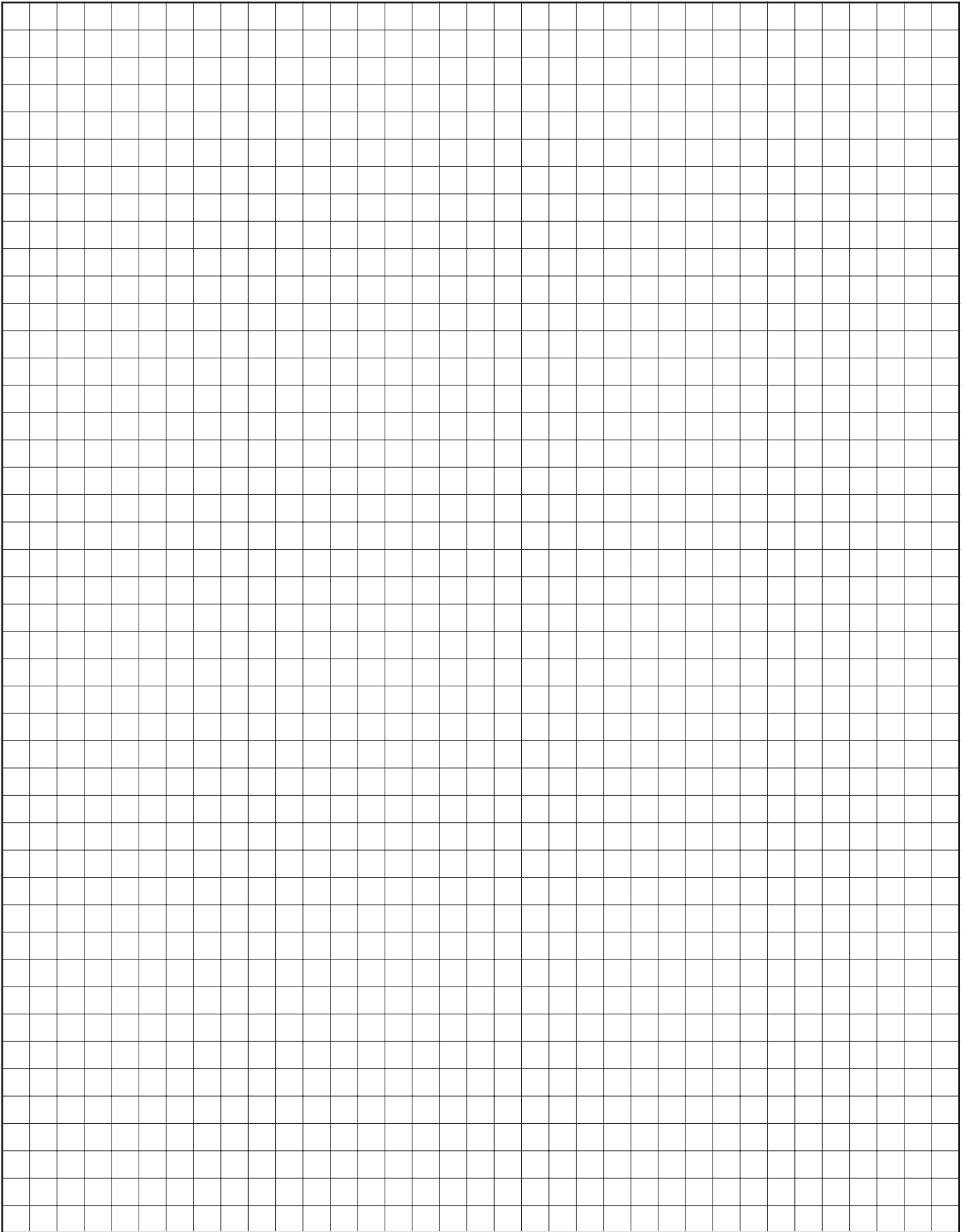

NOTES

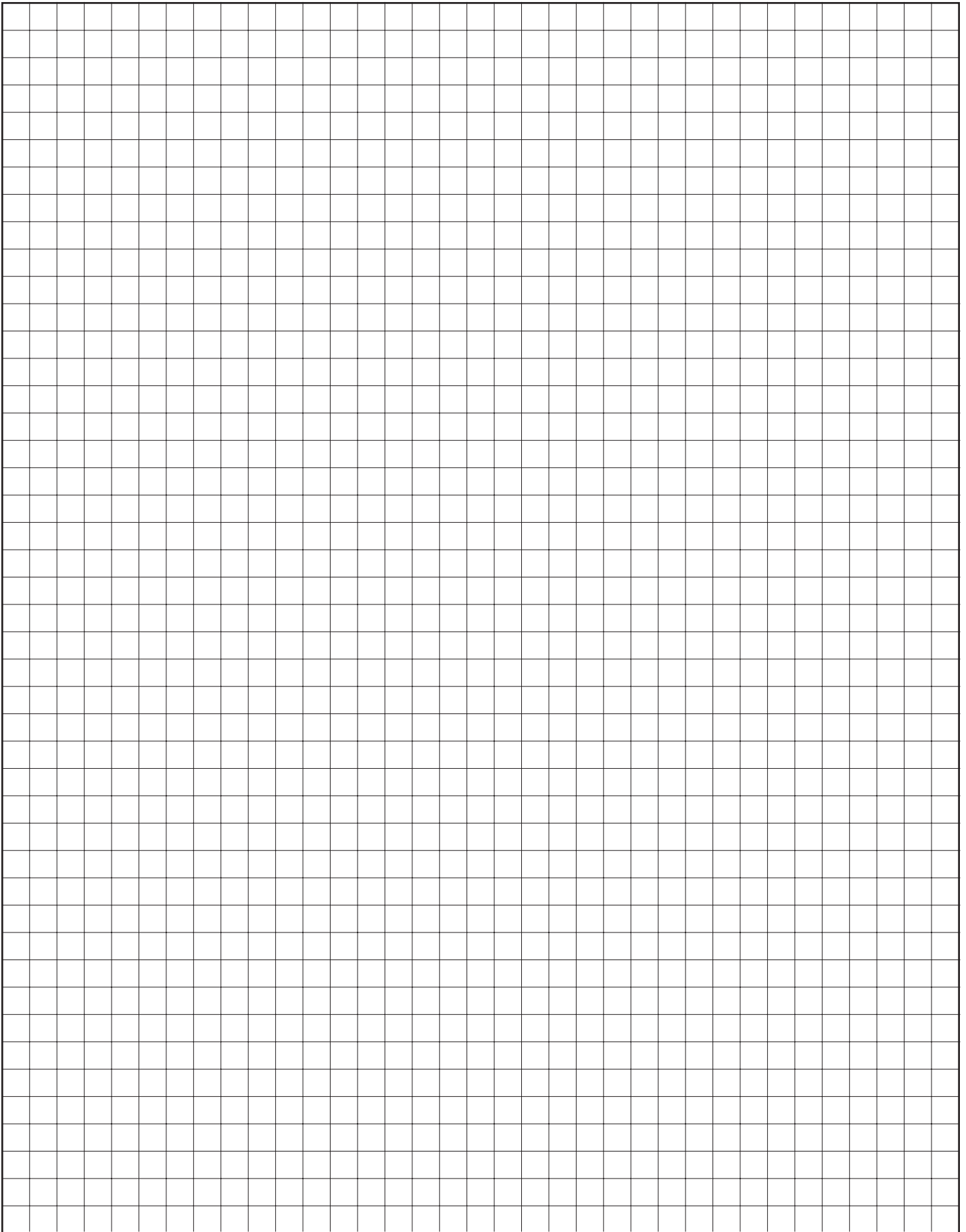



Heaters for the Harshest Environments
5918 Roper Road, Edmonton, Alberta, Canada T6B 3E1
Phone: (780) 466-3178 Fax: (780) 468-5904

PLEASE ADHERE TO INSTRUCTIONS PUBLISHED IN THIS MANUAL.
 Failure to do so may be dangerous and may void certain provisions of your warranty.
 For further assistance, please call:

24 Hr. Hotline: 1-800-661-8529
 (U.S.A. and Canada)

Please have model and serial numbers available before calling.

WARRANTY: Under normal use the Company warrants to the purchaser that defects in material or workmanship will be repaired or replaced without charge for a period of 36 months from date of shipment. Any claim for warranty must be reported to the sales office where the product was purchased for authorized repair or replacement within the terms of this warranty.

Subject to State or Provincial law to the contrary, the Company will not be responsible for any expense for installation, removal from service, transportation, or damages of any type whatsoever, including damages arising from lack of use, business interruptions, or incidental or consequential damages.

The Company cannot anticipate or control the conditions of product usage and therefore accepts no responsibility for the safe application and suitability of its products when used alone or in combination with other products. Tests for the safe application and suitability of the products are the sole responsibility of the user.

This warranty will be void if, in the judgment of the Company, the damage, failure or defect is the result of:

- vibration, radiation, erosion, corrosion, process contamination, abnormal process conditions, temperature and pressures, unusual surges or pulsation, fouling, ordinary wear and tear, lack of maintenance, incorrectly applied utilities such as voltage, air, gas, water, and others or any combination of the aforementioned causes not specifically allowed for in the design conditions or
- any act or omission by the Purchaser, its agents, servants or independent contractors which for greater certainty, but not so as to limit the generality of the foregoing, includes physical, chemical or mechanical abuse, accident, improper installation of the product, improper storage and handling of the product, improper application or the misalignment of parts.

No warranty applies to paint finishes except for manufacturing defects apparent within 30 days from the date of installation.

The Company neither assumes nor authorizes any person to assume for it any other obligation or liability in connection with the product(s).

The Purchaser agrees that all warranty work required after the initial commissioning of the product will be provided only if the Company has been paid by the Purchaser in full accordance with the terms and conditions of the contract.

The Purchaser agrees that the Company makes no warranty or guarantee, express, implied or statutory, **(INCLUDING ANY WARRANTY OF MERCHANTABILITY OR WARRANTY OF FITNESS FOR A PARTICULAR PURPOSE)** written or oral, of the Article or incidental labour, except as is expressed or contained in the agreement herein.

LIABILITY: Technical data contained in the catalog or on the website is subject to change without notice. The Company reserves the right to make dimensional and other design changes as required. The Purchaser acknowledges the Company shall not be obligated to modify those articles manufactured before the formulation of the changes in design or improvements of the products by the Company.

The Company shall not be liable to compensate or indemnify the Purchaser, end user or any other party against any actions, claims, liabilities, injury, loss, loss of use, loss of business, damages, indirect or consequential damages, demands, penalties, fines, expenses (including legal expenses), costs, obligations and causes of action of any kind arising wholly or partly from negligence or omission of the user or the misuse, incorrect application, unsafe application, incorrect storage and handling, incorrect installation, lack of maintenance, improper maintenance or improper operation of products furnished by the Company.

Edmonton
Head Office
 1-800-661-8529
 (780) 466-3178
 F 780-468-5904

Oakville
 1-800-410-3131
 (905) 829-4422
 F 905-829-4430

Orillia
 1-877-325-3473
 (705) 325-3473
 F 705-325-2106

Houston
 1-855-219-2101
 (281) 506-2310
 F 281-506-2316

Denver
 (303) 979-7339
 F 303-979-7350

DIRECTIVE 2003/108/EC AMMENDMENT TO THE DIRECTIVE 2002/96/EC OF THE EUROPEAN PARLIAMENT AND OF THE COUNCIL on waste electrical and electronic equipment (WEEE).

1. The equipment that you bought is WEEE marked and has required the extraction and use of natural resources for its production. It may contain substances that could impact health and the environment. As such it is a requirement not to dispose of WEEE marked equipment as unsorted municipal waste and to collect such WEEE marked equipment separately.
2. In order to avoid the dissemination of those substances in our environment and to diminish the pressure on natural resources, we encourage you to use the appropriate take-back systems in your area. Those systems will reuse or recycle most if not all of the materials of your equipment in a sound way.
3. The crossed-out wheeled bin symbol on this equipment invites you to use those systems.
4. If you need more information on collection, reuse and recycling systems in your area, please contact your local or regional waste management administration.

