

# ELECTRIC HEATER

## Engineering & Application Guide



Equipment selection, system design, and sample applications for electric heaters.

### **⚠ WARNING**



Consult the Installation, Operation, and Maintenance Manual(s) for specific requirements regarding clearances to combustibles, minimum mounting heights, and system design guidelines.

# Guide to Selecting the Right Electric Heater

## Mounting Heights

Traditionally, outdoor or spot heating requires the heating equipment to be mounted lower or closer to the people enjoying the heat. Lowering the equipment may result in less coverage but will offer a more focused heat pattern to the desired area. The final mounting height of the heater may need to be adjusted to achieve the results desired by the customer.

## Customer Expectations

Depending on the needs of the customer, more or fewer heaters may be required for a given application. There is rarely a “one size fits all” solution to properly size an electric heating application. Some customers may seek maximum comfort in extreme conditions while others may be looking to simply take the chill off, such as a work station or outdoor smoking area.

## Excessive Air Movement for Outdoor Applications

Wind is perhaps the largest variable when trying to achieve comfortable heating in an outdoor or spot-heating environment. While the heat output of electric heaters is unaffected by wind, the comfort of the people below can still be diminished by the effects of wind. The use of barricades such as wind curtains is highly recommended whenever possible.

# Look to the Experts in Heating

Since 1955, Detroit Radiant Products Company has been setting the standard for high-quality, cost-effective, energy-efficient infrared heaters. Re-Verber-Ray® brand products are recognized as a solution for most commercial, industrial, and specialty applications. Our manufacturing flexibility and efficiencies are a key element in providing optimal customer service and application-specific heating solutions.

Stylish and easy to install, the electric heater series offered by Re-Verber-Ray® have been designed specifically to add warmth to outdoor environments or to heat indoor spaces where gas is not available. Whether you are looking to extend your local season, need to make additional room for peak crowds, or heat employee work areas, our broad offering can provide a solution that will fit your heating needs.

## Product Feature Key



Water Resistant



Adjustable Mounting



Recess Option



IP55 Rated



Visible Light



Even Heat Distribution



Wind Resistant



Intense Heat Output

# Electric Infrared Heaters

Electric infrared heaters are a great choice when there is not gas available for gas-fired patio heaters, or when there are space or clearance to combustibles constraints that prevent the installation of a gas-fired unit. Electric heaters are 100% efficient and have no venting requirements. With a wide range of available voltages and light-emitting and no-light models, these heaters are a great solution for a myriad of applications.

## PROS

- Wide range of available voltages
- Compact
- Light-emitting and low-light models available
- Ultra high efficiencies
- No venting required
- Lower cost per unit
- Heat output isn't affected by wind

## CONS

- Higher amp draw per heater
- Require more units when compared to gas-fired options
- Costly to operate compared to gas-fired options
- Controls can become complex and pricey



# Indoor/Outdoor Electric Heating Questionnaire

Please make copies of this sheet for additional questionnaires.

Is this application commercial or residential?  Residential  Commercial

Is this application indoor or outdoor?  Indoor  Outdoor

What voltage is required (120, 208, 240, 277, 480, 575)? \_\_\_\_\_ Approx. amperage?\* \_\_\_\_\_

What service is provided at the site?\*  Single Phase  Three Phase

\* All electric infrared heaters are built as single phase. If three phase service is available at the job site, design in multiples of three (heaters or elements) and divide the heater's amps by 1.73.

What are the dimensions of the area being heated? \_\_\_\_\_

What is the material of the roof/deck structure above the heater? \_\_\_\_\_

What is the height of the structure above the heater? \_\_\_\_\_

What is the main purpose of heating (spot heating, whole bldg. heat, smoking area, dining, etc.)? \_\_\_\_\_

If outdoor patio, will the area be closed in with curtains or glass during usage months? \_\_\_\_\_

What is your expectation for heat (comfort, year-round heating\*\*, etc.)? \_\_\_\_\_

\*\*A typical heating system will not be able to overcome all weather conditions, particularly during colder and breezier periods.

Any additional information? \_\_\_\_\_

Please sketch your application below including where obstacles/furnishings will be located.

**Floor Plan** (Include dimensions, location of all doors and windows)

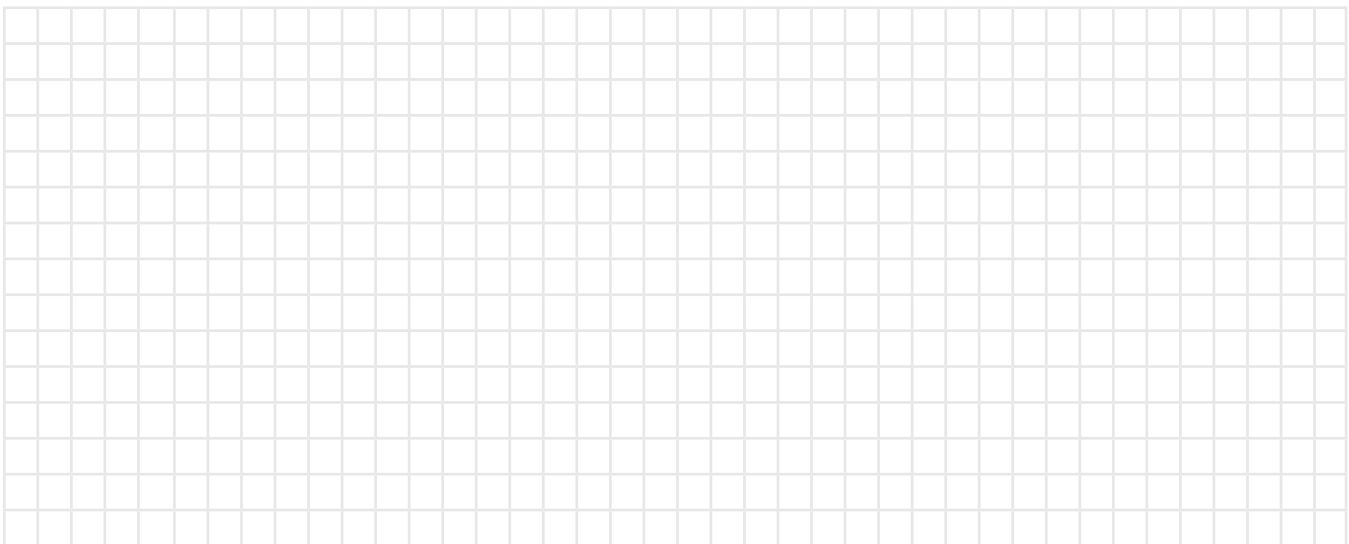

**Patio Elevation Details:** (Note dimensions and interior obstructions such as fans or lights)

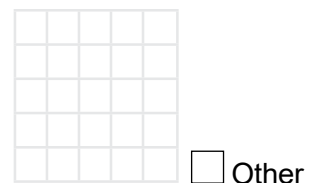
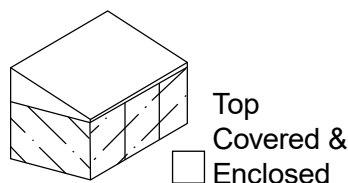
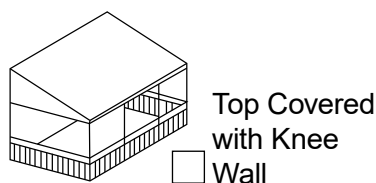
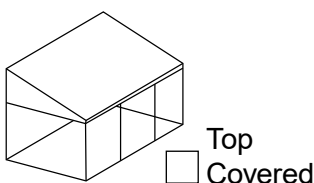

**ESTIMATING REQUIRED LOADS FOR PERCEIVED 10–15° OUTDOOR TEMP. RISE**

Type of Building	Watts Required per Sq. Ft. at Floor Level*
Insulated	5–10
Uninsulated	10–15
Outdoor Sheltered	20–30
Outdoor Unsheltered	25–40

\*For load purposes only, not for determining coverage.

Add the following watts per square foot for the following temperatures below zero:

- 5 Add 0.75 watts per square foot
- 10 Add 1.50 watts per square foot
- 15 Add 2.25 watts per square foot
- 20 Add 3.00 watts per square foot

IMPORTANT: The table above is designed for a mounting height of 9 feet above floor level.

For higher mountings, add 10% of the total watts for each foot above 9 feet.

For lower than 9 feet mountings, deduct 10% of the total watts for each foot below 9 feet.

More heaters may be needed to provide adequate coverage for the space. Typical height above patrons is 2–6 ft.

**ELX SERIES APPLICATION CHART**

Series	Lamp Quantity	Minimum Mounting Height		Recommended Mounting Height (Ft.)	Recommended Distance Between Heaters (Ft.)	Approximate Square Foot Coverage**
		US (ft.)	Canada (m)			
ELX-24	1	6	2.4	10 to 12	5 to 10	100 to 200
	2	7.5	2.4	10 to 12	6 to 12	150 to 250
	3	9	2.8	12 to 14	7 to 14	200 to 300
ELX-33	1	6	2.4	10 to 12	6 to 12	200 to 300
	2	7.5	2.4	12 to 14	7 to 14	250 to 350
	3	9	2.8	12 to 14	8 to 16	300 to 400
ELX-46	1	6	2.4	12 to 14	7 to 14	300 to 400
	2	7.5	2.4	14 to 16	8 to 16	350 to 450
	3	9	2.8	14 to 16	9 to 18	400 to 500

\*\* Approximation only. Mounting height and environmental conditions will impact performance.

**DSS SERIES APPLICATION CHART**













Model	Lamp Quantity	Recommended Mounting Height (Ft.)	Recommended Distance Between Heaters (Ft.)
DSS-35B1-A15	1	6 to 8	3 to 9
DSS-35B1-C25	1	7 to 11	1 to 11

**DGS SERIES APPLICATION CHART**

Series	Lamp Quantity	Recommended Mounting Height (Ft.)	Recommended Distance Between Heaters (Ft.)
DGS-15	1	7 to 9	3 to 9
DGS-20	1	7 to 9	4 to 11

**BAH SERIES APPLICATION CHART**

Series	Lamp Quantity	Recommended Mounting Height (Ft.)	Recommended Distance Between Heaters (Ft.)
BAH-25	1	7 to 9	3 to 9
BAH-35	1	8 to 10	4 to 11
BAH-45	1	9 to 11	5 to 13
BAH-60	1	10 to 12	6 to 15

FEATURES	ELX SERIES EL-MW ELEMENTS	ELX SERIES EL-HO ELEMENTS	ELX SERIES EL-SC & EL-SR ELEMENTS	DSS SERIES	DGS SERIES	BAH SERIES
Wavelength Type	Standard Medium Wave	High-Output Medium Wave	Short Wave (Clear or Ruby)	Medium Wave	Filtered Short Wave	Medium Wave
Available Chassis Lengths	24", 33", or 46"	24", 33", or 46"	24", 33", or 46"	34.5"	21.06"	25", 35", 45", or 60"
Number of Elements	1, 2, or 3	1, 2, or 3	1, 2, or 3	1	1	1
Available Voltages	120, 208, 240, 277, 480, or 575	120, 208, 240, 277, 480, or 575	120, 208, 240, 277, 480, or 575	120 or 230	120 or 230	120, 208, or 240
Wattage Range	750 to 9,000	1,360 to 9,600	1,500 to 11,400	1,500 to 2,500	1,500 to 2,000	1,000 to 4,000
BTU Equivalent Range	2,559 to 30,709 BTU/h	4,641 to 32,757 BTU/h	5,118 to 38,898 BTU/h	5,118 to 8,530 BTU/h	5,118 to 6,824 BTU/h	3,400 to 13,500 BTU/h
Element Type	Coiled Tungsten	Woven Tungsten	Coiled Tungsten	Carbon Fiber	Halogen	Coiled Tungsten
Element Color	Clear	Clear	Clear or Ruby	Clear	Gold-Filtered Ruby	Clear
Ideal Applications	Romantic restaurants, outdoor patios, and other areas where light is not needed or desired.	Spot heating, indoor and outdoor commercial, outdoor patios, and other areas where more heat is required but the brightness of the short wave is not.	Spot heating, indoor and outdoor commercial, valet waiting areas, and other areas where visible light is desired.	Residential patios, workstations, and other smaller areas where moderate heat is required but visible light is not.	Residential patios, restaurant patios, and other smaller areas where more heat is required and the moderately bright light is acceptable.	Indoor spot heating, shop offices, workstations, and other areas indoors where moderate heat is required but a lot of visible light is not.
Brightness Level						
Color	Soft Orange	White	Bright White or Ruby	Mild White	Moderate Ruby	Mild White
Heat Speed	Short	Short	Instant-On	Short	Instant-On	Short
Certification						
Limited Warranty	1-Year All Components	1-Year All Components	1-Year All Components	1-Year All Components	1-Year All Components	1-Year All Components
Indoor Approvals	Commercial Industrial	Commercial Industrial	Commercial Industrial	Commercial Industrial	Commercial Industrial	Commercial Industrial
Outdoor Approvals	Commercial Industrial Residential	Commercial Industrial Residential	Commercial Industrial Residential	Commercial Industrial Residential	Commercial Industrial Residential	N/A
Recessed Mount Available	Single Element Double Element	Single Element Double Element	Single Element Double Element	N/A	N/A	N/A
Typ. Height Above Patrons <sup>1</sup>	2 to 6 feet	2 to 6 feet	2 to 6 feet	2 to 6 feet	2 to 6 feet	2 to 6 feet

<sup>1</sup>Typ. Height Above Patrons are recommended and are provided as a guideline only. Actual conditions will dictate variations from the above data. Clearances to combustibles must always be maintained.

## Heater Output Comparison

**ELX Series' standard medium wave** elements produce a soft, orange glow after reaching operating temperature. There is almost no visible light on walls or at the ground level. They typically have around half the wattage output of the other element types. Standard medium wave elements are perfect for restaurant patios and other areas where light is not needed.



**Standard Medium Wave**



**High-Output Medium Wave**

**ELX Series' high-output medium wave** elements produce a mild white light while operating. Light is visible on walls and at the ground level, but is around 30% less bright than a typical short wave element. However, high-output medium wave elements have an output equal to their short wave counterparts, making them the preferred choice for spot heating, outdoor patios, and other applications where more heat is required but the short wave elements' intense brightness is not.

**ELX Series' clear short wave** elements have a high heat output and produce a bright, white light that is very visible on walls and at ground level. They are commonly used for spot heating, indoor and outdoor commercial applications, valet waiting areas, and other spaces where a lot of visible light is desired in addition to a high heat output.



**Clear Short Wave**



**Ruby Short Wave**

**ELX Series' ruby short wave** elements have a glare-reducing ruby glass that produces a visible red light. With their high heat output and high light output, a bright, red light is very noticeable on the walls and ground level. These elements are commonly used in applications that require both heat and visible light, but where glare-reduction is also desired. For installations requiring multiple heaters, ruby elements are typically not advised as their red light can be overwhelming.

**DSS Series' medium wave** high efficiency carbon fiber elements produce a mild white light. With their moderate heat output and low light output, very little light can be seen on the walls and ground level. These heaters are commonly used in outdoor residential patio applications and other smaller outdoor areas where spot heating, comfort heating, or even total heating are desired.

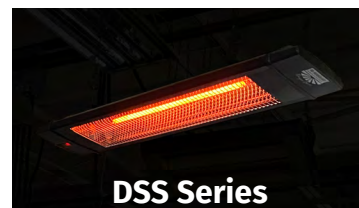

**DSS Series**

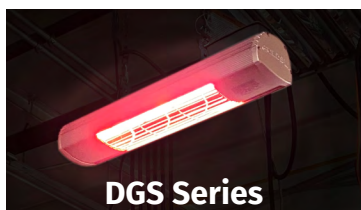

**DGS Series**

**DGS Series' short wave** gold-filtered ruby halogen elements produce a moderately bright ruby light. With their mid to high heat output and smaller form, less light can be seen on the walls and ground. Common applications for DGS Series heaters include outdoor residential patios, restaurant patios, and other smaller applications where higher heat is required.

**BAH Series' medium wave** elements produce very little visible light, so light is typically not seen on the walls or ground level. BAH Series heaters are commonly used in indoor shop offices, workstations, spot heating, and other areas where moderate heat is desired, but light is not.

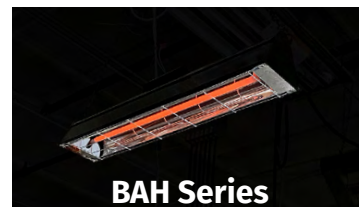

**BAH Series**

# ELX Series Electric Infrared Heater with Interchangeable Elements

Introducing our most versatile electric infrared heater yet. Featuring interchangeable elements, the ELX Series can utilize clear or ruby short wave, high-output medium wave, or standard medium wave elements. Short wave elements are perfect for spot heating applications or areas where a lot of light is required such as valet parking vestibules and parking garages. High-output medium wave elements offer the same heat

output as short wave, but with approximately 30% less visible light. Standard medium wave elements have around half the heat output of short wave, but produce a soft orange glow, making them perfect for patios, restaurants, and other areas where visible light is not desired. With three available lengths and single, double, or triple lamp models, the ELX Series is a great choice for a myriad of applications.



Models range from 750 to 11,400 watts (based on element type selected)  
Available in black or stainless steel finishes.

## KEY FEATURES

- Gold-colored anodized aluminum reflectors reduce glare
- 0° to 45° adjustable mounting brackets included
- Single, double, or triple lamp models
- Black powder-coated or brushed stainless steel housing
- Elements available in clear or ruby short wave, high-output medium wave, or standard medium wave
- High-temperature nylon end caps



## Specifications

SPECIFICATIONS	SHORT WAVE	H.O. MEDIUM WAVE	MEDIUM WAVE
<b>Electrical Consumption</b>	1,500 to 11,400 Watts	1,360 to 9,600 Watts	750 to 9,000 Watts
<b>Equivalent BTU</b>	5,118 to 38,898	4,641 to 32,757	2,559 to 30,709
<b>Voltage</b>	120 to 575 VAC		
<b>Lamp Element</b>	Clear or Ruby Short Wave	High-Output Medium Wave	Std. Medium Wave
<b>^Rcmd. Mounting Height</b>	Varies from 10 ft. to 16 ft. based on model		
<b>Weight</b>	Varies based on model		
<b>Approvals</b>	Outdoor Commercial Indoor Commercial Outdoor Residential		
<b>Limited Warranty</b>	1-year all components		
<b>Dimensions</b>	<b>A</b>	<b>B</b>	<b>C</b>
ELX-24X1	23.50"	9.625"	24.50"
ELX-24X2	23.50"	15.25"	24.50"
ELX-24X3	23.50"	21.00"	24.50"
ELX-33X1	32.50"	9.625"	33.50"
ELX-33X2	32.50"	15.25"	33.50"
ELX-33X3	32.50"	21.00"	33.50"
ELX-46X1	45.50"	9.625"	46.50"
ELX-46X2	45.50"	15.25"	46.50"
ELX-46X3	45.50"	21.00"	46.50"

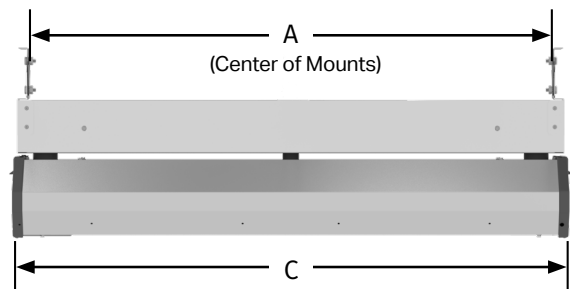
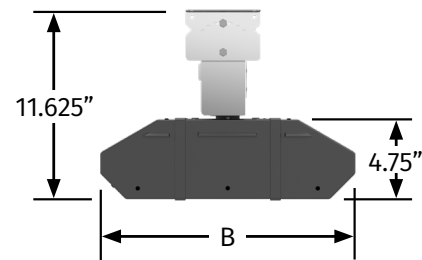

^ Typical or recommended mounting heights are provided as a guideline. Actual conditions may dictate variations from this data.

\* Based upon lab conditions with no wind & targeted 15° temperature rise. Site conditions may vary.

## Clearances to Combustibles

Length	Mounting Angle	Side		End	Top	Below	Min. Mtg. Height	
		Front	Behind				US	Canada
<b>Single Element</b>								
24" 33" 46"	0°	16 (407)	16 (407)	12 (305)	6 (153)	56 (1423)	6 ft.	2.4 m
	45°	47 (1194)	4 (102)	12 (305)	10 (254)	40 (1016)		
<b>Double Element</b>								
24" 33" 46"	0°	28 (712)	28 (712)	26 (661)	6 (153)	86 (2185)	7.5 ft.	2.4 m
	45°	86 (2185)	4 (102)	26 (661)	10 (254)	86 (2185)		
<b>Triple Element</b>								
24" 33" 46"	0°	31 (788)	31 (788)	34 (864)	9 (229)	105 (2667)	9 ft.	2.8 m
	45°	105 (2667)	4 (102)	34 (864)	10 (254)	105 (2667)		

\* Heaters mounted on an angle between 0° and 45° must maintain clearances posted for 0° or 45°, whichever is greater.

Clearances to combustibles distances represent a surface temperature of 90°F (50°C) above ambient temperature. Ensure that building materials with a low heat tolerance (i.e. awnings, fabrics, plastics, sprinklers, insulation) are protected against degradation. This may require the heater to be mounted at a distance in excess of the published clearances to combustibles. Contact the factory or the building material manufacturer for additional information.

## Sample Layouts

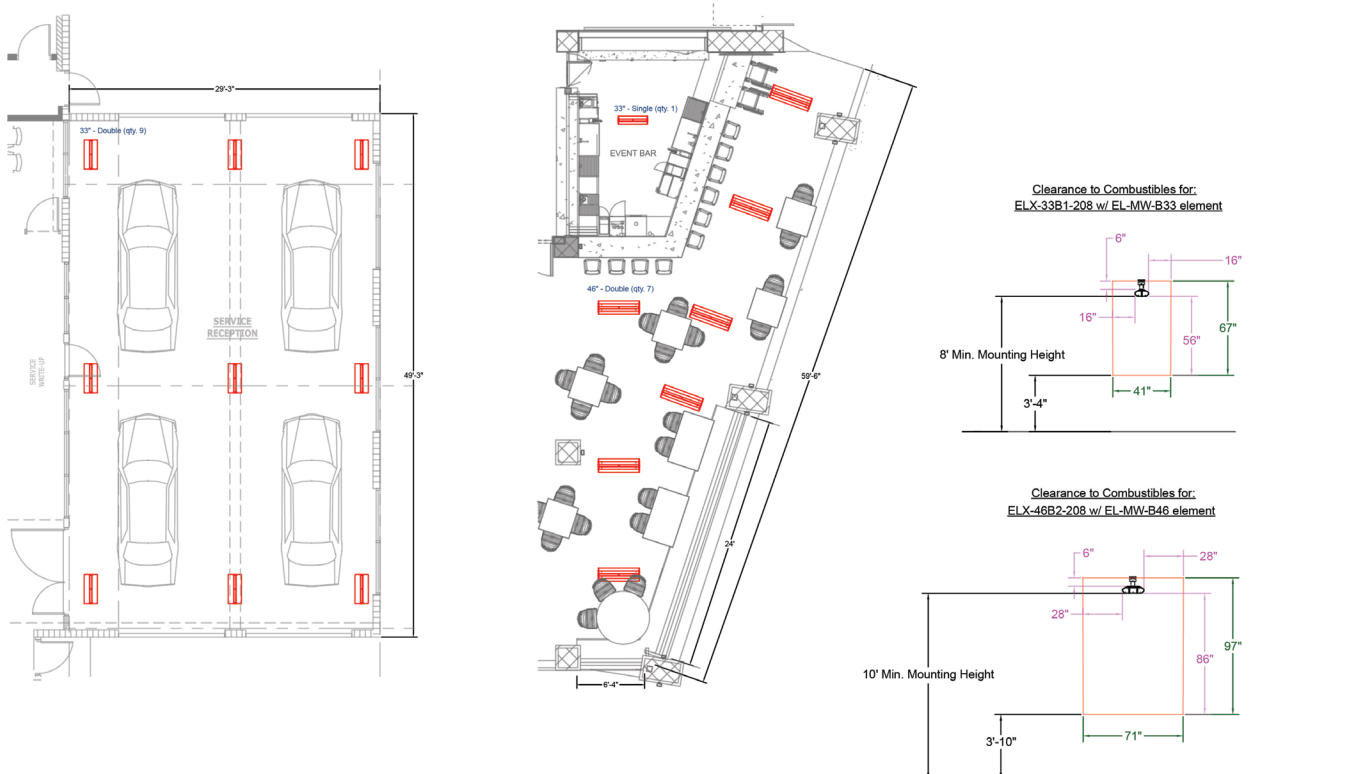

## DSS Series Medium Wave Electric Infrared Heater

Outdoor approved DSS Series heaters produce instant medium wave heat through the use of innovative carbon fiber lamps encased in an IP55 rated slim, compact, black enclosure. This heater offers a remote control with timer functionality and four power settings. Multiple heaters can be controlled by a single remote.

Operational benefits include a highly efficient energy transfer, even heat distribution, and intense heat output.



Models range from 1,500 to 2,500 watts.

### KEY FEATURES

- IP55 rated for outdoor use
- Compact, slim design
- Remote control with 4 power settings
- Overheat and tip-over protection
- High-efficiency carbon fiber lamps
- Consistent clearances to combustibles across all models



## Specifications

SPECIFICATIONS	DSS-35B-A15	DSS-35B1-C25
Electrical Consumption	1,500 Watts	2,500 Watts
Equivalent BTU	5,118	8,530
Voltage	120 VAC	230 VAC
Lamp Element	Carbon Fiber	
^Rcmd. Mounting Height	6 ft. to 8 ft.	7 ft. to 11 ft.
*Approx. Area Heated	75 sq. ft.	120 sq. ft.
Weight	6.6 lbs.	
Approvals	Outdoor Commercial Indoor Commercial Outdoor Residential	
Limited Warranty	1-year all components	

^ Typical or recommended mounting heights are provided as a guideline. Actual conditions may dictate variations from this data.

\* Based upon lab conditions with no wind & targeted 15° temperature rise. Site conditions may vary.

† This dimension doesn't include mounting bracket. Mounting bracket is 4" high in its vertical orientation without included angle bracket.

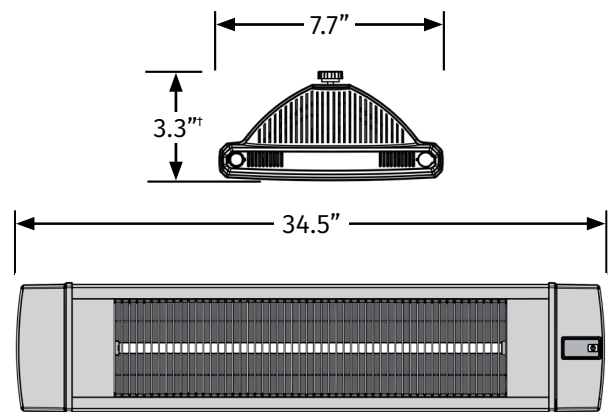

## Clearances to Combustibles

Model Wattage	Mounting Angle*	Side				
		Front	Behind	End	Top	Below
All Models	0°	13"	13"	11"	4"	50"
	45°	37"	2"	11"	5"	35"

\* Heaters mounted on an angle between 0° and 45° must maintain clearances posted for 0° or 45°, whichever is greater.

Clearances to combustibles distances represent a surface temperature of 90°F (50°C) above ambient temperature. Ensure that building materials with a low heat tolerance (i.e. awnings, fabrics, plastics, sprinklers, insulation) are protected against degradation. This may require the heater to be mounted at a distance in excess of the published clearances to combustibles. Contact the factory or the building material manufacturer for additional information.

## Sample Layout

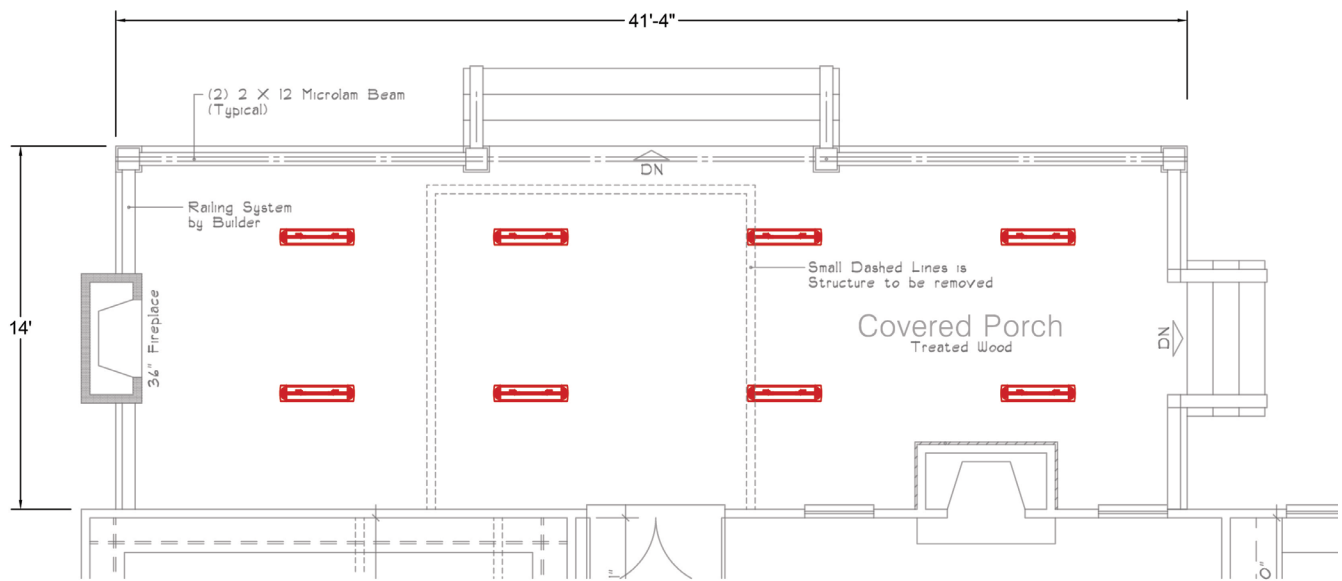

DSS Clearance to Combustible 0° Mount - Elevation View

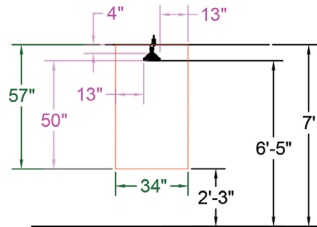

DSS Clearance to Combustible 45° Mount - Elevation View

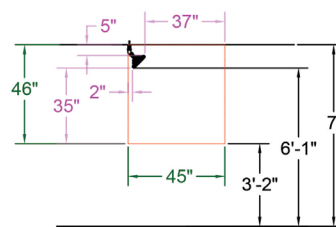

### TIPS:

- DSS Series heaters are IP55 rated. However, to ensure the longest possible service life, it is still recommended to ensure there is sufficient protection above the level of the heater (while maintaining clearances to combustibles) to protect against outside elements.

## DGS Series Filtered Short Wave Electric Infrared Heater

The DGS Series has proven to be an excellent option for electric heating that values aesthetics with its modern design and high-end quality. This heater features a custom designed reflector that focuses the desired heat pattern where you need it in your space. Thanks to its aluminum extruded body, the DGS Series

is easily able to withstand harsh outdoor conditions (IP55 rated), allowing you to extend your residential patio or outdoor restaurant season. Plus, its sleek appearance adds style to any indoor or outdoor space, and all models feature a bronze color finish with gold filtered red lamps.



Models range from 1,500 to 2,000 watts.

**KEY FEATURES**

- Custom designed reflector
- High-end quality and compact, aesthetic design
- IP55 weatherproof
- High-capacity range

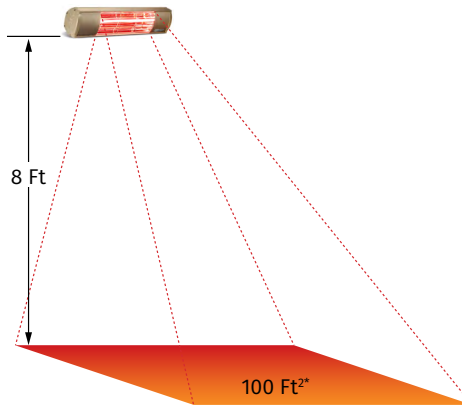

## Specifications

SPECIFICATIONS	DGS-15	DGS-20
<b>Electrical Consumption</b>	1,500 Watts	2,000 Watts
<b>Equivalent BTU</b>	5,118	6,824
<b>Voltage</b>	120 VAC	230 VAC
<b>Lamp Element</b>	Gold-Filtered Halogen	
<b>^Rcmd. Mounting Height</b>	7 ft. to 9 ft.	7 ft. to 9 ft.
<b>Weight</b>	5.7 lbs.	5.7 lbs.
<b>Approvals</b>	Outdoor Commercial Indoor Commercial Outdoor Residential	
<b>Limited Warranty</b>	1-year all components	

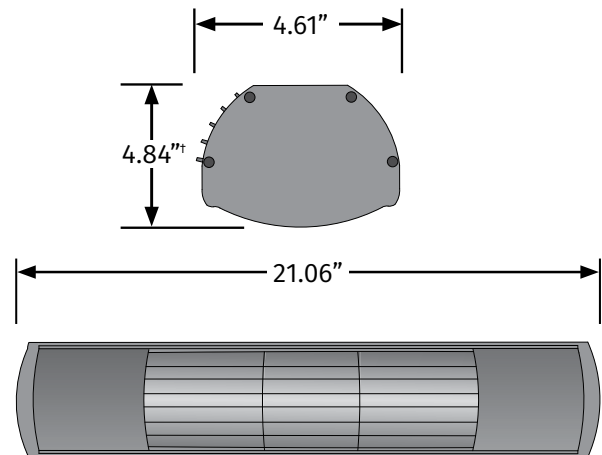

<sup>^</sup> Typical or recommended mounting heights are provided as a guideline. Actual conditions may dictate variations from this data.

<sup>\*</sup> Based upon lab conditions with no wind & targeted 15° temperature rise. Site conditions may vary.

<sup>†</sup> This dimension doesn't include mounting bracket. Mounting bracket is 3.25" high in its vertical orientation.

## Clearances to Combustibles

Model Wattage	Mounting Angle*	Side				
		Front	Behind	End	Top	Below
1,500	0°	10"	10"	21"	3"	64"
	45°	39"	3"	21"	3.5"	40"
2,000	0°	10"	10"	21"	3"	64"
	45°	39"	3"	21"	3.5"	40"
3,000	0°	13"	13"	25"	3.5"	77"
	45°	44"	3"	25"	5"	51"

\* Heaters mounted on an angle between 0° and 45° must maintain clearances posted for 0° or 45°, whichever is greater.

Clearances to combustibles distances represent a surface temperature of 90°F (50°C) above ambient temperature. Ensure that building materials with a low heat tolerance (i.e, awnings, fabrics, plastics, sprinklers, insulation) are protected against degradation. This may require the heater to be mounted at a distance in excess of the published clearances to combustibles. Contact the factory or the building material manufacturer for additional information.

## Sample Layout

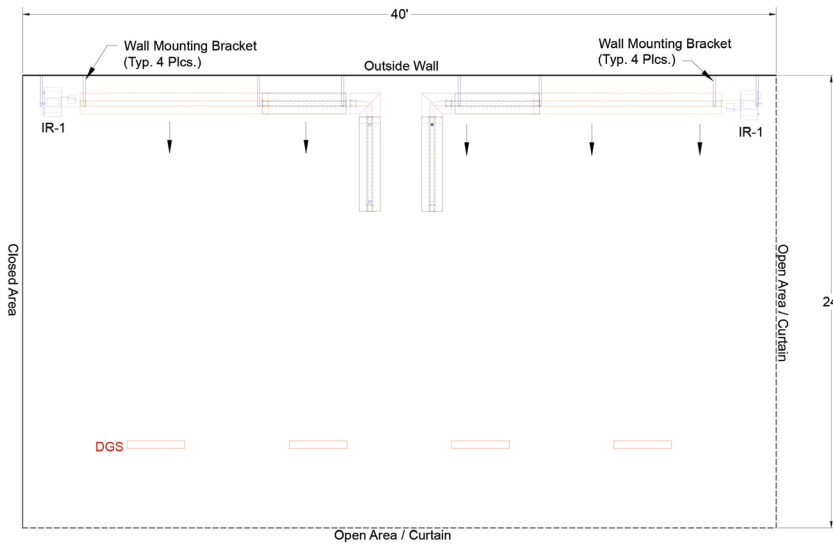

DGS-Z2-C30 Clearance to Combustible 0° Mount - Elevation View

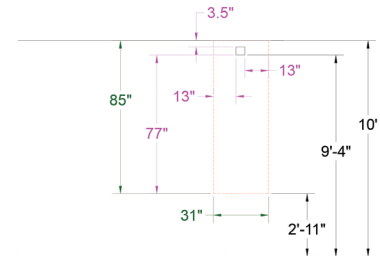

DGS-Z2-C30 Clearance to Combustible 45° Mount - Elevation View

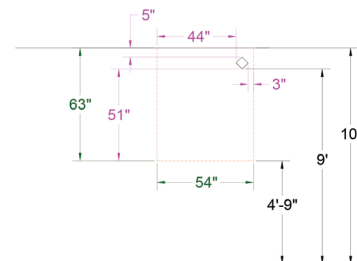

### TIPS:

- The below clearance is less when heaters are mounted on an angle.

## BAH Series Electric Infrared Heater

The BAH Series is a time-tested electric heater perfect for many types of indoor applications. Its mild white, medium wave element works well for areas where moderate heat is desired, but excessive visible light is not. The black-coated chassis is sturdy and aesthetically pleasing for a heater that is functional, yet unobtrusive.

With five heater lengths available, voltage options ranging from 120 to 575 VAC, and wattage choices from 1,000 to 4,000 W, the BAH Series works well for spot heating, shop offices, workstations, and a myriad of other indoor applications.

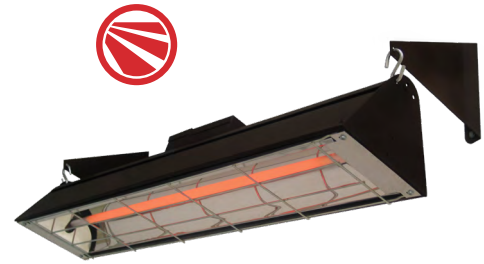

Models range from 1,000 to 4,000 watts

### KEY FEATURES

- Black-coated chassis design
- Available in five different lengths
- 0° to 20° adjustable mounting brackets included
- Consistent clearances to combustibles across all models



## Specifications

SPECIFICATIONS	ALL MODELS
<b>Electrical Consumption</b>	1,000 to 4,000 Watts
<b>Equivalent BTU</b>	3,400 to 13,500
<b>Voltage</b>	120 to 575 VAC
<b>Lamp Element</b>	Coiled Tungsten
<b>^Rcmd. Mounting Height</b>	Varies from 7 ft. to 12 ft. based on model
<b>Weight</b>	Varies based on model
<b>Approvals</b>	Indoor Commercial
<b>Limited Warranty</b>	1-year all components
<b>Dimensions</b>	<b>A</b>
BAH-25	25.00"
BAH-35	35.00"
BAH-45	45.00"
BAH-60	60.00"

^ Typical or recommended mounting heights are provided as a guideline. Actual conditions may dictate variations from this data.

\* Based upon lab conditions with no wind & targeted 15° temperature rise. Site conditions may vary.

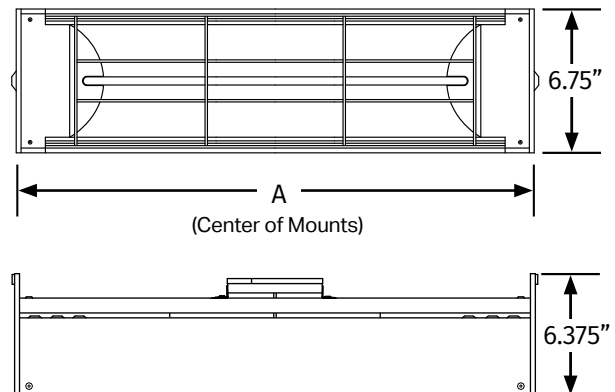

## Clearances to Combustibles

Model Wattage	Mounting Angle*	Side				
		Front	Behind	End	Top	Below
All Models	0°	18"	18"	24"	12"	24"
	20°	18"	18"	24"	12"	24"

\* Heaters mounted on an angle between 0° and 20° must maintain clearances posted for 0° or 20°, whichever is greater.

Clearances to combustibles distances represent a surface temperature of 90°F (50°C) above ambient temperature. Ensure that building materials with a low heat tolerance (i.e. awnings, fabrics, plastics, sprinklers, insulation) are protected against degradation. This may require the heater to be mounted at a distance in excess of the published clearances to combustibles. Contact the factory or the building material manufacturer for additional information.

## Sample Layout

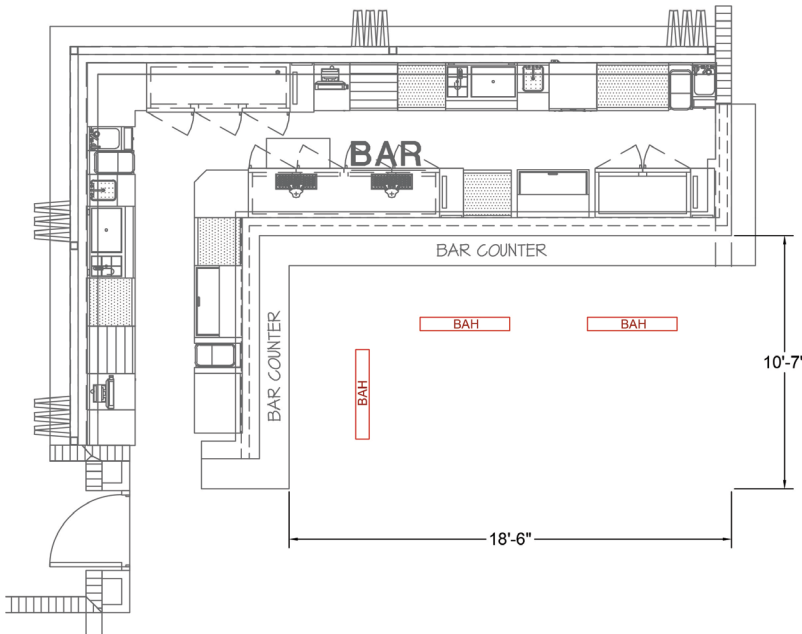

BAH All Models Clearance to Combustible 0° Mount - Elevation View

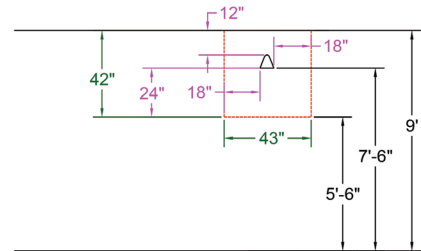

BAH All Models Clearance to Combustible 20° Mount - Elevation View

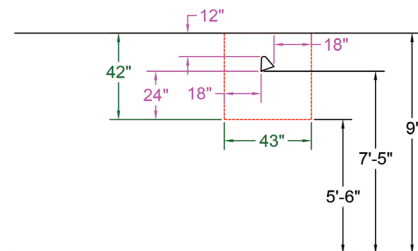



**DETROIT RADIANT**  
**PRODUCTS COMPANY**

21400 Hoover Rd. • Warren, MI 48089

Voice: (586) 756-0950 • Fax: (586) 756-2626

E-mail: [sales@drp-co.com](mailto:sales@drp-co.com) • Website: [www.detroitradiant.com](http://www.detroitradiant.com)