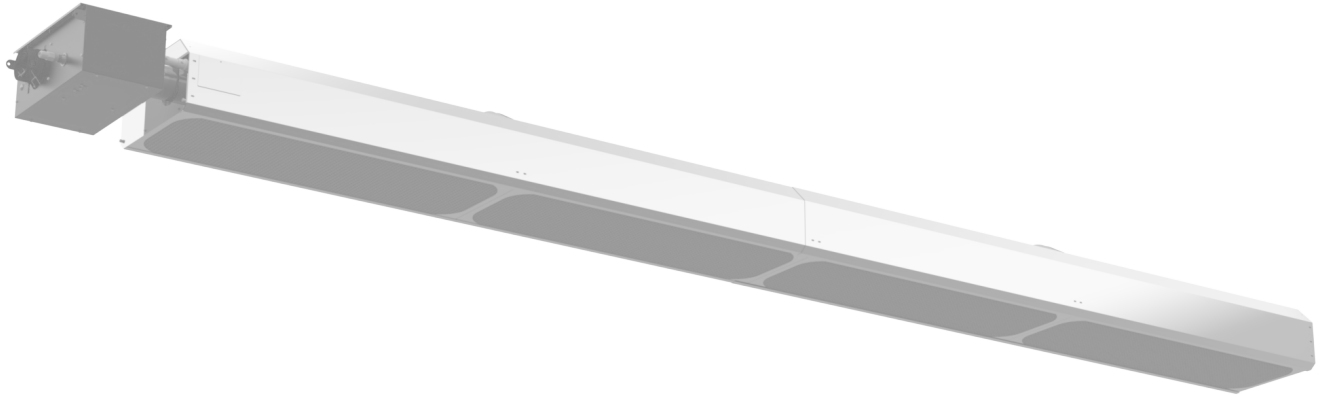


# DSRF Series Installation Manual



The DSRF Series Infrared Patio Heater is a positive pressure, two stage radiant heater system designed for unvented use outdoors. This manual provides specific information related to the DSRF Series models. All persons involved with the installation, operation, and maintenance of the heater system must read and understand the information in this manual.

## ⚠ WARNING



Improper installation, adjustment, alteration, service, or maintenance can cause property damage, injury, or death. Read the installation, operation, and maintenance instructions thoroughly before installing or servicing this equipment.

This heater must be installed and serviced by trained gas installation and service personnel only. Failure to comply could result in personal injury, asphyxiation, death, fire, or property damage.



In locations used for the storage of combustible materials, signs must be posted to specify the maximum permissible stacking height to maintain the required clearances from the heater to the combustibles. Signs must either be posted adjacent to the heater thermostats or, in the absence of such thermostats, in a conspicuous location.



**Not for indoor residential use!** Do not use this heater in the home, sleeping quarters, attached garages, etc. **Installation of a commercial tube heater system in residential indoor spaces may result in property damage, serious injury, asphyxiation, or death.**

## For Your Safety

### If you smell gas:

- Do not try to light any appliance.
- Do not touch any electrical switch.
- Do not use any phone in your building.
- Immediately call your gas supplier from a neighbor's phone.
- Follow the gas supplier's instructions.
- If you cannot reach your gas supplier, call the fire department.

### INSTALLER: Present this manual to the end user.

Keep these instructions in a clean and dry place for future reference.

Model#: \_\_\_\_\_ Serial #: \_\_\_\_\_  
(located on rating label)

LIODSRF-Rev. 33823  
Print: Xc-08/25 (DRPC)

# Contents

---

<b>1.0 Introduction</b> .....	<b>3</b>
Overview .....	3
Heater Components .....	3
Specifications .....	3
Safety Labels and Their Locations .....	4
<b>2.0 Safety</b> .....	<b>6</b>
Applications .....	6
Standards, Certifications, and Government Regulations .....	7
Clearances to Combustibles .....	8
<b>3.0 Installation</b> .....	<b>10</b>
Design Considerations and Prechecks .....	10
Recommended Mounting Heights .....	11
Heater Assembly Instructions .....	12
Heater Placement and Suspension .....	15
Sway Bracing for High Air Movement and Outdoor Applications .....	16
Venting .....	18
Gas Supply Installation Instructions .....	28
Installation of the Gas Line to the Heater .....	30
Leak Testing .....	33
Electrical Requirements and Wiring Diagrams .....	34
Field Wiring Supply Voltage .....	35
Thermostat Connection .....	36
<b>4.0 Operation</b> .....	<b>37</b>
Sequence of Operation .....	37
Diagnostics .....	38
<b>5.0 Troubleshooting Guide</b> .....	<b>40</b>
<b>6.0 Maintenance</b> .....	<b>44</b>
Routine Maintenance and Inspection .....	44
Maintenance Log .....	45
<b>7.0 Parts</b> .....	<b>46</b>
Burner Assembly Components .....	46
Tube and Reflector Components .....	47
Limited Warranty Terms and Conditions .....	48
Kit Contents Check List .....	52

# 1.0 Introduction

## Overview

The intent of this manual is to provide information regarding general safety, installation, operation, and maintenance of this radiant tube heater. You must read and understand all instructions and safety warnings before installing or servicing the radiant tube heater.

## Heater Components

Prior to installation, verify that the heater’s gas type and voltage (as listed on the rating plate) match that of your application. Also verify that you have received all heater components included with your radiant tube heater. Refer to page 52 for a list of the kit contents for your series heater. Materials not included in the heater kit contents (e.g., screws, terminals, etc.) are the responsibility of the installer. Notify your product representative or Detroit Radiant Products of any discrepancy or missing kit contents prior to installing unit.

## Specifications

Chart 1.1 • DSRF Specifications

Model Number	Gas Type (Select One)	BTU/h (High Fire)	BTU/h (Low Fire)	Length	Unit Weight (lbs.)	Recommended Mounting Height*	Radiant Surface Area (sq. ft.)	36" Baffle Sections
DSRF-30-65	Nat. or Prop.	65,000	50,000	16'-4"	170	9' to 16'	26.7	4
DSRF-30-80	Nat. or Prop.	80,000	52,000	16'-4"	170	9' to 16'	26.7	4
DSRF-35-65	Nat. or Prop.	65,000	50,000	21'-10"	225	9' to 16'	38.1	4
DSRF-35-80	Nat. or Prop.	80,000	52,000	21'-10"	225	9' to 16'	38.1	5
DSRF-35-100	Nat. or Prop.	100,000	65,000	21'-10"	225	9' to 16'	38.1	5

\* Typical or recommended mounting heights are provided as a guideline. Actual conditions may dictate variations from this data.

### WARNING

#### California Proposition 65

This product can expose you to chemicals including lead and carbon monoxide, which are known to the State of California to cause birth defects or other reproductive harm.

For more information, go to [www.P65Warnings.ca.gov](http://www.P65Warnings.ca.gov).

# ⚠ WARNING

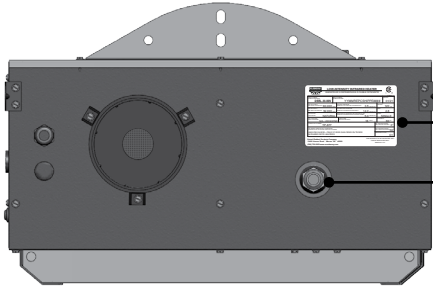


Read and understand all safety information and warnings in this manual before installation, operation, and maintenance of the radiant tube heater system.

## Safety Labels and Their Locations

Product safety signs or labels should be replaced by the product user when they no longer are legible. Contact either your local distributor or the product manufacturer for obtaining replacement signs or labels.

Back Panel



**LOW-INTENSITY INFRARED HEATER**  
RADIATEUR À INFRAROUGE À FAIBLE INTENSITÉ

MODEL NUMBER <b>DSRF-30-80N</b>	MANUFACTURE NUMBER BY SERIAL <b>YMMREPCSHIPPE###</b>	DATE MADE <b>01/24</b>
MAX. HEAT OUTPUT <b>80,000 BTU/H</b>	HEATING CAPACITY <b>120 sq. ft.</b>	MAX. HEAT INPUT <b>52,000 BTU/H</b>
FUEL TYPE <b>NATURAL</b>	VENTING TYPE <b>UNVENTED</b>	VENTING SIZE <b>1.8 in.</b>
VENTING CATEGORY <b>TP-87</b>	VENTING HEIGHT <b>18 in.</b>	VENTING TYPE <b>0"</b>
CLEARANCE TO COMBUSTIBLES (in inches)		VENTING TYPE <b>30"</b>
ANSI Z83.24-2020 • CSA 2.37-2020 GAS-FIRED OUTDOOR INFRARED PATIO HEATERS		VENTING TYPE <b>C1</b>
ANSI Z83.20-2016 • CSA 2.36-2016 GAS-FIRED LOW-INTENSITY TUBE HEATERS		

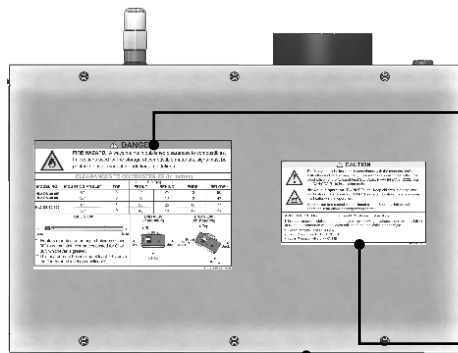
Detroit Radiant Products Company  
21400 Howe Road, Warren, MI 48090  
(586) 756-0950 www.reverber-ray.com

Rating Plate

F/N: LLTB018 (Natural Gas)  
F/N: LLTB019 (Propane Gas)



Top Panel



**⚠ DANGER**  
FIRE HAZARD. Always maintain published clearances to combustibles. In locations used for the storage of combustible materials, signs must be posted. Consult manual for additional guidelines.  
**This heater must be installed at least 7'9" above the floor/ground level (as applicable).**

CLEARANCES TO COMBUSTIBLES (in inches)

MODEL NO.	MOUNTING ANGLE*	TOP	FRONT	BEHIND	ENDS	BELOW
DSRF-30-80, 800	0°	9	25	25	12	60
DSRF-30-39-(95, 80)	30°	9	36	10	12	47
DSRF-30-180	0°	6	25	25	12	77
DSRF-30-100	30°	9	45	10	12	64

\* Heaters mounted on an angle between 0° and 30° must maintain clearances posted for 0° or 30°, whichever is greater.

F/N: LLTCL018  
Clearances to Combustibles Label

**⚠ CAUTION**

This heater must be installed in accordance with the manufacturer's instruction and local codes, if any. In absence of local codes, follow the latest edition of the National Fuel Gas Code, NFPA 54 (ANSI Z223.1) or the CAN/CSA B149 installation codes.

**Hot while in operation. DO NOT Touch.** Keep children, clothing, and combustible materials away. **DO NOT** store combustible materials under this heater while in operation.

Keep burner and control compartment clean. See installation and operating instructions accompanying heater.

**APPLICATION:** Minimum mounting height 7'9" above finished floor. If this appliance is installed in one or more of the following locations, then the installation must be in accordance with the latest edition of the applicable standard(s):

- Aircraft Hangars - ANSI / NFPA 409
- Parking Structure - ANSI / NFPA 88A
- Repair Garages - ANSI / NFPA 88B

F/N: LLTCL016a  
Safety Label

**DSRF-30-80N** Serial No.: 2312XXXXXXX 0001

Production Code: DSRP Stock:None  
Version: 0104 Add-On:NA

Data on this label is for the model shown on this label. If your heater has been converted, this information is not accurate. Please contact the factory for assistance.

**BURNER COMPONENTS:** (Specify TP-#s)

Gas Valve:	3E96-224-N	840	Diag. Unit:	On Circuit Board	N/A
Circuit Board:	MiniSO-24	851	Temp. Sensor:	None	N/A
Wire Harness:	3 PCS Harness	852	Temp. Switch:	40 VA	806
N.O. Switch:	None	N/A	Temp. Limit:	Fasco Lg.	85A
N.C. Switch:	None	N/A	Alt. Fan:	50Hz / 120V	558
N.C. Switch:	None	N/A	Alt. Fan Usage:	When Specified	N/A
N.C. V.I. Orifice:	None	N/A	Relay:	None	N/A
Diff. Switch:	1022-0000	204E	Shut-Off:	None	N/A
Diff. V.I. Orifice:	Grey	204E	24 Volt In.:	3 T-plug	832
Igniter:	Noton™	50	120 Volt In.:	2 x 4 Box	66
Burner:	Low-Mid	3072	Gas In.:	7/8" FC Flare	83
1" Tube:	4" Gen.	380	Extra V.I. Orifice:	None	
Hot Lights:	Yellow - 120V	828			

**Internal Use Only:**

HEATER TYPE:	Gas: TP-248	1	2	3	Electric: LLV1038	Special 1: MiniSO	
	Air: TP-448	1.12"	1.58"	1.95"	Tag:	None	Special 2: Plug-Wh.

For parts replacement information, contact factory at 586-756-0950 or visit www.drp-co.com/parts.

Burner Control Box  
Component Label (located under the top panel)

Bottom Panel



F/N: LLLOG0032



LED CODE	FAULT STATUS	FAULT CODE DELAY
Initial flash on power up, then steady off	No fault, normal operation	No delay
Steady on	Module failure / Internal fault	No delay
1 flash	Ignition failure	3 minutes
2 flashes	APS air flow fault NOTE: fan/intake/exhaust	1-30 seconds
4 flashes	Erroneous flame signal	No delay
No flash on 117V start-up	Transformer fault	No delay

**NOTE:** Lockout LED CODE appears on completion of the soft lockout operation.

Left Panel  
(Fan Compartment)

F/N: LLTB007(3)  
(Affixed under the lid)

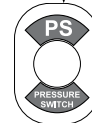
**WARNING**  
Avoid Serious Injury, Death, or Property Damage. Maintain Clearances to Combustible to Prevent the Risk of Fire.

**California Proposition 65**  
This product can expose you to chemicals including lead and carbon monoxide, which are known to the State of California to cause birth defects or other reproductive harm. For more information go to [www.P65Warnings.ca.gov](http://www.P65Warnings.ca.gov).

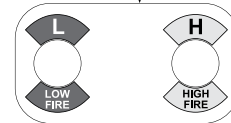
Clearances to combustibles must be maintained at all times in order to prevent the ignition of combustible materials. In locations used for the storage of combustible materials, signs must be posted to specify the maximum permissible stacking height to maintain the required clearances from the heater to the combustibles. Signs must either be posted adjacent to the heater's thermostats or, in the absence of such thermostats, in a conspicuous location. Clearances are provided on the heater's safety label and in the heater's Installation, Operation, and Maintenance manual. Product installation and operation must comply with applicable standards, codes, and regulations. Post this tag adjacent to the heater's thermostat or controls before operating the heater.

**- INSTALLER: READ AND POST THIS NOTICE -**

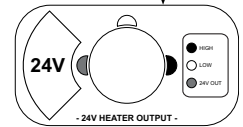
F/N: LL001 - Clearance Safety Tag  
(Affix adjacent to heater's thermostat)



F/N: LLV2EP15



F/N: LLV2EP9



F/N: LLV3EP4  
White Crescent

16" Burner Tube

Right Panel  
(Valve Compartment)

**SERVICE ACCESS PANEL**  
IGNITER & FLAME SENSE COMPARTMENT

1. Turn off gas & electricity.
2. Remove cover by lifting top cover upward and outward.

**CAUTION: HOT SURFACE.**  
KEEP COVER IN PLACE. REMOVE FOR SERVICE ONLY.

F/N: LLTB026

## 2.0 Safety

Read and understand all safety information and warnings in this manual prior to installation, operation, and maintenance of this tube heater. Warnings indicate a potentially hazardous situation which, if not avoided, could result in death or injury.

### ⚠ WARNING



Improper installation, adjustment, alteration, service, or maintenance can cause property damage, serious injury, or death. Read and understand the installation, operation, and maintenance instructions thoroughly before installing or servicing this equipment. Only trained qualified gas installation and service personnel may install or service this equipment.

### Warning Symbols

Safety is the most important consideration during installation, operation, and maintenance of the heater. You will see the following symbols and signal words when there is a hazard related to safety or property damage.

#### ⚠ WARNING

**Warning** indicates a potentially hazardous situation which, if not avoided, could result in death or injury.

#### ⚠ CAUTION

**Caution** indicates a potentially hazardous situation which, if not avoided, could result in minor or moderate injury.

#### NOTICE

**Notice** indicates a potentially hazardous situation which, if not avoided, could result in property damage.

### Applications

This is **not** an explosion proof heater. This heater may not be used in a Class 1 or Class 2 Explosive Environment. Consult your local fire marshal, insurance carrier, and other authorities for approval if the proposed installation is in question. ventilated to supply combustion air to the heaters and to sufficiently dilute

#### Patio

This patio heater is specifically designed to provide heated comfort in an **outdoor environment**. When properly integrated into a patio design, the heaters generally increase the comfort levels.

#### Commercial/Industrial Indoor

Unless otherwise indicated, tube heaters are designed and certified for use in industrial and commercial buildings such as warehouses, manufacturing plants, aircraft hangars, and vehicle maintenance shops. For maximum safety, the building must be evaluated for potential problems before installing the heating system. A critical safety factor to consider before installation is the clearances to combustibles.

#### High Altitude

The installation of this heater is approved, without modifications, for elevations up to 4,500 ft. above MSL (sea level). Contact Detroit Radiant Products Company for installations above these elevations. Installation of this appliance at altitudes above 4,500 ft. (1372 m) shall be in accordance with local codes or, in the absence of local codes, ANSI Z223.1/NFPA 54 or CSA B149.1.

## Standards, Certifications, and Government Regulations

Installation of this tube heater must conform with all applicable local, state, and national specifications, regulations, and building codes. Contact the local building inspector and/or fire marshal for guidance.

In the absence of local codes, the installation must conform to the latest edition of:

United States: National Fuel Gas Code, ANSI Z223.1 (NFPA 54).

Canada: CAN/CGA B149.1 and .2, Canadian Electrical Code C22.1

Copies of the standards can be viewed or purchased through their respective publishers.

### WARNING

**Not For Use in Indoor Living Spaces.** Installing this unit in residential indoor living spaces or sleeping quarters, such as bedrooms, basements, or garages, may result in property damage, serious injury, or death. This unit is approved for commercial/industrial use and **unvented outdoor residential use only.**

#### Sprinkler Heads:

Fire sprinkler heads must be located at an appropriate distance from the heater to avoid accidental discharge of the fire suppression system. This distance may exceed the published clearances to combustibles (see Chart 2.2 on page 9). Certain applications will require the use of a higher classification of sprinkler heads or relocation of the heaters. Chart 2.1 is derived from NFPA 13 Table 3-2.5.1. Some manufacturers may supply sprinklers with temperature ratings that vary from the chart below. Consult the manufacturer of the sprinkler heads and NFPA 13 for more information.

**Chart 2.1 • Sprinkler System Temperature Ratings**

Classification	Max. Ceiling Temperature	Sprinkler Activation Temperature	Glass Bulb Color	Fusible Link Color
Ordinary	100°F	135°F - 170°F	Orange (135°F) Red (155°F)	Black or No Color
Intermediate	150°F	175°F - 225°F	Yellow (175°F) Green (200°F)	White
High	225°F	250°F - 300°F	Blue	Blue
Extra High	300°F	325°F - 375°F	Purple	Red
Very Extra High	375°F	400°F - 475°F	Black	Green
Ultra High	475°F	500°F - 575°F	Black	Orange
Ultra High	625°F	650°F	Black	Orange

## Clearances to Combustibles

A critical safety factor to consider before installation is the clearances to combustibles. **Clearance to combustibles** is defined as the minimum distance you must have between the tube surface, or reflector, and the combustible item. Considerations must also be made for moving objects around the tube heater. The following is a partial list of items to maintain clearances from:

### Combustible items:

- Wood
- Paper
- Fabric
- Chemicals
- Paint
- Parked vehicles
- Gasoline
- Storage racks

### Moving Objects:

- Overhead doors
- Vehicle lifts
- Cranes
- Hoists

### Hazards:

For maximum safety the building must be evaluated for hazards before installing the heating system. Examples include, but are not limited to:

- Gas and electrical lines
- Combustible and explosive materials
- Chemical storage areas
- Areas of high chemical fume concentrations
- Provisions for accessibility to the heater
- Adequate clearances around air openings
- Combustion and ventilating air supply
- Vehicle parking areas
- Vehicles with lifts or cranes
- Storage areas with stacked materials
- Lights
- Sprinkler heads
- Overhead doors and tracks
- Dirty, contaminated environment

## ! WARNING



Placement of explosive objects, flammable objects, liquids, and vapors close to the heater may result in explosion, fire, property damage, serious injury, or death. Do not store or use explosive objects, liquids, and vapor in the vicinity of the heater.

## ! CAUTION

Children and adults should be alerted to the hazards of high surface temperatures and should stay away to avoid burns or clothing ignition.

Young children should be carefully supervised when they are in the same space as the heater.

Clothing or other flammable materials should not be hung from the heater or placed on or near the heater.

Any guard or other protective device removed for servicing the heater must be replaced prior to operating the heater.


Installation and repair should be done by a qualified service person. The heater should be inspected before use and at least annually by a qualified service person. More frequent cleaning may be required as necessary. It is imperative that the control compartment, air passageways, and burner(s) of the heater be kept clean.

When installing the heating system, the minimum clearances to combustibles for your series tube heater and system configuration must be maintained. These distances are shown in Chart 2.2 on page 9 and on the burner control box. If you are unsure of the potential hazards, consult your local fire marshal, fire insurance carrier, or other qualified authorities on the installation of gas fired tube heaters for approval of the proposed installation.

In locations used for the storage of combustible materials, signs must be posted to specify the maximum permissible stacking height to maintain the required clearances from the heater to the combustibles. Signs must either be posted adjacent to the heater's thermostat or in a conspicuous location.

The stated clearance to combustibles represents a surface temperature of 90°F (50°C) above room temperature. Building materials with a low heat tolerance (such as plastics, vinyl siding, canvas, tri-ply, etc.) may be subject to degradation at lower temperatures. It is the installer's responsibility to ensure that adjacent materials are protected from degradation.

## ⚠ WARNING



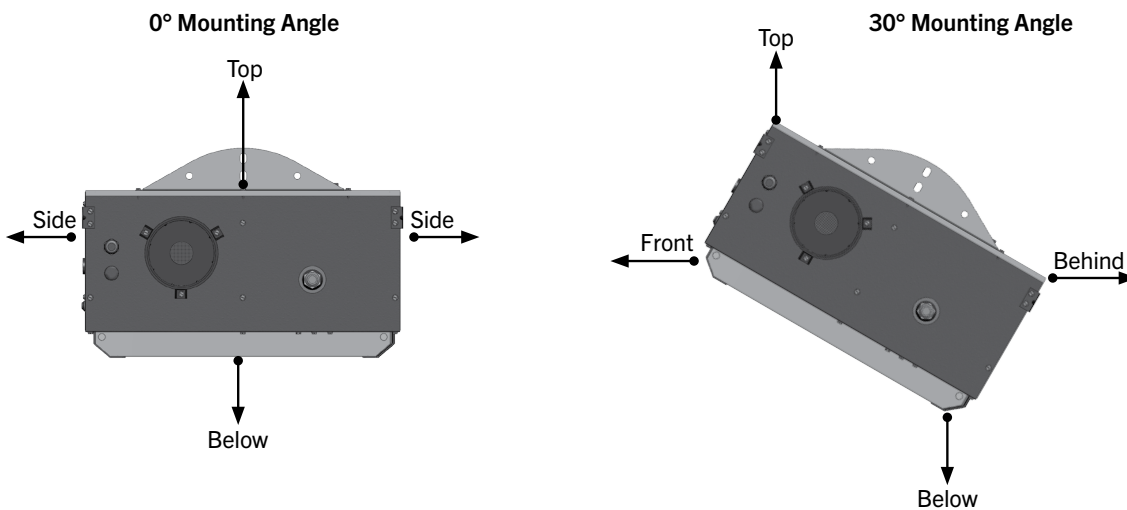
Failure to comply with the stated clearances to combustibles may result in personal injury, property damage, and/or death.

Chart 2.2 • Clearances to Combustible Materials in Inches (see Figure 2.1)

Model Number	Mounting Angle*	Sides		Top	Below	End
		Front	Behind			
DSRF-(30, 35)-65 [N, P]	0°	25	25	6	60	12
	30°	36	10	9	47	12
DSRF-(30, 35)-80 [N, P]	0°	25	25	6	60	12
	30°	36	10	9	47	12
DSRF-35-100 [N, P]	0°	25	25	6	77	12
	30°	45	10	9	64	12

\* Heaters mounted on an angle between 0° and 30° must maintain clearances posted for 0° or 30°, whichever is greater.

Figure 2.1 • Mounting Angles



## 3.0 Installation

### ⚠ WARNING



Improper installation, adjustment, alteration, service, or maintenance can cause property damage, serious injury, or death.

Read and understand the installation, operation, and maintenance instructions thoroughly before installing or servicing this equipment.

Only trained, qualified gas installation and service personnel may install or service this equipment.

### Design Considerations and Prechecks

Placement of infrared heaters is influenced by many factors. All installation manuals, along with national, state, and local codes, address these issues. It is critical that you read, understand, and follow all guidelines and instructions.

To ensure a properly designed heating system, a layout should be developed for the correct placement of the burner control box, tubes, and reflectors. Inspect and evaluate the mounting conditions, gas supply, and wiring.

**When designing an infrared radiant heating system for a patio, consider the following:**

- Has the building's heat loss been evaluated?
- Does the design meet the needs of the space?
- Have recommended mounting heights been observed?
- Have all clearance to combustible situations been observed?
- Is the supply (burner) end of the heater located where more heat is required?
- Is it best to offset the heaters and/or rotate the reflectors towards the heat zone?
- Are extra guards, side shields, 'U' or 'L' reflector covers required?
- Does the heater require outside fresh air for combustion?
- Is the environment harsh or contaminated (requiring outside air for combustion)?
- Are chemicals or vapors a concern (requiring outside air for combustion or additional ventilation)?

**IMPORTANT:** Fire sprinkler heads must be located at an appropriate distance from the heater. This distance may exceed the published clearances to combustibles as posted on the heater. Certain applications may require the use of high temperature sprinkler heads or relocation of the heaters. Refer to Chart 2.1 on page 7 and NFPA 13.

Sprinkler systems containing propylene glycol or other flammable substances are not to be used in conjunction with this heater without careful consideration for and avoidance of potential fire or explosion hazards. For further information, consult NFPA 13.

The comfort level of a person or space may be diminished with wind velocities above 5 mph. The use of adequate wind barrier(s) may be required (see page 24).

Figure 3.1 • Heater Dimensions

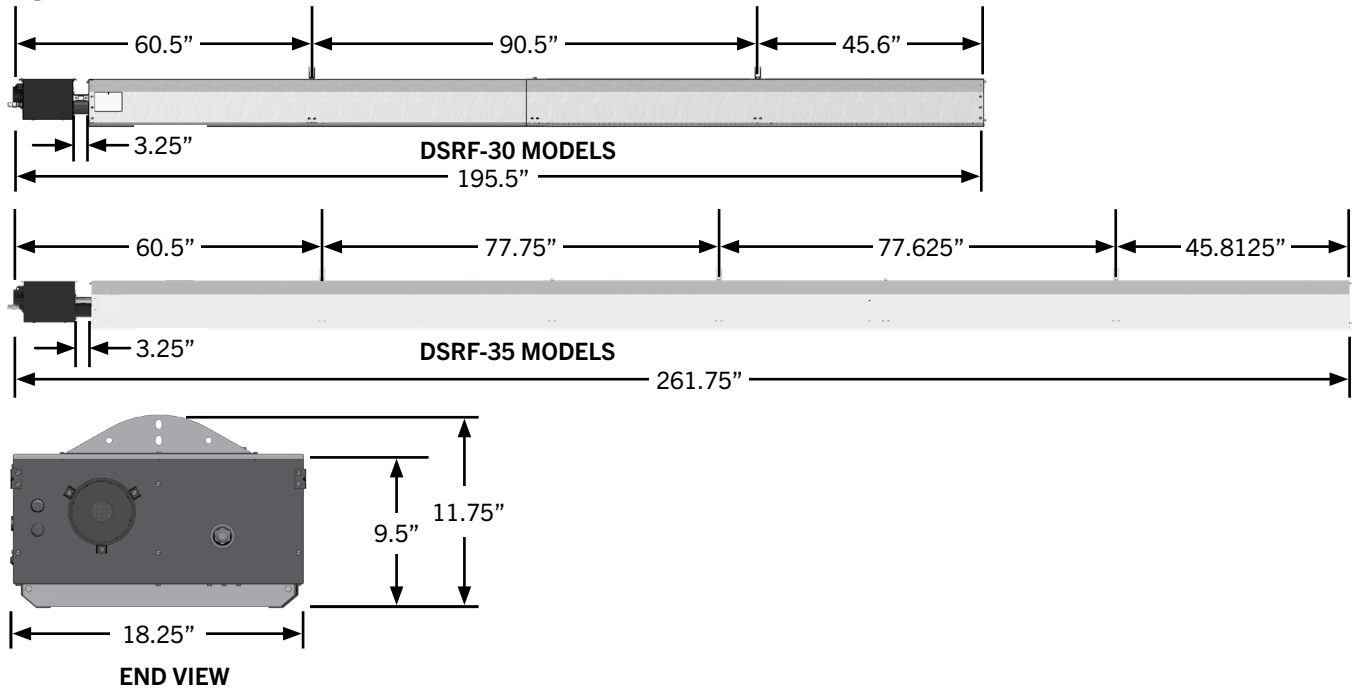
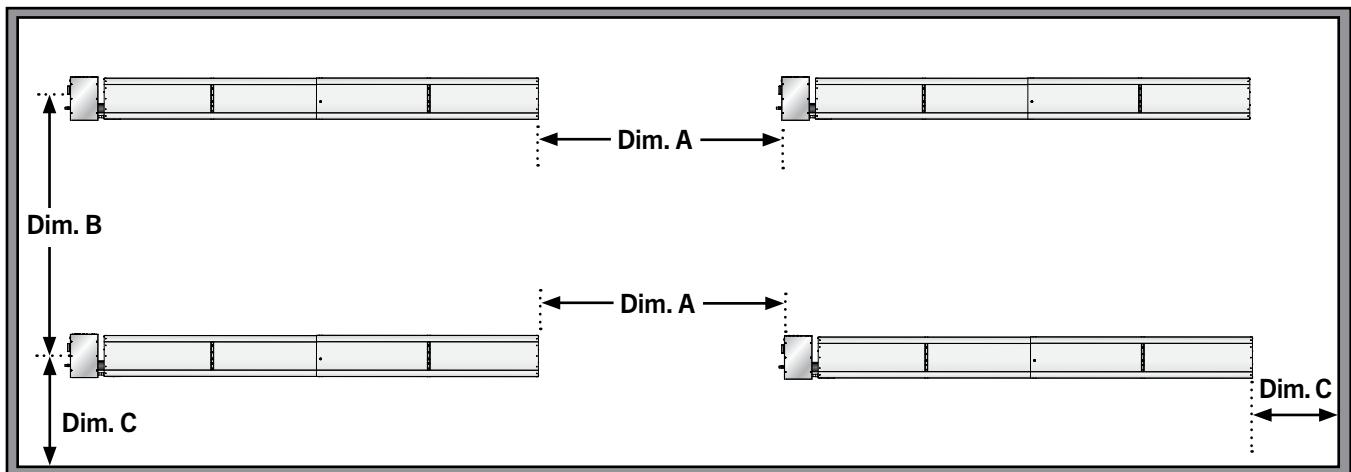


Chart 3.1 • Recommended Mounting Heights and Coverages for DSRF Series Heaters

Max. Input (BTU/h)	Typical or Recommended Mounting Height*	Coverage Area Straight Config. (LxW)	Distance Between Heaters (ft.) Dim. A	Distance Between Heater Rows Dim. B	Max. Distance Between Heaters and Wall - Dim. C
65,000	9' - 16'	26' x 12'	10' - 20'	20' - 40'	16'
80,000	9' - 16'	26' x 12'	10' - 20'	20' - 40'	16'
100,000	9' - 16'	26' x 12'	10' - 20'	20' - 40'	16'

\* Factory recommended mounting heights are listed as a guideline. If infrared heaters are mounted too low or too high, they may result in discomfort due to excessive heat or lack of heat. Detroit Radiant Products Company generally recommends observing the recommended mounting heights to optimize comfort conditions. However, certain applications such as spot heating, freeze protection, outdoor patio heating or very high ceilings may result in the heaters being mounted outside of the factory recommended mounting heights.

Figure 3.2 • Mounting Height Dimensions (see Chart 3.1 for dimensions)



NOTE: Dimensions A, B, & C are based upon heaters hung at the factory recommended mounting height.

## Heater Assembly Instructions

### ⚠ WARNING



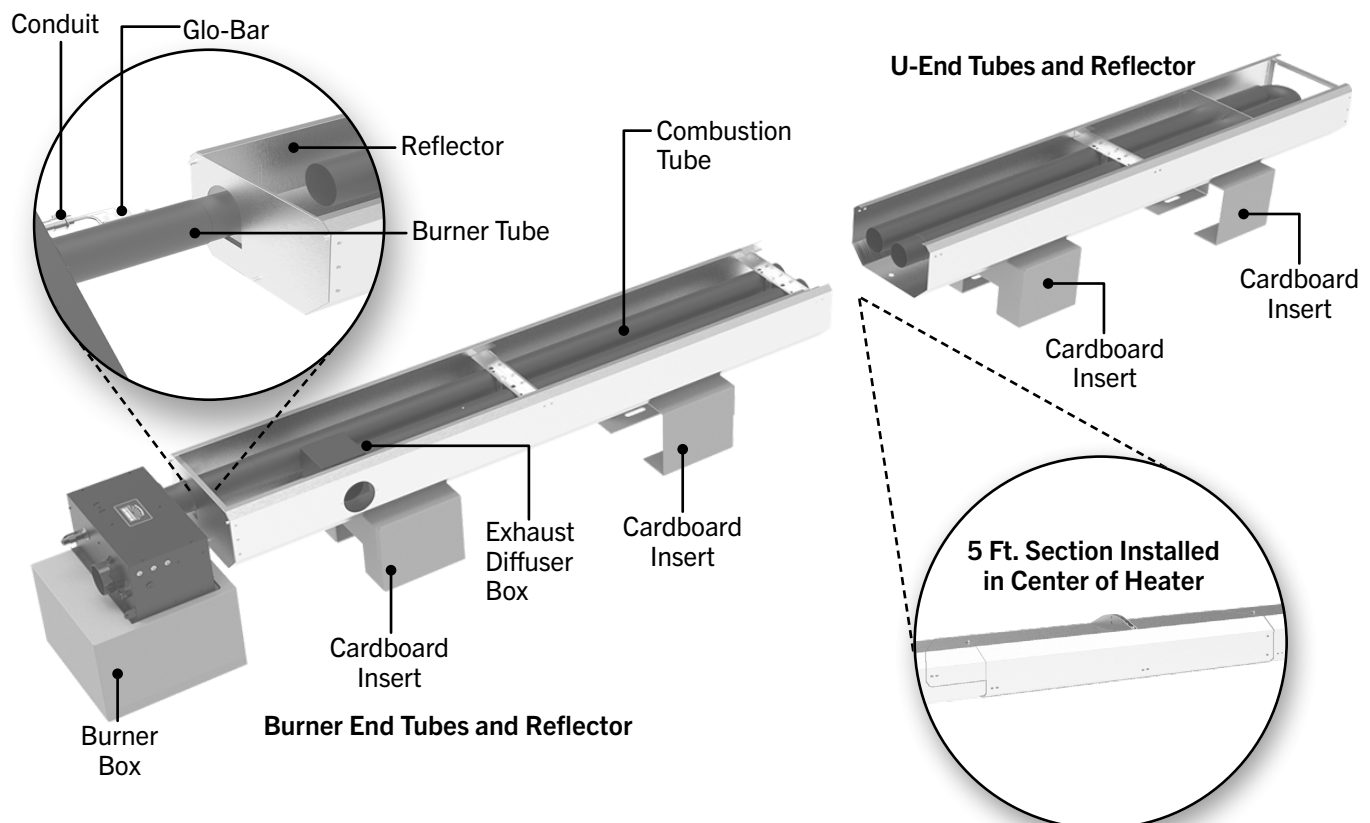
At least two people are required to assemble and hang this heater. Failure to follow these instructions can result in property damage, serious injury, or death.

Read and understand the installation, operation, and maintenance instructions thoroughly before installing or servicing this equipment.

Only trained, qualified gas installation and service personnel may install or service this equipment.

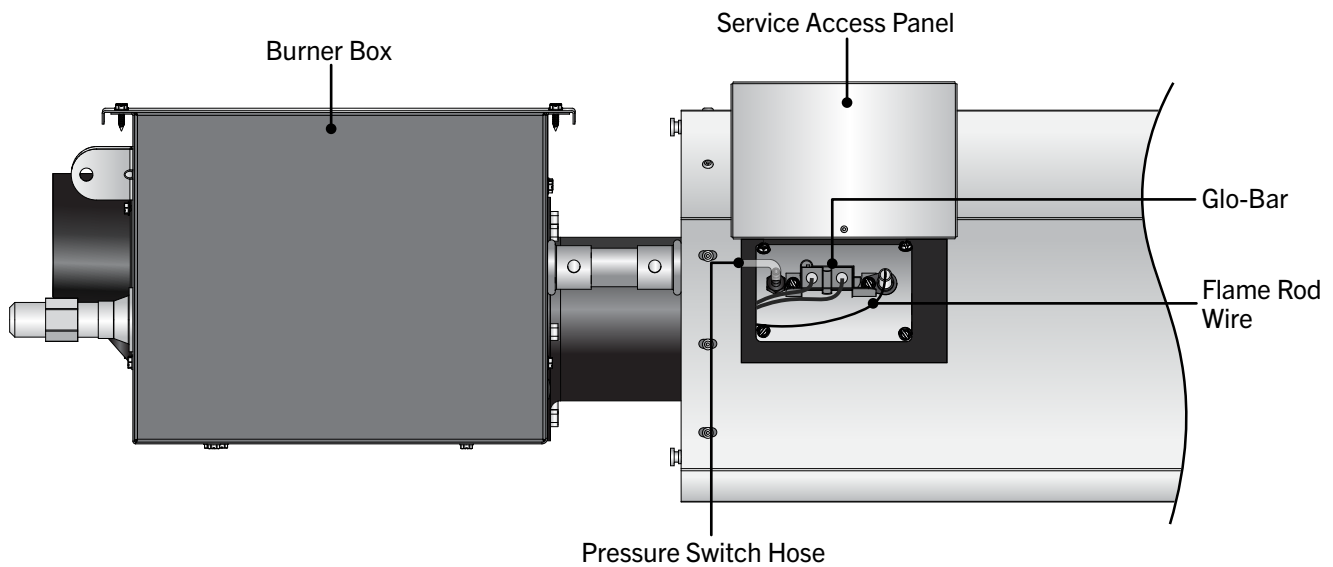
- 1 Remove the burner end and U-end tube and reflector assemblies from the main box and place end-to-end in assembly area. Remove the cardboard inserts from each assembly and rotate 180°. Position each tube and reflector assembly on top of the cardboard inserts with the “U” end on the outside and tubes facing upward (see Fig. 3.3).
- 2 Align both tube and reflector assemblies, then carefully slide the assemblies together, guiding the radiant tubes into one another. **Note:** If you are installing a DSRF-35 model heater, the additional 5 ft. section will be installed in the center of the heater between the burner end and “U” end. For a DSRF-30, the U-end reflector will slightly overlap the burner end reflector. For a DSRF-35, the 5 ft. section will overlap the burner end reflector, and the U-end reflector will overlap the 5 ft. section. The tube and reflector assemblies are in the correct position when the reflector screw holes are aligned (see Fig. 3.7 on page 14).
- 3 Using the #10 screws provided in kit contents box and a 5/16” nut driver, secure the reflectors together so that the screws are hand tight. **Do not** overtighten as this will prevent the expansion and contraction of the reflectors.

Figure 3.3 • Assembly Layout



- 4 Open the burner carton, remove the burner box, and place the kit contents box at the end of the burner end tube and reflector assembly.
- 5 Disconnect the pressure switch hose, Glo-Bar connector, and flame rod wire from their respective connections on the burner tube. Remove the conduit nut from the end of the conduit and set aside. Holding the burner box on its side so as to keep the Glo-Bar clear, place the burner tube through the reflector, lining the swaged end up with the combustion tube (see Fig. 3.3). Rotate the burner box flat so the lid is facing downward. Carefully slide the burner tube into the combustion tube, and feed the conduit, hose, and wires through the conduit hole in the reflector. Slide the hose and wire through the conduit nut, then screw it onto the conduit and securely fasten.

Figure 3.4 • Service Access Panel Connections



- 6 Rotate the service access panel up so the Glo-Bar compartment is accessible. Reconnect the Glo-Bar, pressure switch hose, and flame rod wire, leaving the Glo-Bar connector just outside of the conduit (see Fig. 3.4). Carefully rotate the service access panel back to its closed position.
- 7 Ensure that the swaged end of the burner tube is completely inserted into the combustion tube, then secure with one (1) #10 self-drilling screw (included) where the two tubes overlap (see Fig. 3.7).

Figure 3.5 • Baffle Placement

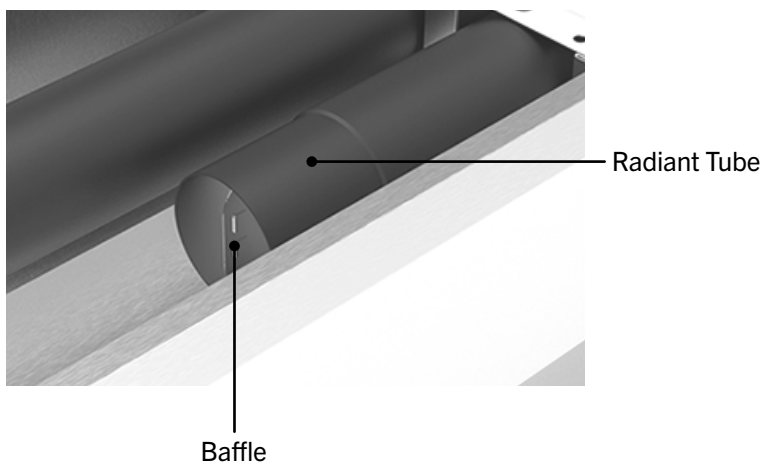
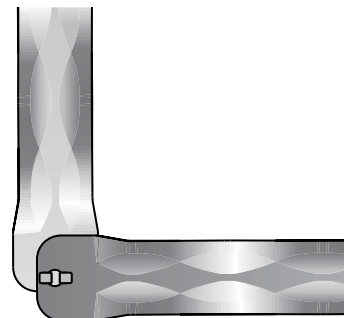
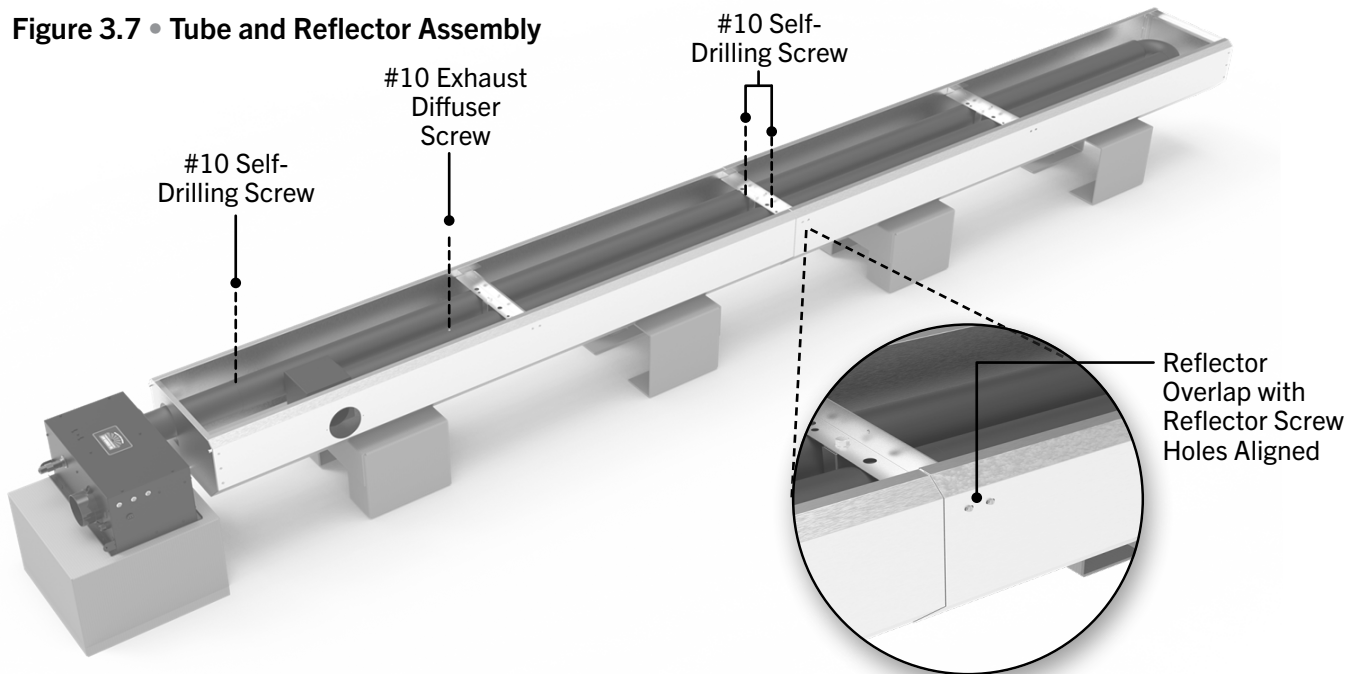


Figure 3.6 • Baffle Assembly



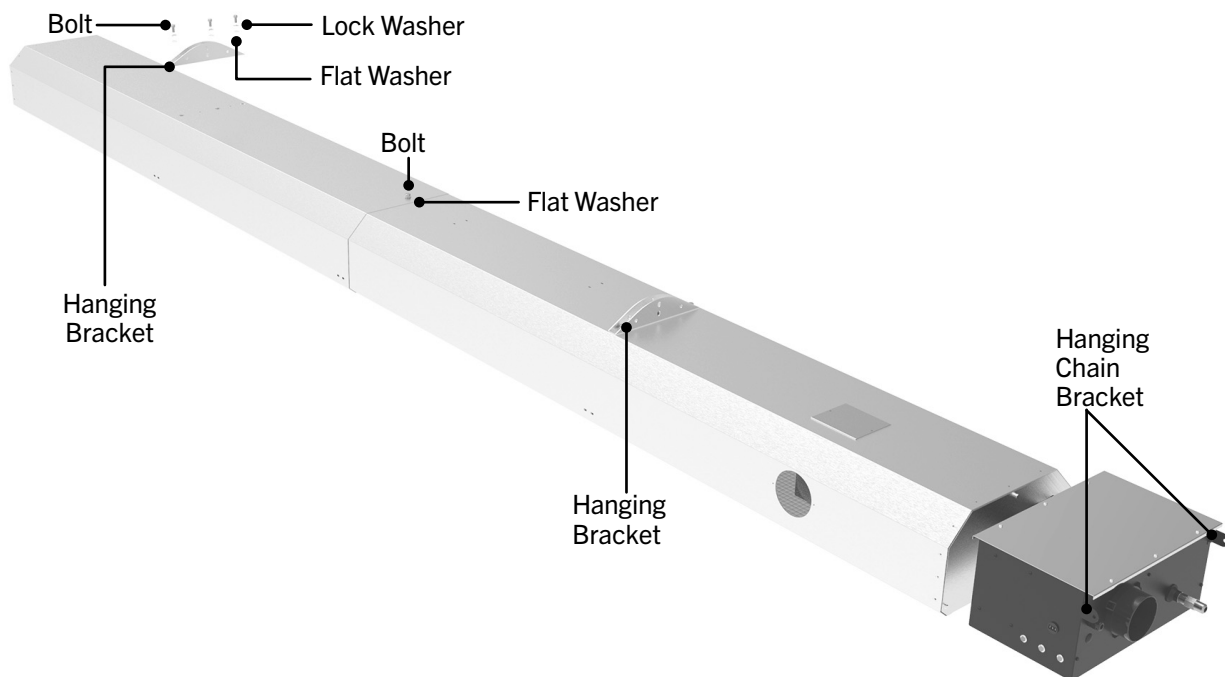
- 8 Remove the existing #10 screw holding the exhaust diffuser box and set aside (see Fig. 3.7). Insert the baffle into the exhaust tube, locking each baffle together as they are inserted. Once in the tube, ensure the baffles are in the vertical position and flush with the end of the tube as shown in Fig. 3.5. Reattach the exhaust diffuser box and secure with the original #10 sheet metal screw.

Figure 3.7 • Tube and Reflector Assembly



- 9 Secure the radiant tube sections together with one (1) #10 self-drilling screw (included) in each, inserting where the tubes overlap (see Fig. 3.7).
- 10 With one person positioned at each end of the heater, carefully flip the unit over and set back down onto the cartons. Using the supplied bolts, lock washer, and flat washer, attach the hanging brackets to the top of the unit as shown in Fig. 3.8.
- 11 Insert the bolt, lock washer, and flat washer in the nutsert in the middle of the assembly and secure (see Fig. 3.8).

Figure 3.8 • Mounting Bracket Placement



## Heater Placement and Suspension

### ⚠ WARNING



Improper suspension of the tube heater may result in collapse and being crushed. Always suspend from a permanent part of the building structure that can evenly support the total force and weight of the heater.

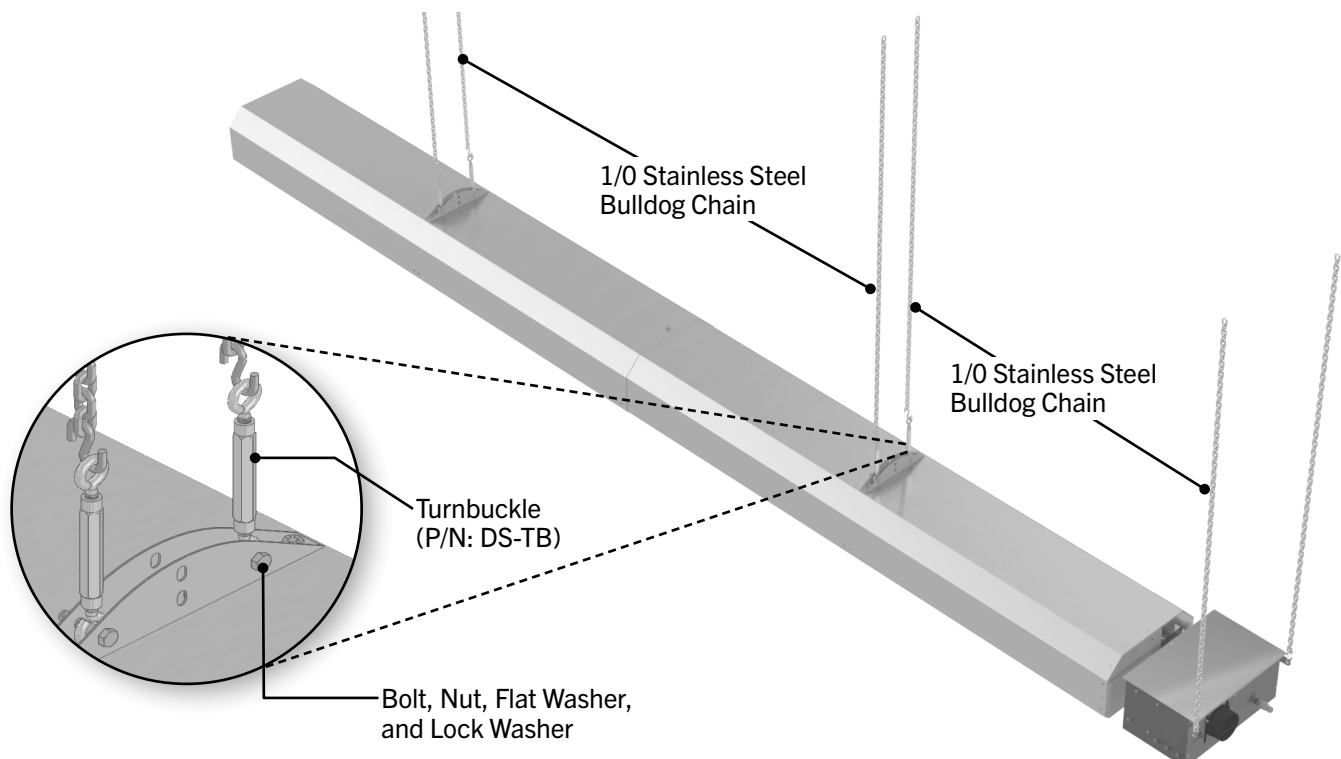


Failure to maintain minimum clearances to combustibles may result in fire and/or explosion, property damage, serious injury, or death. Always maintain minimum clearances and post clearance safety limit signs or the clearance safety tag where needed.

Suspension of the heater must conform to applicable codes referenced in the Safety section and these instructions.

- ① Mark locations for hanging points.
- ② Prepare mounting surface. If necessary, weld blocks and drill holes.
- ③ Fasten beam clamp, screw hook, or other type of suspension anchor to hanging point.
- ④ Attach and close stainless steel S-hook and 1/0 stainless steel bulldog chain to anchor (see Fig. 3.9). Check that it is securely attached. **NOTE:** Threaded rod or optional hanging bracket kit may be used.
- ⑤ Attach stainless steel S-hooks to turnbuckles (P/N: DS-TB sold separately) and hanging bolts inserted through the hanging brackets. Adjust chain lengths until heater is level and equal weight distribution is achieved.
- ⑥ Once heater is level, insert egg crate assemblies by sliding in the reflector, 2 from each end (see Fig. 3.11 on page 17).
- ⑦ Follow instructions on page 17 to install end panels.

Figure 3.9 • Mounting the Heaters



## Sway Bracing for High Air Movement and Outdoor Applications

For high air movement and outdoor applications, install side restraints (field supplied) to reduce side to side swaying as shown in Fig. 3.10. Side restraints should be installed so that they are angled at  $45^\circ \pm 10^\circ$  and should be placed at every designated suspension point. It may be necessary to add additional support structures at the ceiling level for the connection of these side suspensions. Apply longitudinal (forward/backward) bracing (P/N: THGH10-3 or field supplied) at each reflector hanging bracket. The desired suspension material shall have a minimum work load rating of 250 pounds.

**Figure 3.10 • Heater with Sway Bracing Installation**

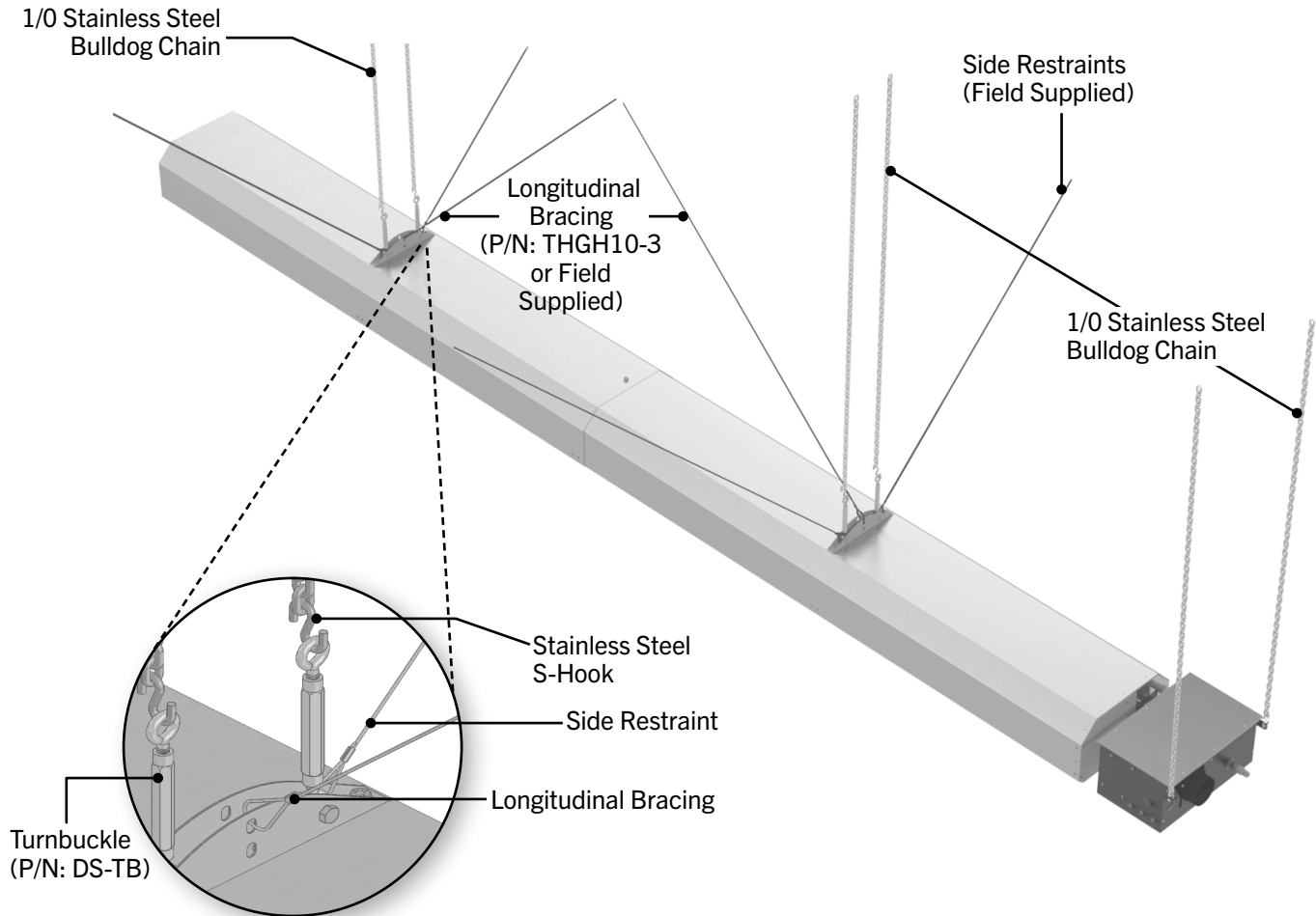
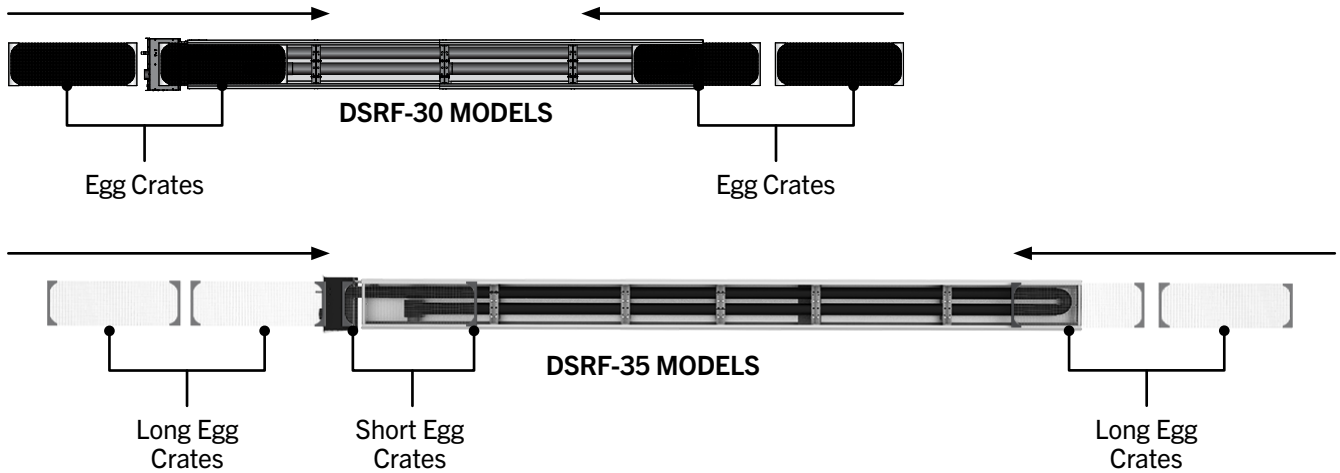


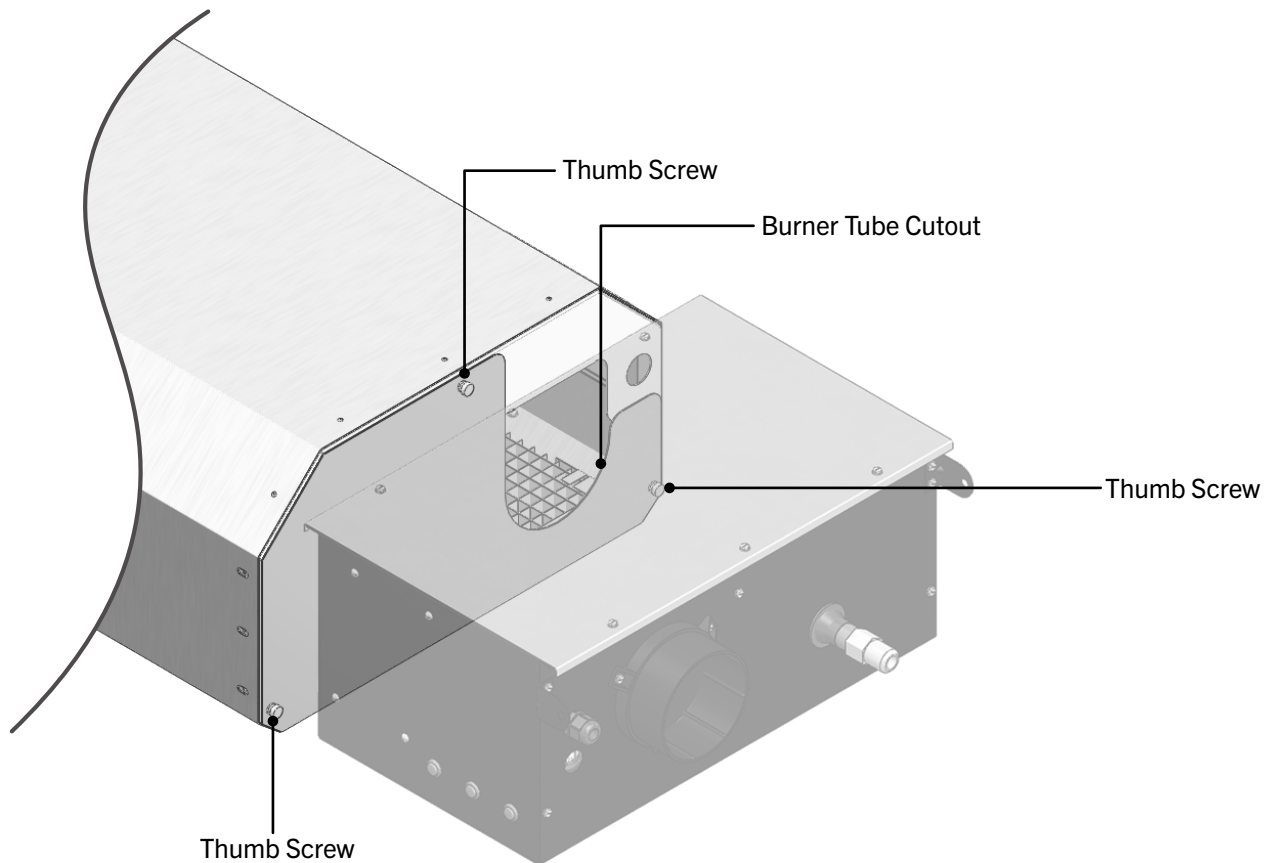
Figure 3.11 • Egg Crate Installation



## End Panel Installation

- 1 Once egg crates are installed, place the reflector end panel flush on the end of the reflector, ensuring edges and screw holes are aligned. Secure with three (3) thumb screws (see Figure 3.12).
- 2 Repeat process with the U-end reflector end panel.

Figure 3.12 • End Panel Installation



## Venting

The DSRF series tube heater must be vented as described here to properly direct flue gases from the unit to the outside atmosphere. The venting can terminate vertically through the roof (up) or horizontally through a sidewall (sideways).

Follow these guidelines and all applicable codes for all models prior to installing the vent material. Local codes may vary.

In the absence of local codes:

**United States:** Refer to NFPA 54/ANSI Z223.1 (latest edition), National Fuel Gas Code.

**Canada:** Refer to CAN/CGA B149.1 and B149.2 Installation Codes for Gas Burning Appliances.

### ! WARNING



Gas-fired heaters must be vented. A built in power exhaustor is provided. Additional external power exhaustors are not required or permitted.

Insufficient ventilation and/or improperly sealed vents may release gas into the building which could result in health problems, carbon monoxide poisoning, or death. Improper venting may result in fire, explosion, injury, or death.

### ! WARNING

**Do not** vent this appliance into another heater's vents or through a masonry chimney.

**Do not** use dampers in the heater vent pipe.

Single wall vent pipe must not pass through any unoccupied attic, inside wall, concealed space, or floor.

Un-insulated single wall vent pipe must not be used outdoors for venting appliances in regions where winter design temperature is below freezing.

## Replacing Existing Equipment

If the heater is replacing existing equipment and using an existing vent system, inspect the venting for proper size and horizontal pitch as directed in these instructions and the latest edition of the National Fuel Gas Code, ANSI Z223.1 (NFPA 54) or CSA B149.1 Installation Code. When an existing Category I heater is removed or replaced, the original venting system may no longer be sized to properly vent the attached appliances.

Determine that there is no blockage or restriction, leakage, corrosion, or other deficiencies that can cause hazards. The vent pipe should be corrosion-resistant galvanized steel of a thickness that meets the National Fuel Gas Code. Minimum thickness for connectors varies depending on the pipe diameter. Never vent the DSRF series with PVC or plastic pipe.

### ! WARNING



If replacing an existing heater, vents may require re-sizing. Improperly sized venting systems can result in vent gas leakage or condensation. Refer to the National Fuel Gas Code ANSI Z223.1 (NFPA 54) or CSA B149.1 - latest edition. Failure to follow these instructions can result in serious injury or death.

## General Venting Requirements

---

The venting system for DSRF series heaters may terminate horizontally through a sidewall or vertically through the roof, and may be individually or commonly vented. Configuration of the vent termination determines the category type. All model heaters must be installed in accordance with the requirements of this section, as well as the requirements of its category determination, as described in this manual. To determine your applications category type, review “Vertical Venting (Category I)” and “Horizontal Venting (Category III)” sections of this manual.

### DSRF Series Model Requirements:

- Exhaust vent pipe must be 4 inch nominal size.
- Use vent pipe material that is corrosion-resistant galvanized steel of a thickness that meets the National Fuel Gas Code.
- Do not exceed a maximum vent length of 20 ft. with two elbows, 25 ft. with one elbow, or 30 ft. with no elbows.
- Maintain a minimum vent length of 3 feet.
- Maintain a minimum of 12 inches of straight pipe from the flue outlet before any directional changes are made in the venting system.
- Have all vent pipe seams or connectors sealed with high temperature silicone sealant approved for at least 550°F (field supplied) and fastened together with at least three (3) corrosion resistant sheet metal screws (field supplied).
- Maintain a 6 inch clearance around all single wall vent pipe from any combustible materials. For double-wall type B vent or Duravent PVP venting, follow the vent manufacturer’s clearances to combustibles.
- The equivalent length for a 4 inch 90° elbow is 5 feet.
- Avoid using more than two 90° directional changes in the venting system.
- Suspend and secure all horizontal runs in a manner consistent with local codes and in such a way that the vent system is supported to prevent sagging.
- Vent termination must maintain a minimum distance of 6 feet from any mechanical air supply inlet.
- The vent terminal must be installed to prevent any blockage by snow and protect building material from degradation by flue gases.
- Consult NFPA ANSI Z223.1 Gas Vent Termination criteria for vents that terminate on a roof pitch that exceeds 9:12.
- **Canada:** Vents must terminate a minimum of 3 feet from a window or door that may be opened, and a non-mechanical air supply inlet or combustion air inlet into the building.

When possible, avoid venting through an unconditioned space. Venting through an unconditioned space promotes condensation. When venting through an unconditioned space is unavoidable, or if the unit is installed in an area that is prone to condensation, insulate venting runs greater than 5 feet to minimize the production of condensation. Inspect for leakage prior to insulating the venting and only use insulation that is non-combustible with a temperature rating of not less than 550°F. Install a tee fitting at the low point of the vent system and provide a drip leg with a clean out cap as shown in Figure 3.13.

When venting pipe passes through a combustible interior wall or floor, a metal thimble with a diameter 4 inches greater than the vent pipe diameter must be used. If there is 6 feet or more of vent pipe prior to passing through the combustible wall or floor, then the metal thimble need only be 2 inches greater than the vent pipe diameter. If a metal thimble is not used, all clearances to combustibles from the vent pipe must be 6 inches. When permitted, type B vent or Duravent PVP venting may be used for the last section of vent pipe to reduce the required clearances to combustibles when passing through a combustible wall or floor. When using type B vent or Duravent PVP venting, follow the manufacturer's recommended clearances to combustibles. Any material used to close or insulate the opening must be non-combustible.

## **Vertical Venting (Category I)**

An appliance that operates with a non-positive vent static pressure and with a vent gas temperature that avoids excessive condensate production in the vent is said to be 'Category I'. The DSRF series heater is considered a Category I appliance if the venting system meets all of the following criteria:

- The vent system terminates vertically (up).
- The length of the horizontal portion of the vent run is less than 75% of the vertical rise length. (e.g.- If the vertical vent height is 10 feet, the horizontal run is less than 7 ½ feet).
- The vent terminates a minimum of 5 feet above the vent connection on the unit.
- Horizontal venting sections of the vent pipe must be installed with an upward slope from the appliance at a pitch of ¼ inch per foot.

For vertical vent termination, the venting must comply with all parts of this section, in addition to the requirements of the general venting.

Category I (Vertical) venting is venting at a non-positive pressure. An appliance vented as a Category I is considered a fan-assisted appliance and the vent system does not have to be 'gas tight'. It is recommended that the venting system is installed with a tee, drip leg, and clean-out cap as shown in Figure 3.13.

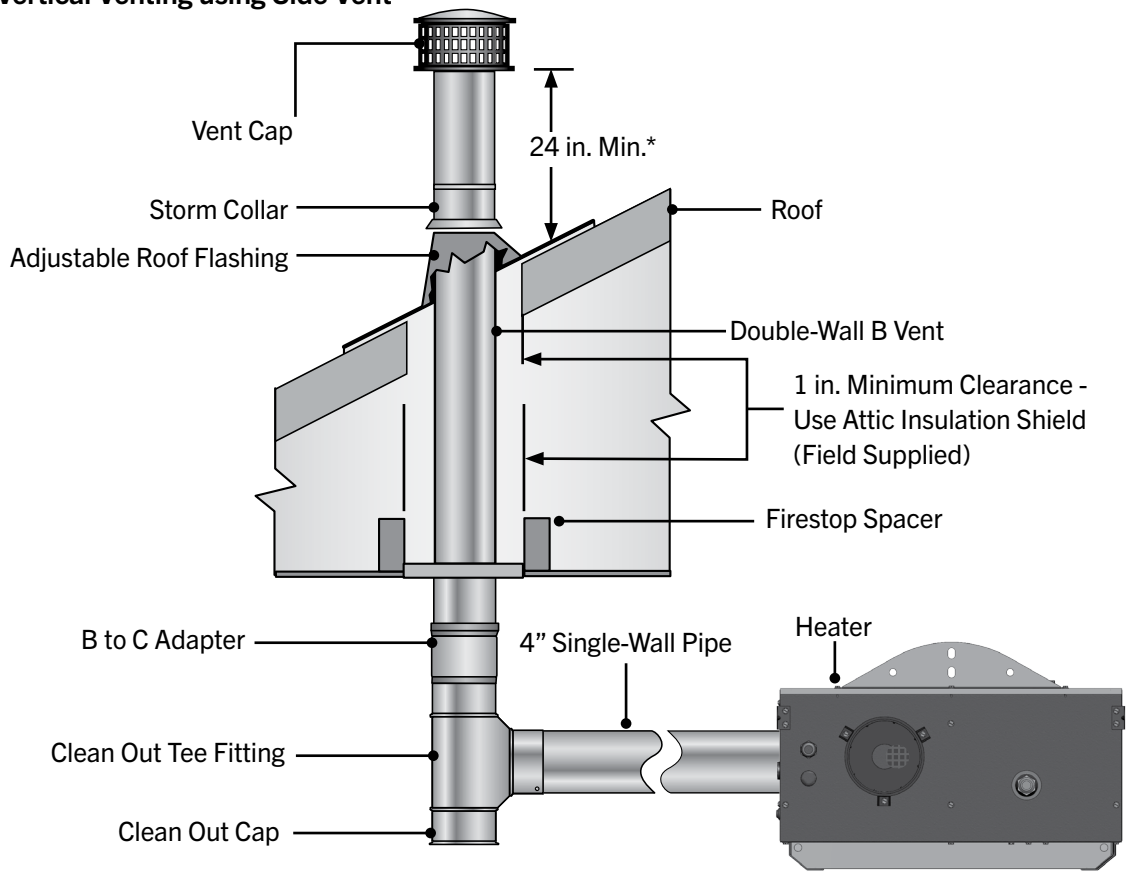
### **Vent Locations and Clearances:**

- Separate air intake duct from vent pipe by a minimum of 4 feet by placing vent pipes higher than adjacent air intake ducts.
- Utilize a listed type B vent termination cap.
- The vent terminal must extend a minimum of 2 feet above the roof.
- Vent caps should be located a minimum of 2 feet away from adjoining structures.

All vertically vented heaters that are Category I must be connected to a chimney or vent complying with a recognized standard, or lined masonry (or concrete) chimney with a material acceptable to the authority having jurisdiction. Venting into an unlined masonry chimney is not permitted. Refer to the National Fuel Gas Code and page 19 of this manual.

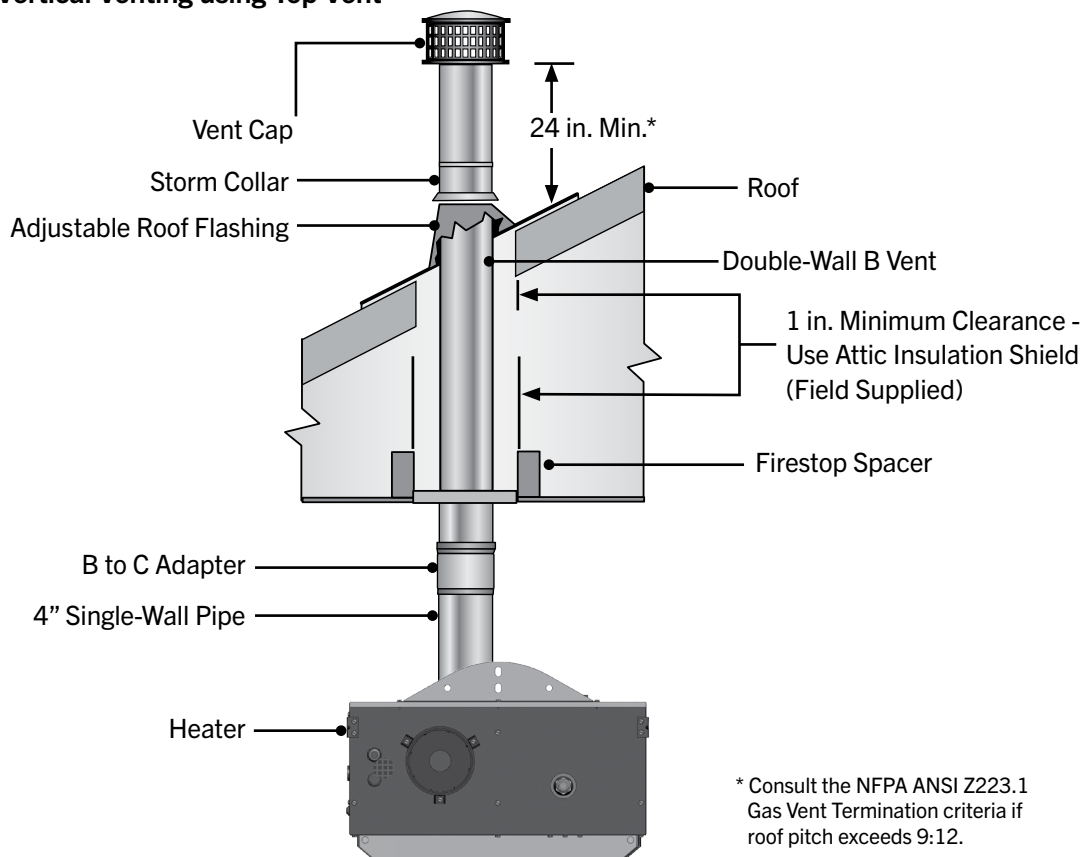
Use a listed vent terminal to reduce down drafts and moisture in the vent.

Figure 3.13 • Vertical Venting using Side Vent



\*Consult the NFPA ANSI Z223.1 Gas Vent Termination criteria if roof pitch exceeds 9:12.

Figure 3.14 • Vertical Venting using Top Vent



\* Consult the NFPA ANSI Z223.1 Gas Vent Termination criteria if roof pitch exceeds 9:12.

## Horizontal Venting (Category III)

---

An appliance that operates with a positive vent static pressure and with a vent gas temperature that avoids excessive condensate production in the vent is said to be “Category III”. The DSRF series heater is considered a Category III appliance if the venting system meets all of the following criteria:

- The vent system terminates horizontally (sideways).
- The vent terminates vertically, but the length of the horizontal portion of the vent run exceeds 75% of the vertical rise length. (e.g.- If the vertical vent height is 10 feet, the horizontal run is greater than 7 ½ feet).
- The vent terminates below 5 feet of the vent connection on the unit.
- Horizontal venting sections of the vent pipe must be installed with a downward slope from the appliance at a pitch of ¼ inch per foot.

Vent enclosed spaces and buildings according to the guidelines in this manual and applicable national, state, provincial, and local codes.

The venting system must be provided by the installer and should be comprised of single-wall venting materials with a thickness of no less than 26 gauge. All joints must be sealed with a high temperature silicone sealant approved for at least 550°F using a minimum bead of ¼” x ¼”, and fastened with at least three corrosion resistant #8 sheet metal screws evenly spaced.

One continuous section of double-wall B vent or Duravent PVP vent may be used to pass through a combustible wall or barrier, or the installer may continue to use single-wall vent provided a combustible wall thimble is used which provides adequate clearances to combustibles.

All horizontal Category III vents must be terminated with a Simpson-Duravent sidewall vent cap (P/N: SWD-4 for 4” venting).

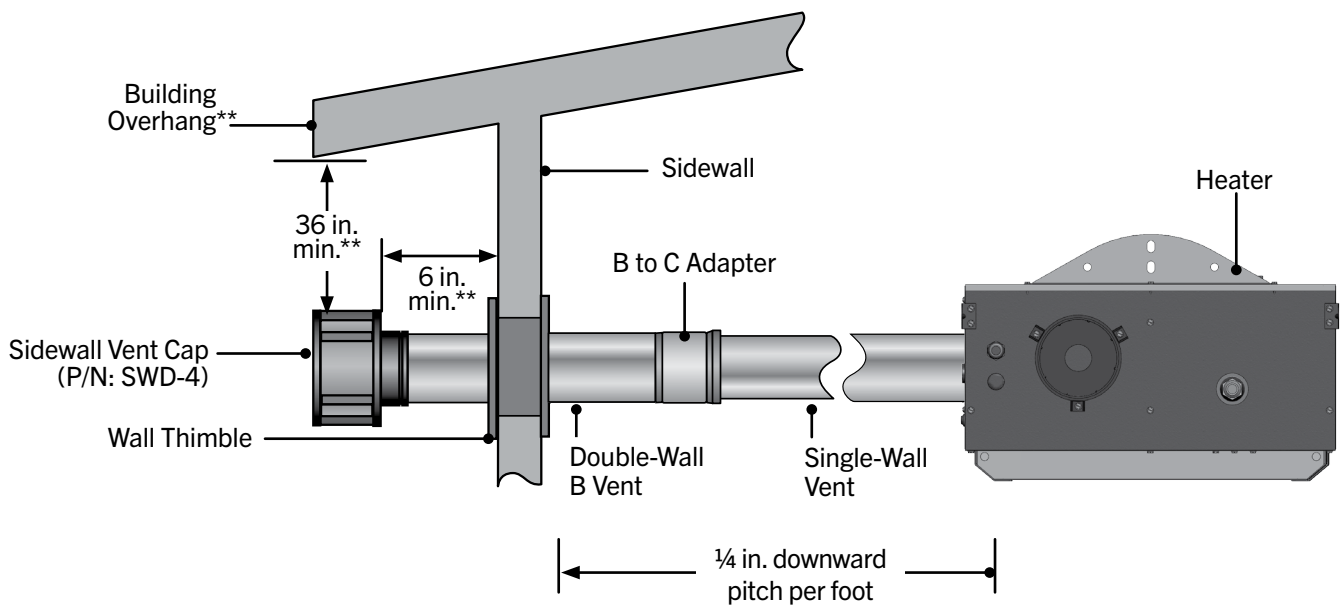
**IMPORTANT!** Once all silicone sealant has fully cured according to manufacturer’s instructions, the installer must perform a leak test on the complete venting system. A solution of soap and water may be used to test the venting inside the occupied space. Once the installer has verified the venting system is completely sealed and free of leaks, the heater may be placed into operation.

**Vent Locations and Clearances:**

- Vent must terminate a minimum of 4 feet below, 4 feet horizontally from, or 1 foot above any window or door that may be opened or gravity air inlet into the building.
- Vent must terminate a minimum of 3 feet above any forced air inlet that is located within 10 feet.
- The bottom of the vent terminate must be located a minimum of 12 inches above grade level and must extend beyond any combustible overhang. Vents adjacent to public walkways must terminate a minimum of 7 feet above grade level.
- The vent cap must be a minimum of 6 inches from the sidewall of the building.
- Vent must be a minimum of 36 inches below or extend beyond any combustible overhang.

Never join two sections of double wall vent pipe within one horizontal vent system as it is impossible to verify that inner pipes are completely sealed.

**Figure 3.15 • Horizontal Venting Requirements**



\*\*Vent must extend beyond any combustible overhang if the vent is less than 36 in. below the combustible overhang.

## Common Venting (Category I)

**Note:** Consult factory prior to common venting. The common vent system and all attached appliances must be Category I and must be on the same control device.

The vent connector should be routed in the most direct route from the units to the common vent.

Where two or more vent connectors enter a common gas vent or chimney flue, the smaller connector shall enter at the highest level consistent with the available head room or clearance to combustible material.

Restrictions within the common vent such as elbows should be minimized. Each elbow installed within the common portion of the vent carrying system reduces the maximum common vent capacity by 10%. Refer to NFPA 54 IFEC tables 11.2 and 11.3 for capacity.

The vent connector capacities allow for the use of two 90° directional changes. For each additional required elbow, the vent connector capacity is reduced by 10%.

The common vent cross sectional area must be equal to or greater than the largest vent connector cross sectional area.

## Unvented Operation

### ⚠ WARNING



**This appliance must be vented in residential installations.** Unvented tube heaters in residential spaces may result in property damage, serious injury, or death. Use unvented operation in commercial and industrial installations with proper ventilation rates only.

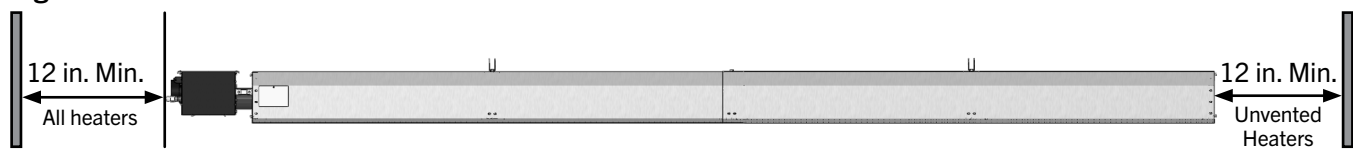
When using an unvented configuration in a commercial/industrial application, consider the following:

- A factory vent cap/diffuser (Kit: DSR-EXH, not included) must be used.
- Where unvented heaters are used, natural or mechanical means must be provided to supply and exhaust a minimum of 4 CFM/1,000 BTU/h input of installed heaters.  
NOTE: Gravity or mechanical means may be used to accomplish the air displacement.

Local codes may require that the mechanical exhaust system be interlocked with the electrical supply line to the heaters, enabling both to function simultaneously.

- The minimum clearance between the air intake and the exhaust terminal is 4 feet.
- Exhaust openings for removing the flue products must be located above the level of the heater(s).

**Figure 3.16 • Minimum End Clearances**



\* Minimum end clearances are 12". However, these distances may be greater when taking into account accessibility of the controls compartment, heat tolerance of adjacent materials such as plastic, and air flow requirements.

## General Combustion Air Requirements

Combustion air may be supplied to the heater by indoor or outdoor means. Follow these guidelines and all applicable codes for all models prior to installing the combustion air duct work. Local codes may vary. In the absence of local codes, refer and comply with the National Fuel Code ANSI Z223.1 (NFPA 54) latest edition.

This unit comes standard equipped for connection of supplied outdoor air for combustion. It is designed for outside air to be brought into the appliance from combustion intake ducts, and is referred to as a “Separated Combustion” appliance.

### WARNING



Sufficient combustion air must be supplied to the appliance at all times. Lack of combustion air may result in property damage, serious injury, or death.

**This heater must operate as a separated combustion system if any of the following criteria apply:**

- Chemicals such as chlorinated or fluorinated hydrocarbons (typical sources are refrigerants, solvents, adhesives, degreasers, paints, paint removers, lubricants, pesticides, etc.) are present in the atmosphere.
- High humidity.
- Contaminants such as sawdust, welding smoke, etc.
- Negative building pressure.
- Unusually tight construction where the air infiltration rate is less than 0.40 air changes per hour.

If your application does not meet any of these criteria, then room air may be used as supplying combustion air to the heater.

Combustion air may be supplied to the heater by indoor or outdoor means.

If using combustion air from indoors, the required volume of the space must be a minimum of 50 ft<sup>3</sup> per 1,000 BTU/h unless the building is of unusually tight construction. If the building is of unusually tight construction with air infiltration rates of less than 0.40 air changes per hour, outside combustion air is typically needed unless the sheer size of the building allows otherwise. Contact the factory for further determination of air infiltration rates.

**Guidelines:****Chart 3.2 • Limitations for Length and Size of Combustion Air Intake Duct**

Single Heater Intake		Dual Heater Intake	
Air Intake Duct Size	Max. Intake Length	Duct Size	Max. Intake Length
4 in.	20 ft.	4 in.(single)/6 in.(dual)	20 ft.
5 in.	30 ft.	4 in.(single)/8 in.(dual)	30 ft.
6 in.	40 ft.	Consult factory for longer intake lengths.	

**General**

- No more than two 90° elbows are allowed.
- Allow for expansion. Use a 4 in. flexible hose to connect the duct to the burner control box.
- In humid environments, use insulated duct, PVC pipe or DWV (drain waste vent) to prevent condensation on the outer surface.
- Do not draw air from attic space.
- A factory approved wall intake cap (P/N: WIV-4) must be used with horizontal outside intake ducts. The wall intake cap (P/N: WIV-4) must be installed to prevent blockage. Locate the intake where dirt, steam, snow, etc. will not contaminate or clog the intake screen.
- Separate air intake duct from vent pipe a minimum of 4 ft. Also, place vent pipe higher than adjacent air intake duct.

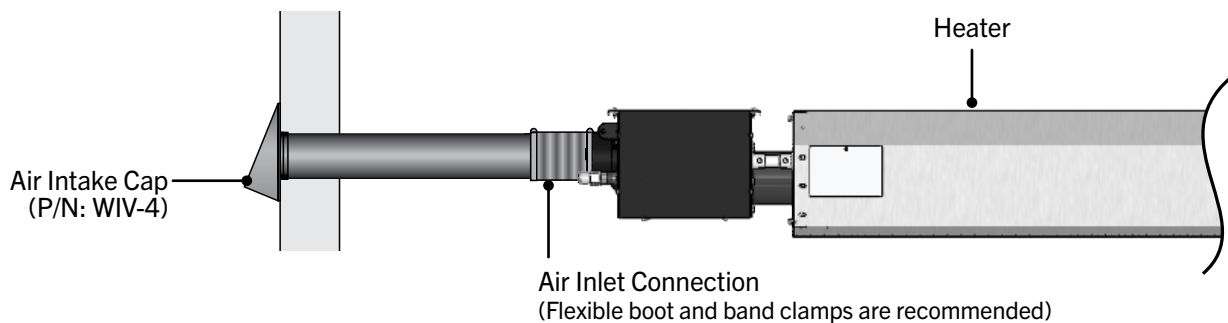
**Figure 3.17 • Air Intake**

Figure 3.18 • Vertical Combustion Air Intake - Side View

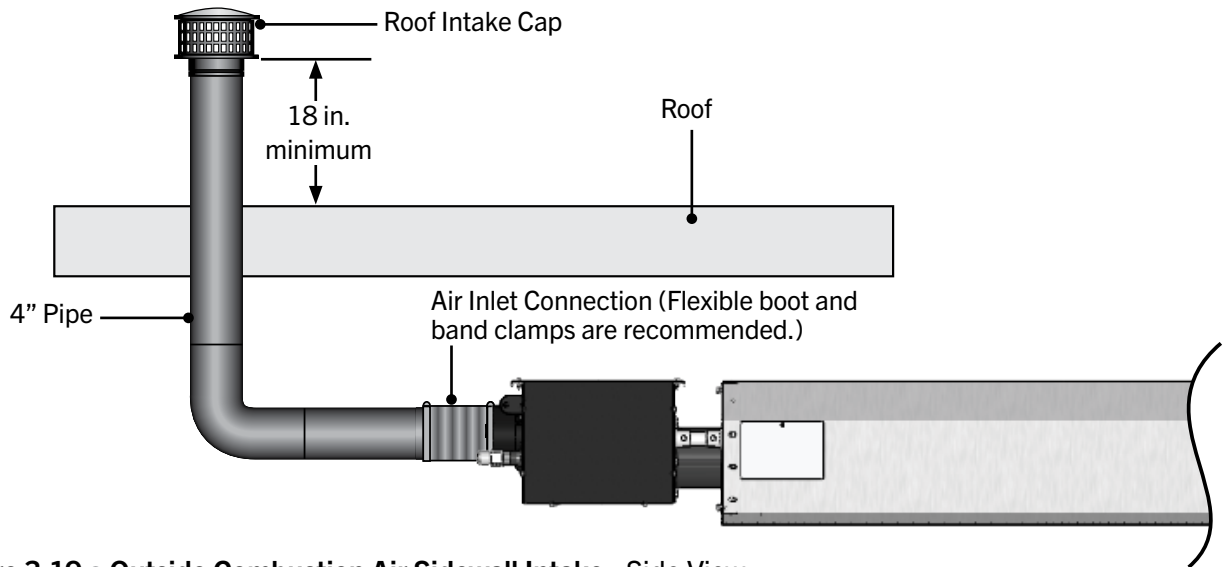


Figure 3.19 • Outside Combustion Air Sidewall Intake - Side View

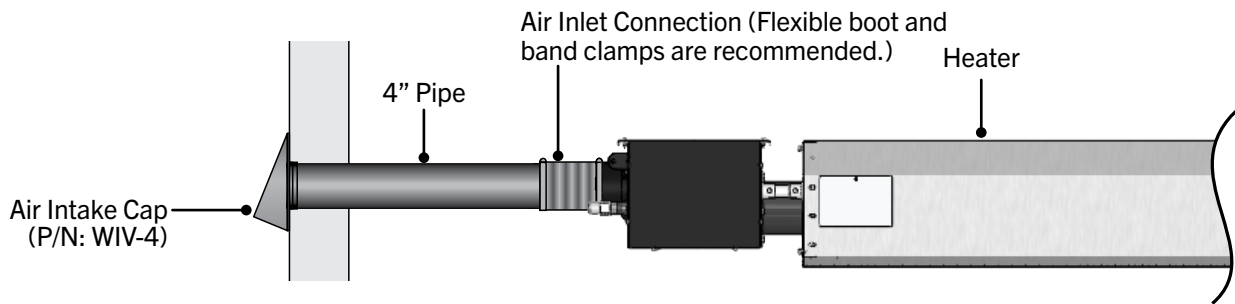
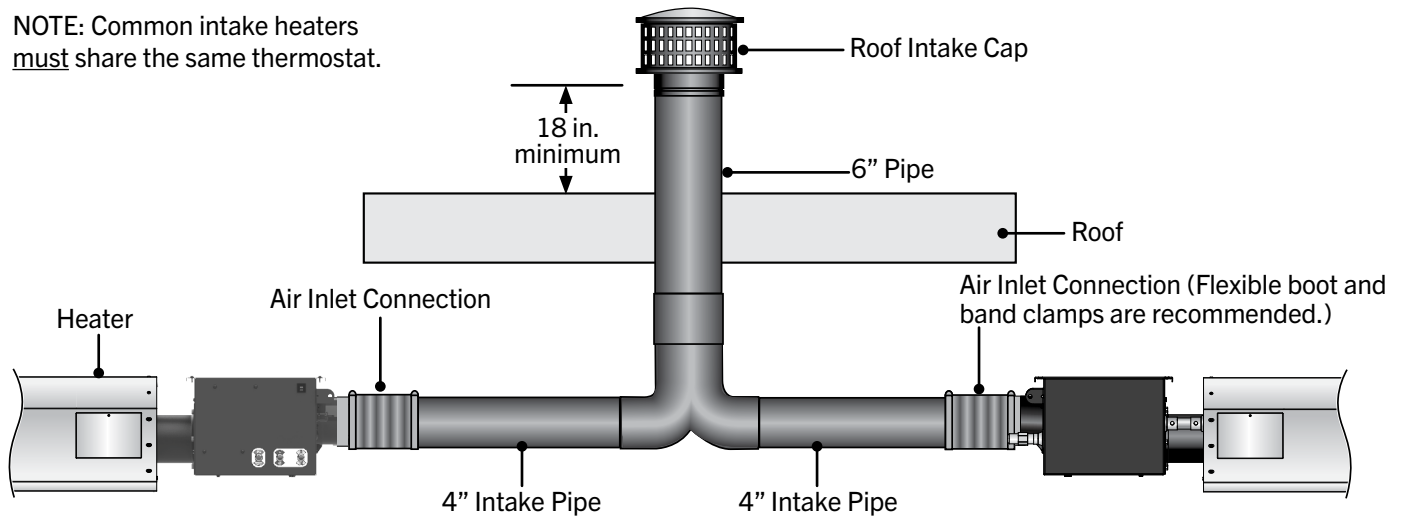


Figure 3.20 • Vertical Outside Air Supply for Common Intake - Side View

NOTE: Common intake heaters must share the same thermostat.



## Gas Supply Installation Instructions

The gas supply to the unit heater must be connected and tested in accordance with national, state, and local codes along with guidelines in this manual. In the United States, refer to the latest edition of the ANSI Z223.1 (NFPA54) Standard. In Canada, refer to the latest edition of CAN/CGA B149.1 and .2.

Supply gas piping to the unit should conform with the local and national requirements for type and volume of gas handled, and pressure drop allowed in the line. Avoid pipe sizes smaller than ½”.

### ⚠ WARNING



Improperly connected gas lines may result in serious injury and death, explosion, poisonous fumes, toxic gases, or asphyxiation. Connect gas lines in accordance to national, state, provincial, and local codes.

Gas pressure to the appliance controls must never exceed ½” PSI (14” W.C.). Damage to the controls may result.

### ⚠ CAUTION

Gas lines should be purged of air as described in ANSI Z223.1 (NFPA 54) or CSA B149.1 (latest version). Installation of the piping must also conform with the local building codes or, in the absence of local codes, with the latest edition of the National Fuel Gas Code (NFPA 54).

### NOTICE

The total input to the appliance must fall within +/- 5% of the rated input as indicated on the rating plate. Otherwise the heat exchanger may prematurely fail.

**IMPORTANT!** Before connecting the gas supply to the burner control box:

- Verify that the heater’s gas type (as listed on the rating plate) matches that of your application and the installation complies with national and local codes and requirements of the local gas company.
- Unless otherwise noted on the rating plate, this infrared heater is designed and orificed to operate on standard BTU gas. Contact the factory if utilizing non-standard BTU gas.
- Check that the gas piping and service has the capacity to handle the total gas consumption of all heaters being installed, as well as any other gas appliances being connected to the supply line.
- Check that the main gas supply line is of proper diameter to supply the required fuel pressures.
- If utilizing used pipe, verify that its condition is clean and comparable to a new pipe. Test all gas supply lines in accordance with local codes.

**To connect the gas:****! WARNING**

Failure to install, operate, or service this appliance in the approved manner may result in property damage, injury, or death. Only trained, qualified gas installation and service personnel may install or service this equipment.

The DSRF Series heater is equipped to connect to the corrugated stainless steel tube (CSST) flexible gas connector (included). **Do not connect the main gas line directly to the heaters gas inlet without the use of the flexible connector.** All piping must be installed in accordance with the requirements outlined in the National Fuel Gas Code ANSI/Z223.1 (latest edition) or CSA B149.1. Support all gas piping with pipe hangers, metal strapping, or other suitable material. Do not rely on the heater to support the gas pipe.

When connecting piping to the unit, the use of a thread joint compound is required. The thread compound (pipe dope) shall be resistant to the action of the type of gas being used or any other chemical constituents of the gas to be conducted through piping. Use of Teflon® tape is not permitted.

**! WARNING**

Always use two (2) opposing wrenches to tighten mating pipe connections to prevent excessive torque on the gas valve and manifold pipe. Excessive torque can damage the valve and/or misalign the orifice, resulting in fire, explosion, serious injury, or death.

Connect the main gas supply line with an approved flexible connector or, if the authority having jurisdiction requires rigid piping, approved swing joints may be used. If swing joints are utilized, the heater must be allowed to freely expand and contract without causing undue stress on the gas pipe.

The heater shall not be connected to the building piping system with rigid pipe or semi-rigid metallic tubing, including copper. When using such material, an intermediate connection device that allows for the heater expansion must be used.

The gas outlet must be in the same room as the appliance is installed, and must be accessible. It may not be concealed within or run through any wall, floor, or partition. When installing the heater in a corrosive environment (or near corrosive substances), use a gas connector suitable for the environment. Do not use the gas piping to electrically ground the heater.

## Installation of the Gas Line to the Heater

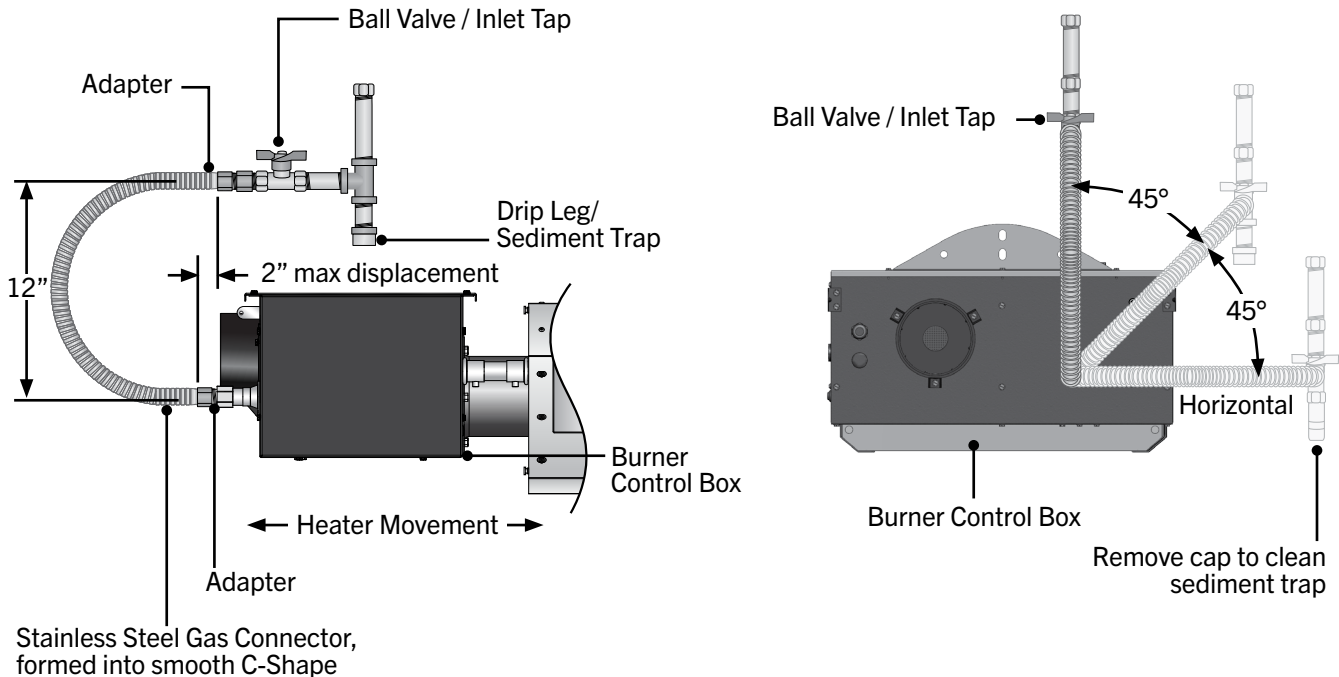
- ❶ Install a sediment trap / drip leg in the supply line at the lowest spot prior to the gas ball valve. The trap length shall be at least three inches long. Ideally, the trap would be installed as close as possible to the shut off. **NOTE:** For high pressure gas above 14" W.C., a high pressure regulator and ball valve must be utilized and located upstream of the flex connector.
- ❷ Install manual shut off ball valve with optional 1/8" NPT. Test connection towards the supply line. The manual shut off ball valve must be located within 6 feet of the appliance's service access door.
- ❸ Install the 5/8" flare to 1/2" NPT adapter piece downstream of the gas valve as shown in Figures 3.21-3.22. This piece is typically included with the flexible gas connector, loosely installed on one of the flare nuts. **NOTE:** Keep flare surfaces clean and free of sealing compounds. Only the pipe threads require sealing compounds.
- ❹ Form the 1/2" x 24" stainless steel flexible gas connector into a smooth C-shape, allowing approximately 12 inches between the flexible connector's end nuts (see Figure 3.21). The connector must reach from the gas supply to the appliance without stretching, kinking, or twisting.
- ❺ Attach the flexible connector to the 5/8" flare adapter on the gas line and the other end to the 5/8" flare on the heaters inlet pipe. **DO NOT** connect the connector flare nuts directly to pipe threads. Use only the adapters provided. **DO NOT** kink, twist, or over-torque the connector when installing.

### ⚠ CAUTION

When using a stainless steel flexible gas connector, **do not** attach the connector nuts directly to the gas pipe supply. Connector nuts must be installed to an approved adapter.

**Figure 3.21 • Gas Connection (Flexible Gas Connection Shown)**

**NOTE:** Do not exceed 14" W.C. to the appliance.



In Canada, the infrared heater shall only be connected with a Type I hose connector that is (a) certified as being in compliance with the *Standard for Elastomeric Composite Hose and Hose Couplings for Conducting Propane and Natural Gas, CAN/CGA 8.1*; and (b) of a length of  $36 \pm 6$  in ( $90 \pm 15$  cm).

Refer to Chart 3.3 for natural gas and Chart 3.4 for propane to determine the cubic feet per hour (CFH) required for the type of gas and size of unit to be installed. To determine the proper pipe diameter, use the CFH value and the length of pipe necessary from Chart 3.5. In the case where several units are serviced by the same main gas line, the total capacity (CFH) and length of main must be adequate to service all appliances downstream of this main.

**Chart 3.3 • Natural Gas Consumption**

Model	Input High/Low	Manifold Pressure (Inches W.C.)	Min. Inlet Pressure (Inches W.C.)	Max. Inlet Pressure (Inches W.C.)	Gas Consumption (CFH)*
DSRF-(30, 35)-65N	65,000 (High)	3.5	5.0	14.0	61.9
	50,000 (Low)	2.2			47.6
DSRF-(30, 35)-80N	80,000 (High)	3.5	5.0	14.0	76.2
	52,000 (Low)	1.7			49.5
DSRF-35-100N	100,000 (High)	3.5	5.0	14.0	95.2
	65,000 (Low)	1.8			61.9

\* Assumes an average heating value of 1050 BTU/SCF and a Specific Gravity of 0.60.

**Chart 3.4 • Propane Gas Consumption**

Model	Input High/Low	Manifold Pressure (Inches W.C.)	Min. Inlet Pressure (Inches W.C.)	Max. Inlet Pressure (Inches W.C.)	Gas Consumption (CFH)*	Gallons p/ Hour
DSRF-(30, 35)-65P	65,000 (High)	10.0	11.0	14.0	26	0.71
	50,000 (Low)	4.8			20	0.54
DSRF-(30, 35)-80P	80,000 (High)	10.0	11.0	14.0	32	0.87
	52,000 (Low)	4.8			21	0.56
DSRF-35-100P	100,000 (High)	10.0	11.0	14.0	40	1.08
	65,000 (Low)	4.8			26	0.71

\* Assumes an average heating value of 2500 BTU/SCF and a Specific Gravity of 1.53.

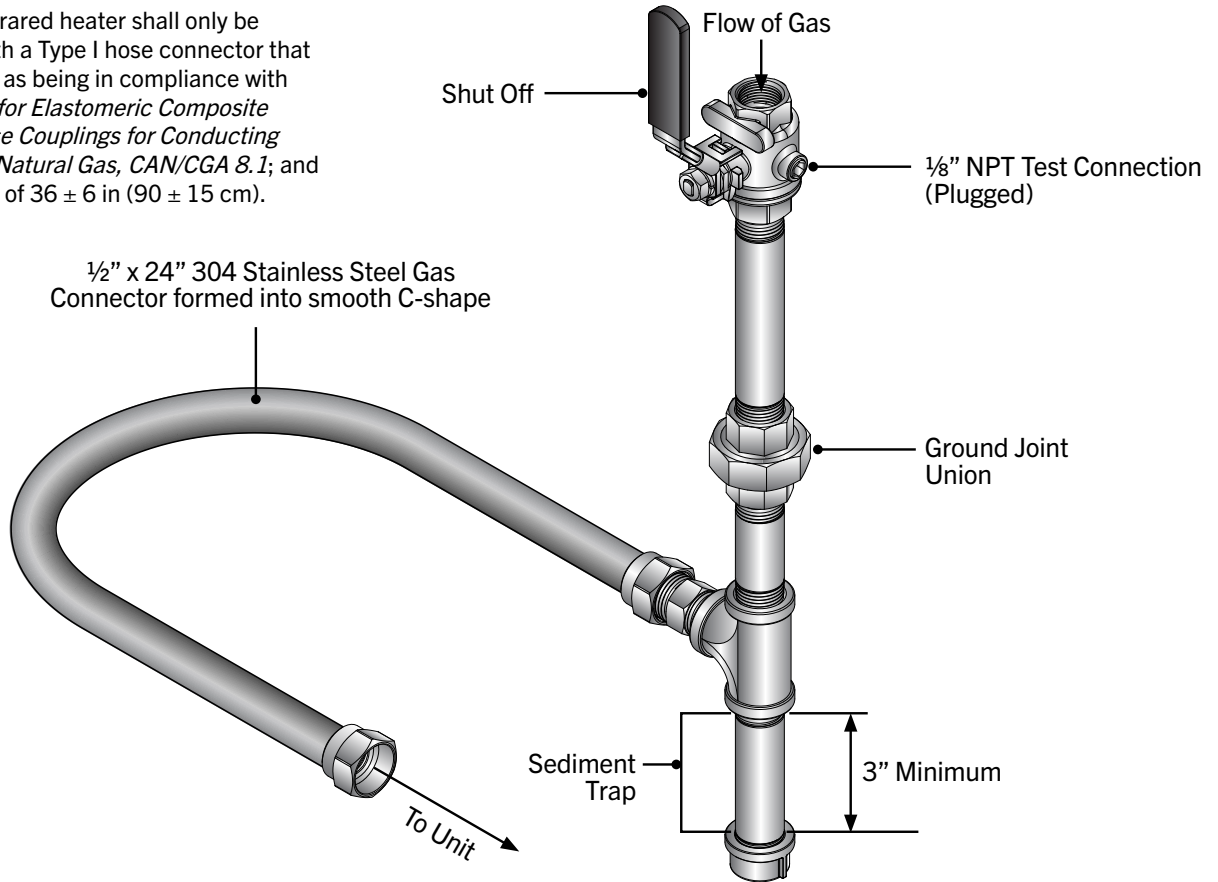
Chart 3.5 allows for a 0.3 inch W.C. pressure drop in the supply pressure from the building main to the inlet of the unit. Refer to the chart for the appropriate range of inlet pressures for each gas type. When sizing the inlet gas pipe diameter, make sure that the unit supply pressure can be met after the 0.3 inch W.C. pressure drop has been subtracted from the main pressure. If the 0.3 inch W.C. pressure drop is too high, refer to NFPA 54 or the Gas Engineer’s Handbook for other gas pipe capacities.

Install ground joint union with a brass seat and a manual shut-off valve adjacent to the unit for emergency shut-off and easy servicing of controls. A 1/8” NPT plugged tap that is accessible for a test gauge connection is also recommended, as illustrated in Figure 3.21.

A sediment trap must be installed in the supply line in the lowest spot prior to connecting to the heater. The trap length shall be at least three inches long. Ideally, the trap would be installed as close as possible to the shut-off, as shown in Figure 3.21.

**Figure 3.22 • Recommended Hardware • Manual Shut Off and Sediment Trap**

In Canada, infrared heater shall only be connected with a Type I hose connector that is (a) certified as being in compliance with the *Standard for Elastomeric Composite Hose and Hose Couplings for Conducting Propane and Natural Gas, CAN/CGA 8.1*; and (b) of a length of 36 ± 6 in (90 ± 15 cm).



**Chart 3.5 • Maximum Capacity for Schedule 40 Metallic pipe, in CFH**

Pipe Length	1/2"		3/4"		1"		1 1/4"		1 1/2"		2"	
	Nat	Prop	Nat	Prop	Nat	Prop	Nat	Prop	Nat	Prop	Nat	Prop
10 feet	132	86	278	182	520	340	1050	686	1600	1046	3050	1993
20 feet	92	60	190	124	350	229	730	477	1100	719	2100	1373
30 feet	73	48	152	99	285	186	590	386	890	582	1650	1078
40 feet	63	41	130	85	245	160	500	327	760	497	1450	948
50 feet	56	37	115	75	215	141	440	288	670	438	1270	830
60 feet	50	33	105	69	195	127	400	261	610	399	1150	752
70 feet	46	30	96	63	180	118	370	242	560	366	1050	686
80 feet	43	28	90	59	170	111	350	229	530	346	990	647
90 feet	40	26	84	55	160	105	320	209	490	320	930	608
100 feet	38	25	79	52	150	98	305	199	460	301	870	569
125 feet	34	22	72	47	130	85	275	180	410	268	780	510
150 feet	31	20	64	42	120	78	250	163	380	248	710	464
175 feet	28	18	59	39	110	72	225	147	350	229	650	425
200 feet	26	17	55	36	100	65	210	137	320	209	610	399

The DSRF Series heater is equipped to receive a gas supply line nipple of 1/2" NPT Schedule 40 metallic pipe. All piping must be installed in accordance with the requirements outlined in the National Fuel Gas Code ANSI/Z223.1 (latest edition) or CSA-B149.1. Support all gas supply piping with pipe hangers, metal strapping, or other suitable material. Do not rely on the heater to support the gas pipe.

When connecting piping to the unit, the use of a thread joint compound is required. The thread compound (pipe dope) shall be resistant to the action of liquefied petroleum gas or any other chemical constituents of the gas to be conducted through the piping. Use of Teflon® tape is not permitted.

## ⚠ WARNING



Always use two (2) opposing wrenches to tighten mating pipe connections to prevent excessive torque on the gas valve and manifold pipe. Excessive torque can damage the valve and/or misalign the orifice, resulting in fire, explosion, serious injury, or death.

## Leak Testing

## ⚠ WARNING



Use a soap solution or equivalent for leak testing. Never test for leak with an open flame. Failure to comply could result in personal injury, property damage, or death.

Always leak test final gas assembly for gas leaks according to the procedures outlined in NFPA 54 and all local codes and/or standards.

### For leak testing on pressures below ½" PSI

Before leak testing, close the field installed manual shut off valve shown on Figure 3.22 on the supply line to isolate the gas valve from the pressure.

**NOTE:** All factory installed gas connections have passed an approved leak test.

### For leak testing on pressures above ½" PSI

When leak testing with pressures above ½" PSI (14" W.C.), the unit must be isolated from the supply pipe. Close the field installed manual shut off valve, disconnect the supply line to the unit, and temporarily cap the supply line for testing purposes.

## ⚠ WARNING



Gas pressures to the appliance controls must never exceed 14" W.C. (½" PSI). Supply pressures greater than 14" W.C. can damage the controls, resulting in personal injury, property damage, or death.

## Electrical Requirements and Wiring Diagrams

### ⚠ WARNING



Shock hazard. Disconnect power supply before making wiring connections to prevent electrical shock and equipment damage.

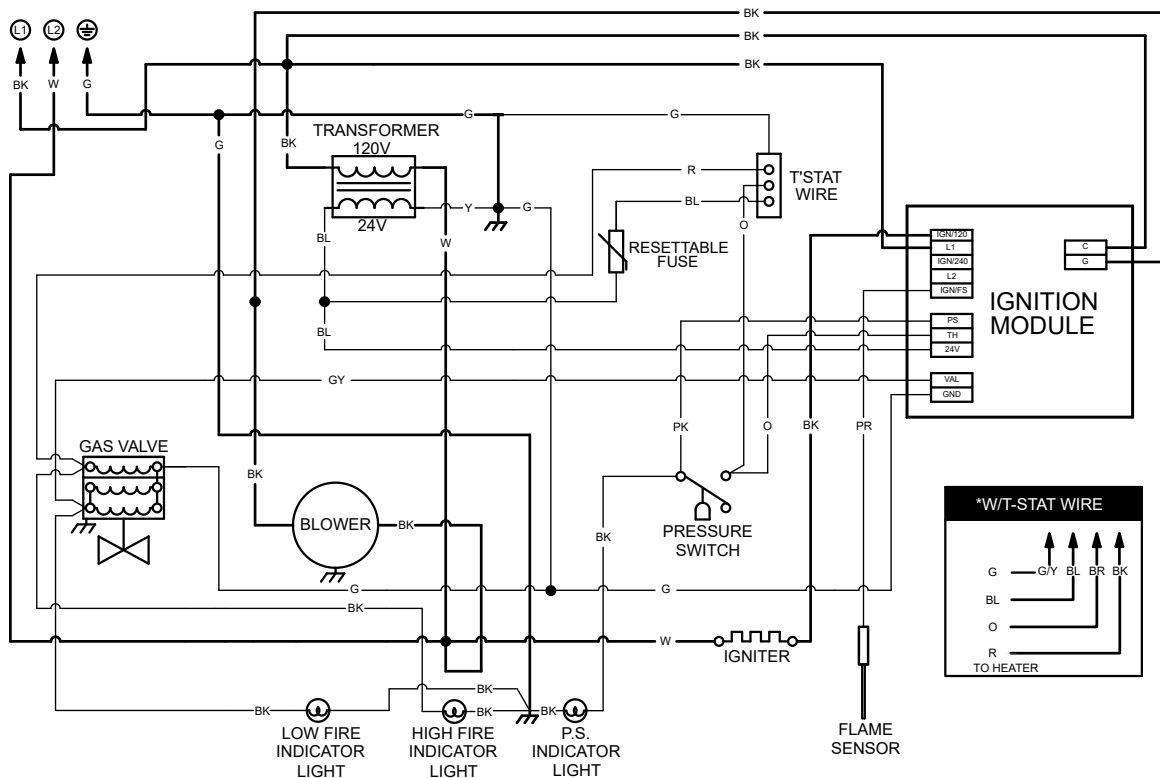
Any original factory wiring that requires replacement must be replaced with wiring material having a temperature rating of at least 105°C minimum voltage.

All field installed wiring to the tube heater must be done in accordance with the national, state, provincial, local codes, and to the guidelines in this manual. In the United States, refer to the most current revisions to the Electrical Code ANSI/NFPA 70. The unit must be electrically grounded according to these codes. Line polarity must be observed when making field connections.

### Internal Wiring Diagram

Before wiring this appliance, check the existing wiring; replace if necessary. If any of the original wire supplied with the appliance must be replaced, it must be replaced with copper wiring material having a rating of at least 300 V, 105°C.

Figure 3.23 • Internal Wiring Diagram



WIRING INFORMATION:

LINE VOLTAGE:

- FACTORY STANDARD \_\_\_\_\_
- FACTORY OPTION - - - - -
- FIELD INSTALLED - - - - -

LOW VOLTAGE:

- FACTORY STANDARD \_\_\_\_\_
- FACTORY OPTION - - - - -
- FIELD INSTALLED - - - - -

**⚠ WARNING**

Incorrect or improper wiring may result in shock, injury, or death. Field wiring to the heater must be connected and grounded in accordance with national, state, provincial, local codes, and to the guidelines in this manual. Refer to the most current revisions to the ANSI/NFPA 70 Standard.

All field wiring to the DSRF Series heater must be done in accordance with the national, state, provincial, local codes, and the guidelines in this manual. In the United States, refer to the most current revisions to the Electrical Code ANSI/NFPA 70. In Canada, refer to CAN/CGA B149.1 and .2. The unit must be electrically grounded according to these codes.

**Field Wiring Supply Voltage**

Before proceeding with electrical connections, ensure that the supply voltage, frequency, phase, and current capacity meet the requirements specified on the rating plate. A dedicated line voltage supply with properly sized wire should run directly from the main electrical panel to the heater. The power to the unit must be protected with a circuit breaker appropriate for the load. The unit must be electrically grounded in accordance with local codes or, in their absence, with the latest edition of the National Electrical Code, ANSI / NFPA 70 and/or the Canadian Electrical Code CSA C22.1 (latest edition).

**⚠ CAUTION**

The power supply to the heater must be within +/- 5% of the voltage rating as indicated on the rating plate of the appliance. If input power does not meet these specifications, contact your utility company.

The heater comes equipped with a supply cord to connect the main power supply. It is located at the rear of the heater's burner box and utilizes a grounding prong. This plug must be connected into an appropriate outlet receptacle that is properly installed and grounded in accordance to local codes and ordinances.

The grounding receptacle must be installed within 5 feet of the heater's service panel and located in the space occupied by the appliance. When plugging in the heater, make sure the supply cord is protected from damage and keep all cords away from the heater's surfaces and out of the clearances to combustibles zone (see page 9). When routing the electrical supply for the unit, ensure that it does not interfere or obstruct the heater's service panel. Keep any electrical supply cord away from any heated surfaces.

**⚠ WARNING****Electric Shock Hazard**

Do not force the three-prong plug into the grounded outlet, modify the plug, or use an adapter. Never operate this appliance if the cord or plug is damaged.

## Thermostat Connection

**NOTE:** Different thermostats operate according to their particular features. Refer to thermostat specifications for details.

DSRF Series heaters may be controlled by a thermostat or switch. The control voltage is 24 VAC (supplied by internal transformer) and the burner control box is equipped with a 60" black 24 VAC control wire. **Do not supply 120 VAC to the 24 VAC connection.**

Figure 3.24 • Field Wiring Diagram - Controlling a single heater with a single control device

Starting Amp Draw: 4.8 Amps

Running Amp Draw: 1.1 Amps

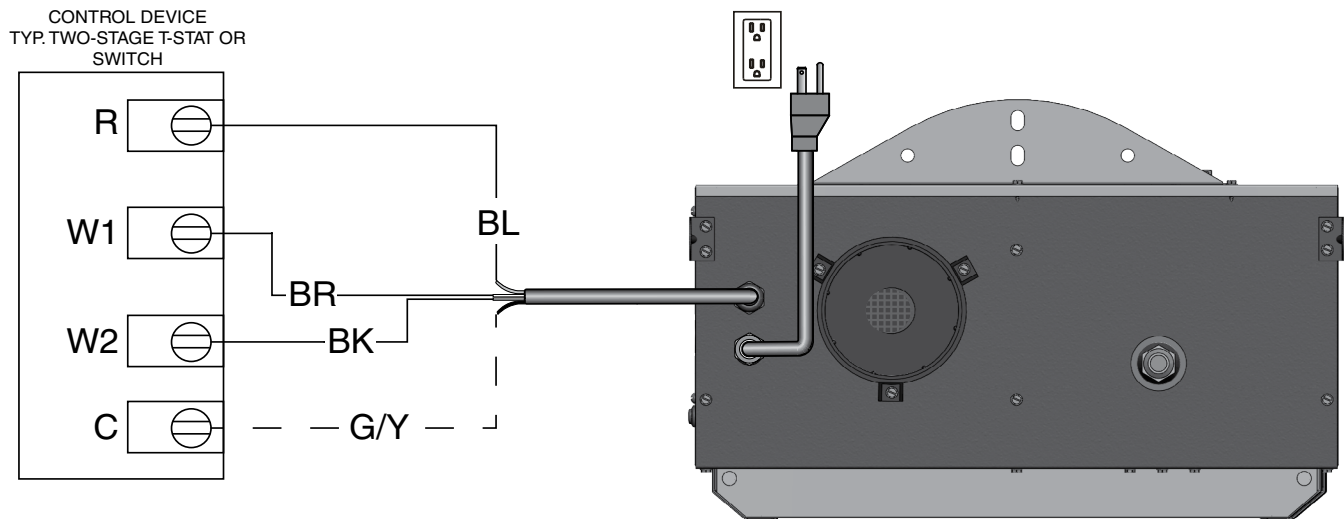
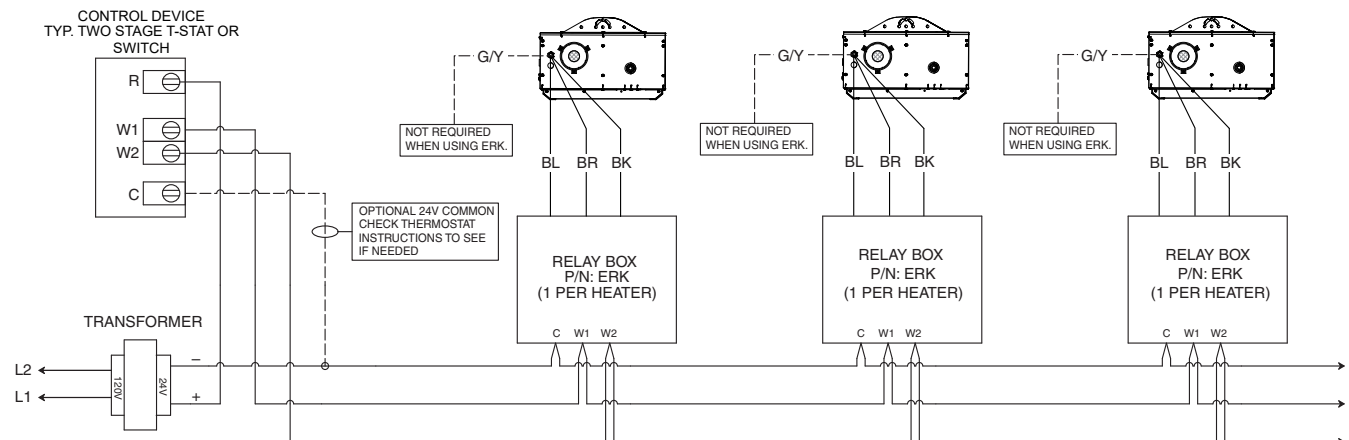


Figure 3.25 • Field Wiring Diagram - Controlling multiple heaters with a single control device

Starting Amp Draw: 4.8 Amps

Running Amp Draw: 1.1 Amps



### Field Wiring:

- 1 When controlling multiple heaters with a single control device, one ERK or ERK-HE per heater is required.
- 2 An external 24 VAC transformer (0.2 Amp) per heater is required (supplied by installer).
- 3 Maintain electrical polarity when hooking up multiple heaters.
- 4 Allow heaters to be switched by zones for heating flexibility.
- 5 Do not attempt to install transformer inside of heater.

# 4.0 Operation

---

## Sequence of Operation

---

**Standby:** The ignition module (circuit board) continually checks for internal faults, circuit integrity, and relay contact positioning.

**Starting Circuit:** Upon a call for heat, the control verifies that the differential switch is in the proper position (open). The control energizes the fan. Once operational static pressure is achieved, the differential switch will close initiating the ignition sequence. The glo-bar is powered and the gas valve opens after 45 seconds. If the flame is not sensed, the heater will attempt to re-ignite for a total of three (3) trials for ignition before proceeding to Soft Lockout.

**Low Fire Running Circuit:** After ignition, the flame rod monitors burner flame. If sense of flame is lost, the control closes the gas valve within one second and a new trial sequence (identical to the starting sequence) is initiated. If flame sense is not established within 8.5 seconds, the heater will attempt two (2) additional ignition sequences before proceeding to Soft Lockout. The control can be reset by briefly interrupting the power source.

**High Fire Running Circuit:** The second stage on the gas valve is powered directly from the second stage of the thermostat. In order for high fire to engage, low fire must be energized as well. The thermostat determines which stage to maintain for the desired temperature.

**Shut Down:** When the thermostat is satisfied, the fan will enter a two (2) minute post-purge cycle.

## Diagnostics

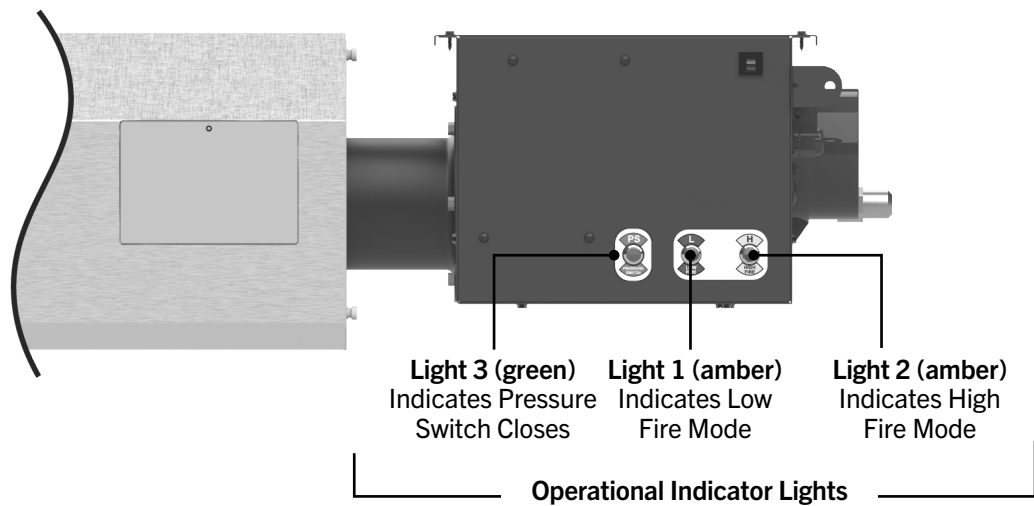
This heater is equipped with a resettable inline fuse. The controls will automatically lockout the heater system when an external or system fault occurs. There are two types of lockout:

**Soft Lockout:** The heater will attempt to light three times. In the event of a failed attempt to light (gas pressure, valve, no flame sense, etc.), the heater will enter a Soft Lockout period for 30 minutes, then attempt to light three more times before entering Hard Lockout mode.

**Hard Lockout:** If proof of flame is not established, a component failure occurs, or blockages are evident, the heater will enter Hard Lockout. If lockout occurs, the control can be reset by briefly interrupting the power source. Refer to Chart 4.1 below for a description of LED codes.

**Figure 4.1 • External LED Operation Indicator Lights**

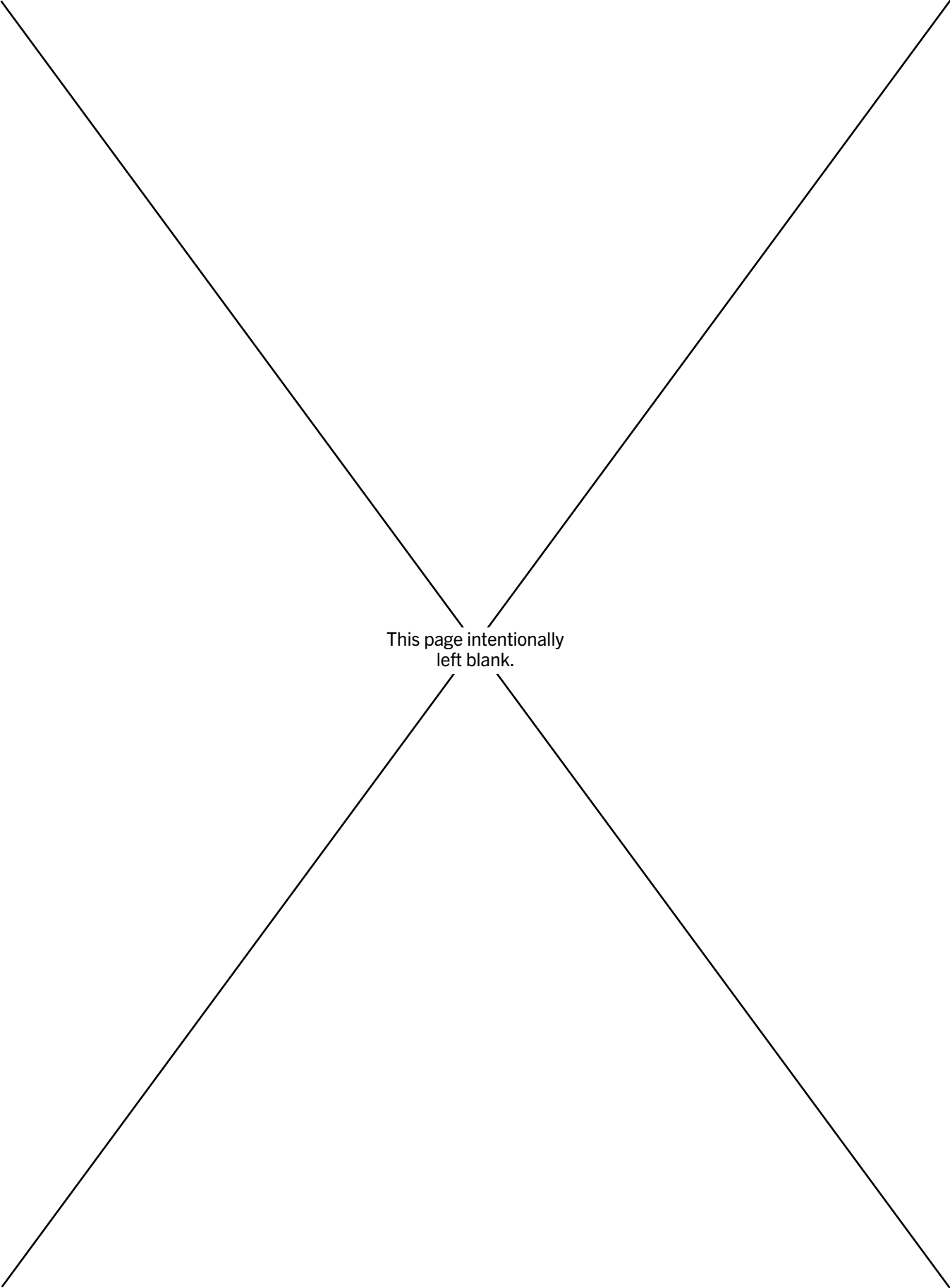
**NOTE:** Hard Lockout LED CODE will appear upon completion of the Soft Lockout sequence of operation.



**Chart 4.1 • LED Fault Code Status (Located on Circuit Board Inside Control Box)**

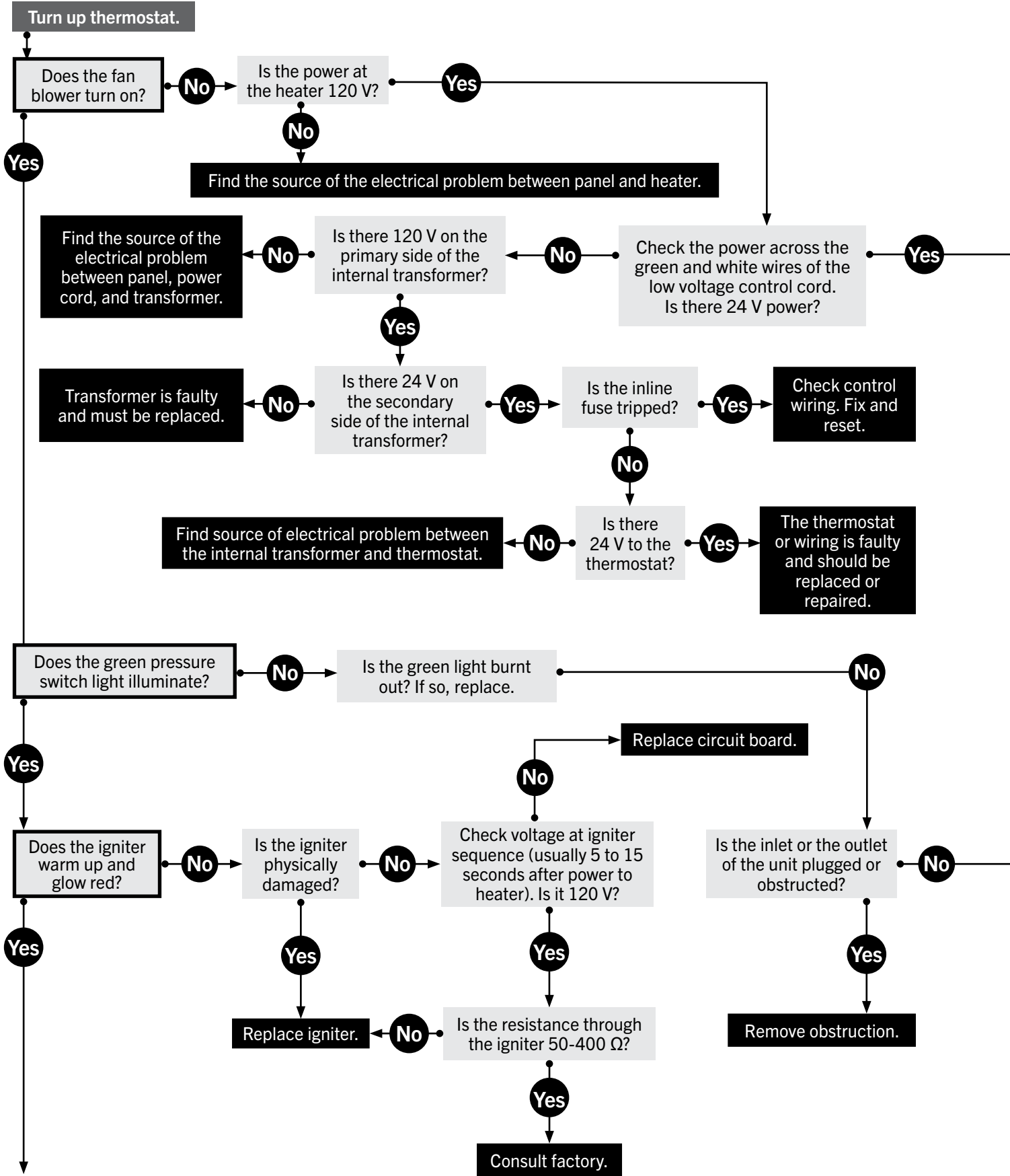
LED Code	Fault Status	Fault Code Delay*
Initial flash on power up, then steady off	No fault, normal operation	No Delay
Steady ON	Module failure / Internal fault	No Delay
1 flash	Ignition failure	3 minutes
2 flash	APS (Air Proving Switch) Fan / Intake / Exhaust	1 - 30 seconds
4 flashes	Erroneous flame signal	No Delay
No flash on 117 V startup	Transformer fault	No Delay

\* Some LED codes have a time delay before the LED will flash.



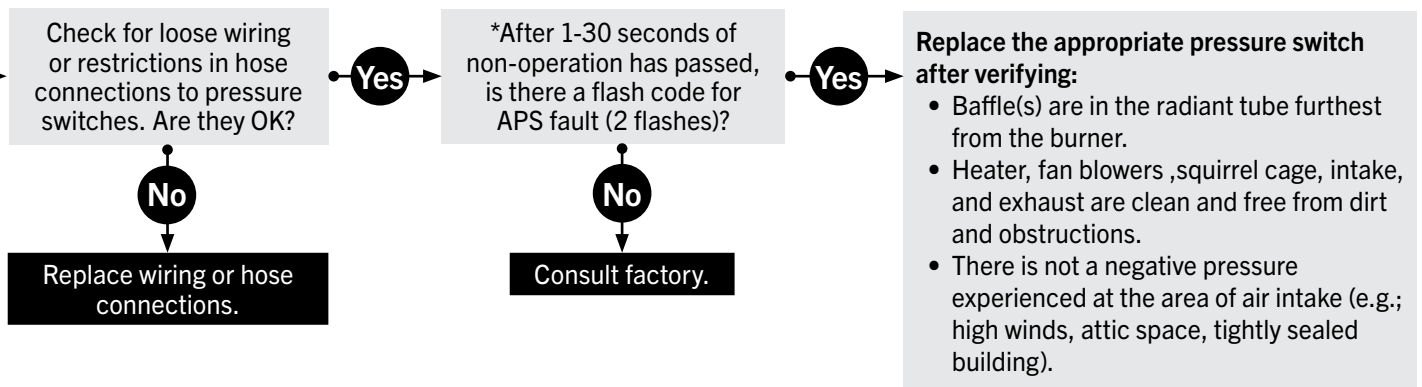
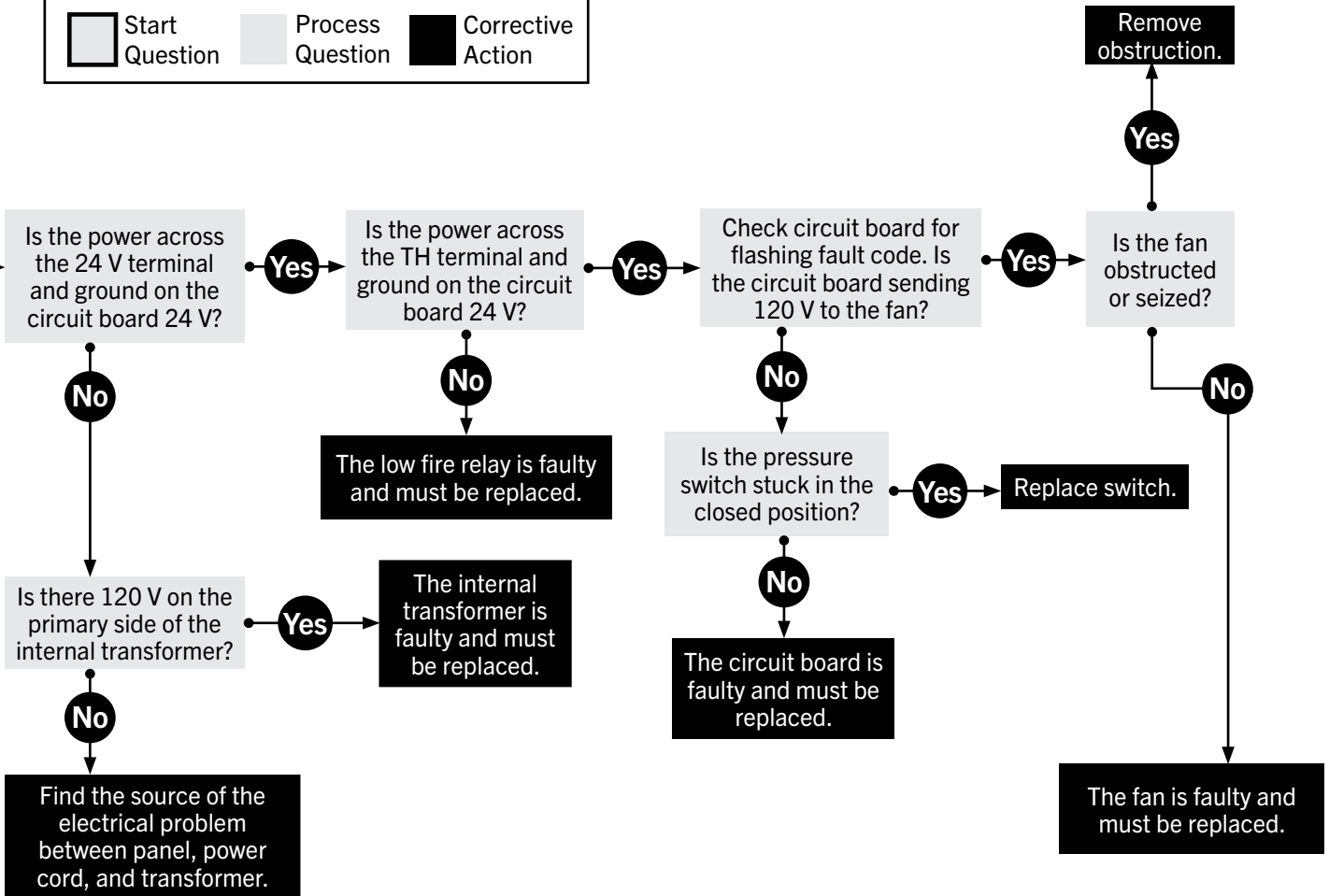
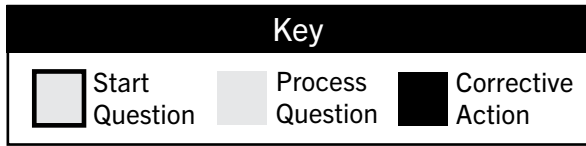
This page intentionally  
left blank.

# 5.0 Troubleshooting Guide



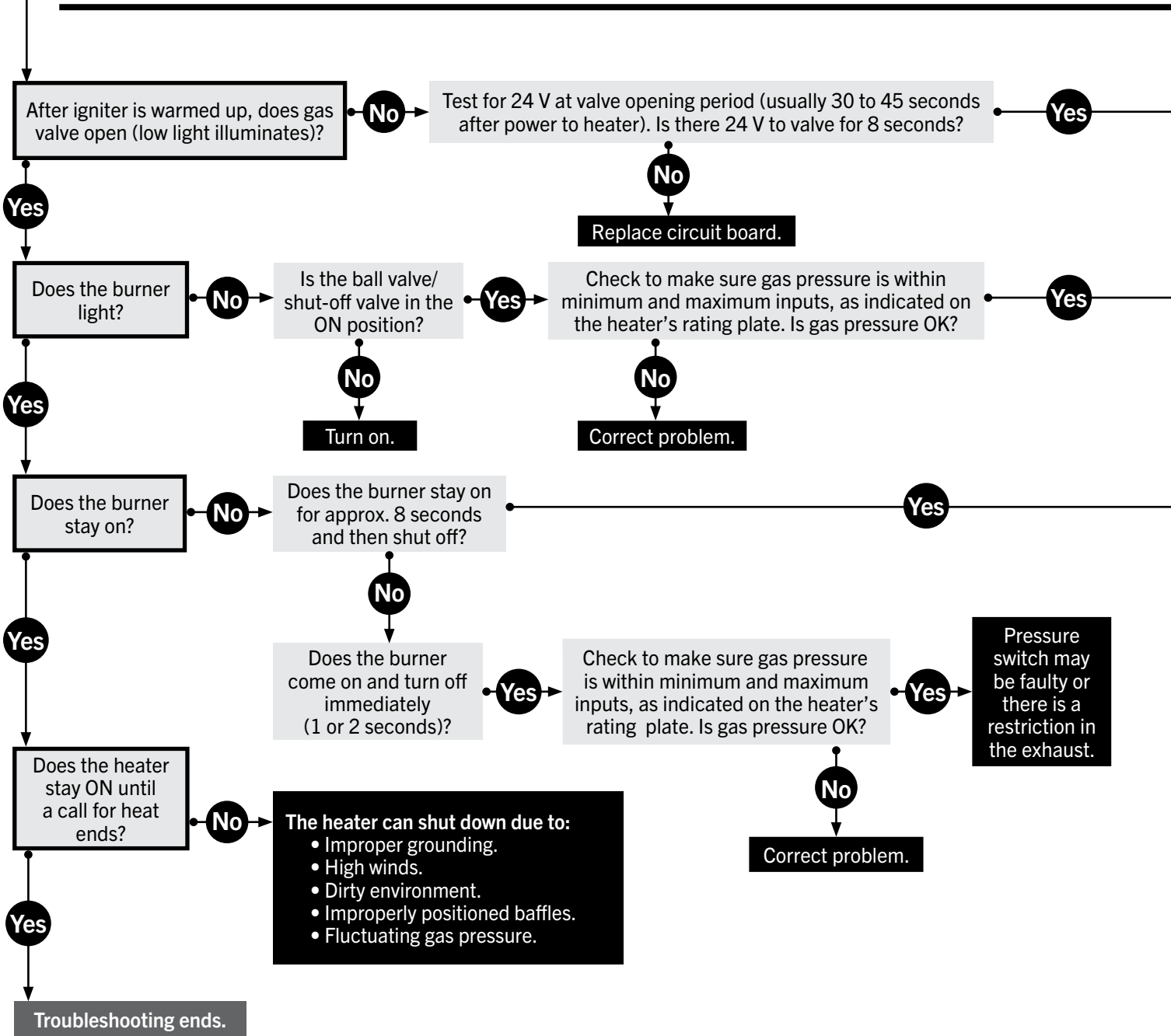
Continued on page 42

**NOTICE** Bypassing any switch is intended for testing purposes only. Do **not** leave switch bypassed during normal operation or the heater’s built-in safety mechanisms will be compromised.

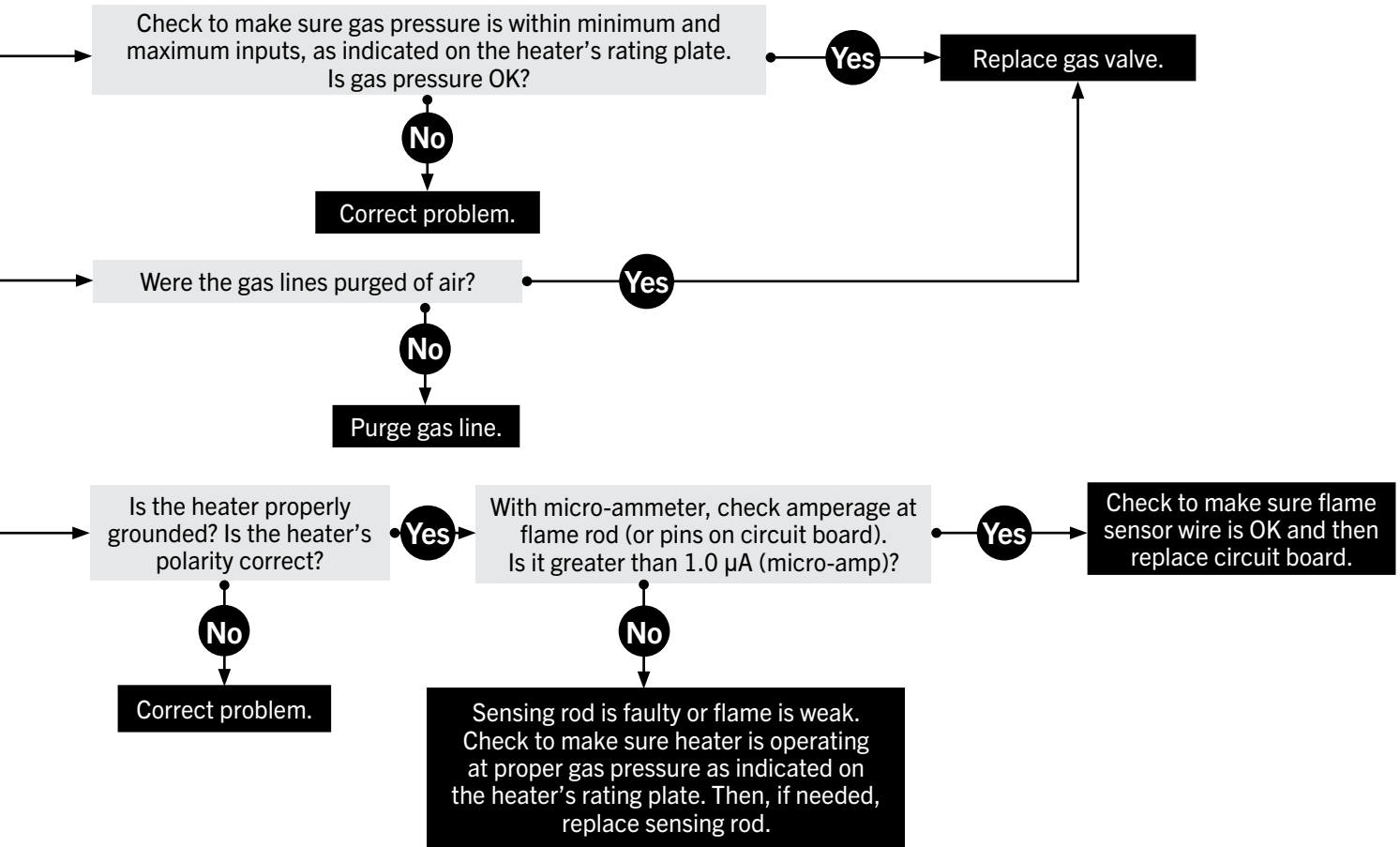


\*Refer to LED diagnostic Fault Code Chart; p.38.

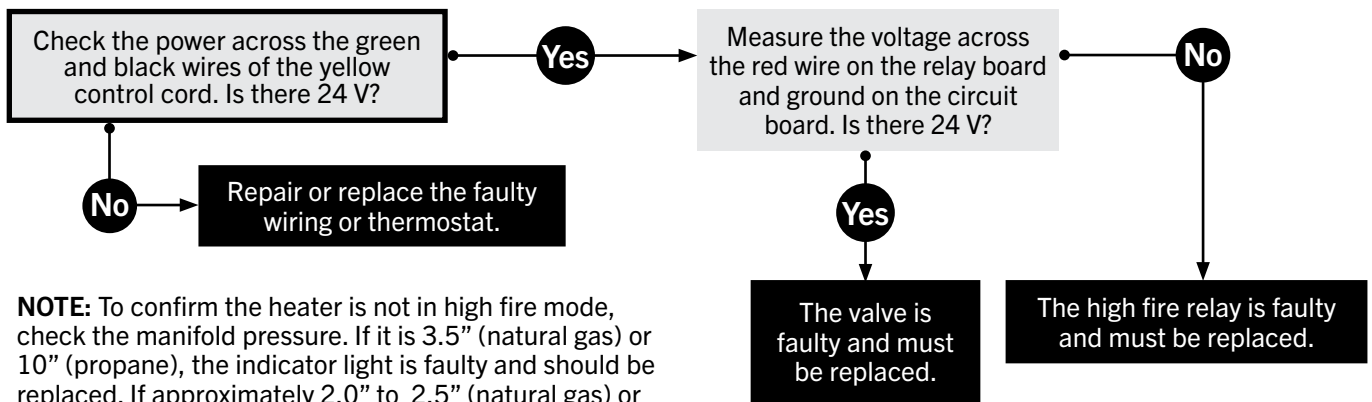
Continued from page 40.



**NOTICE** Bypassing any switch is intended for testing purposes only. Do **not** leave switch bypassed during normal operation or the heater's built-in safety mechanisms will be compromised.



**If the heater does not enter high fire mode, check the following:**



**NOTE:** To confirm the heater is not in high fire mode, check the manifold pressure. If it is 3.5" (natural gas) or 10" (propane), the indicator light is faulty and should be replaced. If approximately 2.0" to 2.5" (natural gas) or 5.0" to 6.5" (propane), the heater is in low fire mode and the troubleshooting steps described here should be followed.

# 6.0 Maintenance

## ⚠ WARNING



Personal injury or death may result if maintenance is not performed by properly trained gas installer or service personnel. Contact the installing distributor or place of purchase for service. **Do not operate heating system if repairs are necessary.**



Allow heater to cool prior to servicing.

Disconnect power to heater before servicing.

Use protective glasses when maintaining the heater.

### Routine Maintenance and Inspection:

At least once per year, the heating system should be inspected and serviced by trained gas installation and service personnel only. This inspection should be performed at the beginning of the heating season to ensure that all heater components are in proper working order and that the heating system operates at peak performance. Particular attention should be paid to the following items.

- **Clearances to Combustibles:** Inspect the area near the unit to be sure there is no combustible material located within the minimum clearance requirements listed in this manual. Under no circumstances should combustible material be located within the clearances specified in this manual. Failure to provide proper clearance could result in personal injury or equipment damage from fire.
- **Gas Connection:** Inspect the integrity of the gas connection to the heater. Check for leaks, damage, fatigue, or corrosion. Do not operate if repairs are necessary and turn off gas supply to the heater. Contact service personnel.

To check gas tightness of the safety shut-off valves, turn off the manual valve upstream of the appliance combination control. Remove the hex head plug on the inlet side of the combination control and connect a manometer to that tapping.

Turn the manual valve on the apply pressure to the combination control. Note the pressure reading on the manometer, then turn the valve off. Any loss of pressure indicates a leak. If leak is detected, use a soap solution to check all threaded connection. If no leak is found, combination control is faulty and must be replaced before putting appliance back in service.

- **Blower Motor:** Ensure that the squirrel cage in the blower is kept clean. If dirt becomes a problem, installation of outside air intake ducts for combustion is recommended.
- **Heat Exchangers:** Check the integrity of the heat exchangers. Replace if there are signs of structural failure. Check for corrosion and/or buildup within the tube exchanger passageways.
- **Burner:** Check for proper ignition, burner flame, and flame sense. Flame should extend directly outward from burner without floating or lifting.
- **Wiring:** Check electrical connections for tightness and/or corrosion. Check wires for damage.
- **Gas Connection:** Inspect the integrity of the gas connection to the heater. Check for leaks, damage, fatigue, or corrosion. Do not operate if repairs are necessary and turn off gas supply to the heater. Contact service personnel.



# 7.0 Parts

Figure 7.1 • Burner Assembly Components

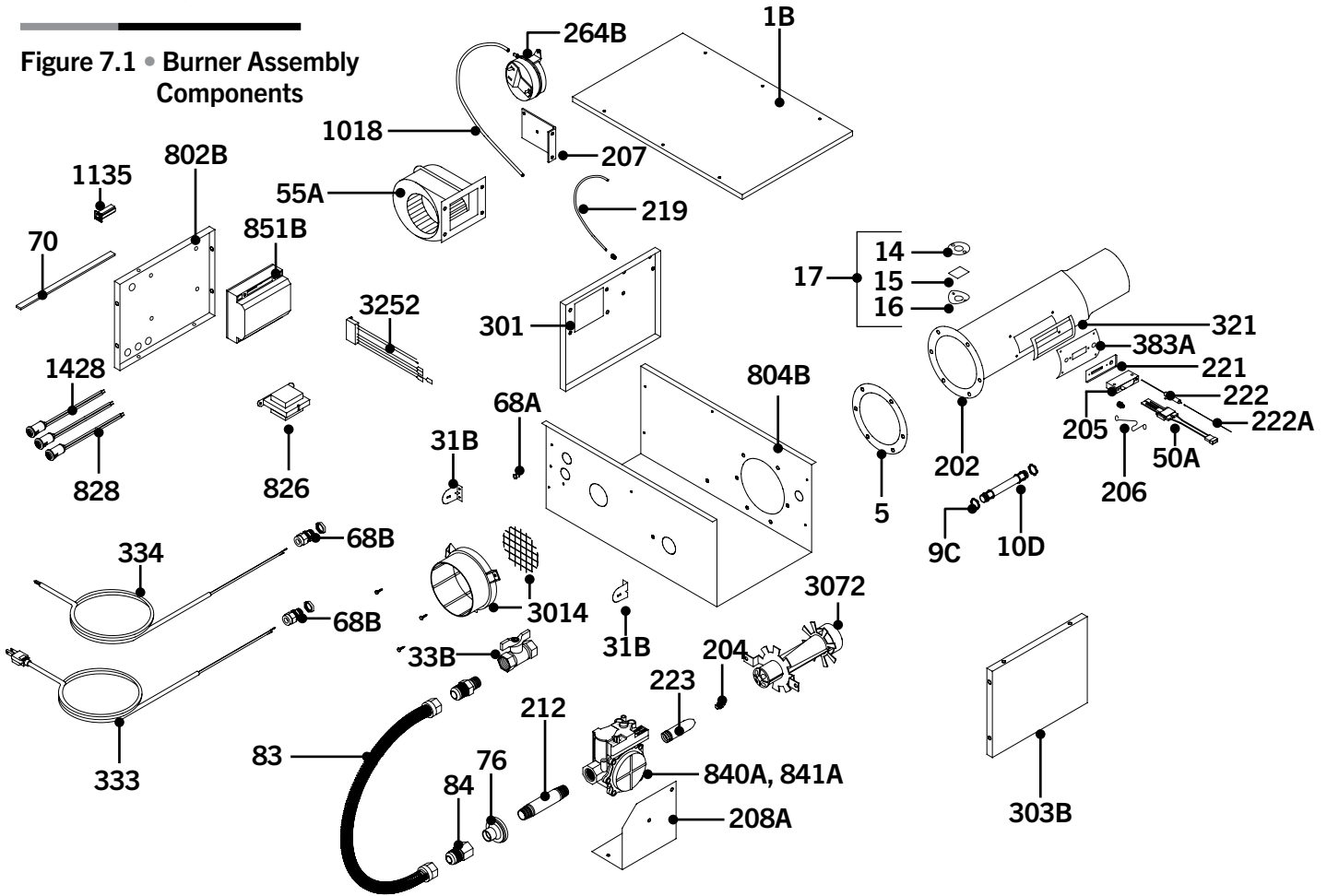


Chart 7.1 • Parts List

Part No.	Description	Part No.	Description
TP-1B	Control Box Cover - Black	TP-83	24" Stainless Steel Flexible Gas Connector
TP-5	Flange Gasket	TP-84	1/2" Female/Male Flare Fitting
TP-9C	3/4" Conduit Coupling and Nut	TP-202	16" HSI Burner Tube with Flange
TP-10D	3" x 3/4" Metal Conduit	TP-204	Gas Orifice (consult factory)
TP-14	Sight Glass Gasket	TP-205	Glo-Bar™ Holder
TP-15	Sight Glass	TP-206	Glo-Bar™ Holder Spring Clip
TP-16	Sight Glass Washer	TP-207	Pressure Switch Mounting Bracket
TP-17	Sight Glass Kit	TP-208A	Gas Valve Mounting Bracket
TP-31B	Control Box Mounting Bracket	TP-212	1/2" x 3" Pipe Nipple
TP-33B	1/2" Shut-Off Ball Valve / Inlet Tap	TP-219	Diff. Vinyl Sensing Tube (Burner)
TP-50A	Glo-Bar™ Ignitor	TP-221	Glo-Bar™ Holder Gasket
TP-55A	Fan Blower	TP-222	Flame Rod
TP-65I	36" Interlocking Turbulator Baffle	TP-222A	Flame Rod Wire
TP-68A	Strain Relief Bushing	TP-223	Gas Manifold
TP-68B	Large Strain Relief Bushing	TP-264B	Differential Pressure Switch
TP-70	Control Box Cover Gasket (per foot*)	TP-301	Burner Control Box Center Panel
TP-76	Rubber Grommet	TP-303B	End Panel, Right - Black

\* 6 feet total required to cover outer edges of the burner control box.

Figure 7.2 • Tube and Reflector Components

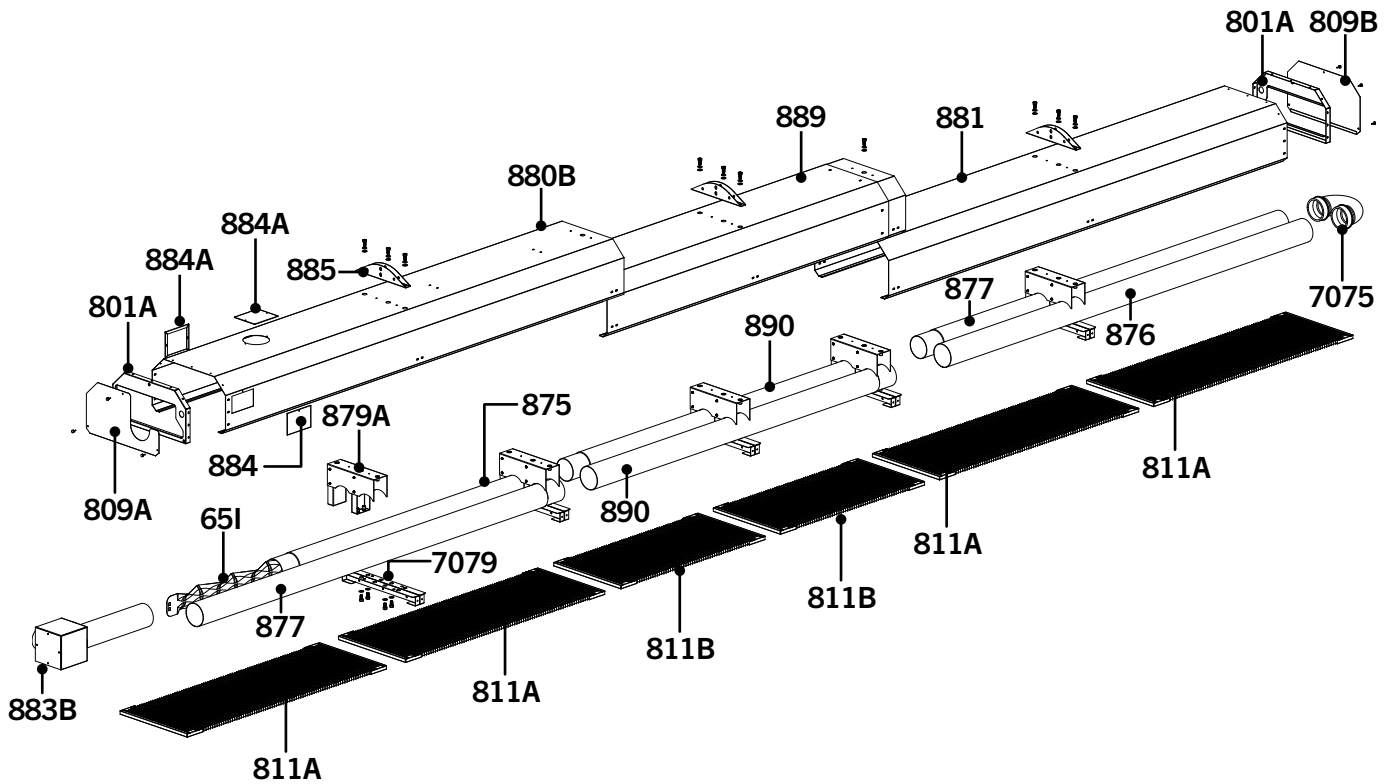


Chart 7.1 • Parts List (cont.)

Part No.	Description	Part No.	Description
TP-321	Ignition Plate Gasket	TP-877	7' Swaged Tube
TP-333	6 ft. Black 120 VAC Power Cord	TP-879A	Mounting Bracket Assembly
TP-334	Yellow Control Cord	TP-880B	Burner End Reflector
TP-383A	Glo-Bar™ Ignitor Plate	TP-881	U-End Reflector
TP-801A	Reflector End Cover Support	TP-883B	Exhaust Diffuser Box
TP-802B	End Panel, Left - Black	TP-884	Service Access Panel
TP-804B	Burner Control Box Outer Shell - Black	TP-884A	Vent Access Panel
TP-809A	Reflector End Cover (Burner End)	TP-885	Mounting Bracket
TP-809B	Reflector End Cover (U-End)	TP-889	5' Reflector (DSRF-35 Models Only)
TP-811A	Long Egg Crate Assembly	TP-890	70" Swaged Tube (DSRF-35 Models Only)
TP-811B	Short Egg Crate Assembly	TP-1018	Diff. Switch Silicone Sensing Tube (Exhaust)
TP-826	40 VA Transformer	TP-1135	Resettable Inline Fuse
TP-828	Amber Operational Indicator Light	TP-1428	Green Operational Indicator Light
TP-840A	Two-Stage Natural Gas Valve Assembly	TP-3014	Air Orifice (consult factory)
TP-841A	Two-Stage Propane Gas Valve Assembly	TP-3072	Burner (Green)
TP-851B	35-66 Diagnostic Circuit Board	TP-3252	Wire Harness
TP-875	5' Swaged Tube	TP-7075	U-Bend
TP-876	7' Unswaged Tube	TP-7079	Mounting Bracket Assembly Support

## Limited Warranty Terms and Conditions

---

**Three-Year Limited Warranty:** The heaters covered in this manual are warranted by Detroit Radiant Products Company to the original user against defects in workmanship or materials under normal use for three years after date of purchase. Any part which is determined to be defective in material or workmanship and returned to an authorized service location, as Detroit Radiant Products Company designates, shipping costs prepaid, will be, as the exclusive remedy, repaired or replaced at Detroit Radiant Products Company's option. For limited warranty claim procedures, see PROMPT DISPOSITION below. This limited warranty gives purchasers specific legal rights which vary from jurisdiction to jurisdiction.

**Additional Limited Warranty:** In addition to the above mentioned three-year warranty, Detroit Radiant Products Company warrants the original purchaser an additional extension on the heat exchangers and burners. This extension excludes electrical/purchased components.

**General Conditions:** The Company will not be responsible for labor charges for the analysis of a defective condition of the heater or for the installation of replacement parts. The warranties provided herein will not apply if the input of the heater exceeds the rated input at time of manufacturing or if the heater in the judgment of the Company has been subjected to misuse, excessive dust, improper conversion, negligence, accident, corrosive atmospheres, excessive thermal shock, excessive vibration, physical damage to the heater, alterations by unauthorized service personnel, operation contrary to the Company's instructions or if the serial number has been altered, defaced, or removed. The Company shall not be liable for any default or delay in the performance of these warranties caused by contingency beyond its control, including war, government restriction or restraints, strikes, fire, flood, short or reduced supply of raw materials, or parts.

**Limitation of Liability:** To the extent allowable under applicable law, Detroit Radiant Products Company's liability for consequential and incidental damages is expressly disclaimed. Detroit Radiant Products Company's liability in all events is limited to and shall not exceed the purchase price paid.

**Warranty Disclaimer:** Detroit Radiant Products Company has made a diligent effort to provide product information and illustrate the products in this literature accurately; however, such information and illustrations are for the sole purpose of identification, and do not express or imply a warranty that the products are merchantable, or fit for a particular purpose, or that the products will necessarily conform to the illustrations or descriptions. Except as provided below, no warranty or affirmation of fact, expressed or implied, other than as stated in the "LIMITED WARRANTY" above is made or authorized by Detroit Radiant Products Company.

**Product Suitability:** Many jurisdictions have codes and regulations governing sales, construction, installation, and/or use of products for certain purposes, which may vary from those in neighboring areas. While Detroit Radiant Products Company attempts to assure that its products comply with as many codes, it cannot guarantee compliance, and cannot be responsible for how the product is installed or used. Before purchase and use of a product, review the product applications, and all applicable national and local codes and regulations, and be sure that the product, installation, and use will comply with them. Certain aspects of disclaimers are not applicable to consumer products: e.g., (a) some jurisdictions do not allow the exclusion or limitation of incidental or consequential damages, so the above limitation or exclusion may not apply to you: (b) also, some jurisdictions do not allow a limitation on how long an implied warranty lasts, consequently the above limitation may not apply to you: and (c) by law, during the period of this limited warranty, any implied warranties of implied merchantability or fitness for a particular purpose applicable to consumer products purchased by consumers, may not be excluded or otherwise disclaimed.

**Prompt Disposition:** Detroit Radiant Products Company will make a good faith effort for prompt correction or other adjustment with respect to any product which proves to be defective within limited warranty. For any product believed to be defective within limited warranty, first write or call dealer from whom the product was purchased. Dealer will give additional directions. If unable to resolve satisfactorily, write to Detroit Radiant Products Company at 21400 Hoover Road, Warren, Michigan 48089, listing dealer's name, address, date and number of dealer's invoice, and describe the nature of the defect. Title and risk of loss pass to buyer on delivery to common carrier. If product was damaged in transit to you, file claim with carrier.

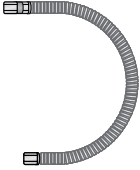
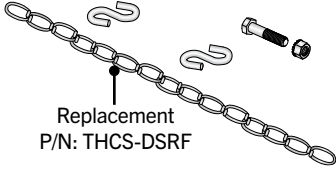
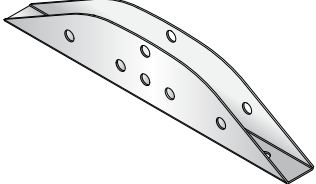
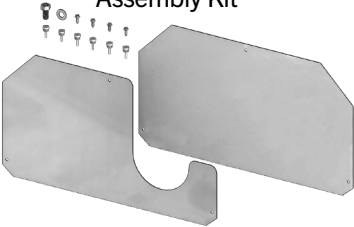
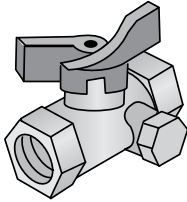







## Kit Contents Check List

Chart 7.2 • Kit Contents for DSRF Series

DSRF Series Kit Contents			
<p><b>TP-83</b> 1/2" x 24" 304 Stainless Steel Flexible Gas Connector</p> 	<p><b>DSR-HANG*</b> Hanging Kit</p>  <p>Replacement P/N: THCS-DSRF</p>	<p><b>TP-885</b> Hanging Bracket</p> 	
<p><b>DSR-ASSY</b> Assembly Kit</p> 	<p><b>TP-33B</b> 1/2" Shut-Off Valve (Ball Valve &amp; Inlet Tap)</p> 	<p><b>LIODSRF</b> DSRF Series Installation, Operation, and Maintenance Manual</p> 	
Part No.	Description	DSRF-30 Qty.	DSRF-35 Qty.
TP-33B	1/2" Shut-Off Valve and Inlet Tap	1	1
TP-83	1/2" x 24" 304 Stainless Steel Flexible Gas Connector	1	1
TP-885	Hanging Bracket	2	3
DSR-ASSY	3/8-16 x 1" Bolt	7	11
	Flat Washer	7	11
	Lock Washer	7	11
	#10 x 5/8" Stainless Steel Self-Drilling Screw	8	14
	Thumb Screw	6	6
	Reflector End Panel Bracket (Burner End)	1	1
	Reflector End Panel Bracket (U-End)	1	1
DSR-HANG*	3/8-16 x 1 3/4" Stainless Bolt	4	6
	Stainless Steel Keps Nuts	4	6
	Stainless Steel S-Hooks	12	16
	#1/0 Stainless Steel Bulldog Chain	6	8
<b>Filled By:</b>			

\* DSR-HANG Kit is not included when optional hanging bracket kit (P/N: DS-BKT20 or DS-BKT33) is ordered.

### Approvals

- CSA
- Commercial/Industrial Indoor
- Commercial/Industrial & Residential Outdoor

### Limited Warranty

- 3 years - Burner box components
- 5 years - Combustion and radiant tubes
- 10 years - Stainless steel burner
- See page 48 for terms and conditions.



© 2025 Detroit Radiant Products Co.  
21400 Hoover Road • Warren, MI 48089  
Phone: (586) 756-0950 Fax: (586) 756-2626  
www.detroitradiant.com • sales@drp-co.com

