

DSRF SERIES

RE-VERBER-RAY®

by Detroit Radiant Products Company

Designer Series

GAS-FIRED, DECORATIVE, TWO STAGE, VENTED LOW INTENSITY PATIO HEATER

Specifically designed for comfort and reliability. Ideal for driving ranges and restaurant patios that require a vented solution.

The DSRF Series is a top-of-the-line patio heater with an aesthetically pleasing, modern design featuring two stage technology. This gas-fired, vented low intensity patio heater was manufactured specifically with the outdoor market in mind. Not only does this heater deliver an even heat pattern throughout its entire footprint, it also comes equipped with a decorative modular grille. This is the preferred heater for outdoor driving ranges requiring a vented solution.

BENEFITS OF HEATING WITH INFRARED

- Superior Comfort
- Reduced Energy Consumption
- Flexibility
- Durability
- Radiant Efficiency

PRODUCT FEATURES

- Two stage operation
- Pre- and post-purge controls
- Self-diagnostic LED, microprocessor based circuitry
- 28 to 35 linear feet of radiant tube
- Reliable hot surface ignition
- Stainless steel flexible gas connector included
- 24 V controls and power cord standard
- Highly decorative housing with modular grille
- Hanging Kit included

DSRF SERIES

GAS-FIRED, DECORATIVE, TWO STAGE, VENTED LOW INTENSITY PATIO HEATER

PRODUCT SPECIFICATIONS



Input Range:
65,000 to 100,000 BTU/h



Radiant Tubes:
.95 Emissive Black-Coated Aluminized Steel



Length:
DSRF-30: 16'-4"/DSRF-35: 21'-10"



Certification:
CSA Certified for Commercial/Industrial Indoor & Outdoor Use and Residential Outdoor Only



Gas Type:
Natural (3.5" W.C.) or Propane (10.0" W.C.)



Limited Warranty:
3 (Components) - 5 (Tubes) - 10 (Burner)



Combustion Chamber:
4" Aluminized Steel



Electrical:
120 V, 60 Hz. 24 V Control
Amps: 4.8 Starting, 1.1 Running

AVAILABLE DSRF MODELS & CLEARANCES

MODEL #	GAS ¹	BTU/h HIGH FIRE	BTU/h LOW FIRE	LENGTH	WEIGHT	MOUNTING HEIGHTS ²	CLEARANCES TO COMBUSTIBLES (INCHES)	MOUNTING ANGLE ³	SIDE	TOP	BELOW
DSRF-30-65	Nat. or Prop.	65,000	50,000	16'-4"	170 lbs.	9' to 16'			0°	25"	6"
DSRF-30-80	Nat. or Prop.	80,000	52,000	16'-4"	170 lbs.	9' to 16'	0°		25"	6"	60"
DSRF-35-65	Nat. or Prop.	65,000	50,000	21'-10"	200 lbs.	9' to 16'	0°		25"	6"	60"
DSRF-35-80	Nat. or Prop.	80,000	52,000	21'-10"	200 lbs.	9' to 16'	0°		25"	6"	60"
DSRF-35-100	Nat. or Prop.	100,000	65,000	21'-10"	200 lbs.	9' to 16'	0°		25"	6"	77"

¹ Specify natural (Nat.) or propane (Prop.) gas.

² Factory recommended mounting heights are provided as a guideline. Actual conditions may dictate variations from the above data.

³ Refer to DSRF Manual for additional information about clearances for 30° mounting angle.

Always maintain the published clearances to combustibles. Not for indoor residential use. Clearances published in DSRF Series manual and on warning labels supersede data shown on this brochure.

0° Mounting Angle

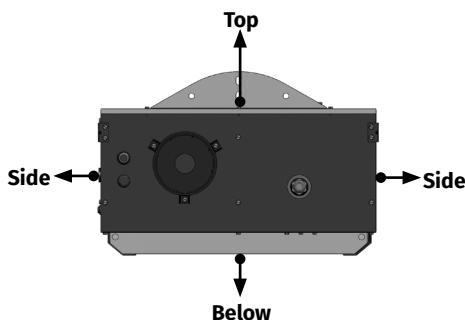

30° Mounting Angle

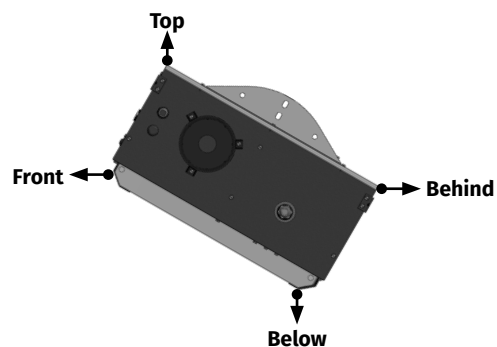

21400 Hoover Road, Warren, Michigan 48089 USA
+1.586.756.0950 | sales@drp-co.com

www.REVERBERRY.com



Form No. LBDSRF-XM-02/24 (DRPC)

