

# Low Intensity Accessory Instruction Sheet

## U-Tube Installation Instructions & Specifications (P/N: TF1B)

**Note:** For use with HL2, DX2, XTS, CL, CX, RVA2, AG2, AG1, HLV or SV Models. Consult factory for CNG applications.

### Parts List

- (1) TF1B 180° U-tube Fitting
- (1) TP-21B 4 in. Tube Clamp
- (1) TP-19B 4 in. Wire Hanger
- (2) TP-105 Reflector End Caps
- (8) TP-106 Reflector End Cap Clips

**Note:** Reflector fitting (P/N: RU) is not included. Reference warning below.

**Figure 1 • Dimensions for Heater Installed with U-tube Fitting (P/N: TF1B)**

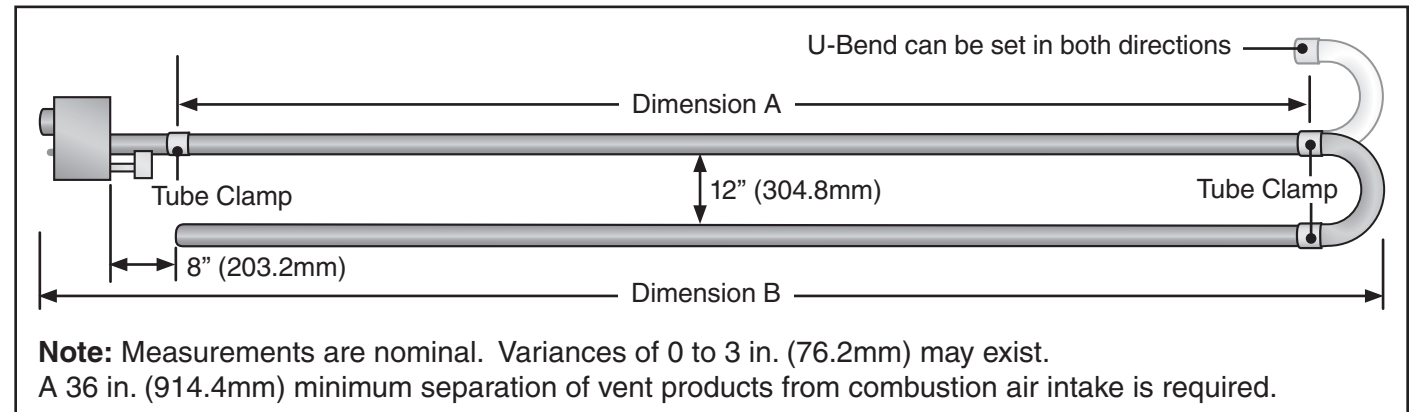

**IMPORTANT!** Refer to alternate instructions supplied with the U-tube fitting (P/N: TF1B) regarding baffle assembly instructions. One section of baffle **must** be removed if heater is installed with 4 in. (101.6 mm) O.D. U-tube accessory fitting (P/N: TF1B).

**Chart 1 • Minimum Distance From Burner Control Box to U-Bend (P/N: TF1B)**

Model BTU/H Range*	Dimension A
40,000 to 100,000	10 ft. (3m)
110,000 to 125,000	15 ft. (4.6m)
130,000 to 175,000	20 ft. (6m)
200,000	25 ft. (7.6m)

\*Consult factory for CNG applications.

**Chart 2 • Overall Dimensions for Heaters Configured with U-Bend (P/N: TF1B)**

Tube Length	Dimension B	Notes
20 ft.	13'-0" / 156"	N/A
30 ft.	17'-8" / 212"	5EA-SUB required*
40 ft.	22'-8" / 272"	N/A
50 ft.	27'-4" / 328"	5EA-SUB required*
60 ft.	32'-4" / 388"	N/A
70 ft.	37'-2" / 446"	5EA-SUB required*
80 ft.	42'-0" / 504"	N/A

\*When using the TF1B "U-bend" accessory fitting on 30 ft. (9m), 50 ft. (15m) or 70 ft. (21m) heater models, the 5EA-SUB accessory package is required and may only be ordered at the time of heater production. This option substitutes one 10 ft. (3m) tube and reflector section with two 5 ft. (1.5m) tube and reflector sections. Field corrections require (2)TR-60 packages.

### ⚠ WARNING

The top Clearance to Combustibles is 18 in. (457.2 mm) when a U-tube fitting (P/N: TF1B) is installed without a reflector cover.

**Figure 2 • 45° Angle Mounting**

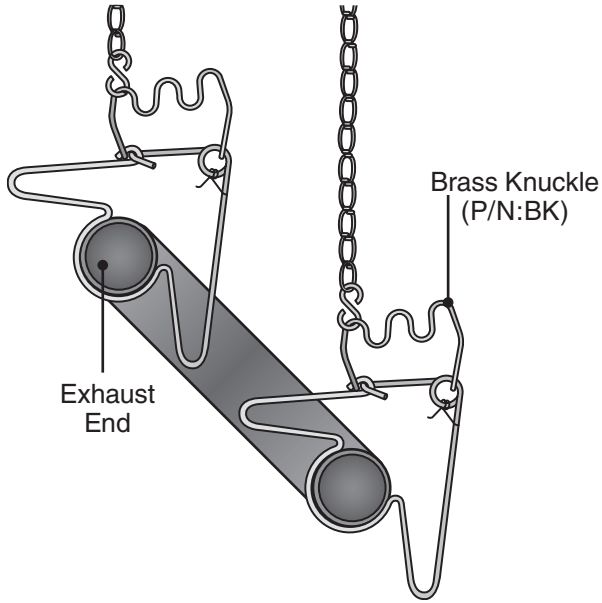

**Figure 3 • TF1B U-tube Dimensions**

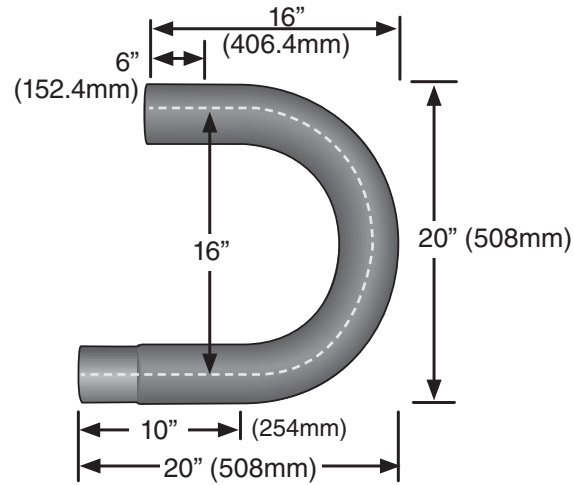

**Figure 4 • Burner Control Box Dimensions - End View**

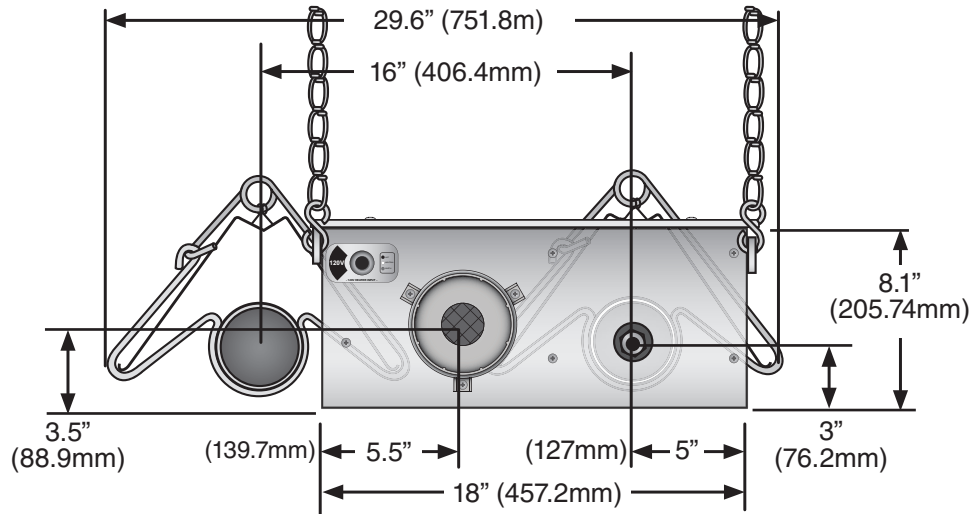

**Figure 5 • Burner Control Box Dimensions - Side View**

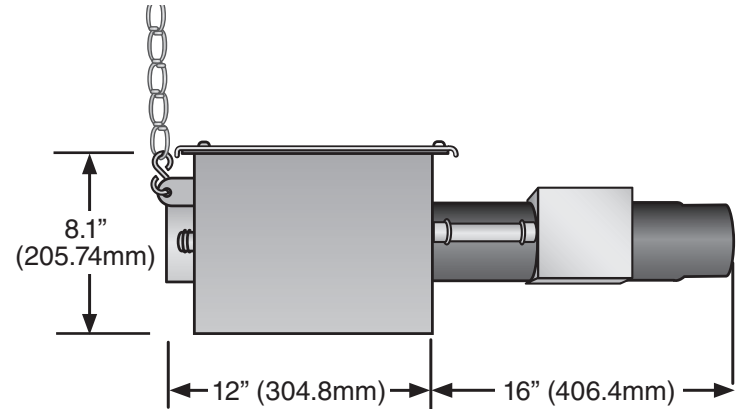

**Note:** When mounting a heater configured with a U-tube fitting (P/N: TF1B) on a 45° angle, the exhaust end of the heater must be placed higher than the burner end. The burner control box remain horizontal/level. Refer to Figure 2 above.

**Note:** Heaters configured with a TF1B can be mounted at a 15, 30 or 45 degree angle with two suspension points, using two Brass Knuckles (P/N: BK), #1 double-loop chains and S-hooks. Refer to Figure 2 above.