

# Tube Heater Accessory Sheet

## Protective Guard (PG) Installation Instructions

### Parts List

- A - (1) 60 in. Protective Guard
- B - (2) Restraining Cables
- C - (1) 4" Reflector Center Support

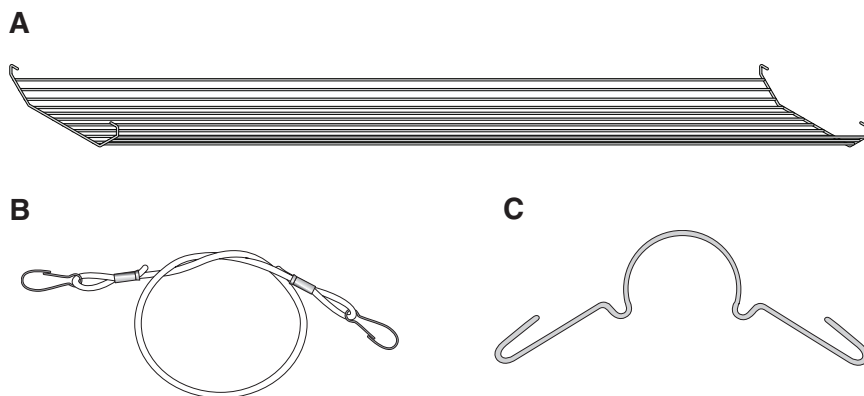

### Installation Instructions

- 1 Install reflector center supports (C) on the exchanger tube prior to installing the reflectors. Reflector center supports must be installed at an equal distance apart, as shown in Figure 1.
- 2 Once the reflector center supports are installed, install the reflector according to the installation manual.  
**NOTE:** Failure to follow the proper procedure when attaching the reflectors will result in excessive noise and possible reflector failure.
- 3 After installing all reflector sections, install the protective guard (A) by hooking one end over the lip of the reflector, and gently swing the unit into place. The protective guard should be latched to the reflector on both sides, allowing the unit to hang freely.
- 4 Install restraining cables (B) to the protective guard (A), two per each section. Attach the clasp to the outermost rail of the protective guard, and loop it over the top of the reflector. Then, attach the opposite clasp on to the adjacent rail of the protective guard, as shown in Figure 2.
- 5 Install the second restraining cable to the protective guard on the opposite end, following the same procedure outlined in step 4. Continue to do so for the remaining sections of protective guard to be installed.

Figure 1 • Reflector Center Support

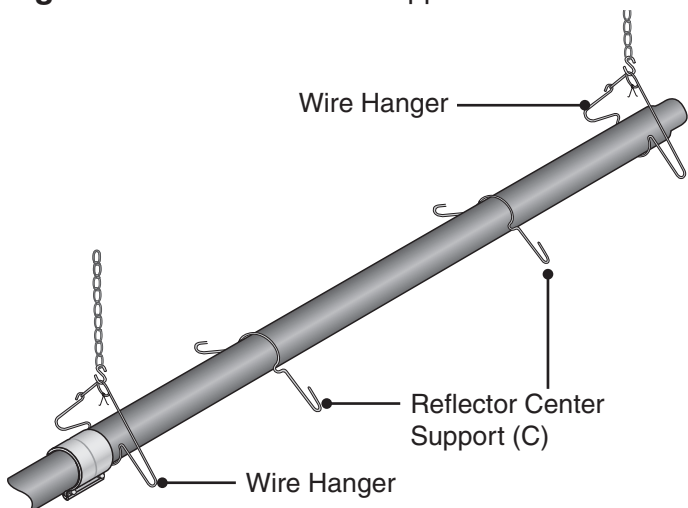

Figure 2 • Protective Guard • End View

