



INSTALLATION OPERATION MANUAL

COILS

Fluid, Single Phase Fluid or Water/Glycol

P.O. Box 1206 - Pryor, OK 74362 - (918) 825-7222 - Fax (800) 264-5329

www.rae-coils.com

1.0 TABLE OF CONTENTS

1.0 TABLE OF CONTENTS	2
2.0 NOMENCLATURE	2
3.0 RECEIVING	3
3.1 INSPECTION	3
3.2 HANDLING	3
3.3 UNPACKING/CLEANING	3
3.4 LIFTING/RIGGING	3
4.0 INSTALLATION	4
4.1 MOUNTING	4
4.2 LIFTING/RIGGING	4
5.0 PIPING	4
5.1 GENERAL NOTES	4
5.2 PIPING SCHEMATIC	4
6.0 OPERATIONS	5
7.0 MAINTENANCE	5
8.0 STORAGE	5
WARRANTY	6

CAUTION

The instructions included in this IOM are provided as guidance to the installer and service provider. All personnel working with the equipment should be qualified to do so and should perform work in accordance with all standard practices. Safety precautions should also be taken. This includes, but is not limited to, the use of gloves, steel toe boots, hard hats, and safety glasses.

2.0 NOMENCLATURE

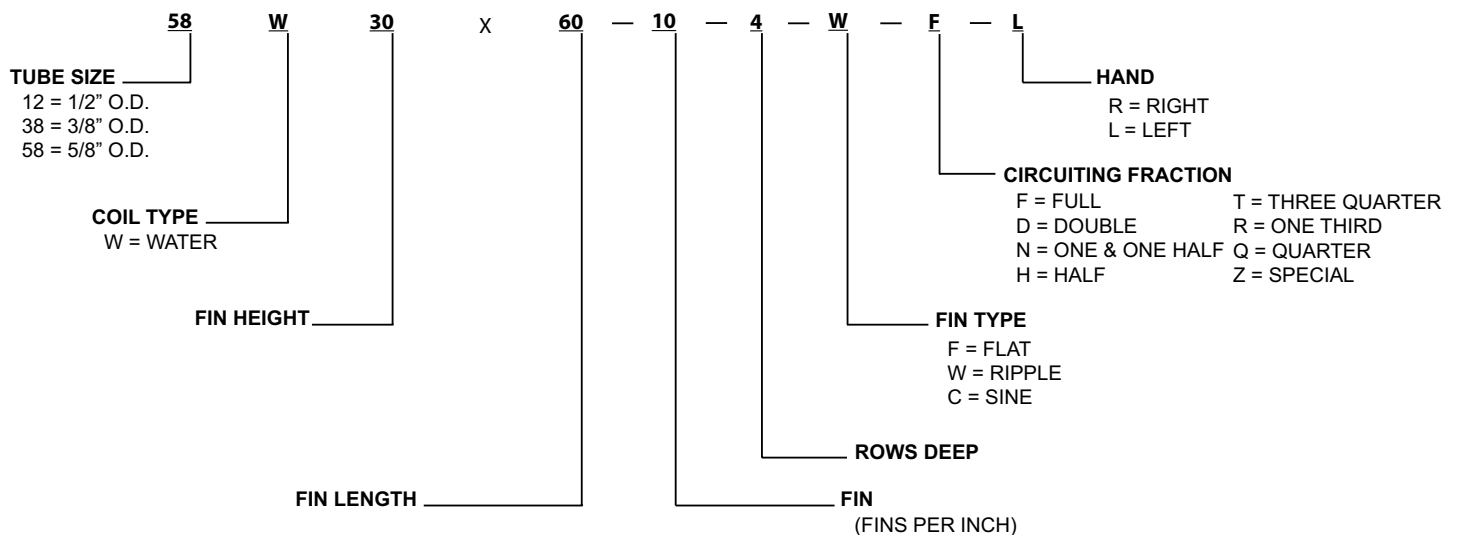

3.0 RECEIVING

3.1 INITIAL INSPECTION

Immediately upon receipt, the following should be checked:

- Bill of Lading / Original Purchase Order
- Crate
- Coil

The accuracy of the bill of lading must be checked against the physical shipment. Any loose parts are specified on the bill as separate line items. Any inaccuracies must be documented immediately on the carrier's freight bill and signed by the driver. In addition, the original purchase order and bill of lading should be equivalent. If any difference is perceived, the factory sales representative should be contacted immediately. The above nomenclature breakdown can be used to clarify any discrepancies between the physical product, the bill of lading, and the original purchase order with regards to the coils geometry.

Crates are designed to protect their contents under reasonable shipping conditions. All coils are shipped in vertical configuration and fully enclosed. Upon arrival, packaging should be inspected for broken boards. Broken boards can be an indicator of potential product damage and should be documented.

The appearance of the coil should be visually inspected upon receipt. Even though the packaging is robust, the crating is constructed with wood planks that are gapped. This slating does allow for the potential of foreign objects to contact coil surfaces (i.e. chain falls, ratcheting straps, road debris, etc.).

3.2 HANDLING

Always wear gloves when handling coils. The fins and sheet metal edges are very sharp and can seriously injure unprotected hands. All coils should be handled by the casing. Do not attempt to move, support, or lift the coil by the connection headers, tubes, fin face or other non-casing components of the coil.

3.3 UNPACKING/CLEANING

If the coil is to be stored, it should be stored in its original packaging. Once the coil is needed, it should be transported as close as possible to the point of use before unpacking.

It is recommended to disassemble the top and sides of the crating before removing its contents. Care should be taken not to damage the coil fin surfaces. If minor localized trauma does occur, then fin combs can be purchased from a HVAC supply house to re-orient the fins. If damage is localized, but extends to the refrigeration circuits, the integrity of the copper tubes must be checked. If damage to the fin surface is extensive, the coil's performance will suffer and should be corrected or replaced.

It is standard practice to insert cardboard between the outer, finned surface of the coil grouping and the inside crate surface. This helps keep the surfaces clean by reducing the threat for air and foreign debris to become embedded in the fins. However, since coil performance is dependant on air flow across the coil fins, it is recommended that all coils are cleaned before installation with a commercially available coil cleaner.

3.4 LIFTING/RIGGING

Rigging and lifting methods may include slings or other suitable devices. All slings, devices, and apparatus should be of a rating suitable for the loads they will be subjected to during the lift. Additionally, the lifting means must ensure that no deformation of the coil casing occurs.

Spreader bars must be used to hold cables or sling straps vertical and away from the coil to prevent damage to coil components.

If the coil is an unbalanced load, use all lifting points and adjust cables/slings and cable/sling lengths for proper balance.

Recommendation: Lifting and rigging attachments are used on a crane or hoist between the hook and the item to be lifted. Lifting and rigging attachments must be properly configured for the weight of the load, the type of crane or hoist and the type of chain, rope, or hook being used to lift the load. A load leveler, or end fitting, is commonly used as a sling attachment to stabilize the load. A hoist attachment that works between the hook and the load includes a coil lifter, tongs, spreader beams and pallet lifters. Maximum load capacity, maximum lifting volume, applications, and uses are important specifications to consider.

RAE assumes no responsibility for lifting apparatus, devices, and methods used by others for rigging and lifting. Do not lift the coil from the headers.

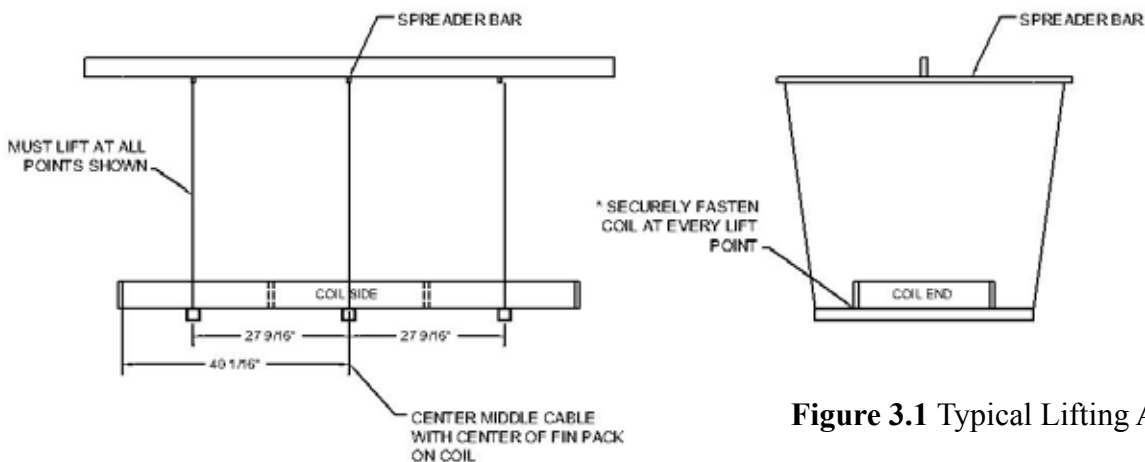

Figure 3.1 Typical Lifting Apparatus

4.0 INSTALLATION

4.1 MOUNTING

Before installing water, make sure tubes are horizontal and level. This will allow for the most effective venting and draining of coils during startup and shutdown.

Water coils used with hot water/fluid for air heating may be designed for use with either horizontal or vertical airflow provided the coil tubes are level. Installation of water coils with tubes mounted vertically is not recommended.

Coils used with chilled water/fluid should be designed for horizontal airflow with the tubes horizontal and level. Vertical airflow is not recommended for chilled water coils.

4.2 CLEARANCE

Proper clearance should be maintained between the coil and other structures, such as the fan filter racks, transition areas, etc. These clearances are typically application specific and should be based on experience. Proper clearances should result in airflow distribution tolerances listed in this IOM.

5.0 PIPING

5.1 GENERAL NOTES

All field brazing and welding should be performed using high quality materials and an inert gas purge, such as nitrogen, to reduce oxidation of the internal surface of the coil.

All piping must be fully supported at locations other than the coil. The piping should be flexible enough to provide no forces on the coils due to thermal expansion. Do not support piping from coil

or headers.

Vent each coil at its highest location to ensure the exit of gases and to promote proper drainage.

Piping should be the same size as the inlet and outlet connections.

For threaded pipe connections, use only good quality fittings with tapered threads. Use of liquid Teflon pipe joint compound is recommended. Threaded piping hook-ups should always be made using two wrenches.

Manual service valves should be installed to isolate the coil for servicing.

5.2 PIPING SCHEMATIC

After installation of the coil, it should be pressurized to 100 psig with dry nitrogen. The pressure should be held for at least 10 to 15 minutes to insure that there are no leaks. If the coil itself is found to be leaking, contact your local sales representative for warranty authorization. Unauthorized repair to the coil will void the warranty.

Open air vents, close drains, fill the coil with water and close vents. Perform a hydrostatic leak test on all piping joints to ensure there are no leaks. Drain and discard water charge.

After the coil and piping are leak tested, open all air vents so that air is eliminated from the coil tubes and headers. Verify that all vents and drains discharge a full stream of water and are not blocked.

Fill the coil with water/fluid then close all vents and drains.

During initial startup, tighten all bolted connections once the system stabilizes at operating temperature.

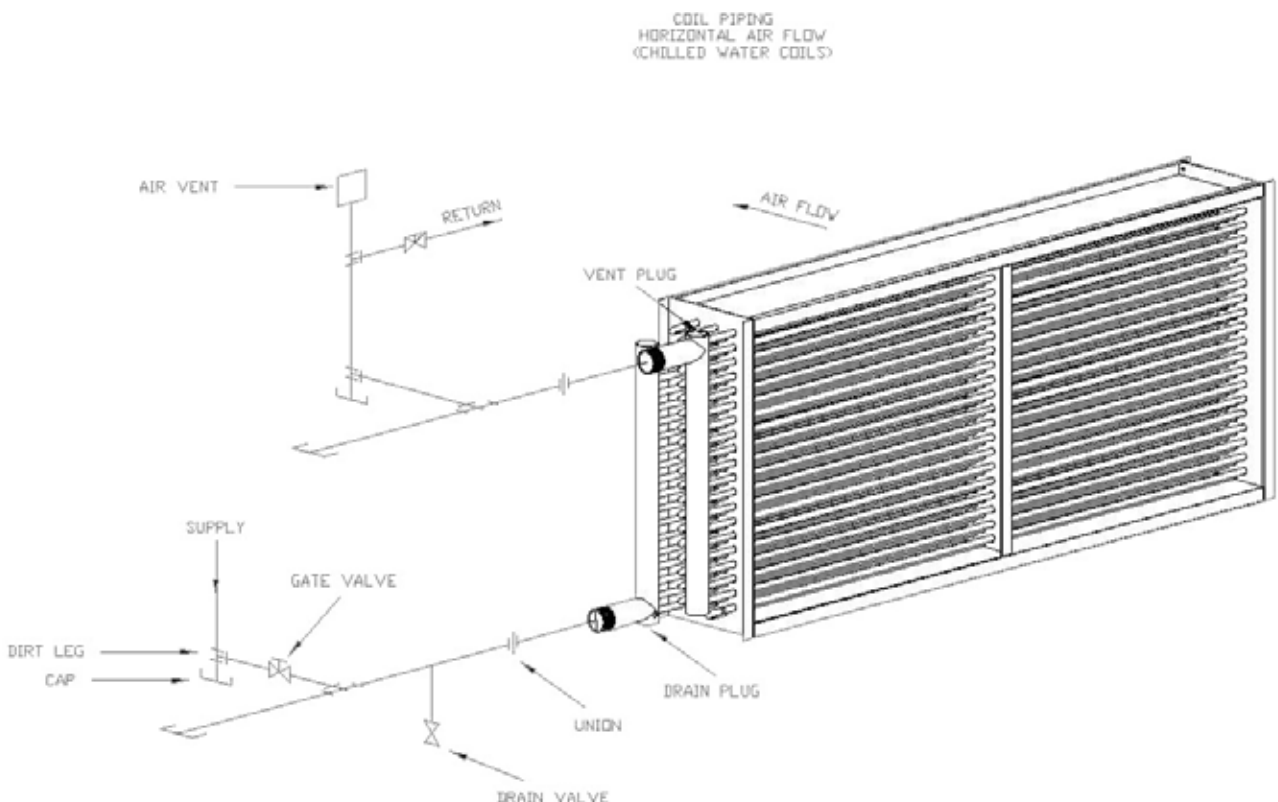

COIL PIPING
VERTICAL AIR FLOW
(RECOMMENDED FOR HOT WATER/GLYCOL COILS ONLY)

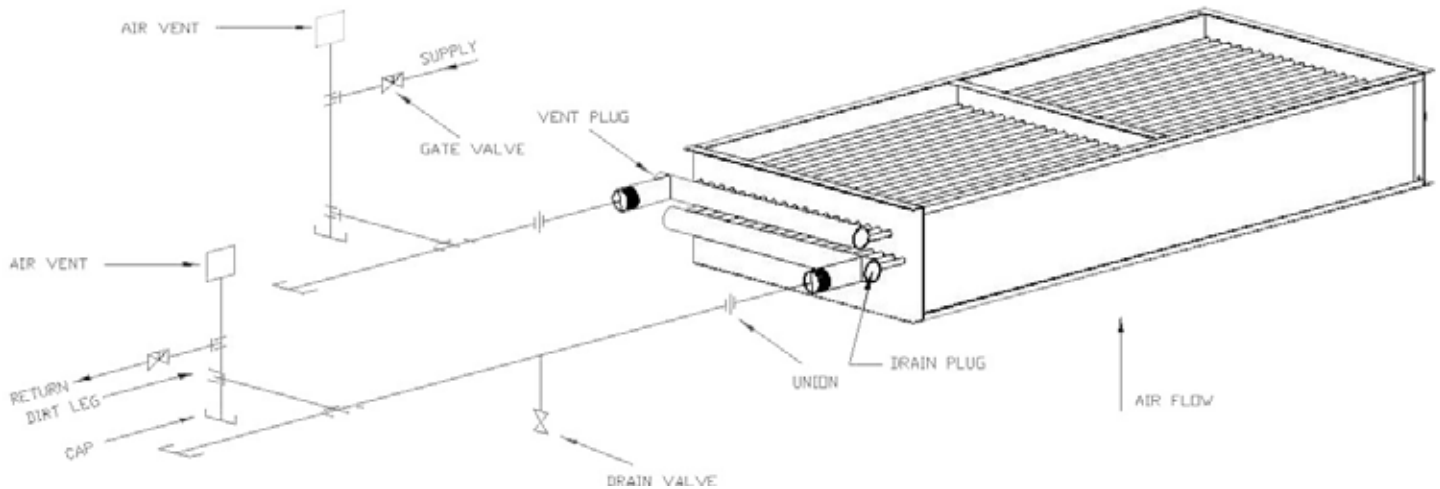

6.0 OPERATIONS

Proper air distribution is vital to coil performance. Air velocity anywhere on the coil should not vary by more than 20% from the average velocity.

- Hot water/fluid air velocities should be maintained between 200 and 1500 feet/minute.
- Dry chilled water/fluid air velocities should be maintained between 200 and 800 feet/minute.
- Wet chilled water/fluid air velocities should be maintained between 200 and 550 feet/minute.

Operating pressures must be at or below the maximum operating pressure for the coil at the fluid temperature. Contact your local sales representative for assistance. Drain coils to prevent corrosion during shutdown. In glycol based systems, always use inhibited glycols. Use of uninhibited glycols can result in corrosion of copper tubes. In chilled water systems, use the following procedure to effectively prevent **freeze** damage to water coils after shutdown during periods of cold weather.

Freeze Protection

1. Drain water from coil.
2. Blow out remaining water droplets with compressed air.
3. Completely fill coil with proper concentration of antifreeze for the lowest expected temperatures.
4. Drain antifreeze solution and replace drains and vents.

7.0 MAINTENANCE

To continually deliver full heating capacity, both the external and

internal heat transfer surfaces must be maintained as clean and corrosion free as possible. The finned surface can be maintained by the use and constant inspection of pre-filters. The filters should be replaced as needed.

Should the finned surface become fouled, the coil can be cleaned using commercially available coil cleaning fluids. Caution should be exercised in selecting the cleaning solution as well as the cleaning equipment. Improper selection can result in damage to the coil and health hazards. Be sure to carefully read and follow the cleaner manufacturer's recommendations before using any cleaning fluid. Clean the coil from the leaving airside so that foreign material will be washed out of the coil rather than pushed further in.

Keep circulating fluid, free of sediment and corrosive elements. The use of fluid filters is recommended.

Periodic venting of the coil is recommended when automatic vents are not utilized to remove accumulated air. Use caution to avoid injury. Contact with high pressure and/or high temperature fluid while venting can cause serious personal injury.

Inspect and tighten all bolted connections on a regular basis.

8.0 STORAGE

If coils are to be stored, they should be drained of any fluid and compressed air or an inert gas should be blown throughout the headers to assist in drying the coil.

If coils are to be stored, it is preferred that they are stored indoors in a clean, dry location that is level and sturdy. If they are stored outdoors, the coil should be stored off the ground and wrapped fully with a tarp or plastic.

It is recommended that the fin surface be protected by some means to prevent accidental damage.



P.O. Box 1206 • Pryor, OK 74362 • (918) 825-7222 • Fax (918) 825-6366

RAE Coils Express Limited Warranty

1. Express Limited Warranty

Subject to the terms, limitations, and disclaimer provisions set forth herein, RAE Corporation warrants to the original Purchaser that products manufactured by RAE Corporation shall be free from defects in material and workmanship under normal use. This warranty as to material and workmanship shall extend for a period of 12 months from date of shipment from RAE Corporation plant.

This warranty is issued only to the original Purchaser and is intended solely for the benefit of the original Purchaser of the products from RAE Corporation. This warranty is not transferable, applies only to a unit installed within the United States of America, its territories or possessions and Canada and is in lieu of all other warranties expressed or implied. RAE Corporation neither assumes nor authorizes any other person to assume for RAE Corporation any liabilities not herein stated.

It is agreed that in the event of breach of any of the express warranties described herein, the liability of RAE Corporation shall be limited to repairing or replacing the non-conforming goods, or, in RAE Corporation's sole discretion, repayment to the Purchaser of the purchase price paid upon return to RAE of the non-conforming goods. RAE Corporation will repair or replace, free of cost to Purchaser-User, F.O.B. factory, any part or parts that in RAE Corporation's judgment is defective. Upon RAE Corporation authorization, the said part or parts should be returned to RAE Corporation, transportation prepaid, for inspection and judgment. RAE Corporation assumes no responsibility for the expense of labor, materials, or incidental costs necessary to remove a defective part or install repaired or new parts.

The Express Limited Warranty is subject to the terms and conditions described herein.

2. General Disclaimers and Limitations on Warranty

RAE CORPORATION MAKES NO WARRANTY OF MERCHANTABILITY AND NO WARRANTY OF FITNESS FOR ANY PARTICULAR PURPOSE, NOR DOES IT MAKE ANY WARRANTY, EXPRESS OR IMPLIED, OF ANY NATURE WHATSOEVER WITH RESPECT TO PRODUCTS SOLD BY RAE CORPORATION OR THE USE THEREOF EXCEPT AS IS SPECIFICALLY SET FORTH ON THE FACE HEREOF. THIS WARRANTY, WHICH IS GIVEN EXPRESSLY AND IN LIEU OF ALL OTHER WARRANTIES, EXPRESS OR IMPLIED CONSTITUTES THE ONLY WARRANTY MADE BY THE SELLER.

THIS LIMITED WARRANTY DOES NOT COVER OR PROTECT AGAINST THE CONSEQUENCES OR EFFECTS OF ANY MISUSE, NEGLIGENCE, OR USE OF THE COIL OUTSIDE OF THE PURPOSES OR PARAMETERS FOR WHICH THE COIL WAS DESIGNED.

RAE CORPORATION SHALL IN NO EVENT BE LIABLE FOR DIRECT, INDIRECT, SPECIAL, INCIDENTAL, CONSEQUENTIAL OR PENAL DAMAGES. RAE CORPORATION MAKES NO WARRANTY OF ANY KIND, EITHER EXPRESS OR IMPLIED, TO 'CONSUMERS' AS THAT TERM IS DEFINED IN SEC. 101 OF PUBLIC LAW 93-637, THE MAGNUSON-MOSS WARRANTY-FEDERAL TRADE COMMISSION IMPROVEMENT ACT.

RAE CORPORATION SHALL NOT BE LIABLE FOR ANY DAMAGE OR DELAYS OCCURRING IN TRANSIT, FOR ANY DEFAULT OR DELAYS IN PERFORMANCE CAUSED BY ANY CONTINGENCY BEYOND ITS CONTROL INCLUDING WAR, GOVERNMENT RESTRICTIONS OR RESTRAINTS, STRIKES, SHORT OR REDUCED SUPPLY OF RAW MATERIALS, FIRE, FLOOD OR OTHER ACTS OF GOD, NOR FOR DAMAGE OR LOSS OF ANY PRODUCTS, REFRIGERANT, PROPERTY, LOSS OF INCOME OR PROFIT DUE TO MALFUNCTIONING OF SAID UNIT.

ANY AND ALL CONTROVERSIES, ISSUES, CLAIMS OR DISPUTES RELATING TO THIS PURCHASE AND SALE TRANSACTION, INCLUDING BUT NOT LIMITED TO, ANY CONTROVERSIES, ISSUES, CLAIMS AND DISPUTES CONCERNING THE INTERPRETATION OR ENFORCEMENT OF ANY WARRANTY (OR ANY LIMITATION OR OTHER ASPECT THEREOF), SHALL BE GOVERNED BY OKLAHOMA LAW.

3. Specific Limitations to Warranty

Parts Only

This warranty is limited to repair or replacement of defective parts only and does not include labor. RAE Corp., at its sole discretion, may preauthorize the inclusion of labor expense. No claim for labor charges will be allowed without a written preauthorization from RAE Corp.'s service department. Prior written approval from RAE Corp. is required, in the event RAE Corp. has authorized the customer to purchase replacement parts for any warranted parts; and, such replacement parts must be obtained directly from a manufacturer's representative or RAE Corp. Claims for replacement parts obtained locally will be disallowed unless accompanied by a RAE Corp. purchase order for such replacement parts.

Orders for warranty replacement parts will be shipped ground transportation prepaid using the most appropriate transportation method.

Any premium transportation service will be at the cost of the requestor.

Export Equipment

Equipment exported outside the United States will be covered under the same parts only warranty as non exported equipment; provided that, all warranty transactions must take place within the territorial United States. Parts covered under warranty must be paid for in advance of any parts shipment. The customer will be reimbursed upon return of the warranty part and after the part has been inspected and determined defective. All exporting paperwork and shipping costs, including crating, will be the responsibility of the party ordering the part.

Initial Inspection

RAE Corp. will not be responsible for shipping damage, or for parts lost in transit, or for any claims of concealed damage. It is the responsibility of the receiving party to thoroughly inspect the equipment upon delivery for damage, or dry nitrogen pressure loss in transit, and to verify that any loose parts have been included in the shipment. The bill of lading will indicate if parts are shipped loose in the unit. If shipping damage has occurred, or loose parts are missing, the receiving party must resolve the issue through the claim process with the company responsible for transporting the equipment.

4. Notice to RAE Corporation

To contact and/or notify RAE Corporation Service Department the following contact information must be used:

Address: P.O. Box 1206, Pryor, OK 74362
Office Phone: 918-825-7222
After Hours Emergency Cell Phone: 918-633-2838
Fax: 918-825-6366
Email: service@rae-corp.com