

4

3

2

1

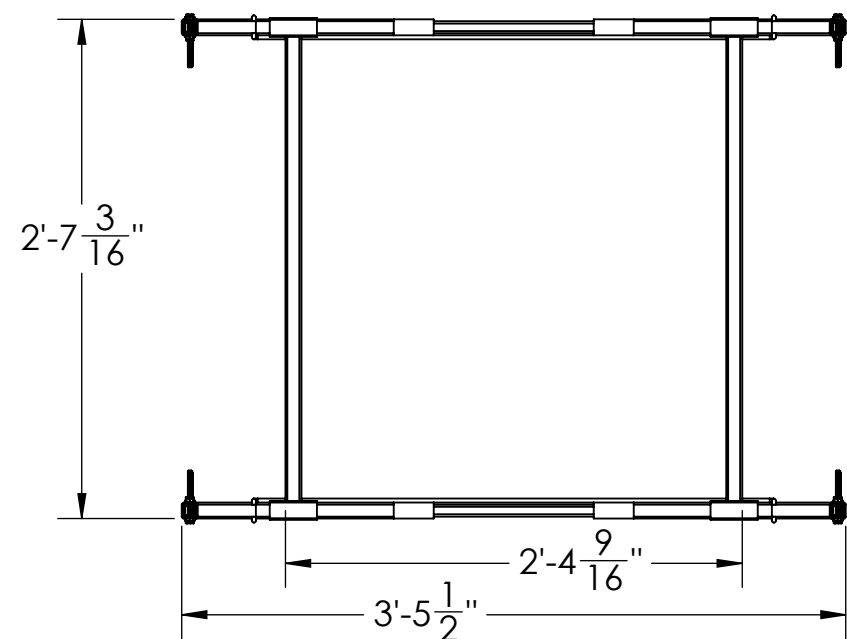

PLAN VIEW RETRACTED

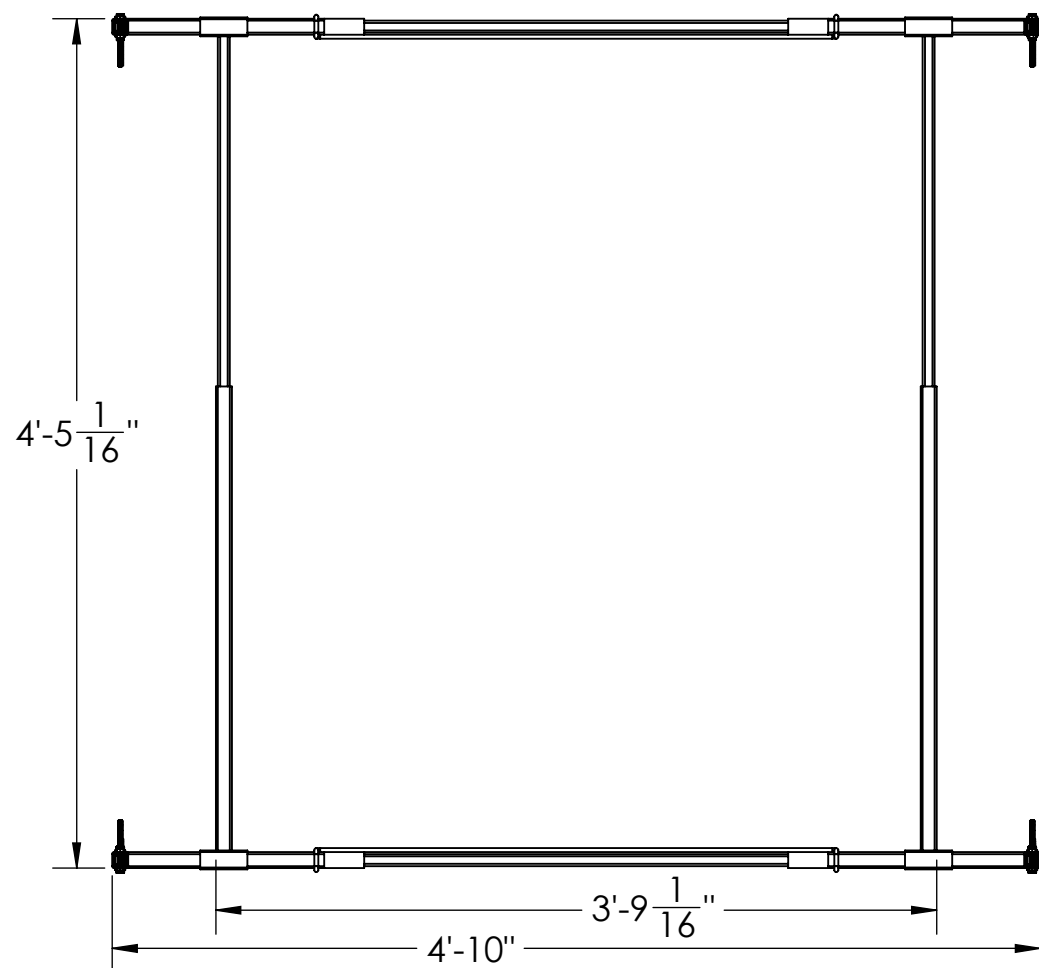

PLAN VIEW EXPANDED

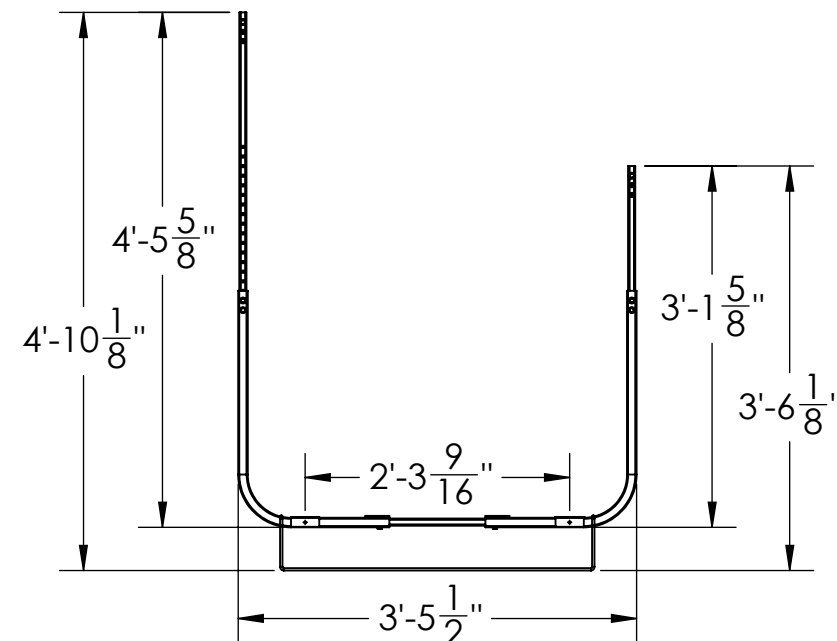

END VIEW RETRACTED

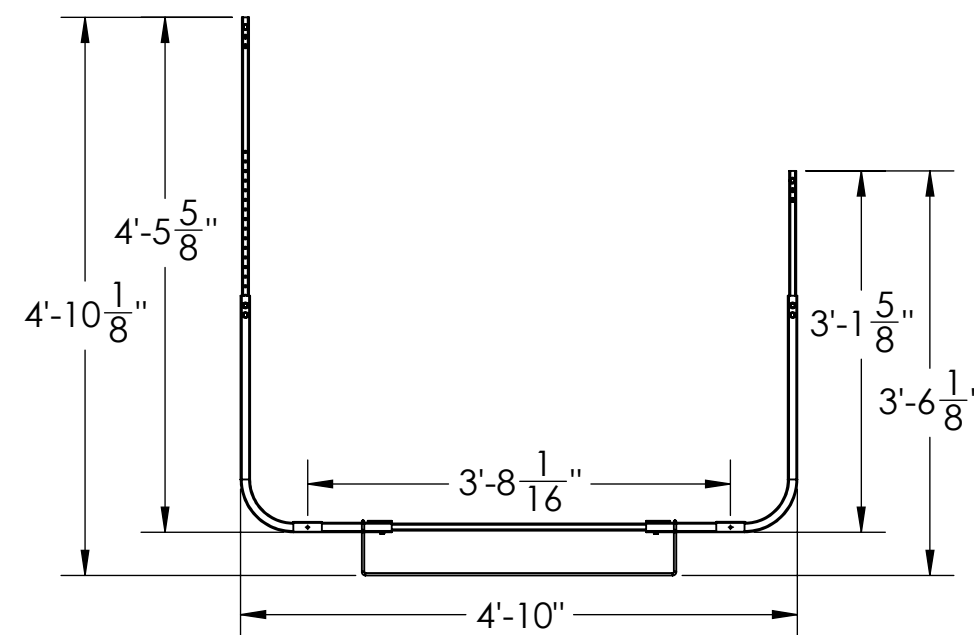

END VIEW EXPANDED

(*) - HEIGHT IS ADJUSTABLE IN 1" INCREMENTS UP TO 7".

IMPORTANT NOTE: THE INSTALLER IS RESPONSIBLE FOR THETHERING AND BOLTING UNITS TO WITHSTAND WIND AND/OR SEISMIC LOADS.

UNLESS OTHERWISE SPECIFIED:
 DIMENSIONS ARE IN INCHES [MILLIMETERS]
 TOLERANCES ARE: ANGLES ±1.0°
 FRACTIONAL SIZES X/Y ±1/64

INCHES	[MILLIMETERS]
X = ±0.1	[X = ± 2.5]
.XX = ±0.01	[.X = ± 1.3]
.XXX = ±0.005	[.XX = ±0.13]

THIRD ANGLE PROJECTION



CONFIDENTIAL - PROPRIETARY - DO NOT COPY THE INFORMATION SET FORTH IN THIS DOCUMENT AND RELATED INFORMATION IS THE CONFIDENTIAL PROPERTY OF DIVERSITECH CORPORATION, AND IS NOT TO BE COPIED OR REPRODUCED OR DISTRIBUTED IN ANY FORM WITHOUT PRIOR WRITTEN PERMISSION FROM DIVERSITECH CORPORATION. DO NOT SCALE DRAWING	MATERIAL: DWG. NO. Quick Swing - 2000 MODEL NO. QSLG-2000	WEIGHT GMS. REV.
	DESCRIPTION	SHEET 1 OF 2

4

3

2

1

B

A

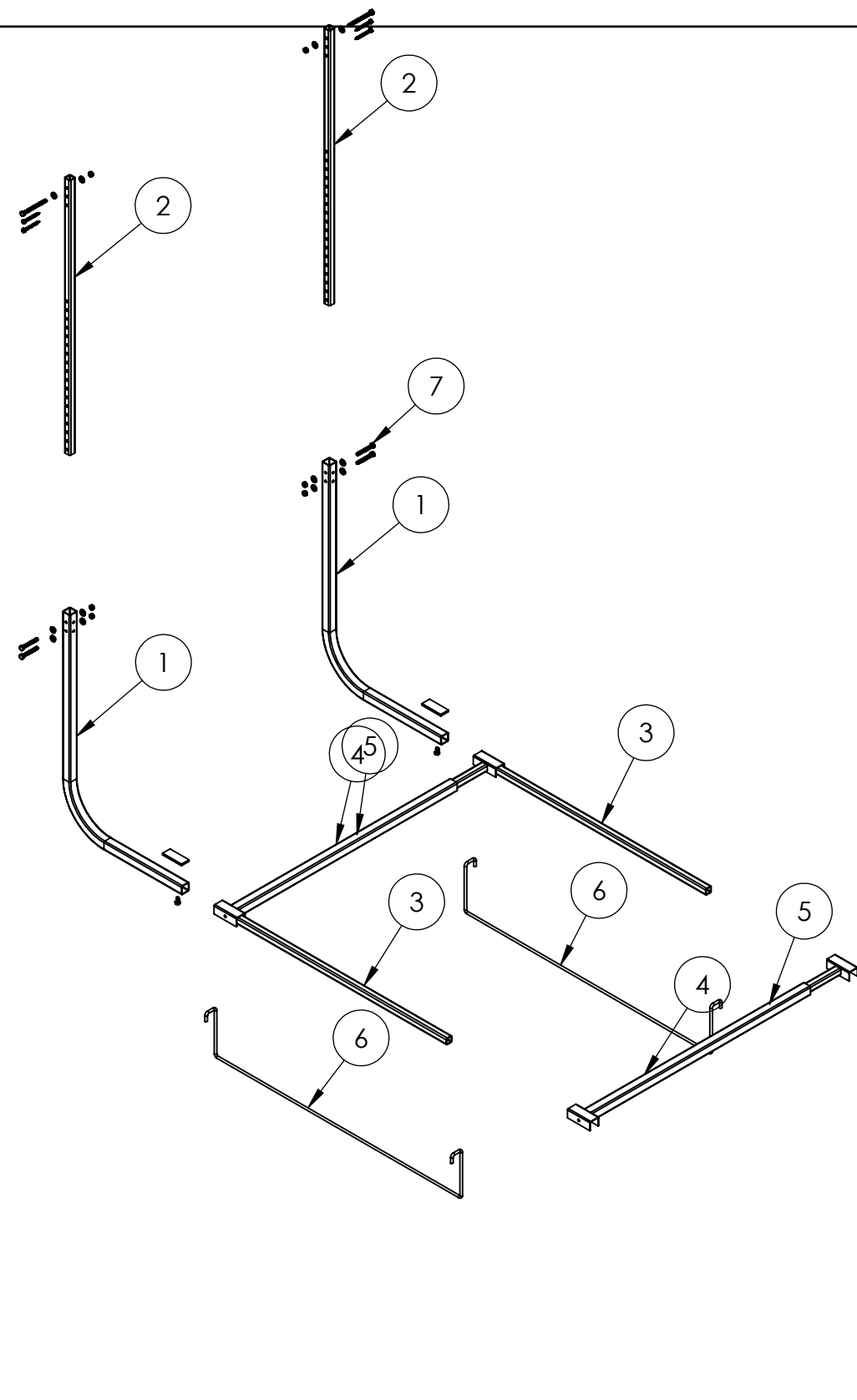

ITEM NO.	PART NUMBER	DESCRIPTION	Default/ QTY.
1	SL102	Sling Left/Right J-Bar	4
2	SL101	Sling Left & Right Hanger Arm	4
3	SL103	Sling Extension Bar	2
4	SL104	Sling 1in Tubing Arm w/ Saddle	2
5	SL105	Sling 3/4in Tbing Arm w/Saddle	2
6	SL106FAB	Stand Drain Pan Hanger	2
7	HDKLG03	Hardware Kit for QSLG2000	1

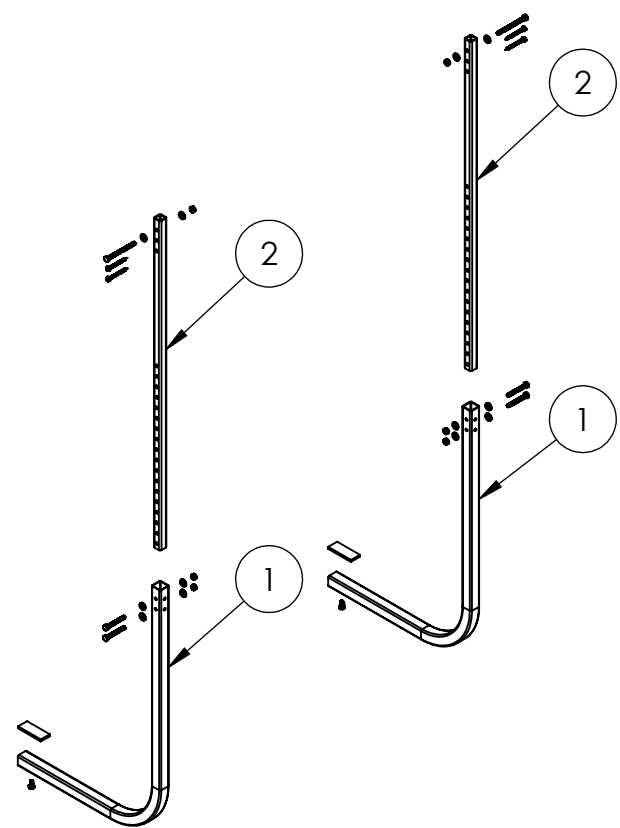

NOTE - ALL ASSEMBLY HARDWARE IS INCLUDED

UNLESS OTHERWISE SPECIFIED:
 DIMENSIONS ARE IN INCHES [MILLIMETERS]
 TOLERANCES ARE: ANGLES ±1.0°
 FRACTIONAL SIZES X/Y ±1/64

INCHES	[MILLIMETERS]
X = ±0.1	[X = ± 2.5]
.XX = ±0.01	[.X = ± 1.3]
.XXX = ±0.005	[.XX = ±0.13]

THIRD ANGLE PROJECTION



CONFIDENTIAL - PROPRIETARY - DO NOT COPY
 THE INFORMATION SET FORTH IN THIS DOCUMENT AND RELATED INFORMATION IS THE CONFIDENTIAL PROPERTY OF DIVERSITECH CORPORATION, AND IS NOT TO BE COPIED OR REPRODUCED OR DISTRIBUTED IN ANY FORM WITHOUT PRIOR WRITTEN PERMISSION FROM DIVERSITECH CORPORATION.
 DO NOT SCALE DRAWING

MATERIAL:
 DWG. NO. Quick Swing - 2000
 MODEL NO. QSLG-2000

WEIGHT
 GMS.
 REV.
 SHEET
 2 OF 2