

REVISIONS				
REV.	DESCRIPTION	DRAWN BY	APPR BY	APPR DATE

***ALL DIMENSIONS SHOWN ARE FINAL DIMENSIONS POST DIP**

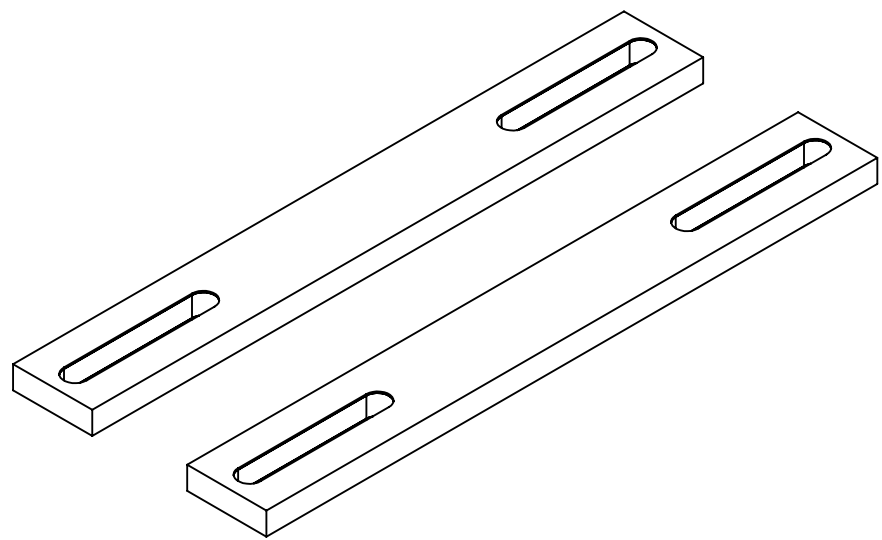
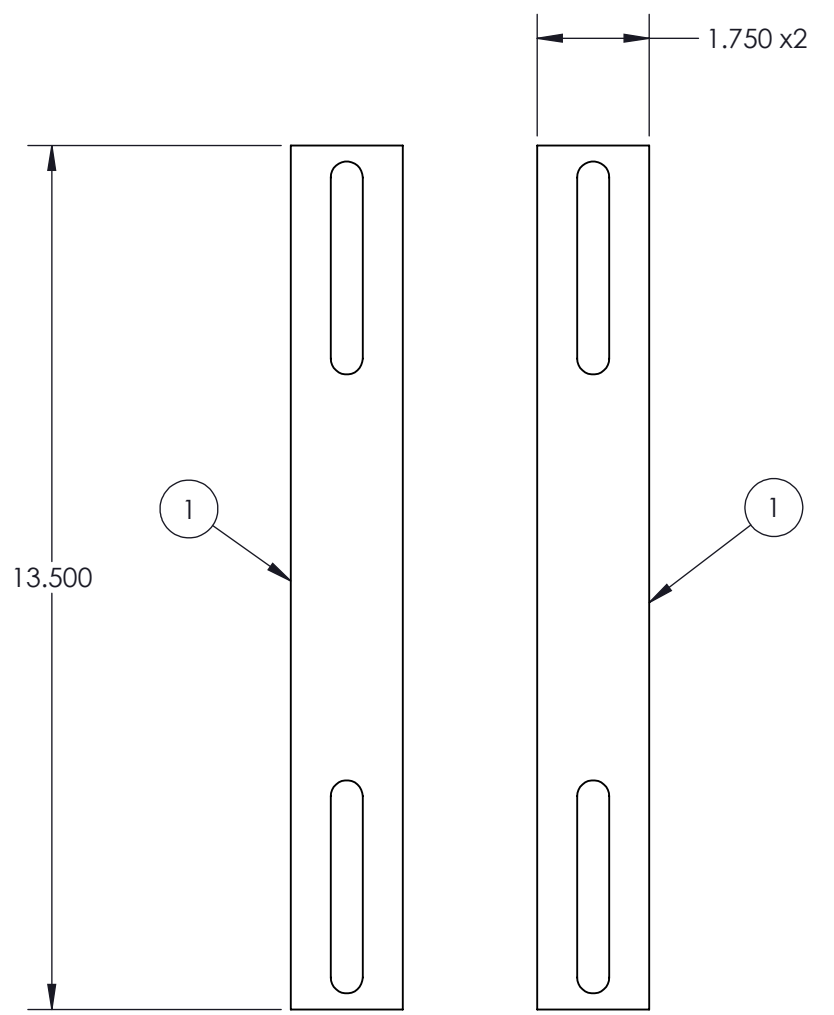

ITEM NO.	PART NUMBER	DESCRIPTION	QTY.
1	AC510	VIBRATION ISOLATION KIP-RT FOR QSMS1200	2

ALL DRAWINGS AND WRITTEN MATERIAL CONTAINED HEREIN ARE THE PROPERTY OF DIVERSITECH CORP AND MAY NOT BE DUPLICATED OR DISCLOSED AT ANY TIME UNLESS APPROVED IN WRITING BY DIVERSITECH CORP INTERPRET THIS DRAWING IN ACCORDANCE WITH ASME Y14.5-2009 DIMENSIONING AND TOLERANCING STANDARDS	UNLESS OTHERWISE SPECIFIED DIMENSIONS & TOLERANCES ARE IN INCHES		DEBURR ALL SHARP EDGES *DO NOT SCALE* THIRD ANGLE PROJECTION			TITLE		SIZE
	DIM RANGE	TOLERANCE				KIP-RT Kinetics Noise Control		B
				0.02 - 0.12	±0.008	DRAWING NUMBER	REVISION	
	0.12 - 0.24	±0.012		DRAWN BY: apadilla		DATE: 8/28/2019	QSAC5100	
0.24 - 1.18	±0.020	CAD APPR.			SCALE: 1:1		SHEET 1 OF 2	
1.18 - 4.72	±0.031	DWG APPR.						
4.72 - 15.75	±0.047							
15.75 - 39.4	±0.079							
39.4 +	±0.118							

NOTES:

1. MATERIAL: FIBER GLASS
2. COLOR: GREEN OR BLACK
3. FINISH: CURED RESIN
4. LOAD: BEST IF USED BETWEEN 2.5 PSI AND 15 PSI

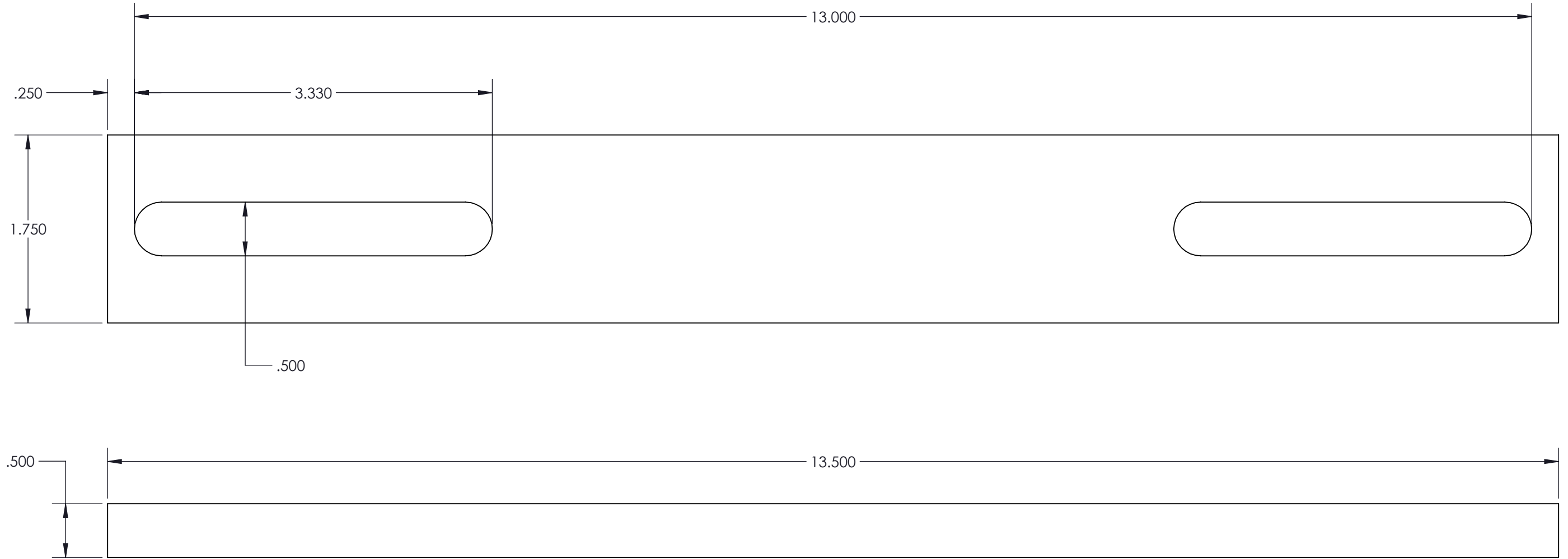

ALL DRAWINGS AND WRITTEN MATERIAL CONTAINED HEREIN ARE THE PROPERTY OF DIVERSITECH CORP AND MAY NOT BE DUPLICATED OR DISCLOSED AT ANY TIME UNLESS APPROVED IN WRITING BY DIVERSITECH CORP

INTERPRET THIS DRAWING IN ACCORDANCE WITH ASME Y14.5-2009 DIMENSIONING AND TOLERANCING STANDARDS

DEBURR ALL SHARP EDGES
DO NOT SCALE

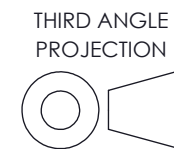

TITLE			SIZE
KIP-RT kit for QSMS1200			B
DRAWING NUMBER	REVISION		
QSAC5100			
SCALE: 1:4			SHEET 2 OF 2