

Installation, Maintenance and Operating Manual Instruction for
PV Pneumatic Actuators

CONTENTS

- 1) GENERAL
- 2) WARNING
- 3) WORKING CONDITIONS AND TECHNICAL DATA
- 4) OPERATING FUNCTION AND DIRECTION OF ROTATION
- 5) ACTUATOR INSTALLATION INSTRUCTION
- 6) MAINTENANCE INSTRUCTION
- 7) STORAGE INSTRUCTION
- 8) SIZE CHART OF VT PNEUMATIC ACTUATORS

1) GENERAL

This instruction manual contains important information regarding the installation, operation, maintenance and storage for VT pneumatic actuators. Please read these instructions carefully and save them for future reference. It is important that the use and that only property trained personnel disassemble/assemble the actuator.

2) WARNING

- Do not operate the actuator using inflammable, oxidising, corrosive, explosive and unstable gases or liquids. For actuators installed in potentially explosive zones, make sure that the internal parts of the actuator cannot come into contact with the external atmosphere.
- It is important that the actuator should only be used within pressure limits indicated in our technical specifications.
- Operating the actuator over pressure limits will damage internal parts as well as cause damage to the housing.
- Operating the actuator over temperature limits will damage internal components (disassembly of spring return actuator may become dangerous).
- Operating the actuator in corrosive environments with incorrect protection may damage the internal and external parts.
- Do not disassemble individual spring cartridges. Disassembly may result in personal injury. For further information contact Vtork.
- Isolate all air lines and make sure that actuator while the actuator is pressurised.
- Do not remove end caps or disassemble the actuator while the actuator is pressurised.
- Before installing onto a valve make sure that the rotation of the valve and the actuator are the same and that the position indicator orientation is also correct.
- If the actuator is incorporated in a system or used within safety devices or circuits, the customer shall ensure that the national and local safety laws regulations are observed.

3) WORKING CONDITIONS AND TECHNICAL DATA

- Operating media:
Dry or lubricated air or inert/non-corrosive gases provided they are compatible with internal actuator parts and lubricant. The operating media must have a dew point equal -20°C or at least 10°C below the ambient temperature. The max particle size must not exceed 30 µm.
- Supply pressure:
Generally for Double Acting and Spring Return actuator the supply pressure is: from 2.5Bar (36 PSI) min. to 8 Bar (116 PSI) max.
- Operating Temperature:
Standard product from -15°C (-5°F) to +80°C (+176°F).
Low temperature LT actuator with silicon "O" rings from -40°C (-40°F) to +80°C (+176°F).
High temperature HT actuator with FPM "O" rings from -15°C (-5°F) to +150°C (+300°F).
Caution: For low and high temperature service, special grease is required. Please contact Vtork for each application. High and low temperature will vary the output torque of the actuator.
- Stroke:
The stroke for VT actuators is as follows (See technical data):
Standard construction: 90° rotation with stroke adjustment at 0° and 90°±5°.
- Lubrication:
The actuators are factory lubricated for the life of the actuator in normal working conditions.
The standard lubricant is suitable for use from -15°C (-5°F) to +80°C (+176°F).
- For low (LT) and high (HT) temperature service, where special grease is required please contact Vtork.
- Valve installation:
Pneumatic actuators can be directly connected with the valve, the valve can also be connected via a bracket, and the manual mechanism can be installed between valve and pneumatic actuator. The bottom of actuator is in accordance with ISO5211 standard threaded holes for connection, and can choose one two kinds of standards. Adjusting bolt should be tightened to prevent loosening. The lower end of the output shaft has two square holes for valve shaft side in both directions, connection gap should be minimized in order to improve sensitivity and reduce hysteresis.
Pneumatic actuator air supply connection thread hole with 3 standard sizes: 1 / 8 "NPT, 1 / 4" NPT, 1 / 2 "NPT, detailed specifications refer to the corresponding technical manuals related information.
Please pay attention to ventilation identify the direction of the output shaft clockwise or counterclockwise rotation. Under normal circumstances, the valve should be closed in clockwise direction, valve opening is in counter-clockwise direction.
- Pneumatic actuator adjustments
Each pneumatic actuator in factory has to undergo rigorous adjustment, pressure test and performance tests, normally; users do not need to make adjustments and testing.
Connected with the valve, if the valve open or closed position needs to be adjusted, there are two adjustment screws upper the end of the cylinder, 0° and 90° position can be adjusted to ± 4°.

4) OPERATING FUNCTION AND DIRECTION OF ROTATION

The actuator is a pneumatic operator for remote actuator of valves.

The rotation of type "D" actuator is clockwise to close, counter-clockwise rotation is obtained when port 2 is pressurised. The rotation of type "S" is clockwise to close, counter-clockwise rotation is obtained when port 2 is pressurised.

Air supplied to port 2 forces the pistons apart and toward end positions, compressing the spring with exhaust air exiting at port 4, a counter clockwise rotation is obtained.

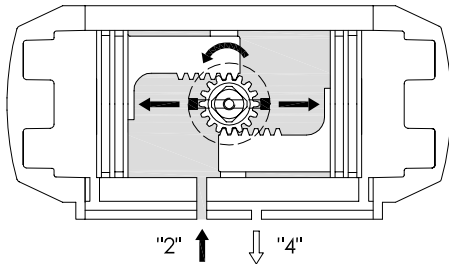

Air supplied to Port 4 forces the pistons together with exhaust air exiting at Port 2, a clockwise rotation is obtained.

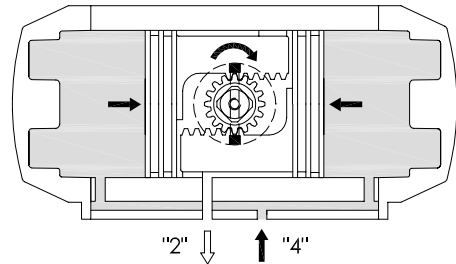

Air supplied to Port 2 forces the pistons apart and toward end positions, with exhaust air exiting at Port 4, a counter-clockwise rotation is obtained.

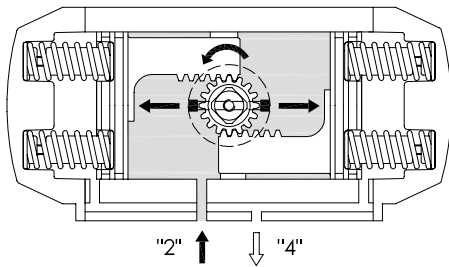

On loss of air pressure (air or electric failure) at Port 2 allow the springs to force the pistons to the position with exhaust air exiting at Port 2, a clock-wise rotation is obtained.

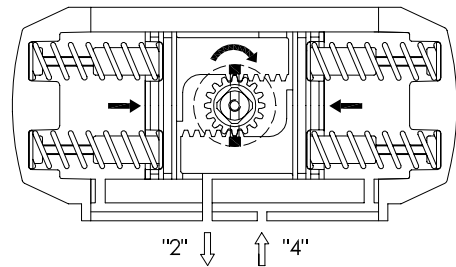

5) ACTUATOR INSTALLATION INSTRUCTIONS

The VT actuator is a pneumatic device for the remote operation of industrial valves.

All the necessary technical information to install the actuator correctly and safety onto a valve i.e.

Model/Type, ENISO 5211/Square, Max, Operating Pressure, Torque at 5.5bar, Operating temperature, Pressure Connection. Please read this technical information carefully before proceeding with the actuator installation.

5.1) Important Safety Notice:

- The actuator must not be pressurized at any time during installation as injury may result.
- The utmost cleanliness is required during air supply connection to the actuator i.e. the connecting pipe thread, fittings and seals must be clean and dirt-free.
- When fitting accessories onto the actuator assemble them in such a way that the top of the drive shaft is easily accessible should manual operation of the actuator be required.

5.2) Controls and connections, Figure A:

5.3) Assembly of accessories: Solenoid valves and Switchboxes Figure B:

- Solenoid valve mounting:
Before mounting a Solenoid valve ensure that the actuator is in its normal position (closed position) pistons together:
- Fit the solenoid valve 4 onto the actuator 3 using the screws provided (max. tightening torque see the table below).

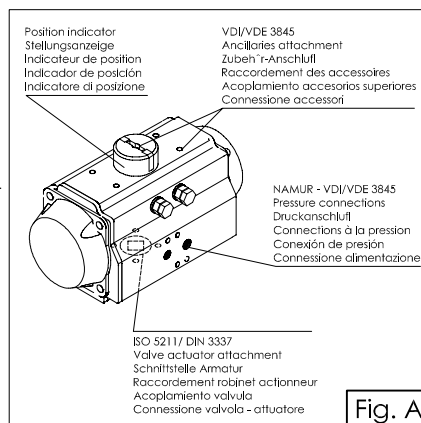

Fig. A

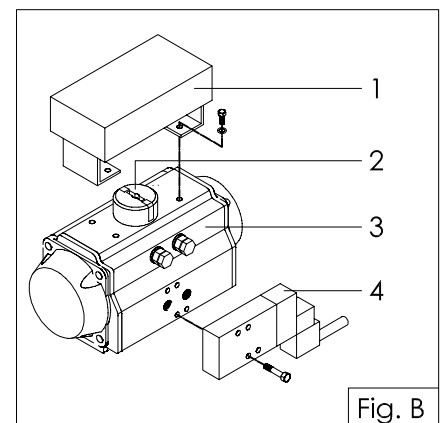

Fig. B

5.4) Assembly of valve Figure C:

Before proceeding with the assembly of a valve onto an actuator be sure that the actuator operates in the desired direction of rotation and both actuator/valve are correctly orientated.

Important: When using a spring return actuator for a fail safe operation, ensure that when air or electricity failure occurs the direction of rotation is correct for your application.

Fit the valve 5 onto the actuator 3. Ensure that the actuator is in normal position (closed position).

There are two types of valve assembly onto the actuator:

- Direct-mount: Fit the square of the valve 5 directly into the square of the actuator 3 and bolt together through the valve ISO pad (max. tightening torque see table below).
- Bracket-mount: Mounting with a bracket 6 and coupling 7, the bracket is bolted to the actuator/valve to join them together and coupling is used to connect the actuator output drive to the valve stem (max. tightening torque see table).

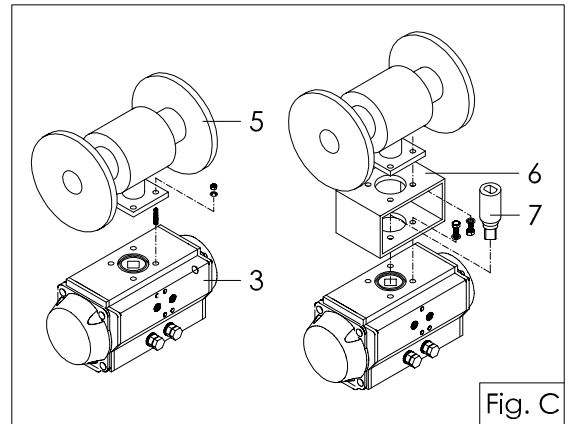

Fig. C

5.4.1) Mounting alternatives:

5.4.2) Valve mounting with PV Type D (closewise to close) Figure D

5.4.3) Valve mounting with PV Type S (closewise to close) Figure E

Tightening Torque Table	
M..	Nm
M5	5-6
M6	10-11
M8	23-25
M10	48-52
M12	82-86
M14	132-138
M16	200-210
M20	390-410
M24	675-705
M30	1340-1400

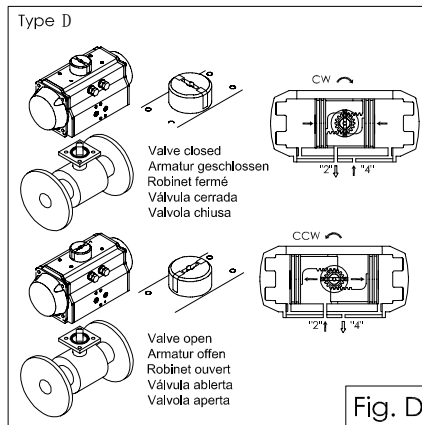

Fig. D

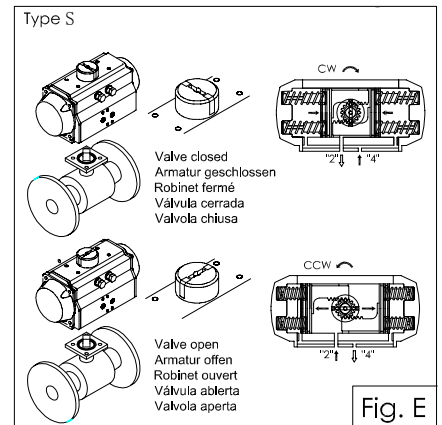

Fig. E

6) MAINTENANCE INSTRUCTION

With the information given below, PV provides the end user with all the required information necessary for maintenance. Under normal operating conditions the actuator requires only periodic observation to ensure proper adjustment.

Rebuilding of the Vtork actuators is allowed only to the personnel of Vtork or to personnel which are properly instructed. By contravention the guarantees expires!

Spare kits for maintenance are available to replace all seals and bearings (Soft components listed in table) that may be necessary between 300,000 and 1,000,000 cycles depending on operating and/ or environmental conditions and actuator size.

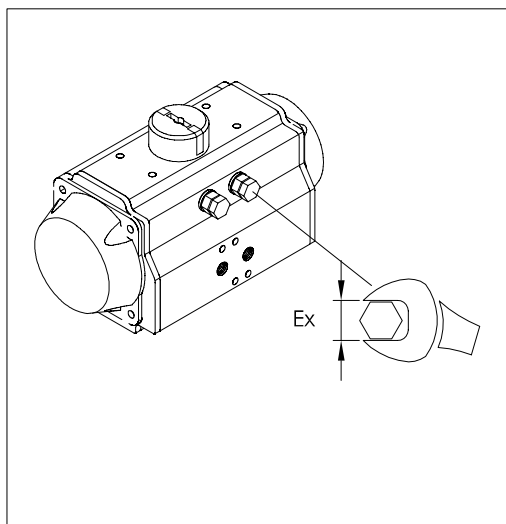

Model	EX mm
PV032	8
PV050	10
PV065	10
PV075	13
PV085	13
PV095	16
PV110	16
PV125	18
PV140	18
PV160	21
PV190	21
PV210	24
PV240	30
PV270	30
PV300	36
PV350	46
PV400	55

6.1) Drawing with itemised component spare parts

Part No	UNIT Q.TY	PART DESCRIPTION
01	1	Cap screw
02	1	Position indicator
03	1	Spring clip
04	1	Thrust washer
05	1	Thrust bearing
06	1	Body
07	2	Piston
08	0-12	Spring
09	2	"O"ring (end cap)
10	8	Cap screw (end cap)
11	2	End cap
12	2	Bearing (piston head)
13	2	"O"ring (pinion)
14	2	Wear band
15	2	stop cap screw
16	2	Nut (stop screw)
17	2	Washer (stop screw)
18	2	"O" ring (stop screw)
19	1	"O" ring (pinion top)
20	1	Bearing (Piston top)
21	1	Thrust bearing (pinion top)
22	1	OCTI-CAM
23	1	Drive shaft
24	1	Bearing (pinion bottom)
25	1	"O"ring (pinion bottom)
26	2	Plug

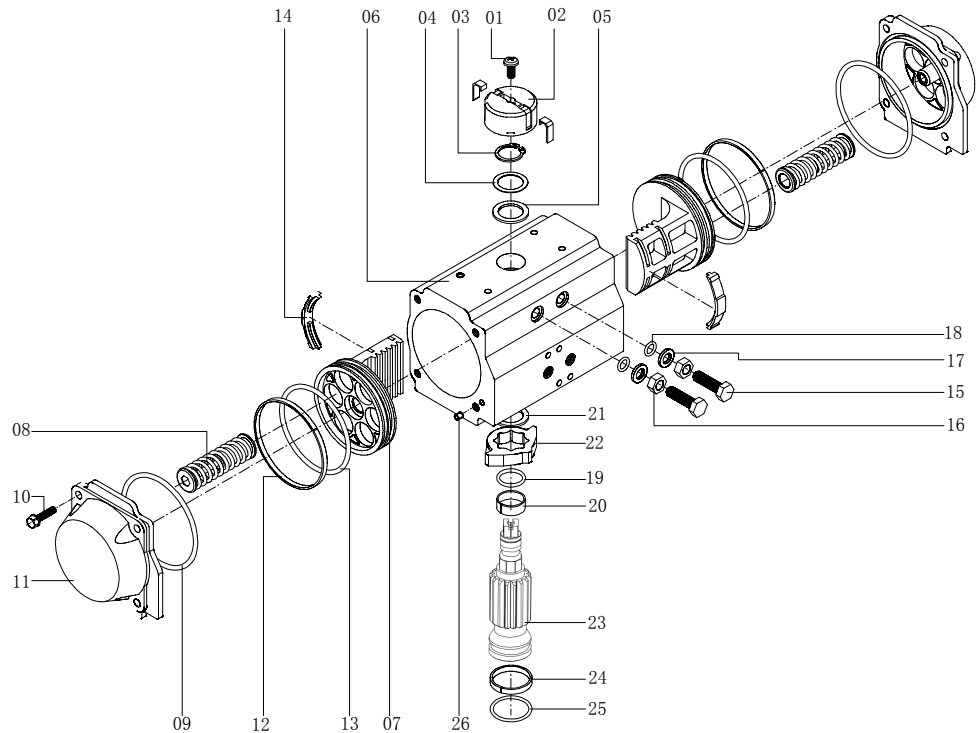

6.2) Disassembly

- When disassembly of actuator is required for maintenance, firstly remove the actuator from the valve.
- Before performing any disassembly operations it is important to verify that the actuator is not pressurised.
- Always use caution and double check that the port 2 and 4 are vented and are free from any accessory and/or device. When the actuator is a spring return unit, make sure that the actuator is in the failed position before disassembling.

A) Removal of position indicator (Part NO.02),figure 01:

- Remove cap screw(01)if fitted.
- Lift position indicator (02) off shaft, it may be necessary to pry gently with a screwdriver.

B) Removal of stop cap screw (Part NO.15),figure 02:

- Remove both stop cap screws together with the nut (16)and washer (17).
- Remove stop screw O-rings (18)and discard if replacing all soft parts.

C) End caps disassembly (Part NO.11),figure 03:

- Remove cap screw (End cap 10)in the sequence shown in the figure 03.Caution: when disassembling a spring return actuator, the end cap should be loose after unscrewing end cap bolts (10) 4-5 turns. If there is still force on the end cap after 4-5 turns of the cap bolts, this may indicate a damaged spring cartridge and any further disassembly should be discontinued. Further disassembly of the end cap may result in injury. Return actuator to Vtork for further maintenance.

- For spring return actuators, always remove spring cartridge.
- Remove end cap O-rings (09)and discard if replacing all soft componts.

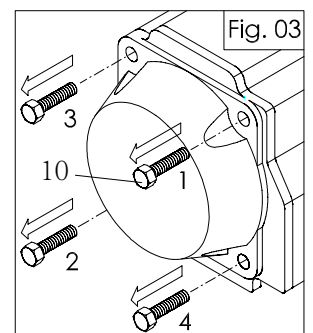
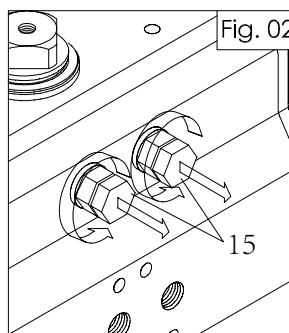
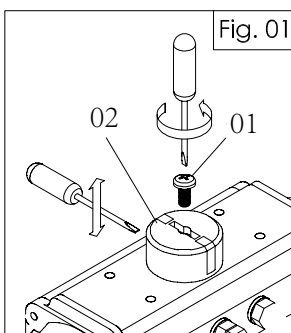

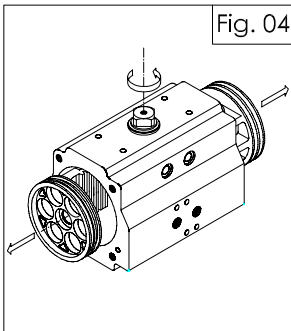

Fig. 04

D) Pistons disassembly (Part NO.07),figure 04:

- Holding the body (06) in a vice or similar device, rotate the drive shaft (23) until the pistons (07) are released. Caution: Air pressure should not be used to remove the pistons from the body.
- Remove piston "O" rings (13) using a small screwdriver; remove the piston back (14) and piston head (15) bearings. Discard bearings when replacing all soft components.

E) Pinion shaft disassembling (Part NO.23), figure 05:

- Remove spring clip (03) carefully, using nap-ring pliers, remove external thrust bearing (05) and thrust washer (04).
- Apply downward force to top of drive shaft (23) until it is partially out of the bottom of the body when it is possible to remove the octi-cam (22) and internal thrust bearing (05), then push the pinion (23) completely out of the bottom of the body. If pinion does not remove freely gently tap the top of the shaft with a plastic mallet.
- Remove top and bottom pinion bearings (20) and (24) and top and bottom pinion O-rings (25) and (19).
- Discard bearings (20) and (24), internal and external thrust washer (05) and O-rings (25) and (19) if replacing all soft components. When all components are disassembled, those not being replaced should be properly cleaned and inspected for wear prior to being greased and re-assembled.

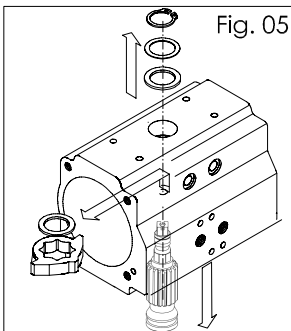

Fig. 05

6.3) Assembly:

- Prior to assembly, ensure all components are perfectly clean and free from damage. Please see point 3 for recommended lubricants.

A) Drive shaft assembly (part NO.23), figures 06 and 07

- Install top and bottom pinion bearings (20) and (24) and top and bottom pinion O-rings(25) and (19) onto the shaft.
- Grease the outside surface of the drive shaft on top and bottom as shown in figure 06.
- Insert partially the drive shaft (23) in the body (26), install octi-cam (22) in the correct position as shown in figure 07 related to the bottom and top of the drive shaft. and rotation of the actuator when energised and install internal thrust bearing (05). Insert completely the drive shaft in the body.
- Fit external thrust bearing (05), thrust washer (04) and then external circlip (03) using snap ring pliers.

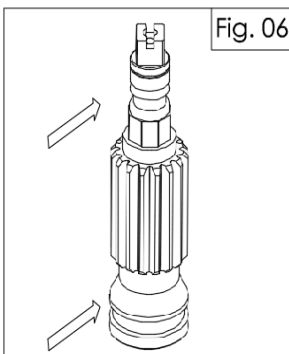

Fig. 06

B) Pistons assembly (Part NO.07), figure 08,09,10 and 11:

- Install piston O-rings (13), the piston skirt (14) and piston head (12) bearings.
- Grease the internal surface of the body (06) and the piston (07) rack teeth.
- Hold the body (06) in a horizontal position by inserting the top of the shaft into a vice or the bottom of the shaft connection into a male drive fitted in a vice as shown in figure 08.
- Ensure that the octi-cam is in the right position as shown in figure 09.
- For standard rotation assembly (clockwise to close) rotate the body (06) about 0-90° counter-clockwise from bottom view or clockwise from top view depending on which way the shaft has been linked as shown in figure 10.
- Press the two pistons (07) simultaneously inside the body (06) until the pistons are engaged and rotate the body clockwise from bottom view or counter clockwise from top view until the stroke is completed.
- Ensure that when the pistons are inserted that they both mesh at the same time. Check fully closed and open positions as shown in figure 11.

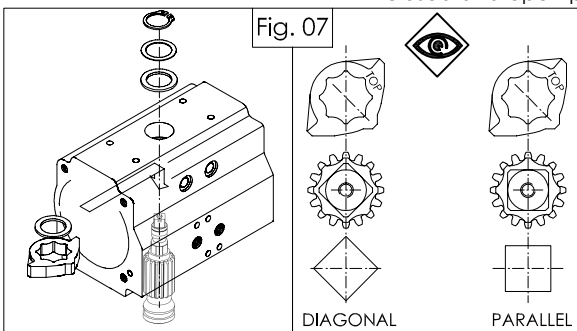

Fig. 07

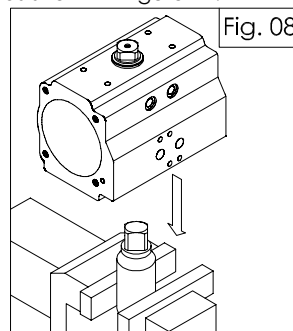

Fig. 08

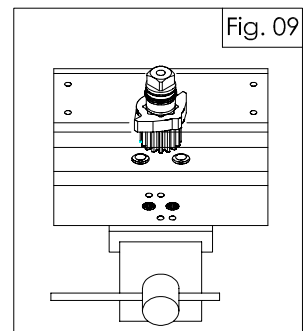

Fig. 09

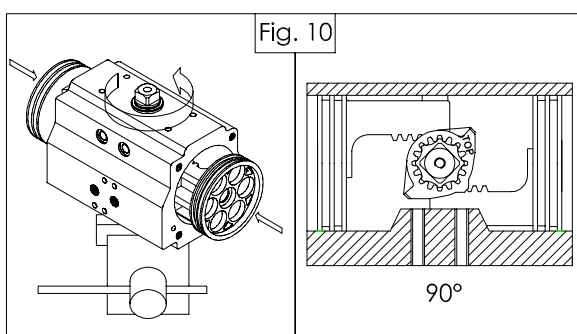

Fig. 10

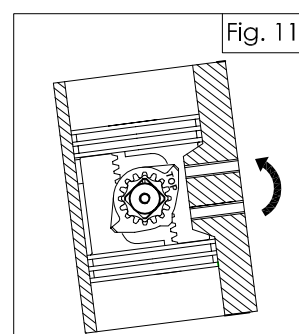

Fig. 11

C) End cap (Part NO.11) and spring cartridge (Part NO.08) assembly, figure 12,13,14:

- Lubricate the body.
- For spring return actuator insert the proper quantity of spring cartridge according to the pattern shown in figure 12 (referring to the total number of springs). Insert spring cartridge (08) as shown in figure 13.
- Fit end cap O-ring seal (09) into the groove in the end cap, on both end caps.
- Fit end caps onto the body (06), verifying that the O-ring remains in the groove.
- Insert all the cap screws (10) and tighten each only partially. Complete tightening by following the sequence indicated in figure 14.

D) Assembly of stop cap screws (Part NO.15), and stroke adjustment figure 15:

- Insert on both the stop cap screw (15), the nut (16), the washer (17), and the O-ring in (18).
- Fit the stop cap screw (15) in the body. Stroke adjustment for standard rotation actuator (clockwise to close):
- 0° (close) position stroke adjustment with actuator in close position, screw or unscrew the right (from top view) stop mcap screw(15) until the desired stop position is achieved. Then tighten the stop adjustment nut (16) to lock it in place.
- 90° (open) position stroke adjustment with actuator in open position, screw or unscrew the left (from top view) stop mcap screw(15) until the desired stop position is achieved. Then tighten the stop adjustment nut (16) and lock it in place.

E) Assembly of position indicator (part NO.02 and 01), figure 16:

- Fit position indicator (02) on the shaft verifying that it indicates the correct actuator position.
- Then fit cap screw (01) where fitted.

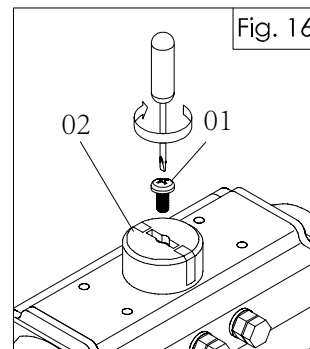
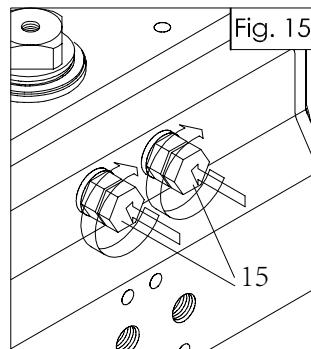
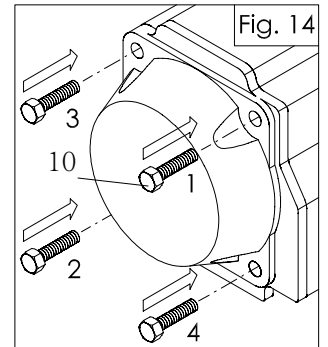
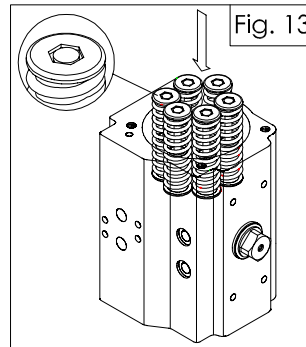
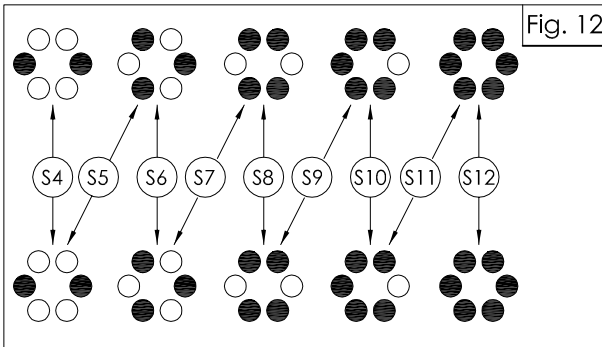

7) STORAGE INSTRUCTIONS

If the actuators are not for immediate use, the following precaution must be taken for storage:

- Store in a dry environment at ambient temperature.
- It is recommended that the actuator be stored in its original box.
- Do not remove the plastic plugs on air supply ports.