

Honeywell



# 3 Nm Series Spring Return Direct Coupled Actuators

MS7103, MS7503



## INSTALLATION INSTRUCTIONS

MS7103, MS7503 Spring Return Direct Coupled Actuators (DCA) are used within heating, ventilating, and air-conditioning (HVAC) systems. They can drive a variety of quarter-turn, final control elements requiring spring return fail-safe operation.

Applications include:

- Volume control dampers, mounted directly to the drive shaft or remotely (with the use of accessory hardware).
- Quarter-turn rotary valves, such as ball valves mounted directly to the drive shaft.
- Available with cable on all models
- Fast test mode

## SPECIFICATIONS

**Models:**

- See Table 1.

**Device Weight:**

- 1.7lbs (0.78 kg)

**Ambient Operating Temperature:**

- 40° to 150°F (-40° to 65°C)

**Shipping and Storage Temperature:**

- 40° to +150°F (-40° to +65°C)

Table 1. Models.

Model Number	Control Input / Output Description	SPST Aux Switches	1/2" 360° Conduit	Shaft Adaptor	Torque	Supply Voltage	Driving/Holding (VA)	Drive (sec)
MS7103A1021	Modulating (1)	No	Yes	SCSA	27 lb-in (3Nm)	24 VAC +/-20% @ 50/60 Hz class 2 transformer, 24 VDC +20%/-10%	4/2	90
MS7103A2021	Modulating (1), Feedback	No	Yes					
MS7103A2221	Modulating (1), Feedback	Yes	Yes					
MS7503A2021	Modulating (2), Floating, Feedback	No	Yes					
MS7503A2221		Yes	Yes					
MS7103A2024	Modulating (1), Feedback	No	No	U-Bolt				
MS7103A2224		Yes	No	U-Bolt				

<sup>1</sup> 2-10 VDC

<sup>2</sup> 0(2)-10 VDC, 10-0(2) VDC



31-00141M-03

**Humidity Ratings:**

- ☐ 5% to 95% R.H., Non-Condensing

**Auxiliary Switches (Two SPST):**

- ☐ Fixed switches on 10 and 80 degrees
- ☐ 125 VAC, 1A, res. load

**Mounting: Self-Centering Shaft Adapter (Shaft Coupling):**

- ☐ Round damper shafts: 3/8 to 5/8 in. (9 to 16 mm)
  - ☐ Square damper shafts: 1/4 to 1/2 in. (6 to 13 mm)
- Nominal tightening torque for self-centering shaft adapter screw is 106 lb-in (12Nm).

**Non Self-Centering Shaft Adapter:**

- ☐ Round damper shafts: 1/4 to 3/4 in. (6 to 19 mm)
  - ☐ Square damper shafts: 1/4 to 1/2 in. (6 to 13 mm)
- Nominal tightening torque for non self-centering shaft adapter screw is 62 lb-in (7Nm).

**Minimum Damper Shaft Length:**

- ☐ 3.25 in. (83 mm) recommended for self-centering adapter.

**Spring Return Timing (at Rated Load):**

- ☐ < 25 seconds @ -22°F to 150°F (-30°C to 65°C)
- ☐ < 60 seconds @ -40°F to -22°F (-40°C to -30°C)

**Cable Specification:**

- ☐ Power Cable: Plenum Rated, 3 ft (0.914 m) length from end of access cover, 18 AWG
- ☐ Switch Cable: Appliance Rated, 3 ft (0.914 m) length from end of access cover, 18 AWG

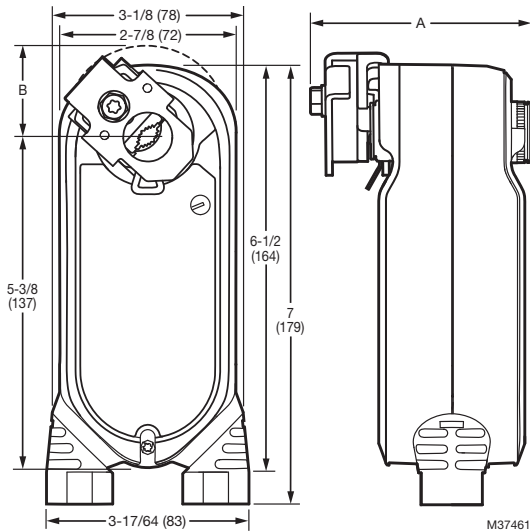
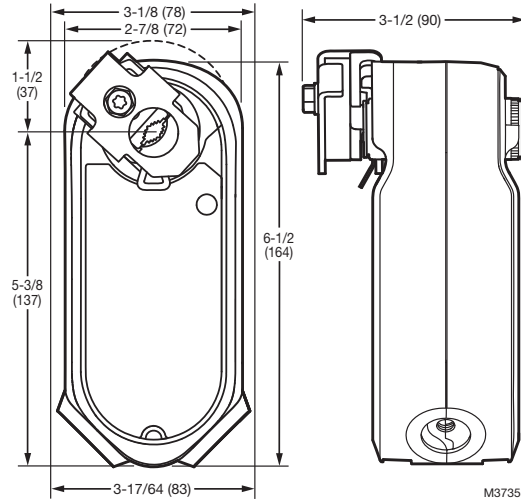

**Fig. 1. Dimensional drawing of actuator in in. (mm). See Table 2 for A and B dimensions.**

**Table 2. Shaft Adapters.**

Type of Shaft Adapter	A	B
Self-Centering Adapter	3.54 in. (90 mm)	1.54 in. (39 mm)
Non Self-Centering Adapter	3.11 in. (79 mm)	1.57 in. <sup>1</sup> (40 mm)

<sup>1</sup>For 1/2 shaft



**Fig. 2. Dimensional drawing of actuator without conduit in in. (mm).**

**Stroke:**

- ☐ 95° ±3°, mechanically limited.

**Approvals:**

- ☐ UL60730
- ☐ IEC 60730-1 and Part 2-14
- ☐ UL1097 for Double Insulation
- ☐ CE Certification Low Voltage Directive 2014/35/EU
- ☐ CE EMC 2004/108/EC
- ☐ Switch cables are UL certified only

**Waste Electrical and Electronic Equipment (WEEE):**



Correct disposal of this product (applicable in the European Union and other European countries with separate collection systems). This product should be disposed of, at the end of its useful life, as per applicable local laws, regulations, and procedures.

**Enclosure Ratings:**

- ☐ IP54, depends on position according to “Determine Appropriate Mounting Orientation” on page 3.
- ☐ NEMA 2
- ☐ Flame Resistance UL94-5VA
- ☐ UL2043, switch wiring dependent on conduit installation

**Input Impedance:**

- ☐ 95 kOhm minimum for analog modulating input.

**Feedback Signal:**

- ☐ 2-10 VDC, 1 mA source, 0.5 mA sink

**Noise Rating at 1m Driving (Maximum at 90s drive speed):**

- ☐ Floating/Modulating < 40 dB(A)
- ☐ Spring Return: < 65 dB(A)

**Accessories and Ordering Information:**

- ☐ Wall Mount Kit
- ☐ Crank Arm Kit, OS-No. DIAM-CRK-01
- ☐ Self Centering Shaft Adapter
- ☐ Anti-Rotation Bracket

## TYPICAL SPECIFICATION

Spring return actuators shall be direct coupled type requiring neither crankarm nor linkage and be capable of direct mounting to a jackshaft of up to 3/4 in. diameter. The actuator shall connect to the shaft using a removable output hub with a self-centering shaft coupling. This coupling shall provide concentric mounting and include an integral adjustable range-stop mechanism.

The actuator shall provide floating and proportional control. Proportional control refers to direct acceptance of 0-10 VDC, 2-10 VDC, or (with addition of a 500 ohm resistor) a 4-20 mA input signal. Some proportional and floating control models shall provide a feedback signal. Floating actuators shall have a rotation direction control switch accessible on the cover.

All spring return actuators must be designed for either clockwise or counterclockwise fail-safe operation with a continuously engaged mechanical spring. This spring must return the valve or actuator to a fail-safe position within 25 seconds of power loss.

All actuators shall be designed for a minimum of 60,000 fullstroke cycles at rated torque and temperature, 60,000 spring return cycles and 1,500,000 repositions. Run time shall be constant and independent of: load, temperature, and supply voltage (within specifications). All actuators shall be UL60730 and cUL (CSA22.2) listed, have a five year warranty, and be manufactured under ISO 9001 International Quality Control Standards. Actuators shall be as manufactured by Honeywell.

## INSTALLATION

### When Installing this Product...

1. Read these instructions carefully. Failure to follow them could damage the product or cause a hazardous condition.
2. Check the ratings given in the instructions and on the product to make sure the product is suitable for your application.
3. Installer must be a trained, experienced service technician.
4. After installation is complete, check out product operation as provided in these instructions.

**CAUTION**  
**Electrical Shock or Equipment Damage Hazard.**  
**Low voltage can shock individuals or short equipment circuitry.**  
 Disconnect power supply before installation.

**IMPORTANT**  
*All wiring must comply with applicable codes, ordinances and regulations.*

### Location

These actuators are designed to mount directly to a damper external drive shaft. The shaft coupling fastens to the drive shaft. The actuator housing includes slots which, along with an anti-rotation bracket, secure the actuator to the damper frame or duct work (see Fig. 9).

- NOTES:
- When mounted correctly, these slots allow the actuator to *float* without rotating relative to the damper shaft.
  - Using other brackets or linkages, the actuator can be foot-mounted or tandem-mounted.

**CAUTION**  
**Motor Damage Hazard.**  
**Corrosive vapors and acid fumes can damage metal and plastic parts.**  
 Install motor in areas free of acid fumes and other deteriorating vapors.

**CAUTION**  
**Equipment Damage Hazard.**  
**Tightly securing actuator to damper housing can damage actuator.**  
 Mount actuator to allow it to float along its vertical axis.

### Preparation

- Before mounting the actuator onto the damper shaft, determine the:
- Damper/valve opening direction for correct spring return rotation. The actuator can be mounted to provide clockwise or counterclockwise spring return by flipping or turning the unit over.
  - Damper shaft size (see the Specifications section).

### Determine Appropriate Mounting Orientation

The actuators are designed to open a damper by driving the damper shaft in either a clockwise ↻ or counterclockwise ↺ direction (see Fig. 3).

- NOTES:
- Actuators are shipped in the fully closed (spring return) position.
  - The groove on the adapter points to a location on the label to indicate the hub rotary position.

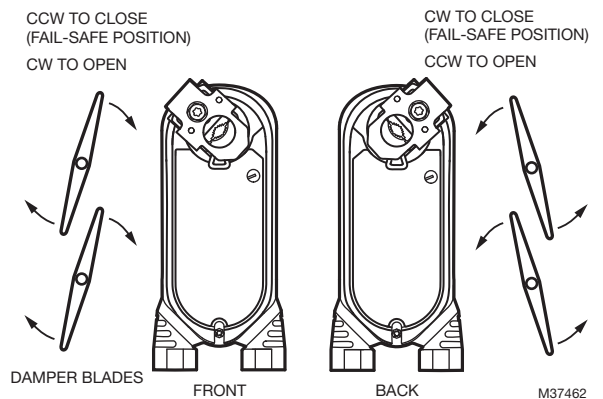

**Fig. 3. Spring Return DCA mounting orientation.**

### Measure Damper/Valve Shaft Length

If the shaft is less than 3.25 in. long for SCSA, the shaft coupling must be located between the damper/valve and actuator housing. If the shaft length is more than three inches, the shaft coupling may be located on either side of the actuator housing.

If the coupling must be moved from one side of the actuator to the other, reverse the spring return direction and flip the actuator. Follow these instructions (see Fig. 4):

1. Remove the retainer clip from the shaft coupling and set it aside for later use.
2. Remove shaft coupling from one side of the actuator.
3. Replace the shaft coupling on the opposite side of the actuator aligning it based on the stroke labeling.
4. Replace the retainer clip on the shaft coupling using the groove of the coupling.

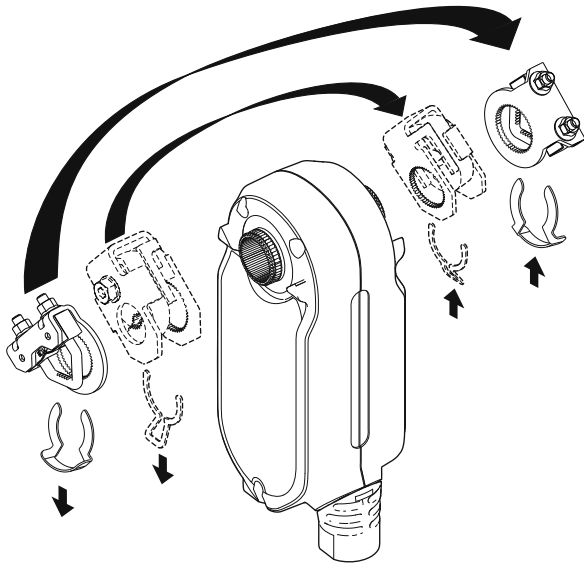
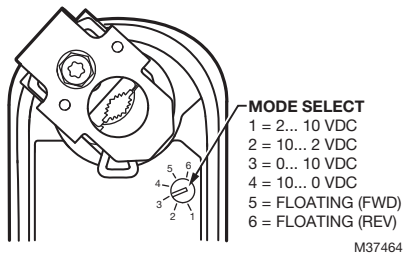

**Fig. 4. Mounting shaft coupling to actuator opposite side.**

### Selecting Actuator Control Signal (For MS7503 models only)

Selections are made using a dial that appears on both the front and back of the actuator (see Fig. 5).

To select the control signal simply turn the mode selection dial to the desired mode (as indicated on the device label) without exceeding range indicators.



**Fig. 5. Dials for control signal.**

### Non-Standard Stroke

#### Mechanical Stroke Limit Reduction

For applications requiring a span less than 95 degrees, a simple adjustment can be made. When the rotational mounting of the shaft coupling is changed, the actuator drives less than the full 95 degrees stroke.

The stroke is adjustable in 7.5 degree increments. Once adjusted, the actuator drives until the shaft coupling reaches the mechanical stop (part of the housing). The stop causes the motor to discontinue driving and the shaft coupling drives no farther. When the actuator returns, it stops at the fail-safe position. Mechanical limitation of minimum position is prohibited. Use electronic or SW limitation if needed.

To limit the stroke range, proceed as follows:

1. Remove the retainer clip from the shaft coupling and set it aside for later use.
2. Remove shaft coupling from the actuator.
3. Rotate the coupling to the desired position, aligning it based on the stroke labeling. See Fig. 6.

NOTE: The shaft coupling location determines the travel span.

EXAMPLE: Setting shaft coupling to an approximate fail-safe position of 30 degrees (as indicated on the housing) limits stroke to 60 degrees. (See Fig. 6)

4. Install the shaft coupling at this position.
5. Replace the retainer clip on the shaft coupling using the groove of the coupling.

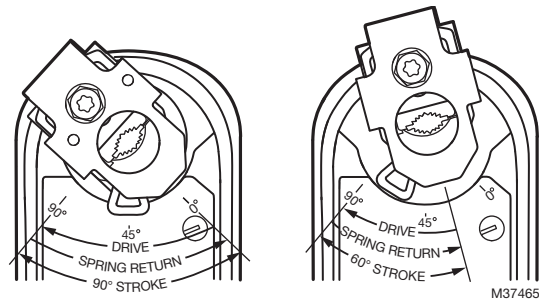

**Fig. 6. Stroke reduction.**

### Mounting



#### CAUTION

**Device Malfunction Hazard.**  
Improper shaft coupling tightening causes device malfunction.

Tighten shaft coupling with proper torque to prevent damper shaft slippage.



#### CAUTION

**Actuator Damage Hazard.**  
Using actuator as shaft bearing causes device damage.

Use actuator only to supply rotational torque. Avoid any side loads to actuator output coupling bearings.



## CAUTION

### Equipment Damage Hazard.

#### Can damage the motor beyond repair.

Never turn the motor shaft by hand or with a wrench.

Forcibly turning the motor shaft can damage the gear train.

To mount the actuator to an external drive shaft of a damper, proceed as follows:

1. Place actuator over damper shaft; and hold mounting bracket in place. See Fig. 9.
2. Mark screw holes on damper housing.
3. Remove actuator and mounting bracket.
4. Drill or center-punch holes for mounting screws (or use no.10 self-tapping sheet metal screws).
5. Turn damper blades to desired normal (closed) position.
6. Place actuator and mounting bracket back into position and secure bracket to damper box with sheet metal screws.
7. Using 10 mm wrench, tighten shaft coupling securely onto damper shaft using maximum 106 lb-in. (12 Nm) torque.

NOTE: See Fig. 7 for proper mounting to a square damper shaft.

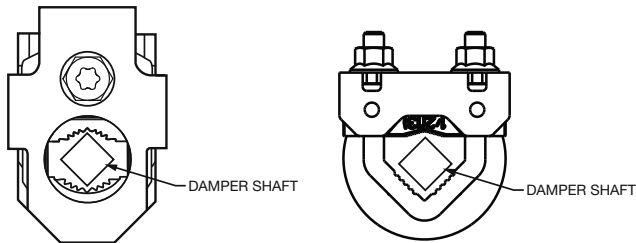

**Fig. 7. Proper mounting to square damper shaft.**

To achieve ingress protection rating IP54, the actuator needs to be mounted according to Fig. 8. IP54 applies for all mounting positions except with cable-up position (crossed out) Fig. 8.

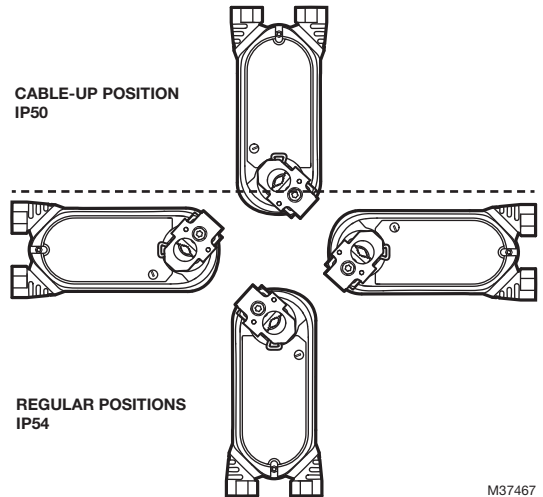

**Fig. 8. Mounting actuator for IP compliance.**

### Detail with U-Bolt

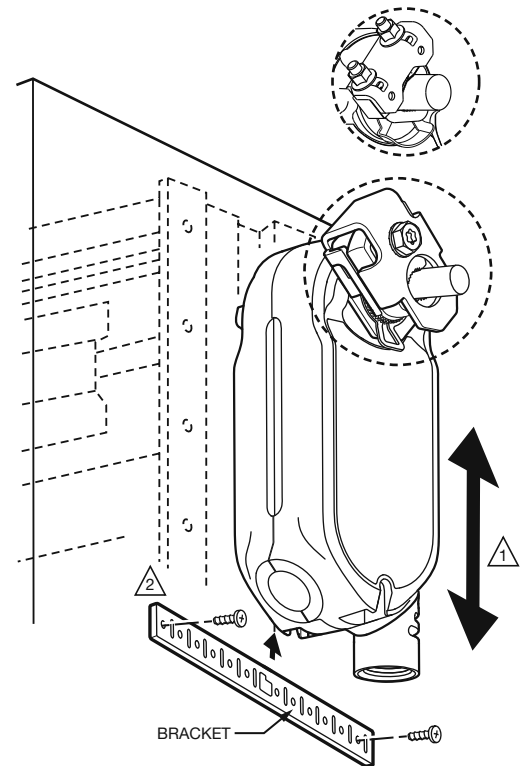

1 ENSURE THAT MOUNTING ASSEMBLY PREVENTS ACTUATOR ROTATION AND ALLOWS ACTUATOR TO FLOAT ALONG INDICATED AXIS. WHEN TOO TIGHT, THE RESULTING BINDING CAN DAMAGE THE ACTUATOR OR REDUCE TORQUE OUTPUT.

2 THE BRACKET CAN BE BENT TO ALLOW MOUNTING THE ACTUATOR PARALLEL TO THE MOUNTING SURFACE.

**Fig. 9. Mounting actuator to damper housing.**

# WIRING

**CAUTION**  
**Electrical Shock or Equipment Damage Hazard.**  
**Disconnect all power supplies before installation.**  
 Motors with auxiliary switches can have more than one disconnect.

**IMPORTANT**  
 All wiring must comply with local electrical codes, ordinances and regulations.

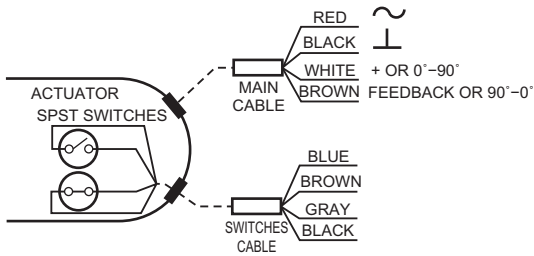

Fig. 10. Cable installation details.

## Switch operation

Gray/Black = Normally Open. Closed in range 80 degrees to Fully Open.

Blue/Brown = Normally Closed. Open in range 10 degrees to Fully Open.

Table 3. Wiring Details.

Wire		Floating	Modulating
RED	~	power	power
BLACK	⊥	common	common
WHITE <sup>2</sup>	0° - 90°		control signal
BROWN	→	90° - 0°	feedback <sup>1</sup>

<sup>1</sup> Not available on all modulating models, see Table 1.

<sup>2</sup> Brown for MS3103.

## Floating and Modulating Models

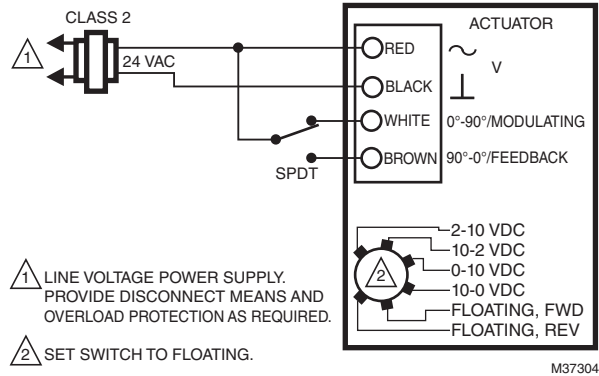

Fig. 11. Wiring for SPDT on/off control, MS75.

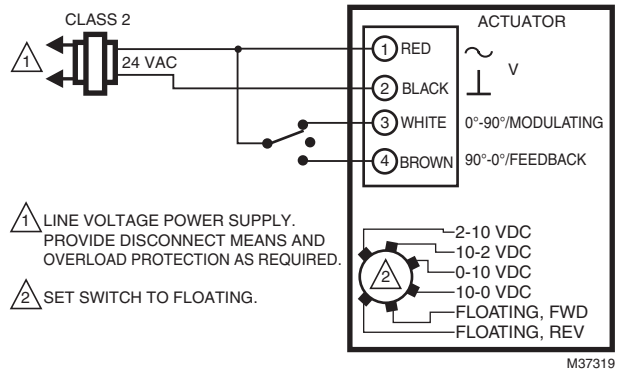

Fig. 12. Wiring for floating control, MS75.

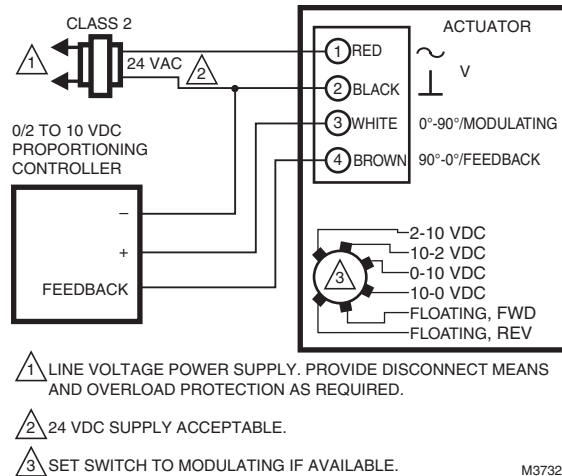

Fig. 13. Wiring for modulating (0/2-10 VDC) proportioning control, MS75 (shown) and MS71.

## OPERATION

The actuator is designed to be used in ventilating and air conditioning installations to operate valves, dampers, ventilation flaps and louvers. (For ratings, see the Specifications section.) If the power fails, the actuator will spring return to the fail safe position.

When using a proportional controller and actuator is set to (O)2 - 10 position, the actuator drives toward its fully open position when the input signal increases; the actuator drives toward the fully closed position when the input signal decreases. The actuator stops when the input signal reaches the desired proportional control point. This operates in reverse when set to a 10-2(O) position.

### IMPORTANT

*The actuator is designed to respond to DDC Controller instantaneous contact closures. Take care not to short cycle the actuator. Unstable damper control can cause premature actuator failure.*

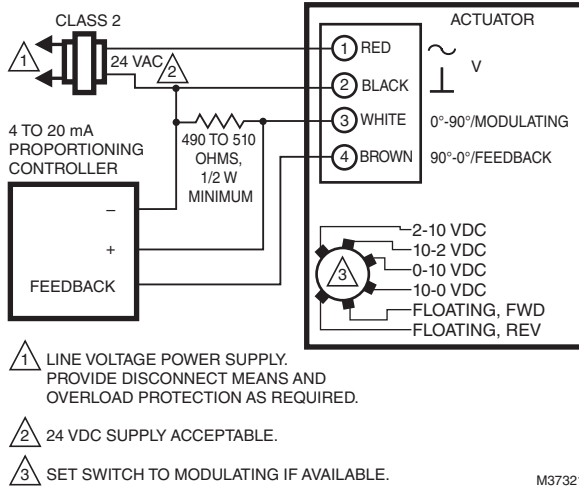

**Fig. 14. Wiring for 4-20 mA proportioning controllers, MS75 (shown) and MS71.**

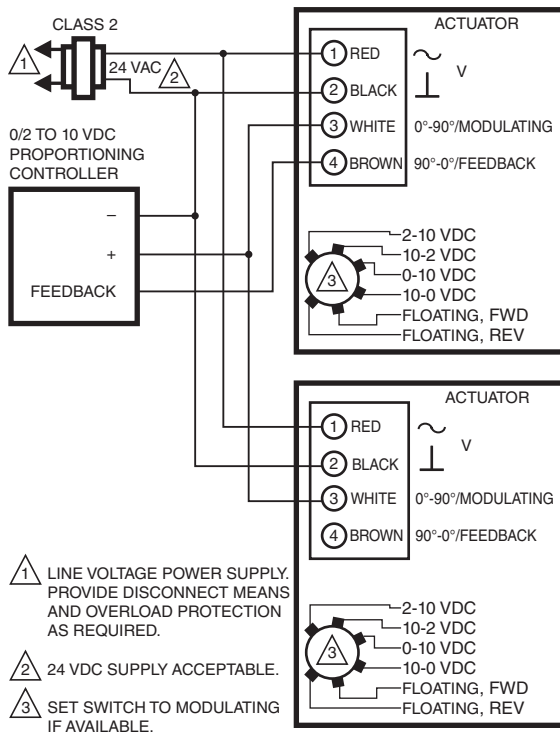

**Fig. 15. Wiring for modulating (0/2-10 VDC) proportioning control operating multiple actuators, MS75 (shown) and MS71.**

### Fast commissioning mode (modulating control mode)

When 24 VAC or 24 VDC signal is applied to the modulating input, the actuator will drive to the fully open position with higher speed corresponding to 30 sec timing. When the signal is disconnected, the actuator will drive to the fully closed position with normal operation timing.



### CAUTION

**Do not use fast test mode for permanent operation.**

Lifetime will be reduced if this mode is used permanently. This mode is intended to be used only for initial commissioning/testing of the system after installation. Power consumption is not specified in this mode.

### Auxiliary Switches

Some models include Auxiliary switches. For wiring details see Fig. 10.

### Actuator Override

To override the control signal (for freeze protection or similar applications):

1. Override to full open (fast commissioning, drive mode lower than 30 sec):
  - a. Disconnect the input signal (from terminal 3).
  - b. Apply 24 VAC to terminal 3.
  - c. See Fig. 16.

2. Return to full closed:
  - a. Disconnect the input signal (from terminal 3).
  - b. See Fig. 17.

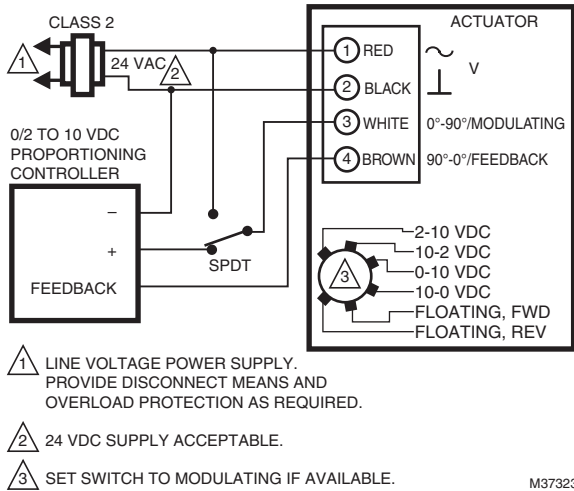

Fig. 16. Override to open position.

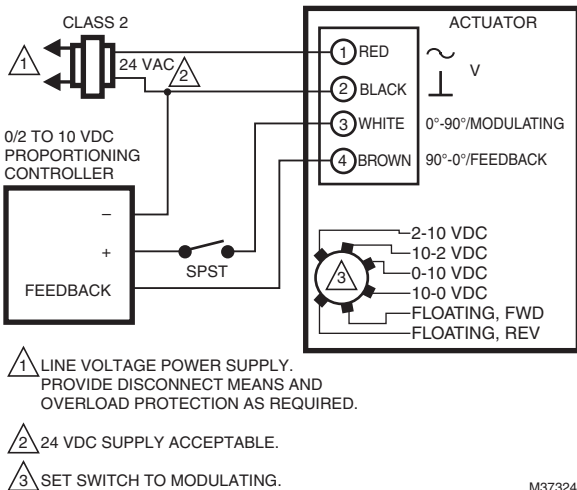

Fig. 17. Return to closed position.

## CHECKOUT

### Modulating/Floating Operation

1. Mount actuator for required application (either clockwise ↻ or counterclockwise ↻ rotation to open the damper).
2. Connect power to power and common wire. (See Fig. 10 and Table 3.)
3. Set "Mode Select" dial to desired control signal. (See Fig. 5.)

4. Apply control signal for actuator full open or full closed position. (See Fig. 10 and Table 3.)
  - a. (0)2-10 VDC: apply 10 VDC signal to control wire (WHITE).
  - b. 10-(0)2 VDC: apply (0)2 VDC signal to control wire (WHITE).
  - c. (0)4-20 mA: apply 20 mA signal to control wire (WHITE).
  - d. 20-(0)4mA: apply (0)4 mA signal to control wire (WHITE).
  - e. Floating: apply 24 VAC to appropriate 0°-90° (WHITE) or 90°-0° (BROWN) wire.
5. Actuator drives to full open or full closed position.
6. Apply control signal for actuator 0% position. (See Fig. 10 and Table 3.)
  - a. (0)2-10 VDC: apply (0)2 VDC signal to control wire (WHITE).
  - b. 10-(0)2 VDC: apply 10 VDC signal to control wire (WHITE).
  - c. (0)4-20 mA: apply (0)4 mA signal to control wire (WHITE).
  - d. 20-(0)4mA: apply 20 mA signal to control wire (WHITE).
  - e. Floating: apply 24 VAC to appropriate 0°-90° (WHITE) or 90°-0° (BROWN) wire.
7. Actuator drives to full open or full closed position.

### Spring Return Operation





1. Mount actuator for required application (either clockwise ↻ or counterclockwise ↻ rotation to open the damper or valve).
2. Connect power to power and common wire. (See Fig. 10 and Table 3.)
3. Set "Mode Select" dial to desired control signal. (See Fig. 5.)
4. Apply control signal for actuator 50% position.
  - a. VDC Input Signal: apply 5-6 VDC signal to control wire (WHITE). See Fig. 13.
  - b. mA Input Signal: apply 10-12 mA signal to control wire (WHITE). See Fig. 13.
  - c. Floating: apply 24 VAC to appropriate 0°-90° (3) or 90°-0° (4) wire until device reaches 50%.
5. Allow the actuator to drive to 50% position.
6. Disconnect power wire (RED).
7. Actuator spring returns to 0% position.
8. Re-connect power wire (RED), actuator drives back toward 50% position.

### Feedback Operation

1. Connect a multi-meter, set for VDC, to common (BLACK) and feedback (BROWN) wire.
2. Apply the same signal as in step 4 of Modulating Operation.
3. The multi-meter reading increases to match the input signal as actuator drives towards full open or full closed position.
4. Apply the same signal as in step 6 of Modulating Operation.
5. The multi-meter reading decreases to match the input signal as actuator drives towards 0% position.



## Direct Checkout

1. Mount actuator for required application (either clockwise  or counterclockwise  rotation to open the damper or valve).
2. Check damper position and make sure that 24 VDC/VAC is present at the appropriate connections. (See Fig. 10.)
3. Apply control signal to the appropriate connections to move the damper to the opposite position. The actuator should drive the damper or valve.
4. If actuator does not run, verify that the actuator is properly installed for either clockwise  or counterclockwise  rotation.
5. If actuator is correctly installed and still does not run, replace the actuator.

## NFC description

- Device complies with ISO/IEC 14443A.
- NFC can be utilized for communication between the actuator and NFC equipped device.
- The NFC access area location is shown in Fig. 18.
- If the NFC access point is facing the damper, limited access from the edge on the side of the power wires may be possible depending on installation and NFC device capabilities.

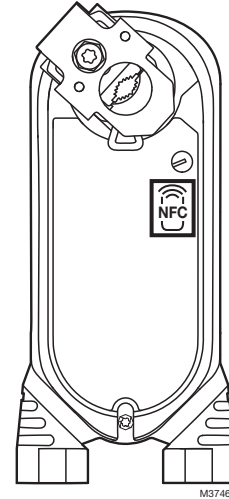

**Fig. 18. NFC access area location.**

## Security instructions

Physical security control, such as a locked cabinet, equipment room or any other placement of the device that restricts physical access to it, is recommended to prevent device tampering and unauthorized manipulation of the parameters accessible via NFC connection. Connection to the device via NFC is secured using a PIN. Each device is preset with a factory default PIN. The factory default PIN is 2586 and is the same for all devices of this product family. It is recommended that the default PIN is changed to a user unique PIN. The user unique PIN can be canceled using the factory default PIN at any time.

## CHINA HAZARDOUS SUBSTANCE TABLE

部件名称	有害物质 Hazardous Substances					
	铅 (Pb)	汞 (Hg)	镉 (Cd)	六价铬 (Cr6+)	多溴联苯 (PBB)	多溴二苯醚 (PBDE)
印刷电路板 PCB	X	O	O	O	O	O
齿轮 Gears	X	O	O	O	O	O
接线端子 Terminal block	X	O	O	O	O	O
电机 Electric motor	X	O	O	O	O	O
弹簧 Spring	X	O	O	O	O	O
本表格依据 SJ/T 11364 的规定编制。						
O: 表示该有害物质在该部件所有均质材料中的含量均在 GB/T 26572 规定的限量要求以下。						
X: 表示该有害物质至少在该部件的某一均质材料中的含量超出 GB/T 26572 规定的限量要求。						

" 未列入表内的其他部件，皆不含任何超出限量要求的限制使用物质。

All other components not listed in the table do not contain restricted substances above the threshold level.



By using this Honeywell literature, you agree that Honeywell will have no liability for any damages arising out of your use or modification to, the literature. You will defend and indemnify Honeywell, its affiliates and subsidiaries, from and against any liability, cost, or damages, including attorneys' fees, arising out of, or resulting from, any modification to the literature by you.

**Honeywell**

In the U.S.:

715 Peachtree Street NE

Atlanta, GA 30308

[customer.honeywell.com](http://customer.honeywell.com)

® U.S. Registered Trademark  
© 2019 Honeywell International Inc.  
31-00141M-03 M.S. Rev. 04-19  
Printed in United States

**Honeywell**