

Mounted Ball Bearings

Modular bearing assembly consisting of sealed and lubricated inch or metric ball bearing contained within a variety of housings types, locking mechanisms, mounting styles, and housing materials. Mounted ball bearings provide an anti-friction solution when supporting rotating shafts with radial loads.

Housing Styles

Pillow Block, Flanges, Take Up Assemblies

Locking Styles

Setscrew, Double Setscrew, Concentric And Eccentric

Bore Diameter Size Range

½" To 4 15/16" And 20 mm To 100 mm

Housing Materials

Cast & Ductile Iron, Stamped Steel



Mounted Ball Bearing Selection Guide

Brand	Image	Series	Housing Style	Duty	LOCK TYPE		
					Setscrew	Concentric	Double Setscrew
Sealmaster		NP	Two Bolt Pillow Block - High Base	Standard	NP	NP-T	NPD
		NPL	Two Bolt Pillow Block - Low Base	Standard	NPL	NPL-T	
		SP	Two Bolt Pillow Block - Heavy Duty	Standard	SP	SP-T	SPD
		MP	Two Bolt Pillow Block - High Base	Medium	MP	MP-T	MPD
		MFP	Four Bolt Pillow Block - High Base	Medium	MFP		MFPD
		MSPD	Two Bolt Pillow Block - Heavy Duty	Medium			MSPD
		MSFPD	Four Bolt Pillow Block - Heavy Duty	Medium			MSFPD
		SPM	Two Bolt Pillow Block - Heavy Duty	Medium	SPM		
		TB	Tapped Base Pillow Block	Standard	TB	TB-T	
		SF	Four Bolt Flange	Standard	SF	SF-T	
		MSF	Four Bolt Flange	Medium	MSF	MSF-T	
		SFT	Two Bolt Flange	Standard	SFT	SFT-T	
		MSFT	Two Bolt Flange	Medium	MSFT	MSFT-T	



Housing Material	Standard Seal	Seal Options	SIZE RANGE		Section Name	Pages
			Inch	Metric		
Cast Iron	Felt	Contact	1/2" - 2 15/16"	20mm - 75mm	Performance Mounted Ball Bearings	G-31 to G-33
			1/2" - 2 11/16"	20mm - 60mm		G-34 to G-35
			13/16" - 3 7/16"	36mm - 80mm		G-36 to G-38
			15/16" - 4"	25mm - 100mm		G-39 to G-41
			1 15/16" - 5"	50mm - 100mm		G-42 to G-43
			1 11/16" - 4 15/16"	N/A		G-44
			1 15/16" - 4 15/16"	N/A		G-45
			1 3/16" - 2 1/2"	N/A		G-46
			1/2" - 2"	20mm - 50mm		G-47 to G-48
			1/2" - 2 15/16"	20mm - 75mm		G-49 to G-50
			15/16" - 4 15/16"	25mm - 100mm		G-51 to G-52
			1/2" - 2 3/16"	20mm - 55mm		G-53 to G-54
			15/16" - 2"	25mm - 50mm		G-55 to G-56









Mounted Ball Bearing Selection Guide

Brand	Image	Series	Housing Style	Duty	LOCK TYPE		
					Setscrew	Concentric	Double Setscrew
Sealmaster		FB	Flange Bracket	Standard	FB	FB-T	
		SFC	Piloted Flange Cartridge	Standard	SFC	SFC-T	
		MFC	Piloted Flange Cartridge	Medium	MFC	MFC-T	MFCD
		SEHB	Hanger Bearing External Lube	Varies	SEHB	SEHB-T	SEHBD
		SCHB	Hanger Bearing Internal Lube	Varies	SCHB		
		SC	Cylindrical Cartridge	Standard	SC	SC-T	
		MSC	Cylindrical Cartridge	Medium	MSC	MSC-T	
		ST	Wide Slot Take Up	Standard	ST	ST-T	
		MST	Wide Slot Take Up	Medium	MST	MST-T	
		STH	Center Pull Take Up Frame	Standard	STH		
		MSTH	Center Pull Take Up Frame	Medium	MSTH		
		NPG	Top Mount Take Up Frame	Standard	NPG		



Housing Material	Standard Seal	Seal Options	SIZE RANGE		Section Name	Pages
			Inch	Metric		
Cast Iron	Felt	Contact	1/2" - 2"	20mm - 50mm	Performance Mounted Ball Bearings	G-57 to G-58
			1 1/8" - 3 3/16"	30mm - 80mm		G-59 to G-60
			15/16" - 4"	25mm - 100mm		G-61 to G-63
Ductile Iron			15/16" - 4"	25mm - 100mm		G-64 to G-66
			15/16" - 4"	25mm - 100mm		G-67
Cast Iron			1/2" - 2 15/16"	20mm - 75mm		G-68 to G-69
			15/16" - 4"	25mm - 100mm		G-70 to G-71
			1/2" - 3 7/16"	20mm - 80mm		G-72 to G-73
			15/16" - 4"	25mm - 100mm		G-74 to G-75
N/A			N/A	N/A		7/8" - 2 15/16"
	1 11/16" - 2 1/2"	N/A			G-79	
	7/8" - 2 3/16"	25mm - 55mm			G-80 to G-82	

Mounted Ball Bearing Selection Guide







Brand	Image	Series	Housing Style	Duty	LOCK TYPE		
					Setscrew	Concentric	Double Setscrew
Sealmaster		SPG	Top Mount Take Up Frame	Standard	SPG		
		TFT-T	Two Bolt Flange	Standard		TFT-T	
		SRF	Rubber Mounted Flange	Light	SRF		
		SRP	Rubber Mounted Pillow Block	Light	SRP		
		SRC	Rubber Mounted Cartridge	Light	SRC		
		RB	Rubber Mount Insert	Light	RB		
		AR-2	Expansion Insert	Standard	AR-2	AR-2-T	
		AR-3	Expansion Insert	Medium	AR-3	AR-3-T	
		2-	Insert	Standard	2-	2-T	2-D
		3-	Insert	Medium	3-	3-T	3-D
		ER	Cylindrical O.D. Insert	Standard	ER	ER-T	
		NPMH	Pillow Block	Standard	NPMH	NPMH-T	
		TBMH	Tapped Base Pillow Block	Standard	TBMH	TBMH-T	



			SIZE RANGE						
Housing Material	Standard Seal	Seal Options	Inch	Metric	Section Name	Pages			
N/A	N/A	N/A	2 1/4" - 2 15/16"	60mm - 75mm	Performance Mounted Ball Bearings	G-82			
Ductile Iron	Felt	Contact	15/16" - 1 7/16"	N/A		G-83			
Stamped Steel			1/2" - 1 1/4"	N/A		G-84			
			1/2" - 1 1/4"	N/A		G-85			
Rubber			1/2" - 1 1/4"	N/A		G-86			
N/A			1/2" - 1 1/4"	N/A		G-87			
Brass			1/2"-3 1/2"	20mm - 90mm		G-88 to G-89			
			15/16" - 4"	25mm - 100mm		G-90 to G-91			
N/A			1/2" - 3 1/2"	20mm - 90mm		G-92 to G-94			
			15/16" - 4 15/16"	25mm - 100mm		G-95 to G-97			
			1/2" - 4"	20mm - 80mm		Performance Cylindrical O.D. Bearings (ER) G-107 to G-108			
Cast Iron			Contact Seal + Flinger	N/A		1" - 2 3/16"	N/A	Material Handling Bearings	G-113 to G-114
						1" - 1 15/16"	N/A		G-115 to G-116



Mounted Ball Bearing Selection Guide

Brand	Image	Series	Housing Style	Duty	LOCK TYPE		
					Setscrew	Concentric	Double Setscrew
Sealmaster		SFMH	Four Bolt Flange	Standard	SFMH	SFMH-T	
		SFTMH	Two Bolt Flange	Standard	SFTMH	SFTMH-T	
		FBMH	Flange Bracket	Standard	FBMH	FBMH-T	
		STMH	Wide Slot Take Up	Standard	STMH	STMH-T	
		MH	Insert	Standard	MH	MH-T	
		PVR-x3xx	Pillow Block	Varies			
		PVR-x4xx	Tapped Base Pillow Block	Varies			
		PVR-x5xx	Four Bolt Flange	Varies			
		PVR-x6xx	Two Bolt Flange	Varies			
		PVR-x1xx	Piloted Flange Cartridge	Varies			
		PVR-x2xx	Hanger Bearing	Varies			
		PVR-x7xx	Cylindrical Cartridge	Varies			



			SIZE RANGE			
Housing Material	Standard Seal	Seal Options	Inch	Metric	Section Name	Pages
Cast Iron	Contact + Flinger		1" - 2 7/16"	N/A	Material Handling Bearings	G-117 to G-118
			1" - 2 3/16"	N/A		G-119 to G-120
			1" - 1 15/16"	N/A		G-121 to G-122
			1" - 2 3/16"	N/A		G-123 to G-124
			N/A	N/A		G-125 to G-126
Varies	Varies	N/A	1 1/8" - 1 3/4"	N/A	Paver Bearings	G-130
			1" - 2"	N/A		G-131
			1 1/2" 2 11/16"	N/A		G-132
			1 7/16" - 2"	N/A		G-133
			1 15/16" - 2 3/16"	N/A		G-134
			2" - 2 11/16"	N/A		G-135
			1 3/4"	N/A		G-136







Mounted Ball Bearing Selection Guide

Brand	Image	Series	Housing Style	Duty	LOCK TYPE		
					Setscrew	Concentric	Eccentric
Browning		VP 100	Two Bolt Pillow Block - High Base	Intermediate	VPS 100		VPE 100
		VP 200	Two Bolt Pillow Block - High Base	Standard	VPS 200	VPB 200	VPE 200
		VP 300	Two Bolt Pillow Block - High Base	Medium	VPS 300	VPB 300	
		VPL 100	Two Bolt Pillow Block - Low Base	Intermediate	VPLS 100		VPLE 100
		VPL 200	Two Bolt Pillow Block - Low Base	Standard	VPLS 200	VPLB 200	VPLE 200
		VPD 200	Two Bolt Pillow Block - Alternate Base	Standard	VPDS 200		
		VTB 100	Tapped Base Pillow Block	Intermediate			VTBE 100
		VTB 200	Tapped Base Pillow Block	Standard	VTBS 200	VTBB 200	
		VF4 100	Four Bolt Flange	Intermediate	VF4S 100		VF4E 100
		VF4 200	Four Bolt Flange	Standard	VF4S 200	VF4B 200	VF4E 200
		VF4 300	Four Bolt Flange	Medium	VF4S 300	VF4B 300	
		VF2 100	Two Bolt Flange	Intermediate	VF2S 100		VF2E 100
		VF2 200	Two Bolt Flange	Standard	VF2S 200	VF2B 200	VF2E 200



			SIZE RANGE			
Housing Material	Standard Seal	Seal Options	Inch	Metric	Section Name	Pages
Cast Iron	Contact	N/A	1/2" - 2 3/16"	N/A	Mounted Ball Bearings	G-145 to G-146
	Contact + Flinger		1/2" - 2 15/16"	20 mm - 60 mm		G-147 to G-150
			1" - 2 3/16"	N/A		G-151 to G-152
	Contact		1/2" - 2 3/16"	N/A		G-153 to G-154
	Contact + Flinger		1/2" - 2 7/16"	N/A		G-155 to G-157
			1 3/16" - 1 1/2"	N/A		G-158
	Contact		3/4" - 2"	N/A		G-159
	Contact + Flinger		1/2" - 2"	20mm - 50mm		G-160 to G-162
	Contact		1/2" - 2 3/16"	N/A		G-163 to G-164
	Contact + Flinger		1/2" - 2 7/16"	20mm - 60mm		G-165 to G-168
			1" - 2 3/16"	N/A		G-169 to G-170
			Contact	1/2" - 2 3/16"		N/A
	Contact + Flinger		1/2" - 2 7/16"	20mm - 60mm		G-173 to G-176









Mounted Ball Bearing Selection Guide

Brand	Image	Series	Housing Style	Duty	LOCK TYPE		
					Setscrew	Concentric	Eccentric
Browning		VF2 300	Two Bolt Flange	Medium	VF2S 300	VF2B 300	
		VFB 200	Flange Bracket	Standard	VFBS 200	VFBB 200	
		VFC 200	Piloted Flange Cartridge	Standard	VFCS 200	VFCB 200	
		VFC 300	Piloted Flange Cartridge	Medium	VFCS 300	VFCB 300	
		VTW 100	Wide Slot Take Up	Intermediate	VTWS 100		VTWE 100
		VTW 200	Wide Slot Take Up	Standard	VTWS 200		VTWE 200
		VTW 300	Wide Slot Take Up	Medium	VTWS 300		
		SF	Center Pull Take Up Frame	Standard	xFxx		
		TF	Top Mount Take Up Frame	Standard	xFxx		
		VP 100M	Pillow Block	Intermediate	VPS100-M		
		VF2 100M	Two Bolt Flange	Intermediate	VF2S100-M		
		VF3 100M	Three Bolt Flange	Intermediate	VF3S100-M		
		SSP 100	Pillow Block	Light	SSPS 100		



			SIZE RANGE			
Housing Material	Standard Seal	Seal Options	Inch	Metric	Section Name	Pages
Cast Iron	Contact + Flinger	N/A	1" - 2"	N/A	Mounted Ball Bearings	G-177 to G-178
			3/4" - 2"			G-179 to G-180
			1 1/8" - 2 7/16"			G-181 to G-182
			1" - 2 1/4"			G-183 to G-184
	Contact		3/4" - 2 3/16"			G-185 to G-186
	Contact + Flinger		1/2" - 2 7/16"			G-187 to G-188
N/A	N/A		1" - 2 1/4"			G-189
			1/2" - 2 7/16"			G-190
Ductile Iron	Contact		3/4" - 2 7/16"			G-191
			1/2" - 1 7/16"			G-192
			1/2" - 1 7/16"			G-193
1/2" - 1 7/16"			G-194			
Stamped Steel		7/8" - 1 1/4"	G-195			

Mounted Ball Bearing Selection Guide

Brand	Image	Series	Housing Style	Duty	LOCK TYPE		
					Setscrew	Concentric	Eccentric
Browning		SSRP 100	Pillow Block	Light	SSRPS 100		
		SSF4 100	Four Bolt Flange	Light	SSF4S 100		
		SSF3 100	Three Bolt Flange	Light	SSF3S 100		
		SSF3T 100	Three Bolt Flange	Light	SSF3TS 100		
		SSF2 100	Two Bolt Flange	Light	SSF2S 100		
		RUBR 100	Rubber Grommet	Light	RUBRS 100	RUBRB 100	RUBRE 100
		SL 100	Cylindrical O.D. Insert	Light	SLS 100		
		L 100	Insert	Light	LS 100		
		LR 100	Insert	Light	LRS 100		
		V 100	Insert	Intermediate	VS 100		VE 100
		V 200	Insert	Standard	VS 200	VB 200	VE 200
		V 300	Insert	Medium	VS 300	VB 300	
		VER 200	Cylindrical O.D. Insert	Standard	VER 200		



			SIZE RANGE						
Housing Material	Standard Seal	Seal Options	Inch	Metric	Section Name	Pages			
Stamped Steel with Rubber Grommet	Contact	N/A	3/4" - 1"	N/A	Mounted Ball Bearings	G-196			
Stamped Steel			1 1/2" - 1 15/16"			G-197			
			3/4" - 1 7/16"			G-198			
			3/4" - 1 1/4"			G-199			
			1/2" - 1 1/4"			G-200			
			1/2" - 1"			G-201 to G-202			
Rubber			N/A			1/2" - 1 1/2"	N/A	Mounted Ball Bearings	G-203
N/A						1/2" - 1 15/16"			G-204
						3/4" - 1 1/4"			G-205
						1/2" - 2 3/16"			G-206 to G-207
	1/2" - 2 7/16"	20mm - 60mm		G-208 to G-211					
	1" - 2 3/16"	N/A		G-212 to G-213					
	1/2" - 2 7/16"			Cylindrical O.D. Insert Bearings	G-218				
		Contact + Flinger							

Sealmaster Gold Mounted Ball Bearings

Sealmaster Gold mounted ball bearings feature a wide outer race insert bearing with land riding metallic retainer. The black oxide treated bearing steel insert features an exclusive lock pin and dimple system providing a direct path for lubrication into the bearing, and prevents outer ring rotation within the housing. Shaft lock is achieved by either setscrew or Skwezloc® concentric locking collar. The felt seal with flinger provide a good balance between contaminant entry, GoldPlex® HP grease loss and friction. Depending on your preference, these bearings are available in both inch and metric shaft sizes with a wide variety of cast iron, stamped steel or rubber mount housings, sealing, and lubrication options or industry specific solutions as illustrated on the pages to follow.

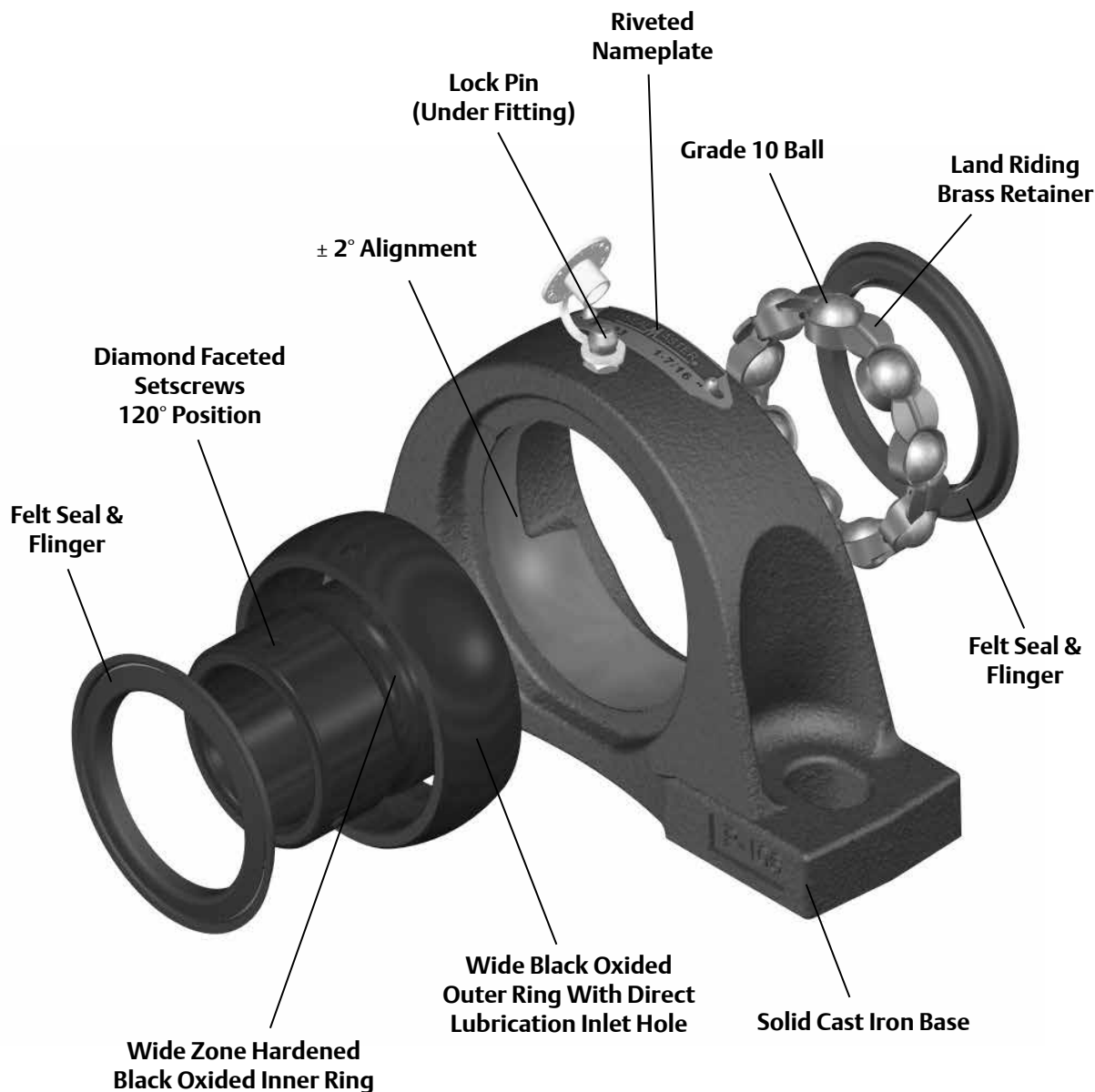



Sealmaster Gold Mounted Ball Nomenclature

Housing Units

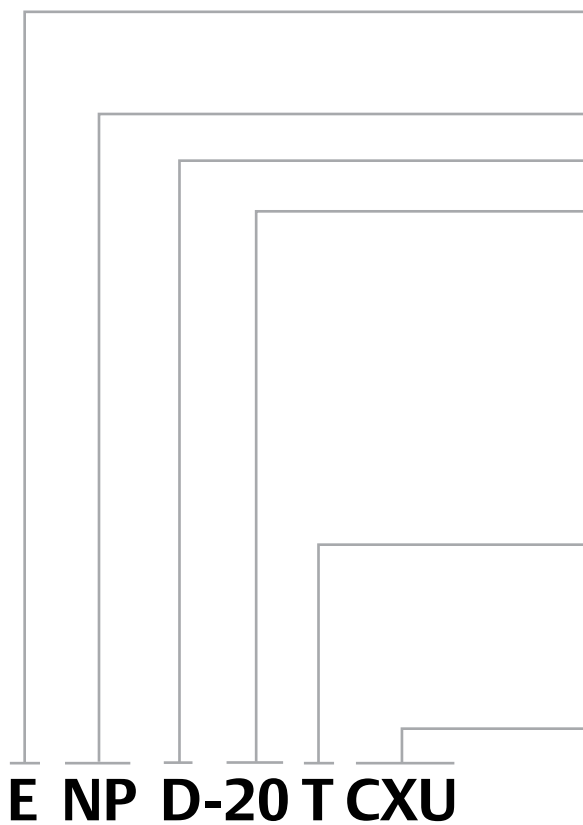

Prefix

E - Expansion Unit

Housing* (see table below)

D - Double Setscrew Locking

Bore Size

Inch - ##/16 (ex. 20/16 = 1 1/4")

R for 1 1/4" and 2" Reduced Only

Metric - Standard Duty - 2##, ## x 5 mm
(ex. 05 = 25 mm)

Medium Duty - 3##, ## x 5 mm
(ex. 07 = 35 mm)

Standard Option

T - Skwezloc® Locking Collar

M - Metric Hardware (Metric-SKWEZ™)

C - Contact Seal

Common Options* (see table below)

*Housing	Housing Style	Bearing Duty
FB	Flange Bracket	Standard
MFC	Piloted Flange Cartridge	Medium
MFP	Four Bolt Pillow Block - High Base	Medium
MP	Pillow Block - High Base	Medium
MSC	Cylindrical Cartridge	Medium
MSF	Four Bolt Flange	Medium
MSFPD	Four Bolt Pillow Block - High Base	Medium
MSFT	Two Bolt Flange	Medium
MSPD	Four Bolt Pillow Block - High Base	Medium
MST	Wide Slot Take Up	Medium
NP	Pillow Block - High Base	Standard
NPL	Pillow Block - Low Base	Standard
RB	Rubber Mount Insert Only	Standard
SC	Cylindrical Cartridge	Standard
SF	Four Bolt Flange	Standard
SFC	Piloted Flange Cartridge	Standard
SFT	Rubber Mounted Flange	Standard
SP	Pillow Block - Heavy Duty	Standard
SPM	Pillow Block - High Base	Medium
SRC	Rubber Mounted Cartridge	Standard
SRF	Rubber Mounted Flange	Standard
SRP	Rubber Mounted Pillow Block	Standard
ST	Wide Slot Take Up	Standard
TB	Tapped Base Pillow Block	Standard
TFT	Two Bolt Flange	Standard

***Common Options**

2C	Double Lip Contact Seal - replaced by DRT in most Sizes
3C	Trip Lip Contact Seal - replaced by DRT in most sizes
AS	Backed Off Felt Seal
BF	Spring Seal - Spring Out
CXU	Air Handling
DRT	High Contamination
H	High Performance Seal
HI	High Temperature Krytox*** Grease
HS	High Speed
HT	High Temperature
HTA	High Temperature Air Handling
HTC	High Temperature Contact Seal
LO	Low Drag
RM	Reduced Maintenance
SF	Double Lip Contact Seal
U	Spring Seal - Spring In
VA	FKM Spring Seal - Spring In
VS	FKM Spring Seal - Spring Out
X	Labyrinth Seal
XLO	Extra Low Drag

**Not all configurations available in all sizes. Prior to selection consult Bearing Application Engineer for proper option selection for your application and consult engineering sections for speed limits.

***KRYTOX is a registered trademark of E.I. du Pont de Nemours and Company. This trade name, trademark and/or registered trademark is property of their respective owner and is not owned or controlled by Power Transmission Solutions.

Sealmaster Gold Mounted Ball Nomenclature Inserts

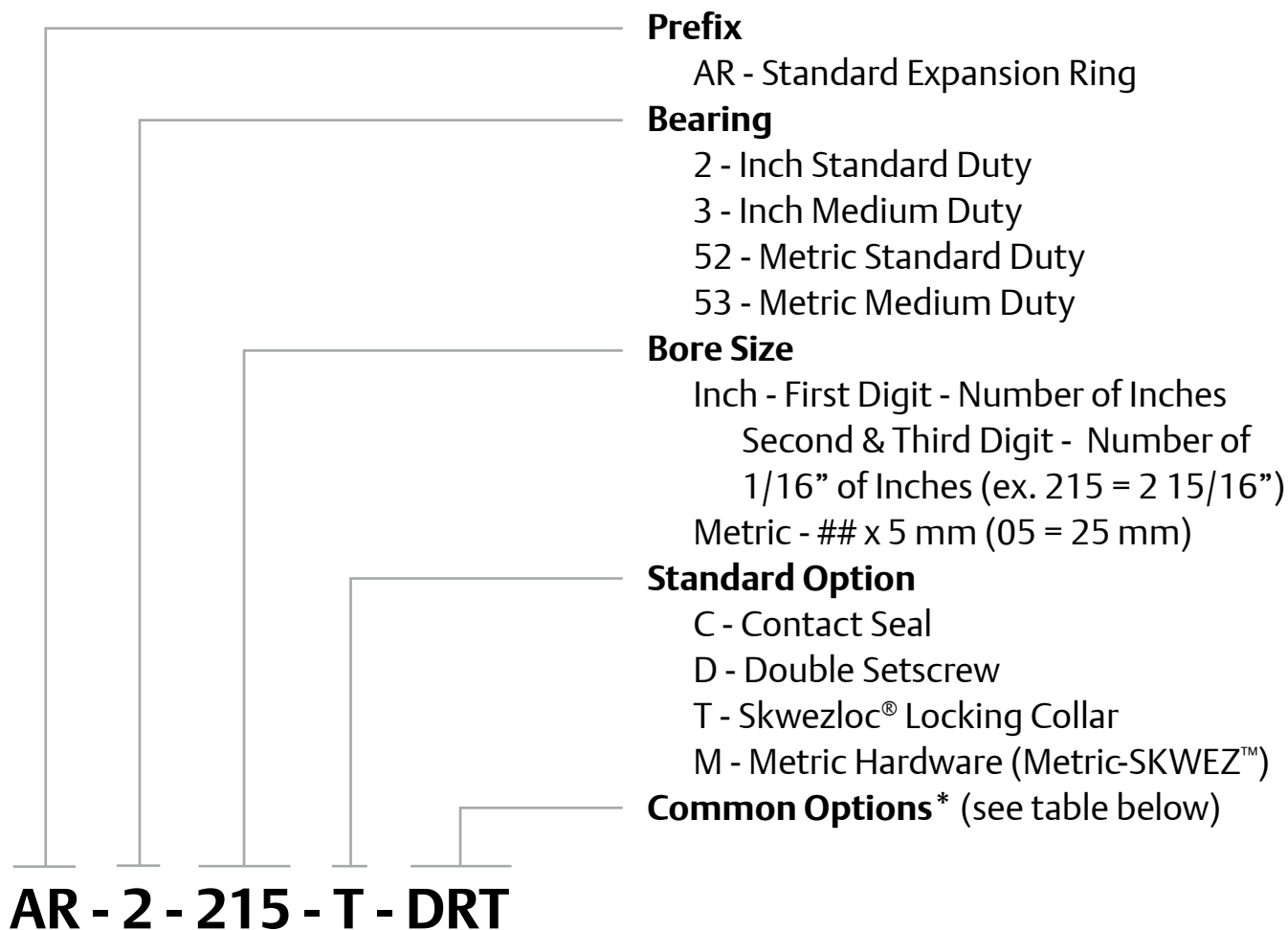

* Common Options

2C	Double Lip Contact Seal - replaced by DRT in most Sizes	LO	Low Drag
3C	Trip Lip Contact Seal - replaced by DRT in most sizes	M	Metric Hardware (Metric-SKWEZ only)
AS	Backed Off Felt Seal	RM	Reduced Maintenance
BF	Spring Seal - Spring Out	SF	High Temperature Double Lip Contact Seal
DRT	High Contamination	U	Spring Seal - Spring In
H	High Performance Seal	VA	FKM Spring Seal - Spring In
HI	High Temperature Krytox** Grease	VS	FKM Spring Seal - Spring Out
HS	High Speed	X	Labyrinth Seal
HT	High Temperature	XLO	Extra Low Drag
HTC	High Temperature Contact Seal		

*Note: Configurations are not available in all sizes or housing styles. Consult the product tables, option sections and engineering sections for more detail or consult a Bearing Application Engineer.

**KRYTOX is a registered trademark of E.I. du Pont de Nemours and Company. This trade name, trademark and/or registered trademark is property of their respective owner and is not owned or controlled by Power Transmission Solutions.

Sealmaster Gold Mounted Ball Nomenclature Specials

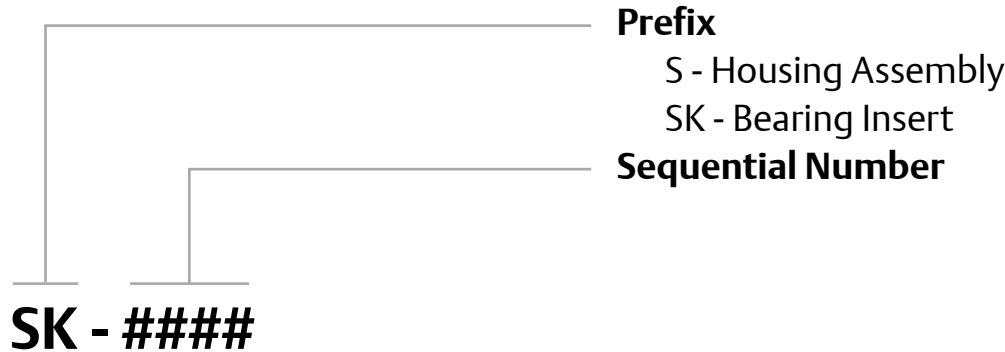

Take up Frames

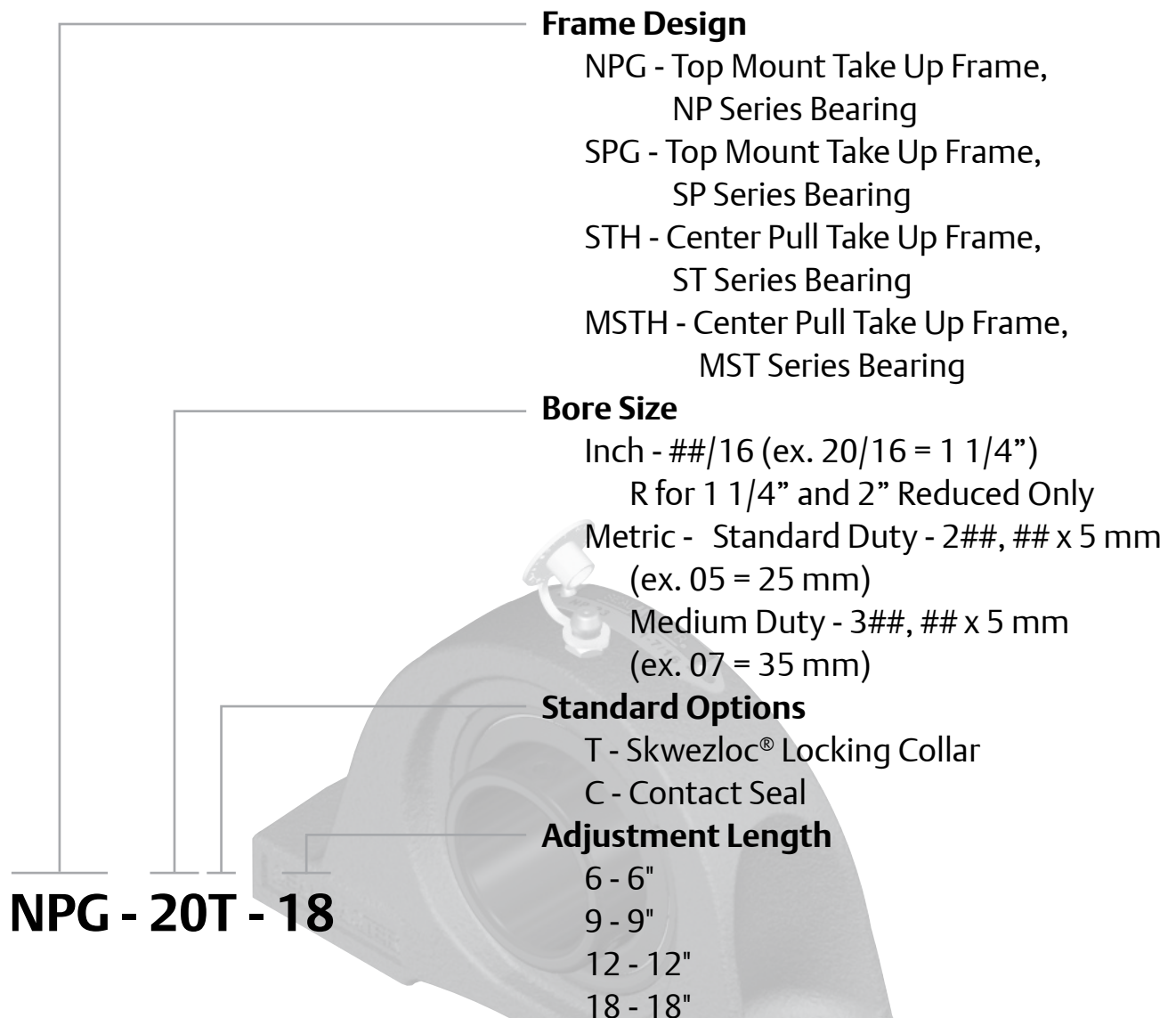

Features and Benefits



Wide Outer Ring

Sealmaster has the industry's widest outer ring. The black oxidized outer ring is 20 to 30% wider than industry standard outer rings. This feature results in increased grease capacity, and room for improved sealing options. A wider outer ring has increased surface area contact with the housing to better absorb shock load.

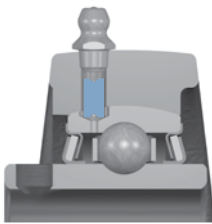

Lock Pin and Dimple

The Sealmaster exclusive locking pin and dimple system provides a direct lubricant path into the bearing cavity & ball path instead of around a lubrication groove. The pin also prevents outer ring rotation (sometimes referred to as "creep"), and allows $\pm 2^\circ$ static misalignment of the bearing insert.



Multiple Sealing Options Felt Seal with Flinger

The standard felt seal provides a tight labyrinth seal which retains lubrication and acts as a filter to exclude contamination. The external stamping is a flinger which shields the felt from large contaminants and directs them away from the sealing surface. The design operates with less drag and less heat generation than rubber contact seals.



Single Lip Contact Seal

Single Lip Contact Seal consists of a nitrile rubber washer in metal shroud to shield the lip from large contaminants. The seal is designed to balance drag and protection in wet and dry environments. This can be specified by adding the suffix C to the part number.

Additional Sealing Options can be found in the Custom Select section on pages G-24 to G-27.



Multiple Locking Methods Setscrew Locking

120° spaced, balanced three point contact minimizes inner ring distortion vibration, reduces noise, and improves reliability. Precision manufactured diamond faceted setscrews contribute to improved clamping and resistance to back out.

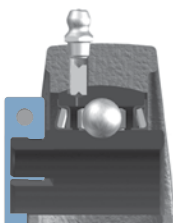

Skwezloc® Concentric Locking Collar

SKWEZLOC is a concentric locking collar clamp design that results in near-perfect concentricity of the shaft to bearing bore and maintains near perfect ball path roundness, while reducing fretting corrosion. This design eliminates the shaft damage of setscrew locking, and minimizes bearing induced vibration for smoother quieter operation. The collar has a TORX head cap screw that outlasts stripping 12 times longer than hex head cap screws.



Features and Benefits continued



Zone Hardened Inner Race

Sealmaster incorporates a unique heat treat process that hardens the inner race only where it is needed...under the ball path. The black oxidized zone hardened inner race results in improved lock reliability as a result of less distortion at the setscrew location and improved thread conformity resulting in improved clamping and resistance to setscrew back-out



Land Riding Retainer

The Sealmaster unique land riding metal retainer design provides superior pocket clearance that allows for 360° grease circulation around the rolling elements resulting in better retained and utilized lubrication. The land riding design of the retainer minimizes wear on both Ball and retainer, while maximizing stability, which is especially important in applications involving vibration, shock loading or high operating speeds.



Solid Base

Solid bases are standard on Sealmaster Gold ball bearing pillow blocks. The solid base provides improved stability, resistance to shock and vibration and prevents frame buckling under base compared to semi-solid and hollow mounting bases.



Housing Fit

All bearings are assembled with a controlled housing fit between the bearing outer ring and housing bore. This fit allows the bearing to properly self-align in common industrial applications. Special fits are available based on your specific application need.



Nameplate

Metal nameplate riveted to the housing allows for easy identification even after years of operation.



Options

Sealmaster Gold Mounted Ball Bearing Options

Bearings are typically selected using L10 fatigue life calculations based on ideal operating conditions. However, most bearing problems are not fatigue related, but occur due to contamination, lubrication starvation, or other environmental issues. As a result, our engineers have developed custom solutions to meet the varying severity, operating parameters and maintenance regularity, such as Reduced Maintenance and Custom Select.

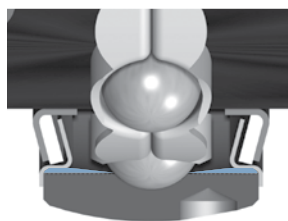

Reduced Maintenance “RM”

Sealmaster Reduced Maintenance bearings are the result of a patented Tapered Lands bearing race profile which means that critical lubricant is circulated more efficiently, while requiring no regular service intervals. The bearing are supplied from the factory with a plug instead of a lubrication fitting.

The outer land surface in a conventional bearing is parallel to the axis of the inner ring. The Tapered Lands surface is tapered in a radial direction toward the bearing race. This subtle yet crucial design change allows lubricant to more easily flow back to the raceway. With improved bearing lubricant circulation comes significantly longer bearing service life. This improved circulation and service life comes without any reductions in bearing radial or thrust capacities.

* For bearings that are maintained and relubricated on a regular basis, there is no significant difference in expected service life.



Custom Select

Sealmaster Custom Select options are available in popular shaft sizes from 1/2" to 2 7/16" in common housing configurations.

High Temperature

Suffix	Description	Temperature	Environment	Speed Limits
HT*	Standard High Temp	200°F to 400°F	Dry/Dusty	pages G-235 to G-240
HI*	High Performance High Temp			
HTA*	High Temp Air Handling		Wet/Moisture	
HTC*	High Temp Contact Seal			

*For expansion units add an E prefix (example: ENP-23 HTA). Information on expansion units can be found on page G-29.



High Temperature "HT"

High temperature bearing with increased radial internal clearance to accommodate thermal expansion of components and Nomex* seal and high temperature synthetic grease.

High Performance High Temperature "HI"

High temperature bearing with increased radial internal clearance to accommodate thermal expansion of components and Nomex** seal and Krytox* 226 grease. Available in expansion version in some sizes with half-dog and wire, suffix "HIY", see page G-104 for more information.



High Temperature Air Handling "HTA"

Utilizes the same features as our high temperature "HT" option with the additional features that are important in Air Handling equipment:

- Controlled air handling housing fit that allows the bearing to properly self-align when mounted on light weight frames
- Two stage noise testing verification procedure for quiet operation
- For standard operating temperatures, consider the Air Handling "CXU" option shown on following pages

High Temperature Contact Seal "HTC"

High temperature bearing with increased radial internal clearance to accommodate thermal expansion of components, single lip silicone fiberglass or FKM spring seal and high temperature synthetic grease.

**NOMEX and Krytox are registered trademarks of E.I. du Pont de Nemours and Company. This trade name, trademark and/or registered trademark is property of their respective owner and is not owned or controlled by Power Transmission Solutions.
 Note: See page G-30 for additional information on grease lubricants listed above.



Custom Select continued

High Contamination

Suffix	Description	Temperature	Environment	Speed Limits
DRT	Highly Contaminated	-40°F to 200°F	Highly Contaminated	pages G-235 to G-240



2C Seal



3C Seal

High Contamination “DRT”

Heavy Duty Multi-Lip contact seal (depending on size and series, either supplied with “2C” double lip or “3C” triple lip seal), 100% Grease Fill with Sealmaster GoldPlex HP Grease.

High Speed

Suffix	Description	Temperature	Environment	Speed Limits
HS	High Speed	-40°F to 200°F	Dry/Dusty	pages G-235 to G-240

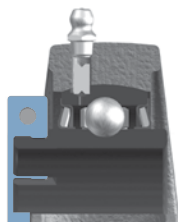

High Speed “HS”

- Available in SKWEZLOC locking collar only
- Backed off, felt seal reduces contact area between the felt sealing material and the internal metal flinger
- Controlled air handling housing fit that allows the bearing to properly self-align when mounted on lightweight frames
- Increased radial internal clearance to accommodate radial thermal expansion of components



Custom Select continued

Air Handling

Suffix	Description	Temperature	Environment	Speed Limits
CXU	Air Handling	-40°F to 200°F	Dry/Dusty	pages G-235 to G-240
HTA*	High Temp Air Handling	200°F to 400°F		

*For expansion units add an E prefix to unit assembly (example: EMP-23 HTA)



Air Handling “CXU”

Utilizes many of the same features as standard Sealmaster Gold Mounted Ball Bearings but designed and manufactured for Air Handling equipment.

- Controlled air handling housing fit that allows the bearing to properly self-align when mounted on lightweight frames
- Available with the standard Sealmaster felt seal for decreased energy consumption
- Two stage noise testing verification procedure for quiet operation

High Temperature Air Handling “HTA”

Features listed on page G-24



Custom Select continued

Low Drag

Suffix	Description	Temperature	Environment	Speed Limits
LO	Low Drag	-20°F to 180°F	Dry/Dusty	pages G-235 to G-240
XLO	Extra Low Drag	-20°F to 100°F		

Low Drag “LO”

- Felt seal cut down to reduce drag
- Provides excellent barrier that works to retain grease and acts as a filter to reduce the ingress of debris contaminants
- Features a channeling grease that reduces drag while lubricating the bearing
- A reduced housing fit to allow for the bearing to properly self-align on light weight frames

X-Tra Low Drag “XLO”

- Felt seal cut down and oil soaked for extra low drag
- Oil lubricated and supplied with an adapter and plug for easy field relubrication
- A reduced housing fit to allow for the bearing to properly self-align on light weight frames

Bearing Rotational Torque - Comparison Chart

	Company	Suffix Option	Seal Type	Lubrication
LO Drag Bearing Options	AMI®	FS	Non-Contact	Oil
	Sealmaster	XLO	Low Drag Felt	Oil
	MB®	HFF	Steel Labyrinth	Oil
	Peer®	ZSFF	Steel Labyrinth	Oil
	Sealmaster	LO	Low Drag Felt	Grease
	MB	MHFF	Steel Labyrinth	Grease
	FYH®	DSK3	Non-Contact	Oil
	Peer	ZMKFF	Steel Labyrinth	Grease
Standard Bearing Drag (Reference)	Sealmaster	-	Felt	Grease
	Sealmaster	C	Contact	Grease

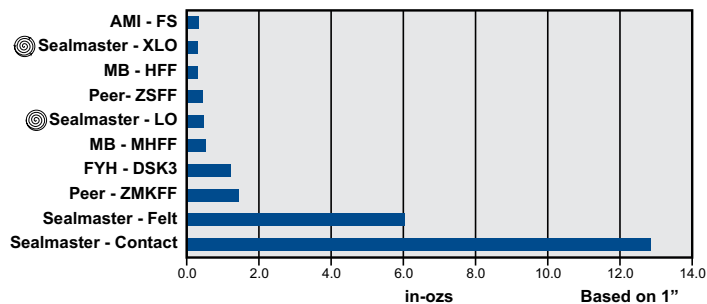

* The following trade names, trademarks and/or registered trademarks that follow are used in this material by Emerson for comparison purposes only, are NOT owned or controlled by Emerson and are believed to be owned by the following parties: Dodge: Baldor Electric Company; AMI: Asahi Tec Corp. of Japan; MB: Rexnord Industries, Inc.; Peer: Peer Bearing Company; FYH: Nippon Pillow Block Co., Ltd. Fafnir: Timken US Corporation. Emerson cannot and does not represent or warrant the accuracy of this information.



Custom Select continued

Optional Fittings

Suffix	Description
CSK	90° Grease Fitting
CSJ	45° Grease Fitting
CTJ	Adapter and Plug
CTY	Plug
W	Adapter and Grease Fitting



CSK – 90° Grease Fitting



CSJ – 45° Grease Fitting



CTJ – Adaptor and Plastic Plug



CTY - Plug



W – Adaptor and Grease Fitting

Note:

- Fittings are designed to properly position the lock pin anti-rotation device. Other fittings not designed for Sealmaster brand bearings may not provide this function causing reduced bearing life.
- Fittings are factory adjusted to properly position the lock pin anti-rotation device. Improper field adjustment of the fitting may cause reduced bearing life. Consult Bearing Technical Services for proper adjustment techniques or review installation instructions.
- For specific hole sizes per housing assembly refer to section L - Accessories.



Additional Options

Expansion Units Options

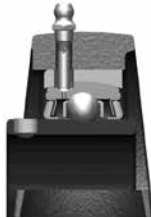

Axial shaft expansion is compensated by a non-expansion (fixed) and expansion (float) arrangement. Many bearings are offered in both fixed and float arrangements and have identical mounting dimensions. It is recommended to use both units on one shaft in high temperature applications to help account for linear shaft expansion. For more information see page G-249 in the Mounted Ball Bearing Engineering section.

Expansion Unit Availability Chart

Bore Diameter		Unit Size	Standard Duty				Expansion Capability
in	mm		ENP	ESP	ESF	ESFT	
5/8		10					
11/16		11	•		•	•	3/32"
3/4		12					
	20	204					
13/16		13					
7/8		14					
15/16		15	•	•	•	•	3/32"
	25	205					
1		16					
1 1/16		17					
1 1/8		18					
	30	206	•	•	•	•	1/8"
1 3/6		19					
1 1/4		20R					
1 1/4		20					
1 5/16		21					
1 3/8		22	•	•	•	•	1/8"
	35	207					
1 7/16		23					
1 1/2		24					
1 9/16		25	•		•	•	1/8"
	40	208					
1 5/8		26					
1 11/16		27	•		•	•	1/8"
1 3/4		28					
	45	209					
1 13/16		29					
1 7/8		30					
1 15/16		31	•	•	•	•	3/16"
	50	210					
2		32R					
2		32					
2 1/8		34	•	•	•	•	3/16"
	55	211					
2 3/16		35					
2 1/4		36					
	60	212	•	•	•		3/16"
2 3/8		38					
2 7/16		39					
2 1/2		40					
2 11/16		43		•	•		3/16"
	70	214					
2 7/8		46					
2 15/16		47			•		3/16"
	75	215					
3		48					
	80	216		•			1/4"
3 3/16		51					

Bore Diameter		Unit Size	Medium Duty							Expansion Capability	
in	mm		EMFP	EMFPD	EMP	EMSPD	EMSFPD	EMSF	EMSFT		EMFC
15/16		15									
	25	305			•				•	•	1/8"
1		16									
	30	306									
1 3/16		19			•				•	•	1/8"
1 1/4		20									
	35	307									
1 7/16		23			•				•	•	1/8"
1 1/2		24									
	40	308			•				•	•	1/8"
1 11/16		27									
1 3/4		28			•				•	•	3/16"
	45	309									
1 15/16		31									
	50	310			•	•			•	•	3/16"
2		32									
	55	311									
2 3/16		35			•				•		3/16"
2 1/4		36									
2 7/16		39									
2 1/2		40	•	•	•	•			•	•	3/16"
	65	313									
2 11/16		43	•	•	•				•		3/16"
	70	314									
2 15/16		47									
	75	315	•	•	•	•			•		1/4"
3		48									
	80	316									
3 3/16		51			•				•		1/4"
3 1/4		52									
3 7/16		55	•	•	•	•	•	•			9/32"
3 15/16		63									
	100	320	•	•	•	•	•	•			9/32"
4		64									
4 7/16		71	•	•				•	•		7/16"
4 15/16		79									

• Expansion option exists for the bearing and housing combination

Note: 1. Not all combinations of housing styles, locking types and seal options are available. Consult customer service for availability and possible set-up charges.

2. Alternate expansion version available in some sizes and configurations with half-dog and wire, suffix "HIY", see page G-104 for more information.



Additional Options

Greases

Optional greases are readily available, consult Application Engineering for complete list

High Temperature Synthetic

- Used in HT, HTA, and HTC suffix modified bearings
- High quality, synthetic hydrocarbon, lithium complex thickened grease NLGI#2, and ISO 220 viscosity
- Superior high temperature (200 F to 400F) stability

KRYTOX* Extended Lube

- Used in HI suffix modified bearings
- KRYTOX GPL 226, an extremely high performance perflourinated oil and PTFE thickened grease
- KRYTOX grease has a superior service life and therefore diminishes re-lubrication frequency and extends life
- Engineers have found that, compared to other high temperature greases, the thermal stability and lubricity of the KRYTOX can improve high temperature bearing life by a factor of 4 to 45 times

Custom Capabilities

Additional Industry specific options exist such as the:

- Sealmaster Paver Bearing – page G-127
- Sealmaster Material Handling Bearing - page G-109
- Sealmaster PN Gold – Corrosion Resistant – page K-29

Our Application Engineers will design a bearing based on your unique application parameters, utilizing a variety of existing components or special components. By combining your equipment knowledge and our Application Engineers bearing expertise, a product solution can be designed to maximize bearing performance in your specific application.

Thousands of customers benefit from this capability every year, and now you no longer have to endure the lead time associated with these custom engineered solutions. In many cases, a higher performance product can be designed and developed specifically for your application.

*KRYTOX is a registered trademark of E.I. du Pont de Nemurs and Company. This trade name, trademark and/or registered trademark is property of their respective owner and is not owned or controlled by Power Transmission Solutions.



- Duty:** Standard
- Rolling Elements:** Ball
- Housing:** Cast Iron Pillow Block – High Base
- Self Alignment:** +/- 2 Degrees
- Lock:** Setscrew
- Seal:** Felt
- Optional Seal:** Contact
- Temperature:** -20° to 220°F

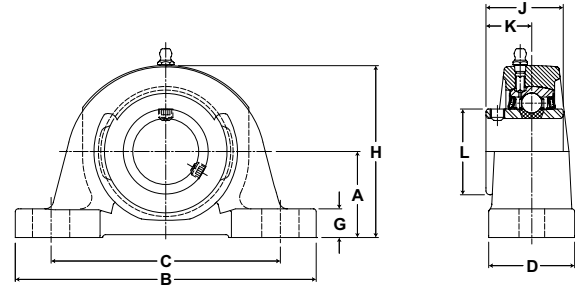

NP Series Standard Duty Pillow Blocks - Setscrew Locking

Bore Diameter		Part No.	Bearing Insert No.	Basic Dynamic Rating lb/N	Dimensions inch / mm								Bolt Size	Unit Wt. lb/kg		
inch	mm				A	B	C		D	G	H	J			K	L
						min.	max.									
1/2		NP-8	2-08		1 3/16	5	3 3/8	4 1/8	1 1/2	1/2	2 7/16	1 7/32	23/32	1 3/16	3/8	1.7
9/16		NP-9	2-09	2611	30.2	127.0	85.7	104.8	38.1	12.7	61.9	31.0	18.3	30.2		.77
5/8		NP-10	2-010	11614												
11/16		NP-11	2-011													
3/4	20	NP-12	2-012	2611	1 5/16	5	3 3/8	4 1/8	1 1/2	1/2	2 9/16	1 7/32	23/32	1 3/16	3/8	1.9
		NP-204	5204	11614	33.3	127.0	85.7	104.8	38.1	12.7	65.1	31.0	18.3	30.2		.86
13/16		NP-13	2-013													
7/8		NP-14	2-014	2801	1 7/16	5 1/2	3 7/8	4 3/8	1 1/2	1/2	2 13/16	1 3/8	13/16	1 3/8	3/8	2.2
15/16		NP-15	2-015	12459	36.5	139.7	98.4	111.1	38.1	12.7	71.4	34.9	20.6	34.9		1.00
1	25	NP-16	2-1													
		NP-205	5205													
1 1/16		NP-17	2-11													
1 1/8		NP-18	2-12	4381	1 11/16	6 1/2	4 7/16	5 1/16	1 7/8	9/16	3 3/8	1 1/2	7/8	1 19/32	1/2	3.6
1 3/16		NP-19	2-13	19487	42.9	165.1	112.7	128.6	47.6	14.3	85.7	38.1	22.2	40.5		1.63
1 1/4	30	NP-20R	1-14													
		NP-206	5206													
1 1/4		NP-20	2-14													
1 5/16		NP-21	2-15	5782	1 7/8	6 9/16	4 11/16	5 5/16	1 7/8	5/8	3 3/4	1 11/16	1	1 55/64	1/2	4.5
1 3/8		NP-22	2-16	25718	47.6	166.7	119.1	134.9	47.6	15.9	95.3	42.9	25.4	47.2		2.04
1 7/16	35	NP-23	2-17													
		NP-207	5207													
1 1/2		NP-24	2-18	7340	1 15/16	7 1/4	4 7/8	5 7/8	2 1/8	11/16	3 15/16	1 15/16	1 3/16	2 1/16	1/2	5.7
1 9/16	40	NP-25	2-19	32648	49.2	184.2	123.8	149.2	54.0	17.5	100.0	49.2	30.2	52.4		2.59
		NP-208	5208													
1 5/8		NP-26	2-110													
1 11/16		NP-27	2-111	7901	2 1/8	7 1/2	5 7/16	6 1/16	2 1/8	11/16	4 1/4	1 15/16	1 3/16	2 19/64	1/2	6.5
1 3/4	45	NP-28	2-112	35144	54.0	190.5	138.1	154.0	54.0	17.5	108.0	49.2	30.2	58.3		2.95
		NP-209	5209													
1 13/16		NP-29	2-113													
1 7/8		NP-30	2-114	7889	2 1/4	8 1/8	6	6 1/2	2 3/8	3/4	4 9/16	2 1/32	1 9/32	2 15/32	5/8	7.9
1 15/16		NP-31	2-115	35090	57.2	206.4	152.4	165.1	60.3	19.1	115.9	51.6	32.5	62.7		3.58
2	50	NP-32R	1-2													
		NP-210	5210													
2		NP-32	2-2													
2 1/8		NP-34	2-22	9752	2 1/2	8 5/8	6 1/2	7	2 3/8	3/4	5	2 3/16	1 5/16	2 23/32	5/8	9.7
2 3/16	55	NP-35	2-23	43377	63.5	219.1	165.1	177.8	60.3	19.1	127.0	55.6	33.3	69.1		4.40
		NP-211	5211													
2 1/4		NP-36	2-24													
2 3/8		NP-38	2-26	11789	2 3/4	9 1/2	6 7/8	7 5/8	2 3/4	7/8	5 9/16	2 9/16	1 9/16	2 63/64	5/8	13.7
2 7/16	60	NP-39	2-27	52437	69.9	241.3	174.6	193.7	69.9	22.2	141.3	65.1	39.7	75.8		6.21
		NP-212	5212													
2 7/8		NP-46	2-214	14839	3.5	13	8 1/2	9 1/2	3 1/2	1 1/8	7	3 1/16	1 3/4	3 41/64	7/8	27.9
2 15/16	75	NP-47	2-215	66004	88.9	330.2	215.9	241.3	88.9	28.6	177.8	77.8	44.5	92.5		12.66
		NP-215	5215													

For Standard Duty Bearing Inserts-Single Lock see page G-92.

Metric dimensions for reference only.

Not all parts are available from stock. Please contact customer service for availability (800) 626-2120.

For more information on bearing capabilities outside of our standard offering, please contact Application Engineering (800) 626-2093.

Performance Mounted Ball Bearings



Mtd. Ball Bearings



- Duty:** Standard
- Rolling Elements:** Ball
- Housing:** Cast Iron Pillow Block – High Base
- Self Alignment:** +/- 2 Degrees
- Lock:** SKWEZLOC Locking Collar
- Seal:** Felt
- Optional Seal:** Contact
- Temperature:** -20° to 220°F

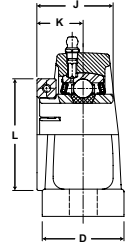
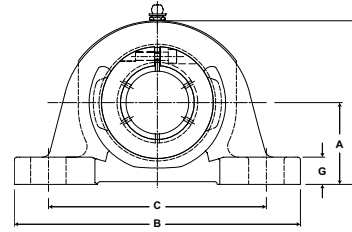

NP-T Series Standard Duty Pillow Block - SKWEZLOC Locking Collar - Inch

Bore Diameter inch	Part No.	Bearing Insert No.	Basic Dynamic Rating lb/N	Dimensions inch / mm										Bolt Size	Unit Wt. lb/kg
				A	B	C		D	G	H	J	K	L		
						min.	max.								
3/4	NP-12T	2-012T	2611 11614	1 5/16 33.3	5 127.0	3 3/8 85.7	4 1/8 104.8	1 1/2 38.1	1/2 12.7	2 9/16 65.1	1 9/32 32.5	25/32 19.8	1 3/4 44.5	3/8	2.0 .91
15/16 1	NP-15T NP-16T	2-015T 2-1T	2801 12459	1 7/16 36.5	5 1/2 139.7	3 7/8 98.4	4 3/8 111.1	1 1/2 38.1	1/2 12.7	2 13/16 71.4	1 7/16 36.5	7/8 22.2	1 15/16 49.2	3/8	2.4 1.09
1 1/8 1 3/16 1 1/4	NP-18T NP-19T NP-20RT	2-12T 2-13T 1-14T	4381 19487	1 11/16 42.9	6 1/2 165.1	4 7/16 112.7	5 1/16 128.6	1 7/8 47.6	9/16 14.3	3 3/8 85.7	1 9/16 39.7	15/16 23.8	2 3/16 55.6	1/2	3.8 1.72
1 1/4	NP-20T	2-14T	5782 25718	1 7/8 47.6	6 9/16 166.7	4 11/16 119.1	5 5/16 134.9	1 7/8 47.6	5/8 15.9	3 3/4 95.3	1 3/4 44.5	1 1/16 27.0	2 7/16 61.9	1/2	4.8 2.18
1 3/8 1 7/16	NP-22T NP-23T	2-16T 2-17T	4782 21270	1 7/8 47.6	6 9/16 166.7	4 11/16 119.1	5 5/16 134.9	1 7/8 47.6	5/8 15.9	3 3/4 95.3	1 3/4 44.5	1 1/16 27.0	2 9/16 65.1	1/2	4.8 2.18
1 1/2	NP-24T	2-18T	7340 32648	1 15/16 49.2	7 1/4 184.2	4 7/8 123.8	5 7/8 149.2	2 1/8 54.0	11/16 17.5	3 15/16 100.0	2 50.8	1 1/4 31.8	2 11/16 68.3	1/2	6.0 2.72
1 5/8	NP-26T	2-110T	7901 35144	2 1/8 54.0	7 1/2 190.5	5 7/16 138.1	6 1/16 154.0	2 1/8 54.0	11/16 17.5	4 1/4 108.0	2 50.8	1 1/4 31.8	2 13/16 71.4	1/2	6.8 3.08
1 11/16 1 3/4	NP-27T NP-28T	2-111T 2-112T	7901 35144	2 1/8 54.0	7 1/2 190.5	5 7/16 138.1	6 1/16 154.0	2 1/8 54.0	11/16 17.5	4 1/4 108.0	2 50.8	1 1/4 31.8	2 15/16 74.6	1/2	6.8 3.08
1 15/16 2	NP-31T NP-32RT	2-115T 1-2T	7889 35090	2 1/4 57.2	8 1/8 206.4	6 152.4	6 1/2 165.1	2 3/8 60.3	3/4 19.1	4 9/16 115.9	2 3/32 53.2	1 11/32 34.1	3 3/8 85.7	5/8	8.5 3.86
2	NP-32T	2-2T	9752 43377	2 1/2 63.5	8 5/8 219.1	6 1/2 165.1	7 177.8	2 3/8 60.3	3/4 19.1	5 127.0	2 1/4 57.2	1 3/8 34.9	3 1/2 88.9	5/8	10.3 4.67
2 1/8 2 3/16	NP-34T NP-35T	2-22T 2-23T	9752 43377	2 1/2 63.5	8 5/8 219.1	6 1/2 165.1	7 177.8	2 3/8 60.3	3/4 19.1	5 127.0	2 1/4 57.2	1 3/8 34.9	3 5/8 92.1	5/8	10.3 4.67
2 1/4	NP-36T	2-24T	11789 52437	2 3/4 69.9	9 1/2 241.3	6 7/8 174.6	7 5/8 193.7	2 3/4 69.9	7/8 22.2	5 9/16 141.3	2 5/8 66.7	1 5/8 41.3	4 1/16 103.2	5/8	14.9 6.76
2 3/8	NP-38T	2-26T	11789 52437	2 3/4 69.9	9 1/2 241.3	6 7/8 174.6	7 5/8 193.7	2 3/4 69.9	7/8 22.2	5 9/16 141.3	2 5/8 66.7	1 5/8 41.3	4 1/8 104.8	5/8	14.9 6.76

NP-T Series Standard Duty Pillow Block - SKWEZLOC Locking Collar - Metric -SKWEZ™

Bore Diameter mm	Part No.	Bearing Insert No.	Basic Dynamic Rating N/lb	Dimensions mm / inch										Bolt Size	Unit Wt. lb/kg
				A	B	C		D	G	H	J	K	L		
						min.	max.								
20	NP-204TMC	5204TMC	11614 4782	33.3 1 5/16	127.0 5	85.7 3 3/8	104.8 4 1/8	38.2 1 1/2	12.7 1/2	65.1 2 9/16	32.5 1 9/32	19.8 25/32	44.5 1 3/4	M10	.91 4.8
25	NP-205TMC	5205TMC	19487 2801	36.5 1 7/16	139.7 5 1/2	98.4 3 7/8	111.1 4 3/8	38.1 1 1/2	12.7 1/2	71.4 2 13/16	36.5 1 7/16	22.2 7/8	49.2 1 15/16	M10	1.1 2.4
30	NP-206TMC	5206TMC	19487 4381	42.9 1 11/16	165.1 6 1/2	112.7 4 7/16	128.6 5 1/16	47.6 1 7/8	14.3 9/16	85.7 3 3/8	39.7 1 9/16	23.8 15/16	55.6 2 3/16	M10	1.72 3.8
35	NP-207TMC	5207TMC	21270 4782	47.6 1 7/8	166.7 6 9/16	119.1 4 11/16	134.9 5 5/16	47.6 1 7/8	15.9 5/8	95.3 3 3/4	44.5 1 3/4	27.0 1 1/16	65.1 2 9/16	M10	2.18 4.8
40	NP-208TMC	5208TMC	32648 7340	49.2 1 15/16	184.2 7 1/4	123.8 4 7/8	149.2 5 7/8	54.0 2 1/8	17.5 11/16	100.0 3 15/16	54.8 2 5/32	31.8 1 1/4	68.3 2 11/16	M14	2.72 6.0
45	NP-209TMC	5209TMC	35144 7901	54.0 2 1/8	190.5 7 1/2	138.1 5 7/16	154.0 6 1/16	54.0 2 1/8	17.5 11/16	108.0 4 1/4	50.8 2	31.8 1 1/4	74.6 2 15/16	M14	3.08 6.8
50	NP-210TMC	5210TMC	35090 7889	57.2 2 1/4	206.4 8 1/8	152.4 6	165.1 6 1/2	60.3 2 3/8	19.1 3/4	115.9 4 9/16	53.2 2 3/32	34.1 1 11/32	85.7 3 3/8	M16	3.86 8.5
55	NP-211TMC	5211TMC	43377 9752	63.5 2 1/2	219.1 8 5/8	165.1 6 1/2	177.8 7	60.3 2 3/8	19.1 3/4	127.0 5	57.2 2 1/4	34.9 1 3/8	92.1 3 5/8	M16	4.67 10.3
60	NP-212TMC	5212TMC	11789 52437	69.9 2 3/4	241.3 9 1/2	174.6 6 7/8	193.7 7 5/8	69.9 2 3/4	22.2 7/8	141.3 5 9/16	66.7 2 5/8	41.3 1 5/8	104.8 4 1/8	M16	6.8 14.9

For Standard Duty Bearing Inserts - SKWEZLOC Locking Collar see page G-93.

SEALMASTER® Performance Mounted Ball Bearings



Duty:	Standard
Rolling Elements:	Ball
Housing:	Cast Iron Pillow Block – High Base
Self Alignment:	+/- 2 Degrees
Lock:	Double Setscrew
Seal:	Felt
Optional Seal:	Contact
Temperature:	-20° to 220°F

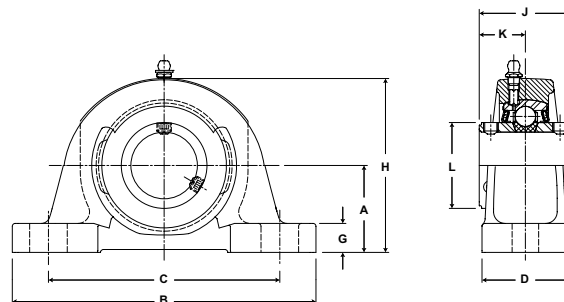

NPD Series Standard Duty Pillow Blocks With Double Lock - Setscrew Locking

Bore Diameter inch	Part No.	Bearing Insert No.	Basic Dynamic Rating lb/N	Dimensions inch / mm										Bolt Size	Unit Wt. lb/kg
				A	B	C		D	G	H	J	K	L		
						min.	max.								
7/8	NPD-14	2-014D	2801	1 7/16	5 1/2	3 7/8	4 3/8	1 1/2	1/2	2 13/16	1 1/2	3/4	1 3/8	3/8	2.4
15/16	NPD-15	2-015D	12459	36.5	139.7	98.4	111.1	38.1	12.7	71.4	38.1	19.1	34.9		1.09
1	NPD-16	2-1D													
1 3/16	NPD-19	2-13D	4381	1 11/16	6 1/2	4 7/16	5 1/16	1 7/8	9/16	3 3/8	1 3/4	7/8	1 19/32	1/2	3.8
			19487	42.9	165.1	112.7	128.6	47.6	14.3	85.7	44.5	22.2	40.5		1.72
1 1/4	NPD-20	2-14D	5782	1 7/8	6 9/16	4 11/16	5 5/16	1 7/8	5/8	3 3/4	2	1	1 55/64	1/2	4.7
1 3/8	NPD-22	2-16D	25718	47.6	166.7	119.1	134.9	47.6	15.9	95.3	50.8	25.4	47.2		2.13
1 7/16	NPD-23	2-17D													
1 1/2	NPD-24	2-18D	7340	1 15/16	7 1/4	4 7/8	5 7/8	2 1/8	11/16	3 15/16	2 5/16	1 5/32	2 1/16	1/2	6.0
1 9/16	NPD-25	2-19D	32648	49.2	184.2	123.8	149.2	54.0	17.5	100.0	58.7	29.4	52.4		2.73
1 11/16	NPD-27	2-111D	7901	2 1/8	7 1/2	5 7/16	6 1/16	2 1/8	11/16	4 1/4	2 3/8	1 3/16	2 19/64	1/2	6.5
1 3/4	NPD-28	2-112D	35144	54.0	190.5	138.1	154.0	54.0	17.5	108.0	60.3	30.2	58.3		2.95
1 7/8	NPD-30	2-114D	7889	2 1/4	8 1/8	6	6 1/2	2 3/8	3/4	4 9/16	2 1/2	1 1/4	2 15/32	5/8	8.3
1 15/16	NPD-31	2-115D	35090	57.2	206.4	152.4	165.1	60.3	19.1	115.9	63.5	31.8	62.7		3.76
2	NPD-32	2-2D	9752	2 1/2	8 5/8	6 1/2	7	2 3/8	3/4	5	2 5/8	1 5/16	2 23/32	5/8	10.0
2 1/8	NPD-34	2-22D	43377	63.5	219.1	165.1	177.8	60.3	19.1	127.0	66.7	33.3	69.1		4.54
2 3/16	NPD-35	2-23D													
2 1/4	NPD-36	2-24D	11789	2 3/4	9 1/2	6 7/8	7 5/8	2 3/4	7/8	5 9/16	3 1/8	1 9/16	2 63/64	5/8	14.0
2 3/8	NPD-38	2-26D	52437	69.9	241.3	174.6	193.7	69.9	22.2	141.3	79.4	39.7	75.8		6.35
2 7/16	NPD-39	2-27D													

For Standard Duty Bearing Inserts-Double Lock see page G-94.

Metric dimensions for reference only.

Not all parts are available from stock. Please contact customer service for availability (800) 626-2120.

For more information on bearing capabilities outside of our standard offering, please contact Application Engineering (800) 626-2093.

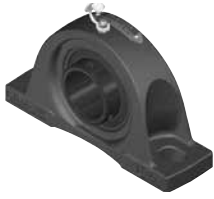

- Duty:** Standard
- Rolling Elements:** Ball
- Housing:** Cast Iron Pillow Block – Low Base
- Self Alignment:** +/- 2 Degrees
- Lock:** Setscrew
- Seal:** Felt
- Optional Seal:** Contact
- Temperature:** -20° to 220°F

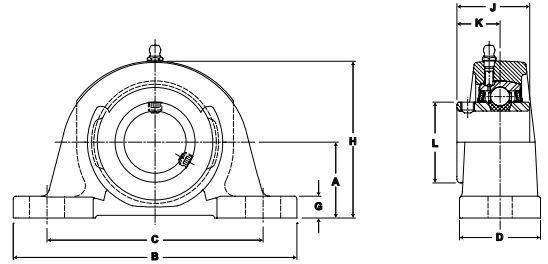

NPL Series Standard Duty Pillow Blocks - Setscrew Locking

Bore Diameter		Part No.	Bearing Insert No.	Basic Dynamic Rating lb/N	Dimensions inch / mm								Bolt Size	Unit Wt. lb/kg		
inch	mm				A	B	C		D	G	H	J			K	L
						min.	max.									
1/2		NPL-8	2-08	2611	1 1/16	5	3 3/8	4 1/8	1 1/2	3/8	2 5/16	1 7/32	23/32	1 3/16	3/8	1.7 .77
9/16		NPL-9	2-09		27.0	127.0	85.7	104.8	38.1	9.5	58.7	31.0	18.3	30.2		
5/8		NPL-10	2-010		11614											
11/16		NPL-11	2-011													
3/4		NPL-12	2-012	2611	1 1/4	5	3 3/8	4 1/8	1 1/2	7/16	2 1/2	1 7/32	23/32	1 3/16	3/8	1.7 .77
	20	NPL-204	5204		31.8	127.0	85.7	104.8	38.1	11.1	63.5	31.0	18.3	30.2		
13/16		NPL-13	2-013	2801 12459	1 5/16	5 1/2	3 7/8	4 3/8	1 1/2	1/2	2 11/16	1 3/8	13/16	1 3/8	3/8	2.0 .91
7/8		NPL-14	2-014		33.3	139.7	98.4	111.1	38.1	12.7	68.3	34.9	20.6	34.9		
15/16		NPL-15	2-015													
1		NPL-16	2-1		12459											
	25	NPL-205	5205													
1 1/16		NPL-17	2-11	4381 19487	1 9/16	6 1/2	4 7/16	5 1/16	1 7/8	7/16	3 1/4	1 1/2	7/8	1 19/32	1/2	3.6 1.63
1 1/8		NPL-18	2-12		39.7	165.1	112.7	128.6	47.6	11.1	82.6	38.1	22.2	40.5		
1 3/16		NPL-19	2-13													
1 3/8		NPL-20R	1-14		19487											
1 1/4		NPL-206	5206													
1 1/4		NPL-20	2-14	5782 25718	1 13/16	6 9/16	4 11/16	5 5/16	1 7/8	9/16	3 11/16	1 11/16	1	1 55/64	1/2	4.4 2.00
1 5/16		NPL-21	2-15		46.0	166.7	119.1	134.9	47.6	14.3	93.7	42.9	25.4	47.2		
1 3/8		NPL-22	2-16													
1 7/16		NPL-23	2-17		25718											
	35	NPL-207	5207													
1 1/2		NPL-24	2-18	7340 32648	1 15/16	7 1/4	4 7/8	5 7/8	2 1/8	11/16	3 15/16	1 15/16	1 3/16	2 1/16	1/2	5.7 2.59
1 9/16		NPL-25	2-19		49.2	184.2	123.8	149.2	54.0	17.5	100.0	49.2	30.2	52.4		
	40	NPL-208	5208													
1 5/8		NPL-26	2-110	7901 35144	2 1/16	7 1/2	5 7/16	6 1/16	2 1/8	5/8	4 3/16	1 15/16	1 3/16	2 19/64	1/2	6.2 2.81
1 11/16		NPL-27	2-111		52.4	190.5	138.1	154.0	54.0	15.9	106.4	49.2	30.2	58.3		
1 3/4		NPL-28	2-112													
	45	NPL-209	5209													
1 13/16		NPL-29	2-113	7889 35090	2 3/16	8 1/8	6	6 1/2	2 3/8	11/16	4 1/2	2 1/32	1 9/32	2 15/32	5/8	7.8 3.54
1 7/8		NPL-30	2-114		55.6	206.4	152.4	165.1	60.3	17.5	114.3	51.6	32.5	62.7		
1 15/16		NPL-31	2-115													
2		NPL-32R	1-2		35090											
	50	NPL-210	5210													
2		NPL-32	2-2	9752 43377	2 7/16	8 5/8	6 1/2	7	2 3/8	11/16	4 15/16	2 3/16	1 5/16	2 23/32	5/8	9.6 4.35
2 1/8		NPL-34	2-22		61.9	219.1	165.1	177.8	60.3	17.5	125.4	55.6	33.3	69.1		
2 3/16		NPL-35	2-23													
	55	NPL-211	5211													
2 1/4		NPL-36	2-24	11789 52437	2 11/16	9 1/2	6 7/8	7 5/8	2 3/4	13/16	5 1/2	2 9/16	1 9/16	2 63/64	5/8	13.5 6.12
2 3/8		NPL-38	2-26		68.3	241.3	174.6	193.7	69.9	20.6	139.7	65.1	39.7	75.8		
2 7/16		NPL-39	2-27													
	60	NPL-212	5212													
2 11/16		NPL-43	2-211	13971 62143	3 76.2	11 1/4 285.8	7 1/8 181.0	8 7/8 225.4	3 1/4 82.6	1 1/16 27.0	6 1/4 158.8	2 3/4 69.9	1 11/16 42.9	3 7/16 87.3	3/4	21.5 9.75

For Standard Duty Bearing Inserts-Single Lock see page G-92.

SEALMASTER® Performance Mounted Ball Bearings



Duty: Standard
Rolling Elements: Ball
Housing: Cast Iron Pillow Block – Low Base
Self Alignment: +/- 2 Degrees
Lock: SKWEZLOC Locking Collar
Seal: Felt
Optional Seal: Contact
Temperature: -20° to 220°F

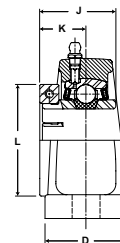
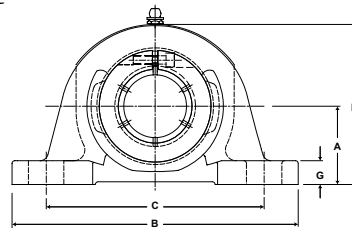

NPL-T Series Standard Duty Pillow Block - SKWEZLOC Locking Collar

Bore Diameter inch	Part No.	Bearing Insert No.	Basic Dynamic Rating lb/N	Dimensions inch / mm										Bolt Size	Unit Wt. lb/kg
				A	B	C		D	G	H	J	K	L		
						min.	max.								
3/4	NPL-12T	2-012T	2611	1 1/4	5	3 3/8	4 1/8	1 1/2	7/16	2 1/2	1 9/32	25/32	1 3/4	3/8	1.8 .82
			11614	31.8	127.0	85.7	104.8	38.1	11.1	63.5	32.5	19.8	44.5		
15/16	NPL-15T	2-015T	2801	1 5/16	5 1/2	3 7/8	4 3/8	1 1/2	1/2	2 11/16	1 7/16	7/8	1 15/16	3/8	2.2 1.00
			12459	33.3	139.7	98.4	111.1	38.1	12.7	68.3	36.5	22.2	49.2		
1 1/8	NPL-18T	2-12T	4381 19487	1 9/16	6 1/2	4 7/16	5 1/16	1 7/8	7/16	3 1/4	1 9/16	15/16	2 3/16	1/2	3.8 1.72
1 3/16	NPL-19T	2-13T		39.7	165.1	112.7	128.6	47.6	11.1	82.6	39.7	23.8	55.6		
1 1/4	NPL-20RT	1-14T													
1 1/4	NPL-20T	2-14T	5782	1 13/16	6 9/16	4 11/16	5 5/16	1 7/8	9/16	3 11/16	1 3/4	1 1/16	2 7/16	1/2	4.7 2.13
			25718	46.0	166.7	119.1	134.9	47.6	14.3	93.7	44.5	27.0	61.9		
1 3/8	NPL-22T	2-16T	5782	1 13/16	6 9/16	4 11/16	5 5/16	1 7/8	9/16	3 11/16	1 3/4	1 1/16	2 9/16	1/2	4.7 2.13
			25718	46.0	166.7	119.1	134.9	47.6	14.3	93.7	44.5	27.0	65.1		
1 1/2	NPL-24T	2-18T	7340	1 15/16	7 1/4	4 7/8	5 7/8	2 1/8	11/16	3 15/16	2	1 1/4	2 11/16	1/2	6.0 2.72
			32648	49.2	184.2	123.8	149.2	54.0	17.5	100.0	50.8	31.8	68.3		
1 5/8	NPL-26T	2-110T	7901	2 1/16	7 1/2	5 7/16	6 1/16	2 1/8	5/8	4 3/16	2	1 1/4	2 13/16	1/2	6.5 2.95
			35144	52.4	190.5	138.1	154.0	54.0	15.9	106.4	50.8	31.8	71.4		
1 11/16	NPL-27T	2-111T	7901	2 1/16	7 1/2	5 7/16	6 1/16	2 1/8	5/8	4 3/16	2	1 1/4	2 15/16	1/2	6.5 2.95
			35144	52.4	190.5	138.1	154.0	54.0	15.9	106.4	50.8	31.8	74.6		
1 15/16	NPL-31T	2-115T	7889	2 3/16	8 1/8	6	6 1/2	2 3/8	11/16	4 1/2	2 3/32	1 11/32	3 3/8	5/8	8.4 3.81
			35090	55.6	206.4	152.4	165.1	60.3	17.5	114.3	53.2	34.1	85.7		
2	NPL-32T	2-2T	9752	2 7/16	8 5/8	6 1/2	7	2 3/8	11/16	4 15/16	2 1/4	1 3/8	3 1/2	5/8	10.2 4.63
			43377	61.9	219.1	165.1	177.8	60.3	17.5	125.4	57.2	34.9	88.9		
2 1/8	NPL-34T	2-22T	9752	2 7/16	8 5/8	6 1/2	7	2 3/8	11/16	4 15/16	2 1/4	1 3/8	3 5/8	5/8	10.2 4.63
			43377	61.9	219.1	165.1	177.8	60.3	17.5	125.4	57.2	34.9	92.1		
2 1/4	NPL-36T	2-24T	11789	2 11/16	9 1/2	6 7/8	7 5/8	2 3/4	13/16	5 1/2	2 5/8	1 5/8	4 1/16	5/8	14.7 6.67
			52437	68.3	241.3	174.6	193.7	69.9	20.6	139.7	66.7	41.3	103.2		
2 3/8	NPL-38T	2-26T	11789	2 11/16	9 1/2	6 7/8	7 5/8	2 3/4	13/16	5 1/2	2 5/8	1 5/8	4 1/8	5/8	14.7 6.67
			52437	68.3	241.3	174.6	193.7	69.9	20.6	139.7	66.7	41.3	104.8		

For Standard Duty SKWEZLOC Locking Collar Bearing inserts see page G-93.

Metric dimensions for reference only.

Not all parts are available from stock. Please contact customer service for availability (800) 626-2120.

For more information on bearing capabilities outside of our standard offering, please contact Application Engineering (800) 626-2093.

Performance Mounted Ball Bearings



Mtd. Ball Bearings

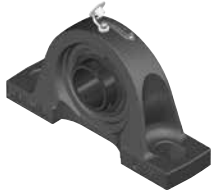

- Duty:** Standard
- Rolling Elements:** Ball
- Housing:** Cast Iron Pillow Block – Heavy Duty
- Self Alignment:** +/- 2 Degrees
- Lock:** Setscrew
- Seal:** Felt
- Optional Seal:** Contact
- Temperature:** -20° to 220°F

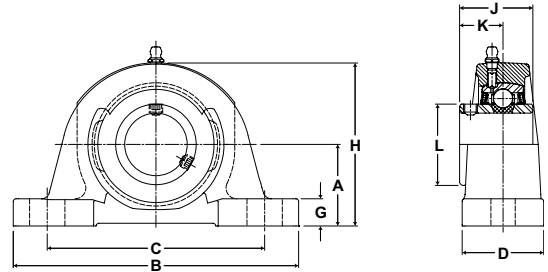

SP Series Standard Duty Pillow Blocks - Setscrew Locking

Bore Diameter		Part No.	Bearing Insert No.	Basic Dynamic Rating lb/N	Dimensions inch / mm										Bolt Size	Unit Wt. lb/kg
inch	mm				A	B	C		D	G	H	J	K	L		
						min.	max.									
13/16		SP-13	2-013	2801 12459	1 3/4 44.5	7 177.8	5 1/8 130.2	5 5/8 142.9	2 50.8	9/16 14.3	3 5/16 84.1	1 3/8 34.9	13/16 20.6	1 3/8 34.9	1/2	3.6 1.63
7/8		SP-14	2-014													
15/16		SP-15	2-015													
1	25	SP-16 SP-205	2-1 5205													
1 1/16		SP-17	2-11	4381 19487	2 50.8	7 1/2 190.5	5 3/8 136.5	6 1/8 155.6	2 50.8	5/8 15.9	3 7/8 98.4	1 1/2 38.1	7/8 22.2	1 19/32 40.5	1/2	5.0 2.27
1 1/8		SP-18	2-12													
1 3/16		SP-19	2-13													
1 1/4	30	SP-20R SP-206	2-14 5206													
1 1/4		SP-20	2-14	5782	2 3/8 60.3	8 1/4 209.6	5 5/8 142.9	6 7/8 174.6	2 1/4 57.2	3/4 19.1	4 1/2 114.3	1 11/16 42.9	1 25.4	1 55/64 47.2	5/8	7.0 3.18
1 5/16		SP-21	2-15													
1 3/8		SP-22	2-16													
1 7/16	35	SP-23 SP-207	2-17 5207													
1 1/2		SP-24	2-18	7340 32648	2 5/16 58.7	8 1/2 215.9	5 7/8 149.2	7 1/8 181.0	2 3/8 60.3	3/4 19.1	4 9/16 115.9	1 15/16 49.2	1 3/16 30.2	2 1/16 52.4	5/8	7.6 3.45
1 9/16	40	SP-25	2-19													
		SP-208	5208													
1 5/8		SP-26	2-110	7901 35144	2 3/8 60.3	8 3/4 222.3	5 7/8 149.2	7 1/8 181.0	2 3/8 60.3	3/4 19.1	4 5/8 117.5	1 15/16 49.2	1 3/16 30.2	2 19/64 58.3	5/8	8.1 3.67
1 11/16		SP-27	2-111													
1 3/4	45	SP-28	2-112													
		SP-209	5209													
1 13/16		SP-29	2-113	7889 35090	2 3/4 69.9	10 1/2 266.7	6 3/4 171.5	8 1/2 215.9	2 1/2 63.5	7/8 22.2	5 5/16 134.9	2 1/32 51.6	1 9/32 32.5	2 15/32 62.7	5/8	11.6 5.26
1 7/8		SP-30	2-114													
1 15/16		SP-31	2-115													
2	50	SP-32R SP-210	1-2 5210													
2		SP-32	2-2	9752 43377	3 1/8 79.4	11 1/4 285.8	7 5/8 193.7	9 3/8 238.1	2 3/4 69.9	7/8 22.2	5 15/16 150.8	2 3/16 55.6	1 5/16 33.3	2 23/32 69.1	5/8	14.1 6.40
2 1/8		SP-34	2-22													
2 3/16	55	SP-35	2-23													
		SP-211	5211													
2 1/4		SP-36	2-24	11789 52437	3 1/8 79.4	11 1/2 292.1	7 7/8 200.0	9 3/8 238.1	3 76.2	7/8 22.2	6 1/16 154.0	2 9/16 65.1	1 9/16 39.7	2 63/64 75.8	3/4	16.5 7.48
2 3/8		SP-38	2-26													
2 7/16	60	SP-39	2-27													
		SP-212	5212													
2 1/2		SP-40	3-28	13971 62143	3 3/4 95.3	12 5/8 320.7	9 3/8 238.1	10 5/8 269.9	3 3/8 85.7	1 25.4	7 1/8 181.0	2 3/4 69.9	1 11/16 42.9	3 7/16 87.3	3/4	26.3 11.93
2 11/16	70	SP-43	2-211													
		SP-214	5214													
2 7/8		SP-46	2-214	14839 66004	3 3/4 95.3	13 330.2	9 1/4 235.0	10 3/4 273.1	3 3/8 85.7	1 25.4	7 3/16 182.6	3 1/16 77.8	1 3/4 44.5	3 41/64 92.5	3/4	26.6 12.07
2 15/16	75	SP-47	2-215													
		SP-215	5215													
3		SP-48	3-3	17412 77449	4 101.6	14 1/2 368.3	10 5/8 269.9	12 1/8 308.0	3 3/4 95.3	1 1/8 28.6	7 13/16 198.4	3 1/4 82.6	1 15/16 49.2	3 59/64 99.6	3/4	34.0 15.42
3 3/16	80	SP-51	2-33													
		SP-216	5216													
3 1/4		SP-52	2-34	18681 83093	4 101.6	15 381.0	9 5/8 244.5	11 7/8 301.6	4 1/4 108.0	1 1/4 31.8	8 1/16 204.8	3 3/8 85.7	2 1/32 51.6	4 5/32 105.6	7/8	42.1 19.10
3 3/8		SP-54	2-36													
3 7/16		SP-55	2-37													

For Standard Duty Bearing Inserts-Single Lock see page G-93.

SEALMASTER® Performance Mounted Ball Bearings



Duty:	Standard
Rolling Elements:	Ball
Housing:	Cast Iron Pillow Block – Heavy Duty
Self Alignment:	+/- 2 Degrees
Lock:	SKWEZLOC Locking Collar
Seal:	Felt
Optional Seal:	Contact
Temperature:	-20° to 220°F

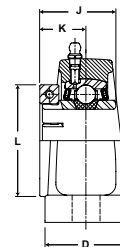
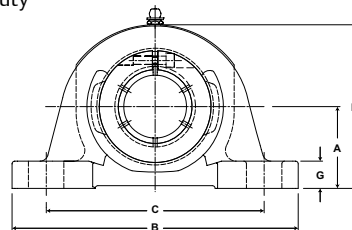

SP-T Series Standard Duty Pillow Blocks - SKWEZLOC Locking Collar

Bore Diameter inch	Part No.	Bearing Insert No.	Basic Dynamic Rating lb/N	Dimensions inch / mm										Bolt Size	Unit Wt. lb/kg
				A	B	C		D	G	H	J	K	L		
						min.	max.								
15/16	SP-15T	2-015T	2801	1 3/4	7	5 1/8	5 5/8	2	9/16	3 5/16	1 7/16	7/8	1 15/16	1/2	3.8
1	SP-16T	2-1T	12459	44.5	177.8	130.2	142.9	50.8	14.3	84.1	36.5	22.2	49.2		1.72
1 1/8	SP-18T	2-12T	4381 19487	2 50.8	7 1/2 190.5	5 3/8 136.5	6 1/8 155.6	2 50.8	5/8 15.9	3 7/8 98.4	1 9/16 39.7	15/16 23.8	2 3/16 55.6	1/2	5.2 2.36
1 3/16	SP-19T	2-13T													
1 1/4	SP-20RT	1-14T													
1 1/4	SP-20T	2-14T	5782 25718	2 3/8 60.3	8 1/4 209.6	5 5/8 142.9	6 7/8 174.6	2 1/4 57.2	3/4 19.1	4 1/2 114.3	1 3/4 44.5	1 1/16 27.0	2 7/16 61.9	5/8	7.3 3.31
1 3/8	SP-22T	2-16T	5782 25718	2 3/8 60.3	8 1/4 209.6	5 5/8 142.9	6 7/8 174.6	2 1/4 57.2	3/4 19.1	4 1/2 114.3	1 3/4 44.5	1 1/16 27.0	2 9/16 65.1	5/8	7.3 3.31
1 7/16	SP-23T	2-17T													
1 1/2	SP-24T	2-18T	7340 32648	2 5/16 58.7	8 1/2 215.9	5 7/8 149.2	7 1/8 181.0	2 3/8 60.3	3/4 19.1	4 9/16 115.9	2 50.8	1 1/4 31.8	2 11/16 68.3	5/8	7.3 3.31
1 5/8	SP-26T	2-110T	7901 35144	2 3/8 60.3	8 3/4 222.3	5 7/8 149.2	7 1/8 181.0	2 3/8 60.3	3/4 19.1	4 5/8 117.5	2 50.8	1 1/4 31.8	2 13/16 71.4	5/8	8.4 3.81
1 11/16	SP-27T	2-111T	7901 35144	2 3/8 60.3	8 3/4 222.3	5 7/8 149.2	7 1/8 181.0	2 3/8 60.3	3/4 19.1	4 5/8 117.5	2 50.8	1 1/4 31.8	2 15/16 74.6	5/8	8.4 3.81
1 3/4	SP-28T	2-112T													
1 15/16	SP-31T	2-115T	7889 35090	2 3/4 69.9	10 1/2 266.7	6 3/4 171.5	8 1/2 215.9	2 1/2 63.5	7/8 22.2	5 5/16 134.9	2 3/32 53.2	1 11/32 34.1	3 3/8 85.7	5/8	12.2 5.53
2	SP-32RT	1-2T													
2	SP-32T	2-2T	9752 43377	3 1/8 79.4	11 1/4 285.8	7 5/8 193.7	9 3/8 238.1	2 3/4 69.9	7/8 22.2	5 15/16 150.8	2 1/4 57.2	1 3/8 34.9	3 1/2 88.9	5/8	14.7 6.67
2 1/8	SP-34T	2-22T	9752 43377	3 1/8 79.4	11 1/4 285.8	7 5/8 193.7	9 3/8 238.1	2 3/4 69.9	7/8 22.2	5 15/16 150.8	2 1/4 57.2	1 3/8 34.9	3 5/8 92.1	5/8	14.7 6.67
2 3/16	SP-35T	2-23T													
2 1/4	SP-36T	2-24T	11789 52437	3 1/8 79.4	11 1/2 292.1	7 7/8 200.0	9 3/8 238.1	3 76.2	7/8 22.2	6 1/16 154.0	2 5/8 66.7	1 5/8 41.3	4 1/16 103.2	3/4	17.7 8.03
2 3/8	SP-38T	2-26T	11789 52437	3 1/8 79.4	11 1/2 292.1	7 7/8 200.0	9 3/8 238.1	3 76.2	7/8 22.2	6 1/16 154.0	2 5/8 66.7	1 5/8 41.3	4 1/8 104.8	3/4	17.7 8.03
2 7/16	SP-39T	2-27T													

For Standard Duty SKWEZLOC Locking Collar Bearing Inserts see page G-93.

Metric dimensions for reference only.

Not all parts are available from stock. Please contact customer service for availability (800) 626-2120.

For more information on bearing capabilities outside of our standard offering, please contact Application Engineering (800) 626-2093.

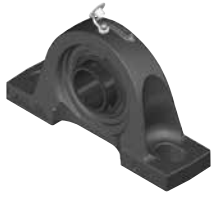

- Duty:** Standard
- Rolling Elements:** Ball
- Housing:** Cast Iron Pillow Block – Heavy Duty
- Self Alignment:** +/- 2 Degrees
- Lock:** Double Setscrew
- Seal:** Felt
- Optional Seal:** Contact
- Temperature:** -20° to 220°F

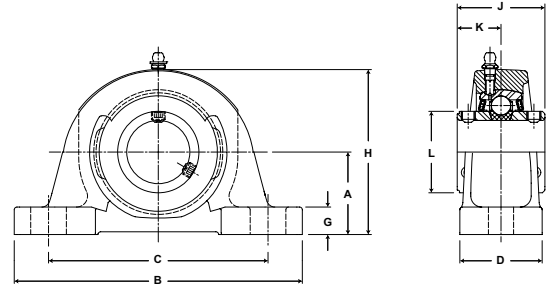

SPD Series Standard Duty Pillow Blocks With Double Lock - Setscrew Locking

Bore Diameter inch	Part No.	Bearing Insert No.	Basic Dynamic Rating lb/N	Dimensions inch / mm										Bolt Size	Unit Wt. lb/kg
				A	B	C		D	G	H	J	K	L		
						min.	max.								
7/8	SPD-14	2-014D	2801 12459	1 3/4	7	5 1/8	5 5/8	2	9/16	3 5/16	1 1/2	3/4	1 3/8	1/2	3.6 1.63
15/16	SPD-15	2-015D		44.5	177.8	130.2	142.9	50.8	14.3	84.1	38.1	19.1	34.9		
1	SPD-16	2-1D													
1 3/16	SPD-19	2-13D	4381 19487	2	7 1/2	5 3/8	6 1/8	2	5/8	3 7/8	1 3/4	7/8	1 19/32	1/2	5 2.27
1 1/4	SPD-20	2-14D	5782 25718	2 3/8	8 1/4	5 5/8	6 7/8	2 1/4	3/4	4 1/2	2	1	1 55/64	5/8	7.2 3.27
1 3/8	SPD-22	2-16D		60.3	209.6	142.9	174.6	57.2	19.1	114.3	50.8	25.4	47.2		
1 7/16	SPD-23	2-17D													
1 1/2	SPD-24	2-18D	7340	2 5/16	8 1/2	5 7/8	7 1/8	2 3/8	3/4	4 9/16	2 5/16	1 5/32	2 1/16	5/8	7.7 3.49
1 9/16	SPD-25	2-19D	32648	58.7	215.9	149.2	181.0	60.3	19.1	115.9	58.7	29.4	52.4		
1 11/16	SPD-27	2-111D	7901	2 3/8 60.3	8 3/4 222.3	5 7/8 149.2	7 1/8 181.0	2 3/8 60.3	3/4 19.1	4 5/8 117.5	2 3/8 60.3	1 3/16 30.2	2 19/64 58.3	5/8	8.3 3.76
1 3/4	SPD-28	2-112D	35144												
1 7/8	SPD-30	2-114D	7889	2 3/4	10 1/2	6 3/4	8 1/2	2 1/2	7/8	5 5/16	2 1/2	1 1/4	2 15/32	5/8	11.6 5.26
1 15/16	SPD-31	2-115D	35090	69.9	266.7	171.5	215.9	63.5	22.2	134.9	63.5	31.8	62.7		
2	SPD-32	2-2D	9752 43377	3 1/8	11 1/4	7 5/8	9 3/8	2 3/4	7/8	5 15/16	2 5/8	1 5/16	2 23/32	5/8	14.1 6.40
2 1/8	SPD-34	2-22D		79.4	285.8	193.7	238.1	69.9	22.2	150.8	66.7	33.3	69.1		
2 3/16	SPD-35	2-23D													
2 1/4	SPD-36	2-24D	11789 52437	3 1/8	11 1/2	7 7/8	9 3/8	3	7/8	6 1/16	3 1/8	1 9/16	2 63/64	3/4	17 7.71
2 3/8	SPD-38	2-26D		79.4	292.1	200.0	238.1	76.2	22.2	154.0	79.4	39.7	75.8		
2 7/16	SPD-39	2-27D													
2 1/2	SPD-40	3-28D	13971	3 3/4	12 5/8	9 3/8	10 5/8	3 3/8	1	7 1/8	3 1/2	1 3/4	3 7/16	3/4	26.8 12.16
2 11/16	SPD-43	2-211D	62143	95.3	320.7	238.1	269.9	85.7	25.4	181.0	88.9	44.5	87.3		
2 7/8	SPD-46	2-214D	14839	3 3/4	13	9 1/4	10 3/4	3 3/8	1	7 3/16	3 1/2	1 3/4	3 41/64	3/4	26.8 12.16
2 15/16	SPD-47	2-215D	66004	95.3	330.2	235.0	273.1	85.7	25.4	182.6	88.9	44.5	92.5		
3	SPD-48	3-3D	17412	4	14 1/2	10 5/8	12 1/8	3 3/4	1 1/8	7 13/16	3 7/8	1 15/16	3 59/64	3/4	34.5 15.65
3 3/16	SPD-51	2-33D	77449	101.6	368.3	269.9	308.0	95.3	28.6	198.4	98.4	49.2	99.6		

For Standard Duty Bearing Inserts-Double Lock see page G-94.



- Duty:** Medium
- Rolling Elements:** Ball
- Housing:** Cast Iron Pillow Block - High Base
- Self Alignment:** +/- 2 Degrees
- Lock:** Setscrew
- Seal:** Felt
- Optional Seal:** Contact
- Temperature:** -20° to 220°F

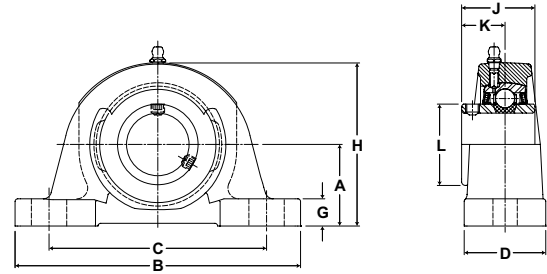

MP Series Medium Duty Pillow Blocks - Setscrew Locking

Bore Diameter		Part No.	Bearing Insert No.	Basic Dynamic Rating lb/N	Dimensions inch / mm										Bolt Size	Unit Wt. lb/kg
inch	mm				A	B	C		D	G	H	J	K	L		
						min.	max.									
15/16 1	25	MP-15	3-015	4381	1 3/4	6 1/4	4 3/16	5 3/16	2	5/8	3 7/16	1 1/2	7/8	1 19/32	1/2	4.0
		MP-16	3-1	19487	44.5	158.8	106.4	131.8	50.8	15.9	87.3	38.1	22.2	40.5		1.81
		MP-305	5305													
1 3/16 1 1/4	30	MP-19	3-13	5782	1 7/8	6 7/8	4 1/2	5 1/2	2 1/4	11/16	3 13/16	1 11/16	1	1 55/64	1/2	5.4
		MP-20	2-14	25718	47.6	174.6	114.3	139.7	57.2	17.5	96.8	42.9	25.4	47.2		2.45
		MP-306	5306													
1 7/16 1.378	35	MP-23	3-17	7340	2 1/8	8	5	6 3/8	2 1/4	3/4	4 3/16	1 15/16	1 3/16	2 1/16	1/2	6.8
		MP-307	5307	32648	54.0	203.2	127.0	161.9	57.2	19.1	106.4	49.2	30.2	52.4		3.08
1 1/2	40	MP-24	3-18	7901	2 5/16	8 3/4	5 1/2	6 3/4	2 5/8	13/16	4 9/16	1 15/16	1 3/16	2 19/64	5/8	9.0
		MP-308	5308	35144	58.7	222.3	139.7	171.5	66.7	20.6	115.9	49.2	30.2	58.3		4.08
1 11/16 1 3/4	45	MP-27	3-111	7889	2 5/16	8 3/4	5 7/16	6 13/16	2 5/8	13/16	4 5/8	2 1/32	1 9/32	2 15/32	5/8	9.5
		MP-28	3-112	35090	58.7	222.3	138.1	173.0	66.7	20.6	117.5	51.6	32.5	62.7		4.31
		MP-309	5309													
1 15/16 2	50	MP-31	3-115	9752	2 1/2	9 1/2	5 15/16	7 9/16	2 7/8	7/8	5 3/32	2 3/16	1 5/16	2 23/32	5/8	11.7
		MP-32	2-2	43377	63.5	241.3	150.8	192.1	73.0	22.2	129.4	55.6	33.3	69.1		5.31
		MP-310	5310													
2 3/16 2 1/4	55	MP-35	3-23	11789	2 3/4	10 1/4	6 9/16	7 15/16	3 1/8	1 1/16	5 5/8	2 9/16	1 9/16	2 63/64	3/4	16.2
		MP-36	2-24	52437	69.9	260.4	166.7	201.6	79.4	27.0	142.9	65.1	39.7	75.8		7.35
		MP-311	5311													
2 7/16 2 1/2	65	MP-39	3-27	13971	3	11 1/4	7 1/8	8 7/8	3 1/4	1 1/16	6 1/4	2 3/4	1 11/16	3 7/16	3/4	21.5
		MP-40	3-28	62143	76.2	285.8	181.0	225.4	82.6	27.0	158.8	69.9	42.9	87.3		9.75
		MP-313	5313													
2 11/16 2.756	70	MP-43	3-211	14839	3 1/2	13	7 7/8	10 1/8	3 1/2	1 1/8	7	3 1/16	1 3/4	3 41/64	7/8	29.2
		MP-314	5314	66004	88.9	330.2	200.0	257.2	88.9	28.6	177.8	77.8	44.5	92.5		13.24
2 15/16 3	75	MP-47	3-215	17412	3 1/2	13	7 7/8	10 1/8	3 1/2	1 1/4	7 1/4	3 1/4	1 15/16	3 59/64	7/8	31.5
		MP-48	3-3	77449	88.9	330.2	200.0	257.2	88.9	31.8	184.2	82.6	49.2	99.6		14.29
		MP-315	5315													
3 3/16 3 1/4	80	MP-51	3-33	18681	4	15	9 11/16	12 9/16	4	1 1/4	8	3 3/8	2 1/32	4 5/32	7/8	44.1
		MP-52	2-34	83093	101.6	381.0	246.1	319.1	101.6	31.8	203.2	85.7	51.6	105.6		20.00
		MP-316	5316													
3 7/16 3 1/2		MP-55	3-37	21566	4	15	9 5/8	12 5/8	4 3/8	1 5/16	8 1/4	3 25/32	2 7/32	4 25/64	7/8	47.8
		MP-56	2-38	95926	101.6	381.0	244.5	320.7	111.1	33.3	209.6	96.0	56.4	111.5		21.68
3 15/16 4	100	MP-63	3-315	29905	5	17	11 3/4	14 3/4	4 3/4	1 5/16	10	4 5/8	2 11/16	5 11/64	1	73.2
		MP-64	3-4	133017	127.0	431.8	298.5	374.7	120.7	33.3	254.0	117.5	68.3	131.4		33.20
		MP-320	5320													

For Medium Duty Bearing Inserts-Single Lock see page G-95.

Metric dimensions for reference only.

Not all parts are available from stock. Please contact customer service for availability (800) 626-2120.

For more information on bearing capabilities outside of our standard offering, please contact Application Engineering (800) 626-2093.

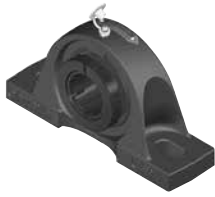

- Duty:** Medium
- Rolling Elements:** Ball
- Housing:** Cast Iron Pillow Block - High Base
- Self Alignment:** +/- 2 Degrees
- Lock:** SKWEZLOC Locking Collar
- Seal:** Felt
- Optional Seal:** Contact
- Temperature:** -20° to 220°F

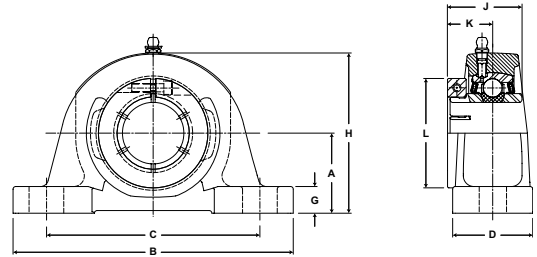

MP-T Series Medium Duty Pillow Blocks - SKWEZLOC Locking Collar

Bore Diameter inch	Part No.	Bearing Insert No.	Basic Dynamic Rating lb/N	Dimensions inch / mm										Bolt Size	Unit Wt. lb/kg
				A	B	C		D	G	H	J	K	L		
						min.	max.								
1	MP-16T	3-1T	4381 19487	1 3/4 44.5	6 1/4 158.8	4 3/16 106.4	5 3/16 131.8	2 50.8	5/8 15.9	3 7/16 87.3	1 9/16 39.7	15/16 23.8	2 1/16 52.4	1/2	4.2 1.91
1 3/16 1 1/4	MP-19T MP-20T	3-13T 2-14T	5782 25718	1 7/8 47.6	6 7/8 174.6	4 1/2 114.3	5 1/2 139.7	2 1/4 57.2	11/16 17.5	3 13/16 96.8	1 3/4 44.5	1 1/16 27.0	2 7/16 61.9	1/2	5.7 2.59
1 7/16	MP-23T	3-17T	7340 32648	2 1/8 54.0	8 203.2	5 127.0	6 3/8 161.9	2 1/4 57.2	3/4 19.1	4 3/16 106.4	2 50.8	1 1/4 31.8	2 11/16 68.3	1/2	7.1 3.22
1 1/2	MP-24T	3-18T	7901 35144	2 5/16 58.7	8 3/4 222.3	5 1/2 139.7	6 3/4 171.5	2 5/8 66.7	13/16 20.6	4 9/16 115.9	2 50.8	1 1/4 31.8	2 13/16 71.4	5/8	9.3 4.22
1 11/16 1 3/4	MP-27T MP-28T	3-111T 3-112T	7889 35090	2 5/16 58.7	8 3/4 222.3	5 7/16 138.1	6 13/16 173.0	2 5/8 66.7	13/16 20.6	4 5/8 117.5	2 3/32 53.2	1 11/32 34.1	3 1/4 82.6	5/8	10.1 4.58
1 15/16 2	MP-31T MP-32T	3-115T 2-2T	9752 43377	2 1/2 63.5	9 1/2 241.3	5 15/16 150.8	7 9/16 192.1	2 7/8 73.0	7/8 22.2	5 3/32 129.4	2 1/4 57.2	1 3/8 34.9	3 1/2 88.9	5/8	12.3 5.58
2 3/16 2 1/4	MP-35T MP-36T	3-23T 2-24T	11789 52437	2 3/4 69.9	10 1/4 260.4	6 9/16 166.7	7 15/16 201.6	3 1/8 79.4	1 1/16 27.0	5 5/8 142.9	2 5/8 66.7	1 5/8 41.3	4 1/16 103.2	3/4	17.4 7.89

For Medium Duty SKWEZLOC Locking Collar Bearing inserts see page G-96.

SEALMASTER® Performance Mounted Ball Bearings



Duty: Medium
Rolling Elements: Ball
Housing: Cast Iron Pillow Block - High Base
Self Alignment: +/- 2 Degrees
Lock: Double Setscrew
Seal: Felt
Optional Seal: Contact
Temperature: -20° to 220°F

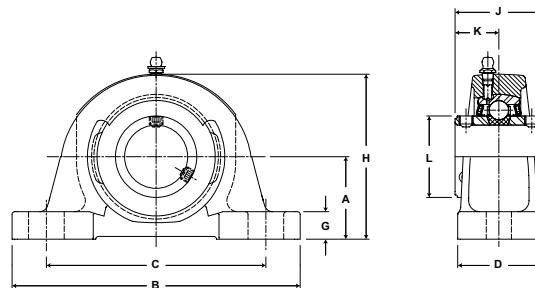

MPD Series Medium Duty Pillow Blocks With Double Lock - Setscrew Locking

Bore Diameter inch	Part No.	Bearing Insert No.	Basic Dynamic Rating lb/N	Dimensions inch / mm										Bolt Size	Unit Wt. lb/kg
				A	B	C		D	G	H	J	K	L		
						min.	max.								
1	MPD-16	3-1D	4381 19487	1 3/4 44.5	6 1/4 158.8	4 3/16 106.4	5 3/16 131.8	2 50.8	5/8 15.9	3 7/16 87.3	1 3/4 44.5	7/8 22.2	1 19/32 40.5	1/2	4.0 1.81
1 3/16	MPD-19	3-13D	5782	1 7/8	6 7/8	4 1/2	5 1/2	2 1/4	11/16	3 13/16	2	1	1 55/64	1/2	5.4
1 1/4	MPD-20	2-14D	25718	47.6	174.6	114.3	139.7	57.2	17.5	96.8	50.8	25.4	47.2	1/2	2.45
1 7/16	MPD-23	3-17D	7340 32648	2 1/8 54.0	8 203.2	5 127.0	6 3/8 161.9	2 1/4 57.2	3/4 19.1	4 3/16 106.4	2 5/16 58.7	1 5/32 29.4	2 1/16 52.4	1/2	6.8 3.08
1 1/2	MPD-24	3-18D	7901 35144	2 5/16 58.7	8 3/4 222.3	5 1/2 139.7	6 3/4 171.5	2 5/8 66.7	13/16 20.6	4 9/16 115.9	2 3/8 60.3	1 3/16 30.2	2 19/64 58.3	5/8	9.0 4.08
1 11/16	MPD-27	3-111D	7889	2 5/16	8 3/4	5 7/16	6 13/16	2 5/8	13/16	4 5/8	2 1/2	1 1/4	2 15/32	5/8	9.5
1 3/4	MPD-28	3-112D	35090	58.7	222.3	138.1	173.0	66.7	20.6	117.5	63.5	31.8	62.7	5/8	4.31
1 15/16	MPD-31	3-115D	9752	2 1/2	9 1/2	5 15/16	7 9/16	2 7/8	7/8	5 3/32	2 5/8	1 5/16	2 23/32	5/8	11.7
2	MPD-32	2-2D	43377	63.5	241.3	150.8	192.1	73.0	22.2	129.4	66.7	33.3	69.1	5/8	5.31
2 3/16	MPD-35	3-23D	11789	2 3/4	10 1/4	6 9/16	7 15/16	3 1/8	1 1/16	5 5/8	3 1/8	1 9/16	2 63/64	3/4	16.2
2 1/4	MPD-36	2-24D	52437	69.9	260.4	166.7	201.6	79.4	27.0	142.9	79.4	39.7	75.8	3/4	7.35
2 7/16	MPD-39	3-27D	13971	3	11 1/4	7 1/8	8 7/8	3 1/4	1 1/16	6 1/4	3 1/2	1 3/4	3 7/16	3/4	21.5
2 1/2	MPD-40	3-28D	62143	76.2	285.8	181.0	225.4	82.6	27.0	158.8	88.9	44.5	87.3	3/4	9.75
2 11/16	MPD-43	3-211D	14839 66004	3 1/2 88.9	13 330.2	7 7/8 200.0	10 1/8 257.2	3 1/2 88.9	1 1/8 28.6	7 177.8	3 1/2 88.9	1 3/4 44.5	3 41/64 92.5	7/8	29.2 13.24
2 15/16	MPD-47	3-215D	17412	3 1/2	13	7 7/8	10 1/8	3 1/2	1 1/4	7 1/4	3 7/8	1 15/16	3 59/64	7/8	31.5
3	MPD-48	3-3D	77449	88.9	330.2	200.0	257.2	88.9	31.8	184.2	98.4	49.2	99.6	7/8	14.29
3 3/16	MPD-51	3-33D	18681	4	15	9 11/16	12 9/16	4	1 1/4	8	4 1/16	2 1/32	4 5/32	7/8	44.1
3 1/4	MPD-52	2-34D	83093	101.6	381.0	246.1	319.1	101.6	31.8	203.2	103.2	51.6	105.6	7/8	20.00
3 7/16	MPD-55	3-37D	21566	4	15	9 5/8	12 5/8	4 3/8	1 5/16	8 1/4	4 7/16	2 7/32	4 25/64	7/8	47.8
3 1/2	MPD-56	2-38D	95926	101.6	381.0	244.5	320.7	111.1	33.3	209.6	112.7	56.4	111.5	7/8	21.68
3 15/16	MPD-63	3-315D	29905	5	17	11 3/4	14 3/4	4 3/4	1 5/16	10	5 3/8	2 11/16	5 11/64	1	73.2
4	MPD-64	3-4D	133017	127.0	431.8	298.5	374.7	120.7	33.3	254.0	136.5	68.3	131.4	1	33.20

For Medium Duty Bearing Inserts-Double Lock see page G-97.

Metric dimensions for reference only.

Not all parts are available from stock. Please contact customer service for availability (800) 626-2120.

For more information on bearing capabilities outside of our standard offering, please contact Application Engineering (800) 626-2093.



- Duty:** Medium
- Rolling Elements:** Ball
- Housing:** Cast Iron Four Bolt Pillow Block - High Base
- Self Alignment:** +/- 2 Degrees
- Lock:** Setscrew
- Seal:** Felt
- Optional Seal:** Contact
- Temperature:** -20° to 220°F
- Relube:** Relube

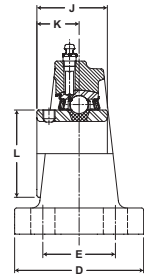
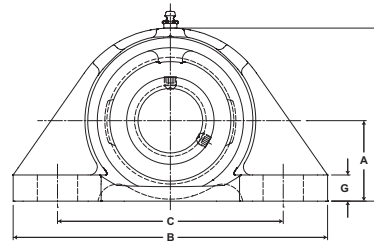

MFP Series Medium Duty Four-Bolt Base Pillow Blocks - Setscrew Locking

Bore Diameter		Part No.	Bearing Insert No.	Basic Dynamic Rating lb/N	Dimensions inch / mm										Bolt Size	Unit Wt. lb/kg	
					A	B	C		D	E	G	H	J	K			L
inch	mm						min.	max.									
1 15/16 2	50	MFP-31	3-115	9752 43377	2 1/2 63.5	9 3/4 247.7	6 3/8 161.9	7 5/8 193.7	4 101.6	2 1/4 57.2	13/16 20.6	5 3/8 136.5	2 3/16 55.6	1 5/16 33.3	2 23/32 69.1	5/8	13.7 6.21
		MFP-32	2-2														
		MFP-310	5310														
2 3/16 2 1/4	55	MFP-35	3-23	11789 52437	2 3/4 69.9	10 1/4 260.4	6 7/8 174.6	8 1/8 206.4	4 1/8 104.8	2 1/4 57.2	7/8 22.2	5 13/16 147.6	2 9/16 65.1	1 9/16 39.7	2 63/64 75.8	5/8	17.0 7.71
		MFP-36	2-24														
		MFP-311	5311														
2 7/16 2 1/2	65	MFP-39	3-27	13971 62143	3 76.2	11 1/4 285.8	7 1/2 190.5	9 228.6	4 1/2 114.3	2 5/8 66.7	1 25.4	6 1/2 165.1	2 3/4 69.9	1 11/16 42.9	3 7/16 87.3	5/8	23.3 10.57
		MFP-40	3-28														
		MFP-313	5313														
2 11/16	70	MFP-43	3-211	14839 66004	3 1/2 88.9	13 330.2	9 228.6	10 1/2 266.7	5 127.0	2 3/4 69.9	1 1/8 28.6	7 1/4 184.2	3 1/16 77.8	1 3/4 44.5	3 41/64 92.5	3/4	34.0 15.42
		MFP-314	5314														
2 15/16 3	75	MFP-47	3-215	17412 77449	3 1/2 88.9	13 330.2	9 228.6	10 1/2 266.7	5 127.0	2 3/4 69.9	1 25.4	7 3/8 187.3	3 1/4 82.6	1 15/16 49.2	3 59/64 99.6	3/4	36.5 16.56
		MFP-48	3-3														
		MFP-315	5315														
3 3/16 3 1/4	80	MFP-51	3-33	18681 83093	4 101.6	15 381.0	10 3/4 273.1	12 1/4 311.2	5 127.0	3 76.2	1 1/16 27.0	8 7/16 214.3	3 3/8 85.7	2 1/32 51.6	4 5/32 105.6	3/4	44.5 20.18
		MFP-52	2-34														
		MFP-316	5316														
3 7/16 3 1/2		MFP-55	3-37	21566 95926	4 101.6	15 381.0	10 3/4 273.1	12 1/4 311.2	5 127.0	3 76.2	1 1/16 27.0	8 7/16 214.3	3 25/32 96.0	2 7/32 56.4	4 25/64 111.5	3/4	48.6 22.04
		MFP-56	2-38														
3 15/16 4	100	MFP-63	3-315	29905 133017	5 127.0	17 431.8	12 7/16 315.9	14 1/16 357.2	6 152.4	3 1/2 88.9	1 1/4 31.8	10 1/4 260.4	4 5/8 117.5	2 11/16 68.3	5 11/64 131.4	7/8	83.5 37.87
		MFP-64	3-4														
		MFP-320	5320														

For Medium Duty Bearing Inserts-Single Lock see page G-95.



Duty: Medium
Rolling Elements: Ball
Housing: Cast Iron Four Bolt Pillow Block - High Base
Self Alignment: +/- 2 Degrees
Lock: Double Setscrew
Seal: Felt
Optional Seal: Contact
Temperature: -20° to 220°F

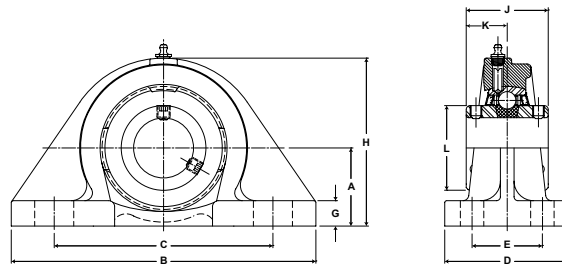

MFPD Series Medium Duty Four-Bolt Base Pillow Blocks With Double Lock - Setscrew Locking

Bore Diameter inch	Part No.	Bearing Insert No.	Basic Dynamic Rating lb/N	Dimensions inch / mm											Bolt Size	Unit Wt. lb/kg
				A	B	C		D	E	G	H	J	K	L		
						min.	max.									
1 15/16	MFPD-31	3-115D	9752 43377	2 1/2 63.5	9 3/4 247.7	6 3/8 161.9	7 5/8 193.7	4 101.6	2 1/4 57.2	13/16 20.6	5 3/8 136.5	2 5/8 66.7	1 5/16 33.3	2 23/32 69.1	5/8	13.7 6.21
2 3/16	MFPD-35	3-23D	11789 52437	2 3/4 69.9	10 1/4 260.4	6 7/8 174.6	8 1/8 206.4	4 1/8 104.8	2 1/4 57.2	7/8 22.2	5 13/16 147.6	3 1/8 79.4	1 9/16 39.7	2 63/64 75.8	5/8	17 7.71
2 7/16	MFPD-39	3-27D	13971	3 76.2	11 1/4 285.8	7 1/2 190.5	9 228.6	4 1/2 114.3	2 5/8 66.7	1 25.4	6 1/2 165.1	3 1/2 88.9	1 3/4 44.5	3 7/16 87.3	5/8	23.3 10.57
2 1/2	MFPD-40	3-28D	62143													
2 11/16	MFPD-43	3-211D	14839 66004	3 1/2 88.9	13 330.2	9 228.6	10 1/2 266.7	5 127.0	2 3/4 69.9	1 1/8 28.6	7 1/4 184.2	3 1/2 88.9	1 3/4 44.5	3 41/64 92.5	3/4	34 863.6
2 15/16	MFPD-47	3-215D	17412	3 1/2 88.9	13 330.2	9 228.6	10 1/2 266.7	5 127.0	2 3/4 69.9	1 25.4	7 3/8 187.3	3 7/8 98.4	1 15/16 49.2	3 59/64 99.6	3/4	36.5 16.56
3	MFPD-48	3-3D	77449													
3 7/16	MFPD-55	3-37D	21566	4 101.6	15 381.0	25 3/4 654.1	12 1/4 311.2	5 127.0	3 76.2	1 1/16 27.0	8 7/16 214.3	4 39/89 112.7	2 7/32 56.4	4 25/64 111.5	3/4	48.6 22.04
3 1/2	MFPD-56	2-38D	95926													
3 15/16	MFPD-63	3-315D	29905	5 127.0	17 431.8	12 7/16 315.9	14 1/16 357.2	6 152.4	3 1/2 88.9	1 1/4 31.8	10 1/4 260.4	5 3/8 136.5	2 11/16 68.3	5 11/64 131.4	7/8	83.5 37.87
4	MFPD-64	3-4D	133017													
4 7/16	MFPD-71*	3-47D	37482	6 152.4	19 482.6	14 355.6	16 406.4	5 1/2 139.7	3 1/4 82.6	1 5/8 41.3	12 1/8 308.0	5 3/4 146.1	2 7/8 73.0	6 11/32 161.1	1	130.0 58.97
4 15/16	MFPD-79*	3-415D	166720													
5	MFPD-80	3-500D														

* Units MFPD-71, MFPD-79 and MFPD-80 are not available with contact seal.
 For Medium Duty Bearing Inserts-Double Lock see page G-97.

Metric dimensions for reference only.

Not all parts are available from stock. Please contact customer service for availability (800) 626-2120.

For more information on bearing capabilities outside of our standard offering, please contact Application Engineering (800) 626-2093.



- Duty:** Medium
- Rolling Elements:** Ball
- Housing:** Cast Iron Pillow Block – Heavy Duty
- Self Alignment:** +/- 2 Degrees
- Lock:** Double Setscrew
- Seal:** Felt
- Optional Seal:** Contact
- Temperature:** -20° to 220°F

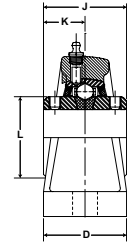
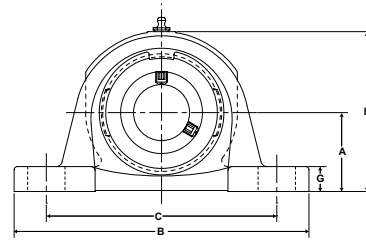

MSPD Series Medium Duty Pillow Blocks With Double Lock - Setscrew Locking

Bore Diameter inch	Part No.	Bearing Insert No.	Basic Dynamic Rating lb/N	Dimensions inch / mm										Bolt Size	Unit Wt. lb/kg
				A	B	C		D	G	H	J	K	L		
						min.	max.								
1 11/16	MSPD-27	3-111D	7889	2 3/8	8 7/8	6 7/16	7 7/16	2 1/2	3/4	4 13/16	2 1/2	1 1/4	2 1/2	5/8	9.5
1 3/4	MSPD-28	3-112D	35090	60.3	225.4	163.5	188.9	63.5	19.1	122.2	63.5	31.8	63.5	5/8	4.31
1 15/16	MSPD-31	3-115D	9752	2 3/4	10	7 1/8	8 3/8	2 5/8	7/8	5 7/16	2 5/8	1 5/16	2 5/8	5/8	12.5
2	MSPD-32	2-2D	43377	69.9	254.0	181.0	212.7	66.7	22.2	138.1	66.7	33.3	66.7	5/8	5.67
2 3/16	MSPD-35	3-23D	11789	3 1/8	10 7/8	7 7/8	9 3/8	2 3/4	15/16	6 1/16	3 1/8	1 9/16	2 63/64	5/8	17.0
2 1/4	MSPD-36	2-24D	52437	79.4	276.2	200.0	238.1	69.9	23.8	154.0	79.4	39.7	75.8	5/8	7.71
2 7/16	MSPD-39	3-27D	13971	3 1/8	11 3/4	8 3/4	9 7/8	3	1	6 5/16	3 1/2	1 3/4	3 1/2	3/4	22.0
2 1/2	MSPD-40	3-28D	62143	79.4	298.5	222.3	250.8	76.2	25.4	160.3	88.9	44.5	88.9	3/4	9.98
2 11/16	MSPD-43	3-211D	14839	3 3/4	13 3/8	10 1/8	11 3/8	3 1/4	1	7 5/16	3 1/2	1 3/4	3 1/2	3/4	28.0
			66004	95.3	339.7	257.2	288.9	82.6	25.4	185.7	88.9	44.5	88.9	3/4	12.70
2 15/16	MSPD-47	3-215D	17412	3 3/4	13 3/4	10	11 1/2	3 3/8	1 3/16	7 1/2	3 7/8	1 15/16	3 7/8	7/8	33.0
3	MSPD-48	3-3D	77449	95.3	349.3	254.0	292.1	85.7	30.2	190.5	98.4	49.2	98.4	7/8	14.97
3 7/16	MSPD-55	3-37D	21566	4 9/16	15 3/8	12 1/8	13 1/2	4	1 1/4	8 13/16	4 7/16	2 7/32	4 7/16	7/8	51.0
3 1/2	MSPD-56	2-38D	95926	115.9	390.5	308.0	342.9	101.6	31.8	223.8	112.7	56.4	112.7	7/8	23.13
3 15/16	MSPD-63	3-315D	29905	5 1/8	17	13 1/8	14 3/4	4 3/4	1 1/4	10 1/8	5 3/8	2 11/16	5 3/8	1	74.5
4	MSPD-64	3-4D	133017	130.2	431.8	333.4	374.7	120.7	31.8	257.2	136.5	68.3	136.5	1	33.79
4 7/16	MSPD-71	3-47D *	37482	6 1/4	21 1/4	15 1/16	18 3/16	6 1/4	1 3/4	12 1/2	5 3/4	2 7/8	5 3/4	1 1/8	159.0
4 15/16	MSPD-79	3-415D *	166720	158.8	539.8	382.6	462.0	158.8	44.5	317.5	146.1	73.0	146.1	1 1/8	72.12

* Units MSPD-71 and MSPD-79 are not available with contact seal.
For Medium Duty Bearing Inserts-Double Lock see page G-97.



Duty: Medium
Rolling Elements: Ball
Housing: Cast Iron Four Bolt Pillow Block – Heavy Duty
Self Alignment: +/- 2 Degrees
Lock: Double Setscrew
Seal: Felt
Optional Seal: Contact
Temperature: -20° to 220°F

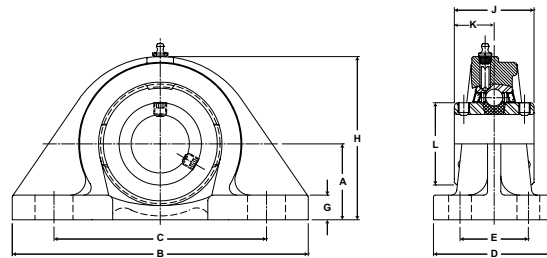

MSFPD Series Medium Duty Four-Bolt Base Pillow Blocks With Double Lock - Setscrew Locking

Bore Diameter inch	Part No.	Bearing Insert No.	Basic Dynamic Rating lb/N	Dimensions inch / mm											Bolt Size	Unit Wt. lb/kg
				A	B	C		D	E	G	H	J	K	L		
						min.	max.									
1 15/16 2	MSFPD-31 MSFPD-32	3-115D 2-2D	9752 43377	2 3/4 69.9	9 3/4 247.7	6 3/8 161.9	7 5/8 193.7	4 101.6	2 1/4 57.2	1 1/16 27.0	5 5/8 142.9	2 5/8 66.7	1 5/16 33.3	2 5/8 66.7	5/8	15.4 6.99
2 3/16 2 1/4	MSFPD-35 MSFPD-36	3-23D 2-24D	11789 52437	3 1/8 79.4	10 1/4 260.4	6 7/8 174.6	8 1/8 206.4	4 1/8 104.8	2 1/4 57.2	1 1/4 31.8	6 3/16 157.2	3 1/8 79.4	1 9/16 39.7	2 63/64 75.8	5/8	20.1 9.12
2 7/16 2 1/2	MSFPD-39 MSFPD-40	3-27D 3-28D	13971 62143	3 1/8 79.4	11 5/16 287.3	7 1/2 190.5	9 228.6	4 1/2 114.3	2 5/8 66.7	1 1/8 28.6	6 5/8 168.3	3 1/2 88.9	1 3/4 44.5	3 1/2 88.9	5/8	25.4 11.52
2 11/16	MSFPD-43	3-211D	14839 66004	3 3/4 95.3	13 330.2	9 228.6	10 1/2 266.7	5 127.0	2 3/4 69.9	1 3/8 34.9	7 1/2 190.5	3 1/2 88.9	1 3/4 44.5	3 1/2 88.9	3/4	37.3 16.92
2 15/16 3	MSFPD-47 MSFPD-48	3-215D 3-3D	17412 77449	3 3/4 95.3	13 330.2	9 228.6	10 1/2 266.7	5 127.0	2 3/4 69.9	1 1/4 31.8	7 5/8 193.7	3 7/8 98.4	1 15/16 49.2	3 7/8 98.4	3/4	40.1 18.19
3 3/16 3 1/4	MSFPD-51 MSFPD-52	3-33D 2-34D	18681 83093	4 1/8 104.8	15 381.0	10 3/4 273.1	12 1/4 311.2	5 127.0	3 76.2	1 3/16 30.2	8 9/16 217.5	4 1/16 103.2	2 1/32 51.6	4 5/32 105.6	3/4	51.2 23.22
3 7/16 3 1/2	MSFPD-55 MSFPD-56	3-37D 2-38D	21566 95926	4 9/16 115.9	15 381.0	10 3/4 273.1	12 1/4 311.2	5 127.0	3 76.2	1 1/4 31.8	9 228.6	4 7/16 112.7	2 7/32 56.4	4 7/16 112.7	3/4	51.8 23.50
3 15/16 4	MSFPD-63 MSFPD-64	3-315D 3-4D	29905 133017	5 1/8 130.2	17 431.8	12 7/16 315.9	14 1/16 357.2	6 152.4	3 1/2 88.9	1 3/8 34.9	10 3/8 263.5	5 3/8 136.5	2 11/16 68.3	5 3/8 136.5	7/8	84.6 38.37
4 7/16 4 15/16	MSFPD-71 MSFPD-79	3-47D 3-415D	37482 166720	6 1/4 158.8	19 482.6	14 355.6	16 406.4	5 1/2 139.7	3 1/4 82.6	1 7/8 47.6	12 3/8 314.3	5 3/4 146.1	2 7/8 73.0	5 3/4 146.1	1	136.0 61.69

For Medium Duty Bearing Inserts-Double Lock see page G-97.
 Units MSFPD-71 and MSFPD-79 are not available with contact seal.

Metric dimensions for reference only.

Not all parts are available from stock. Please contact customer service for availability (800) 626-2120.

For more information on bearing capabilities outside of our standard offering, please contact Application Engineering (800) 626-2093.

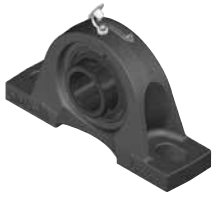

- Duty:** Medium
- Rolling Elements:** Ball
- Housing:** Cast Iron Pillow Block - Heavy Duty
- Self Alignment:** +/- 2 Degrees
- Lock:** Setscrew
- Seal:** Felt
- Optional Seal:** Contact
- Temperature:** -20° to 220°F

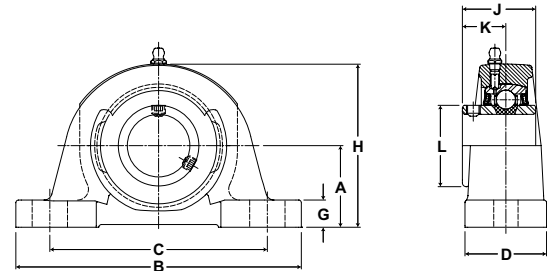

SPM Series Medium Duty Pillow Blocks - Setscrew Locking

Bore Diameter inch	Part No.	Bearing Insert No.	Basic Dynamic Rating lb/N	Dimensions inch / mm										Bolt Size	Unit Wt. lb/kg
				A	B	C		D	G	H	J	K	L		
						min.	max.								
1 3/16	SPM-19	3-13	5782 25718	2 50.8	7 1/2 190.5	5 3/8 136.5	6 1/8 155.6	2 50.8	5/8 15.9	3 7/8 98.4	1 11/16 42.9	1 25.4	1 55/64 47.2	1/2	6.9 3.13
1 7/16	SPM-23	3-17	7340 32648	2 3/8 60.3	8 1/4 209.6	5 5/8 142.9	6 7/8 174.6	2 1/4 57.2	3/4 19.1	4 1/2 114.3	1 15/16 49.2	1 3/16 30.2	2 1/16 52.4	5/8	7.1 3.22
1 11/16	SPM-27	3-111	7889	2 3/8	8 3/4	5 7/8	7 1/8	2 3/8	3/4	4 5/8	2 1/32	1 9/32	2 15/32	5/8	9.7 4.40
1 3/4	SPM-28	3-112	35090	60.3	222.3	149.2	181.0	60.3	19.1	117.5	51.6	32.5	62.7		
1 15/16	SPM-31	3-115	9752 43377	2 3/4 69.9	10 1/2 266.7	6 3/4 171.5	8 1/2 215.9	2 1/2 63.5	7/8 22.2	5 5/16 134.9	2 3/16 55.6	1 5/16 33.3	2 23/32 69.1	5/8	11.9 5.40
2 3/16	SPM-35	3-23	11789 52437	3 1/8 79.4	11 1/4 285.8	7 5/8 193.7	9 3/8 238.1	2 3/4 69.9	7/8 22.2	5 15/16 150.8	2 9/16 65.1	1 9/16 39.7	2 63/64 75.8	5/8	16.6 7.53
2 7/16	SPM-39	3-27	13971	3 1/8	11 1/2	7 7/8	9 3/8	3	7/8	6 1/4	2 3/4	1 11/16	3 7/16	3/4	20.1 9.12
2 1/2	SPM-40	3-28	62143	79.4	292.1	200.0	238.1	76.2	22.2	158.8	69.9	42.9	87.3		

For Medium Duty Bearing Inserts-Single Lock see page G-95.



- Duty:** Standard
- Rolling Elements:** Ball
- Housing:** Cast Iron Tapped Base Pillow Block
- Self Alignment:** +/- 2 Degrees
- Lock:** Setscrew
- Seal:** Felt
- Optional Seal:** Contact
- Temperature:** -20° to 220°F

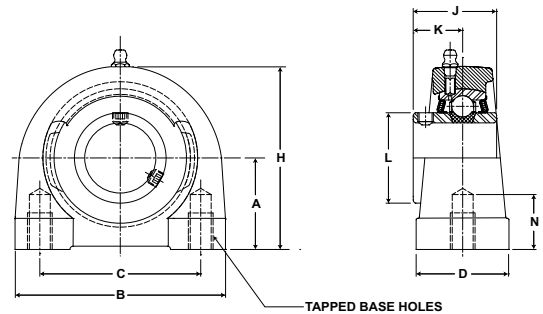

TB Series Tapped Base Pillow Blocks - Setscrew Locking

Bore Diameter		Part No.	Bearing Insert No.	Basic Dynamic Rating lb/N	Dimensions inch / mm								Bolt UNC-2B Thread	Unit Wt. lb/kg	
inch	mm				A	B	C	D	H	J	K	L			N Tap Depth
1/2	20	TB-8	2-08	2611 11614	1 5/16 33.3	3 1/8 79.4	2 50.8	1 1/2 38.1	2 9/16 65.1	1 7/32 31.0	23/32 18.3	1 3/16 30.2	1/2 12.7	3/8-16	1.8 .82
9/16		TB-9	2-09												
5/8		TB-10	2-010												
11/16		TB-11	2-011												
3/4		TB-12	2-012												
		TB-204	5204												
7/8	25	TB-14	2-014	2801 12459	1 7/16 36.5	3 76.2	2 50.8	1 1/2 38.1	2 13/16 71.4	1 3/8 34.9	13/16 20.6	1 3/8 34.9	1/2 12.7	3/8-16	2.0 .91
15/16		TB-15	2-015												
1		TB-16	2-1												
		TB-205	5205												
1 1/16	30	TB-17	2-11	4381 19487	1 11/16 42.9	4 101.6	3 76.2	1 1/2 38.1	3 13/32 86.5	1 1/2 38.1	7/8 22.2	1 19/32 40.5	5/8 15.9	7/16-14	3.5 1.59
1 1/8		TB-18	2-12												
1 3/16		TB-19	2-13												
1 1/4		TB-20R	1-14												
		TB-206	5206												
1 1/4	35	TB-20	2-14	5782 25718	1 7/8 47.6	4 1/4 108.0	3 1/4 82.6	1 7/8 47.6	3 3/4 95.3	1 11/16 42.9	1 25.4	1 55/64 47.2	3/4 19.1	1/2-13	4.5 2.04
1 5/16		TB-21	2-15												
1 3/8		TB-22	2-16												
1 7/16		TB-23	2-17												
		TB-207	5207												
1 1/2	40	TB-24	2-18	7340 32648	1 15/16 49.2	4 5/8 117.5	3 1/2 88.9	1 7/8 47.6	3 15/16 100.0	1 15/16 49.2	1 3/16 30.2	2 1/16 52.4	3/4 19.1	1/2-13	6.0 2.72
1 9/16		TB-25	2-19												
		TB-208	5208												
1 5/8	45	TB-26	2-110	7901 35144	2 1/8 54.0	5 127.0	3 3/4 95.3	2 50.8	4 1/4 108.0	1 15/16 49.2	1 3/16 30.2	2 19/64 58.3	3/4 19.1	1/2-13	6.5 2.95
1 11/16		TB-27	2-111												
1 3/4		TB-28	2-112												
		TB-209	5209												
1 7/8	50	TB-30	2-114	7889 35090	2 1/4 57.2	5 1/2 139.7	4 101.6	2 50.8	4 5/8 117.5	2 1/32 51.6	1 9/32 32.5	2 15/32 62.7	7/8 22.2	5/8-11	8.0 3.63
1 15/16		TB-31	2-115												
2		TB-32R	1-2												
		TB-210	5210												

For Standard Duty Bearing Inserts-Single Lock see page G-92.

Metric dimensions for reference only.

Not all parts are available from stock. Please contact customer service for availability (800) 626-2120.

For more information on bearing capabilities outside of our standard offering, please contact Application Engineering (800) 626-2093.



- Duty:** Standard
- Rolling Elements:** Ball
- Housing:** Cast Iron Tapped Base Pillow Block
- Self Alignment:** +/- 2 Degrees
- Lock:** SKWEZLOC Locking Collar
- Seal:** Felt
- Optional Seal:** Contact
- Temperature:** -20° to 220°F

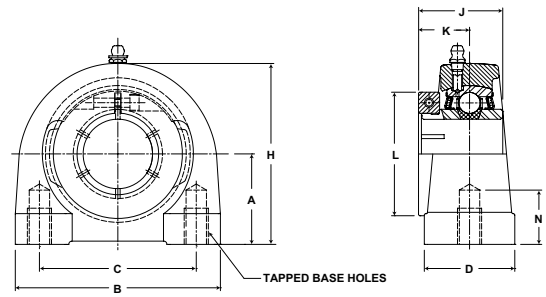

TB-T Series Standard Duty Tapped Base Pillow Block - SKWEZLOC Locking Collar - Inch

Bore Diameter inch	Part No.	Bearing Insert No.	Basic Dynamic Rating lb/N	Dimensions inch / mm									Bolt UNC-2B Thread	Unit Wt. lb/kg
				A	B	C	D	H	J	K	L	N Tap Depth		
3/4	*TB-12T	2-012T	2611	1 5/16	3 1/8	2	1 1/2	2 9/16	1 9/32	25/32	1 3/4	1/2	3/8-16	1.8
			11614	33.3	79.4	50.8	38.1	65.1	32.5	19.8	44.5	12.7		
15/16	TB-15T	2-015T	2801	1 7/16	3	2	1 1/2	2 13/16	1 7/16	7/8	1 15/16	1/2	3/8-16	2.0
			12459	36.5	76.2	50.8	38.1	71.4	36.5	22.2	49.2	12.7		
1 1/8	TB-18T	2-12T	4381	1 11/16	4	3	1 1/2	3 13/32	1 9/16	15/16	2 3/16	5/8	7/16-14	3.7
			19487	42.9	101.6	76.2	38.1	86.5	39.7	23.8	55.6	15.9		
1 3/16	TB-19T	2-13T	19487	42.9	101.6	76.2	38.1	86.5	39.7	23.8	55.6	15.9	7/16-14	1.68
1 1/4	TB-20T	2-14T	5782	1 7/8	4 1/4	3 1/4	1 7/8	3 3/4	1 3/4	1 1/16	2 7/16	3/4	1/2-13	4.8
			25718	47.6	108.0	82.6	47.6	95.3	44.5	27.0	61.9	19.1		
1 3/8	TB-22T	2-16T	5782	1 7/8	4 1/4	3 1/4	1 7/8	3 3/4	1 3/4	1 1/16	2 9/16	3/4	1/2-13	4.8
			25718	47.6	108.0	82.6	47.6	95.3	44.5	27.0	65.1	19.1		
1 7/16	TB-23T	2-17T	25718	47.6	108.0	82.6	47.6	95.3	44.5	27.0	65.1	19.1	1/2-13	2.18
1 1/2	TB-24T	2-18T	7340	1 15/16	4 5/8	3 1/2	1 7/8	3 15/16	2	1 1/4	2 11/16	3/4	1/2-13	6.3
			32648	49.2	117.5	88.9	47.6	100.0	50.8	31.8	68.3	19.1		
1 5/8	TB-26T	2-110T	7901	2 1/8	5	3 3/4	2	4 1/4	2	1 1/4	2 13/16	3/4	1/2-13	6.8
			35144	54.0	127.0	95.3	50.8	108.0	50.8	31.8	71.4	19.1		
1 11/16	TB-27T	2-111T	7901	2 1/8	5	3 3/4	2	4 1/4	2	1 1/4	2 15/16	3/4	1/2-13	6.8
			35144	54.0	127.0	95.3	50.8	108.0	50.8	31.8	74.6	19.1		
1 3/4	TB-28T	2-112T	35144	54.0	127.0	95.3	50.8	108.0	50.8	31.8	74.6	19.1	1/2-13	3.08
1 15/16	TB-31T	2-115T	7889	2 1/4	5 1/2	4	2	4 5/8	2 3/32	1 11/32	3 3/8	7/8	5/8-11	8.6
			35090	57.2	139.7	101.6	50.8	117.5	53.2	34.1	85.7	22.2		
2	TB-32RT	1-2T	35090	57.2	139.7	101.6	50.8	117.5	53.2	34.1	85.7	22.2	5/8-11	3.90

* Bearing reversed in housing for collar clearance

TB-T Series Standard Duty Tapped Base Pillow Block - SKWEZLOC Locking Collar - Metric -SKWEZ™

Bore Diameter mm	Part No.	Bearing Insert No.	Basic Dynamic Rating N/lb	Dimensions mm / inch									M Bolt Thread mm	Unit Wt. kg/lb
				A	B	C	D	H	J	K	L	N Min. Tap Depth		
20	*TB-204TMC	5204TMC	11614	33.3	79.4	52.0	38.1	65.1	32.5	19.8	44.5	11	M10 x 1.5	.82
			2611	1 5/16	3 1/8	2 3/64	1 1/2	2 9/16	1 9/32	25/32	1 3/4	7/16		
25	TB-205TMC	5205TMC	12459	36.5	76.2	56.0	38.1	71.4	36.5	22.2	49.2	11	M10 x 1.5	.91
			2801	1 7/16	3	2 13/64	1 1/2	2 13/16	1 7/16	7/8	1 15/16	7/16		
30	TB-206TMC	5206TMC	19487	42.9	101.6	65.9	38.1	86.5	39.7	23.8	55.6	16	M14 x 2.0	1.68
			4381	1 11/16	4	2 19/32	1 1/2	3 13/32	1 9/16	15/16	2 3/16	5/8		
35	TB-207TMC	5207TMC	25718	47.6	108.0	80.2	47.6	95.3	44.5	27.0	65.1	17.5	M14 x 2.0	2.18
			5782	1 7/8	4 1/4	3 5/32	1 7/8	3 3/4	1 3/4	1 1/16	2 9/16	11/16		
40	TB-208TMC	5208TMC	32648	49.2	117.5	84.1	47.6	100.0	50.8	31.8	68.3	17.5	M14 x 2.0	2.86
			7340	1 15/16	4 5/8	3 5/16	1 7/8	3 15/16	2	1 1/4	2 11/16	11/16		
45	TB-209TMC	5209TMC	35144	54.0	127.0	90.1	50.8	108.0	50.8	31.8	74.6	22	M14 x 2.0	3.08
			7901	2 1/8	5	3 35/64	2	4 1/4	2	1 1/4	2 15/16	7/8		
50	TB-210TMC	5210TMC	35090	57.2	139.7	94.1	50.8	117.5	53.2	34.1	85.7	22	M16 x 2.0	3.90
			7889	2 1/4	5 1/2	3 45/64	2	4 5/8	2 3/32	1 11/32	3 3/8	7/8		

* Bearing reversed in housing for collar clearance

For Standard Duty SKWEZLOC Single Locking Collar Bearing Inserts see page G-93.

SEALMASTER® Performance Mounted Ball Bearings



- Duty:** Standard
- Rolling Elements:** Ball
- Housing:** Cast Iron Four Bolt Flange
- Self Alignment:** +/- 2 Degrees
- Lock:** Setscrew
- Seal:** Felt
- Optional Seal:** Contact
- Temperature:** -20° to 220°F

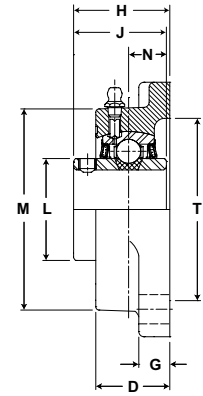
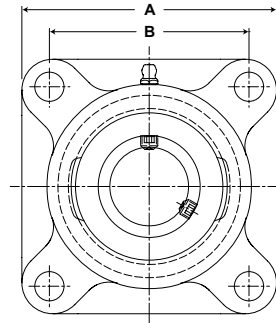

SF Series Standard Duty Four-Bolt Flange Units - Setscrew Locking

Bore Diameter		Part No.	Bearing Insert No.	Basic Dynamic Rating lb/N	Dimensions inch / mm										Bolt Size	Unit Wt. lb/kg	
inch	mm				A	B*	D	G	H	J	N	L	M	T Core			
1/2		SF-8	2-08														
9/16		SF-9	2-09	2611	3	2 1/8	59/64	7/16	1 9/32	1 7/32	1/2	1 3/16	2 17/64	2	3/8	1.4	
5/8		SF-10	2-010	11614	76.2	54.0	23.4	11.1	32.5	31.0	12.7	30.2	57.5	50.8	3/8	.64	
11/16		SF-11	2-011														
3/4	20	SF-12	2-012	2611	3 3/8	2 1/2	59/64	7/16	1 9/32	1 7/32	1/2	1 3/16	2 11/32	2	3/8	1.5	
		SF-204	5204	11614	85.7	63.5	23.4	11.1	32.5	31.0	12.7	30.2	59.5	50.8	3/8	.68	
13/16		SF-13	2-013														
7/8		SF-14	2-014	2801	3 3/4	2 3/4	1 1/32	17/32	1 7/16	1 3/8	9/16	1 3/8	2 23/32	2 3/8	7/16	2.1	
15/16		SF-15	2-015	12459	95.3	69.9	26.2	13.5	36.5	34.9	14.3	34.9	69.1	60.3	7/16	.95	
1	25	SF-16	2-1														
		SF-205	5205														
1 1/16		SF-17	2-11														
1 1/8		SF-18	2-12	4381	4 1/4	3 1/4	1 11/64	17/32	1 9/16	1 1/2	5/8	1 19/32	3 7/32	2 7/8	7/16	3.6	
1 3/16		SF-19	2-13	19487	108.0	82.6	29.8	13.5	39.7	38.1	15.9	40.5	81.8	73.0	7/16	1.63	
1 1/4	30	SF-20R	1-14														
		SF-206	5206														
1 1/4		SF-20	2-14														
1 5/16		SF-21	2-15	5782	4 5/8	3 5/8	1 11/32	9/16	1 3/4	1 11/16	11/16	1 55/64	3 23/32	3 5/16	1/2	4.1	
1 3/8		SF-22	2-16	25718	117.5	92.1	34.1	14.3	44.5	42.9	17.5	47.2	94.5	84.1	1/2	1.86	
1 7/16	35	SF-23	2-17														
		SF-207	5207														
1 1/2		SF-24	2-18														
1 9/16	40	SF-25	2-19	7340	5 1/8	4	1 1/2	9/16	2 1/64	1 15/16	3/4	2 1/16	4 5/64	3 1/2	1/2	5.5	
		SF-208	5208	32648	130.2	101.6	38.1	14.3	51.2	49.2	19.1	52.4	103.6	88.9	1/2	2.49	
1 5/8		SF-26	2-110														
1 11/16		SF-27	2-111	7901	5 3/8	4 1/8	1 9/16	9/16	2 3/64	1 15/16	3/4	2 19/64	4 21/64	3 7/8	9/16	5.7	
1 3/4	45	SF-28	2-112	35144	136.5	104.8	39.7	14.3	52.0	49.2	19.1	58.3	109.9	98.4	9/16	2.59	
		SF-209	5209														
1 13/16		SF-29	2-113														
1 7/8		SF-30	2-114	7889	5 5/8	4 3/8	1 9/16	9/16	2 5/32	2 1/32	3/4	2 15/32	4 33/64	4	9/16	6.4	
1 15/16		SF-31	2-115	35090	142.9	111.1	39.7	14.3	54.8	51.6	19.1	62.7	114.7	101.6	9/16	2.90	
2	50	SF-32R	1-2														
		SF-210	5210														
2		SF-32	2-2														
2 1/8		SF-34	2-22	9752	6 3/8	5 1/8	1 3/4	13/16	2 5/16	2 3/16	7/8	2 23/32	5 3/16	4 1/4	5/8	10.5	
2 3/16	55	SF-35	2-23	43377	161.9	130.2	44.5	20.6	58.7	55.6	22.2	69.1	131.8	108.0	5/8	4.76	
		SF-211	5211														
2 1/4		SF-36	2-24														
2 3/8		SF-38	2-26	11789	6 7/8	5 5/8	1 15/16	13/16	2 11/16	2 9/16	1	2 63/64	5 7/16	5	5/8	11.8	
2 7/16	60	SF-39	2-27	52437	174.6	142.9	49.2	20.6	68.3	65.1	25.4	75.8	138.1	127.0	5/8	5.35	
		SF-212	5212														
2 1/2		SF-40	3-28														
2 11/16	70	SF-43	2-211	13971	7 3/8	5 7/8	2 5/16	11/16	3	2 3/4	1 1/16	3 7/16	6 1/8	5 1/8	5/8	16.4	
		SF-214	5214	62143	187.3	149.2	58.7	17.5	76.2	69.9	27.0	87.3	155.6	130.2	5/8	7.44	
2 7/8		SF-46	2-214														
2 15/16	75	SF-47	2-215	14839	7 3/4	6	2 3/8	1	3 3/16	3 1/16	1 5/16	3 41/64	6 1/2	5 7/8	3/4	19.4	
		SF-215	5215	66004	196.9	152.4	60.3	25.4	81.0	77.8	33.3	92.5	165.1	149.2	3/4	8.80	

For Standard Duty Bearing Inserts-Single Lock see page G-92.
 *To obtain bolt circle, multiply B x 1.414".

Metric dimensions for reference only.

Performance Mounted Ball Bearings



Mtd. Ball Bearings



- Duty:** Standard
- Rolling Elements:** Ball
- Housing:** Cast Iron Four Bolt Flange
- Self Alignment:** +/- 2 Degrees
- Lock:** SKWEZLOC Locking Collar
- Seal:** Felt
- Optional Seal:** Contact
- Temperature:** -20° to 220°F

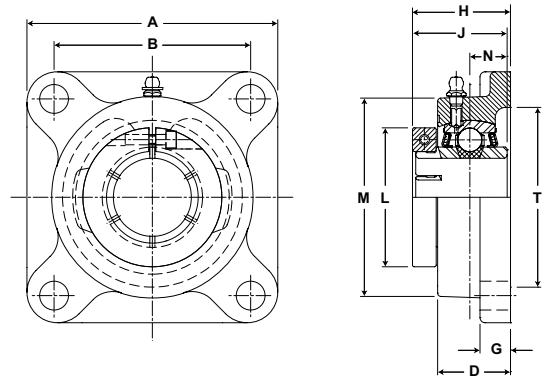

SF-T Series Standard Duty Four Bolt Flange - SKWEZLOC Locking Collar - Inch

Bore Diameter inch	Part No.	Bearing Insert No.	Basic Dynamic Rating lb/N	Dimensions inch / mm											Bolt Size	Unit Wt. lb/kg
				A	B*	D	G	H	J	L	M	N	T Core			
3/4	SF-12T	2-012T	2611 11614	3 3/8 85.7	2 1/2 63.5	59/64 23.4	7/16 11.1	1 11/32 34.1	1 9/32 32.5	1 3/4 44.5	2 11/32 59.5	1/2 12.7	2 50.8	3/8	1.6 .73	
15/16 1	SF-15T SF-16T	2-015T 2-1T	2801 12459	3 3/4 95.3	2 3/4 69.9	1 1/32 26.2	17/32 13.5	1 1/2 38.1	1 7/16 36.5	1 15/16 49.2	2 23/32 69.1	9/16 14.3	2 3/8 60.3	7/16	2.3 1.04	
1 1/8 1 3/16 1 1/4	SF-18T SF-19T SF-20RT	2-12T 2-13T 1-14T	4381 19487	4 1/4 108.0	3 1/4 82.6	1 11/64 29.8	17/32 13.5	1 5/8 41.3	1 9/16 39.7	2 3/16 55.6	3 7/32 81.8	5/8 15.9	2 7/8 73.0	7/16	3.8 1.72	
1 1/4	SF-20T	2-14T	5782 25718	4 5/8 117.5	3 5/8 92.1	1 11/32 34.1	9/16 14.3	1 13/16 46.0	1 3/4 44.5	2 7/16 61.9	3 23/32 94.5	11/16 17.5	3 5/16 84.1	1/2	4.4 2.00	
1 3/8 1 7/16	SF-22T SF-23T	2-16T 2-17T	5782 25718	4 5/8 117.5	3 5/8 92.1	1 11/32 34.1	9/16 14.3	1 13/16 46.0	1 3/4 44.5	2 9/16 65.1	3 23/32 94.5	11/16 17.5	3 5/16 84.1	1/2	4.4 2.00	
1 1/2	SF-24T	2-18T	7340 32648	5 1/8 130.2	4 101.6	1 1/2 38.1	9/16 14.3	2 5/64 52.8	2 50.8	2 11/16 68.3	4 1/8 104.8	3/4 19.1	3 1/2 88.9	1/2	5.8 2.63	
1 5/8	SF-26T	2-110T	7901 35144	5 3/8 136.5	4 1/8 104.8	1 9/16 39.7	9/16 14.3	2 7/64 53.6	2 50.8	2 13/16 71.4	4 21/64 109.9	3/4 19.1	3 7/8 98.4	9/16	6.0 2.72	
1 11/16 1 3/4	SF-27T SF-28T	2-111T 2-112T	7901 35144	5 3/8 136.5	4 1/8 104.8	1 9/16 39.7	9/16 14.3	2 7/64 53.6	2 50.8	2 15/16 74.6	4 21/64 109.9	3/4 19.1	3 7/8 98.4	9/16	6.0 2.72	
1 15/16 2	SF-31T SF-32RT	2-115T 1-2T	7889 35090	5 5/8 142.9	4 3/8 111.1	1 9/16 39.7	9/16 14.3	2 7/32 56.4	2 3/32 53.2	3 3/8 85.7	4 33/64 114.7	3/4 19.1	4 101.6	9/16	7.0 3.18	
2	SF-32T	2-2T	9752 43377	6 3/8 161.9	5 1/8 130.2	1 3/4 44.5	13/16 20.6	2 3/8 60.3	2 1/4 57.2	3 1/2 88.9	5 3/16 131.8	7/8 22.2	4 1/4 108.0	5/8	11.1 5.03	
2 1/8 2 3/16	SF-34T SF-35T	2-22T 2-23T	9752 43377	6 3/8 161.9	5 1/8 130.2	1 3/4 44.5	13/16 20.6	2 3/8 60.3	2 1/4 57.2	3 5/8 92.1	5 3/16 131.8	7/8 22.2	4 1/4 108.0	5/8	11.1 5.03	
2 1/4	SF-36T	2-24T	11789 52437	6 7/8 174.6	5 5/8 142.9	1 15/16 49.2	13/16 20.6	2 3/4 69.9	2 5/8 66.7	4 1/16 103.2	5 7/16 138.1	1 25.4	5 127.0	5/8	13.0 5.90	
2 3/8 2 7/16	SF-38T SF-39T	2-26T 2-27T	11789 52437	6 7/8 174.6	5 5/8 142.9	1 15/16 49.2	13/16 20.6	2 3/4 69.9	2 5/8 66.7	4 1/8 104.8	5 7/16 138.1	1 25.4	5 127.0	5/8	13.0 5.90	

SF-T Series Standard Four Bolt Flange - SKWEZLOC Locking Collar - Metric -SKWEZ™

Bore Diameter mm	Part No.	Bearing Insert No.	Basic Dynamic Rating N/lb	Dimensions mm / inch											Bolt Size	Unit Wt. kg/lb
				A	B*	D	G	H	J	L	M	N	T Core			
20	SF-204TMC	5204TMC	11614 2611	85.7 3 3/8	63.5 2 1/2	23.4 59/64	11.1 7/16	34.1 1 11/32	32.5 1 9/32	44.5 1 3/4	59.5 2 11/32	12.7 1/2	50.8 2	M10	.73 1.6	
25	SF-205TMC	5205TMC	12459 2801	95.3 3 3/4	69.9 2 3/4	26.2 1 1/32	13.5 17/32	38.1 1 1/2	36.5 1 7/16	49.2 1 15/16	69.1 2 23/32	14.3 9/16	60.3 2 3/8	M10	1.04 2.3	
30	SF-206TMC	5206TMC	19487 4381	108.0 4 1/4	82.6 3 1/4	29.8 1 11/64	13.5 17/32	41.3 1 5/8	39.7 1 9/16	55.6 2 3/16	81.8 3 7/32	15.9 5/8	73.0 2 7/8	M12	1.72 3.8	
35	SF-207TMC	5207TMC	25718 5782	117.5 4 5/8	92.1 3 5/8	34.1 1 11/32	14.3 9/16	46.0 1 13/16	44.5 1 3/4	65.1 2 9/16	94.5 3 23/32	17.5 11/16	84.1 3 5/16	M14	2.00 4.4	
40	SF-208TMC	5208TMC	32648 7340	130.2 5 1/8	101.6 4	38.1 1 1/2	14.3 9/16	52.8 2 5/64	50.8 2	68.3 2 11/16	81.8 103.6	19.1 3/4	88.9 3 1/2	M14	2.63 5.8	
45	SF-209TMC	5209TMC	35144 7901	136.5 5 3/8	104.8 4 1/8	39.7 1 9/16	14.3 9/16	53.6 2 7/64	50.8 2	74.6 2 15/16	109.9 4 21/64	19.1 3/4	98.4 3 7/8	M14	2.72 6.0	
50	SF-210TMC	5210TMC	35090 7889	142.9 5 5/8	111.1 4 3/8	39.7 1 9/16	14.3 9/16	56.4 2 7/32	53.2 2 3/32	85.7 3 3/8	114.7 4 33/64	19.1 3/4	101.6 4	M16	3.18 7.0	
55	SF-211TMC	5211TMC	43377 9752	161.9 6 3/8	130.2 5 1/8	44.5 1 3/4	13/16 20.6	60.3 2 3/8	57.2 2 1/4	92.1 3 5/8	131.8 5 3/16	22.2 7/8	108.0 4 1/4	M16	5.03 11.1	
60	SF-212TMC	5212TMC	52437 11789	174.6 6 7/8	142.9 5 5/8	49.2 1 15/16	13/16 20.6	69.9 2 3/4	66.7 2 5/8	104.8 4 1/8	138.1 5 7/16	25.4 1	127.0 5	M16	5.90 13.0	

For standard duty SKWEZLOC Locking Collar Bearing Inserts see page G-93.
To obtain bolt circle, multiply B x 1.414.

SEALMASTER® Performance Mounted Ball Bearings



Duty: Medium
Rolling Elements: Ball
Housing: Cast Iron Four Bolt Flange
Self Alignment: +/- 2 Degrees
Lock: Setscrew
Seal: Felt
Optional Seal: Contact
Temperature: -20° to 220°F

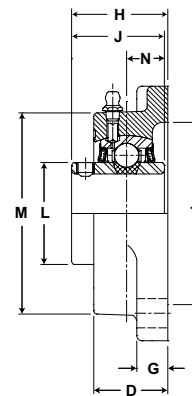
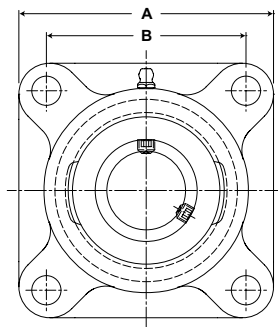

MSF Series Medium Duty Four-Bolt Flange Units - Setscrew Locking

Bore Diameter		Part No.	Bearing Insert No.	Basic Dynamic Rating lb/N	Dimensions inch / mm										Bolt Size	Unit Wt. lb/kg
inch	mm				A	B*	D	G	H	J	N	L	M	T Core		
15/16		MSF-15	3-015	4381	4 1/4	3 1/4	1 11/64	17/32	1 9/16	1 1/2	5/8	1 19/32	3 7/32	2 7/8	7/16	3.6 1.63
1	25	MSF-16	3-1	19487	108.0	82.6	29.8	13.5	39.7	38.1	15.9	40.5	81.8	73.0		
		MSF-305	5305													
1 3/16		MSF-19	3-13	5782	4 5/8	3 5/8	1 11/32	9/16	1 3/4	1 11/16	11/16	1 55/64	3 23/32	3 5/16	1/2	4.1 1.86
1 1/4	30	MSF-20	2-14	25718	117.5	92.1	34.1	14.3	44.5	42.9	17.5	47.2	94.5	84.1		
		MSF-306	5306													
1 7/16		MSF-23	3-17	7340	5 1/8	4	1 1/2	9/16	2 1/64	1 15/16	3/4	2 1/16	4 5/64	3 1/2	1/2	5.5 2.49
	35	MSF-307	5307	32648	130.2	101.6	38.1	14.3	51.2	49.2	19.1	52.4	103.6	88.9		
1 1/2		MSF-24	3-18	7901	5 3/8	4 1/8	1 9/16	9/16	2 3/64	1 15/16	3/4	2 19/64	4 21/64	3 7/8	9/16	6.0 2.72
	40	MSF-308	5308	35144	136.5	104.8	39.7	14.3	52.0	49.2	19.1	58.3	109.9	98.4		
1 11/16		MSF-27	3-111	7889	5 5/8	4 3/8	1 9/16	9/16	2 5/32	2 1/32	3/4	2 15/32	4 33/64	4	9/16	6.8 3.08
1 3/4	45	MSF-28	3-112	35090	142.9	111.1	39.7	14.3	54.8	51.6	19.1	62.7	114.7	101.6		
		MSF-309	5309													
1 15/16		MSF-31	3-115	9752	6 3/8	5 1/8	1 3/4	13/16	2 5/16	2 3/16	7/8	2 23/32	5 3/16	4 1/4	5/8	10.5 4.76
2	50	MSF-32	2-2	43377	161.9	130.2	44.5	20.6	58.7	55.6	22.2	69.1	131.8	108.0		
		MSF-310	5310													
2 3/16		MSF-35	3-23	11789	6 7/8	5 5/8	1 15/16	13/16	2 11/16	2 9/16	1	2 63/64	5 7/16	5	5/8	12.1 5.49
2 1/4	55	MSF-36	2-24	52437	174.6	142.9	49.2	20.6	68.3	65.1	25.4	75.8	138.1	127.0		
		MSF-311	5311													
2 7/16		MSF-39	3-27	13971	7 3/8	5 7/8	2 5/16	11/16	3	2 3/4	1 1/16	3 7/16	6 1/8	5 10/77	5/8	16.4 7.44
2 1/2	65	MSF-40	3-28	62143	187.3	149.2	58.7	17.5	76.2	69.9	27.0	87.3	155.6	130.3		
		MSF-313	5313													
2 11/16		MSF-43	3-211	14839	7 3/4	6	2 3/8	1	3 3/16	3 1/16	1 5/16	3 41/64	6 1/2	5 22/25	3/4	20.6 9.34
	70	MSF-314	5314	66004	196.9	152.4	60.3	25.4	81.0	77.8	33.3	92.5	165.1	149.4		
2 15/16		MSF-47	3-215	17412	7 3/4	6	2 11/16	7/8	3 1/2	3 1/4	1 5/16	3 59/64	6 3/4	5 14/25	3/4	21.4 9.71
3	75	MSF-48	3-3	77449	196.9	152.4	68.3	22.2	88.9	82.6	33.3	99.6	171.5	141.2		
		MSF-315	5315													
3 3/16		MSF-51	3-33	18681	8 7/16	6 3/4	2 3/4	1	3 17/32	3 3/8	1 11/32	4 5/32	7 1/4	6	3/4	26.7 12.11
3 1/4	80	MSF-52	2-34	83093	214.3	171.5	69.9	25.4	89.7	85.7	34.1	105.6	184.2	152.4		
		MSF-316	5316													
3 7/16		MSF-55	3-37	21566	8 7/16	6 3/4	3	1	3 31/32	3 25/32	1 9/16	4 25/64	7 3/4	6 22/71	7/8	30.0 13.61
3 1/2		MSF-56	3-38	95926	214.3	171.5	76.2	25.4	100.8	96.0	39.7	111.5	196.9	160.3		
3 15/16		MSF-63	3-315	29905	10 9/16	8 5/16	3 13/16	1 1/4	5	4 5/8	1 15/16	5 11/64	9 1/4	7 11/25	1	55.1 24.99
4	100	MSF-64	3-4	133017	268.3	211.1	96.8	31.8	127.0	117.5	49.2	131.4	235.0	189.0		
		MSF-320	5320													
4 7/16		MSFD-71	3-47D	37482	12 3/4	10	4 3/4	1 9/16	6	5 3/4	2 7/8	6 11/32	11 1/2	9 1/2	1 1/4 32	115.0 52.16
4 15/16		MSFD-79	3-415D	166720	323.9	254.0	120.7	39.7	152.4	146.1	73.0	161.1	292.1	241.3		

Units MSFD-71 and MSFD-79 are equipped with four set screws: two on each end of inner race extensions.

Units MSFD-71 and MSFD-79 are not available with contact seal.

*To obtain bolt circle, multiply B x 1.414".

For Medium Duty Bearing Inserts-Single Lock see page G-95.

For Medium Duty Bearing Inserts-Double Lock see page G-97.

Metric dimensions for reference only.

Not all parts are available from stock. Please contact customer service for availability (800) 626-2120.

For more information on bearing capabilities outside of our standard offering, please contact Application Engineering (800) 626-2093.

Performance Mounted Ball Bearings **SEALMASTER**®



- Duty:** Medium
- Rolling Elements:** Ball
- Housing:** Cast Iron Four Bolt Flange
- Self Alignment:** +/- 2 Degrees
- Lock:** SKWEZLOC Locking Collar
- Seal:** Felt
- Optional Seal:** Contact
- Temperature:** -20° to 220°F

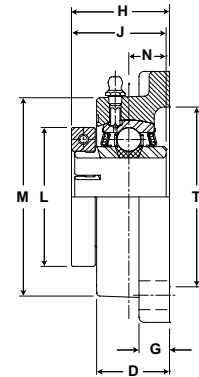
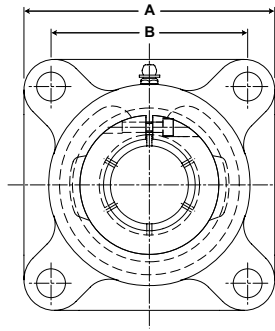

MSF-T Series Medium Duty Four-Bolt Flange Units - SKWEZLOC Locking Collar

Bore Diameter inch	Part No.	Bearing Insert No.	Basic Dynamic Rating lb/N	Dimensions inch / mm										Bolt Size	Unit Wt. lb/kg
				A	B*	D	G	H	J	N	L	M	T Core		
1	MSF-16T	3-1T	4381 19487	4 1/4 108.0	3 1/4 82.6	1 11/64 29.8	17/32 13.5	1 5/8 41.3	1 9/16 39.7	5/8 15.9	2 1/16 52.4	3 7/32 81.8	2 7/8 73.0	7/16	3.8 1.72
1 3/16 1 1/4	MSF-19T MSF-20T	3-13T 2-14T	5782 25718	4 5/8 117.5	3 5/8 92.1	1 11/32 34.1	9/16 14.3	1 13/16 46.0	1 3/4 44.5	11/16 17.5	2 7/16 61.9	3 23/32 94.5	3 5/16 84.1	1/2	4.4 2.00
1 7/16	MSF-23T	3-17T	7340 32648	5 1/8 130.2	4 101.6	1 1/2 38.1	9/16 14.3	2 5/64 52.8	2 50.8	3/4 19.1	2 11/16 68.3	4 1/8 104.8	3 1/2 88.9	1/2	5.8 2.63
1 1/2	MSF-24T	3-18T	7901 35144	5 3/8 136.5	4 1/8 104.8	1 9/16 39.7	9/16 14.3	2 7/64 53.6	2 50.8	3/4 19.1	2 13/16 71.4	4 21/64 109.9	3 7/8 98.4	9/16	6.3 2.86
1 11/16 1 3/4	MSF-27T MSF-28T	3-111T 3-112T	7889 35090	5 5/8 142.9	4 3/8 111.1	1 9/16 39.7	9/16 14.3	2 7/32 56.4	2 3/32 53.2	3/4 19.1	3 1/4 82.6	4 33/64 114.7	4 101.6	9/16	7.4 3.36
1 15/16 2	MSF-31T MSF-32T	3-115T 2-2T	9752 43377	6 3/8 161.9	5 1/8 130.2	1 3/4 44.5	13/16 20.6	2 3/8 60.3	2 1/4 57.2	7/8 22.2	3 1/2 88.9	5 3/16 131.8	4 1/4 108.0	5/8	11.1 5.03
2 3/16 2 1/4	MSF-35T MSF-36T	3-23T 2-24T	11789 52437	6 7/8 174.6	5 5/8 142.9	1 15/16 49.2	13/16 20.6	2 3/4 69.9	2 5/8 66.7	1 25.4	4 1/16 103.2	5 7/16 138.1	5 127.0	5/8	13.3 6.03

For Medium Duty SKWEZLOC Locking Collar Bearing Inserts see page G-96.
*To obtain bolt circle, multiply B x 1.414".

SEALMASTER® Performance Mounted Ball Bearings



- Duty:** Standard
- Rolling Elements:** Ball
- Housing:** Cast Iron Two Bolt Flange
- Self Alignment:** +/- 2 Degrees
- Lock:** Setscrew
- Seal:** Felt
- Optional Seal:** Contact
- Temperature:** -20° to 220°F

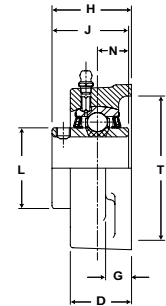
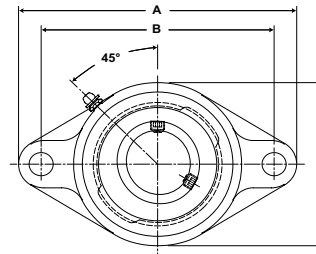

SFT Series Standard Duty Two-Bolt Flange Units - Setscrew Locking

Bore Diameter		Part No.	Bearing Insert No.	Basic Dynamic Rating lb/N	Dimensions inch / mm										Bolt Size	Unit Wt. lb/kg
inch	mm				A	B	C	D	G	H	J	N	L	T Core		
1/2		SFT-8	2-08	2611 11614	3 7/8 98.4	3 76.2	2 5/16 58.7	59/64 23.4	7/16 11.1	1 9/32 32.5	1 7/32 31.0	1/2 12.7	1 3/16 30.2	2 50.8	3/8	1.2 .54
9/16		SFT-9	2-09													
5/8		SFT-10	2-010													
11/16		SFT-11	2-011													
3/4	20	SFT-12	2-012	2611	4 13/32	3 17/32	2 3/8	59/64	7/16	1 9/32	1 7/32	1/2	1 3/16	2	3/8	1.2
		SFT-204	5204	11614	111.9	89.7	60.3	23.4	11.1	32.5	31.0	12.7	30.2	50.8		.54
13/16		SFT-13	2-013	2801 12459	4 7/8 123.8	3 57/64 98.8	2 3/4 69.9	1 1/32 26.2	17/32 13.5	1 7/16 36.5	1 3/8 34.9	9/16 14.3	1 3/8 34.9	2 3/8 60.3	7/16	1.6 .73
7/8		SFT-14	2-014													
15/16		SFT-15	2-015													
1	25	SFT-16	2-1													
		SFT-205	5205													
1 1/16		SFT-17	2-11	4381 19487	5 9/16 141.3	4 19/32 116.7	3 1/4 82.6	1 11/64 29.8	17/32 13.5	1 9/16 39.7	1 1/2 38.1	5/8 15.9	1 19/32 40.5	2 7/8 73.0	7/16	2.2 1.00
1 1/8		SFT-18	2-12													
1 3/16		SFT-19	2-13													
1 1/4	30	SFT-20R	1-14													
		SFT-206	5206													
1 1/4		SFT-20	2-14	5782 25718	6 1/8 155.6	5 1/8 130.2	3 3/4 95.3	1 11/32 34.1	9/16 14.3	1 3/4 44.5	1 11/16 42.9	11/16 17.5	1 55/64 47.2	3 5/16 84.1	1/2	3.2 1.45
1 5/16		SFT-21	2-15													
1 3/8		SFT-22	2-16													
1 7/16	35	SFT-23	2-17													
		SFT-207	5207													
1 1/2		SFT-24	2-18	7340 32648	6 3/4 171.5	5 21/32 143.7	4 1/8 104.8	1 1/2 38.1	9/16 14.3	2 1/64 51.2	1 15/16 49.2	3/4 19.1	2 1/16 52.4	3 1/2 88.9	1/2	4.5 2.04
1 9/16	40	SFT-25	2-19													
		SFT-208	5208													
1 5/8		SFT-26	2-110	7901 35144	7 1/16 179.4	5 27/32 148.4	4 3/8 111.1	1 9/16 39.7	9/16 14.3	2 3/64 52.0	1 15/16 49.2	3/4 19.1	2 19/64 58.3	3 7/8 98.4	9/16	5 2.27
1 11/16		SFT-27	2-111													
1 3/4	45	SFT-28	2-112													
		SFT-209	5209													
1 13/16		SFT-29	2-113	7889 35090	7 7/16 188.9	6 3/16 157.2	4 9/16 115.9	1 9/16 39.7	9/16 14.3	2 5/32 54.8	2 1/32 51.6	3/4 19.1	2 15/32 62.7	4 101.6	9/16	5.4 2.45
1 7/8		SFT-30	2-114													
1 15/16		SFT-31	2-115													
2	50	SFT-32R	1-2													
		SFT-210	5210													
2		SFT-32	2-2	9752 43377	8 1/2 215.9	7 1/4 184.2	5 1/4 133.4	1 3/4 44.5	13/16 20.6	2 5/16 58.7	2 3/16 55.6	7/8 22.2	2 23/32 69.1	4 1/4 108.0	5/8	8.4 3.81
2 1/8		SFT-34	2-22													
2 3/16		SFT-35	2-23													
	55	SFT-211	5211													

For Standard Duty Bearing Inserts-Single Lock see page G-92.

Metric dimensions for reference only.

Not all parts are available from stock. Please contact customer service for availability (800) 626-2120.

For more information on bearing capabilities outside of our standard offering, please contact Application Engineering (800) 626-2093.



- Duty:** Standard
- Rolling Elements:** Ball
- Housing:** Cast Iron Two Bolt Flange
- Self Alignment:** +/- 2 Degrees
- Lock:** SKWEZLOC Locking Collar
- Seal:** Felt
- Optional Seal:** Contact
- Temperature:** -20° to 220°F

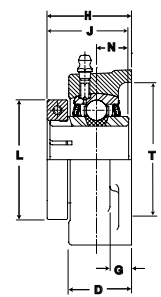
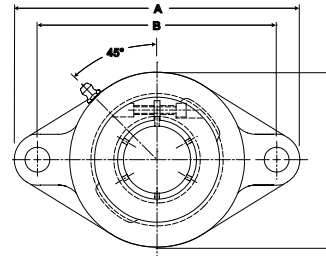

SFT-T Series Standard Duty Two Bolt Flange - SKWEZLOC Locking Collar - Inch

Bore Diameter inch	Part No.	Bearing Insert No.	Basic Dynamic Rating lb/N	Dimensions inch / mm										Bolt Size	Unit Wt. lb/kg
				A	B	C	D	G	H	J	L	N	T Core		
3/4	SFT-12T	2-012T	2611 11614	4 13/32 111.9	3 17/32 89.7	2 3/8 60.3	59/64 23.4	7/16 11.1	1 11/32 34.1	1 9/32 32.5	1 3/4 44.5	1/2 12.7	2 50.8	3/8	1.3 .59
15/16 1	SFT-15T SFT-16T	2-015T 2-1T	2801 12459	4 7/8 123.8	3 57/64 98.8	2 3/4 69.9	1 1/32 26.2	17/32 13.5	1 1/2 38.1	1 7/16 36.5	1 15/16 49.2	9/16 14.3	2 3/8 60.3	7/16	1.8 .82
1 1/8 1 3/16 1 1/4	SFT-18T SFT-19T SFT-20RT	2-12T 2-13T 1-14T	4381 19487	5 9/16 141.3	4 19/32 116.7	3 1/4 82.6	1 11/64 29.8	17/32 13.5	1 5/8 41.3	1 9/16 39.7	2 3/16 55.6	5/8 15.9	2 7/8 73.0	7/16	2.4 1.09
1 1/4	SFT-20T	2-14T	5782 25718	6 1/8 155.6	5 1/8 130.2	3 3/4 95.3	1 11/32 34.1	9/16 14.3	1 13/16 46.0	1 3/4 44.5	2 7/16 61.9	11/16 17.5	3 5/16 84.1	1/2	3.5 1.59
1 3/8 1 7/16	SFT-22T SFT-23T	2-16T 2-17T	5782 25718	6 1/8 155.6	5 1/8 130.2	3 3/4 95.3	1 11/32 34.1	9/16 14.3	1 13/16 46.0	1 3/4 44.5	2 9/16 65.1	11/16 17.5	3 5/16 84.1	1/2	3.5 1.59
1 1/2	SFT-24T	2-18T	7340 32648	6 3/4 171.5	5 21/32 143.7	4 1/8 104.8	1 1/2 38.1	9/16 14.3	2 5/64 52.8	2 50.8	2 11/16 68.3	3/4 19.1	3 1/2 88.9	1/2	4.8 2.18
1 5/8	SFT-26T	2-110T	7901 35144	7 1/16 179.4	5 27/32 148.4	4 3/8 111.1	1 9/16 39.7	9/16 14.3	2 7/64 53.6	2 50.8	2 13/16 71.4	3/4 19.1	3 7/8 98.4	9/16	5.3 2.40
1 11/16 1 3/4	SFT-27T SFT-28T	2-111T 2-112T	7901 35144	7 1/16 179.4	5 27/32 148.4	4 3/8 111.1	1 9/16 39.7	9/16 14.3	2 7/64 53.6	2 50.8	2 15/16 74.6	3/4 19.1	3 7/8 98.4	9/16	5.3 2.40
1 15/16 2	SFT-31T SFT-32RT	2-115T 1-2T	7889 35090	7 7/16 188.9	6 3/16 157.2	4 9/16 115.9	1 9/16 39.7	9/16 14.3	2 7/32 56.4	2 3/32 53.2	3 3/8 85.7	3/4 19.1	4 101.6	9/16	6 2.72
2	SFT-32T	2-2T	9752 43377	8 1/2 215.9	7 1/4 184.2	5 1/4 133.4	1 3/4 44.5	13/16 20.6	2 3/8 60.3	2 1/4 57.2	3 1/2 88.9	7/8 22.2	4 1/4 108.0	5/8	9 4.08
2 1/8 2 3/16	SFT-34T SFT-35T	2-22T 2-23T	9752 43377	8 1/2 215.9	7 1/4 184.2	5 1/4 133.4	1 3/4 44.5	13/16 20.6	2 3/8 60.3	2 1/4 57.2	3 5/8 92.1	7/8 22.2	4 1/4 108.0	5/8	9 4.08

SFT-T Series Standard Two Bolt Flange - SKWEZLOC Locking Collar - Metric -SKWEZ™

Bore Diameter mm	Part No.	Bearing Insert No.	Basic Dynamic Rating N/lb	Dimensions mm / inch										Bolt Size	Unit Wt. kg/lb
				A	B	C	D	G	H	J	L	N	T Core		
20	SFT-204TMC	5204TMC	11614 2611	111.9 4 13/32	89.7 3 17/32	60.3 2 3/8	23.4 59/64	11.1 7/16	34.1 1 11/32	32.5 1 9/32	44.5 1 3/4	12.7 1/2	50.8 2	M10	.59 1.3
25	SFT-205TMC	5205TMC	12459 2801	123.8 4 7/8	98.8 3 57/64	69.9 2 3/4	26.2 1 1/32	13.5 17/32	38.1 1 1/2	36.5 1 7/16	49.2 1 15/16	14.3 9/16	60.3 2 3/8	M10	.82 1.8
30	SFT-206TMC	5206TMC	19487 4381	141.3 5 9/16	116.7 4 19/32	82.6 3 1/4	29.8 1 11/64	13.5 17/32	41.3 1 5/8	39.7 1 9/16	55.6 2 3/16	15.9 5/8	73.0 2 7/8	M12	1.09 2.4
35	SFT-207TMC	5207TMC	25718 5782	155.6 6 1/8	130.2 5 1/8	95.3 3 3/4	34.1 1 11/32	14.3 9/16	46.0 1 13/16	44.5 1 3/4	65.1 2 9/16	17.5 11/16	84.1 3 5/16	M14	1.59 3.5
40	SFT-208TMC	5208TMC	32648 7340	171.5 6 3/4	143.7 5 21/32	104.8 4 1/8	38.1 1 1/2	14.3 9/16	52.8 2 5/64	50.8 2	68.3 2 11/16	19.1 3/4	88.9 3 1/2	M14	2.18 4.8
45	SFT-209TMC	5209TMC	35144 7901	179.4 7 1/16	148.4 5 27/32	111.1 4 3/8	39.7 1 9/16	14.3 9/16	53.6 2 7/64	50.8 2	74.6 2 15/16	19.1 3/4	98.4 3 7/8	M14	2.40 5.3
50	SFT-210TMC	5210TMC	35090 7889	188.9 7 7/16	157.2 6 3/16	115.9 4 9/16	39.7 1 9/16	14.3 9/16	56.4 2 7/32	53.2 2 3/32	85.7 3 3/8	19.1 3/4	101.6 4	M16	2.72 6
55	SFT-211TMC	5211TMC	43377 9752	215.9 8 1/2	184.2 7 1/4	133.4 5 1/4	44.5 1 3/4	20.6 13/16	60.3 2 3/8	57.2 2 1/4	92.1 3 5/8	22.2 7/8	108.0 4 1/4	M16	4.08 9

For Medium Duty SKWEZLOC Locking Collar Bearing Inserts see page G-93.

SEALMASTER® Performance Mounted Ball Bearings



Duty: Medium
Rolling Elements: Ball
Housing: Cast Iron Two Bolt Flange
Self Alignment: +/- 2 Degrees
Lock: Setscrew
Seal: Felt
Optional Seal: Contact
Temperature: -20° to 220°F

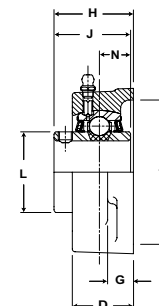
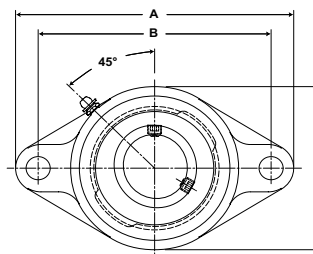

MSFT Series Medium Duty Two-Bolt Flange Units - Setscrew Locking

Bore Diameter		Part No.	Bearing Insert No.	Basic Dynamic Rating lb/N	Dimensions inch / mm										Bolt Size	Unit Wt. lb/kg
inch	mm				A	B	C	D	G	H	J	N	L	T Core		
15/16		MSFT-15	3-015	4381	5 9/16	4 19/32	3 1/4	1 11/64	17/32	1 9/16	1 1/2	5/8	1 19/32	2 7/8	7/16	2.4 1.09
1		MSFT-16	3-1	19487	141.3	116.7	82.6	29.8	13.5	39.7	38.1	15.9	40.5	73.0		
	25	MSFT-305	5305													

Metric dimensions for reference only.

Not all parts are available from stock. Please contact customer service for availability (800) 626-2120.

For more information on bearing capabilities outside of our standard offering, please contact Application Engineering (800) 626-2093.



- Duty:** Medium
- Rolling Elements:** Ball
- Housing:** Cast Iron Two Bolt Flange
- Self Alignment:** +/- 2 Degrees
- Lock:** SKWEZLOC Locking Collar
- Seal:** Felt
- Optional Seal:** Contact
- Temperature:** -20° to 220°F

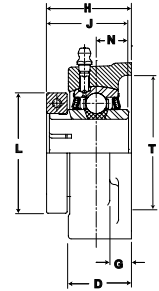
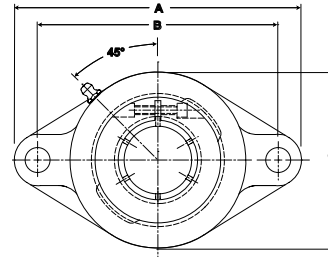

MSFT-T Series Medium Duty Two-Bolt Flange Units - SKWEZLOC Locking Collar

Bore Diameter inch	Part No.	Bearing Insert No.	Basic Dynamic Rating lb/N	Dimensions inch / mm										Bolt Size	Unit Wt. lb/kg
				A	B	C	D	G	H	J	N	L	T Core		
1	MSFT-16T	3-1T	4381	5 9/16	4 19/32	3 1/4	1 11/64	17/32	1 5/8	1 9/16	5/8	2 1/16	2 7/8	7/16	2.6
			19487	141.3	116.7	82.6	29.8	13.5	41.3	39.7	15.9	52.4	73.0		1.18
1 3/16	MSFT-19T	3-13T	5782	6 1/8	5 1/8	3 3/4	1 11/32	9/16	1 13/16	1 3/4	11/16	2 7/16	3 5/16	1/2	3.7
1 1/4	MSFT-20T	2-14T	25718	155.6	130.2	95.3	34.1	14.3	46.0	44.5	17.5	61.9	84.1		1.68
1 7/16	MSFT-23T	3-17T	7340	6 3/4	5 21/32	4 1/8	1 1/2	9/16	2 5/64	2	3/4	2 11/16	3 1/2	1/2	4.9
			32648	171.5	143.7	104.8	38.1	14.3	52.8	50.8	19.1	68.3	88.9		2.22
1 1/2	MSFT-24T	3-18T	7901	7 1/16	5 27/32	4 3/8	1 9/16	9/16	2 7/64	2	3/4	2 13/16	3 7/8	9/16	5.5
			35144	179.4	148.4	111.1	39.7	14.3	53.6	50.8	19.1	71.4	98.4		2.49
1 11/16	MSFT-27T	3-111T	7889	7 7/16	6 3/16	4 9/16	1 9/16	9/16	2 7/32	2 3/32	3/4	3 1/4	4	9/16	6.2
1 3/4	MSFT-28T	3-112T	35090	188.9	157.2	115.9	39.7	14.3	56.4	53.2	19.1	82.6	101.6		2.81
1 15/16	MSFT-31T	3-115T	9752	8 1/2	7 1/4	5 1/4	1 3/4	13/16	2 3/8	2 1/4	7/8	3 1/2	4 1/4	5/8	9.2
2	MSFT-32T	2-2T	43377	215.9	184.2	133.4	44.5	20.6	60.3	57.2	22.2	88.9	108.0		4.17

For Medium Duty SKWEZLOC Locking Collar Bearing Inserts see page G-96.

SEALMASTER® Performance Mounted Ball Bearings



Duty: Standard
Rolling Elements: Ball
Housing: Cast Iron Flange Bracket
Self Alignment: +/- 2 Degrees
Lock: Setscrew
Seal: Felt
Optional Seal: Contact
Temperature: -20° to 220°F

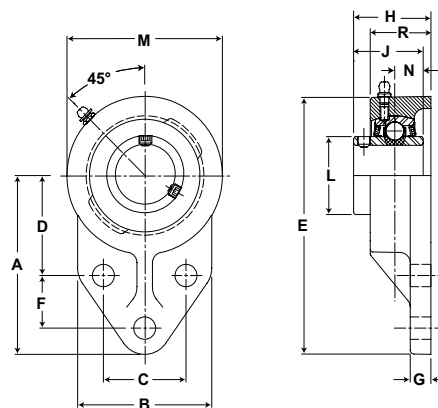

FB Series Standard Duty Three Bolt Single Lock Flange Brackets - Setscrew Locking

Bore Diameter		Part No.	Bearing Insert No.	Basic Dynamic Rating lb/N	Dimensions inch / mm													Bolt Size	Unit Wt. lb/kg
inch	mm				A	B	C	D	E	F	G	H	J	L	M	N	R		
1/2		FB-8	2-08																
9/16		FB-9	2-09																
5/8		FB-10	2-010	2611	3	2 3/8	1 1/2	1 11/16	4 3/16	7/8	5/16	1 11/32	1 7/32	1 3/16	2 3/8	1/2	1	3/8	1.3
11/16		FB-11	2-011	11614	76.2	60.3	38.1	42.9	106.4	22.2	7.9	34.1	31.0	30.2	60.3	12.7	25.4		0.59
3/4	20	FB-12	2-012																
		FB-204	5204																
13/16		FB-13	2-013																
7/8		FB-14	2-014																
15/16		FB-15	2-015	2801	3 3/8	2 1/2	1 5/8	1 13/16	4 3/4	1 1/8	3/8	1 1/2	1 3/8	1 3/8	2 3/4	9/16	1 3/32	3/8	2.1
1	25	FB-16	2-1	12459	85.7	63.5	41.3	46.0	120.7	28.6	9.5	38.1	34.9	34.9	69.9	14.3	27.8		0.95
		FB-205	5205																
1 1/16		FB-17	2-11																
1 1/8		FB-18	2-12																
1 3/16		FB-19	2-13	4381	3 3/4	2 3/4	1 7/8	2 1/16	5 23/64	1 1/4	3/8	1 5/8	1 1/2	1 19/32	3 7/32	5/8	1 15/64	3/8	3.0
1 1/4	30	FB-20R	1-14	19487	95.3	69.9	47.6	52.4	136.1	31.8	9.5	41.3	38.1	40.5	81.8	15.9	31.4		1.36
		FB-206	5206																
1 1/4		FB-20	2-14																
1 5/16		FB-21	2-15																
1 3/8		FB-22	2-16	5782	4 1/4	3 1/4	2	2 3/8	6 1/8	1 1/4	1/2	1 7/8	1 11/16	1 55/64	3 3/4	11/16	1 15/32	1/2	3.1
1 7/16	35	FB-23	2-17	25718	108.0	82.6	50.8	60.3	155.6	31.8	12.7	47.6	42.9	47.2	95.3	17.5	37.3		1.41
		FB-207	5207																
1 7/8		FB-30	2-114																
1 15/16		FB-31	2-115	7889	5 3/16	4	2 3/4	2 15/16	7 15/32	1 5/8	1/2	2 5/32	2 1/32	2 15/32	4 9/16	3/4	1 35/64	1/2	5.1
2	50	FB-32R	1-2	35090	131.8	101.6	69.9	74.6	189.7	41.3	12.7	54.8	51.6	62.7	115.9	19.1	39.3		2.31
		FB-210	5210																

For Standard Duty Bearing Inserts-Single Lock see page G-92.

Metric dimensions for reference only.

Not all parts are available from stock. Please contact customer service for availability (800) 626-2120.

For more information on bearing capabilities outside of our standard offering, please contact Application Engineering (800) 626-2093.



- Duty:** Standard
- Rolling Elements:** Ball
- Housing:** Cast Iron Flange Bracket
- Self Alignment:** +/- 2 Degrees
- Lock:** SKWEZLOC Locking Collar
- Seal:** Felt
- Optional Seal:** Contact
- Temperature:** -20° to 220°F

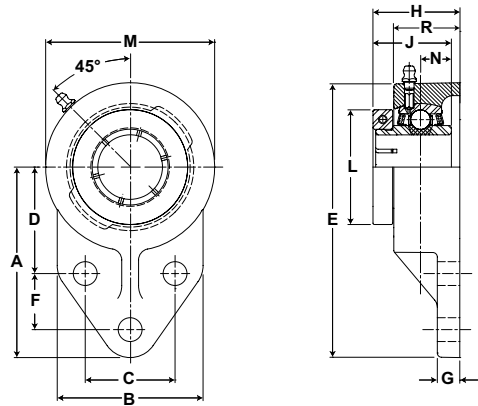

FB-T Series Standard Duty Flange Bracket - SKWEZLOC Locking Collar - Inch

Bore Diameter inch	Part No.	Bearing Insert No.	Basic Dynamic Rating lb/N	Dimensions inch / mm													Bolt Size	Unit Wt. lb/kg
				A	B	C	D	E	F	G	H	J	L	M	N	R		
3/4	FB-12T	2-012T	2611 11614	3 76.2	2 3/8 60.3	1 1/2 38.1	1 11/16 42.9	4 3/16 106.4	7/8 22.2	5/16 7.9	1 13/32 35.7	1 9/32 32.5	1 3/4 44.5	2 3/8 60.3	1/2 12.7	1 25.4	3/8	1.4 0.64
15/16 1	FB-15T FB-16T	2-015T 2-1T	2801 12459	3 3/8 85.7	2 1/2 63.5	1 5/8 41.3	1 13/16 46	4 3/4 120.7	1 1/8 28.6	3/8 9.5	1 9/16 39.7	1 7/16 36.5	1 15/16 49.2	2 3/4 69.9	9/16 14.3	1 1/8 27.8	3/8	2.3 1.04
1 1/8 1 3/16 1 1/4	FB-18T FB-19T FB-20RT	2-12T 2-13T 1-14T	4381 19487	3 3/4 95.3	2 3/4 69.9	1 7/8 47.6	2 1/16 52.4	5 23/64 136.1	1 1/4 31.8	3/8 9.5	1 11/16 42.9	1 9/16 39.7	2 3/16 55.6	3 7/32 81.8	5/8 15.9	1 1/4 31.8	3/8	3.2 1.45
1 1/4	FB-20T	2-14T	5782 25718	4 1/4 108.0	3 1/4 82.6	2 50.8	2 3/8 60.3	6 1/8 155.6	1 1/4 31.8	1/2 12.7	1 15/16 49.2	1 3/4 44.5	2 7/16 61.9	3 3/4 95.3	11/16 17.5	1 7/16 36.5	1/2	3.4 1.54
1 3/8 1 7/16	FB-22T FB-23T	2-16T 2-17T	5782 25718	4 1/4 108.0	3 1/4 82.6	2 50.8	2 3/8 60.3	6 1/8 155.6	1 1/4 31.8	1/2 12.7	1 15/16 49.2	1 3/4 44.5	2 9/16 65.1	3 3/4 95.3	11/16 17.5	1 1/2 37.3	1/2	3.4 1.54
1 15/16 2	FB-31T FB-32RT	2-115T 1-2T	7889 35090	5 3/16 131.8	4 101.6	2 3/4 69.9	2 15/16 74.6	7 15/32 189.7	1 5/8 41.3	1/2 12.7	2 7/32 56.4	2 3/32 53.2	3 3/8 85.7	4 9/16 115.9	3/4 19.1	1 35/64 39.3	1/2	5.7 2.59

FB-T Series Standard Flange Bracket - SKWEZLOC Locking Collar - Metric -SKWEZ™

Bore Diameter mm	Part No.	Bearing Insert No.	Basic Dynamic Rating N/lb	Dimensions mm / inch													Bolt Size	Unit Wt. kg/lb
				A	B	C	D	E	F	G	H	J	L	M	N	R		
20	FB-204TMC	5204TMC	11614 2611	76.2 3	60.3 2 3/8	32.1 1 17/64	42.1 1 21/32	106.4 4 3/16	27.0 1 1/16	7.9 5/16	35.7 1 13/32	32.5 1 9/32	44.5 1 3/4	60.3 2 3/8	12.7 1/2	25.4 1	M8	.64 1.4
25	FB-205TMC	5205TMC	12459 2801	85.7 3 3/8	63.5 2 1/2	34.1 1 11/32	44.8 1 49/64	120.7 4 3/4	27.0 1 1/16	9.5 3/8	39.7 1 9/16	36.5 1 7/16	49.2 1 15/16	69.9 2 3/4	14.3 9/16	27.8 1 1/8	M8	1.04 2.3
30	FB-206TMC	5206TMC	19487 4381	95.3 3 3/4	69.9 2 3/4	40.1 1 37/64	50 1 31/32	136.1 5 23/64	29.0 1 9/64	9.5 3/8	42.9 1 11/16	39.7 1 9/16	55.6 2 3/16	81.8 3 7/32	15.9 5/8	31.8 1 1/4	M8	1.45 3.2
35	FB-207TMC	5207TMC	25718 5782	108.0 4 1/4	82.6 3 1/4	46.0 1 13/16	55.2 2 11/64	155.6 6 1/8	32.1 1 17/64	12.7 1/2	49.2 1 15/16	44.5 1 3/4	65.1 2 9/16	95.3 3 3/4	17.5 11/16	37.3 1 1/2	M8	1.54 3.4
50	FB-210TMC	5210TMC	35090 7889	131.8 5 3/16	101.6 4	57.9 2 9/32	67.9 2 43/64	189.7 7 15/32	46.0 1 13/16	12.7 1/2	56.4 2 7/32	53.2 2 3/32	85.7 3 3/8	115.9 4 9/16	19.1 3/4	39.3 1 35/64	M10	2.59 5.7

For Medium Duty SKWEZLOC Locking Collar Bearing Inserts see page G-93.



Duty: Standard
Rolling Elements: Ball
Housing: Cast Iron Piloted Flange Cartridge
Self Alignment: +/- 2 Degrees
Lock: Setscrew
Seal: Felt
Optional Seal: Contact
Temperature: -20° to 220°F

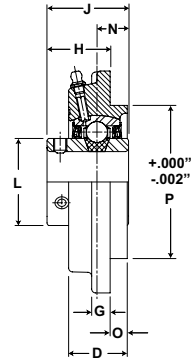
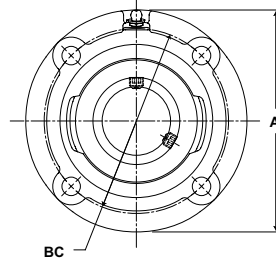

SFC Series Standard Duty Flange Cartridge Units - Setscrew Locking

Bore Diameter		Part No.	Bearing Insert No.	Basic Dynamic Rating lb/N	Dimensions inch / mm										Bolt Size	Unit Wt. lb/kg	
inch	mm				A	BC	D	G	H	J	L	N	O	P*			
1 1/8		SFC-18	2-12														
1 3/16		SFC-19	2-13	4381	4 3/8	3 5/8	1 11/64	3/8	1 5/16	1 9/16	1 19/32	5/8	1/4	3.000	5/16	3.0	
1 1/4	30	SFC-20R	1-14	19487	111.1	92.1	29.8	9.5	33.3	39.7	40.5	15.9	6.4	76.20		1.36	
		SFC-206	5206														
1 1/4	35	SFC-20	2-14														
1 5/16		SFC-21	2-15	5782	5	4 1/8	1 9/32	3/8	1 5/16	1 11/16	1 55/64	11/16	3/8	3.375	3/8	3.9	
1 3/8		SFC-22	2-16	25718	127.0	104.8	32.5	9.5	33.3	42.9	47.2	17.5	9.5	85.73		1.77	
1 7/16		SEF-23	2-17														
		SFC-207	5207														
1 1/2	40	SFC-24	2-18	7340	5 1/4	4 3/8	1 25/64	7/16	1 1/2	1 15/16	2 1/16	3/4	7/16	3.625	3/8	4.7	
1 9/16		SFC-25	2-19	32648	133.4	111.1	35.3	11.1	38.1	49.2	52.4	19.1	11.1	92.08		2.13	
		SFC-208	5208														
1 5/8	45	SFC-26	2-110														
1 11/16		SFC-27	2-111	7901	6 1/8	5 1/8	1 27/64	7/16	1 1/2	1 15/16	2 19/64	3/4	7/16	4.250	7/16	6.0	
1 3/4		SFC-28	2-112	35144	155.6	130.2	36.1	11.1	38.1	49.2	58.3	19.1	11.1	107.95		2.72	
		SFC-209	5209														
1 7/8	50	SFC-30	2-114	7889	6 1/8	5 1/8	1 25/64	7/16	1 9/16	2 1/32	2 15/32	3/4	15/32	4.250	7/16	6.5	
1 15/16		SFC-31	2-115	35090	155.6	130.2	35.3	11.1	39.7	51.6	62.7	19.1	11.9	107.95		2.95	
2		SFC-32R	1-2														
		SFC-210	5210														
2	55	SFC-32	2-2														
2 1/8		SFC-34	2-22	9752	6 3/8	5 3/8	1 19/32	7/16	1 9/16	2 3/16	2 23/32	7/8	5/8	4.500	7/16	7.5	
2 3/16		SFC-35	2-23	43377	161.9	136.5	40.5	11.1	39.7	55.6	69.1	22.2	15.9	114.30		3.40	
		SFC-211	5211														
2 1/4	60	SFC-36	2-24	11789	7 1/8	6	1 25/32	1/2	1 11/16	2 9/16	2 63/64	1	7/8	5.000	1/2	10.5	
2 3/8		SFC-38	2-26	52437	181.0	152.4	45.2	12.7	42.9	65.1	75.8	25.4	22.2	127.00		4.76	
2 7/16		SFC-39	2-27	5212													
		SFC-212	5212														
2 11/16	70	SFC-43	2-211	13971	7 5/8	6 1/2	2 5/32	9/16	1 3/4	2 27/32	3 7/16	1 5/32	1 3/32	5.500	1/2	14.5	
		SFC-214	5214	62143	193.7	165.1	54.8	14.3	44.5	72.2	87.3	29.4	27.8	139.70		6.58	
2 7/8	75	SFC-46	2-214	14839	8 3/4	7 1/2	2 9/32	9/16	2	3 1/16	3 41/64	1 5/16	1 1/16	6.375	5/8	18.7	
2 15/16		SFC-47	2-215	66004	222.3	190.5	57.9	14.3	50.8	77.8	92.5	33.3	27.0	161.93		8.48	
		SFC-215	5215														
3 3/16	80	SFC-51	2-33	17412	8 3/4	7 1/2	2 13/32	21/32	2	3 1/4	3 59/64	1 5/16	1 1/4	6.375	5/8	20.0	
		SFC-216	5216	77449	222.3	190.5	61.1	16.7	50.8	82.6	99.6	33.3	31.8	161.93		9.07	

For Standard Duty Bearing Inserts-Single Lock see page G-92.
 *Recommended hole size for pilot +.002" / -.000".

Metric dimensions for reference only.

Performance Mounted Ball Bearings



Mtd. Ball Bearings



- Duty:** Standard
- Rolling Elements:** Ball
- Housing:** Cast Iron Piloted Flange Cartridge
- Self Alignment:** +/- 2 Degrees
- Lock:** SKWEZLOC Locking Collar
- Seal:** Felt
- Optional Seal:** Contact
- Temperature:** -20° to 220°F

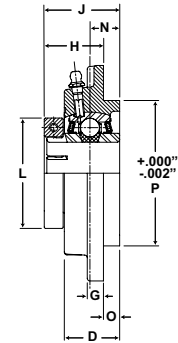
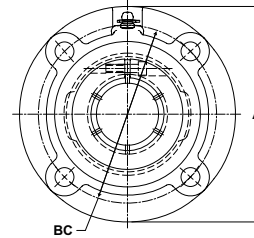

SFC-T Series Standard Duty Piloted Flange Cartridge- SKWEZLOC Locking Collar - Inch

Bore Diameter inch	Part No.	Bearing Insert No.	Basic Dynamic Rating lb/N	Dimensions inch / mm										Bolt Size	Unit Wt. lb/kg
				A	BC	D	G	H	J	L	N	O	P		
1 1/8	SFC-18T	2-12T	4381	4 3/8	3 5/8	1 11/64	3/8	1 3/8	1 5/8	2 3/16	5/8	1/4	3.000	5/16	3.2
1 3/16	SFC-19T	2-13T	19487	111.1	92.1	29.8	9.5	34.9	41.3	55.6	15.9	6.4	76.200		1.45
1 1/4	SFC-20RT	1-14T													
1 1/4	SFC-20T	2-14T	5782 25718	5 127.0	4 1/8 104.8	1 9/32 32.5	3/8 9.5	1 3/8 34.9	1 3/4 44.5	2 7/16 61.9	11/16 17.5	3/8 9.5	3.375 85.725	3/8	4.2 1.91
1 3/8	SFC-22T	2-16T	5782	5	4 1/8	1 9/32	3/8	1 3/8	1 3/4	2 9/16	11/16	3/8	3.375	3/8	4.2
1 7/16	SFC-23T	2-17T	25718	127.0	104.8	32.5	9.5	34.9	44.5	65.1	17.5	9.5	85.725		1.91
1 1/2	SFC-24T	2-18T	7340	5 1/4	4 3/8	1 25/64	7/16	1 9/16	2	2 11/16	3/4	7/16	3.625	3/8	5.0
1 9/16	SFC-25T	2-19T	32648	133.4	111.1	35.3	11.1	39.7	50.8	68.3	19.1	11.1	92.075		2.27
1 5/8	SFC-26T	2-110T	7901 35144	6 1/8 155.6	5 1/8 130.2	1 27/64 36.1	7/16 11.1	1 9/16 39.7	2 50.8	2 13/16 71.4	3/4 19.1	7/16 11.1	4.250 107.950	7/16	6.3 2.86
1 11/16	SFC-27T	2-111T	7901	6 1/8	5 1/8	1 27/64	7/16	1 9/16	2	2 15/16	3/4	7/16	4.250	7/16	6.3
1 3/4	SFC-28T	2-112T	35144	155.6	130.2	36.1	11.1	39.7	50.8	74.6	19.1	11.1	107.950		2.86
1 15/16	SFC-31T	2-115T	7889	6 1/8	5 1/8	1 25/64	7/16	1 5/8	2 3/32	3 3/8	3/4	15/32	4.250	7/16	7.1
2	SFC-32RT	1-2T	35090	155.6	130.2	35.3	11.1	41.3	53.2	85.7	19.1	11.9	107.950		3.22
2	SFC-32T	2-2T	9752 43377	6 3/8 161.9	5 3/8 136.5	1 19/32 40.5	7/16 11.1	1 5/8 41.3	2 1/4 57.2	3 1/2 88.9	7/8 22.2	5/8 15.9	4.500 114.300	7/16	8.1 3.67
2 1/8	SFC-34T	2-22T	9752	6 3/8	5 3/8	1 19/32	7/16	1 5/8	2 1/4	3 5/8	7/8	5/8	4.500	7/16	8.1
2 3/16	SFC-35T	2-23T	43377	161.9	136.5	40.5	11.1	41.3	57.2	92.1	22.2	15.9	114.300		3.67
2 1/4	SFC-36T	2-24T	11789 52437	7 1/8 181.0	6 152.4	1 25/32 45.2	1/2 12.7	1 3/4 44.5	2 5/8 66.7	4 1/16 103.2	1 25.4	7/8 22.2	5.000 127.000	1/2	11.7 5.31
2 3/8	SFC-38T	2-26T	11789	7 1/8	6	1 25/32	1/2	1 3/4	2 5/8	4 1/8	1	7/8	5.000	1/2	11.7
2 7/16	SFC-39T	2-27T	52437	181.0	152.4	45.2	12.7	44.5	66.7	104.8	25.4	22.2	127.000		5.31

SFC-T Series Standard Piloted Flange Cartridge - SKWEZLOC Locking Collar - Metric -SKWEZ™

Bore Diameter mm	Part No.	Bearing Insert No.	Basic Dynamic Rating N/lb	Dimensions mm / inch										Bolt Size	Unit Wt. kg/lb
				A	BC	D	G	H	J	L	N	O	P		
30	SFC-206TMC	5206TMC	19487 4381	111.1 4 3/8	92.1 3 5/8	29.8 1 11/64	9.5 3/8	34.9 1 3/8	41.3 1 5/8	55.6 2 3/16	15.9 .63	6.4 1/4	76.200 3.000	M10	1.45 3.2
35	SFC-207TMC	5207TMC	25718 5782	127.0 5	104.8 4 1/8	32.5 1 9/32	9.5 3/8	34.9 1 3/8	44.5 1 3/4	65.1 2 9/16	17.5 1 1/16	9.5 3/8	85.725 3.375	M12	1.91 4.2
40	SFC-208TMC	5208TMC	32648 7340	133.4 5 1/4	111.1 4 3/8	35.3 1 25/64	11.1 7/16	39.7 1 9/16	50.8 2	68.3 2 11/16	19.1 3/4	11.1 7/16	92.075 3.625	M12	2.27 5
45	SFC-209TMC	5209TMC	35144 7901	155.6 6 1/8	130.2 5 1/8	36.1 1 27/64	11.1 7/16	39.7 1 9/16	50.8 2	74.6 2 15/16	19.1 3/4	11.1 7/16	107.950 4.250	M14	2.86 6.3
50	SFC-210TMC	5210TMC	35090 7889	155.6 6 1/8	130.2 5 1/8	35.3 1 25/64	11.1 7/16	41.3 1 5/8	53.2 2 3/32	85.7 3 3/8	19.1 3/4	11.9 15/32	107.950 4.250	M14	3.22 7.1
55	SFC-211TMC	5211TMC	43377 9752	161.9 6 3/8	136.5 5 3/8	40.5 1 19/32	11.1 7/16	41.3 1 5/8	57.2 2 1/4	92.1 3 5/8	22.2 7/8	15.9 5/8	114.300 4.500	M14	3.67 8.1
60	SFC-212TMC	5212TMC	52437 11789	181.0 7 1/8	152.4 6	45.2 1 25/32	12.7 1/2	44.5 1 3/4	66.7 2 5/8	104.8 4 1/8	25.4 1	22.2 7/8	127.000 5.000	M16	5.31 11.7

For Medium Duty SKWEZLOC Locking Collar Bearing Inserts see page G-93.



- Duty:** Medium
- Rolling Elements:** Ball
- Housing:** Cast Iron Piloted Flange Cartridge
- Self Alignment:** +/- 2 Degrees
- Lock:** Setscrew
- Seal:** Felt
- Optional Seal:** Contact
- Temperature:** -20° to 220°F

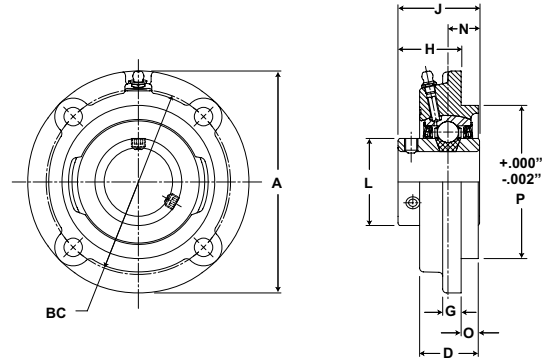

MFC Series Medium Duty Flange Cartridge Units - Setscrew Locking

Bore Diameter		Part No.	Bearing Insert No.	Basic Dynamic Rating lb/N	Dimensions inch / mm										Bolt Size	Unit Wt. lb/kg	
inch	mm				A	BC	D	G	H	J	L	N	O	P*			
15/16		MFC-15	3-015	4381	4 3/8	3 5/8	1 11/64	3/8	1 5/16	1 9/16	1 19/32	5/8	1/4	3.000	5/16	3.0	
1		MFC-16	3-1	19487	111.1	92.1	29.8	9.5	33.3	39.7	40.5	15.9	6.4	76.20			1.36
.984	25	MFC-305	5305														
1 3/16		MFC-19	3-13	5782	5	4 1/8	1 9/32	3/8	1 5/16	1 11/16	1 55/64	11/16	3/8	3.375	3/8	3.9	
1 1/4		MFC-20	2-14	25718	127.0	104.8	32.5	9.5	33.3	42.9	47.2	17.5	9.5	85.73			1.77
1.181	30	MFC-306	5306														
1 7/16		MFC-23	3-17	7340	5 1/4	4 3/8	1 25/64	7/16	1 1/2	1 15/16	2 1/16	3/4	13/32	3.625	3/8	4.7	
1.378	35	MFC-307	5307	32648	133.4	111.1	35.3	11.1	38.1	49.2	52.4	19.1	10.3	92.08			2.13
1 1/2		MFCH-24	3-18	7901	6 1/8	5 1/8	1 27/64	7/16	1 1/2	1 15/16	2 19/64	3/4	13/32	4.250	7/16	6	
	40	MFC-308	5308	35144	155.6	130.2	36.1	11.1	38.1	49.2	58.3	19.1	10.3	107.95			2.72
1 11/16		MFC-27	3-111	7889	6 1/8	5 1/8	1 25/64	7/16	1 9/16	2 1/32	2 15/32	3/4	7/16	4.250	7/16	6.5	
1 3/4		MFC-28	3-112	35090	155.6	130.2	35.3	11.1	39.7	51.6	62.7	19.1	11.1	107.95			2.95
	45	MFC-309	5309														
1 15/16		MFC-31	3-115	9752	6 3/8	5 3/8	1 19/32	7/16	1 9/16	2 3/16	2 23/32	7/8	19/32	4.500	7/16	7.5	
2		MFC-32	2-2	43377	161.9	136.5	40.5	11.1	39.7	55.6	69.1	22.2	15.1	114.30			3.40
	50	MFC-310	5310														
2 3/16		MFC-35	3-23	11789	7 1/8	6	1 25/32	1/2	1 11/16	2 9/16	2 63/64	1	27/32	5.000	1/2	10.5	
2 1/4		MFC-36	2-24	52437	181.0	152.4	45.2	12.7	42.9	65.1	75.8	25.4	21.4	127.00			4.76
	55	MFC-311	5311														
2 7/16		MFC-39	3-27	13971	7 5/8	6 1/2	2 5/32	9/16	1 3/4	2 7/8	3 7/16	1 1/16	1 3/32	5.500	1/2	14.0	
2 1/2		MFC-40	3-28	62143	193.7	165.1	54.8	14.3	44.5	73.0	87.3	27.0	27.8	139.70			6.35
	65	MFC-313	5313														
2 11/16		MFC-43	3-211	14839	8 3/4	7 1/2	2 9/32	9/16	2	3 1/16	3 41/64	1 5/16	1 1/32	6.375	5/8	18.7	
	70	MFC-314	5314	66004	222.3	190.5	57.9	14.3	50.8	77.8	92.5	33.3	26.2	161.93			8.48
2 15/16		MFC-47	3-215	17412	8 3/4	7 1/2	2 13/32	5/8	2	3 1/4	3 59/64	1 5/16	1 7/32	6.375	5/8	20.0	
3		MFC-48	3-3	77449	222.3	190.5	61.1	15.9	50.8	82.6	99.6	33.3	31.0	161.93			9.07
	75	MFC-315	5315														
3 7/16		MFC-55	3-37	21566	10 1/4	8 5/8	2 23/32	3/4	2 21/32	3 25/32	4 25/64	1 9/16	1 3/32	7.375	3/4	32.0	
3 1/2		MFC-56	2-38	95926	260.4	219.1	69.1	19.1	67.5	96.0	111.5	39.7	27.8	187.33			14.51
3 15/16		MFC-63	3-315	29905	10 7/8	9 3/8	3 7/32	7/8	3 1/2	4 5/8	5 11/64	1 15/16	1 3/32	8.125	3/4	44.0	
4		MFC-64	3-4	133017	276.2	238.1	81.8	22.2	88.9	117.5	131.4	49.2	27.8	206.38			19.96
	100	MFC-320	5320														

For Medium Duty Bearing Inserts-Single Lock see page G-95.
 *Recommended hole size for pilot 15/16 to 3 1/2 +.000" / -.002" and 3 15/16 to 4 +.000" / -.004".

Metric dimensions for reference only.
 Not all parts are available from stock. Please contact customer service for availability (800) 626-2120.
 For more information on bearing capabilities outside of our standard offering, please contact Application Engineering (800) 626-2093.



- Duty:** Medium
- Rolling Elements:** Ball
- Housing:** Cast Iron Piloted Flange Cartridge
- Self Alignment:** +/- 2 Degrees
- Lock:** SKWEZLOC Locking Collar
- Seal:** Felt
- Optional Seal:** Contact
- Temperature:** -20° to 220°F

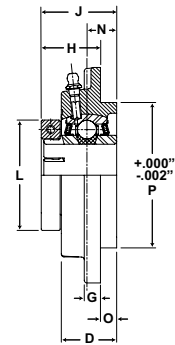
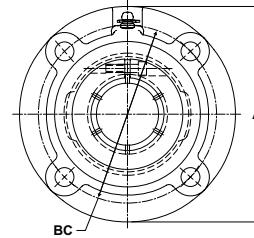

MFC-T Series Medium Duty Flange Cartridge Units - SKWEZLOC Locking Collar

Bore Diameter inch	Part No.	Bearing Insert No.	Basic Dynamic Rating lb/N	Dimensions inch / mm										Bolt Size	Unit Wt. lb/kg
				A	BC	D	G	H	J	L	N	O	P*		
1	MFC-16T	3-1T	4381	4 3/8	3 5/8	1 3/16	3/8	1 3/8	1 5/8	2 1/16	5/8	1/4	3.000	5/16	3.2
			19487	111.1	92.1	30.2	9.5	34.9	41.3	52.4	15.9	6.4	76.20		1.45
1 3/16	MFC-19T	3-13T	5782	5	4 1/8	1 9/32	3/8	1 3/8	1 3/4	2 7/16	11/16	3/8	3.375	3/8	4.2
1 1/4	MFC-20T	2-14T	25718	127.0	104.8	32.5	9.5	34.9	44.5	61.9	17.5	9.5	85.73		1.91
1 7/16	MFC-23T	3-17T	7340	5 1/4	4 3/8	1 25/64	7/16	1 9/16	2	2 11/16	3/4	7/16	3.625	3/8	5.2
1 1/2	MFC-24T	2-18T	32648	133.4	111.1	35.3	11.1	39.7	50.8	68.3	19.1	11.1	92.08		2.36
1 1/2	MFCH-24T	3-18T	7901	6 1/8	5 1/8	1 7/16	7/16	1 9/16	2	2 13/16	3/4	7/16	4.250	7/16	6.3
			35144	155.6	130.2	36.5	11.1	39.7	50.8	71.4	19.1	11.1	107.95		2.86
1 11/16	MFC-27T	3-111T	7889	6 1/8	5 1/8	1 25/64	7/16	1 5/8	2 3/32	3 1/4	3/4	15/32	4.250	7/16	7.1
1 3/4	MFC-28T	3-112T	35090	155.6	130.2	35.3	11.1	41.3	53.2	82.6	19.1	11.9	107.95		3.22
1 15/16	MFC-31T	3-115T	9752	6 3/8	5 3/8	1 5/8	7/16	1 5/8	2 1/4	3 1/2	27/32	5/8	4.500	7/16	8.1
2	MFC-32T	2-2T	43377	161.9	136.5	41.3	11.1	41.3	57.2	88.9	21.4	15.9	114.30		3.67
2 3/16	MFC-35T	3-23T	11789	7 1/8	6	1 25/32	1/2	1 3/4	2 5/8	4 1/16	1	7/8	5.000	1/2	11.7
2 1/4	MFC-36T	2-24T	52437	181.0	152.4	45.2	12.7	44.5	66.7	103.2	25.4	22.2	127.00		5.31

For Medium Duty SKWEZLOC Locking Collar Bearing inserts see page G-96.
 *Recommended hole size for pilot +.000" / -.002".



Duty:	Medium
Rolling Elements:	Ball
Housing:	Cast Iron Piloted Flange Cartridge
Self Alignment:	+/- 2 Degrees
Lock:	Double Setscrew
Seal:	Felt
Optional Seal:	Contact
Temperature:	-20° to 220°F

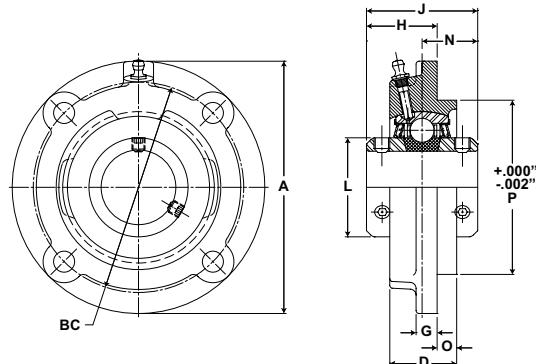

MFCD Series Medium Duty Flange Cartridge Units With Double Lock - Setscrew Locking

Bore Diameter inch	Part No.	Bearing Insert No.	Basic Dynamic Rating lb/N	Dimensions inch / mm										Bolt Size	Unit Wt. lb/kg
				A	BC	D	G	H	J	L	N	O	P*		
1	MFCD-16	3-1	4381 19487	4 3/8 111.1	3 5/8 92.1	1 11/64 29.8	3/8 9.5	1 5/16 33.3	1 3/4 44.5	1 19/32 40.5	11/16 17.5	1/4 6.4	3.000 76.20	5/16	3.8 1.7
1 3/16	MFCD-19	3-13	5782	5	4 1/8	1 9/32	3/8	1 5/16	2	1 55/64	11/16	3/8	3.375	3/8	3.9
1 1/4	MFCD-20	2-14	25718	127.0	104.8	32.5	9.5	33.3	50.8	47.2	17.5	9.5	85.73		1.8
1 7/16	MFCD-23	3-17	7340	5 1/4	4 3/8	1 25/64	7/16	1 1/2	2 5/16	2 1/16	3/4	13/32	3.625	3/8	4.7
1 1/2	MFCD-24	2-18	32648	133.4	111.1	35.3	11.1	38.1	58.7	52.4	19.1	10.3	92.08		2.1
1 11/16	MFCD-27	3-111	7889	6 1/8	5 1/8	1 25/64	7/16	1 9/16	2 1/2	2 15/32	23/32	7/16	4.250	7/16	6.5
1 3/4	MFCD-28	3-112	35090	155.6	130.2	35.3	11.1	39.7	63.5	62.7	18.3	11.1	107.95		3.0
1 15/16	MFCD-31	3-115	9752	6 3/8	5 3/8	1 19/32	7/16	1 9/16	2 5/8	2 23/32	27/32	19/32	4.500	7/16	7.6
2	MFCD-32	2-2	43377	161.9	136.5	40.5	11.1	39.7	66.7	69.1	21.4	15.1	114.30		3.5
2 3/16	MFCD-35	3-23	11789	7 1/8	6	1 25/32	1/2	1 11/16	3 1/8	3 1/8	31/32	27/32	5.000	1/2	10.4
2 1/4	MFCD-36	2-24	52437	181.0	152.4	45.2	12.7	42.9	79.4	79	24.6	21.4	127.00		4.7
2 7/16	MFCD-39	3-27	13971	7 5/8	6 1/2	2 5/32	9/16	1 3/4	3 1/2	3 7/16	1 5/32	1 3/32	5.500	1/2	14.3
2 1/2	MFCD-40	3-28	62143	193.7	165.1	54.8	14.3	44.5	88.9	87.3	29.4	27.8	139.70		6.5
2 11/16	MFCD-43	3-211	14839 66004	8 3/4 222.3	7 1/2 190.5	2 9/32 57.9	9/16 14.3	2 50.8	3 1/2 88.9	3 41/64 92.5	1 9/32 32.5	1 1/32 26.2	6.375 161.93	5/8	18.9 8.6
2 15/16	MFCD-47	3-215	17412	8 3/4	7 1/2	2 13/32	5/8	2	3 7/8	3 59/64	1 15/32	1 7/32	6.375	5/8	20.8
3	MFCD-48	3-3	77449	222.3	190.5	61.1	15.9	50.8	98.4	99.6	37.3	31.0	161.93		9.5
3 7/16	MFCD-55	3-37	21566	10 1/4	8 5/8	2 23/32	3/4	2 21/32	4 7/16	4 25/64	2 7/32	1 3/32	7.375	3/4	32.8
3 1/2	MFCD-56	2-38	95926	260.4	219.1	69.1	19.1	67.5	112.7	111.5	56.4	27.8	187.33		14.9
3 15/16	MFCD-63	3-315	29905	10 7/8	9 3/8	3 7/32	7/8	3 1/2	5 3/8	5 11/64	2 11/16	1 3/32	8.125	3/4	46.0
4	MFCD-64	3-4	133017	276.2	238.1	81.8	22.2	88.9	136.5	131.4	68.3	27.8	206.38		20.9

For Medium Duty Bearing Inserts-Single Lock see page G-95.

*Recommended hole size for pilot 15/16 to 3 1/2 +.000" / -.002" and 3 15/16 to 4 +.000" / -.004".

Metric dimensions for reference only.

Not all parts are available from stock. Please contact customer service for availability (800) 626-2120.

For more information on bearing capabilities outside of our standard offering, please contact Application Engineering (800) 626-2093.



- Duty:** Varies
- Rolling Elements:** Ball
- Housing:** Ductile Iron Hanger Bearing
- Self Alignment:** +/- 2 Degrees
- Lock:** Setscrew
- Seal:** Felt
- Optional Seal:** Contact
- Temperature:** -20° to 220°F

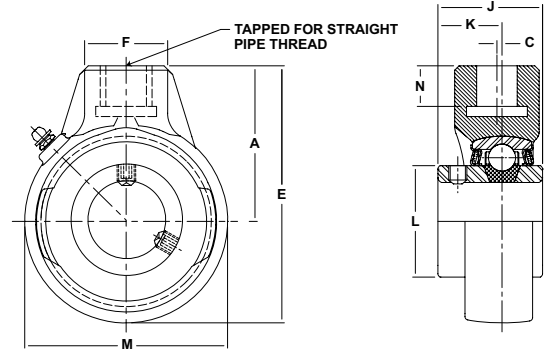

SEHB Series Hanger Bearing External Lube - Setscrew Locking

Bore Diameter		Part No.	Bearing Insert No.	Basic Dynamic Rating lb/N	Dimensions inch / mm								Pipe Tap* N.P.S.M.	N Thread Length	Unit Wt. lb/kg
inch	mm				A	C	E	F	J	K	L	M			
15/16	25	SEHB-15	3-015	4381 19487	2 1/2 63.5	-	4 1/16 103.2	1 9/16 39.7	1 1/2 38.1	7/8 22.2	1 19/32 40.5	3 1/8 79.4	3/4-14	13/16	2.2 1.00
1		SEHB-305	5305												
1 1/16		SEHB-16	3-1												
		SEHB-17	2-11												
	30	SEHB-206	5206												
1 3/16	35	SEHB-19	3-13	5782 25718	2 3/4 69.9	-	4 9/16 115.9	1 9/16 39.7	1 11/16 42.9	1 25.4	1 55/64 47.2	3 5/8 92.1	3/4-14	3/4	3.1 1.41
1 1/4		SEHB-20	2-14												
1 5/16		SEHB-21	2-15												
1 3/8		SEHB-22	2-16												
		SEHB-207	5207												
1 7/16	40	SEHB-23	3-17	7340 32648	2 7/8 73.0	3/32 2.4	4 3/4 120.7	1 9/16 39.7	1 15/16 49.2	1 3/16 30.2	2 1/16 52.4	3 3/4 95.3	3/4-14	3/4	3.4 1.54
1 1/2		SEHB-24	2-18												
1 9/16		SEHB-25	2-19												
		SEHB-208	5208												
1 11/16	50	SEHB-27	3-111	7889 35090	3 1/4 82.6	3/16 4.8	5 7/16 138.1	1 7/8 47.6	2 1/32 51.6	1 9/32 32.5	2 15/32 62.7	4 3/8 111.1	1-11 1/2	13/16	4.5 2.04
1 3/4		SEHB-28	3-112												
1 7/8		SEHB-30	2-114												
1 15/16		SEHB-31	2-115												
2		SEHB-32R	1-2												
	SEHB-210	5210													
2 3/16	60	SEHB-35	3-23	11789 52437	4 101.6	11/32 8.7	6 13/16 173.0	2 5/16 58.7	2 9/16 65.1	1 9/16 39.7	2 63/64 75.8	5 5/8 142.9	1 1/4-11 1/2	1 1/8	9 4.08
2 1/4		SEHB-36	2-24												
2 3/8		SEHB-38	2-26												
2 7/16		SEHB-39	2-27												
		SEHB-212	5212												
2 11/16	75	SEHB-43	3-211	14839 66004	4 5/8 117.5	3/8 9.5	7 7/8 200.0	2 3/4 69.9	3 1/16 77.8	1 3/4 44.5	3 41/64 92.5	6 1/2 165.1	1 1/2-11 1/2	1 1/4	14.6 6.62
2 7/8		SEHB-46	2-214												
2 15/16		SEHB-47	2-215												
		SEHB-215	5215												
3	80	SEHB-48	3-3	17412 77449	4 7/8 123.8	5/16 7.9	8 5/16 211.1	2 13/16 71.4	3 1/4 82.6	1 15/16 49.2	3 59/64 99.6	6 7/8 174.6	1 1/2-11 1/2	1 1/4	16.8 7.62
3 3/16		SEHB-51	2-33												
		SEHB-216	5216												
3 15/16	100	SEHB-63	3-315	29905 133017	8 1/8 206.4		13 1/4 336.6	4 3/8 111.1	4 5/8 117.5	2 11/16 68.3	5 11/64 131.4	10 1/4 260.4	2 1/2-8 1/2	2 5/8	62 28.12
4		SEHB-64	3-4												
		SEHB-320	5320												

For Standard (2-) Duty Bearing Inserts-Double Lock see page G-95. For Medium (3-) Duty Bearing Inserts-Double Lock see page G-97.

*Use Straight Pipe Thread.

Note: Units may be provided with tight internal bearing clearance and housing fits by adding suffix BDZ to Part No., as SEHB-19 BDZ.



Duty:	Varies
Rolling Elements:	Ball
Housing:	Ductile Iron Hanger Bearing
Self Alignment:	+/- 2 Degrees
Lock:	SKWEZLOC Locking Collar
Seal:	Felt
Optional Seal:	Contact
Temperature:	-20° to 220°F

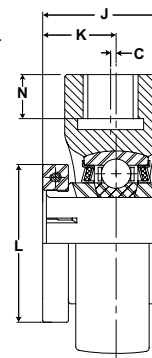
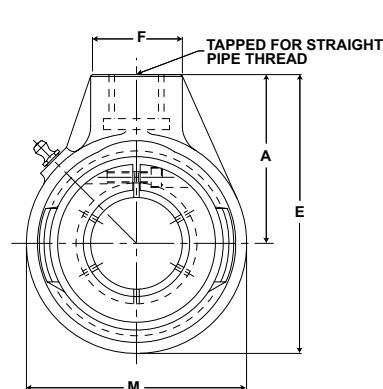

SEHB-T Series Hanger Bearing External Lube - SKWEZLOC Locking Collar

Bore Diameter		Part No.	Bearing Insert No.	Basic Dynamic Rating lb/N	Dimensions inch / mm								Pipe Tap* N.P.S.M.	N Thread Length	Unit Wt. lb/kg
inch	mm				A	C	E	F	J	K	L	M			
15/16 1	25	SEHB-15T	3-015T	4381 19487	2 1/2 63.5	-	4 1/16 103.2	1 9/16 39.7	1 9/16 39.7	7/8 22.2	2 1/16 52.4	3 1/8 79.4	3/4-14	13/16	2.2 1.00
		SEHB-305T	5305T												
		SEHB-16T	3-1T												
		SEHB-17T	2-11T												
1 3/16 1 1/4		SEHB-19T	3-13T	5782 25718	2 3/4 69.9	-	4 9/16 115.9	1 9/16 39.7	1 3/4 44.5	1 1/16 27.0	2 7/16 61.9	3 5/8 92.1	3/4-14	3/4	3.1 1.41
		SEHB-20 T	2-14T												
1 7/16 1 1/2	40	SEHB-23T	3-17T	7340 32648	2 7/8 73.0	3/32 2.4	4 3/4 120.7	1 9/16 39.7	2 50.8	1 1/4 31.8	2 11/16 68.3	3 3/4 95.3	3/4-14	3/4	3.4 1.54
		SEHB-24T	2-18T												
		SEHB-208T	5208T												
1 11/16 1 3/4 1 7/8 1 15/16 2	50	SEHB-27T	3-111T	7889 35090	3 1/4 82.6	3/16 4.8	5 7/16 138.1	1 7/8 47.6	2 3/32 53.2	1 11/32 34.1	3 1/4 82.6	4 3/8 111.1	1-11 1/2	13/16	4.5 2.04
		SEHB-28T	3-112T												
		SEHB-30T	2-114T												
		SEHB-31T	2-115T												
		SEHB-32T	1-2T												
SEHB-210T	5210T														
2 3/16		SEHB-35T	3-23T	11789 52437	4 101.6	11/32 8.7	6 13/16 173.0	2 5/16 58.7	2 5/8 66.7	1 5/8 41.3	4 1/16 103.2	5 5/8 142.9	1 1/4-11 1/2	1 1/8	9 4.08
2 7/16	60	SEHB-39T SEHB-212T	2-27T 5212T	11789 52437	4 101.6	11/32 8.7	6 13/16 173.0	2 5/16 58.7	2 5/8 66.7	1 5/8 41.3	4 1/8 104.8	5 5/8 142.9	1 1/4-11 1/2	1 1/8	9 4.08

For Standard (2-)Duty Bearing Inserts - SKWELOC Locking Collar see page G-94. For Medium (3-) Duty Bearing Inserts - SKWELOC Locking Collar see page G-95.

*Use Straight Pipe Thread.

Note: Units may be provided with tight internal bearing clearance and housing fits by adding suffix BDZ to Part No., as SEHB-19T BDZ.

Metric dimensions for reference only.

Not all parts are available from stock. Please contact customer service for availability (800) 626-2120.

For more information on bearing capabilities outside of our standard offering, please contact Application Engineering (800) 626-2093.



- Duty:** Varies
- Rolling Elements:** Ball
- Housing:** Ductile Iron Hanger Bearing
- Self Alignment:** +/- 2 Degrees
- Lock:** Double Setscrew
- Seal:** Felt
- Optional Seal:** Contact
- Temperature:** -20° to 220°F

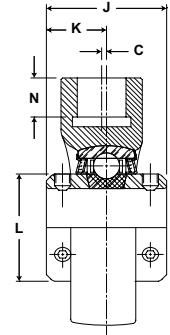
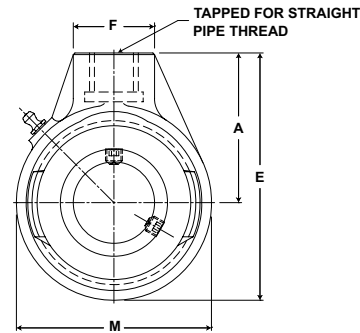

SEHBD Series Hanger Bearing External Lube - Double Set Screw Locking

Bore Diameter inch	Part No.	Bearing Insert No.	Basic Dynamic Rating lb/N	Dimensions inch / mm								Pipe Tap* N.P.S.M.	N Thread Length	Unit Wt. lb/kg
				A	C	E	F	J	K	L	M			
1	SEHBD-16	3-1D	4381	2 1/2	-	4 1/16	1 9/16	1 3/4	7/8	1 19/32	3 1/8	3/4-14	13/16	2.2
			19487	63.5		103.2	39.7	44.5	22.2	40.5	79.4			1.00
1 3/16	SEHBD-19	3-13D	5782	2 3/4	-	4 9/16	1 9/16	2	1	1 55/64	3 5/8	3/4-14	3/4	3.1
1 1/4	SEHBD-20	2-14D	25718	69.9		115.9	39.7	50.8	25.4	47.2	92.1			1.41
1 7/16	SEHBD-23	3-17D	7340	2 7/8	3/32	4 3/4	1 9/16	2 5/16	1 5/32	2 1/16	3 3/4	3/4-14	3/4	3.4
1 1/2	SEHBD-24	2-18D	32648	73.0	2.4	120.7	39.7	58.7	29.4	52.4	95.3			1.54
1 11/16	SEHBD-27	3-111D	7889 35090	3 1/4	3/16	5 7/16	1 7/8	2 1/2	1 1/4	2 15/32	4 3/8	1-11 1/2	13/16	4.5
1 7/8	SEHBD-30	2-114D		82.6	4.8	138.1	47.6	63.5	31.8	62.7	111.1			2.04
1 15/16	SEHBD-31	2-115D												
2 3/16	SEHBD-35	3-23D	11789	3 7/16	1 1/8	5 7/8	1 7/8	3 1/8	1 9/16	2 23/32	4 7/8	1-11 1/2	1 1/8	9
2 7/16	SEHBD-39	2-27D	52437	87.3	28.6	149.2	47.6	79.4	39.7	69.1	123.8			4.08
2 11/16	SEHBD-43	3-211D	13971	4 5/8	3/8	7 7/8	2 3/4	3 1/2	3 1/2	3 41/64	6 1/2	1 1/2-11 1/2	1 1/4	14.6
2 15/16	SEHBD-47	2-215D	62143	117.5	9.5	200.0	69.9	88.9	88.9	92.5	165.1			6.62
3 15/16	SEHBD-63	3-315D	29905	8 1/8	-	13 1/4	4 3/8	5 3/8	5 3/8	5 11/64	10 1/4	2 1/2-8 1/2	2 5/8	62
4	SEHBD-64	3-4D	133017	206.4		336.6	111.1	136.5	136.5	131.4	260.4			28.12

For Standard (2-)Duty Bearing Inserts-Double Lock see page G-94. For Medium (3-) Duty Bearing Inserts-Double Lock see page G-97.

*Use Straight Pipe Thread.

Note: Units may be provided with tight internal and housing fits by adding suffix BDZ to Part No., as SEHBD-19 BDZ.



Duty: Varies
Rolling Elements: Ball
Housing: Ductile Iron Hanger Bearing
Self Alignment: +/- 2 Degrees
Lock: Setscrew
Seal: Felt
Optional Seal: Contact
Temperature: -20° to 220°F

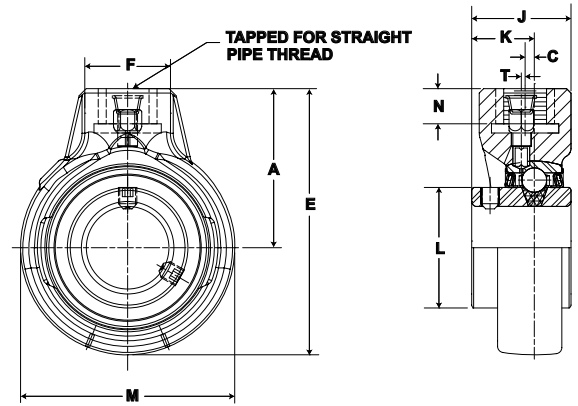

SCHB Series Hanger Bearing Internal Lube - Setscrew Locking

Bore Diameter		Part No.	Bearing Insert No.	Basic Dynamic Rating lb/N	Dimensions inch / mm							Pipe Tap* N.P.S.M.	N Thread Length	T Brg. To Lub. Ftg. Centers	Unit Wt. lb/kg																						
inch	mm				A	C	E	F	J	K	L					M																					
15/16 1 1 1/16	25	SCHB-15	3-015	4381 19487	2 1/2 63.5	-	4 1/16 103.2	1 9/16 39.7	1 1/2 38.1	7/8 22.2	1 19/32 40.5	3 1/8 79.4	3/4 - 14	13/16 0.37	◇ 7/32 0.10	2.2 1.00																					
		SCHB-305	5305														SCHB-16	3-1	SCHB-18	2-12	SCHB-206	5206															
	1 3/16 1 1/4 1 5/16 1 3/8	30	SCHB-19		3-13	5782 25718	2 3/4 69.9	-	4 9/16 115.9	1 9/16 39.7	1 11/16 42.9	1 25.4					1 55/64 47.2	3 5/8 92.1	3/4 - 14	3/4 0.34	◇ 1/4 0.11	3.1 1.41															
			SCHB-20		2-14																		SCHB-21	2-15	SCHB-22	2-16	SCHB-207	5207									
1 7/16 1 1/2 1 9/16	40	SCHB-23	3-17	7340 32648	2 7/8 73.0	3/32 2.4	4 3/4 120.7	1 9/16 39.7	1 15/16 49.2	1 3/16 30.2	2 1/16 52.4	3 3/4 95.3	3/4 - 14	3/4 0.34	◇ 19/64 0.13	3.4 1.54																					
		SCHB-24	2-18														SCHB-25	2-19	SCHB-208	5208																	
		1 11/16 1 3/4 1 7/8 1 15/16 2	50														SCHB-27	3-111	7889 35090	3 1/4 82.6	3/16 4.8	5 7/16 138.1	1 7/8 47.6	2 1/32 51.6	1 9/32 32.5	2 15/32 62.7	4 3/8 111.1	1 - 11 1/2	13/16 0.37	17/64 0.12	4.5 2.04						
SCHB-28	3-112			SCHB-30	2-114	SCHB-31	2-115	SCHB-32R	1-2	SCHB-210	5210																										
2 3/16 2 1/4 2 3/8 2 7/16	60			SCHB-35	3-23	11789 52437	4 101.6	11/32 8.7	6 13/16 173.0	2 5/16 58.7	2 9/16 65.1	1 9/16 39.7	2 63/64 75.8	5 5/8 142.9	1 1/4 - 11 1/2	1 1/8 0.51	21/64 0.15	9.0 4.08																			
				SCHB-36	2-24																											SCHB-38	2-26	SCHB-39	2-27	SCHB-212	5212
				2 11/16 2 7/8 2 15/16	75																											SCHB-43	3-211	14839 66004	4 5/8 117.5	3/8 9.5	7 7/8 200.0
		SCHB-46	2-214																SCHB-47	2-215	SCHB-215	5215															
3 3/16	80	SCHB-51	2-33			17412 77449	4 7/8 123.8	5/16 7.9	8 5/16 211.1	2 13/16 71.4	3 1/4 82.6	1 15/16 49.2	3 59/64 99.6	6 7/8 174.6	1 1/2 - 11 1/2	1 1/4 0.57	13/32 0.18	16.8 7.62																			
		SCHB-216	5216																																		
3 15/16 4	100	SCHB-63	3-315	29905 133017	8 1/8 206.4		13 1/4 336.6	4 3/8 111.1	4 5/8 117.5	2 11/16 68.3	5 11/64 131.4	10 1/4 260.4	2 1/2 - 8 1/2	2 5/8 1.19	19/32 0.27	62 28.12																					
		SCHB-64	3-4														SCHB-320	5320																			

For Standard Duty Bearing inserts-Single Lock see page G-92.

◇ No Adapter or Fitting

*Use Straight Pipe Thread

Metric dimensions for reference only.

Not all parts are available from stock. Please contact customer service for availability (800) 626-2120.

For more information on bearing capabilities outside of our standard offering, please contact Application Engineering (800) 626-2093.



- Duty:** Standard
- Rolling Elements:** Ball
- Housing:** Cast Iron Cylindrical Cartridge
- Self Alignment:** +/- 2 Degrees
- Lock:** Setscrew
- Seal:** Felt
- Optional Seal:** Contact
- Temperature:** -20° to 220°F

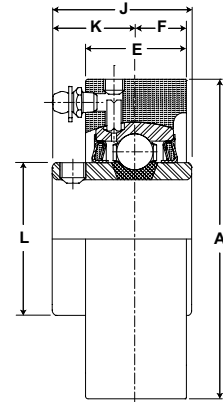

SC Series Standard Duty Cartridge Units - Setscrew Locking

Bore Diameter		Part No.	Bearing Insert No.	Basic Dynamic Rating lb/N	Dimensions inch / mm						Unit Wt. lb/kg	
inch	mm				A ±.001"	E	F	J	L	K		
1/2		SC-8	2-08									
9/16		SC-9	2-09	2611	2.688	7/8	1/2	1 7/32	1 3/16	23/32	1.1	
5/8		SC-10	2-010	11614	68.26	22.2	12.7	31.0	30.2	18.3	0.50	
11/16		SC-11	2-011									
3/4	20	SC-12	2-012	2611	2.938	7/8	1/2	1 7/32	1 3/16	23/32	1.4	
		SC-204	5204	11614	74.61	22.2	12.7	31.0	30.2	18.3	.63	
13/16		SC-13	2-013									
7/8		SC-14	2-014	2801	3.125	1 1/32	9/16	1 3/8	1 3/8	13/16	1.9	
15/16		SC-15	2-015	12459	79.38	26.2	14.3	34.9	34.9	20.6	0.86	
1	25	SC-16	2-1									
		SC-205	5205									
1 1/16		SC-17	2-11									
1 1/8		SC-18	2-12	4381	3.500	1 3/32	5/8	1 1/2	1 19/32	7/8	2.5	
1 3/16		SC-19	2-13	19487	88.90	27.8	15.9	38.1	40.5	22.2	1.13	
1 1/4	30	SC-20R	1-14									
		SC-206	5206									
1 1/4		SC-20	2-14	5782	3.875	1 7/32	11/16	1 11/16	1 55/64	1	3.2	
1 5/16		SC-21	2-15	25718	98.43	31.0	17.5	42.9	47.2	25.4	1.45	
1 3/8		SC-22	2-16									
1 7/16	35	SC-23	2-17									
		SC-207	5207									
1 1/2		SC-24	2-18	7340	4.188	1 15/32	3/4	1 15/16	2 1/16	1 3/16	4.1	
1 9/16	40	SC-25	2-19	32648	106.36	37.3	19.1	49.2	52.4	30.2	1.86	
		SC-208	5208									
1 5/8		SC-26	2-110									
1 11/16		SC-27	2-111	7901	4.375	1 7/16	3/4	1 15/16	2 19/64	1 3/16	4.5	
1 3/4	45	SC-28	2-112	35144	111.13	36.5	19.1	49.2	58.3	30.2	2.04	
		SC-209	5209									
1 13/16		SC-29	2-113									
1 7/8		SC-30	2-114									
1 15/16		SC-31	2-115	7889	4.563	1 15/32	3/4	2 1/32	2 15/32	1 9/32	4.9	
2	50	SC-32R	1-2	35090	115.89	37.3	19.1	51.6	62.7	32.5	2.22	
		SC-210	5210									
2		SC-32	2-2									
2 1/8		SC-34	2-22	9752	4.938	1 19/32	7/8	2 3/16	2 23/32	1 5/16	5.8	
2 3/16	55	SC-35	2-23	43377	125.41	40.5	22.2	55.6	69.1	33.3	2.63	
		SC-211	5211									
2 1/4		SC-36	2-24									
2 3/8		SC-38	2-26	11789	5.875	1 5/8	1	2 9/16	2 63/64	1 9/16	9.0	
2 7/16	60	SC-39	2-27	52437	149.23	41.3	25.4	65.1	75.8	39.7	4.08	
		SC-212	5212									
2 1/2		SC-40	3-28									
2 11/16	70	SC-43	2-211	13971	6.250	2	1 1/16	2 3/4	3 7/16	1 11/16	12.6	
		SC-214	5214	62143	158.75	50.8	27.0	69.9	87.3	42.9	5.72	
2 7/8		SC-46	2-214									
2 15/16	75	SC-47	2-215	14839	6.625	2	1 5/16	3 1/16	3 21/32	1 3/4	13.5	
		SC-215	5215	66004	168.28	50.8	33.3	77.8	92.9	44.5	6.12	

For Standard Duty Bearing Inserts-Single Lock see page G-92.
For Housing fit guidelines see page G-261.

SEALMASTER® Performance Mounted Ball Bearings



Duty:	Standard
Rolling Elements:	Ball
Housing:	Cast Iron Cylindrical Cartridge
Self Alignment:	Consult Application Engineering*
Lock:	SKWEZLOC Locking Collar
Seal:	Felt
Optional Seal:	Contact
Temperature:	-20° to 220°F

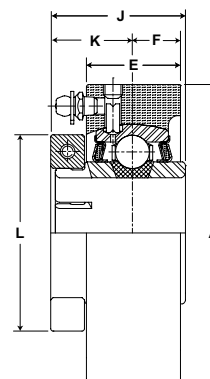

SC-T Series Standard Duty Cartridge Units - SKWEZLOC Locking Collar - Inch

Bore Diameter inch	Part No.	Bearing Insert No.	Basic Dynamic Rating lb/N	Dimensions inch / mm						Unit Wt. lb/kg
				A ±.001"	E	F	J	K	L	
15/16 1	SC-15T* SC-16T*	2-015T 2-1T	2801 12459	3 1/8 79.38	1 1/32 26.2	9/16 14.3	1 7/16 36.5	7/8 22.2	1 15/16 49.2	1.9 .86
1 1/8 1 3/16 1 1/4	SC-18T* SC-19T* SC-20RT*	2-12T 2-13T 1-14T	4381 19487	3 1/2 88.90	1 3/32 27.8	9/16 14.3	1 9/16 39.7	15/16 23.8	2 3/16 55.6	2.5 1.13
1 1/4	SC-20T	2-14T	5782 25718	3 7/8 98.43	1 7/32 31.0	5/8 15.9	1 3/4 44.5	1 1/16 27.0	2 7/16 61.9	3.3 1.47
1 3/8 1 7/16	SC-22T SC-23T	2-16T 2-17T	5782 25718	3 7/8 98.43	1 7/32 31.0	5/8 15.9	1 3/4 44.5	1 1/16 27.0	2 9/16 65.1	3.2 1.45
1 1/2 1 9/16	SC-24T SC-25T	2-18T 2-19T	7340 32648	4 3/16 106.36	1 15/32 37.3	3/4 19.1	2 50.8	1 1/4 31.8	2 11/16 68.3	4.1 1.86
1 5/8	SC-26T	2-110T	7901 35144	4 3/8 111.13	1 7/16 36.5	23/32 18.3	2 50.8	1 1/4 31.8	2 13/16 71.4	4.6 2.09
1 11/16 1 3/4	SC-27T SC-28T	2-111T 2-112T	7901 35144	4 3/8 111.13	1 7/16 36.5	23/32 18.3	2 50.8	1 1/4 31.8	2 15/16 74.6	4.5 2.04
1 15/16	SC-31T	2-115T	7889 35090	4 9/16 115.89	1 15/32 37.3	3/4 19.1	2 3/32 53.2	1 11/32 34.1	3 3/8 85.7	4.9 2.22
2	SC-32T	2-2T	9752 43377	4 15/16 125.41	1 19/32 40.5	27/32 21.4	2 1/4 57.2	1 3/8 34.9	3 1/2 88.9	5.8 2.63
2 1/8 2 3/16	SC-34T SC-35T	2-22T 2-23T	9752 43377	4 15/16 125.41	1 19/32 40.5	27/32 21.4	2 1/4 57.2	1 3/8 34.9	3 5/8 92.1	5.8 2.63
2 1/4	SC-36T	2-24T	11789 52437	5 7/8 149.23	1 5/8 41.3	13/16 20.6	2 5/8 66.7	1 5/8 41.3	4 1/16 103.2	9.0 4.08
2 3/8 2 7/16	SC-38T SC-39T	2-26T 2-27T	11789 52437	5 7/8 149.23	1 5/8 41.3	13/16 20.6	2 5/8 66.7	1 5/8 41.3	4 1/8 104.8	9.0 4.08

SC-T Series Standard Cartridge Units - SKWEZLOC Locking Collar - Metric - SKWEZ™

Bore Diameter mm	Part No.	Bearing Insert No.	Basic Dynamic Rating lb/N	Dimensions mm / inch						Unit Wt. lb/kg
				A ±.0025 mm	E	F	J	K	L	
25	SC-205TMC*	5205TMC	12459 2801	79.38 3 1/8	26.2 1 1/32	14.3 9/16	36.5 1 7/16	22.2 7/8	49.2 1 15/16	.86 1.9
30	SC-206TMC*	5206TMC	19487 4381	88.90 3 1/2	27.8 1 3/32	14.3 9/16	39.7 1 9/16	23.8 15/16	55.6 2 3/16	1.13 2.5
35	SC-207TMC	5207TMC	25718 5782	98.43 3 7/8	31.0 1 7/32	15.9 5/8	44.5 1 3/4	27.0 1 1/16	65.1 2 9/16	1.45 3.2
40	SC-208TMC	5208TMC	32648 7340	106.36 4 3/16	37.3 1 15/32	19.1 3/4	50.8 2	31.8 1 1/4	68.3 2 11/16	1.86 4.1
45	SC-209TMC	5209TMC	35144 7901	111.13 4 3/8	36.5 1 7/16	18.3 23/32	50.8 2	31.8 1 1/4	74.6 2 15/16	2.04 4.5
50	SC-210TMC	5210TMC	35090 7889	115.89 4 9/16	37.3 1 15/32	19.1 3/4	53.2 2 3/32	34.1 1 11/32	85.7 3 3/8	2.22 4.9
55	SC-211TMC	5211TMC	43377 9752	125.41 4 15/16	40.5 1 19/32	21.4 27/32	57.2 2 1/4	34.9 1 3/8	92.1 3 5/8	2.63 5.8
60	SC-212TMC	5212TMC	52437 11789	149.23 5 7/8	41.3 1 5/8	20.6 13/16	66.7 2 5/8	41.3 1 5/8	104.8 4 1/8	4.08 9.0

*Reversed Inner Ring; Misalignment Capability $\pm 1 1/2^\circ$
 For standard Duty SKWEZLOC Bearing inserts see page G-93.
 For Housing fit guidelines see page G-261.

Metric dimensions for reference only.

Bearing Selection
Page G-3

Nomenclature Aid
Page G-18

Features & Benefits
Page G-21

Product Options
Page G-23

Technical Engineering
Page G-220



- Duty:** Medium
- Rolling Elements:** Ball
- Housing:** Cast Iron Cylindrical Cartridge
- Self Alignment:** +/- 2 Degrees
- Lock:** Setscrew
- Seal:** Felt
- Optional Seal:** Contact
- Temperature:** -20° to 220°F

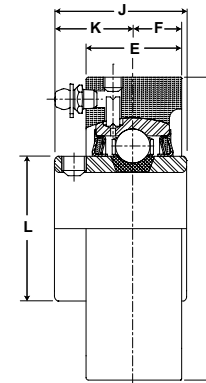

MSC Series Medium Duty Cartridge Units - Setscrew Locking

Bore Diameter		Part No.	Bearing Insert No.	Basic Dynamic Rating lb/N	Dimensions inch / mm						Unit Wt. lb/kg
inch	mm				A	E	F	J	K	L	
					±.001"						
15/16 1	25	MSC-15	3-015	4381	3.500	1 3/32	9/16	1 1/2	7/8	1 19/32	2.5
		MSC-16	3-1	19487	88.90	27.8	14.3	38.1	22.2	40.5	1.13
		MSC-305	5305								
1 3/16 1 1/4	30	MSC-19	3-13	5782	3.875	1 7/32	5/8	1 11/16	1	1 55/64	3.2
		MSC-20	2-14	25718	98.43	31.0	15.9	42.9	25.4	47.2	1.45
		MSC-306	5306								
1 3/8 1 7/16	35	MSC-22	3-16	7340	4.188	1 15/32	3/4	1 15/16	1 3/16	2 1/16	4.1
		MSC-23	3-17	32648	106.36	37.3	19.1	49.2	30.2	52.4	1.86
		MSC-307	5307								
1 1/2	40	MSC-24	3-18	7901	4.375	1 7/16	23/32	1 15/16	1 3/16	2 19/64	4.5
		MSC-308	5308	35144	111.13	36.5	18.3	49.2	30.2	58.3	2.04
1 11/16 1 3/4	45	MSC-27	3-111	7889	4.563	1 15/32	3/4	2 1/32	1 9/32	2 15/32	4.9
		MSC-28	3-112	35090	115.89	37.3	19.1	51.6	32.5	62.7	2.22
		MSC-309	5309								
1 15/16 2	50	MSC-31	3-115	9752	4.938	1 19/32	51/64	2 3/16	1 5/16	2 23/32	5.8
		MSC-32	2-2	43377	125.41	40.5	20.2	55.6	33.3	69.1	2.63
		MSC-310	5310								
2 3/16 2 1/4	55	MSC-35	3-23	11789	5.875	1 5/8	13/16	2 9/16	1 9/16	2 63/64	9.5
		MSC-36	2-24	52437	149.23	41.3	20.6	65.1	39.7	75.8	4.31
		MSC-311	5311								
2 7/16 2 1/2	65	MSC-39	3-27	13971	6.250	2	1	2 3/4	1 11/16	3 7/16	12.6
		MSC-40	3-28	62143	158.75	50.8	25.4	69.9	42.9	87.3	5.72
		MSC-313	5313								
2 11/16 2 3/4	70	MSC-43	3-211	14839	6.625	2	1	3 1/16	1 3/4	3 21/32	14.1
		MSC-44	3-212	66004	168.28	50.8	25.4	77.8	44.5	92.9	6.40
		MSC-314	5314								
2 15/16 3	75	MSC-47	3-215	17412	7.000	2 3/16	1 3/32	3 1/4	1 15/16	3 59/64	16.6
		MSC-48	3-3	77449	177.80	55.6	27.8	82.6	49.2	99.6	7.53
		MSC-315	5315								
3 3/16 3 1/4 3 3/8	80	MSC-51	3-33	18681	7.438	2 1/2	1 1/4	3 3/8	2 1/32	4 5/32	20.2
		MSC-52	2-34	83093	188.91	63.5	31.8	85.7	51.6	105.6	9.16
		MSC-54	2-36								
		MSC-316	5316								
3 7/16 3 1/2		MSC-55	3-37	21566	8.188	2 1/2	1 1/4	3 25/32	2 7/32	4 25/64	25.8
		MSC-56	2-38	95926	207.96	63.5	31.8	96.0	56.4	111.5	11.70
3 15/16 4	100	MSC-63	3-315	29905	9.500	3	1 1/2	4 5/8	2 11/16	5 11/64	42
		MSC-64	3-4	133017	241.30	76.2	38.1	117.5	68.3	131.4	19.05
		MSC-320	5320								

For Medium Duty Bearing Inserts-Single Lock see page G-95.
For Housing fit guidelines see page G-261.

SEALMASTER® Performance Mounted Ball Bearings



Duty:	Medium
Rolling Elements:	Ball
Housing:	Cast Iron Cylindrical Cartridge
Self Alignment:	Consult Application Engineering*
Lock:	SKWEZLOC Locking Collar
Seal:	Felt
Optional Seal:	Contact
Temperature:	-20° to 220°F

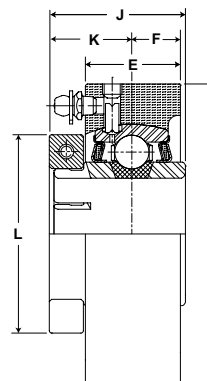

MSC-T Series Medium Duty Cartridge Units- SKWEZLOC Locking Collar

Bore Diameter inch	Part No.	Bearing Insert No.	Basic Dynamic Rating lb/N	Dimensions inch / mm						Unit Wt. lb/kg
				A	E	J	K	F	L	
1	MSC-16T	3-1T	4381	3 1/2	1 3/32	1 9/16	15/16	9/16	2 1/16	2.5
			19487	88.90	27.8	39.7	23.8	14.3	52.4	1.13
1 3/16	MSC-19T	3-13T	5782	3 7/8	1 7/32	1 3/4	1 1/16	5/8	2 7/16	3.2
1 1/4	MSC-20T	2-14T	25718	98.43	31.0	44.5	27.0	15.9	61.9	1.45
1 7/16	MSC-23T	3-17T	7340	4 3/16	1 15/32	2	1 1/4	3/4	2 11/16	4.1
			32648	106.36	37.3	50.8	31.8	19.1	68.3	1.86
1 1/2	MSC-24T	3-18T	7901	4 3/8	1 7/16	2	1 1/4	23/32	2 13/16	4.5
			35144	111.13	36.5	50.8	31.8	18.3	71.4	2.04
1 11/16	MSC-27T	3-111T	7889	4 9/16	1 15/32	2 3/32	1 11/32	3/4	3 1/4	4.9
1 3/4	MSC-28T	3-112T	35090	115.89	37.3	53.2	34.1	19.1	82.6	2.22
1 15/16	MSC-31T	3-115T	9752	4 15/16	1 19/32	2 1/4	1 3/8	27/32	3 1/2	5.8
2	MSC-32T	2-2T	43377	125.41	40.5	57.2	34.9	21.4	88.9	2.63
2 3/16	MSC-35T	3-23T	11789	5 7/8	1 5/8	2 5/8	1 5/8	13/16	4 1/16	9.0
2 1/4	MSC-36T	2-24T	52437	149.23	41.3	66.7	41.3	20.6	103.2	4.08

* Misalignment capability reduced as a result of SKWEZLOC collar clearance.
For Medium Duty SKWEZLOC Locking Collar Bearing inserts see page G-96.
For Housing fit guidelines see page G-261.

Metric dimensions for reference only.

Not all parts are available from stock. Please contact customer service for availability (800) 626-2120.

For more information on bearing capabilities outside of our standard offering, please contact Application Engineering (800) 626-2093.



- Duty:** Standard
- Rolling Elements:** Ball
- Housing:** Cast Iron Wide Slot Take Up
- Self Alignment:** +/- 2 Degrees
- Lock:** SKWEZLOC Locking Collar
- Seal:** Felt
- Optional Seal:** Contact
- Temperature:** -20° to 220°F

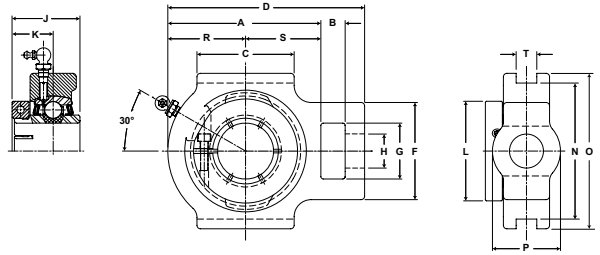

ST-T Series Standard Duty Take-Up Units - SKWEZLOC Locking Collar

Bore Diameter inch	Part No.	Bearing Insert No.	Basic Dynamic Rating lb/N	Dimensions inch / mm																	Unit Wt. lb/kg
				A	B	C	D	F	G	H		J	K	L	N	O	P				
										Core	Hub						R	S	T		
3/4	ST-12T	2-012T	2611 11614	2 11/16 68.3	5/8 15.9	2 50.8	3 11/16 93.7	2 50.8	1 1/4 31.8	3/4 19.1	1 9/32 32.5	25/32 19.8	1 3/4 44.5	3 76.2	3 1/2 88.9	1 3/8 34.9	1 5/16 33.3	1 3/8 34.9	17/32	2.2 1.00	
15/16 1	ST-15T ST-16T	2-015T 2-1T	2801 12459	2 13/16 71.4	5/8 15.9	2 50.8	3 13/16 96.8	2 50.8	1 1/4 31.8	3/4 19.1	1 7/16 36.5	7/8 22.2	1 15/16 49.2	3 76.2	3 1/2 88.9	1 1/2 38.1	1 3/8 34.9	1 7/16 36.5	17/32	2.8 1.27	
1 1/8 1 3/16	ST-18T ST-19T	2-12T 2-13T	4381 19487	3 7/16 87.3	5/8 15.9	2 1/4 57.2	4 7/16 112.7	2 3/16 55.6	1 7/16 36.5	7/8 22.2	1 9/16 39.7	15/16 23.8	2 3/16 55.6	3 1/2 88.9	4 101.6	1 3/4 44.5	1 11/16 42.9	1 3/4 44.5	17/32	3.6 1.63	
1 1/4	ST-20T	2-14T	5782 25718	3 15/16 100.0	5/8 15.9	2 1/2 63.5	5 1/16 128.6	2 1/2 63.5	1 7/16 36.5	7/8 22.2	1 3/4 44.5	1 1/16 27.0	2 7/16 61.9	3 1/2 88.9	4 101.6	1 3/4 44.5	2 50.8	1 15/16 49.2	17/32	4.3 1.95	
1 3/8 1 7/16	ST-22T ST-23T	2-16T 2-17T	5782 25718	3 15/16 100.0	5/8 15.9	2 1/2 63.5	5 1/16 128.6	2 1/2 63.5	1 7/16 36.5	7/8 22.2	1 3/4 44.5	1 1/16 27.0	2 9/16 65.1	3 1/2 88.9	4 101.6	1 3/4 44.5	2 50.8	1 15/16 49.2	17/32	4.3 1.95	
1 1/2 1 9/16	ST-24T ST-25T	2-18T 2-19T	7340 32648	4 5/16 109.5	3/4 19.1	3 1/4 82.6	5 11/16 144.5	3 1/4 82.6	1 15/16 49.2	1 1/8 28.6	2 50.8	1 1/4 31.8	2 11/16 68.3	4 101.6	4 1/2 114.3	2 1/8 54.0	2 3/16 55.6	2 1/8 54.0	11/16	6.3 2.86	
1 5/8	ST-26T	2-110T	7901 35144	4 5/16 109.5	3/4 19.1	3 1/4 82.6	5 11/16 144.5	3 1/4 82.6	1 15/16 49.2	1 1/8 28.6	2 50.8	1 1/4 31.8	2 13/16 71.4	4 101.6	4 5/8 117.5	2 3/16 55.6	2 1/4 57.2	2 1/16 52.4	11/16	6.3 2.86	
1 11/16 1 3/4	ST-27T ST-28T	2-111T 2-112T	7901 35144	4 5/16 109.5	3/4 19.1	3 1/4 82.6	5 11/16 144.5	3 1/4 82.6	1 15/16 49.2	1 1/8 28.6	2 50.8	1 11/32 34.1	2 15/16 74.6	4 101.6	4 5/8 117.5	2 3/16 55.6	2 1/4 57.2	2 1/16 52.4	11/16	6.3 2.86	
1 15/16 2	ST-31T ST-32RT	2-115T 1-2T	7889 35090	4 1/2 114.3	3/4 19.1	3 3/8 85.7	5 7/8 149.2	3 1/4 82.6	1 15/16 49.2	1 1/8 28.6	2 3/32 53.2	1 1/4 31.8	3 3/8 85.7	4 101.6	4 5/8 117.5	2 3/16 55.6	2 5/16 58.7	2 3/16 55.6	11/16	6.6 2.99	
2	ST-32T	2-2T	9752 43377	5 127.0	1 25.4	3 3/4 95.3	6 3/4 171.5	4 101.6	2 1/2 63.5	1 3/8 34.9	2 1/4 57.2	1 3/8 34.9	3 1/2 88.9	5 1/8 130.2	5 3/4 146.1	2 1/4 57.2	2 9/16 65.1	2 7/16 61.9	1 1/16	10.4 4.72	
2 1/8 2 3/16	ST-34T ST-35T	2-22T 2-23T	9752 43377	5 127.0	1 25.4	3 3/4 95.3	6 3/4 171.5	4 101.6	2 1/2 63.5	1 3/8 34.9	2 1/4 57.2	1 3/8 34.9	3 5/8 92.1	5 1/8 130.2	5 3/4 146.1	2 1/4 57.2	2 9/16 65.1	2 7/16 61.9	1 1/16	10.4 4.72	
2 1/4	ST-36T	2-24T	11789 52437	5 5/8 142.9	1 1/4 31.8	4 101.6	7 5/8 193.7	4 101.6	2 1/2 63.5	1 3/8 34.9	2 5/8 66.7	1 5/8 41.3	4 1/16 103.2	5 1/8 130.2	5 3/4 146.1	2 3/8 60.3	2 15/16 74.6	2 11/16 68.3	1 1/16	13.4 6.08	
2 3/8 2 7/16	ST-38T ST-39T	2-26T 2-27T	11789 52437	5 5/8 142.9	1 1/4 31.8	4 101.6	7 5/8 193.7	4 101.6	2 1/2 63.5	1 3/8 34.9	2 5/8 66.7	1 5/8 41.3	4 1/8 104.8	5 1/8 130.2	5 3/4 146.1	2 3/8 60.3	2 15/16 74.6	2 11/16 68.3	1 1/16	13.4 6.08	

For Standard Duty Bearing Inserts - SKWEZLOC Locking Collar see page G-93
 For Take-Up Frames see pages G-76 to G-78.

Metric dimensions for reference only.
 Not all parts are available from stock. Please contact customer service for availability (800) 626-2120.
 For more information on bearing capabilities outside of our standard offering, please contact Application Engineering (800) 626-2093.



- Duty:** Medium
- Rolling Elements:** Ball
- Housing:** Cast Iron Wide Slot Take Up
- Self Alignment:** +/- 2 Degrees
- Lock:** Setscrew
- Seal:** Felt
- Optional Seal:** Contact
- Temperature:** -20° to 220°F

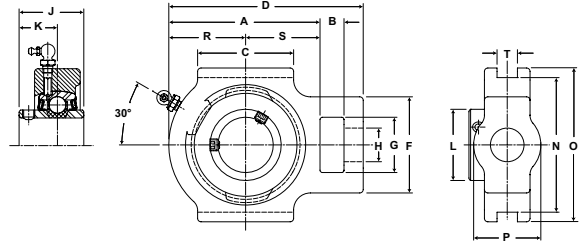

MST Series Medium Duty Take-Up Units - Setscrew Locking

Bore Diameter inch mm		Part No.	Bearing Insert No.	Basic Dynamic Rating lb/N	Dimensions inch / mm																Unit Wt. lb/kg
					A	B	C	D	F	G	H Core	J	K	N	O	P Hub	R	S	T		
1 15/16	25	MST-15	3-015	4381	3 7/16	5/8	2 1/4	4 7/16	2	1 7/16	7/8	1 1/2	7/8	3 1/2	4	1 3/4	1	1 3/4	17/32	3.4	
		MST-16	3-1	19487	87.3	15.9	57.2	112.7	3/16	36.5	22.2	38.1	22.2	88.9	101.6	44.5	1 11/16	44.5	17/32	1.54	
		MST-305	5305						55.6								42.9				
1 3/16 1 1/4	30	MST-19	3-13	5782	3 15/16	5/8	2 1/2	5 1/16	2 1/2	1 7/16	7/8	1 11/16	1	3 1/2	4	1 3/4	2	1 15/16	17/32	4.0	
		MST-20	2-14	25718	100.0	15.9	63.5	128.6	63.5	36.5	22.2	42.9	25.4	88.9	101.6	44.5	50.8	49.2	17/32	1.81	
		MST-306	5306																		
1 7/16	35	MST-23	3-17	7340	4 5/16	3/4	3 1/4	5 11/16	3 1/4	1 15/16	1 1/8	1 15/16	1 3/16	4	4 1/2	2 1/8	2 3/16	2 1/8	11/16	6.2	
		MST-307	5307	32648	109.5	19.1	82.6	144.5	82.6	49.2	28.6	49.2	30.2	101.6	114.3	54.0	55.6	54.0	11/16	2.81	
1 1/2	40	MST-24	3-18	7901	4 5/16	3/4	3 1/4	5 11/16	3 1/4	1 15/16	1 1/8	1 15/16	1 3/16	4	4 5/8	2 3/16	2 1/4	2 1/16	11/16	6.2	
		MST-308	5308	35144	109.5	19.1	82.6	144.5	82.6	49.2	28.6	49.2	30.2	101.6	117.5	55.6	57.2	52.4	11/16	2.81	
1 11/16 1 3/4	45	MST-27	3-111	7889	4 1/2	3/4	3 3/8	5 7/8	3 1/4	1 15/16	1 1/8	2 1/32	1 9/32	4	4 5/8	2 3/16	2 5/16	2 3/16	11/16	6.4	
		MST-28	3-112	35090	114.3	19.1	85.7	149.2	82.6	49.2	28.6	51.6	32.5	101.6	117.5	55.6	58.7	55.6	11/16	2.90	
		MST-309	5309																		
1 15/16 2	50	MST-31	3-115	9752	5	1	3 3/4	6 3/4	4	2 1/2	1 3/8	2 3/16	1 5/16	5 1/8	5 3/4	2 1/4	2 9/16	2 7/16	11/16	10.0	
		MST-32	2-2	43377	127.0	25.4	95.3	171.5	101.6	63.5	34.9	55.6	33.3	130.2	146.1	57.2	65.1	61.9	11/16	4.54	
		MST-310	5310																		
2 3/16 2 1/4	55	MST-35	3-23	11789	5 5/8	1 1/4	4	7 5/8	4	2 1/2	1 3/8	2 9/16	1 9/16	5 1/8	5 3/4	2 3/8	2 15/16	2 11/16	1 1/16	12.3	
		MST-36	2-24	52437	142.9	31.8	101.6	193.7	101.6	63.5	34.9	65.1	39.7	130.2	146.1	60.3	74.6	68.3	1 1/16	5.58	
		MST-311	5311																		
2 7/16 2 1/2	65	MST-39	3-27	13971	6 3/4	1 1/4	4 3/4	8 13/16	4 3/8	2 3/4	1 5/8	2 3/4	1 11/16	5 15/16	6 9/16	3 3/8	3 7/16	3 5/16	1 1/16	19.5	
		MST-40	3-28	62143	171.5	31.8	120.7	223.8	111.1	69.9	41.3	69.9	42.9	150.8	166.7	85.7	87.3	84.1	1 1/16	8.85	
		MST-313	5313																		
2 11/16	70	MST-43	3-211	14839	7 1/16	1 1/4	4 3/4	9 1/8	4 3/8	2 3/4	1 5/8	3 1/16	1 3/4	5 15/16	6 9/16	3 3/8	3 5/8	3 7/16	1 1/16	19.8	
		MST-314	5314	66004	179.4	31.8	120.7	231.8	111.1	69.9	41.3	77.8	44.5	150.8	166.7	85.7	92.1	87.3	1 1/16	8.98	
2 15/16 3	75	MST-47	3-215	17412	7 3/16	1 1/4	4 3/4	9 1/4	4 3/8	2 3/4	1 5/8	3 1/4	1 15/16	6 1/2	7 1/4	3 3/8	3 3/4	3 7/16	1 1/16	23.0	
		MST-48	3-3	77449	182.6	31.8	120.7	235.0	111.1	69.9	41.3	82.6	49.2	165.1	184.2	85.7	95.3	87.3	1 1/16	10.43	
		MST-315	5315																		
3 3/16 3 1/4	80	MST-51	3-33	18681	7 5/8	1 1/2	6 3/16	10 1/4	4 7/8	2 7/8	1 7/8	3 3/8	2 1/32	6 13/16	7 13/16	3 1/2	3 7/8	3 3/4	1 13/16	31.8	
		MST-52	2-34	83093	193.7	38.1	157.2	260.4	123.8	73.0	47.6	85.7	51.6	173.0	198.4	88.9	98.4	95.3	1 13/16	14.42	
		MST-316	5316																		
3 15/16 4	100	MST-63	3-315	29905	9 1/4	1 1/2	6 1/2	11 7/8	4 7/8	2 7/8	1 7/8	4 5/8	2 11/16	8 3/8	9 3/8	3 1/2	4 3/4	4 1/2	1 13/16	50.0	
		MST-64	3-4	133017	235.0	38.1	165.1	301.6	123.8	73.0	47.6	117.5	68.3	212.7	238.1	88.9	120.7	114.3	1 13/16	22.68	
		MST-320	5320																		

For Medium Duty Bearing Inserts-Single Lock see page G-95.
For Take-Up Frames see page G-78.



Duty: Medium
Rolling Elements: Ball
Housing: Cast Iron Wide Slot Take Up
Self Alignment: +/- 2 Degrees
Lock: SKWEZLOC Locking Collar
Seal: Felt
Optional Seal: Contact
Temperature: -20° to 220°F

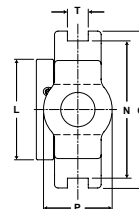
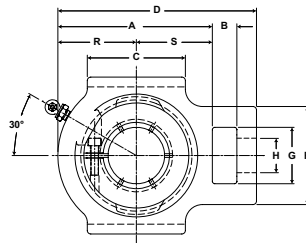
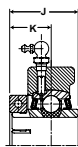

MST-T Series Medium Duty Take-Up Units - SKWEZLOC Locking Collar

Bore Diameter inch	Part No.	Bearing Insert No.	Basic Dynamic Rating lb/N	Dimensions inch / mm																Unit Wt. lb/kg
				A	B	C	D	F	G	H Core	J	K	L	N	O	P Hub	R	S	T	
1	MST-16T	3-1T	4381 19487	3 7/16 87.3	5/8 15.9	2 1/4 57.2	4 7/16 112.7	2 3/16 55.6	1 7/16 36.5	7/8 22.2	1 9/16 39.7	15/16 23.8	2 1/16 52.4	3 1/2 88.9	4 101.6	1 3/4 44.5	1 11/16 42.9	1 3/4 44.5	17/32	3.6 1.63
1 3/16 1 1/4	MST-19T MST-20T	3-13T 2-14T	5782 25718	3 15/16 100.0	5/8 15.9	2 1/2 63.5	5 1/16 128.6	2 1/2 63.5	1 7/16 36.5	7/8 22.2	1 3/4 44.5	1 1/16 27.0	2 7/16 61.9	3 1/2 88.9	4 101.6	1 3/4 44.5	2 50.8	1 15/16 49.2	17/32	4.3 1.95
1 7/16	MST-23T	3-17T	7340 32648	4 5/16 109.5	3/4 19.1	3 1/4 82.6	5 11/16 144.5	3 1/4 82.6	1 15/16 49.2	1 1/8 28.6	2 50.8	1 1/4 31.8	2 11/16 68.3	4 101.6	4 1/2 114.3	2 1/8 54.0	2 3/16 55.6	2 1/8 54.0	11/16	6.3 2.86
1 1/2	MST-24T	3-18T	7901 35144	4 5/16 109.5	3/4 19.1	3 1/4 82.6	5 11/16 144.5	3 1/4 82.6	1 15/16 49.2	1 1/8 28.6	2 50.8	1 1/4 31.8	2 13/16 71.4	4 101.6	4 5/8 117.5	2 3/16 55.6	2 1/4 57.2	2 1/16 52.4	11/16	6.3 2.86
1 11/16 1 3/4	MST-27T MST-28T	3-111T 3-112T	7889 35090	4 1/2 114.3	3/4 19.1	3 3/8 85.7	5 7/8 149.2	3 1/4 82.6	1 15/16 49.2	1 1/8 28.6	2 3/32 53.2	1 11/32 34.1	3 1/4 82.6	4 101.6	4 5/8 117.5	2 3/16 55.6	2 5/16 58.7	2 3/16 55.6	11/16	6.6 2.99
1 15/16 2	MST-31T MST-32T	3-115T 2-2T	9752 43377	5 127.0	1 25.4	3 3/4 95.3	6 3/4 171.5	4 101.6	2 1/2 63.5	1 3/8 34.9	2 1/4 57.2	1 3/8 34.9	3 1/2 88.9	5 1/8 130.2	5 3/4 146.1	2 1/4 57.2	2 9/16 65.1	2 7/16 61.9	1 1/16	10.4 4.72
2 3/16 2 1/4	MST-35T MST-36T	3-23T 2-24T	11789 52437	5 5/8 142.9	1 1/4 31.8	4 101.6	7 5/8 193.7	4 101.6	2 1/2 63.5	1 3/8 34.9	2 5/8 66.7	1 5/8 41.3	4 1/16 103.2	5 1/8 130.2	5 3/4 146.1	2 3/8 60.3	2 15/16 74.6	2 11/16 68.3	1 1/16	13.4 6.08

For medium duty SKWEZLOC Locking Collar Bearing Inserts see page G-96.

For Take-Up Frames see page G-80.

Metric dimensions for reference only.

Not all parts are available from stock. Please contact customer service for availability (800) 626-2120.

For more information on bearing capabilities outside of our standard offering, please contact Application Engineering (800) 626-2093.



- Duty:** Standard
- Rolling Elements:** Ball
- Housing:** Center Pull Take Up Frame & Take Up Housing
- Self Alignment:** +/- 2 Degrees
- Lock:** Setscrew
- Optional Lock:** SKWEZLOC Locking Collar
- Seal:** Felt
- Optional Seal:** Contact
- Temperature:** -20° to 220°F

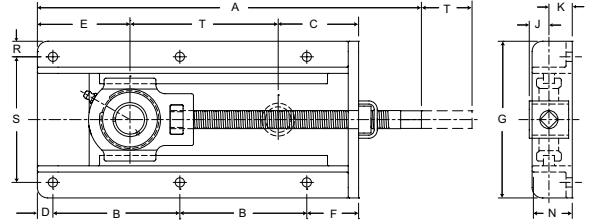

STH Center Pull Take Up Frames

Bore Diameter		Part No.	Housing Assembly Included	Bearing Insert No.	Dimensions inch / mm											Bolt Size	Unit Wt. lb/kg	Frame Only Part No.		
inch	mm				T Travel	A	B	C	D	E	F	G	J	K	N				R	S
7/8		STH-14-6	ST-14	2-014	6	15	4 5/8	3 1/4	3/4	3 1/4	2 1/2	7 9/16	13/16	1 1/8	1 3/4	3/4	6 1/16	3/8	11.6	STH 12 TO 16-6 DZU
		152.4			381.0	117.5	82.6												19.1	
		STH-14-9			9	18	6 1/8												13.6	STH 12 TO 16-9 DZU
					228.6	457.2	155.6												6.2	
15/16		STH-15-6	ST-15	2-015	6	15	4 5/8	3 1/4	3/4	3 1/4	2 1/2	7 9/16	13/16	1 1/8	1 3/4	3/4	6 1/16	3/8	11.6	STH 12 TO 16-6 DZU
		152.4			381.0	117.5	82.6												19.1	
		STH-15-9			9	18	6 1/8												13.6	STH 12 TO 16-9 DZU
					228.6	457.2	155.6												6.2	
	25	STH-205-6	ST-205	5205	6	15	4 5/8	3 1/4	3/4	3 1/4	2 1/2	7 9/16	13/16	1 1/8	1 3/4	3/4	6 1/16	3/8	11.6	STH 12 TO 16-6 DZU
		152.4			381.0	117.5	82.6												19.1	
		STH-205-9			9	18	6 1/8												13.6	STH 12 TO 16-9 DZU
					228.6	457.2	155.6												6.2	
1		STH-16-6	ST-16	2-1	6	15	4 5/8	3 1/4	3/4	3 1/4	2 1/2	7 9/16	13/16	1 1/8	1 3/4	3/4	6 1/16	3/8	11.6	STH 12 TO 16-6 DZU
		152.4			381.0	117.5	82.6												19.1	
		STH-16-9			9	18	6 1/8												13.6	STH 12 TO 16-9 DZU
					228.6	457.2	155.6												6.2	
1 1/8		STH-18-6	ST-18	2-12	6	16 1/8	5	3 1/2	3/4	3 3/4	2 1/2	8 1/16	7/8	1 1/4	1 3/4	3/4	6 9/16	3/8	14.1	STH 17 TO 16-6 DZU
		152.4			409.6	127.0	88.9												19.1	
		STH-18-9			9	19 1/8	6 1/2												17.4	STH 17 TO 16-9 DZU
					228.6	485.8	165.1												7.9	
	30	STH-206-6	ST-206	5206	6	16 1/8	5	3 1/2	3/4	3 3/4	2 1/2	8 1/16	7/8	1 1/4	1 3/4	3/4	6 9/16	3/8	14.1	STH 17 TO 19-6 DZU
		152.4			409.6	127.0	88.9												19.1	
		STH-206-9			9	19 1/8	6 1/2												16	STH 17 TO 19-9 DZU
					228.6	485.8	165.1												7.3	
1 3/16		STH-19-6	ST-19	2-13	6	16 1/8	5	3 1/2	3/4	3 3/4	2 1/2	8 1/16	7/8	1 1/4	1 3/4	3/4	6 9/16	3/8	14.1	STH 17 TO 19-6 DZU
		152.4			409.6	127.0	88.9												19.1	
		STH-19-9			9	19 1/8	6 1/2												16	STH 17 TO 19-9 DZU
					228.6	485.8	165.1												7.3	
1 1/4		STH-20-9	ST-20	2-14	9	19 11/16	6 13/16	3 7/8	3/4	4	2 1/2	8 1/16	1	1 1/4	1 3/4	3/4	6 9/16	3/8	16	STH 20 TO 23-9 DZU
		228.6			500.1	173.0	98.4												19.1	
		STH-20-12			12	22 11/16	8 5/16												19.5	STH 20 TO 23-12 DZU
					304.8	576.3	211.1												8.8	
1 3/8		STH-22-9	ST-22	2-16	9	19 11/16	6 13/16	3 7/8	3/4	4	2 1/2	8 1/16	1	1 1/4	1 3/4	3/4	6 9/16	3/8	17.4	STH 20 TO 23-9 DZU
		228.6			500.1	173.0	98.4												19.1	
		STH-22-12			12	22 11/16	8 5/16												19.5	STH 20 TO 23-12 DZU
					304.8	576.3	211.1												8.8	
	35	STH-207-9	ST-207	5207	9	19 11/16	6 13/16	3 7/8	3/4	4	2 1/2	8 1/16	1	1 1/4	1 3/4	3/4	6 9/16	3/8	17.4	STH 20 TO 23-9 DZU
		228.6			500.1	173.0	98.4												19.1	
		STH-207-12			12	22 11/16	8 5/16												19.5	STH 20 TO 23-12 DZU
					304.8	576.3	211.1												8.8	
1 7/16		STH-23-9	ST-23	2-17	9	19 11/16	6 13/16	3 7/8	3/4	4	2 1/2	8 1/16	1	1 1/4	1 3/4	3/4	6 9/16	3/8	17.4	STH 20 TO 23-9 DZU
		228.6			500.1	173.0	98.4												19.1	
		STH-23-12			12	22 11/16	8 5/16												19.5	STH 20 TO 23-12 DZU
					304.8	576.3	211.1												8.8	
1 1/2		STH-24-12	ST-24	2-18	12	23 9/16	8 9/16	4 1/4	7/8	4 1/4	2 1/2	9 5/16	1 3/16	1 3/8	2	7/8	7 9/16	3/8	27.2	STH 24 TO 28-12 DZU
		304.8			598.5	217.5	108.0												22.2	
		STH-24-18			18	29 9/16	11 9/16												32	STH 24 TO 28-18 DZU
					457.2	750.9	293.7												14.5	

See notes on page G-78.

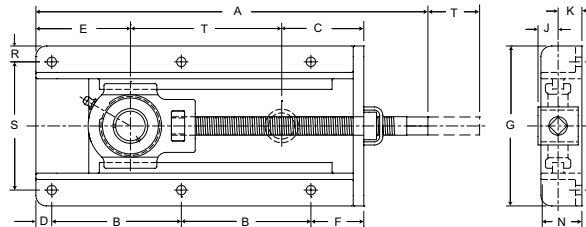
**Duty:** Standard**Rolling Elements:** Ball**Housing:** Cast Iron Center Pull Take Up Frame & Take Up Housing**Self Alignment:** +/- 2 Degrees**Lock:** Setscrew**Optional Lock:** SKWEZLOC Locking Collar**Seal:** Felt**Optional Seal:** Contact**Temperature:** -20° to 220°F

STH Center Pull Take Up Frames

Bore Diameter		Part No.	Housing Assembly Included	Bearing Insert No.	Dimensions inch / mm															Bolt Size	Unit Wt. lb/kg	Frame Only Part No.
inch	mm				T Travel	A	B	C	D	E	F	G	J	K	N	R	S					
1 9/16	40	STH-25-12	ST-25	2-19	12	23 9/16	8 9/16	4 1/4	7/8	4 1/4	2 1/2	9 5/16	1 3/16	1 3/8	2	7/8	7 9/16	3/8	27.2	STH 24 TO 28-12 DZU		
		304.8			598.5	217.5	12.3															
		STH-25-18			18	29 9/16	11 9/16	108.0	22.2	108.0	63.5	236.5	30.2	34.9	50.8	22.2	192.1		32.0	STH 24 TO 28-18 DZU		
					457.2	750.9	293.7												14.5			
1 5/8	40	STH-208-12	ST-208	5208	12	23 9/16	8 9/16	4 1/4	7/8	4 1/4	2 1/2	9 5/16	1 3/16	1 3/8	2	7/8	7 9/16	3/8	27.2	STH 24 TO 28-12 DZU		
		304.8			598.5	217.5	12.3															
		STH-208-18			18	29 9/16	11 9/16	108.0	22.2	108.0	63.5	236.5	30.2	34.9	50.8	22.2	192.1		32.0	STH 24 TO 28-18 DZU		
					457.2	750.9	293.7												14.5			
1 5/8	40	STH-26-12	ST-26	2-110	12	23 9/16	8 9/16	4 1/4	7/8	4 1/4	2 1/2	9 5/16	1 3/16	1 3/8	2	7/8	7 9/16	3/8	27.2	STH 24 TO 28-12 DZU		
		304.8			598.5	217.5	12.3															
		STH-26-18			18	29 9/16	11 9/16	108.0	22.2	108.0	63.5	236.5	30.2	34.9	50.8	22.2	192.1		32.0	STH 24 TO 28-18 DZU		
					457.2	750.9	293.7												14.5			
1 11/16	40	STH-27-12	ST-27	2-111	12	23 9/16	8 9/16	4 1/4	7/8	4 1/4	2 1/2	9 5/16	1 3/16	1 3/8	2	7/8	7 9/16	3/8	27.2	STH 24 TO 28-12 DZU		
		304.8			598.5	217.5	12.3															
		STH-27-18			18	29 9/16	11 9/16	108.0	22.2	108.0	63.5	236.5	30.2	34.9	50.8	22.2	192.1		32.0	STH 24 TO 28-18 DZU		
					457.2	750.9	293.7												14.5			
1 3/4	45	STH-28-12	ST-28	2-112	12	23 9/16	8 9/16	4 1/4	7/8	4 1/4	2 1/2	9 5/16	1 3/16	1 3/8	2	7/8	7 9/16	3/8	27.2	STH 24 TO 28-12 DZU		
		304.8			598.5	217.5	12.3															
		STH-28-18			18	29 9/16	11 9/16	108.0	22.2	108.0	63.5	236.5	30.2	34.9	50.8	22.2	192.1		32.0	STH 24 TO 28-18 DZU		
					457.2	750.9	293.7												14.5			
1 7/8	45	STH-209-12	ST-209	5209	12	23 9/16	8 9/16	4 1/4	7/8	4 1/4	2 1/2	9 5/16	1 3/16	1 3/8	2	7/8	7 9/16	3/8	27.2	STH 24 TO 28-12 DZU		
		304.8			598.5	217.5	12.3															
		STH-209-18			18	29 9/16	11 9/16	108.0	22.2	108.0	63.5	236.5	30.2	34.9	50.8	22.2	192.1		32.0	STH 24 TO 28-18 DZU		
					457.2	750.9	293.7												14.5			
1 7/8	45	STH-30-12	ST-30	2-114	12	23 11/16	8 5/8	4 3/8	7/8	4 1/4	2 1/2	9 5/16	1 9/32	1 3/8	2	7/8	7 9/16	1/2	27.2	STH 30 TO 31-12 DZU		
		304.8			601.7	219.1	12.3															
		STH-30-18			18	29 11/16	11 5/8	111.1	22.2	108.0	63.5	236.5	32.5	34.9	50.8	22.2	192.1		33.0	STH 30 TO 31-18 DZU		
					457.2	754.1	295.3												15.0			
1 15/16	45	STH-31-12	ST-31	2-115	12	23 11/16	8 5/8	4 3/8	7/8	4 1/4	2 1/2	9 5/16	1 9/32	1 3/8	2	7/8	7 9/16	1/2	27.2	STH 30 TO 31-12 DZU		
		304.8			601.7	219.1	12.3															
		STH-31-18			18	29 11/16	11 5/8	111.1	22.2	108.0	63.5	236.5	32.5	34.9	50.8	22.2	192.1		33.0	STH 30 TO 31-18 DZU		
					457.2	754.1	295.3												15.0			
2	50	STH-210-12	ST-210	5210	12	23 11/16	8 5/8	4 3/8	7/8	4 1/4	2 1/2	9 5/16	1 9/32	1 3/8	2	7/8	7 9/16	1/2	27.2	STH 30 TO 31-12 DZU		
		304.8			601.7	219.1	12.3															
		STH-210-18			18	29 11/16	11 5/8	111.1	22.2	108.0	63.5	236.5	32.5	34.9	50.8	22.2	192.1		33.0	STH 30 TO 31-18 DZU		
					457.2	754.1	295.3												15.0			
2	50	STH-32-12	ST-32	2-2	12	24 13/16	9 1/16	4 7/8	7/8	4 1/2	2 3/8	11 3/16	1 5/16	1 1/2	2 1/2	7/8	9 7/16	1/2	41.6	STH 32 TO 35-12 DZU		
		304.8			630.2	230.2	18.9															
		STH-32-18			18	30 13/16	12 1/16	123.8	22.2	114.3	60.3	284.2	33.3	38.1	63.5	22.2	239.7		50.6	STH 32 TO 35-18 DZU		
					457.2	782.6	306.4												23.0			
2 1/8	55	STH-34-12	ST-34	2-22	12	24 13/16	9 1/16	4 7/8	7/8	4 1/2	2 3/8	11 3/16	1 5/16	1 1/2	2 1/2	7/8	9 7/16	1/2	41.6	STH 32 TO 35-12 DZU		
		304.8			630.2	230.2	18.9															
		STH-34-18			18	30 13/16	12 1/16	123.8	22.2	114.3	60.3	284.2	33.3	38.1	63.5	22.2	239.7		50.6	STH 32 TO 35-18 DZU		
					457.2	782.6	306.4												23.0			
2 1/8	55	STH-211-12	ST-211	5211	12	24 13/16	9 1/16	4 7/8	7/8	4 1/2	2 3/8	11 3/16	1 5/16	1 1/2	2 1/2	7/8	9 7/16	1/2	41.6	STH 32 TO 35-12 DZU		
		304.8			630.2	230.2	18.9															
		STH-211-18			18	30 13/16	12 1/16	123.8	22.2	114.3	60.3	284.2	33.3	38.1	63.5	22.2	239.7		50.6	STH 32 TO 35-18 DZU		
					457.2	782.6	306.4												23.0			

See notes on page G-78.

Metric dimensions for reference only.

Not all parts are available from stock. Please contact customer service for availability (800) 626-2120.

For more information on bearing capabilities outside of our standard offering, please contact Application Engineering (800) 626-2093.

Performance Mounted Ball Bearings **SEALMASTER®**



- Duty:** Standard
- Rolling Elements:** Ball
- Housing:** Cast Iron Center Pull Take Up Frame & Take Up Housing
- Self Alignment:** +/- 2 Degrees
- Lock:** Setscrew
- Optional Lock:** SKWEZLOC Locking Collar
- Seal:** Felt
- Optional Seal:** Contact
- Temperature:** -20° to 220°F

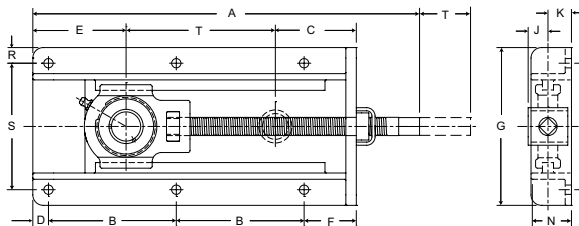

STH Center Pull Take Up Frames

Bore Diameter		Part No.	Housing Assembly Included	Bearing Insert No.	Dimensions inch / mm														Bolt Size	Unit Wt. lb/kg	Frame Only Part No.		
inch	mm				T Travel	A	B	C	D	E	F	G	J	K	N	R	S						
2 3/16		STH-35-12	ST-35	2-23	12	24 13/16	9 1/16	4 7/8	7/8	4 1/2	2 3/8	11 3/16	1 5/16	1 1/2	2 1/2	7/8	9 7/16	1/2	41.6	STH 32 TO 35-12 DZU			
		304.8			630.2	230.2	18.9																
		STH-35-18			18	30 13/16	12 1/16	123.8	22.2	114.3	60.3	284.2	33.3	38.1	63.5	22.2	239.7	1/2	50.6	STH 32 TO 35-18 DZU			
					457.2	782.6	306.4															23.0	
2 1/4		STH-36-12	ST-36	2-24	12	25 9/16	9 9/16	5 3/8	7/8	5	2 3/8	11 3/16	1 9/16	1 1/2	2 1/2	7/8	9 7/16	1/2	45.0	STH 36 TO 39-12 DZU			
		304.8			649.3	242.9	20.4																
		STH-36-18			18	31 9/16	12 9/16	136.5	22.2	127.0	60.3	284.2	39.7	38.1	63.5	22.2	239.7	1/2	53.0	STH 36 TO 39-18 DZU			
					457.2	801.7	319.1															24.0	
60		STH-212-12	ST-212	5212	12	25 9/16	9 9/16	5 3/8	7/8	5	2 3/8	11 3/16	1 9/16	1 1/2	2 1/2	7/8	9 7/16	1/2	45.0	STH 36 TO 39-12 DZU			
		304.8			649.3	242.9	20.4																
		STH-212-18			18	31 9/16	12 9/16	136.5	22.2	127.0	60.3	284.2	39.7	38.1	63.5	22.2	239.7	1/2	53.0	STH 36 TO 39-18 DZU			
					457.2	801.7	319.1															24.0	
2 3/8		STH-38-12	ST-38	2-26	12	25 9/16	9 9/16	5 3/8	7/8	5	2 3/8	11 3/16	1 9/16	1 1/2	2 1/2	7/8	9 7/16	1/2	45.0	STH 36 TO 39-12 DZU			
		304.8			649.3	242.9	20.4																
		STH-38-18			18	31 9/16	12 9/16	136.5	22.2	127.0	60.3	284.2	39.7	38.1	63.5	22.2	239.7	1/2	53.0	STH 36 TO 39-18 DZU			
					457.2	801.7	319.1															24.0	
2 7/16		STH-39-12	ST-39	2-27	12	25 9/16	9 9/16	5 3/8	7/8	5	2 3/8	11 3/16	1 9/16	1 1/2	2 1/2	7/8	9 7/16	1/2	45.0	STH 36 TO 39-12 DZU			
		304.8			649.3	242.9	20.4																
		STH-39-18			18	31 9/16	12 9/16	136.5	22.2	127.0	60.3	284.2	39.7	38.1	63.5	22.2	239.7	1/2	53.0	STH 36 TO 39-18 DZU			
					457.2	801.7	319.1															24.0	
2 1/2		STH-40-12	ST-40	3-28	12	27 1/2	10 1/4	6 3/16	7/8	5 11/16	2 1/2	12	1 11/16	2	3	7/8	10 1/4	5/8	62.5	STH 40 TO 47-12 DZU			
		304.8			698.5	260.4	28.3																
		STH-40-18			18	33 1/2	13 1/4	157.2	22.2	144.5	63.5	304.8	42.9	50.8	76.2	22.2	260.4	5/8	73.7	STH 40 TO 47-18 DZU			
					457.2	850.9	336.6															33.4	
2 11/16		STH-43-12	ST-43	2-211	12	27 1/2	10 1/4	6 3/16	7/8	5 11/16	2 1/2	12	1 11/16	2	3	7/8	10 1/4	5/8	62.5	STH 40 TO 47-12 DZU			
		304.8			698.5	260.4	28.3																
		STH-43-18			18	33 1/2	13 1/4	157.2	22.2	144.5	63.5	304.8	42.9	50.8	76.2	22.2	260.4	5/8	73.7	STH 40 TO 47-18 DZU			
					457.2	850.9	336.6															33.4	
70		STH-214-12	ST-214	5214	12	27 1/2	10 1/4	6 3/16	7/8	5 11/16	2 1/2	12	1 11/16	2	3	7/8	10 1/4	5/8	62.5	STH 40 TO 47-12 DZU			
		304.8			698.5	260.4	28.3																
		STH-214-18			18	33 1/2	13 1/4	157.2	22.2	144.5	63.5	304.8	42.9	50.8	76.2	22.2	260.4	5/8	73.7	STH 40 TO 47-18 DZU			
					457.2	850.9	336.6															33.4	
2 7/8		STH-46-12	ST-46	2-214	12	27 1/2	10 1/4	6 3/16	7/8	5 11/16	2 1/2	12	1 3/4	2	3	7/8	10 1/4	5/8	62.5	STH 40 TO 47-12 DZU			
		304.8			698.5	260.4	28.3																
		STH-46-18			18	33 1/2	13 1/4	157.2	22.2	144.5	63.5	304.8	44.5	50.8	76.2	22.2	260.4	5/8	73.7	STH 40 TO 47-18 DZU			
					457.2	850.9	336.6															33.4	
2 15/16		STH-47-12	ST-47	2-215	12	27 1/2	10 1/4	6 3/16	7/8	5 11/16	2 1/2	12	1 3/4	2	3	7/8	10 1/4	5/8	62.5	STH 40 TO 47-12 DZU			
		304.8			698.5	260.4	28.3																
		STH-47-18			18	33 1/2	13 1/4	157.2	22.2	144.5	63.5	304.8	44.5	50.8	76.2	22.2	260.4	5/8	73.7	STH 40 TO 47-18 DZU			
					457.2	850.9	336.6															33.4	
75		STH-215-12	ST-215	5215	12	27 1/2	10 1/4	6 3/16	7/8	5 11/16	2 1/2	12	1 3/4	2	3	7/8	10 1/4	5/8	62.5	STH 40 TO 47-12 DZU			
		304.8			698.5	260.4	28.3																
		STH-215-18			18	33 1/2	13 1/4	157.2	22.2	144.5	63.5	304.8	44.5	50.8	76.2	22.2	260.4	5/8	73.7	STH 40 TO 47-18 DZU			
					457.2	850.9	336.6															33.4	

The STH series style H, are side mounting frame take-up units designed to incorporate the ST series take-up units (see pages G-72 to G-74), as indicated in the accompanying charts. They are used where shaft adjustment and/or belt tightening is required in conveyor applications. They are manufactured from heavy gauge structural steel members and equipped with heavy duty Acme (square) threads for positive action. Adjustment is made by turning the square head with an open end wrench. For SKWEZLOC Locking Collar add T suffix example STH-23T-12 For Contact Seal add C suffix example STH-23C-12



Duty:	Medium
Rolling Elements:	Ball
Housing:	Cast Iron Center Pull Take Up Frame & Take Up Housing
Self Alignment:	+/- 2 Degrees
Lock:	Setscrew
Seal:	Felt
Optional Seal:	Contact
Temperature:	-20° to 220°F

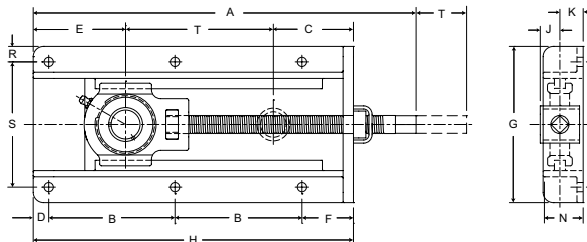

MSTH Center Pull Take Up Frames

Bore Diameter inch	Part No.	Housing Assembly Included	Bearing Insert No.	Dimensions inch / mm														Bolt Size	Unit Wt. lb/kg	Frame Only Part No.
				T Travel	A	B	C	D	E	F	G	H	J	K	N	R	S			
1 11/16	MSTH-31-12	MST-31	3-115	12	23 11/16	8 5/8	4 3/8	7/8	4 1/4	2 1/2	9 5/16	20 5/8	1 9/32	1 1/2	2 1/2	7/8	9 7/16	1/2	41.6 18.9	STH 32 TO 35-12
2	MSTH-32-12	MST-32	2-2	304.8	630.2	230.2	123.8	22.2	114.3	60.3	284.2	542.9	33.3	38.1	63.5	22.2	239.7			
2 7/16	MSTH-39-12	MST-39	3-27	12	25 9/16	9 9/16	5 3/8	7/8	5	2 3/8	11 3/16	22 3/8	1 9/16	1 1/2	2 1/2	7/8	9 7/16	5/8	62.5 28.3	STH 40 TO 47-12
2 1/2	MSTH-40-12	MST-40	3-28	304.8	698.5	260.4	157.2	22.2	144.5	63.5	304.8	606.4	44.5	50.8	76.2	22.2	260.4			

The MSTH series style H, are side mounting take-up units designed to incorporate MST series take-up units (see page G-80) as indicated in the table above. They are used where shaft adjustment and/or belt tightening is required in conveyor applications. They are manufactured from heavy gauge structural steel members and equipped with heavy duty Acme (square) threads for positive action. Adjustment is made by turning the square head with an open wrench.

Metric dimensions for reference only.

Not all parts are available from stock. Please contact customer service for availability (800) 626-2120.

For more information on bearing capabilities outside of our standard offering, please contact Application Engineering (800) 626-2093.



Duty: Standard
Rolling Elements: Ball
Housing: Cast Iron Top Mount Take Up Frame & Pillow Block Housing
Self Alignment: +/- 2 Degrees
Lock: Setscrew
Optional Lock: SKWEZLOC Locking Collar
Seal: Felt
Optional Seal: Contact
Temperature: -20° to 220°F

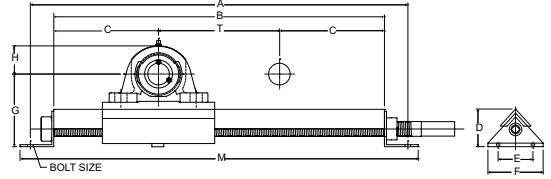
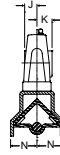

NPG and SPG Series Style “G” Protected Screw Take Ups – Setscrew Locking

Bore Diameter		Part No.	Housing Assembly Included	Bearing Insert No.	Dimensions inch / mm															Bolt Size	Unit Wt. lb/kg	Frame Only Part No.			
inch	mm				T Travel	A	B	M	C	D	E	F	G	H	J	K	N	O							
7/8		NPG-14-6	NP-14	2-014	6	18	15 1/4	19 1/2	4 5/8	2 5/16	2 1/2	3 3/4	4 1/8	1 3/8	9/16	13/16	1 9/16	1/4	3/8	12.4	NPG 14 TO 16-6 DZW				
		152.4			457.2	387.4	495.3	117.5												58.7		63.5	95.3	104.8	34.9
		NPG-14-9			9	21	18 1/4	22 1/2																13.5	NPG 14 TO 16-9 DZW
					228.6	533.4	463.6	571.5																6.12	
15/16		NPG-15-6	NP-15	2-015	6	18	15 1/4	19 1/2	4 5/8	2 5/16	2 1/2	3 3/4	4 1/8	1 3/8	9/16	13/16	1 9/16	1/4	3/8	12.4	NPG 14 TO 16-6 DZW				
		152.4			457.2	387.4	495.3	117.5												58.7		63.5	95.3	104.8	34.9
		NPG-15-9			9	21	18 1/4	22 1/2																13.5	NPG 14 TO 16-9 DZW
					228.6	533.4	463.6	571.5																6.12	
1		NPG-16-6	NP-16	2-1	6	18	15 1/4	19 1/2	4 5/8	2 5/16	2 1/2	3 3/4	4 1/8	1 3/8	9/16	13/16	1 9/16	1/4	3/8	12.4	NPG 14 TO 16-6 DZW				
		152.4			457.2	387.4	495.3	117.5												58.7		63.5	95.3	104.8	34.9
		NPG-16-9			9	21	18 1/4	22 1/2																13.5	NPG 14 TO 16-9 DZW
					228.6	533.4	463.6	571.5																6.12	
	25	NPG-205-6	NP-205	5205	6	18	15 1/4	19 1/2	4 5/8	2 5/16	2 1/2	3 3/4	4 1/8	1 3/8	9/16	13/16	1 9/16	1/4	3/8	12.4	NPG 14 TO 16-6 DZW				
		152.4			457.2	387.4	495.3	117.5												58.7		63.5	95.3	104.8	34.9
		NPG-205-9			9	21	18 1/4	22 1/2																13.5	NPG 14 TO 16-9 DZW
					228.6	533.4	463.6	571.5																6.12	
1 1/8		NPG-18-6	NP-18	2-12	6	19	16 1/4	20 1/2	5 1/8	2 5/16	2 1/2	3 3/4	4 3/8	1 11/16	5/8	7/8	1 3/4	1/4	3/8	16.1	NPG 17 TO 19-6 DZW				
		152.4			482.6	412.8	520.7	130.2												58.7		63.5	95.3	111.1	42.9
		NPG-18-9			9	22	19 1/4	23 1/2																17.1	NPG 17 TO 19-9 DZW
					228.6	558.8	489.0	596.9																7.76	
1 3/16		NPG-19-6	NP-19	2-13	6	19	16 1/4	20 1/2	5 1/8	2 5/16	2 1/2	3 3/4	4 3/8	1 11/16	5/8	7/8	1 3/4	1/4	3/8	16.1	NPG 17 TO 19-6 DZW				
		152.4			482.6	412.8	520.7	130.2												58.7		63.5	95.3	111.1	42.9
		NPG-19-9			9	22	19 1/4	23 1/2																17.1	NPG 17 TO 19-9 DZW
					228.6	558.8	489.0	596.9																7.76	
	30	NPG-206-6	NP-206	5206	6	19	16 1/4	20 1/2	5 1/8	2 5/16	2 1/2	3 3/4	4 3/8	1 11/16	5/8	7/8	1 3/4	1/4	3/8	16.1	NPG 17 TO 19-6 DZW				
		152.4			482.6	412.8	520.7	130.2												58.7		63.5	95.3	111.1	42.9
		NPG-206-9			9	22	19 1/4	23 1/2																17.1	NPG 17 TO 19-9 DZW
					228.6	558.8	489.0	596.9																7.76	
1 1/4		NPG-20-9	NP-20	2-14	9	22 1/4	19 1/2	23 3/4	5 1/4	2 5/16	2 1/2	3 3/4	4 9/16	1 7/8	11/16	1	1 3/4	1/4	3/8	17.7	NPG 20 TO 23-9 DZW				
		228.6			565.2	495.3	603.3	133.4												58.7		63.5	95.3	115.9	47.6
		NPG-20-12			12	25 1/4	22 1/2	26 3/4																19.1	NPG 20 TO 23-12 DZW
					304.8	641.4	571.5	679.5																8.66	
1 3/8		NPG-22-9	NP-22	2-16	9	22 1/4	19 1/2	23 3/4	5 1/4	2 5/16	2 1/2	3 3/4	4 9/16	1 7/8	11/16	1	1 3/4	1/4	3/8	17.7	NPG 20 TO 23-9 DZW				
		228.6			565.2	495.3	603.3	133.4												58.7		63.5	95.3	115.9	47.6
		NPG-22-12			12	25 1/4	22 1/2	26 3/4																19.1	NPG 20 TO 23-12 DZW
					304.8	641.4	571.5	679.5																8.66	
1 7/16		NPG-23-9	NP-23	2-17	9	22 1/4	19 1/2	23 3/4	5 1/4	2 5/16	2 1/2	3 3/4	4 9/16	1 7/8	11/16	1	1 3/4	1/4	3/8	17.7	NPG 20 TO 23-9 DZW				
		228.6			565.2	495.3	603.3	133.4												58.7		63.5	95.3	115.9	47.6
		NPG-23-12			12	25 1/4	22 1/2	26 3/4																19.1	NPG 20 TO 23-12 DZW
					304.8	641.4	571.5	679.5																8.66	
	35	NPG-207-9	NP-207	5207	9	22 1/4	19 1/2	23 3/4	5 1/4	2 5/16	2 1/2	3 3/4	4 9/16	1 7/8	11/16	1	1 3/4	1/4	3/8	17.7	NPG 20 TO 23-9 DZW				
		228.6			565.2	495.3	603.3	133.4												58.7		63.5	95.3	115.9	47.6
		NPG-207-12			12	25 1/4	22 1/2	26 3/4																19.1	NPG 20 TO 23-12 DZW
					304.8	641.4	571.5	679.5																8.66	
1 1/2		NPG-24-12	NP-24	2-18	12	26	23 1/4	27 1/2	5 5/8	2 5/16	2 1/2	3 3/4	4 5/8	2	3/4	1 3/16	2 1/16	1/4	3/8	25.6	NPG 24 TO 28-12 DZW				
		304.8			660.4	590.6	698.5	142.9												58.7		63.5	95.3	117.5	50.8
		NPG-24-18			18	32	29 1/4	33 1/2																27.6	NPG 24 TO 28-18 DZW
					457.2	812.8	743.0	850.9																12.52	

See notes on page G-82.

SEALMASTER® Performance Mounted Ball Bearings



- Duty:** Standard
- Rolling Elements:** Ball
- Housing:** Cast Iron Top Mount Take Up Frame & Pillow Block Housing
- Self Alignment:** +/- 2 Degrees
- Lock:** Setscrew
- Optional Lock:** SKWEZLOC Locking Collar
- Seal:** Felt
- Optional Seal:** Contact
- Temperature:** -20° to 220°F

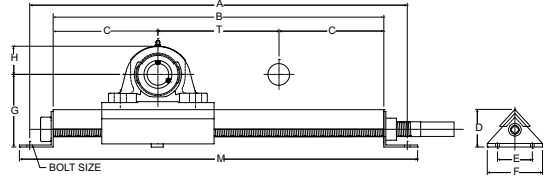
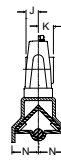

NPG and SPG Series Style “G” Protected Screw Take Ups – Setscrew Locking

Bore Diameter		Part No.	Housing Assembly Included	Bearing Insert No.	Dimensions inch / mm															Bolt Size	Unit Wt. lb/kg	Frame Only Part No.
inch	mm				T Travel	A	B	M	C	D	E	F	G	H	J	K	N	O				

See notes on page G-82.
 Metric dimensions for reference only.
 Not all parts are available from stock. Please contact customer service for availability (800) 626-2120.
 For more information on bearing capabilities outside of our standard offering, please contact Application Engineering (800) 626-2093.

Performance Mounted Ball Bearings

SEALMASTER®

Mtd. Ball Bearings



- Duty:** Standard
- Rolling Elements:** Ball
- Housing:** Cast Iron Top Mount Take Up Frame & Pillow Block Housing
- Self Alignment:** +/- 2 Degrees
- Lock:** Setscrew
- Optional Lock:** SKWEZLOC Locking Collar
- Seal:** Felt
- Optional Seal:** Contact
- Temperature:** -20° to 220°F

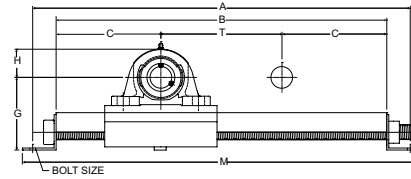
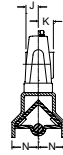

NPG and SPG Series Style “G” Protected Screw Take Ups – Setscrew Locking

Bore Diameter		Part No.	Housing Assembly Included	Bearing Insert No.	Dimensions inch / mm															Bolt Size	Unit Wt. lb/kg	Frame Only Part No.			
inch	mm				T Travel	A	B	M	C	D	E	F	G	H	J	K	N	O							
2 3/16		NPG-35-12	NP-35	2-23	12	27 1/4	24 1/2	29															1/2	36.6 16.60	NPG 32 TO 35-12 DZW
					304.8	692.2	622.3	736.6	6 1/4	211/16	3	4 3/4	59/16	2 1/2	7/8	1 5/16	2 7/16	5/16	7.9	40.1 18.19	NPG 32 TO 35-18 DZW				
		NPG-35-18	18	33 1/4	30 1/2	35	158.8	68.3	76.2	120.7	141.3	63.5	22.2	33.3	61.9	7.9									
2 1/4		SPG-36-12	SP-36	2-24	12	30	27 1/4	31 1/4															5/8	48.9 22.18	SPG 36 TO 39-12 DZW
					304.8	762.0	692.2	793.8	7 5/8	211/16	3	4 3/4	63/16	215/16	1	19/16	2 7/16	5/16	7.9	52.1 23.63	SPG 36 TO 39-18 DZW				
		SPG-36-18	18	36	33 1/4	37 3/4	193.7	68.3	76.2	120.7	157.2	74.6	25.4	39.7	61.9	7.9									
2 3/8		SPG-38-12	SP-38	2-26	12	30	27 1/4	31 1/4															5/8	48.9 22.18	SPG 36 TO 39-12 DZW
					304.8	762.0	692.2	793.8	7 5/8	211/16	3	4 3/4	63/16	215/16	1	19/16	2 7/16	5/16	7.9	52.1 23.63	SPG 36 TO 39-18 DZW				
		SPG-38-18	18	36	33 1/4	37 3/4	193.7	68.3	76.2	120.7	157.2	74.6	25.4	39.7	61.9	7.9									
2 7/16	60	SPG-39-12	SP-39	2-27	12	30	27 1/4	31 1/4															5/8	48.9 22.18	SPG 36 TO 39-12 DZW
					304.8	762.0	692.2	793.8	7 5/8	211/16	3	4 3/4	63/16	215/16	1	19/16	2 7/16	5/16	7.9	52.1 23.63	SPG 36 TO 39-18 DZW				
		SPG-39-18	18	36	33 1/4	37 3/4	193.7	68.3	76.2	120.7	157.2	74.6	25.4	39.7	61.9	7.9									
2 1/2	70	SPG-40-12	SP-40	3-28	12	31 1/2	28 3/4	33 1/2															5/8	67.2 30.48	SPG 40 TO 47-12 DZW
					304.8	800.1	730.3	850.9	8 3/8	3 1/4	3	5	7 1/2	3 3/8	1 1/16	111/16	213/16	3/8	9.5	69.2 31.39	SPG 40 TO 47-18 DZW				
		SPG-40-18	18	37 1/2	34 3/4	39 1/2	212.7	82.6	76.2	127.0	190.5	85.7	27.0	42.9	71.4	9.5									
2 11/16	70	SPG-43-12	SP-43	2-211	12	31 1/2	28 3/4	33 1/2															5/8	67.2 30.48	SPG 40 TO 47-12 DZW
					304.8	800.1	730.3	850.9	8 3/8	3 1/4	3	5	7 1/2	3 3/8	1 1/16	111/16	213/16	3/8	9.5	69.2 31.39	SPG 40 TO 47-18 DZW				
		SPG-43-18	18	37 1/2	34 3/4	39 1/2	212.7	82.6	76.2	127.0	190.5	85.7	27.0	42.9	71.4	9.5									
2 7/8	70	SPG-46-12	SP-46	2-214	12	31 1/2	28 3/4	33 1/2															5/8	67.6 30.66	SPG 40 TO 47-12 DZW
					304.8	800.1	730.3	850.9	8 3/8	3 1/4	3	5	7 1/2	3 7/16	1 5/16	1 3/4	213/16	3/8	9.5	69.8 31.66	SPG 40 TO 47-18 DZW				
		SPG-46-18	18	37 1/2	34 3/4	39 1/2	212.7	82.6	76.2	127.0	190.5	87.3	33.3	44.5	71.4	9.5									
2 15/16	75	SPG-47-12	SP-47	2-215	12	31 1/2	28 3/4	33 1/2															5/8	67.6 30.66	SPG 40 TO 47-12 DZW
					304.8	800.1	730.3	850.9	8 3/8	3 1/4	3	5	7 1/2	3 7/16	1 5/16	1 3/4	213/16	3/8	9.5	69.8 31.66	SPG 40 TO 47-18 DZW				
		SPG-47-18	18	37 1/2	34 3/4	39 1/2	212.7	82.6	76.2	127.0	190.5	87.3	33.3	44.5	71.4	9.5									
2 7/8	75	SPG-215-12	SP-215	5215	12	31 1/2	28 3/4	33 1/2															5/8	67.6 30.66	SPG 40 TO 47-12 DZW
					304.8	800.1	730.3	850.9	8 3/8	3 1/4	3	5	7 1/2	3 7/16	1 5/16	1 3/4	213/16	3/8	9.5	69.8 31.66	SPG 40 TO 47-18 DZW				
		SPG-215-18	18	37 1/2	34 3/4	39 1/2	212.7	82.6	76.2	127.0	190.5	87.3	33.3	44.5	71.4	9.5									

Series NPG and SPG are top mounted protected screw take-up units incorporating standard duty pillow blocks, as indicated in the accompanying charts. They are used where shaft adjustment and/or belt tightening is required in conveyor applications. They are manufactured from heavy gauge structural steel and equipped with heavy duty Acme (square) threads for positive action. Adjustment is made by turning the square head screw with an open end wrench.

Part numbers shown include standard duty setscrew locking pillow block NP (see pages G-31 to G-32) or SP (see pages G-36 to G-37) as indicated.
 For SKWEZLOC Locking Collar add T suffix example NPG-32T-18
 For Contact Seal add C suffix example NPG-32C-18

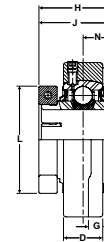
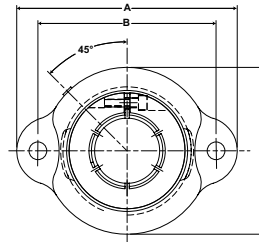

Duty: Standard
Rolling Elements: Ball
Housing: Ductile Iron Two Bolt Flange
Self Alignment: +/- 2 Degrees
Lock: Concentric
Lock: SKWEZLOC Locking Collar
Seal: Felt
Optional Seal: Contact
Temperature: -20° to 220°F

Options

- 1 Grease Fitting



- 2 Adapter Fitting

TFT-T Series Standard Duty Two-Bolt Flange Units - SKWEZLOC Locking Collar

Bore Diameter inch	Part No.			Part No.	Basic Dynamic Rating lb/N	Dimensions inch / mm								Bolt Size	Unit Wt. lb/kg
	Standard With Plug	With Grease Fitting	With Adapter Fitting			A	B	C	D	H	K	L	N		
15/16	TFT-15TC	TFT-15TC-1	TFT-15TC-2	2-015TC	2801	3 3/4	3	2 3/4	11/16	1 1/2	1 7/16	1 15/16	9/16	3/8	1.6
1	TFT-16TC	TFT-16TC-1	TFT-16TC-2	2-1TC	12459	95.3	76.2	69.9	17.5	38.1	36.5	49.2	14.3		0.73
1 1/8	TFT-18TC	TFT-18TC-1	TFT-18TC-2	2-12TC	4381 19487	4 7/16 112.7	3 9/16 90.5	3 1/4 82.6	13/16 20.6	1 5/8 41.3	1 9/16 39.7	2 3/16 55.6	5/8 15.9	3/8	2.3 1.04
1 3/16	TFT-19TC	TFT-19TC-1	TFT-19TC-2	2-13TC											
1 1/4	TFT-20RT*	TFT-20RT*	TFT-20RT*	1-14T	5782 25718	4 7/8 123.8	3 15/16 100.0	3 11/16 93.7	7/8 22.2	1 13/16 46.0	1 3/4 44.5	2 7/16 61.9	11/16 17.5	3/8	3 1.36
1 1/4	TFT-20TC	TFT-20TC-1	TFT-20TC-2	2-14TC											
1 3/8	TFT-22TC	TFT-22TC-1	TFT-22TC-2	2-16TC	5782 25718	4 7/8 123.8	3 15/16 100.0	3 11/16 93.7	7/8 22.2	1 13/16 46.0	1 3/4 44.5	2 9/16 65.1	11/16 17.5	3/8	3 1.36
1 7/16	TFT-23TC	TFT-23TC-1	TFT-23TC-2	2-17TC											

For standard duty SKWEZLOC Locking Collar Bearing inserts, see page G-93.

*1 1/4 Reduced not available with contact seal, felt only.

Metric dimensions for reference only.

Not all parts are available from stock. Please contact customer service for availability (800) 626-2120.

For more information on bearing capabilities outside of our standard offering, please contact Application Engineering (800) 626-2093.



- Duty:** Light
- Rolling Elements:** Ball
- Housing:** Stamped Steel Rubber Mounted Flange
- Lock:** Setscrew
- Seal:** Felt
- Optional Seal:** Contact
- Temperature:** -20° to 220°F
- Relube:** No

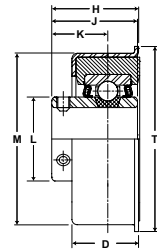
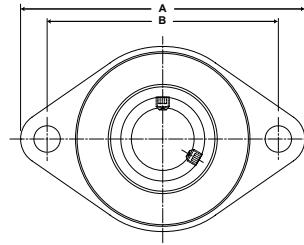

SRF Series Light Duty Rubber Mounted Flange Blocks - Setscrew Locking

Bore Diameter inch	Part No.	Bearing Insert No.	Max. Steady Radial Loads lb/N	Dimensions inch / mm									Bolt Size	Unit Wt. lb/kg
				A	B	D	H	J	K	M	T	Hole Size		
1/2	SRF-8	SRC-8	400	4 1/2	3 5/8	1 3/32	1 3/8	1 9/32	7/8	2 41/64	2 45/64	7/16	3/8	.75
5/8	SRF-10	SRC-10	1779	114.3	92.1	27.8	34.9	32.5	22.2	67.1	68.7	11.1		.34
3/4	SRF-12	SRC-12												
7/8	SRF-14	SRC-14	400	4 1/2	3 5/8	1 3/32	1 3/8	1 3/8	7/8	2 41/64	2 45/64	7/16	3/8	.85
15/16	SRF-15	SRC-15	1779	114.3	92.1	27.8	34.9	34.9	22.2	67.1	68.7	11.1		.39
1	SRF-16	SRC-16												
1 1/8	SRF-18	SRC-18	600	5 3/8	4 3/8	1 1/4	1 21/32	1 5/8	1 1/16	3 1/4	3 1/2	1/2	7/16	1.50
1 3/16	SRF-19	SRC-19	2669	136.5	111.1	31.8	42.1	41.3	27.0	82.6	88.9	12.7		.68
1 1/4	SRF-20R	SRC-20R												

Maximum steady radial load is based upon the housing strength and materials composition. Thrust load ratings 40% of radial loads..



Duty: Light
Rolling Elements: Ball
Housing: Stamped Steel Rubber Mounted Pillow Block
Lock: Setscrew
Seal: Felt
Optional Seal: Contact
Temperature: -20° to 220°F
Relube: No

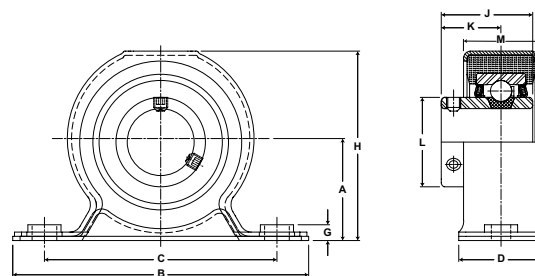

SRP Series Light Duty Rubber Mounted Pillow Blocks - Setscrew Locking

Bore Diameter inch	Part No.	Bearing Insert No.	Max. Steady Radial Loads lb/N	Dimensions inch / mm									Hole Size	Bolt Size	Unit Wt. lb/kg
				A	B	C	D	G	H	J	K	M			
1/2	SRP-8	SRC-8	200 890	1 1/2 38.1	4 3/4 120.7	3 5/8 92.1	1 5/16 33.3	11/64 4.4	2 13/16 71.4	1 9/32 32.5	7/8 22.2	1 1/8 28.6	7/16 11.1	3/8	.85 .39
5/8	SRP-10	SRC-10													
3/4	SRP-12	SRC-12													
7/8	SRP-14	SRC-14	200 890	1 1/2 38.1	4 3/4 120.7	3 5/8 92.1	1 5/16 33.3	11/64 4.4	2 13/16 71.4	1 3/8 34.9	7/8 22.2	1 1/8 28.6	7/16 11.1	3/8	1 .45
15/16	SRP-15	SRC-15													
1	SRP-16	SRC-16													
1 1/8	SRP-18	SRC-18	300 1334	1 3/4 44.5	5 1/4 133.4	4 1/8 104.8	1 1/2 38.1	7/32 5.6	3 3/8 85.7	1 5/8 41.3	1 1/16 27.0	1 11/32 34.1	7/16 11.1	3/8	1.6 .73
1 3/16	SRP-19	SRC-19													
1 1/4	SRP-20R	SRC-20R													

Maximum steady radial load is based upon the housing strength and materials composition. Thrust load rating 40% of radial loads.

Metric dimensions for reference only.

Not all parts are available from stock. Please contact customer service for availability (800) 626-2120.

For more information on bearing capabilities outside of our standard offering, please contact Application Engineering (800) 626-2093.



- Duty:** Light
- Rolling Elements:** Ball
- Housing:** Rubber Mounted Insert
- Lock:** Setscrew
- Seal:** Felt
- Optional Seal:** Contact
- Temperature:** -20° to 220°F
- Relube:** No

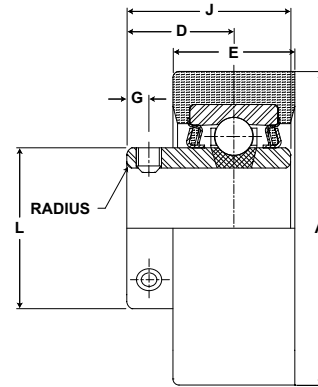

SRC Series Light Duty Rubber Mounted Cartridge Units - Setscrew Locking

Bore Diameter inch	Part No.	Bearing Insert No.	Max. Steady Radial Loads lb/N	Dimensions inch / mm						Unit Wt. lb/kg
				A	D	E	G	L	J	
1/2	SRC-8	RB-8								
5/8	SRC-10	RB-10	200 890	2 17/32 64.3	7/8 22.2	1 25.4	3/16 4.8	1 3/16 30.2	1 9/32 32.5	.60 .27
3/4	SRC-12	RB-12								
7/8	SRC-14	RB-14								
15/16	SRC-15	RB-15	200 890	2 17/32 64.3	7/8 22.2	1 25.4	3/16 4.8	1 3/8 34.9	1 3/8 34.9	.65 .29
1	SRC-16	RB-16								
1 1/8	SRC-18	RB-18								
1 3/16	SRC-19	RB-19	300 1334	3 3/32 78.6	1 1/16 27.0	1 13/64 30.6	7/32 5.6	1 19/32 40.5	1 5/8 41.3	1.00 .45
1 1/4	SRC-20R	RB-20R								

Maximum steady radial load is based upon the housing strength and materials composition. Thrust load ratings 40% of radial loads.



Duty: Light
Rolling Elements: Ball
Lock: Setscrew
Seal: Felt
Optional Seal: Contact
Temperature: -20° to 220°F
Relube: No

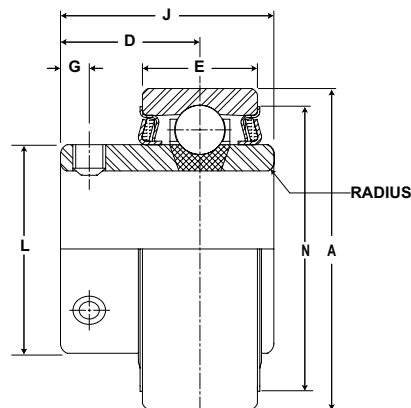

RB Series Bearing Assemblies

Bore Diameter inch	Part No.	Basic Dynamic Rating lb/N	Dimensions inch / mm							Max. Rad. to Clear	Setscrew Thread	Unit Wt. lb/kg
			A	D	E	G	J	L	N			
1/2	RB-8											
5/8	RB-10	2611 11614	1.850 47.00	7/8 22.2	5/8 15.9	3/16 4.8	1 9/32 32.5	1 3/16 30.2	1 5/8 41.3	.040 1.02	1/4-28	.50 .23
3/4	RB-12											
7/8	RB-14											
15/16	RB-15	2801 12459	2.047 52.00	7/8 22.2	3/4 19.1	3/16 4.8	1 3/8 34.9	1 3/8 34.9	1 55/64 47.2	.040 1.02	1/4-28	.60 .27
1	RB-16											
1 1/8	RB-18											
1 3/16	RB-19	4381 19487	2.441 62.00	1 1/16 27.0	7/8 22.2	7/32 5.6	1 5/8 41.3	1 9/32 32.5	1 19/32 40.5	.040 1.02	1/4-28	.90 .41
1 1/4	RB-20R											

Outside diameter may be oversized due to seal press fit.

Metric dimensions for reference only.

Not all parts are available from stock. Please contact customer service for availability (800) 626-2120.

For more information on bearing capabilities outside of our standard offering, please contact Application Engineering (800) 626-2093.



- Duty:** Standard
- Rolling Elements:** Ball
- Self Alignment:** +/- 2 Degrees
- Lock:** Setscrew
- Seal:** Felt
- Optional Seal:** Contact
- Temperature:** -20° to 220°F

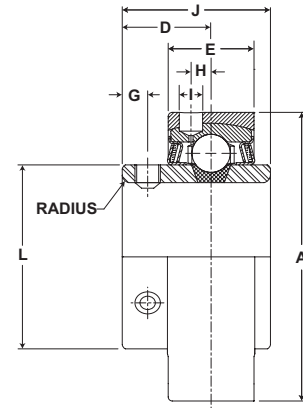

AR Series Standard Duty Expansion Insert - Setscrew Locking

Bore Diameter		Part No.	Bearing Insert No.	Basic Dynamic Rating lb/N	Dimensions inch / mm								Max Rad. To Clear	Setscrew Thread	Unit Wt. lb/kg
inch	mm				A +0.000" -0.005"	D	E	G	H	I	J	L			
1/2	20	AR-2-08	2-08	2611	2.062	23/32	49/64	3/16	1/8	1/4	1 7/32	1 3/16	.040	1/4-28	.8
9/16		AR-2-09	2-09												
5/8		AR-2-010	2-010												
11/16		AR-2-011	2-011												
3/4	AR-2-012	2-012	11614	52.375	18.3	19.4	4.8	3.2	6.4	31.0	30.2	1.02		.36	
AR-204	5204														
13/16	25	AR-2-013	2-013	2801	2.272	13/16	49/64	7/32	11/64	1/4	1 3/8	1 3/8	.040	1/4-28	1.0
7/8		AR-2-014	2-014												
15/16		AR-2-015	2-015												
1		AR-2-1	2-1												
AR-205	5205														.45
1 1/16	30	AR-2-11	2-11	4381	2.687	7/8	61/64	7/32	7/32	1/4	1 1/2	1 19/32	.040	1/4-28	1.5
1 1/8		AR-2-12	2-12												
1 3/16		AR-2-13	2-13												
1 1/4		AR-1-14	1-14												
AR-206	5206														.68
1 1/4	35	AR-2-14	2-14	5782	3.140	1	1 1/64	1/4	1/4	1/4	1 11/16	1 55/64	.040	5/16-24	2.1
1 5/16		AR-2-15	2-15												
1 3/8		AR-2-16	2-16												
1 7/16		AR-2-17	2-17												
AR-207	5207														.95
1 1/2	40	AR-2-18	2-18	7340	3.375	1 3/16	1 11/64	5/16	19/64	1/4	1 15/16	2 1/16	.062	5/16-24	2.8
1 9/16		AR-2-19	2-19												
		AR-208	5208												
															1.27
1 5/8	45	AR-2-110	2-110	7901	3.562	1 3/16	1 11/64	5/16	19/64	1/4	1 15/16	2 19/64	.062	5/16-24	3
1 11/16		AR-2-111	2-111												
1 3/4		AR-2-112	2-112												
		AR-209	5209												
															1.36
1 13/16	50	AR-2-113	2-113	7889	3.875	1 9/32	1 13/64	3/8	17/64	11/32	2 1/32	2 15/32	.062	3/8-24	3.5
1 7/8		AR-2-114	2-114												
1 15/16		AR-2-115	2-115												
2		AR-1-2	1-2												
AR-210	5210														1.59
2	55	AR-2-2	2-2	9752	4.250	1 5/16	1 17/64	3/8	19/64	11/32	2 3/16	2 23/32	.080	3/8-24	4.4
2 1/8		AR-2-22	2-22												
2 3/16		AR-2-23	2-23												
		AR-211	5211												
															2.00
2 1/4	60	AR-2-24	2-24	11789	4.718	1 9/16	1 21/64	7/16	21/64	11/32	2 9/16	2 63/64	.080	3/8-24	5.8
2 3/8		AR-2-26	2-26												
2 7/16		AR-2-27	2-27												
		AR-212	5212												
															2.63
2 11/16	70	AR-2-211	2-211	13971	5.170	1 11/16	1 29/64	7/16	3/8	11/32	2 3/4	3 7/16	.080	7/16-20	9.3
		AR-214	5214												
															4.22
2 7/8	75	AR-2-214	2-214	14839	5.375	1 3/4	1 37/64	7/16	3/8	11/32	3 1/16	3 41/64	.080	7/16-20	9.6
2 15/16		AR-2-215	2-215												
		AR-215	5215												
															4.35
3 3/16	80	AR-2-233	2-233	17412	5.875	1 15/16	1 53/64	17/32	13/32	15/32	3 1/4	3 59/64	.120	7/16-20	12.2
3.150		AR-216	5216												
															5.53
3 1/4	90	AR-2-34	2-34	18681	6.280	2 1/32	2 5/64	15/32	17/32	15/32	3 3/8	4 5/32	.120	7/16-20	15.2
3 3/8		AR-2-36	2-36												
3 7/16		AR-2-37	2-37												
															6.89
3 1/2	AR-2-38	2-38	21566	6.750	2 7/32	2 9/64	5/8	15/32	15/32	3 25/32	4 25/64	.120	1/2-20	18.5	
	AR-218	5218	95926	171.450	56.4	54.4	15.9	11.9	11.9	96.0	111.5	3.05		8.39	

For Standard Duty Bearing Inserts - Single Lock see page G-92.

SEALMASTER® Performance Mounted Ball Bearings



Duty: Standard
Rolling Elements: Ball
Self Alignment: +/- 2 Degrees
Lock: SKWEZLOC Locking Collar
Seal: Felt
Optional Seal: Contact
Temperature: -20° to 220°F

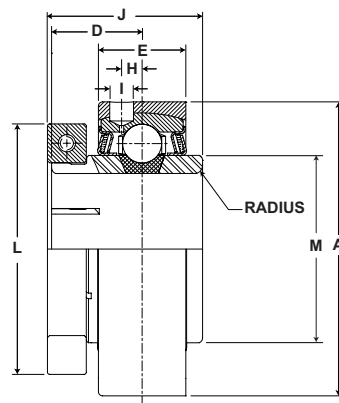

AR-T Standard Duty Expansion Insert - SKWEZLOC Locking Collar - Inch

Bore Diameter inch	Part No.	Bearing Insert No.	Basic Dynamic Rating lb/N	Dimensions inch / mm									Max Rad. To Clear	Torx Cap Screw	Unit Wt. lb/kg
				A +.000" -.005"	D	E	H	I	J	L	M				
3/4	AR-2-012T	2-012T	2611 11614	2.0620 52.375	25/32 22.8	49/64 19.4	9/64 3.6	1/4 6.4	1 9/32 35.5	1 3/4 44.5	1 3/16 30.2	.040 1.02	T-25	.9 .41	
15/16 1	AR-2-015T AR-2-1T	2-015T 2-1T	2801 12459	2.2720 57.709	7/8 22.2	49/64 19.4	11/64 4.4	1/4 6.4	1 7/16 36.5	1 15/16 49.2	1 3/8 34.9	.040 1.02	T-25	1.2 .54	
1 1/8	AR-2-12T	2-12T	4381 19487	2.6870 68.250	15/16 22.8	61/64 24.2	7/32 5.6	1/4 6.4	1 9/16 35.5	2 3/16 55.6	1 19/32 40.5	.040 1.02	T-25	1.7 .77	
1 1/4	AR-2-14T	2-14T	5782 25718	3.1400 79.756	1 1/16 27.0	1 1/64 25.8	1/4 6.4	1/4 6.4	1 3/4 44.5	2 7/16 61.9	1 55/64 47.2	.040 1.02	T-27	2.4 1.09	
1 3/8 1 7/16	AR-2-16T AR-2-17T	2-16T 2-17T	5782 25718	3.1400 79.756	1 1/16 27.0	1 1/64 25.8	1/4 6.4	1/4 6.4	1 3/4 44.5	2 9/16 65.1	1 55/64 47.2	.040 1.02	T-27	2.4 1.09	
1 1/2	AR-2-18T	2-18T	7340 32648	3.3750 85.725	1 1/4 31.8	1 11/64 29.8	19/64 7.5	1/4 6.4	2 50.8	2 11/16 68.3	2 1/16 52.4	.062 1.57	T-27	3.1 1.41	
1 5/8	AR-2-110T	2-110T	7901 35144	3.5620 90.475	1 1/4 31.8	1 11/64 29.8	19/64 7.5	1/4 6.4	2 50.8	2 13/16 71.4	2 19/64 58.3	.062 1.57	T-27	3.3 1.50	
1 11/16 1 3/4	AR-2-111T AR-2-112T	2-111T 2-112T	7901 35144	3.5620 90.475	1 1/4 31.8	1 11/64 29.8	19/64 7.5	1/4 6.4	2 50.8	2 15/16 74.6	2 19/64 58.3	.062 1.57	T-27	3.3 1.50	
1 15/16	AR-2-115T	2-115T	7889 35090	3.8750 98.425	1 11/32 34.1	1 13/64 30.6	17/64 6.7	11/32 8.7	2 3/32 53.2	3 3/8 85.7	2 15/32 62.7	.062 1.57	T-30	4.1 1.86	
2	AR-2-2T	2-2T	9752 43377	4.2500 107.950	1 3/8 34.9	1 17/64 32.1	19/64 7.5	11/32 8.7	2 1/4 57.2	3 1/2 88.9	2 23/32 69.1	.080 2.03	T-30	5.0 2.27	
2 3/16	AR-2-23T AR-211TMC	2-23T 5211TMC	9752 43377	4.2500 107.950	1 3/8 34.9	1 17/64 32.1	19/64 7.5	11/32 8.7	2 1/4 57.2	3 5/8 92.1	2 23/32 69.1	.080 2.03	T-30	5.0 2.27	
2 1/4	AR-2-24T	2-24T	11789 52437	4.7190 119.863	1 5/8 41.3	1 21/64 33.7	21/64 8.3	11/32 8.7	2 5/8 66.7	4 1/16 103.2	2 63/64 75.8	.080 2.03	T-45	7.0 3.18	
2 3/8 2 7/16	AR-2-26T AR-2-27T	2-26T 2-27T	11789 52437	4.7190 119.863	1 5/8 41.3	1 21/64 33.7	21/64 8.3	11/32 8.7	2 5/8 66.7	4 1/8 104.8	2 63/64 75.8	.080 2.03	T-45	7.0 3.18	

AR-T Standard Duty Expansion Insert - Metric - SKWEZ™

Bore Diameter mm	Part No.	Bearing Insert No.	Basic Dynamic Rating lb/N	Dimensions mm / inch									Max Rad. To Clear	Torx Cap Screw	Unit Wt. kg/lb
				A +.000mm -.125mm	D	E	H	I	J	L	M				
20	AR-204TMC	5204TMC	11614 2611	52.375 2.0620	22.8 25/32	19.4 49/64	3.6 9/64	6.4 1/4	35.5 1 9/32	44.5 1 3/4	30.2 1 3/16	.040 1.02	T-25	.41 .9	
25	AR-205TMC	5205TMC	12459 2801	57.709 2.2720	22.2 7/8	19.4 49/64	4.4 11/64	6.4 1/4	36.5 1 7/16	49.2 1 15/16	34.9 1 3/8	.040 1.02	T-25	.54 1.2	
30	AR-206TMC	5206TMC	19487 4381	68.250 2.6870	22.8 15/16	24.2 61/64	5.6 7/32	6.4 1/4	35.5 1 9/16	55.6 2 3/16	40.5 1 19/32	.040 1.02	T-25	.77 1.7	
35	AR-207TMC	5207TMC	25718 5782	79.756 3.1400	27.0 1 1/16	25.8 1 1/64	6.4 1/4	6.4 1/4	44.5 1 3/4	65.1 2 9/16	47.2 1 55/64	.040 1.02	T-27	1.09 2.4	
40	AR-208TMC	5208TMC	32648 7340	85.725 3.3750	31.8 1 1/4	29.8 1 11/64	7.5 19/64	6.4 1/4	50.8 2	68.3 2 11/16	52.4 2 1/16	.062 1.57	T-27	1.41 3.1	
45	AR-209TMC	5209TMC	35144 7901	90.475 3.5620	31.8 1 1/4	29.8 1 11/64	7.5 19/64	6.4 1/4	50.8 2	74.6 2 15/16	58.3 2 19/64	.062 1.57	T-27	1.50 3.3	
50	AR-210TMC	5210TMC	35090 7889	98.425 3.8750	34.1 1 11/32	30.6 1 13/64	6.7 17/64	8.7 11/32	53.2 2 3/32	85.7 3 3/8	62.7 2 15/32	.062 1.57	T-30	1.86 4.1	
55	AR-211TMC	5211TMC	43377 9752	107.950 4.2500	34.9 1 3/8	32.1 1 17/64	7.5 19/64	8.7 11/32	57.2 2 1/4	92.1 3 5/8	69.1 2 23/32	.080 2.03	T-30	2.27 5.0	
60	AR-212TMC	5212TMC	52437 11789	119.863 4.7190	41.3 1 5/8	33.7 1 21/64	8.3 21/64	8.7 11/32	66.7 2 5/8	104.8 4 1/8	75.8 2 63/64	.080 2.03	T-45	3.18 7.0	

For Standard Duty Bearing Inserts - SKWEZLOC Locking collar see page G-93.



- Duty:** Medium
- Rolling Elements:** Ball
- Self Alignment:** +/- 2 Degrees
- Lock:** Setscrew
- Seal:** Felt
- Optional Seal:** Contact
- Temperature:** -20° to 220°F

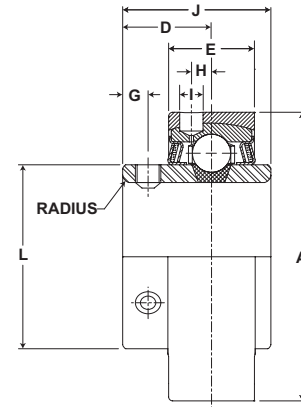

AR Series Medium Duty Expansion Insert - Setscrew Locking

Bore Diameter		Part No.	Bearing Insert No.	Basic Dynamic Rating lb/N	Dimensions Inch / mm								Max Rad. To Clear	Setscrew Thread	Unit Wt. lb/kg
					A	D	E	G	H	I	J	L			
inch	mm				+0.000" -0.005"										
15/16 1	25	AR-3-015	3-015	4381	2.687	7/8	61/64	7/32	7/32	1/4	1 1/2	1 19/32	.040	1/4-28	1.5
		AR-3-1	3-1	19487	68.250	22.2	24.2	5.6	5.6	6.4	38.1	40.5	1.02		.68
		AR-305	5305												
1 3/16	30	AR-3-13	3-13	5782	3.14	1	1 1/64	1/4	1/4	1/4	1 11/16	1 55/64	.040	5/16-24	2.1
		AR-306	5306	25718	79.756	25.4	25.8	6.4	6.4	6.4	42.9	47.2	1.02		.95
1 7/16	35	AR-3-17	3-17	7340	3.375	1 3/16	1 11/64	5/16	19/64	1/4	1 15/16	2 1/16	.062	5/16-24	2.8
		AR-307	5307	32648	85.725	30.2	29.8	7.9	7.5	6.4	49.2	52.4	1.57		1.27
1 1/2	40	AR-3-18	3-18	7901	3.562	1 3/16	1 11/64	5/16	19/64	1/4	1 15/16	2 19/64	.062	5/16-24	3
		AR-308	5308	35144	90.475	30.2	29.8	7.9	7.5	6.4	49.2	58.3	1.57		1.36
1 11/16 1 3/4	45	AR-3-111	3-111	7889	3.875	1 9/32	1 13/64	3/8	17/64	11/32	2 1/32	2 15/32	.062	3/8-24	3.5
		AR-3-112	3-112	35090	98.425	32.5	30.6	9.5	6.7	8.7	51.6	62.7	1.57		1.59
		AR-309	5309												
1 15/16	50	AR-3-115	3-115	9752	4.25	1 5/16	1 17/64	3/8	19/64	11/32	2 3/16	2 23/32	.080	3/8-24	4.4
		AR-310	5310	43377	107.950	33.3	32.1	9.5	7.5	8.7	55.6	69.1	2.03		2.00
2 3/16	55	AR-3-23	3-23	11789	4.718	1 9/16	1 21/64	7/16	21/64	11/32	2 9/16	2 63/64	.080	3/8-24	5.8
		AR-311	5311	52437	119.837	39.7	33.7	11.1	8.3	8.7	65.1	75.8	2.03		2.63
2 7/16 2 1/2	65	AR-3-27	3-27	13971	5.17	1 11/16	1 29/64	7/16	3/8	11/32	2 3/4	3 7/16	.080	7/16-20	9.3
		AR-3-28	3-28	62143	131.318	42.9	36.9	11.1	9.5	8.7	69.9	87.3	2.03		4.22
		AR-313	5313												
2 11/16	70	AR-3-211	3-211	14839	5.375	1 3/4	1 37/64	7/16	3/8	11/32	3 1/16	3 41/64	.080	7/16-20	9.6
		AR-314	5314	66004	136.525	44.5	40.1	11.1	9.5	8.7	77.8	92.5	2.03		4.35
2 15/16 3	75	AR-3-215	3-215	17412	5.875	1 15/16	1 53/64	17/32	13/32	15/32	3 1/4	3 59/64	.120	7/16-20	12.2
		AR-3-3	3-3	77449	149.225	49.2	46.4	13.5	10.3	11.9	82.6	99.6	3.05		5.53
		AR-315	5315												
3 3/16	80	AR-3-33	3-33	18681	6.28	2 1/32	2 5/64	15/32	17/32	15/32	3 3/8	4 5/32	.120	7/16-20	15.2
		AR-316	5316	83093	159.512	51.6	52.8	11.9	13.5	11.9	85.7	105.6	3.05		6.89
3 7/16		AR-3-37	3-37	21566	6.75	2 7/32	2 9/64	5/8	15/32	15/32	3 25/32	4 25/64	.120	1/2-20	18.5
				95926	171.450	56.4	54.4	15.9	11.9	11.9	96.0	111.5	3.05		8.39
3 15/16 4	100	AR-3-315	3-5315	29905	8.063	2 11/16	2 33/64	3/4	19/32	15/32	4 5/8	5 11/64	.120	5/8-18	32.9
		AR-3-4	3-4	133017	204.800	68.3	63.9	19.1	15.1	11.9	117.5	131.4	3.05		14.92
		AR-320	320												

For Medium Duty Bearing Inserts - Single Lock see page G-95.

SEALMASTER® Performance Mounted Ball Bearings



Duty: Medium
Rolling Elements: Ball
Housing: Brass Expansion Insert
Self Alignment: +/- 2 Degrees
Lock: SKWEZLOC Locking Collar
Seal: Felt
Optional Seal: Contact
Temperature: -20° to 220°F

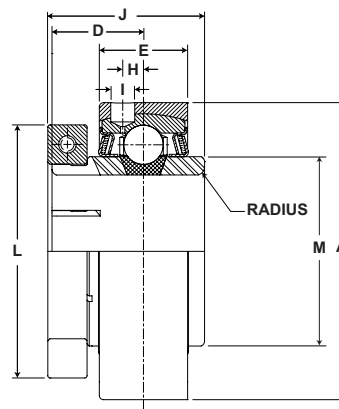

AR-T Medium Duty Expansion Insert - SKWEZLOC Locking Collar

Bore Diameter inch	Part No.	Bearing Insert No.	Basic Dynamic Rating lb/N	Dimensions inch / mm								Max Rad. To Clear	Torx Cap Screw	Unit Wt. lb/kg
				A +.000" -.005"	D	E	H	I	J	L	M			
1	AR-3-1T	3-1T	4381 19487	2.687 68.250	15/16 23.8	61/64 24.2	7/32 5.6	1/4 6.4	1 9/16 39.7	2 1/16 52.4	1 19/32 40.5	.040 1.02	T-25	1.7 .77
1 1/4	AR-2-14T	2-14T	5782 25718	3.14 79.756	1 1/16 27.0	1 25.4	1/4 6.4	1/4 6.4	1 3/4 44.5	2 7/16 61.9	1 27/32 46.8	.040 1.02	T-27	2.4 1.09
1 7/16	AR-3-17T	3-17T	7340 32648	3.375 85.725	1 1/4 31.8	1 11/64 29.8	19/64 7.5	1/4 6.4	2 50.8	2 11/16 68.3	2 1/16 52.4	.062 1.57	T-27	3.1 1.41
1 1/2	AR-3-18T	3-18T	7901 35144	3.562 90.475	1 1/4 31.8	1 11/64 29.8	19/64 7.5	1/4 6.4	2 50.8	2 13/16 71.4	2 5/16 58.7	.062 1.57	T-27	3.3 1.50
1 11/16	AR-3-111T	3-111T	7889	3.875	1 11/32	1 13/64	17/64	11/32	2 3/32	3 1/4	2 15/32	.062	T-30	4.1
1 3/4	AR-3-112T	3-112T	35090	98.425	34.1	30.6	6.7	8.7	53.2	82.6	62.7	1.57		1.86
1 15/16	AR-3-115T	2-115T	7889 35090	4.25 107.950	1 3/8 34.9	1 17/64 32.1	19/64 7.5	11/32 8.7	2 1/4 57.2	3 1/2 88.9	2 23/32 69.1	.080 2.03	T-30	5.0 2.27
2 3/16	AR-3-23T	3-23T	11789 52437	4.719 119.863	1 5/8 41.3	1 21/64 33.7	21/64 8.3	11/32 8.7	2 5/8 66.7	4 1/16 103.2	2 63/64 75.8	.080 2.03	T-45	7.0 3.18

For Medium Duty SKWEZLOC Locking Collar Bearing inserts see page G-96.

Metric dimensions for reference only.

Not all parts are available from stock. Please contact customer service for availability (800) 626-2120.

For more information on bearing capabilities outside of our standard offering, please contact Application Engineering (800) 626-2093.



Duty: Standard
Rolling Elements: Ball
Lock: Setscrew
Seal: Felt
Optional Seal: Contact
Temperature: -20° to 220°F

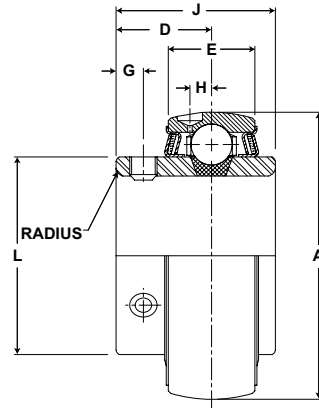

Standard Duty Bearing Insert – Setscrew

Bore Diameter		Part No.	Basic Dynamic Rating lb/N	Dimensions Inch / mm							Max Rad. To Clear	Setscrew Thread	Unit Wt. lb/kg
inch	mm			A	D	E	G	H	J	L			
1/2	20	2-08	2611 11614	1.8504 47	23/32 18.3	5/8 15.9	3/16 4.8	1/8 3.2	1 7/32 31.0	1 3/16 30.2	.040 1.02	1/4-28	.5 .23
9/16		2-09											
5/8		2-010											
11/16		2-011											
3/4		2-012 5204											
13/16	25	2-013	2801 12459	2.0472 52	13/16 20.6	11/16 17.5	7/32 5.6	11/64 4.4	1 3/8 34.9	1 3/8 34.9	.040 1.02	1/4-28	.6 .27
7/8		2-014											
15/16		2-015											
1		2-1 5205											
1 1/16	30	2-11	4381 19487	2.4409 62	7/8 22.2	7/8 22.2	7/32 5.6	7/32 5.6	1 1/2 38.1	1 19/32 40.5	.040 1.02	1/4-28	1.0 .45
1 1/8		2-12											
1 3/16		2-13											
1 1/4		1-14 5206											
1 1/4	35	2-14	5782 25718	2.8316 72	1 25.4	15/16 23.8	1/4 6.4	1/4 6.4	1 11/16 42.9	1 55/64 47.2	.040 1.02	5/16-24	1.5 .68
1 5/16		2-15											
1 3/8		2-16											
1 7/16		2-17 5207											
1 1/2	40	2-18	7340 32648	3.1490 80	1 3/16 30.2	1 3/32 27.8	5/16 7.9	19/64 7.5	1 15/16 49.2	2 1/16 52.4	.062 1.57	5/16-24	1.9 .86
1 9/16		2-19 5208											
1 5/8		2-110											
1 11/16		2-111											
1 3/4	45	2-112	7901 35144	3.3465 85	1 3/16 30.2	1 3/32 27.8	5/16 7.9	19/64 7.5	1 15/16 49.2	2 19/64 58.3	.062 1.57	5/16-24	2.2 1.00
1 13/16		2-113											
1 7/8		2-114											
1 15/16		2-115											
2	50	1-2 5210	7889 35090	3.5433 90	1 9/32 32.5	1 1/8 28.6	3/8 9.5	17/64 6.7	2 1/32 51.6	2 15/32 62.7	.062 1.57	3/8-24	2.4 1.09
2		2-2											
2 1/8		2-22											
2 3/16		2-23 5211											
2 1/4	60	2-24	11789 52437	4.3307 110	1 9/16 39.7	1 1/4 31.8	7/16 11.1	21/64 8.3	2 9/16 65.1	2 63/64 75.8	.080 2.03	3/8-24	3.7 1.68
2 3/8		2-26											
2 7/16		2-27 5212											
2 11/16		2-211											
2 7/8	70	2-214	13971 62143	4.9213 125	1 11/16 42.9	1 3/8 34.9	7/16 11.1	3/8 9.5	2 3/4 69.9	3 7/16 87.3	.080 2.03	7/16-20	5.45 2.47
2 15/16		2-215											
3 3/16		2-233											
3 1/4		2-236											
3 3/8	80	2-237	14839 66004	5.1181 130	1 3/4 44.5	1 1/2 38.1	7/16 11.1	3/8 9.5	3 1/16 77.8	3 41/64 92.5	.080 2.03	7/16-20	6.8 3.08
3 7/16		2-216											
3 1/2		2-238											
3 3/4		2-239											
3 1/2	90	2-240	17412 77449	5.5118 140	1 15/16 49.2	1 11/16 42.9	17/32 13.5	13/32 10.3	3 1/4 82.6	3 59/64 99.6	.120 3.05	7/16-20	7.2 3.27
3 3/8		2-241											
3 7/8		2-242											
4		2-243											
3 1/4	90	2-34	18681 83093	5.9055 150	2 1/32 51.6	1 15/16 49.2	15/32 11.9	17/32 13.5	3 3/8 85.7	4 5/32 105.6	.120 3.05	7/16-20	9.3 4.22
3 3/8		2-36											
3 7/16		2-37											
3 1/2		2-38											
3 1/2	90	5218	21566 95926	6.2992 160	2 7/32 56.4	2 50.8	5/8 15.9	15/32 11.9	3 25/32 96.0	4 25/64 111.5	.120 3.05	1/2-20	11.7 5.31

SEALMASTER® Performance Mounted Ball Bearings



Duty: Standard
Rolling Elements: Ball
Lock: SKWEZLOC Locking Collar
Seal: Felt
Optional Seal: Contact
Temperature: -20° to 220°F

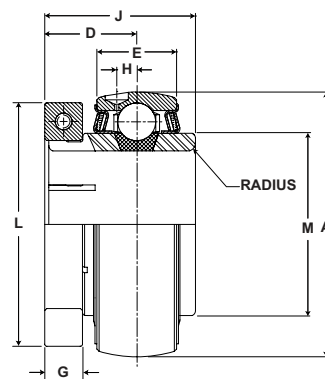

Standard Duty Bearing Insert – SKWEZLOC Locking Collar

Bore Diameter		Part No.	Basic Dynamic Rating lb/N	Dimensions inch / mm								Max Rad. To Clear	Torx Cap Screw	Unit Wt. lb/kg
inch	mm			A	D	E	G	H	J	L	M			
3/4	20	2-012T	2611	1.8504	23/32	5/8	3/8	9/64	1 9/32	1 3/4	1 3/16	.040	T-25	.60
		5204TMC	11614	47	18.3	15.9	9.5	3.6	32.5	44.5	30.2	1.02		.27
15/16	25	2-015T	2801	2.0472	13/16	11/16	3/8	11/64	1 7/16	1 15/16	1 3/8	.040	T-25	.80
		2-1T	12459	52	20.6	17.5	9.5	4.4	36.5	49.2	34.9	1.02		.36
		5205TMC												
1 1/8	30	2-12T	4381	2.4409	7/8	7/8	3/8	7/32	1 9/16	2 3/16	1 19/32	.040	T-25	1.2
		2-13T	19487	62	22.2	22.2	9.5	5.6	39.7	55.6	40.5	1.02		.54
		1-14T	5206TMC											
1 1/4		2-14T	5782	2.8346	1	15/16	7/16	1/4	1 3/4	2 7/16	1 55/64	.040	T-27	1.8
		25718	72	25.4	23.8	11.1	6.4	44.5	61.9	47.2	1.02	.82		
1 3/8	35	2-16T	5782	2.8346	1	15/16	7/16	1/4	1 3/4	2 9/16	1 55/64	.040	T-27	1.8
		2-17T	25718	72	25.4	23.8	11.1	6.4	44.5	65.1	47.2	1.02		.82
		5207TMC												
1 1/2	40	2-18T	7340	3.1496	1 3/16	1 3/32	7/16	19/64	2	2 11/16	2 1/16	.062	T-27	2.2
		2-19T	32648	80	30.2	27.8	11.1	7.5	50.8	68.3	52.4	1.57		1.00
		5208TMC												
1 5/8		2-110T	7901	3.3465	1 3/16	1 3/32	7/16	19/64	2	2 13/16	2 19/64	.062	T-27	2.5
		35144	85	30.2	27.8	11.1	7.5	50.8	71.4	58.3	1.57	1.13		
1 11/16	45	2-111T	7901	3.3465	1 3/16	1 3/32	7/16	19/64	2	2 15/16	2 19/64	.062	T-27	2.5
		2-112T	35144	85	30.2	27.8	11.1	7.5	50.8	74.6	58.3	1.57		1.13
		5209TMC												
1 15/16	50	2-115T	7889	3.5433	1 9/32	1 1/8	9/16	17/64	2 3/32	3 3/8	2 15/32	.062	T-30	3.0
		1-2T	35090	90	32.5	28.6	14.3	6.7	53.2	85.7	62.7	1.57		1.36
		5210TMC												
2		2-2T	9752	3.9370	1 5/16	1 3/16	9/16	19/64	2 1/4	3 1/2	2 23/32	.080	T-30	3.4
		43377	100	33.3	30.2	14.3	7.5	57.2	88.9	69.1	2.03	1.54		
2 1/8	55	2-22T	9752	3.9370	1 5/16	1 3/16	9/16	19/64	2 1/4	3 5/8	2 23/32	.080	T-30	3.4
		2-23T	43377	100	33.3	30.2	14.3	7.5	57.2	92.1	69.1	2.03		1.54
		5211TMC												
2 1/4		2-24T	11789	4.3307	1 9/16	1 1/4	11/16	21/64	2 5/8	4 1/16	2 63/64	.080	T-45	4.9
		52437	110	39.7	31.8	17.5	8.3	66.7	103.2	75.8	2.03	2.22		
2 3/8	60	2-26T	11789	4.3307	1 9/16	1 1/4	11/16	21/64	2 5/8	4 1/8	2 63/64	.080	T-45	4.9
		2-27T	52437	110	39.7	31.8	17.5	8.3	66.7	104.8	75.8	2.03		2.22
		5212TMC												

Metric dimensions for reference only.

Not all parts are available from stock. Please contact customer service for availability (800) 626-2120.

For more information on bearing capabilities outside of our standard offering, please contact Application Engineering (800) 626-2093.



Duty: Standard
Rolling Elements: Ball
Lock: Double Setscrew
Seal: Felt
Optional Seal: Contact
Temperature: -20° to 220°F

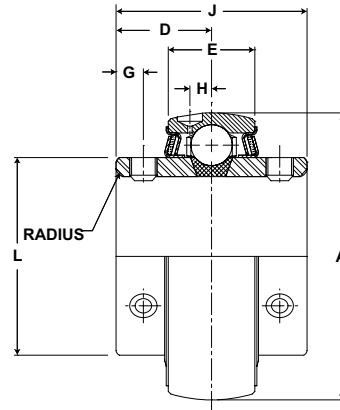

Standard Duty Bearing Insert – Double Setscrew

Bore Diameter inch	Bearing Insert No.	Basic Dynamic Rating lb/N	Dimensions inch / mm							Max Rad. To Clear	Setscrew Thread	Unit Wt. lb/kg
			A	D	E	G	H	J	L			
7/8	2-014D	2801	2.0472	3/4	11/16	7/32	11/64	1 1/2	1 3/8	.040	1/4-28	.6
15/16	2-015D	12459	52	19.1	17.5	5.6	4.4	38	34.9	1.02		.27
1	2-1D											
1 3/16	2-13D	4381 19487	2.4409 62	7/8 22.2	7/8 22.2	7/32 5.6	7/32 5.6	1 3/4 44	1 19/32 40.5	.040 1.02	1/4-28	1.0 .45
1 1/4	2-14D	5782	2.8346	1	15/16	1/4	1/4	2	1 55/64	.040	5/16-24	1.5
1 3/8	2-16D	25718	72	25.4	23.8	6.4	6.4	51	47.2	1.02		.68
1 7/16	2-17D											
1 1/2	2-18D	7340	3.1496	1 5/32	1 3/32	5/16	19/64	2 5/16	2 1/16	.062	5/16-24	1.9
1 9/16	2-19D	32648	80	29.4	27.8	7.9	7.5	59	52.4	1.57		.86
1 11/16	2-111D	7901	3.3465	1 3/16	1 3/32	11/32	19/64	2 3/8	2 19/64	.062	5/16-24	2.2
1 3/4	2-112D	35144	85	30.2	27.8	8.7	7.5	60	58.3	1.57		1.00
1 7/8	2-114D	7889	3.5433	1 1/4	1 1/8	11/32	17/64	2 1/2	2 15/32	.062	3/8-24	2.4
1 15/16	2-115D	35090	90	31.8	28.6	8.7	6.7	64	62.7	1.57		1.09
2	2-2D	9752	3.9370	1 5/16	1 3/16	5/16	19/64	2 5/8	2 23/32	.080	3/8-24	2.8
2 1/8	2-22D	43377	100	33.3	30.2	7.9	7.5	67	69.1	2.03		1.27
2 3/16	2-23D											
2 1/4	2-24D	11789	4.3307	1 9/16	1 1/4	13/32	21/64	3 1/8	2 63/64	.080	3/8-24	3.7
2 3/8	2-26D	52437	110	39.7	31.8	10.3	8.3	79	75.8	2.03		1.68
2 7/16	2-27D											
2 11/16	2-211D	13971 62143	4.9213 125	1 3/4 44.5	1 3/8 34.9	15/32 11.9	3/8 9.5	3 1/2 89	3 7/16 87.3	.080 2.03	7/16-20	5.8 2.63
2 7/8	2-214D	14839	5.1181	1 3/4	1 1/2	7/16	3/8	3 1/2	3 41/64	.080	7/16-20	6.8
2 15/16	2-215D	66004	130	44.5	38.1	11.1	9.5	89	92.5	2.03		3.08
3 3/16	2-33D	17412 77449	5.5118 140	1 15/16 49.2	1 11/16 42.9	9/16 14.3	13/32 10.3	3 7/8 98	3 59/64 99.6	.120 3.05	7/16-20	7.2 3.27
3 1/4	2-34D	18681	5.9055	2 1/32	1 15/16	1/2	17/32	4 1/16	4 5/32	.120	7/16-20	9.3
3 3/8	2-36D	83093	150	51.6	49.2	12.7	13.5	103	105.6	3.05		4.22
3 7/16	2-37D											
3 1/2	2-38D	21566 95926	6.2992 160	2 7/32 56.4	2 50.8	1/2 12.7	15/32 11.9	4 7/16 113	4 25/64 111.5	.120 3.05	1/2-20	11.7 5.31



Duty: Medium
Rolling Elements: Ball
Lock: Setscrew
Seal: Felt
Optional Seal: Contact
Temperature: -20° to 220°F

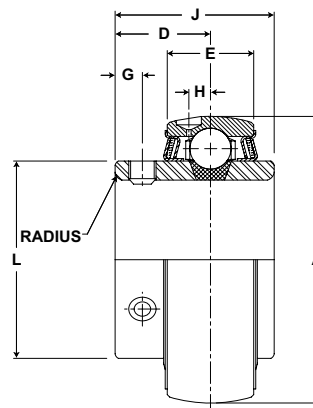

Medium Duty Bearing Insert – Setscrew

Bore Diameter		Bearing Insert No.	Basic Dynamic Rating lb/N	Dimensions inch / mm							Max Rad. To Clear	Setscrew Thread	Unit Wt. lb/kg
inch	mm			A	J	D	E	L	G	H			
15/16 1	25	3-015	4381	2.4409	1 1/2	7/8	7/8	1 19/32	7/32	7/32	.040	1/4-28	1.0
		3-1	19487	62	38.1	22.2	22.2	40.5	5.6	5.6	1.02		.45
		5305											
1 3/16 1.181	30	3-13	5782	2.8346	1 11/16	1	15/16	1 55/64	1/4	1/4	.040	5/16-24	1.5
		5306	25718	72	42.9	25.4	23.8	47.2	6.4	6.4	1.02		.68
1 7/16	35	3-17	7340	3.1496	1 15/16	1 3/16	1 3/32	2 1/16	5/16	19/64	.062	5/16-24	1.9
		5307	32648	80	49.2	30.2	27.8	52.4	7.9	7.5	1.57		.86
1 1/2	40	3-18	7901	3.3465	1 15/16	1 3/16	1 3/32	2 19/64	5/16	19/64	.062	5/16-24	2.2
		5308	35144	85	49.2	30.2	27.8	58.3	7.9	7.5	1.57		1.00
1 11/16 1 3/4	45	3-111	7889	3.5433	2 1/32	1 9/32	1 1/8	2 15/32	3/8	17/64	.062	3/8-24	2.4
		3-112	35090	90	51.6	32.5	28.6	62.7	9.5	6.7	1.57		1.09
		5309											
1 15/16	50	3-115	9752	3.9370	2 3/16	1 5/16	1 3/16	2 23/32	3/8	19/64	.080	3/8-24	3.2
		5310	43377	100	55.6	33.3	30.2	69.1	9.5	7.5	2.03		1.45
2 3/16	55	3-23	11789	4.3307	2 9/16	1 9/16	1 1/4	2 63/64	7/16	21/64	.080	3/8-24	4.2
		5311	52437	110	65.1	39.7	31.8	75.8	11.1	8.3	2.03		1.91
2 7/16 2 1/2	65	3-27	13971	4.9213	2 3/4	1 11/16	1 3/8	3 7/16	7/16	3/8	.080	7/16-20	6.5
		3-28	62143	125	69.9	42.9	34.9	87.3	11.1	9.5	2.03		2.95
		5313											
2 11/16	70	3-211	14839	5.1181	3 1/16	1 3/4	1 1/2	3 41/64	7/16	3/8	.080	7/16-20	7.1
		5314	66004	130	77.8	44.5	38.1	92.5	11.1	9.5	2.03		3.22
2 15/16 3	75	3-215	17412	5.5118	3 1/4	1 15/16	1 11/16	3 59/64	17/32	13/32	.120	7/16-20	8.2
		3-3	77449	140	82.6	49.2	42.9	99.6	13.5	10.3	3.05		3.72
		5315											
3 3/16	80	3-33	18681	5.9055	3 3/8	2 1/32	1 15/16	4 5/32	15/32	17/32	.120	7/16-20	10.0
		5316	83093	150	85.7	51.6	49.2	105.6	11.9	13.5	3.05		4.54
3 7/16	80	3-37	21566	6.2992	3 25/32	2 7/32	2	4 25/64	5/8	15/32	.120	1/2-20	11.7
		95926	160	96.0	56.4	50.8	111.5	15.9	11.9	3.05	5.31		
3 15/16 4	100	3-315	29905	7.4803	4 5/8	2 11/16	2 1/2	5 11/64	3/4	19/32	.120	5/8-18	20.4
		3-4	133017	190	117.5	68.3	63.5	131.4	19.1	15.1	3.05		9.25
	5320												

Metric dimensions for reference only.

Not all parts are available from stock. Please contact customer service for availability (800) 626-2120.

For more information on bearing capabilities outside of our standard offering, please contact Application Engineering (800) 626-2093.



Duty: Medium
Rolling Elements: Ball
Lock: SKWEZLOC Locking Collar
Seal: Felt
Optional Seal: Contact
Temperature: -20° to 220°F

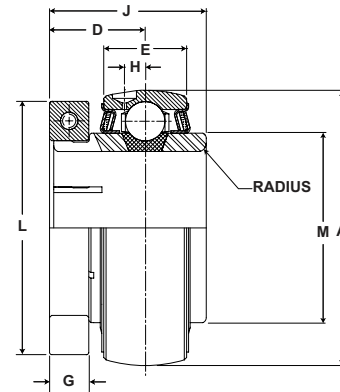

Medium Duty Bearing Insert - SKWEZLOC Locking Collar

Bore Diameter		Part No.	Basic Dynamic Rating lb/N	Dimensions inch / mm								Max Rad. To Clear	Torx Cap Screw	Unit Wt. lb/kg
inch	mm			A	J	D	E	G	H	L	M			
1	25.4	3-1T	4381	2.4409	1 9/16	7/8	7/8	3/8	7/32	2 1/16	1 19/32	.040	T-25	1.2
			19487	62	39.7	22.2	22.2	9.5	5.6	52.4	40.5	1.02		.54
1 3/16	30.2	3-13T	5782	2.8346	1 3/4	1	15/16	7/16	1/4	2 7/16	1 55/64	.040	T-27	1.8
			25718	72	44.5	25.4	23.8	11.1	6.4	61.9	47.2	1.02		.82
1 7/16	36.5	3-17T	7340	3.1496	2	1 3/16	1 3/32	7/16	19/64	2 11/16	2 1/16	.062	T-27	2.2
			32648	80	50.8	30.2	27.8	11.1	7.5	68.3	52.4	1.57		1.00
1 1/2	38.1	3-18T	7901	3.3470	2	1 3/16	1 3/32	7/16	19/64	2 13/16	2 19/64	.062	T-27	2.5
			35144	85	50.8	30.2	27.8	11.1	7.5	71.4	58.3	1.57		1.13
1 11/16	42.9	3-111T	7889	3.5433	2 3/32	1 9/32	1 1/8	9/16	17/64	3 1/4	2 15/32	0.062	T-30	3.0
1 3/4	44.5	3-112T	35090	90	53.2	32.5	28.6	14.3	6.7	82.6	62.7	1.57		1.36
1 15/16	49.2	3-115T	9752	3.9370	2 1/4	1 5/16	1 3/16	9/16	19/64	3 1/2	2 23/32	.080	T-30	3.8
			43377	100	57.2	33.3	30.2	14.3	7.5	88.9	69.1	2.03		1.72
2 3/16	55.6	3-23T	11789	4.3307	2 5/8	1 9/16	1 1/4	11/16	21/64	4 1/16	2 63/64	.080	T-45	4.9
			52437	110	66.7	39.7	31.8	17.5	8.3	103.2	75.8	2.03		2.22



Duty: Medium
Rolling Elements: Ball
Lock: Double Setscrew
Seal: Felt
Optional Seal: Contact
Temperature: -20° to 220°F

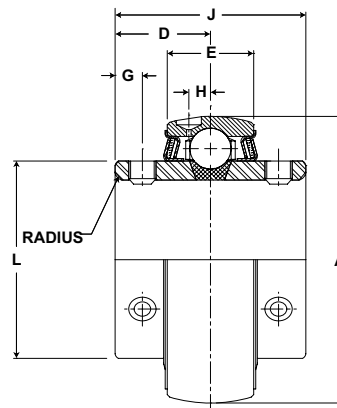

Medium Duty Bearing Insert – Double Setscrew

Bore Diameter inch	Part No.	Basic Dynamic Rating lb/N	Dimensions inch / mm							Max Rad. To Clear	Setscrew Thread	Unit Wt. lb/kg
			A	D	E	G	H	L	J			
1	3-1D	4381	2.4409	7/8	7/8	7/32	7/32	1 19/32	1 3/4	.040	1/4-28	1.0
		19487	62	22.2	22.2	5.6	5.6	40.5	44.5	1.02		.45
1 3/16	3-13D	5782	2.8346	1	15/16	1/4	1/4	1 55/64	2	.040	5/16-24	1.5
			72	25.4	23.8	6.4	6.4	47.2	50.8	1.02		.68
1 7/16	3-17D	7340	3.1496	1 5/32	1 3/32	31/99	19/64	2 1/16	2 5/16	.062	5/16-24	2.0
		32648	80	29.4	27.8	8.0	7.5	52.4	58.7	1.57		.91
1 1/2	3-18D	7901	3.3470	1 3/16	1 3/32	11/32	19/64	2 19/64	2 3/8	.062	5/16-24	2.5
			85	30.2	27.8	8.7	7.5	58.3	60.3	1.57		1.13
1 11/16	3-111D	7889	3.5433	1 1/4	1 1/8	11/32	17/64	2 15/32	2 1/2	.062	3/8-24	2.7
		35090	90	31.8	28.6	8.7	6.7	62.7	63.5	1.57		1.22
1 15/16	3-115D	9752	3.9370	1 5/16	1 3/16	31/99	19/64	2 23/32	2 5/8	.080	3/8-24	3.5
			100	33.3	30.2	8.0	7.5	69.1	66.7	2.03		1.59
2 7/16	3-27D	13971	4.9207	1 3/4	1 3/8	15/32	3/8	3 7/16	3 1/2	.080	7/16-20	7.1
		62143	125	44.5	34.9	11.9	9.5	87.3	88.9	2.03		3.22
2 11/16	3-211D	14839	5.1181	1 3/4	1 1/2	39/99	3/8	3 41/64	3 1/2	.080	1/2-20	7.3
			130	44.5	38.1	11.1	9.5	92.5	88.9	2.03		3.31
2 15/16	3-215D	17412	5.5118	1 15/16	1 11/16	49/87	13/32	3 59/64	3 7/8	.120	1/2-20	9
		77449	140	49.2	42.9	14.3	10.3	99.6	98.4	3.05		4.08
3 3/16	3-33D	18681	5.9055	2 1/32	1 15/16	1/2	17/32	4 5/32	4 1/16	.120	1/2-20	10.8
			150	51.6	49.2	12.7	13.5	105.6	103.2	3.05		4.90
3 7/16	3-37D	21566	6.2992	2 7/32	2	1/2	15/32	4 25/64	4 7/16	.120	1/2-20	12.6
		95926	160	56.4	50.8	12.7	11.9	111.5	112.7	3.05		5.72
3 15/16	3-315D	29905	7.4803	2 11/16	2 1/2	64/89	19/32	5 11/64	5 3/8	.120	5/8-18	21.6
		133017	190	68.3	63.5	18.3	15.1	131.4	136.5	3.05		9.80
4 7/16	3-47D	37482	9.0551	2 7/8	2 5/8	5/8	5/8	6 11/32	5 3/4	.120	5/8-18	40
		166720	230	73.0	66.7	15.9	15.9	161.1	146.1	3.05		18.14

Metric dimensions for reference only.

Not all parts are available from stock. Please contact customer service for availability (800) 626-2120.

For more information on bearing capabilities outside of our standard offering, please contact Application Engineering (800) 626-2093.



Mounted Ball Bearing Engineering see page G-220.

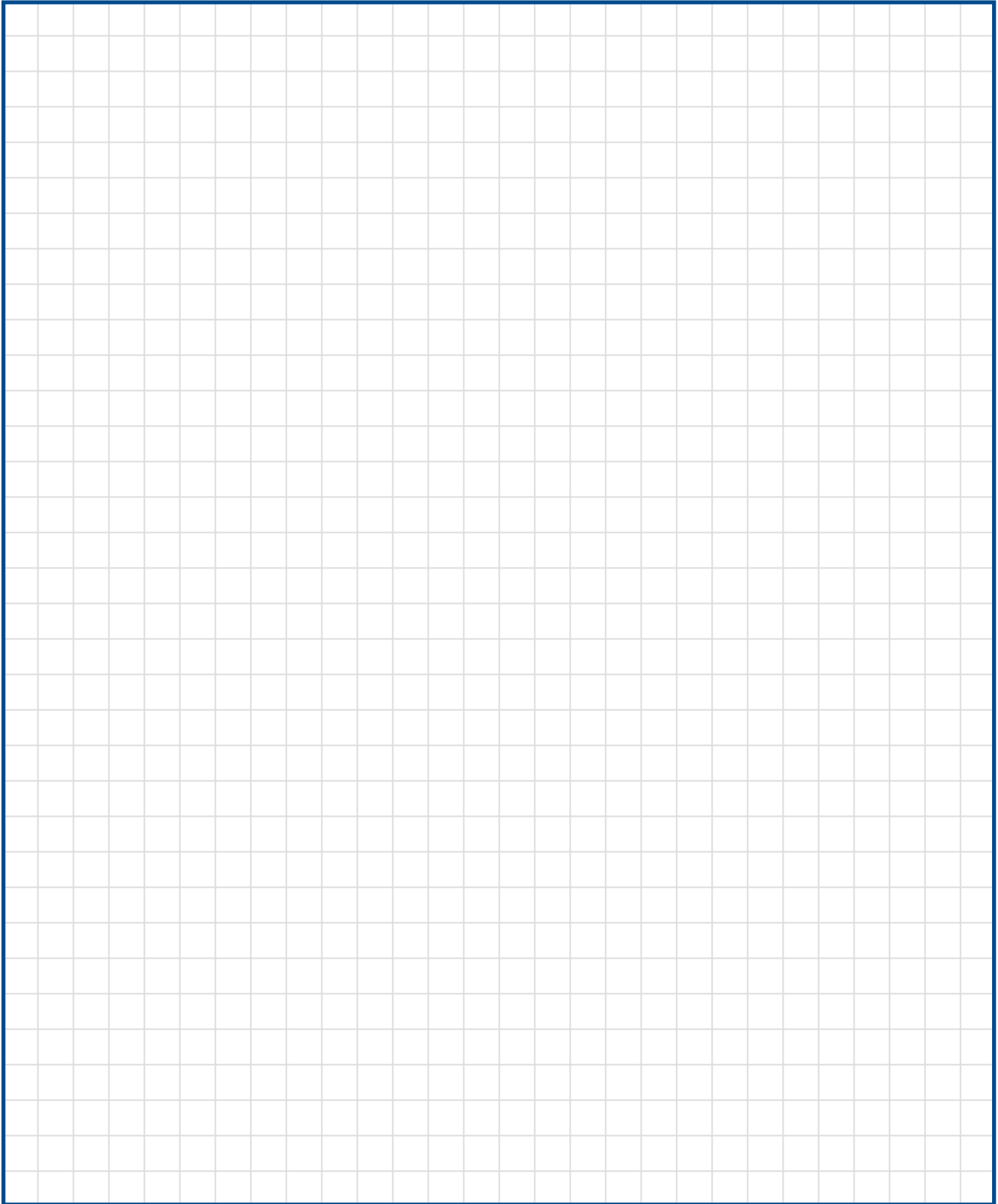

Sealmaster ER Style Ball Bearings

Sealmaster Gold ER bearings feature a cylindrical OD and snap ring for easy installation in a roll assembly. Shaft lock is achieved by either setscrew or Skwezloc® concentric locking collar. The felt seal with flinger provide a good balance between contaminant entry, GoldPlex HP™ grease loss and friction. Depending on your preference, these bearings are available in both inch and metric shaft sizes with a wide variety of sealing and lubrication options or ERX-TREME industry specific solutions as illustrated on the pages to follow.

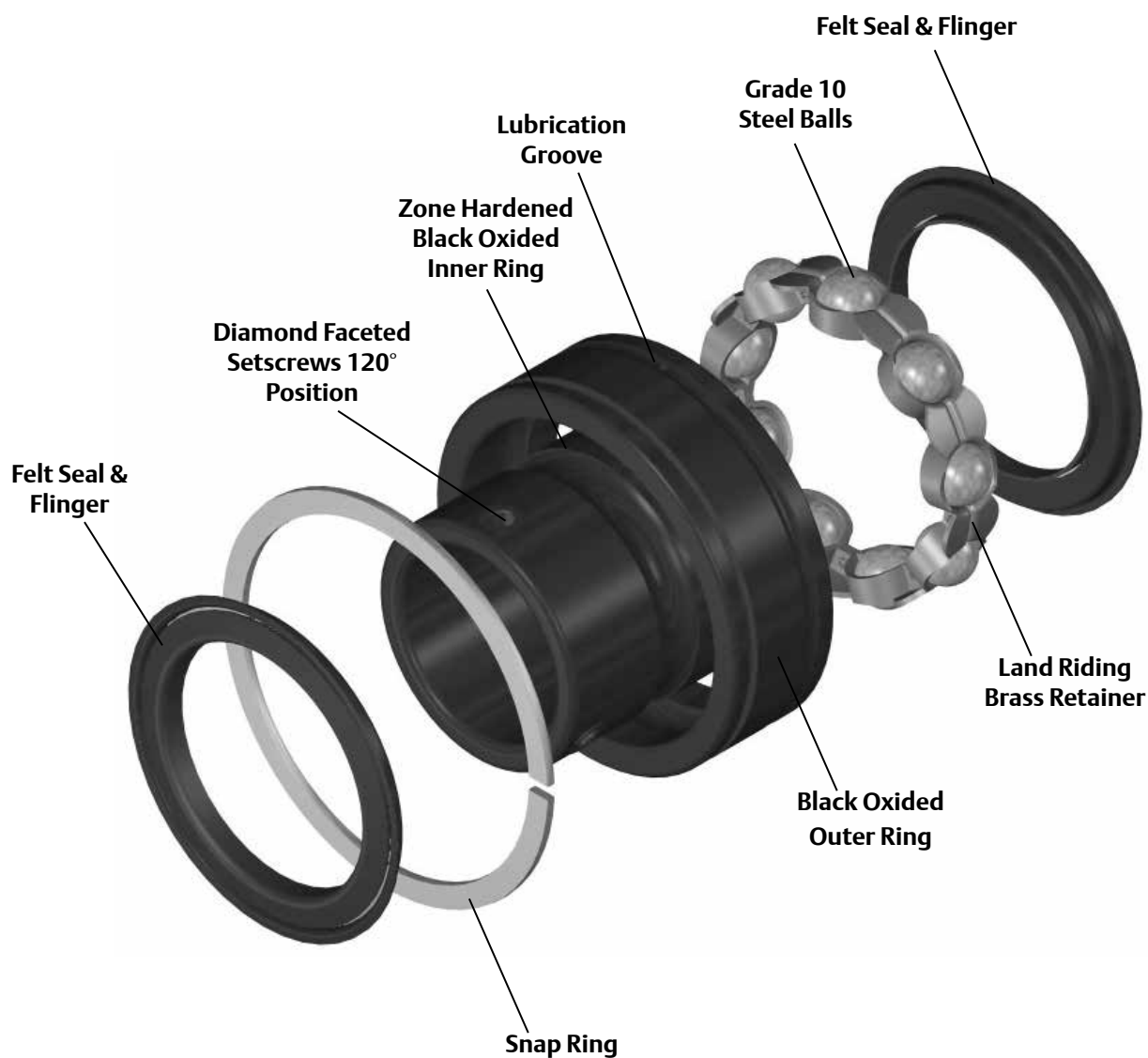



ER Style Nomenclature

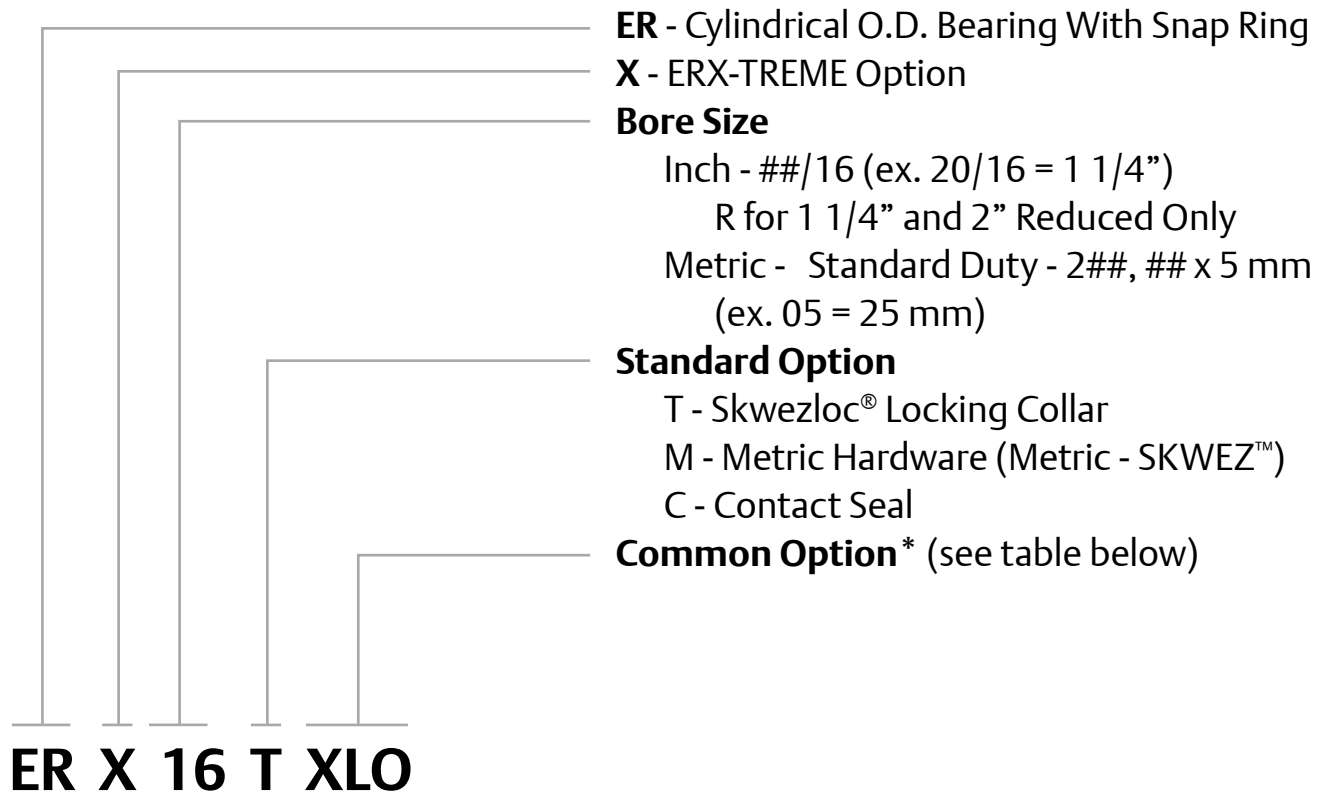

Common Option

- 3C** Triple Lip Contact Seal - replaced by DRT in most sizes
- DRT** High Contamination
- HI** ERX-Treme High Temperature Krytox* Grease
- HIY** ERX-Treme High Temperature Krytox* Grease Expansion
- LO** ERX-Treme Low Drag
- X** Labyrinth Seal
- XLO** ERX-Treme Extra Low Drag



*Note: Configurations are not available in all sizes or housing styles. Consult the product tables, option sections and engineering sections for more detail or consult a Bearing Application Engineer.

**KRYTOX is a registered trademark of E.I. du Pont de Nemurs and Company. This trade name, trademark and/or registered trademark is property of their respective owner and is not owned or controlled by Power Transmission Solutions.



Features and Benefits

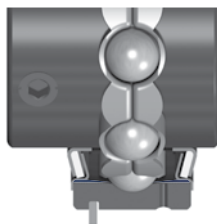

Outer Race With Tapered Lands

The Sealmaster ER Bearings Outer Ring is black oxidized and comes standard with a locating ring and lubrication groove and lubrication inlet. In addition, they have the Sealmaster patented Tapered Lands bearing race profile which means that critical lubricant is circulated more efficiently, while requiring no regular service intervals. The outer land surface in a conventional bearing is parallel to the axis of the inner ring. The Tapered Lands surface is tapered in a radial direction toward the bearing race. This subtle yet crucial design change allows lubricant to more easily flow back to the raceway. With improved bearing lubricant circulation comes significantly longer bearing service life. This improved circulation and service life comes without any reductions in bearing radial or thrust capacities.

* For bearings that are maintained and relubricated on a regular basis, there is no significant difference in expected life.



Multiple Sealing Options Felt Seal With Flinger

The standard felt seal provides a tight labyrinth seal which retains lubrication and acts as a filter to exclude contamination. The external stamping is a flinger which shields the felt from large contaminants and directs them away from the sealing surface. The design operates with less drag and less heat generation than rubber contact seals.



Single Lip Contact Seal

Single Lip Contact Seal consists of a nitrile rubber washer in metal shroud to shield the lip from large contaminants. The seal is designed to balance drag and protection in wet and dry environments. This can be specified by adding the suffix C to the part number.

Additional Sealing Options can be found on pages G-103 to G-106.



Features and Benefits continued

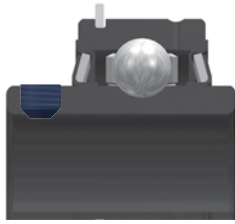

Multiple Locking Methods Setscrew Locking

120° spaced, balanced three point contact minimizes inner ring distortion vibration, reduces noise, and improves reliability. Precision manufactured diamond faceted setscrews contribute to improved clamping and resistance to back out.

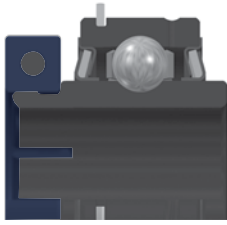

Sealmaster Skwezloc® Concentric Locking Collar

SKWEZLOC is a concentric locking collar clamp design that results in near-perfect concentricity of the shaft to the bearing bore and maintains near perfect ball path roundness, while reducing fretting corrosion. This design eliminates the shaft damage of setscrew locking, and minimizes bearing induced vibration for smoother quieter operation. The collar has a TORX head cap screw that outlasts stripping 12 times longer than hex head cap screws.



Zone Hardened Inner Race

Sealmaster incorporates a unique heat treat process that hardens the inner race only where it is needed...under the ball path. The black oxidized zone hardened inner race results in improved lock reliability as a result of less distortion at the setscrew location and improved thread conformity resulting in improved clamping and resistance to setscrew back-out.



Land Riding Retainer

The Sealmaster unique land riding metal retainer design provides superior pocket clearance allows for 360° oil circulation around the rolling elements resulting in better retained and utilized lubrication.

Options

Bearings are typically selected using L10 fatigue life calculations based on ideal operating conditions. However, most bearing problems are not fatigue related, but occur due to contamination, lubrication starvation, or other environmental issues. As a result our Bearing engineers have developed custom solutions to meet the varying severity, operating parameters and maintenance regularity, such as ERX-TREME and Custom Select.

ERX-TREME Options

Low Drag

Suffix	Description	Temperature	Environment	Speed Limits
LO	Low Drag	-20°F to 180°F	Dry/Dusty	Pages G-235 to G-240
XLO	Extra Low Drag	-20°F to 100°F		

ERX-TREME Low Drag “LO”

- Felt seal cut down to reduce drag
- Provides excellent barrier that works to retain grease and acts as a filter to reduce the ingress of debris contaminants
- Features a channeling grease that reduces drag while lubricating the bearing

ERX-TREME X-Tra Low Drag “XLO”

- Felt seal cut down and oil soaked for extra low drag
- Oil lubricated

Bearing Rotational Torque - Comparison Chart

	Company	Suffix Option	Seal Type	Lubrication
LO Drag Bearing Options	AMI®	FS	Non-Contact	Oil
	Sealmaster	XLO	Low Drag Felt	Oil
	MB®	HFF	Steel Labyrinth	Oil
	Peer®	ZSFF	Steel Labyrinth	Oil
	Sealmaster	LO	Low Drag Felt	Grease
	MB	MHFF	Steel Labyrinth	Grease
	FYH®	DSK3	Non-Contact	Oil
	Peer	ZMKFF	Steel Labyrinth	Grease
Standard Bearing Drag (Reference)	Sealmaster	-	Felt	Grease
	Sealmaster	C	Contact	Grease

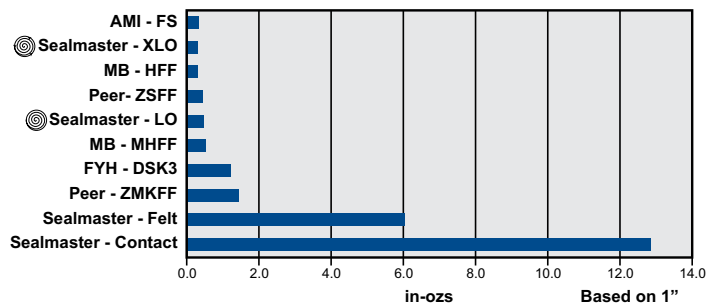

* The following trade names, trademarks and/or registered trademarks that follow are used in this material by Emerson for comparison purposes only, are NOT owned or controlled by Emerson and are believed to be owned by the following parties: Dodge: Baldor Electric Company; AMI: Asahi Tec Corp. of Japan; MB: Rexnord Industries, Inc.; Peer: Peer Bearing Company; FYH: Nippon Pillow Block Co., Ltd. Fafnir: Timken US Corporation. Emerson cannot and does not represent or warrant the accuracy of this information.



ERX-TREME Options continued

High Temperature

Suffix	Description	Temperature	Environment	Speed Limits
HI*	High Performance High Temp	200°F to 400°F	Dry/Dusty	Pages G-235 to G-240
HIY				



ERX-TREME High Temperature "HI"

- High temperature bearing with increased internal clearance to accommodate thermal expansion of components
- High temperature Nomex seal* and Krytox*-226 grease



ERX-TREME Expansion - High Temperature "HIY"

- Expansion type HI Temperature utilizes a half-dog setscrew combined with a lock wire and is recommended for applications that require expansion capability.
- High temperature bearing with increased radial internal clearance to accommodate thermal expansion of components
- High temperature Nomex seal and Krytox*-226 grease
- Specify as ERX-xx HIY

This may be essential when shafts grow in length due to temperature changes. The single half-dog setscrew has a cylindrical nub that protrudes out of the bottom of the setscrew. The nub is used to mate loosely with a slot milled into the shafting. As the shaft spins, the nub interferes with the slot and positively turns the inner ring. See HIY installation instructions.

Note: All expansion bearings must be used in conjunction with a fixed bearing to stabilize the system.

KRYTOX Extended Lube Grease

- Used in HI and HIY suffix modified bearings
- KRYTOX GPL 226, an extremely high performance perfluorinated oil and PTFE thickened grease
- KRYTOX grease has a superior service life and therefore diminishes re-lubrication frequency and extends life
- Engineers have found that, compared to other high temperature greases, the thermal stability and lubricity of the KRYTOX can improve high temperature bearing life by a factor of 4 to 45 times

* The following trade names, trademarks and/or registered trademarks are used in this material by Emerson Power Transmission Corporation are NOT owned or controlled by Emerson Power Transmission Corporation and are believed to be owned by the following parties: NOMEX and Krytox: El du Pont de Nemurs and Company. Emerson Power Transmission Corporation cannot and does not represent or warrant the accuracy of this information.



Custom Select

High Contamination

Suffix	Description	Temperature	Environment	Speed Limits
DRT	Highly Contaminated	-20°F to 200°F	Highly Contaminated	Pages G-235 to G-240



2C Seal



3C Seal

High Contamination “DRT”

Heavy Duty Multi-Lip contact seal (depending on size and series, either supplied with “2C” double lip or “3C” triple lip seal), 100% Grease Fill with Sealmaster GoldPlex HP Grease.



Options Availability*

ERX-TREME Options										ER Custom Select Option		
Bore Diameter		Nomenclature Size	Low Drag "LO"		X-Tra Low Drag "XLO"		High Temp. "HI"		High Temp. Exp. "HIY"		High Contamination "DRT"	
inch	mm											
1/2		8	O		O		O					
5/8		10	O		O		O					
11/16		11	O		O							
3/4		12	O	X	O		O	X	O			
	20	204	O	X	O	X		X				
7/8		14	O		O		O		O			
15/16		15	O		O		O		O			
1		16	O	X	O	X	O	X	O		O	X
	25	205	O	X	O	X	O				O	
1 1/8		18	O	X	O	X	O		O			
1 3/16		19	O	X	O	X	O		O			
1 1/4R		20R	O	X	O	X	O		O			
	30	206	O	X	O	X					O	X
1 1/4		20	O	X	O	X	O	X	O		O	
1 5/16		21	O									
1 3/16		22	O	X	O	X	O		O			
1 7/16		23	O	X	O	X	O		O		O	X
	35	207	O	X	O	X	O	X				
1 8/16		24	O	X	O	X	O	X	O		O	
1 9/16		25	O		O		O		O		O	
	40	208	O	X	O	X	O		O			
1 5/8		26		X	O		O				O	
1 11/16		27			O		O		O			
1 3/4		28	O	X	O	X	O		O		O	X
	45	209	O	X	O	X						
1 7/8		30	O				O		O		O	
1 15/16		31	O	X	O	X	O	X	O		O	X
2		32	O	X	O	X	O		O		O	
	50	210	O	X	O	X	O					
2 1/8		34	O									
2 3/16		35	O	X	O	X	O		O		O	X
2 1/4		36	O	X	O		O		O			
2 3/8		38			O		O		O			
2 7/16		39	O	X	O	X	O	X	O		O	X
	60	212					O					
2 1/2		40					O		O			
2 11/16		43					O		O		O	
	70	214										
2 15/16		47	O	X	O	X	O		O		O	
3		48					O		O			
3 3/16		51					O		O		O	
3 1/4		52					O					
3 7/16		55					O		O			
3 15/16		63					O					
4		64					O					

O Setscrew

X Skwezloc Locking Collar

* Sizes and configurations listed in table are subject to change without notice.

For sizes or configurations not listed, contact Bearing Technical Customer Service.



- Duty:** Standard
- Rolling Elements:** Ball
- Housing:** Cylindrical OD Insert
- Lock:** Setscrew
- Seal:** Felt
- Optional Seal:** Contact
- Temperature:** -20° to 220°F
- Relube:** Relube Through Outer Ring Groove

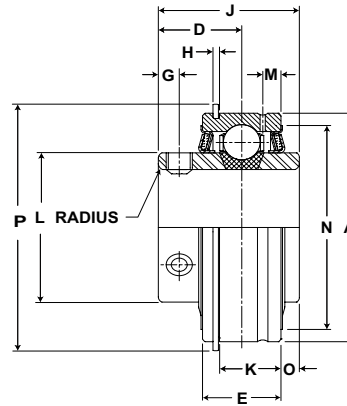

ER Cylindrical O.D. Bearing Insert - Setscrew Locking

Bore Diameter		Bearing Insert No.	Basic Dynamic Rating lb/N	Dimensions inch / mm												Max. Rad. To Clear	Unit Wt. lb/kg
inch	mm			A	D	E	G	H	J	K	L	M	N	O	P		
1/2 9/16 5/8 11/16 3/4	20	ER-8 ER-9 ER-10 ER-11 ER-12 ER-204	2611 11614	1.8504 47	13/16 20.6	5/8 15.9	3/16 4.8	3/64 1.2	1 7/32 31.0	31/64 12.3	1 3/16 30.2	11/64 4.4	1 5/8 41.3	.094 2.39	2 1/16 52.4	.040 1.02	.56 .25
7/8 15/16 1	25	ER-14 ER-15 ER-16 ER-205	2801 12459	2.0472 52	55/64 21.8	3/4 19.1	7/32 5.6	3/64 1.2	1 3/8 34.9	39/64 15.5	1 3/8 34.9	13/64 5.2	1 55/64 47.2	.135 3.43	2 17/64 57.5	.040 1.02	.68 .31
1 1/16 1 1/8 1 3/16 1 1/4	30	ER-17 ER-18 ER-19 ER-20R ER-206	4381 19487	2.4409 62	7/8 22.2	7/8 22.2	7/32 5.6	1/16 1.6	1 1/2 38.1	11/16 17.5	1 19/32 40.5	7/32 5.6	2 5/32 54.8	.188 4.78	2 21/32 67.5	.040 1.02	.93 .42
1 1/4 1 5/16 1 3/8 1 7/16	35	ER-20 ER-21 ER-22 ER-23 ER-207	5782 25718	2.8364 72	1 25.4	15/16 23.8	1/4 6.4	1/16 1.6	1 11/16 42.9	3/4 19.1	1 55/64 47.2	7/32 5.6	2 17/32 64.3	.219 5.56	3 5/64 78.2	.040 1.02	1.37 .62
1 1/2 1 9/16	40	ER-24 ER-25 ER-208	5307 23606	3.1496 80	1 3/16 30.2	1 3/32 27.8	5/16 7.9	1/16 1.6	1 15/16 49.2	29/32 23.0	2 1/16 52.4	1/4 6.4	2 53/64 71.8	.203 5.16	3 13/32 86.5	.062 1.57	2 .91
1 5/8 1 11/16 1 3/4	45	ER-26 ER-27 ER-28 ER-209	7901 35144	3.3465 85	1 3/16 30.2	1 3/32 27.8	5/16 7.9	1/16 1.6	1 15/16 49.2	29/32 23.0	2 19/64 58.3	1/4 6.4	3 1/16 77.8	.203 5.16	3 19/32 91.3	.062 1.57	2.31 1.05
1 13/16 1 7/8 1 15/16 2	50	ER-29 ER-30 ER-31 ER-32R ER-210	7889 35090	3.5433 90	1 9/32 32.5	1 1/8 28.6	3/8 9.5	3/32 2.4	2 1/32 51.6	29/32 23.0	2 15/32 62.7	19/64 7.5	3 7/32 81.8	.188 4.78	3 25/32 96.0	.062 1.57	2.43 1.10
2 2 1/8 2 3/16	55	ER-32 ER-34 ER-35 ER-211	9752 43377	3.9370 100	1 5/16 33.3	1 3/16 30.2	3/8 9.5	3/32 2.4	2 3/16 55.6	31/32 24.6	2 23/32 69.1	19/64 7.5	3 9/16 90.5	.281 7.14	4 3/16 106.4	.080 2.03	3 1.36
2 1/4 2 3/8 2 7/16	60	ER-36 ER-38 ER-39 ER-212	11789 52437	4.3307 110	1 9/16 39.7	1 1/4 31.8	7/16 11.1	3/32 2.4	2 9/16 65.1	1 1/32 26.2	2 63/64 75.8	19/64 7.5	3 29/32 99.2	.375 9.53	4 37/64 116.3	.080 2.03	4 1.81
2 1/2 2 11/16	70	ER-40 ER-43 ER-214	13971 62143	4.9213 125	1 11/16 42.9	1 3/8 34.9	7/16 11.1	7/64 2.8	2 3/4 69.9	1 7/64 28.2	3 7/16 87.3	5/16 7.9	4 7/16 112.7	.375 9.53	5 9/32 134.1	.080 2.03	5.56 2.52
2 7/8 2 15/16	75	ER-46 ER-47 ER-215	14839 66004	5.1181 130	1 3/4 44.5	1 1/2 38.1	7/16 11.1	7/64 2.8	3 1/16 77.8	1 15/16 31.5	1 15/64 92.5	3/8 9.5	4 5/8 117.5	.563 14.30	5 7/16 138.1	.080 2.03	6.37 2.89
3 3 3/16	80	ER-48 ER-51 ER-216	17412 77449	5.5118 140	1 15/16 49.2	1 11/16 42.9	17/32 13.5	7/64 2.8	3 1/4 82.6	1 25/64 35.3	3 59/64 99.6	7/16 11.1	4 63/64 126.6	.469 11.91	5 13/16 147.6	.120 3.05	7.85 3.56
3 1/4 3 3/8 3 7/16		ER-52 ER-54 ER-55	18681 83093	5.9055 150	2 1/32 51.6	1 15/16 49.2	15/32 11.9	7/64 2.8	3 3/8 85.7	1 41/64 41.7	4 5/32 105.6	7/16 11.1	5 19/64 134.5	.375 9.53	6 9/32 159.5	.120 3.05	9.5 4.31
3 15/16 4		ER-63 ER-64	29905 133017	7.4803 190	2 11/16 68.3	2 1/2 63.5	3/4 19.1	1/8 3.2	4 5/8 117.5	2 5/32 54.8	5 11/64 131.4	11/16 17.5	6 21/32 169.1	.688 17.48	8 203.2	.120 3.05	22 9.98

For Housing fit guidelines see page G-259.
Felt seal standard. For contact seal add suffix "C" ER-16C.

Outside diameter may be oversized due to seal press fit.
Metric dimensions for reference only.
Not all parts are available from stock. Please contact customer service for availability (800) 626-2120.
For more information on bearing capabilities outside of our standard offering, please contact Application Engineering (800) 626-2093.

Performance Cylindrical OD Bearings (ER)

SEALMASTER®

Mkt. Ball Bearings



- Duty:** Standard
- Rolling Elements:** Ball
- Housing:** Cylindrical OD Insert
- Lock:** SKWEZLOC Locking Collar
- Seal:** Felt
- Optional Seal:** Contact
- Temperature:** -20° to 220°F
- Relube:** Relube Through Outer Ring Groove

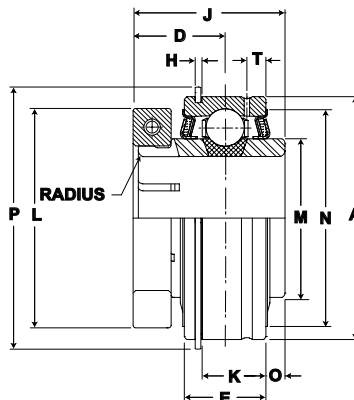

ER-T Cylindrical O.D. Bearing - SKWEZLOC Locking Collar - Inch

Bore Diameter inch	Bearing Insert No.	Basic Dynamic Rating lb/N	Dimensions inch / mm												Max. Rad. To Clear	Unit Wt. lb/kg
			A	D	E	H	J	K	L	M	N	O	P	T		
3/4	ER-12T	2611 11614	1.8504 47.0	7/8 19.8	5/8 15.9	3/64 1.2	1 9/32 32.5	31/64 12.3	1 3/4 44.5	1 3/16 30.2	1 5/8 41.3	.094 2.39	2 1/16 52.4	1/8 3.2	.04 1.02	.25 .56
1	ER-16T	2801 12459	2.0472 52.0	59/64 22.1	3/4 19.1	3/64 1.2	1 7/16 36.5	39/64 15.5	1 15/16 49.2	1 3/8 34.9	1 27/32 46.8	.135 3.43	2 17/64 57.5	13/64 5.2	.04 1.02	.68 .31
1 1/8 1 3/16 1 1/4	ER-18T ER-19T ER-20RT	4381 19487	2.4409 62.0	15/16 23.8	7/8 22.2	1/16 1.6	1 9/16 39.7	11/16 17.5	2 3/16 55.6	1 19/32 40.5	2 5/32 54.8	.188 4.78	2 21/32 67.5	7/32 5.6	.04 1.02	.93 .42
1 1/4	ER-20T	5782 25718	2.8346 72.0	1 1/16 27.0	15/16 23.8	1/16 1.6	1 3/4 44.5	3/4 19.1	2 7/16 61.9	1 55/64 47.2	2 17/32 64.3	.219 5.56	3 5/64 78.2	7/32 5.6	.04 1.02	1.37 .62
1 3/8 1 7/16	ER-22T ER-23T	5782 25718	2.8346 72.0	1 1/16 27.0	15/16 23.8	1/16 1.6	1 3/4 44.5	3/4 19.1	2 9/16 65.1	1 55/64 47.2	2 17/32 64.3	.219 5.56	3 5/64 78.2	7/32 5.6	.04 1.02	1.37 .62
1 1/2	ER-24T	7340 32648	3.1496 80.0	1 1/4 31.8	1 3/32 27.8	1/16 1.6	2 50.8	29/32 23.0	2 11/16 68.3	2 1/16 52.4	2 53/64 71.8	.203 5.16	3 13/32 86.5	1/4 6.4	.06 1.57	2.00 .91
1 5/8	ER-26T	7901 35144	3.3465 85.0	1 1/4 31.8	1 3/32 27.8	1/16 1.6	2 50.8	29/32 23.0	2 13/16 71.4	2 19/64 58.3	3 1/32 77.0	.203 5.16	3 19/32 91.3	1/4 6.4	.06 1.57	2.31 1.05
1 11/16 1 3/4	ER-27T ER-28T	7901 35144	3.3465 85.0	1 1/4 31.8	1 3/32 27.8	1/16 1.6	2 50.8	29/32 23.0	2 15/16 74.6	2 19/64 58.3	3 1/32 77.0	.203 5.16	3 19/32 91.3	1/4 6.4	.06 1.57	2.31 1.05
1 15/16	ER-31T	7889 35090	3.5433 90.0	1 11/32 34.1	1 1/8 28.6	3/32 2.4	2 3/32 53.2	29/32 23.0	3 3/8 85.7	2 15/32 62.7	3 7/32 81.8	.188 4.78	3 25/32 96.0	19/64 7.5	.06 1.57	2.43 1.10
2	ER-32T	9752 43377	3.9370 100.0	1 3/8 34.9	1 3/16 30.2	3/32 2.4	2 1/4 57.2	31/32 24.6	3 1/2 88.9	2 23/32 69.1	3 9/16 90.5	.281 7.14	4 3/16 106.4	19/64 7.5	.08 2.03	3.00 1.36
2 3/16	ER-35T	9752 43377	3.9370 100.0	1 3/8 34.9	1 3/16 30.2	3/32 2.4	2 1/4 57.2	31/32 24.6	3 5/8 92.1	2 23/32 69.1	3 9/16 90.5	.281 7.14	4 3/16 106.4	19/64 7.5	.08 2.03	3.00 1.36
2 1/4	ER-36T	11789 52437	4.3307 110.0	1 5/8 41.3	1 1/4 31.8	3/32 2.4	2 5/8 66.7	1 1/32 26.2	4 1/16 103.2	2 63/64 75.8	3 29/32 99.2	.375 9.53	4 37/64 116.3	19/64 7.5	.08 2.03	4.00 1.81
2 3/8 2 7/16	ER-38T ER-39T	11789 52437	4.3307 110.0	1 5/8 41.3	1 1/4 31.8	3/32 2.4	2 5/8 66.7	1 1/32 26.2	4 1/8 104.8	2 63/64 75.8	3 29/32 99.2	.375 9.53	4 37/64 116.3	19/64 7.5	.08 2.03	4.00 1.81

ER-T Cylindrical O.D. Bearing - SKWEZLOC Locking Collar - Metric - SKWEZ™

Bore Diameter mm	Bearing Insert No.	Basic Dynamic Rating N/lb	Dimensions mm / inch												Max. Rad. To Clear	Unit Wt. kg/lb
			A	D	E	L	H	J	K	M	N	O	P	T		
20	ER-204TMC	11614 2611	47.0 1.8504	19.8 7/8	15.9 5/8	44.5 1 3/4	1.2 3/64	32.5 1 9/32	12.3 31/64	30.2 1 3/16	41.3 1 5/8	2.39 .094	52.4 2 1/16	3.2 1/8	1.02 .04	.25 .56
25	ER-205TMC	12459 2801	52.0 2.0472	22.1 59/64	19.1 3/4	49.2 1 15/16	1.2 3/64	36.5 1 7/16	15.5 39/64	34.9 1 3/8	46.8 1 27/32	.135 .343	57.5 2 17/64	5.2 13/64	.04 1.02	.31 .68
30	ER-206TMC	19487 4381	62.0 2.4409	23.8 15/16	22.2 7/8	55.6 2 3/16	1.6 1/16	39.7 1 9/16	17.5 11/16	40.5 1 19/32	54.8 2 5/32	4.75 .187	67.5 2 21/32	5.6 7/32	1.02 .04	.42 .93
35	ER-207TMC	25718 5782	72.0 2.8346	27.0 1 1/16	23.8 15/16	65.1 2 9/16	1.6 1/16	44.5 1 3/4	19.1 3/4	47.2 1 55/64	64.3 2 17/32	5.56 .219	78.2 3 5/64	5.6 7/32	1.02 .04	.62 1.37
40	ER-208TMC	32648 7340	80.0 3.1496	31.8 1 1/4	27.8 1 3/32	68.3 2 11/16	1.6 1/16	50.8 2	23.0 29/32	52.4 2 1/16	71.8 2 53/64	4.76 .188	86.5 3 13/32	6.4 1/4	1.57 .06	.91 2.00
45	ER-209TMC	35144 7901	85.0 3.3465	31.8 1 1/4	27.8 1 3/32	74.6 2 15/16	1.6 1/16	50.8 2	23.0 29/32	58.3 2 19/64	77.0 3 1/32	4.76 .188	91.3 3 19/32	6.4 1/4	1.57 .06	1.05 2.31
50	ER-210TMC	35090 7889	90.0 3.5433	34.1 1 11/32	28.6 1 1/8	85.7 3 3/8	2.4 3/32	53.2 2 3/32	23.0 29/32	62.7 2 15/32	81.8 3 7/32	4.78 .188	96.0 3 25/32	7.5 19/64	1.57 .06	1.10 2.43
55	ER-211TMC	43377 9752	100.0 3.9370	34.9 1 3/8	30.2 1 3/16	92.1 3 5/8	2.4 3/32	57.2 2 1/4	24.6 31/32	69.1 2 23/32	90.5 3 9/16	7.14 .281	106.4 4 3/16	7.5 19/64	2.03 .08	1.36 3.00
60	ER-212TMC	52437 11789	110.0 4.3307	41.3 1 5/8	31.8 1 1/4	104.8 4 1/8	2.4 3/32	66.7 2 5/8	26.2 1 1/32	75.8 2 63/64	99.2 3 29/32	9.53 .375	116.3 4 37/64	7.5 19/64	2.03 .08	1.81 4.00

For Housing fit guidelines see page G-259.

Sealmaster Material Handling Mounted Ball Bearings

Sealmaster material handling mounted ball bearings feature cast iron housings, an extended inner race insert bearing with ball riding nylon retainer. The insert features a rivet to prevent outer ring rotation and is available with setscrew or SKWEZLOC® concentric locking collar and optional snap on end cover. The contact seal, with black oxide treated flinger provides a good balance between contaminant resistance, grease loss and friction. Depending on your preference, these bearings are available in common unit material handling industry bore sizes and housing configurations as illustrated on the pages to follow.

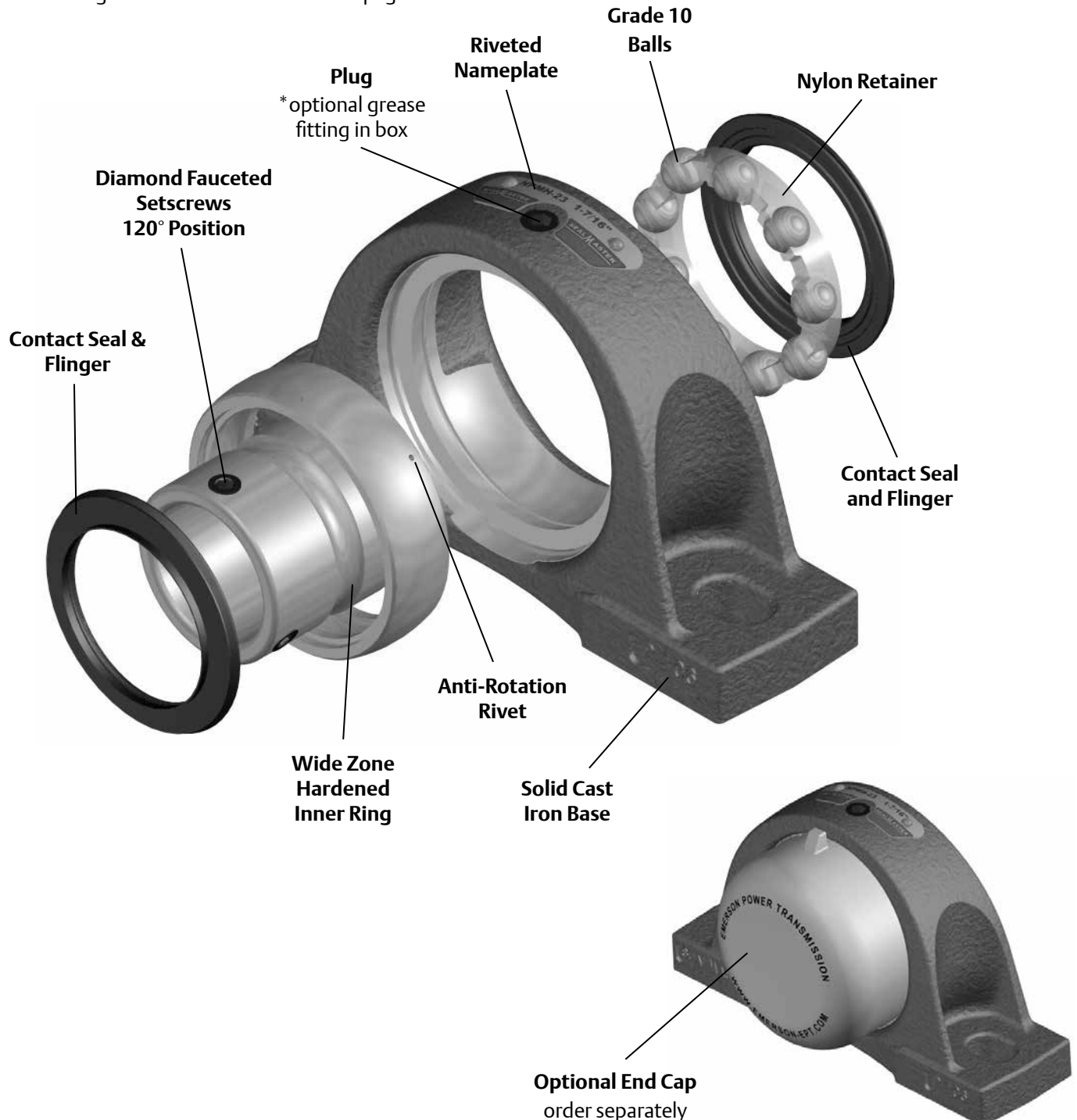



Material Handling Mounted Ball Nomenclature Housing Units

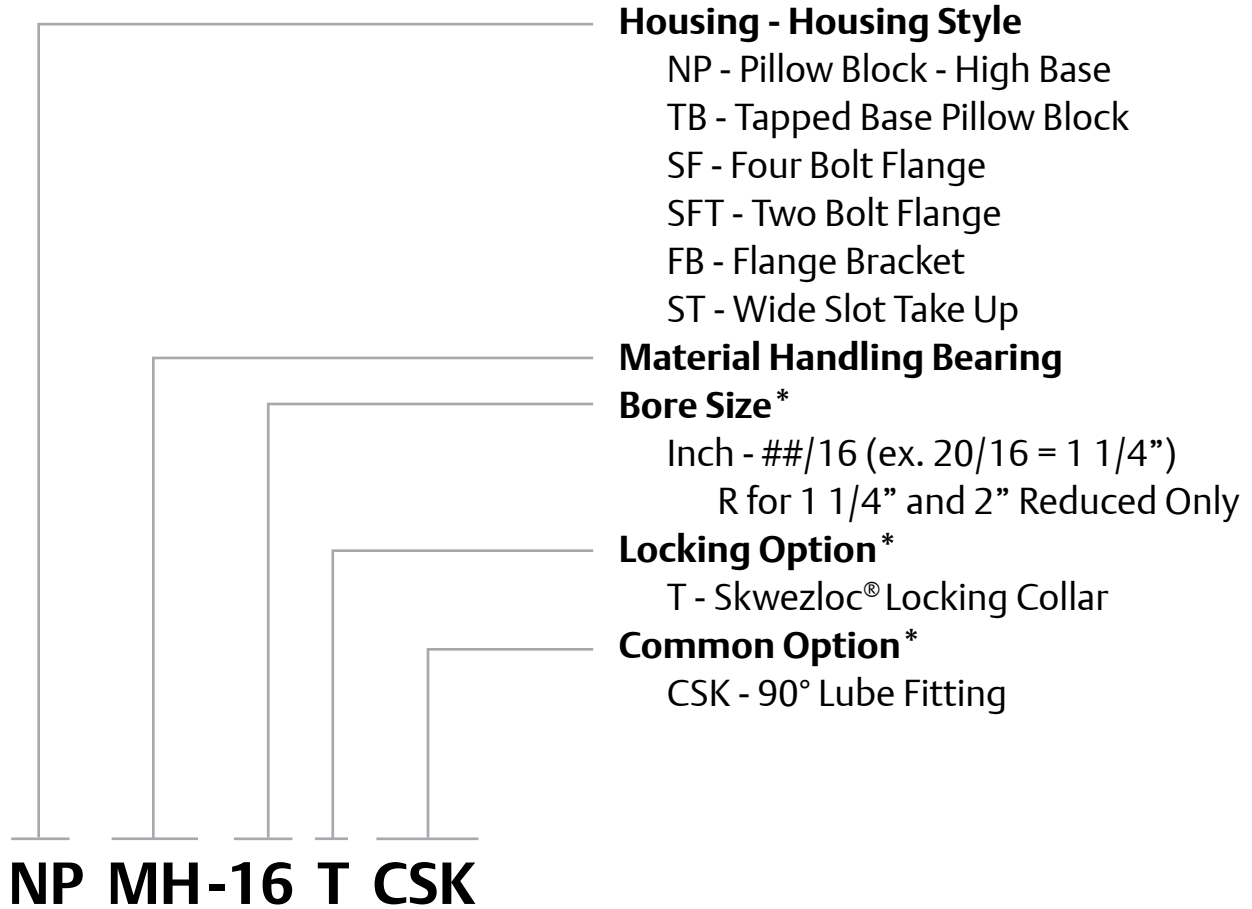

Inserts

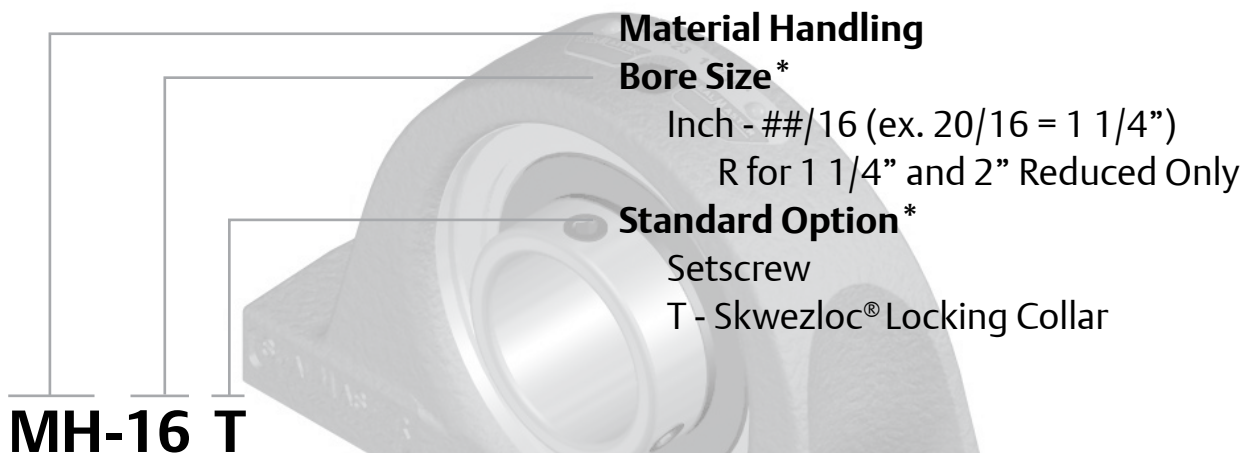

*Note: Configurations are not available in all sizes or housing styles. Consult the product tables and engineering sections for more detail or consult a Bearing Application Engineer.



Features and Benefits

Multiple Locking Methods

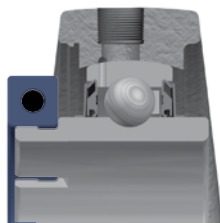

Skwezloc® Concentric Locking Collar

SKWEZLOC is a concentric locking collar clamp design that results in near-perfect concentricity of the shaft to the bearing bore and maintains near perfect ball path roundness, while reducing fretting corrosion. This design eliminates the shaft damage of setscrew locking, and minimizes bearing induced vibration for smoother quieter operation. The collar has a TORX head cap screw that outlasts stripping 12 times longer than hex head cap screws.

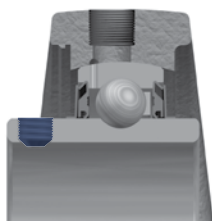

Setscrew Locking

120° spaced, balanced three point contact minimizes inner ring distortion vibration, reduces noise, and improves reliability. Precision manufactured diamond faceted setscrews contributes to improved clamping and resistance to back out.



Sealing

Positive contact molded nitrile rubber contact seal with an auxiliary flinger element standard. The contact seal allows grease purge and helps keep contamination out of the bearing while the flinger provides a rotating shield that directs contamination away from the seal.

Sealed for Life

The Sealmaster Material Handling Bearings are supplied with a plug in the housing to prevent relubrication. A standard lubrication fitting is supplied loose in the box for those customers who prefer relubricating the bearings.



End Caps

The Sealmaster Material Handling Bearings housing are machined to accept an optional safety yellow polymer snap on end cap to cover rotating shafts, allowing users to better conform to OSHA requirements for personal protection from rotating shafts. The end cap can easily snap into the housing without the need for special tooling.



Features and Benefits continued



Anti-Rotation Rivet

An Anti-rotation rivet prevents outer ring creep, or rotation, within the housing.



Zone Hardened Inner Race

Sealmaster incorporates a unique heat treat process that hardened the inner race only where it is needed...under the ball path. The zone hardened inner race results in improved lock reliability as a result of less distortion at setscrew location and improved thread conformity resulting in improved clamping and resistance to setscrew back-out.



Solid Cast Iron Base

Solid bases are standard on Sealmaster Material Handling ball bearing pillow blocks. The solid base provides improved stability, resistance to shock and vibration and prevents frame buckling under base compared to semi-solid and hollow mounting bases.



Nameplate

Metal nameplate riveted to the housing allows for easy identification even after years of operation.

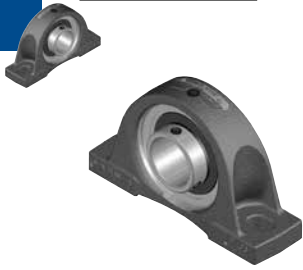

- Duty:** Standard
- Rolling Elements:** Ball
- Housing:** Cast Iron Pillow Block
- Self Alignment:** +/- 1.5 Degrees
- Lock:** Setscrew
- Seal:** Contact Seal and Flinger
- Temperature:** -20° to 200°F
- Relube:** Plugged, Grease Fitting Included

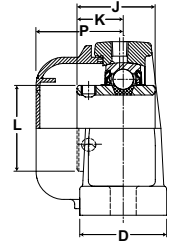
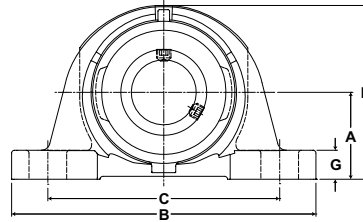

NPMH Series Standard Duty Pillow Block - Setscrew Locking

Bore Diameter inch	Part No.	Bearing Insert No.	Optional End Cap*	Basic Dynamic Rating lb/N	Dimensions inch / mm												Bolt Size	Unit Wt. lb/kg
					A	B	C		D	G	H	J	K	L	P			
							Min.	Max.										
1	NPMH-16	MH-16	ECC-16	2801 12459	1 7/16 36.5	5 1/2 139.7	3 7/8 98.4	4 3/8 111.1	1 1/2 38.1	1/2 12.7	2 13/16 71.4	1 3/8 34.9	13/16 20.6	1 3/8 34.9	1 11/16 42.9	3/8	2.0 .91	
1 3/16 1 1/4	NPMH-19 NPMH-20R	MH-19 MH-20R	ECC-19	4381 19487	1 11/16 42.9	6 1/2 165.1	4 7/16 112.7	5 1/16 128.6	1 7/8 47.6	9/16 14.3	3 3/8 85.7	1 1/2 38.1	7/8 22.2	1 19/32 40.5	1 3/4 44.5	1/2	3.6 1.62	
1 1/4 1 7/16	NPMH-20 NPMH-23	MH-20 MH-23	ECC-23	5782 25718	1 7/8 47.6	6 9/16 166.7	4 11/16 119.1	5 5/16 134.9	1 7/8 47.6	5/8 15.9	3 3/4 95.3	1 11/16 42.9	1 25.4	1 55/64 47.2	1 7/8 47.6	1/2	4.4 1.98	
1 1/2	NPMH-24	MH-24	ECC-24	7340 32648	1 15/16 49.2	7 1/4 184.2	4 7/8 123.8	5 7/8 149.2	2 1/8 54.0	11/16 17.5	3 15/16 100.0	1 15/16 49.2	1 3/16 30.2	2 1/16 52.4	2 1/16 52.4	1/2	5.4 2.45	
1 11/16	NPMH-27	MH-27	ECC-27	7901 35144	2 1/8 54.0	7 1/2 190.5	5 7/16 138.1	6 1/16 154.0	2 1/8 54.0	11/16 17.5	4 1/4 108.0	1 15/16 49.2	1 3/16 30.2	2 19/64 58.3	2 1/6 52.4	1/2	6.1 2.75	
1 15/16	NPMH-31	MH-31	ECC-31	7889 35090	2 1/4 57.2	8 1/8 206.4	6 152.4	6 1/2 165.1	2 3/8 60.3	3/4 19.1	4 9/16 115.9	2 1/32 51.6	1 9/32 32.5	2 15/32 62.7	2 1/16 52.4	5/8	7.4 3.34	
2 2 3/16	NPMH-32 NPMH-35	MH-32 MH-35	ECC-35	9752 43377	2 1/2 63.5	8 5/8 219.1	6 1/2 165.1	7 177.8	2 3/8 60.3	11/16 17.5	4 15/16 125.4	2 3/16 55.6	1 5/16 33.3	2 23/32 69.1	2 15/64 56.8	5/8	9.4 4.24	

*Closed End Cap part number is shown for Open End Cap. See page L-4 in the Accessories section.

Metric dimensions for reference only.

Not all parts are available from stock. Please contact customer service for availability (800) 626-2120.

For more information on bearing capabilities outside of our standard offering, please contact Application Engineering (800) 626-2093.



- Duty:** Standard
- Rolling Elements:** Ball
- Housing:** Cast Iron Pillow Block
- Self Alignment:** +/- 1.5 Degrees
- Lock:** Skwezloc Locking Collar
- Seal:** Contact Seal and Flinger
- Temperature:** -20° to 200°F
- Relube:** Plugged, Grease Fitting Included

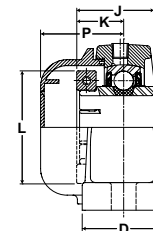
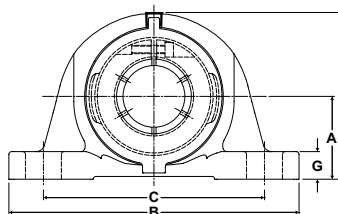

NPMH-T Series Standard Duty Pillow Block - Skwezloc Locking Collar

Bore Diameter inch	Part No.	Bearing Insert No.	Optional End Cap*	Basic Dynamic Rating lb/N	Dimensions inch / mm										Bolt Size	Unit Wt. lb/kg	
					A	B	C		D	G	H	J	K	L			P
							Min.	Max.									
1	NPMH-16T	MH-16T	ECC-16	2801 12459	1 7/16 36.5	5 1/2 139.7	3 7/8 98.4	4 3/8 111.1	1 1/2 38.1	1/2 12.7	2 13/16 71.4	1 7/16 36.5	7/8 22.2	1 15/16 49.2	1 11/16 42.9	3/8	2.1 .96
1 3/16	NPMH-19T	MH-19T	ECC-19	4381	1 11/16	6 1/2	4 7/16	5 1/16	1 7/8	9/16	3 3/8	1 9/16	15/16	2 3/16	1 3/4	1/2	3.8 1.70
1 1/4	NPMH-20RT	MH-20RT	ECC-19	19487	42.9	165.1	112.7	128.6	47.6	14.3	85.7	39.7	23.8	55.6	44.5		
1 1/4	NPMH-20T	MH-20T	ECC-23	5782 25718	1 7/8 47.6	6 9/16 166.7	4 11/16 119.1	5 5/16 134.9	1 7/8 47.6	5/8 15.9	3 3/4 95.3	1 3/4 44.5	1 1/16 27.0	2 7/16 61.9	1 7/8 47.6	1/2	4.6 2.08
1 7/16	NPMH-23T	MH-23T	ECC-23	5782 25718	1 7/8 47.6	6 9/16 166.7	4 11/16 119.1	5 5/16 134.9	1 7/8 47.6	5/8 15.9	3 3/4 95.3	1 3/4 44.5	1 1/16 27.0	2 9/16 65.1	1 7/8 47.6	1/2	4.5 2.02
1 1/2	NPMH-24T	MH-24T	ECC-24	7340 32648	1 15/16 49.2	7 1/4 184.2	4 7/8 123.8	5 7/8 149.2	2 1/8 54.0	11/16 17.5	3 15/16 100.0	2 50.8	1 1/4 31.8	2 11/16 68.3	2 1/6 52.4	1/2	5.7 2.57
1 11/16	NPMH-27T	MH-27T	ECC-27	7901 35144	2 1/8 54.0	7 1/2 190.5	5 7/16 138.1	6 1/16 154.0	2 1/8 54.0	11/16 17.5	4 1/4 108.0	2 50.8	1 1/4 31.8	2 15/16 74.6	2 1/16 52.4	1/2	6.4 2.88
1 15/16	NPMH-31T	MH-31T	ECC-31	7889 35090	2 1/4 57.2	8 1/8 206.4	6 152.4	6 1/2 165.1	2 3/8 60.3	3/4 19.1	4 9/16 115.9	2 3/32 53.2	1 11/32 34.1	3 3/8 85.7	2 1/16 52.4	5/8	8.0 3.62
2	NPMH-32T	MH-32T	ECC-35	9752 43377	2 1/2 63.5	8 5/8 219.1	6 1/2 165.1	7 177.8	2 3/8 60.3	11/16 17.5	4 15/16 125.4	2 1/4 57.2	1 3/8 34.9	3 1/2 88.9	2 15/64 56.8	5/8	9.9 4.50
2 3/16	NPMH-35T	MH-35T	ECC-35	9752 43377	2 1/2 63.5	8 5/8 219.1	6 1/2 165.1	7 177.8	2 3/8 60.3	11/16 17.5	4 15/16 125.4	2 1/4 57.2	1 3/8 34.9	3 5/8 92.1	2 15/64 56.8	5/8	9.6 4.37

*Closed End Cap part number is shown for Open End Cap. See page L-4 in the Accessories section.



Duty: Standard
Rolling Elements: Ball
Housing: Cast Iron Tapped Base
Self Alignment: +/- 1.5 Degrees
Lock: Setscrew
Seal: Contact Seal and Flinger
Temperature: -20° to 200°F
Relube: Plugged, Grease Fitting Included

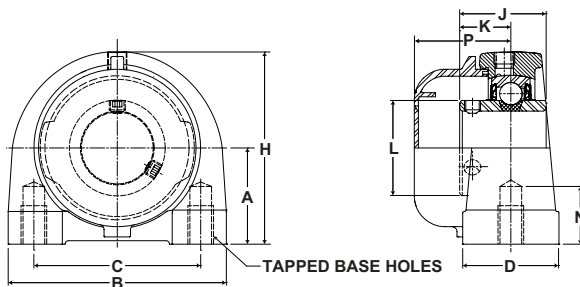

TBMH Series Tapped Base Pillow Block - Setscrew Locking

Bore Diameter inch	Part No.	Bearing Insert No.	Optional End Cap*	Basic Dynamic Rating lb/N	Dimensions inch / mm										Bolt UNC-2B Thread	Unit Wt. lb/kg
					A	B	C	D	H	J	K	L	P	N Min. Tap Depth		
1	TBMH-16	MH-16	ECC-16	2801 12459	1 7/16 36.5	3 76.2	2 50.8	1 1/2 38.1	2 13/16 71.4	1 3/8 34.9	13/16 20.6	1 3/8 34.9	1 3/4 44.5	1/2 12.7	3/8-16	1.6 .72
1 3/16	TBMH-19	MH-19	ECC-19	4381	1 3/4	4	3	1 1/2	3 13/32	1 1/2	7/8	1 19/32	1 49/64	5/8	7/16-14	2.9 1.30
1 1/4	TBMH-20R	MH-20R		19487	44.5	101.6	76.2	38.1	86.5	38.1	22.2	40.5	44.8	15.9		
1 1/4	TBMH-20	MH-20	ECC-23	5782	1 7/8	4 1/4	3 1/4	1 7/8	3 3/4	1 11/16	1	1 55/64	1 7/8	3/4	1/2-13	3.9 1.75
1 7/16	TBMH-23	MH-23	ECC-23	25718	47.6	108.0	82.6	47.6	95.3	42.9	25.4	47.2	47.6	19.1		
1 1/2	TBMH-24	MH-24	ECC-24	7340 32648	1 15/16 49.2	4 5/8 117.5	3 1/2 88.9	1 7/8 47.6	3 15/16 100.0	1 15/16 49.2	1 3/16 30.2	2 1/16 52.4	2 3/32 53.2	3/4 19.1	1/2-13	4.6 2.10
1 11/16	TBMH-27	MH-27	ECC-27	7901 35144	2 1/8 54.0	5 127.0	3 3/4 95.3	2 50.8	4 1/4 108.0	1 15/16 49.2	1 3/16 30.2	2 19/64 58.3	2 5/32 54.8	3/4 19.1	1/2-13	5.7 2.57
1 15/16	TBMH-31	MH-31	ECC-31	7889 35090	2 1/4 57.2	5 1/2 139.7	4 101.6	2 50.8	4 5/8 117.5	2 1/32 51.6	1 9/32 32.5	2 15/32 62.7	2 1/8 53.9	7/8 22.2	5/8-11	6.7 3.05

*Closed End Cap part number is shown for Open End Cap. See page L-4 in the Accessories section.

Metric dimensions for reference only.

Not all parts are available from stock. Please contact customer service for availability (800) 626-2120.

For more information on bearing capabilities outside of our standard offering, please contact Application Engineering (800) 626-2093.



- Duty:** Standard
- Rolling Elements:** Ball
- Housing:** Cast Iron Tapped Base
- Self Alignment:** +/- 1.5 Degrees
- Lock:** Skwezloc Locking Collar
- Seal:** Contact Seal and Flinger
- Temperature:** -20° to 200°F
- Relube:** Plugged, Grease Fitting Included

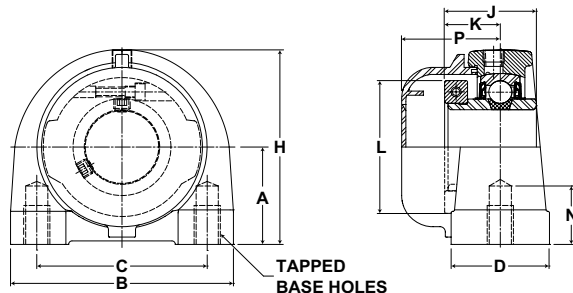

TBMH-T Series Tapped Base Pillow Block - Skwezloc Locking Collar

Bore Diameter inch	Part No.	Bearing Insert No.	Optional End Cap*	Basic Dynamic Rating lb/N	Dimensions inch / mm										N Min. Tap Depth	Bolt UNC-2B Thread	Unit Wt. lb/kg
					A	B	C	D	H	J	K	L	P				
1	TBMH-16T	MH-16T	ECC-16	2801 12459	1 7/16 36.5	3 76.2	2 50.8	1 1/2 38.1	2 13/16 71.4	1 7/16 36.5	7/8 22.2	1 15/16 49.2	1 3/4 44.5	1/2 12.7	3/8-16	1.7 .78	
1 3/16	TBMH-19T	MH-19T	ECC-19	4381	1 3/4	4	3	1 1/2	3 13/32	1 9/16	15/16	2 3/16	1 49/64	5/8	7/16-14	3.0	
1 1/4	TBMH-20RT	MH-20RT		19487	44.5	101.6	76.2	38.1	86.5	39.7	23.8	55.6	44.8	15.9		1.37	
1 1/4	TBMH-20T	MH-20T	ECC-23	5782 25718	1 7/8 47.6	4 1/4 108.0	3 1/4 82.6	1 7/8 47.6	3 3/4 95.3	1 3/4 44.5	1 1/16 27.0	2 7/16 61.9	1 7/8 47.6	3/4 19.1	1/2-13	4.1 1.85	
1 7/16	TBMH-23T	MH-23T	ECC-23	5782 25718	1 7/8 47.6	4 1/4 108.0	3 1/4 82.6	1 7/8 47.6	3 3/4 95.3	1 3/4 44.5	1 1/16 27.0	2 9/16 65.1	1 7/8 47.6	3/4 19.1	1/2-13	3.9 1.79	
1 1/2	TBMH-24T	MH-24T	ECC-24	7340 32648	1 15/16 49.2	4 5/8 117.5	3 1/2 88.9	1 7/8 47.6	3 15/16 100.0	2 50.8	1 1/4 31.8	2 11/16 68.3	2 3/32 53.2	3/4 19.1	1/2-13	4.9 2.22	
1 11/16	TBMH-27T	MH-27T	ECC-27	7901 35144	2 1/8 54.0	5 127.0	3 3/4 95.3	2 50.8	4 1/4 108.0	2 50.8	1 1/4 31.8	2 15/16 74.6	2 5/32 54.8	3/4 19.1	1/2-13	6.0 2.70	
1 15/16	TBMH-31T	MH-31T	ECC-31	7889 35090	2 1/4 57.2	5 1/2 139.7	4 101.6	2 50.8	4 5/8 117.5	2 3/32 53.2	1 11/32 34.1	3 3/8 85.7	2 1/8 53.9	7/8 22.2	5/8-11	7.3 3.32	

*Closed End Cap part number is shown for Open End Cap. See page L-4 in the Accessories section.



- Duty:** Standard
- Rolling Elements:** Ball
- Housing:** Cast Iron Four Bolt Flange
- Self Alignment:** +/- 1.5 Degrees
- Lock:** Setscrew
- Seal:** Contact Seal and Flinger
- Temperature:** -20° to 200°F
- Relube:** Plugged, Grease Fitting Included

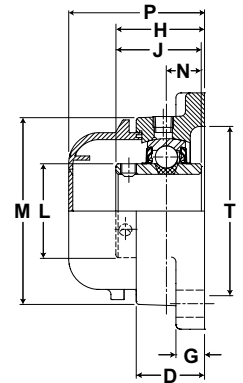
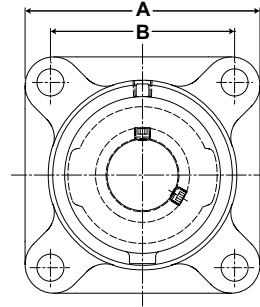

SFMH Series Standard Duty 4-Bolt Flange - Setscrew Locking

Bore Diameter inch	Part No.	Bearing Insert No.	Optional End Cap*	Basic Dynamic Rating lb/N	Dimensions inch / mm										Bolt Size	Unit Wt. lb/kg	
					A	B	D	G	H	J	L	M	N	P			T
1	SFMH-16	MH-16	ECC-16	2801 12459	3 3/4 95.3	2 3/4 69.9	1 1/32 26.2	17/32 13.5	1 7/16 36.5	1 3/8 34.9	1 3/8 34.9	2 23/32 69.1	9/16 14.3	2 19/64 58.3	2 3/8 60.3	7/16	1.9 .87
1 3/16 1 1/4R	SFMH-19 SFMH-20R	MH-19 MH-20R	ECC-19	4381 19487	4 1/4 108.0	3 1/4 82.6	1 11/64 29.8	17/32 13.5	1 9/16 39.7	1 1/2 38.1	1 19/32 40.5	3 7/32 81.8	5/8 15.9	2 27/64 61.5	2 7/8 73.0	7/16	2.7 1.23
1 1/4 1 7/16	SFMH-20 SFMH-23	MH-20 MH-23	ECC-23	5782 25718	4 5/8 117.5	3 5/8 92.1	1 11/32 34.1	9/16 14.3	1 3/4 44.5	1 11/16 42.9	1 55/64 47.2	3 23/32 94.5	11/16 17.5	2 43/64 67.8	3 5/16 84.1	1/2	3.7 1.68
1 1/2	SFMH-24	MH-24	ECC-24	7340 32648	5 1/8 130.2	4 101.6	1 1/2 38.1	9/16 14.3	2 1/64 51.2	1 15/16 49.2	2 1/16 52.4	4 5/64 103.6	3/4 19.1	2 15/16 74.6	3 1/2 88.9	1/2	4.8 2.18
1 11/16	SFMH-27	MH-27	ECC-27	7901 35144	5 3/8 136.5	4 1/8 104.8	1 9/16 39.7	9/16 14.3	2 3/64 52.0	1 15/16 49.2	2 19/64 58.3	4 21/64 109.9	3/4 19.1	3 76.2	3 3/8 85.7	1/2	5.4 2.43
1 15/16	SFMH-31	MH-31	ECC-31	7889 35090	5 5/8 142.9	4 3/8 111.1	1 9/16 39.7	9/16 14.3	2 5/32 54.8	2 1/32 51.6	2 15/32 62.7	4 33/64 114.7	3/4 19.1	2 63/64 75.8	4 101.6	9/16	5.7 2.60
2 2 3/16	SFMH-32 SFMH-35	MH-32 MH-35	ECC-35	9752 43377	6 3/8 161.9	5 1/8 130.2	1 3/4 44.5	13/16 20.6	2 5/16 58.7	2 3/16 55.6	2 23/32 69.1	5 3/16 131.8	7/8 22.2	3 23/64 85.3	4 1/4 108.0	5/8	9.9 4.48
2 7/16	SFMH-39	MH-39	ECC-39	11789 52437	6 7/8 174.6	5 5/8 142.9	1 15/16 49.2	13/16 20.6	2 11/16 68.3	2 34/61 65.0	2 63/64 75.8	5 7/16 138.1	1 25.4	3 45/64 94.1	4 1/4 108.0	5/8	10.6 4.80

*Closed End Cap part number is shown for Open End Cap. See page L-4 in the Accessories section.

Metric dimensions for reference only.

Not all parts are available from stock. Please contact customer service for availability (800) 626-2120.

For more information on bearing capabilities outside of our standard offering, please contact Application Engineering (800) 626-2093.

Material Handling Bearings **SEALMASTER**®

Mtd. Ball Bearings



- Duty:** Standard
- Rolling Elements:** Ball
- Housing:** Cast Iron Four Bolt Flange
- Self Alignment:** +/- 1.5 Degrees
- Lock:** Skwezloc
- Seal:** Contact Seal and Flinger
- Temperature:** -20° to 200°F
- Relube:** Plugged, Grease Fitting Included

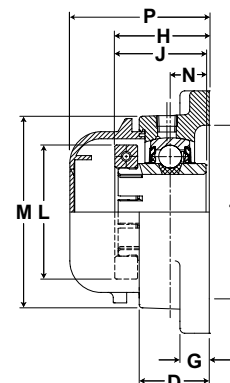
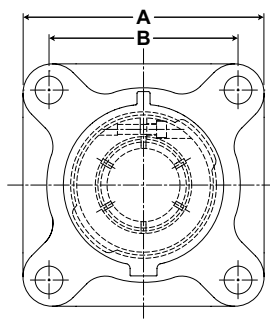

SFMH-T Series Standard Duty 4-Bolt Flange - Skwezloc Locking Collar

Bore Diameter inch	Part No.	Bearing Insert No.	Optional End Cap*	Basic Dynamic Rating lb/N	Dimensions inch / mm										Bolt Size	Unit Wt. lb/kg	
					A	B	D	G	H	J	L	M	N	P			T
1	SFMH-16T	MH-16T	ECC-16	2801 12459	3 3/4 95.3	2 3/4 69.9	1 11/32 26.2	17/32 13.5	1 1/2 38.1	1 7/16 36.5	1 15/16 49.2	2 23/32 69.1	9/16 14.3	2 19/64 58.3	2 3/8 60.3	7/16	2.0 .92
1 3/16 1 1/4R	SFMH-19T SFMH-20RT	MH-19T MH-20RT	ECC-19	4381 19487	4 1/4 108.0	3 1/4 82.6	1 11/64 29.8	17/32 13.5	1 5/8 41.3	1 9/16 39.7	2 3/16 55.6	3 7/32 81.8	5/8 15.9	2 27/64 61.5	2 7/8 73.0	7/16	2.9 1.31
1 1/4	SFMH-20T	MH-20T	ECC-23	5782 25718	4 5/8 117.5	3 5/8 92.1	1 11/32 34.1	9/16 14.3	1 13/16 46.0	1 3/4 44.5	2 7/16 61.9	3 23/32 94.5	11/16 17.5	2 43/64 67.8	3 5/16 84.1	1/2	3.9 1.78
1 7/16	SFMH-23T	MH-23T	ECC-23	5782 25718	4 5/8 117.5	3 5/8 92.1	1 11/32 34.1	9/16 14.3	1 13/16 46.0	1 3/4 44.5	2 9/16 65.1	3 23/32 94.5	11/16 17.5	2 11/16 68.3	3 5/16 84.1	9/16	3.8 1.72
1 1/2	SFMH-24T	MH-24T	ECC-24	7340 32648	5 1/8 130.2	4 101.6	1 1/2 38.1	9/16 14.3	2 5/64 52.8	2 50.8	2 11/16 68.3	4 5/64 103.6	3/4 19.1	2 15/16 74.6	3 1/2 88.9	1/2	5.1 2.30
1 11/16	SFMH-27T	MH-27T	ECC-27	7901 35144	5 3/8 136.5	4 1/8 104.8	1 9/16 39.7	9/16 14.3	2 7/64 53.6	2 50.8	2 15/16 74.6	4 21/64 109.9	3/4 19.1	3 76.2	3 7/8 98.4	1/2	5.7 2.56
1 15/16	SFMH-31T	MH-31T	ECC-31	7889 35090	5 5/8 142.9	4 3/8 111.1	1 9/16 39.7	9/16 14.3	2 7/32 56.4	2 3/32 53.2	3 3/8 85.7	4 33/64 114.7	3/4 19.1	2 63/64 75.8	4 101.6	9/16	6.3 2.88
2	SFMH-32T	MH-32T	ECC-35	9752 43377	6 3/8 161.9	5 1/8 130.2	1 3/4 44.5	13/16 20.6	2 3/8 60.3	2 3/32 53.2	3 1/2 88.9	5 3/16 131.8	7/8 22.2	3 23/64 85.3	4 1/4 108.0	5/8	10.5 4.74
2 3/16	SFMH-35T	MH-35T	ECC-35	9752 43377	6 3/8 161.9	5 1/8 130.2	1 3/4 44.5	13/16 20.6	2 3/8 60.3	2 1/4 57.2	3 5/8 92.1	5 3/16 131.8	7/8 22.2	3 23/64 85.3	4 1/4 108.0	5/8	10.9 4.94
2 7/16	SFMH-39T	MH-39T	ECC-39	11789 52437	6 7/8 174.6	5 5/8 142.9	1 15/16 49.2	13/16 20.6	2 11/16 68.3	2 34/61 65.0	4 1/8 104.8	1 25.4	5 7/16 138.1	3 45/64 94.1	4 1/4 108.0	5/8	11.7 5.32

*Closed End Cap part number is shown for Open End Cap. See page L-4 in the Accessories section.

SEALMASTER® Material Handling Bearings



- Duty:** Standard
- Rolling Elements:** Ball
- Housing:** Cast Iron Two Bolt Flange
- Self Alignment:** +/- 1.5 Degrees
- Lock:** Setscrew
- Seal:** Contact Seal and Flinger
- Temperature:** -20° to 200°F
- Relube:** Plugged, Grease Fitting Included

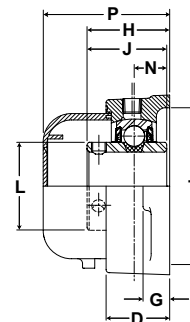
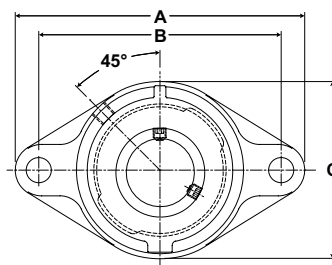

SFTMH Series Standard Duty 2-Bolt Flange - Setscrew Locking

Bore Diameter inch	Part No.	Bearing Insert No.	Optional End Cap*	Basic Dynamic Rating lb/N	Dimensions inch / mm										Bolt Size	Unit Wt. lb/kg	
					A	B	C	D	G	H	J	L	N	P			T
1	SFTMH-16	MH-16	ECC-16	2801 12459	4 7/8 123.8	3 57/64 98.8	2 3/4 69.9	1 1/32 26.2	17/32 13.5	1 7/16 36.5	1 3/8 34.9	1 3/8 34.9	9/16 14.3	2 19/64 58.3	2 3/8 60.3	7/16	1.4 .61
1 3/16	SFTMH-19	MH-19	ECC-19	4381	5 9/16	4 19/32	3 1/4	1 11/64	17/32	1 9/16	1 1/2	1 19/32	5/8	2 27/64	2 7/8	7/16	2.0 0.92
1 1/4R	SFTMH-20R	MH-20R		19487	141.3	116.7	82.6	29.8	13.5	39.7	38.1	40.5	15.9	61.5	73.0		
1 1/4	SFTMH-20	MH-20	ECC-23	5782	6 1/8	5 1/8	3 3/4	1 11/32	9/16	1 3/4	1 11/16	1 55/64	11/16	2 43/64	3 5/16	1/2	3.2 1.45
1 7/16	SFTMH-23	MH-23		25718	155.6	130.2	95.3	34.1	14.3	44.5	42.9	47.2	17.5	67.8	84.1		
1 1/2	SFTMH-24	MH-24	ECC-24	7340 32648	6 3/4 171.5	5 21/32 143.7	4 1/8 104.8	1 1/2 38.1	9/16 14.3	2 1/64 51.2	1 15/16 49.2	2 1/16 52.4	3/4 19.1	2 15/16 74.6	3 1/2 88.9	1/2	3.9 1.79
1 11/16	SFTMH-27	MH-27	ECC-27	7901 35144	7 1/16 179.4	5 27/32 148.4	4 3/8 111.1	1 9/16 39.7	9/16 14.3	2 3/64 52.0	1 15/16 49.2	2 19/64 58.3	3/4 19.1	3 76.2	3 7/8 98.4	9/16	4.4 2.00
1 15/16	SFTMH-31	MH-31	ECC-31	7889 35090	7 7/16 188.9	6 3/16 157.2	4 9/16 115.9	1 9/16 39.7	9/16 14.3	2 5/32 54.8	2 1/32 51.6	2 15/32 62.7	3/4 19.1	2 63/64 75.8	4 101.6	5/8	4.7 2.12
2	SFTMH-32	MH-32	ECC-35	9752	8 1/2	7 1/4	5 1/4	1 3/4	13/16	2 5/16	2 3/16	2 23/32	7/8	3 5/32	4 1/4	5/8	7.7 3.51
2 3/16	SFTMH-35	MH-35		43377	215.9	184.2	133.4	44.5	20.6	58.7	55.6	69.1	22.2	80.2	108.0		

*Closed End Cap part number is shown for Open End Cap. See page L-4 in the Accessories section.

Metric dimensions for reference only.

Not all parts are available from stock. Please contact customer service for availability (800) 626-2120.

For more information on bearing capabilities outside of our standard offering, please contact Application Engineering (800) 626-2093.



- Duty:** Standard
- Rolling Elements:** Ball
- Housing:** Cast Iron Two Bolt Flange
- Self Alignment:** +/- 1.5 Degrees
- Lock:** Skwezloc Locking Collar
- Seal:** Contact Seal and Flinger
- Temperature:** -20° to 200°F
- Relube:** Plugged, Grease Fitting Included

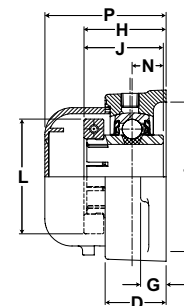
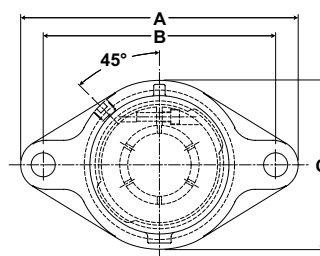

SFTMH-T Series Standard Duty 2-Bolt Flange - Skwezloc Locking Collar

Bore Diameter inch	Part No.	Bearing Insert No.	Optional End Cap*	Basic Dynamic Rating lb/N	Dimensions inch / mm											Bolt Size	Unit Wt. lb/kg
					A	B	C	D	G	H	J	L	N	P	T		
1	SFTMH-16T	MH-16T	ECC-16	2801 12459	4 7/8 123.8	3 57/64 98.8	2 3/4 69.9	1 11/32 26.2	17/32 13.5	1 1/2 38.1	1 7/16 36.5	1 15/16 49.2	9/16 14.3	2 19/64 58.3	2 3/8 60.3	7/16	1.5 .67
1 3/16 1 1/4R	SFTMH-19T SFTMH-20RT	MH-19T MH-20RT	ECC-19	4381 19487	5 9/16 141.3	4 19/32 116.7	3 1/4 82.6	1 11/64 29.8	17/32 13.5	1 5/8 41.3	1 9/16 39.7	2 3/16 55.6	5/8 15.9	2 27/64 61.5	2 7/8 73.0	7/16	2.2 .99
1 1/4	SFTMH-20T	MH-20T	ECC-23	5782 25718	6 1/8 155.6	5 1/8 130.2	3 3/4 95.3	1 11/32 34.1	9/16 14.3	1 13/16 46.0	1 3/4 44.5	2 7/16 61.9	11/16 17.5	2 43/64 67.8	3 5/16 84.1	1/2	3.5 1.58
1 7/16	SFTMH-23T	MH-23T	ECC-23	5782 25718	6 1/8 155.6	5 1/8 130.2	3 3/4 95.3	1 11/32 34.1	9/16 14.3	1 13/16 46.0	1 3/4 44.5	2 9/16 65.1	11/16 17.5	2 43/64 67.8	3 5/16 84.1	1/2	3.3 1.49
1 1/2	SFTMH-24T	MH-24T	ECC-24	7340 32648	6 3/4 171.5	5 21/32 143.7	4 1/8 104.8	1 1/2 38.1	9/16 14.3	2 5/64 52.8	2 50.8	2 11/16 68.3	3/4 19.1	2 15/16 74.6	3 1/2 88.9	1/2	4.2 1.91
1 11/16	SFTMH-27T	MH-27T	ECC-27	7901 35144	7 1/16 179.4	5 27/32 148.4	4 3/8 111.1	1 9/16 39.7	9/16 14.3	2 7/64 53.6	2 50.8	2 15/16 74.6	3/4 19.1	3 76.2	3 7/8 98.4	9/16	4.7 2.14
1 15/16	SFTMH-31T	MH-31T	ECC-31	7889 35090	7 7/16 188.9	6 3/16 157.2	4 9/16 115.9	1 9/16 39.7	9/16 14.3	2 7/32 56.4	2 3/32 53.2	3 3/8 85.7	3/4 19.1	2 63/64 75.8	4 101.6	5/8	5.3 2.39
2	SFTMH-32T	MH-32T	ECC-35	9752 43377	8 1/2 215.9	7 1/4 184.2	5 1/4 133.4	1 3/4 44.5	13/16 20.6	2 3/8 60.3	2 3/32 53.2	3 1/2 88.9	7/8 22.2	3 5/32 80.2	4 1/4 108.0	5/8	8.3 3.77
2 3/16	SFTMH-35T	MH-35T	ECC-35	9752 43377	8 1/2 215.9	7 1/4 184.2	5 1/4 133.4	1 3/4 44.5	13/16 20.6	2 3/8 60.3	2 1/4 57.2	3 5/8 92.1	7/8 22.2	3 5/32 80.2	4 1/4 108.0	5/8	8.1 3.66

*Closed End Cap part number is shown for Open End Cap. See page L-4 in the Accessories section.

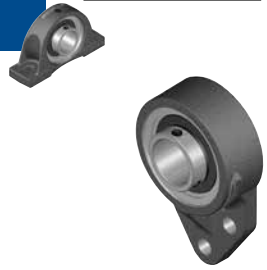

- Duty:** Standard
- Rolling Elements:** Ball
- Housing:** Cast Iron Flange Bracket
- Self Alignment:** +/- 1.5 Degrees
- Lock:** Setscrew
- Seal:** Contact Seal and Flinger
- Temperature:** -20° to 200°F
- Relube:** Plugged, Grease Fitting Included

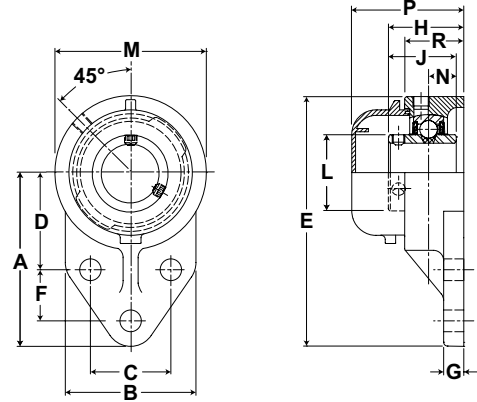

FBMH Series Standard Duty Flange Bracket - Setscrew Locking

Bore Diameter inch	Part No.	Bearing Insert No.	Optional End Cap*	Basic Dynamic Rating lb/N	Dimensions inch / mm														Bolt Size	Unit Wt. lb/kg
					A	B	C	D	E	F	G	H	J	L	M	N	P	R		
1	FBMH-16	MH-16	ECC-16	2801 12459	3 3/8 85.7	2 1/2 63.5	1 5/8 41.3	1 13/16 46.0	4 3/4 120.7	1 1/8 28.6	3/8 9.5	1 1/2 38.1	1 3/8 34.9	1 3/8 34.9	2 3/4 69.9	9/16 14.3	2 23/64 59.9	1 3/32 27.8	3/8	1.5 .68
1 3/16 1 1/4R	FBMH-19 FBMH-20R	MH-19 MH-20R	ECC-19	4381 19487	3 3/4 95.3	2 3/4 69.9	1 7/8 47.6	2 1/16 52.4	5 23/64 136.1	1 1/4 31.8	3/8 9.5	1 5/8 41.3	1 1/2 38.1	1 19/32 40.5	3 7/32 81.8	5/8 15.9	2 15/32 62.7	1 15/64 31.4	3/8	2.1 0.96
1 1/4 1 7/16	FBMH-20 FBMH-23	MH-20 MH-23	ECC-23	5782 25718	4 1/4 108.0	3 1/4 82.6	2 50.8	2 3/8 60.3	6 1/8 155.6	1 1/4 31.8	1/2 12.7	1 7/8 47.6	1 11/16 42.9	1 55/64 47.2	3 3/4 95.3	11/16 17.5	2 25/32 70.6	1 15/32 37.3	1/2	3.6 1.62
1 15/16	FBMH-31	MH-31	ECC-31	7889 35090	5 3/16 131.8	4 101.6	2 3/4 69.9	2 15/16 74.6	7 15/32 189.7	1 5/8 41.3	1/2 12.7	2 5/32 54.8	2 1/32 51.6	2 15/32 62.7	4 9/16 115.9	3/4 19.1	2 31/32 75.4	1 35/64 39.3	1/2	5.4 2.44

*Closed End Cap part number is shown for Open End Cap. See page L-4 in the Accessories section.

Metric dimensions for reference only.

Not all parts are available from stock. Please contact customer service for availability (800) 626-2120.

For more information on bearing capabilities outside of our standard offering, please contact Application Engineering (800) 626-2093.



- Duty:** Standard
- Rolling Elements:** Ball
- Housing:** Cast Iron Flange Bracket
- Self Alignment:** +/- 1.5 Degrees
- Lock:** Skwezloc Locking Collar
- Seal:** Contact Seal and Flinger
- Temperature:** -20° to 200°F
- Relube:** Plugged, Grease Fitting Included

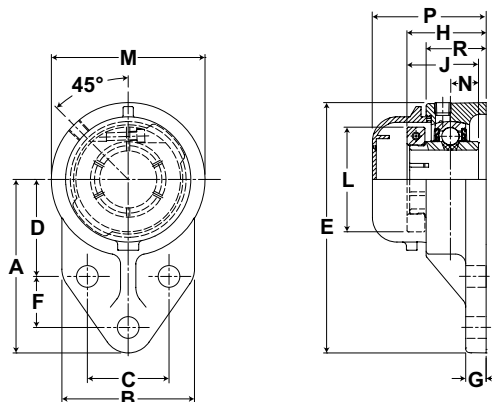

FBMH-T Series Standard Duty Flange Bracket - Skwezloc Locking Collar

Bore Diameter inch	Part No.	Bearing Insert No.	Optional End Cap*	Basic Dynamic Rating lb/N	Dimensions inch / mm														Bolt Size	Unit Wt. lb/kg
					A	B	C	D	E	F	G	H	J	L	M	N	P	R		
1	FBMH-16T	MH-16T	ECC-16	2801 12459	3 3/8 85.7	2 1/2 63.5	1 5/8 41.3	1 13/16 46.0	4 3/4 120.7	1 1/8 28.6	3/8 9.5	1 9/16 39.7	1 7/16 36.5	1 15/16 49.2	2 3/4 69.9	9/16 14.3	2 23/64 59.9	1 3/32 27.8	3/8	1.7 .75
1 3/16 1 1/4R	FBMH-19T FBMH-20RT	MH-19T MH-20RT	ECC-19	4381 19487	3 3/4 95.3	2 3/4 69.9	1 7/8 47.6	2 1/16 52.4	5 23/64 136.1	1 1/4 31.8	3/8 9.5	1 11/16 42.9	1 9/16 39.7	2 3/16 55.6	3 7/32 81.8	5/8 15.9	2 15/32 62.7	1 15/64 31.4	3/8	2.3 1.04
1 1/4	FBMH-20T	MH-20T	ECC-23	5782 25718	4 1/4 108.0	3 1/4 82.6	2 50.8	2 3/8 60.3	6 1/8 155.6	1 1/4 31.8	1/2 12.7	1 15/16 49.2	1 3/4 44.5	2 7/16 61.9	3 3/4 95.3	11/16 17.5	2 25/32 70.6	1 15/32 37.3	1/2	3.8 1.73
1 7/16	FBMH-23T	MH-23T	ECC-23	5782 25718	4 1/4 108.0	3 1/4 82.6	2 50.8	2 3/8 60.3	6 1/8 155.6	1 1/4 31.8	1/2 12.7	1 15/16 49.2	1 3/4 44.5	2 9/16 65.1	3 3/4 95.3	11/16 17.5	2 25/32 70.6	1 15/32 37.3	1/2	3.7 1.66
1 15/16	FBMH-31T	MH-31T	ECC-31	7889 35090	5 3/16 131.8	4 101.6	2 3/4 69.9	2 15/16 74.6	7 15/32 189.7	1 5/8 41.3	1/2 12.7	2 7/32 56.4	2 3/32 53.2	3 3/8 85.7	4 9/16 115.9	3/4 19.1	2 31/32 75.4	1 35/64 39.3	1/2	6.0 2.72

*Closed End Cap part number is shown for Open End Cap. See page L-4 in the Accessories section.

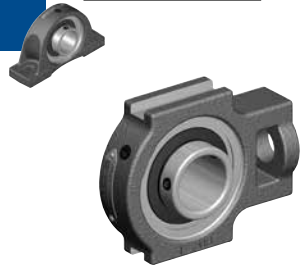

- Duty:** Standard
- Rolling Elements:** Ball
- Housing:** Cast Iron Wide Slot Take Up
- Self Alignment:** +/- 1.5 Degrees
- Lock:** Setscrew
- Seal:** Contact Seal and Flinger
- Temperature:** -20° to 200°F
- Relube:** Plugged, Grease Fitting Included

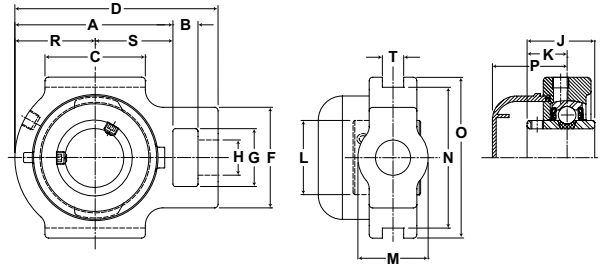

STMH Series Standard Duty Wide Slot Take Up - Setscrew Locking

Bore Diameter inch	Part No.	Bearing Insert No.	Optional End Cap*	Basic Dynamic Rating lb/N	Dimensions inch / mm																Unit Wt. lb/kg	
					A	B	C	D	F	G	H Core	J	K	L	M Hub	N	O	P	R	S		T
1	STMH-16	MH-16	ECC-16	2801 12459	2 13/16 71.4	5/8 15.9	2 50.8	3 13/16 96.8	2 50.8	1 1/4 31.8	3/4 19.1	1 3/8 34.9	13/16 20.6	1 3/8 34.9	1 1/2 38.1	3 76.2	3 1/2 88.9	1 23/32 43.7	1 3/8 34.9	1 7/16 36.5	17/32	1.9 .88
1 3/16 1 1/4R	STMH-19 STMH-20R	MH-19 MH-20R	ECC-19	4381 19487	3 7/16 87.3	5/8 15.9	2 1/4 57.2	4 7/16 112.7	2 3/16 55.6	1 7/16 36.5	7/8 22.2	1 1/2 38.1	7/16 11.1	1 19/32 40.5	1 3/4 44.5	3 1/2 88.9	4 101.6	1 25/32 45.2	1 11/16 42.9	1 7/16 36.5	17/32	3.1 1.41
1 1/4 1 7/16	STMH-20 STMH-23	MH-20 MH-23	ECC-23	5782 25718	3 15/16 100.0	5/8 15.9	2 1/2 63.5	5 1/16 128.6	2 1/2 63.5	1 7/16 36.5	7/8 22.2	1 11/16 42.9	1 25.4	1 55/64 47.2	1 3/4 44.5	3 1/2 88.9	4 101.6	1 55/64 47.2	2 50.8	1 15/16 49.2	17/32	3.9 1.77
1 1/2	STMH-24	MH-24	ECC-24	7340 32648	4 5/16 109.5	3/4 19.1	3 1/4 82.6	5 11/16 144.5	3 1/4 82.6	1 15/16 49.2	1 1/8 28.6	1 5/16 33.3	1 3/16 30.2	2 1/16 52.4	2 1/8 54.0	4 101.6	4 1/2 114.3	1 63/64 50.4	2 3/16 55.6	2 1/8 54.0	11/16	3.8 1.71
1 11/16	STMH-27	MH-27	ECC-27	7901 35144	4 5/16 109.5	3/4 19.1	3 1/4 82.6	5 11/16 144.5	3 1/4 82.6	1 15/16 49.2	1 1/8 28.6	1 5/16 33.3	1 3/16 30.2	2 19/64 58.3	2 3/16 55.6	4 101.6	4 5/8 117.5	2 1/16 52.4	2 1/4 57.2	2 1/16 52.4	11/16	5.8 2.65
1 15/16	STMH-31	MH-31	ECC-31	7889 35090	4 1/2 114.3	3/4 19.1	3 3/8 85.7	5 7/8 149.2	3 1/4 82.6	1 15/16 49.2	1 1/8 28.6	2 1/32 51.6	1 9/32 32.5	2 15/32 62.7	2 3/16 55.6	4 101.6	4 5/8 117.5	2 1/16 52.4	2 5/16 58.7	2 3/16 55.6	11/16	5.8 2.64
2 2 3/16	STMH-32 STMH-35	MH-32 MH-35	ECC-35	9752 43377	5 127.0	1 25.4	3 3/4 95.3	6 3/4 171.5	4 101.6	2 1/2 63.5	1 3/8 34.9	2 3/16 55.6	1 5/16 33.3	2 23/32 69.1	2 1/4 57.2	5 1/8 130.2	5 3/4 146.1	2 5/16 58.7	2 9/16 65.1	2 7/16 61.9	1 1/16	6.1 2.78

*Closed End Cap part number is shown for Open End Cap. See page L-4 in the Accessories section.

Metric dimensions for reference only.

Not all parts are available from stock. Please contact customer service for availability (800) 626-2120.

For more information on bearing capabilities outside of our standard offering, please contact Application Engineering (800) 626-2093.



- Duty:** Standard
- Rolling Elements:** Ball
- Housing:** Cast Iron Wide Slot Take Up
- Self Alignment:** +/- 1.5 Degrees
- Lock:** Skwezloc
- Seal:** Contact Seal and Flinger
- Temperature:** -20° to 200°F
- Relube:** Plugged, Grease Fitting Included

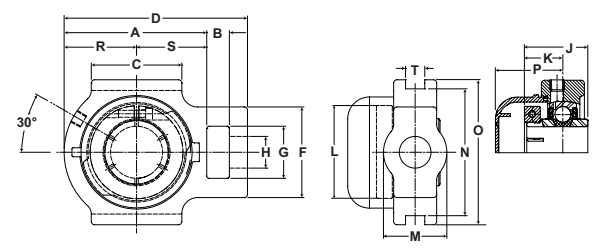

STMH-T Series Standard Duty Wide Slot Take Up - Skwezloc Locking Collar

Bore Diameter inch	Part No.	Bearing Insert No.	Optional End Cap*	Basic Dynamic Rating lb/N	Dimensions inch / mm																Unit Wt. lb/kg	
					A	B	C	D	F	G	H Core	J	K	L	M Hub	N	O	P	R	S		T
1	STMH-16T	MH-16T	ECC-16	2801 12459	2 13/16 71.4	5/8 15.9	2	3 13/16 96.8	2	1 1/4 31.8	3/4 19.1	1 7/16 36.5	7/8 22.2	1 15/16 49.2	1 1/2 38.1	3 76.2	3 1/2 88.9	1 23/32 43.7	1 3/8 34.9	1 7/16 36.5	17/32	1.9 .88
1 3/16	STMH-19T	MH-19T	ECC-19	4381 19487	3 7/16 87.3	5/8 15.9	2 1/4 57.2	4 7/16 112.7	2 3/16 55.6	1 7/16 36.5	7/8 22.2	1 9/16 39.7	15/16 23.8	2 3/16 55.6	1 3/4 44.5	3 1/2 88.9	4 101.6	1 25/32 45.2	1 11/16 42.9	1 3/4 44.5	17/32	3.1 1.41
1 1/4	STMH-20RT	MH-20RT	ECC-19																			
1 1/4	STMH-20T	MH-20T	ECC-23	5782 25718	3 15/16 100.0	5/8 15.9	2 1/2 63.5	5 1/16 128.6	2 1/2 63.5	1 7/16 36.5	7/8 22.2	1 3/4 44.5	1 1/16 27.0	2 7/16 61.9	1 3/4 44.5	3 1/2 88.9	4 101.6	1 55/64 47.2	2 50.8	1 15/16 49.2	17/32	3.9 1.77
1 7/16	STMH-23T	MH-23T	ECC-23	5782 25718	3 15/16 100.0	5/8 15.9	2 1/2 63.5	5 1/16 128.6	2 1/2 63.5	1 7/16 36.5	7/8 22.2	1 3/4 44.5	1 1/16 27.0	2 9/16 65.1	1 3/4 44.5	3 1/2 88.9	4 101.6	1 55/64 47.2	2 50.8	1 15/16 49.2	17/32	3.8 1.71
1 1/2	STMH-24T	MH-24T	ECC-24	7340 32648	4 5/16 109.5	3/4 19.1	3 1/4 82.6	5 11/16 144.5	3 1/4 82.6	1 15/16 49.2	1 1/8 28.6	2 50.8	1 1/4 31.8	2 11/16 68.3	2 1/8 54.0	4 101.6	4 1/2 114.3	1 63/64 50.4	2 3/16 55.6	2 1/8 54.0	11/16	5.8 2.65
1 11/16	STMH-27T	MH-27T	ECC-27	7901 35144	4 5/16 109.5	3/4 19.1	3 1/4 82.6	5 11/16 144.5	3 1/4 82.6	1 15/16 49.2	1 1/8 28.6	2 50.8	1 1/4 31.8	2 15/16 74.6	2 3/16 55.6	4 101.6	4 5/8 117.5	2 1/16 52.4	2 1/4 57.2	2 1/16 52.4	11/16	5.8 2.64
1 15/16	STMH-31T	MH-31T	ECC-31	7889 35090	4 1/2 114.3	3/4 19.1	3 3/8 85.7	5 7/8 149.2	3 1/4 82.6	1 15/16 49.2	1 1/8 28.6	2 3/32 53.2	1 11/32 34.1	3 3/8 85.7	2 3/16 55.6	4 101.6	4 5/8 117.5	2 1/16 52.4	2 5/16 58.7	2 3/16 55.6	11/16	6.1 2.78
2	STMH-32T	MH-32T	ECC-35	9752 43377	5 127.0	1 25.4	3 3/4 95.3	6 3/4 171.5	4 101.6	2 1/2 63.5	1 3/8 34.9	2 1/4 57.2	1 3/8 34.9	3 1/2 88.9	2 1/4 57.2	5 1/8 130.2	5 3/4 146.1	2 5/16 58.7	2 9/16 65.1	2 7/16 61.9	1 1/16	9.9 4.50
2 3/16	STMH-35T	MH-35T	ECC-35	9752 43377	5 127.0	1 25.4	3 3/4 95.3	6 3/4 171.5	4 101.6	2 1/2 63.5	1 3/8 34.9	2 1/4 57.2	1 3/8 34.9	3 5/8 92.1	2 1/4 57.2	5 1/8 130.2	5 3/4 146.1	2 5/16 58.7	2 9/16 65.1	2 7/16 61.9	1 1/16	10.4 4.69

*Closed End Cap part number is shown for Open End Cap. See page L-4 in the Accessories section.

SEALMASTER®

Material Handling Bearings



Duty: Standard
Rolling Elements: Ball
Lock: Setscrew
Seal: Contact Seal and Flinger
Temperature: -20° to 200°F

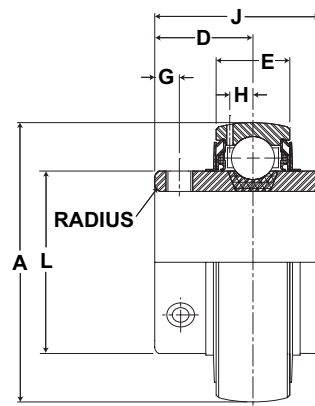

MH Series Standard Duty Insert - Setscrew Locking

Bore Diameter inch	Part No.	Dimensions inch / mm							Max. Rad. To Clear	Setscrew Thread	Unit Wt. lb/kg
		A	D	E	G	H	J	L			
1	MH-16	2.0472 52.0	13/16 20.6	.591 15.0	7/32 5.6	5/32 4.0	1 3/8 34.9	1 3/8 34.9	.040 1.0	1/4-28	.6 .27
1 3/16	MH-19	2.4409	7/8	39/55	7/32	13/64	1 1/2	1 19/32	.040	1/4-28	.9
1 1/4	MH-20R	62.0	22.2	18.0	5.6	5.2	38.1	40.5	1.0		.41
1 1/4	MH-20	2.8346	1	.748	1/4	15/64	1 11/16	1 55/64	.040	5/16-24	1.2
1 7/16	MH-23	72.0	25.4	19.0	6.4	6.0	42.9	47.2	1.0		.54
1 1/2	MH-24	3.1496 80.0	1 3/16 30.2	.866 22.0	5/16 7.9	17/64 6.7	1 15/16 49.2	2 1/16 52.4	.062 1.6	5/16-24	1.5 .68
1 11/16	MH-27	3.3465 85.0	1 3/16 30.2	.866 22.0	5/16 7.9	17/64 6.7	1 15/16 49.2	2 19/64 58.3	.062 1.6	5/16-24	1.6 .73
1 15/16	MH-31	3.5433 90.0	1 9/32 32.5	.906 23.0	3/8 9.5	9/32 7.1	2 1/32 51.6	2 15/32 62.7	.062 1.6	3/8-24	1.8 .82
2	MH-32	3.9370	1 5/16	.984	3/8	5/16	2 3/16	2 23/32	.080	3/8-24	2.3
2 3/16	MH-35	100.0	33.3	25.0	9.5	7.9	55.6	69.1	2.0		1.04
2 7/16	MH-39	4.3303 110.0	1 9/16 39.6	1.060 26.9	7/16 11.1	21/64 8.3	2 9/16 65.0	2 63/64 75.8	.080 2.0	3/8-24	3.14 1.42

Metric dimensions for reference only.

Not all parts are available from stock. Please contact customer service for availability (800) 626-2120.

For more information on bearing capabilities outside of our standard offering, please contact Application Engineering (800) 626-2093.



Duty: Standard
Rolling Elements: Ball
Lock: Skwezloc Locking Collar
Seal: Contact Seal and Flinger
Temperature: -20° to 200°F

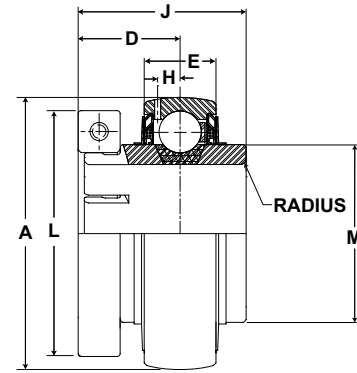

MH-T Series Standard Duty Insert - Skwezloc Locking Collar

Bore Diameter inch	Part No.	Dimensions inch / mm							Max. Rad. To Clear	Torx Cap Screw	Unit Wt. lb/kg	Lock Collar No.
		A	D	E	H	J	L	M				
1	MH-16T	2.0472 52.0	7/8 22.2	19/32 15.1	5/32 4.0	1 7/16 36.5	1 15/16 49.2	1 3/8 34.9	.040 1.0	T-25	.8 .36	2-015A Lock Collar
1 3/16 1 1/4	MH-19T MH20RT	2.4409 62.0	15/16 23.8	45/64 17.9	13/64 5.2	1 9/16 39.7	2 3/16 55.6	1 19/32 40.5	.040 1.0	T-25	1.1 .50	2-13B Lock Collar
1 1/4	MH-20T	2.8346 72.0	1 1/16 27.0	3/4 19.1	15/64 6.0	1 3/4 44.5	2 7/16 61.9	1 55/64 47.2	.040 1.0	T-27	1.5 .68	2-17A Lock Collar
1 7/16	MH-23T	2.8346 72.0	1 1/16 27.0	3/4 19.1	15/64 6.0	1 3/4 44.5	2 9/16 65.1	1 55/64 47.2	.040 1.0	T-27	1.5 .68	2-17B Lock Collar
1 1/2	MH-24T	3.1496 80.0	1 1/4 31.8	7/8 22.2	17/64 6.7	2 50.8	2 11/16 68.3	2 1/16 52.4	.062 1.6	T-27	1.8 .82	2-19A Lock Collar
1 11/16	MH-27T	3.3465 85.0	1 1/4 31.8	7/8 22.2	17/64 6.7	2 50.8	2 15/16 74.6	2 19/64 58.3	.062 1.6	T-27	1.9 .86	2-111B Lock Collar
1 15/16	MH-31T	3.5433 90.0	1 11/32 34.1	29/32 23.0	9/32 7.1	2 3/32 53.2	3 3/8 85.7	2 15/32 62.7	.062 1.6	T-30	2.4 1.09	2-115B Lock Collar
2	MH-32T	3.9370 90.0	1 3/8 34.1	63/64 23.0	5/16 7.1	2 1/4 53.2	3 1/2 85.7	2 23/32 62.7	.080 1.6	T-30	2.90 1.09	2-23A Lock Collar
2 3/16	MH-35T	3.9370 100.0	1 3/8 34.9	63/64 25.0	5/16 7.9	2 1/4 57.2	3 5/8 92.1	2 23/32 69.1	.080 2.0	T-30	2.9 1.32	2-23B Lock Collar
2 7/16	MH-39	4.3303 110.0	1 9/16 39.9	1 1/16 26.9	7/16 11.1	2 9/16 65.0	4 1/8 104.8	2 63/64 75.8	.080 2.0	T-45	3.14 1.42	2-27B Lock Collar

Sealmaster Paver Bearings

Paver bearings utilize standard Sealmaster features and improved sealing technology to meet the continuing performance needs of industrial paving equipment. Paver bearings were developed by working closely with OEM's in order to provide reliability and uptime for these severe duty applications.

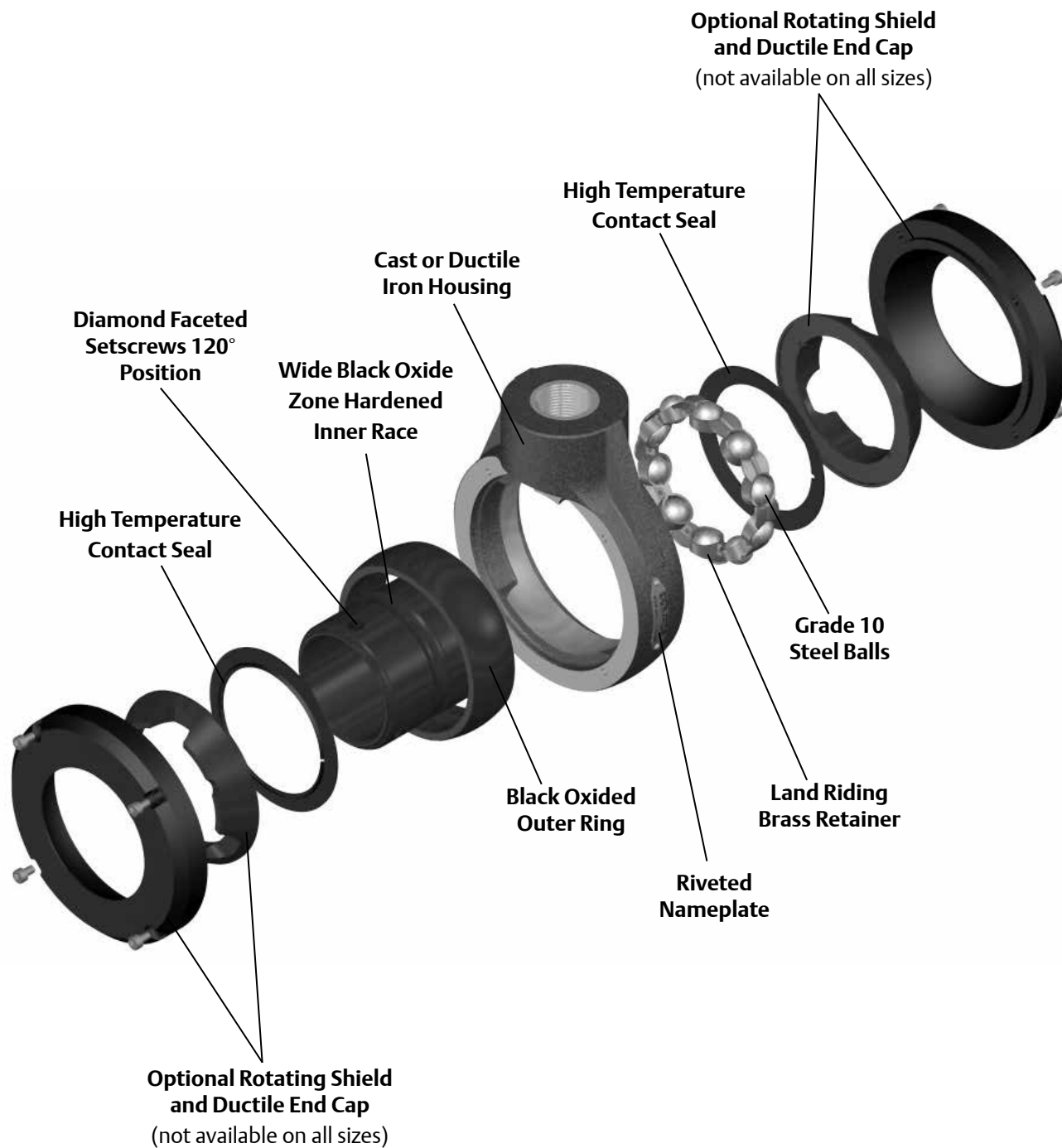



Paver Bearings Nomenclature

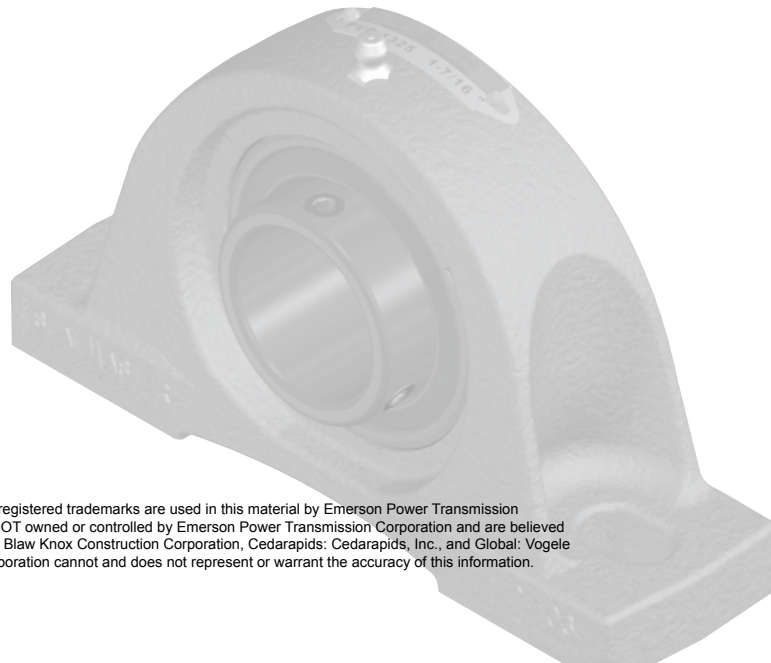
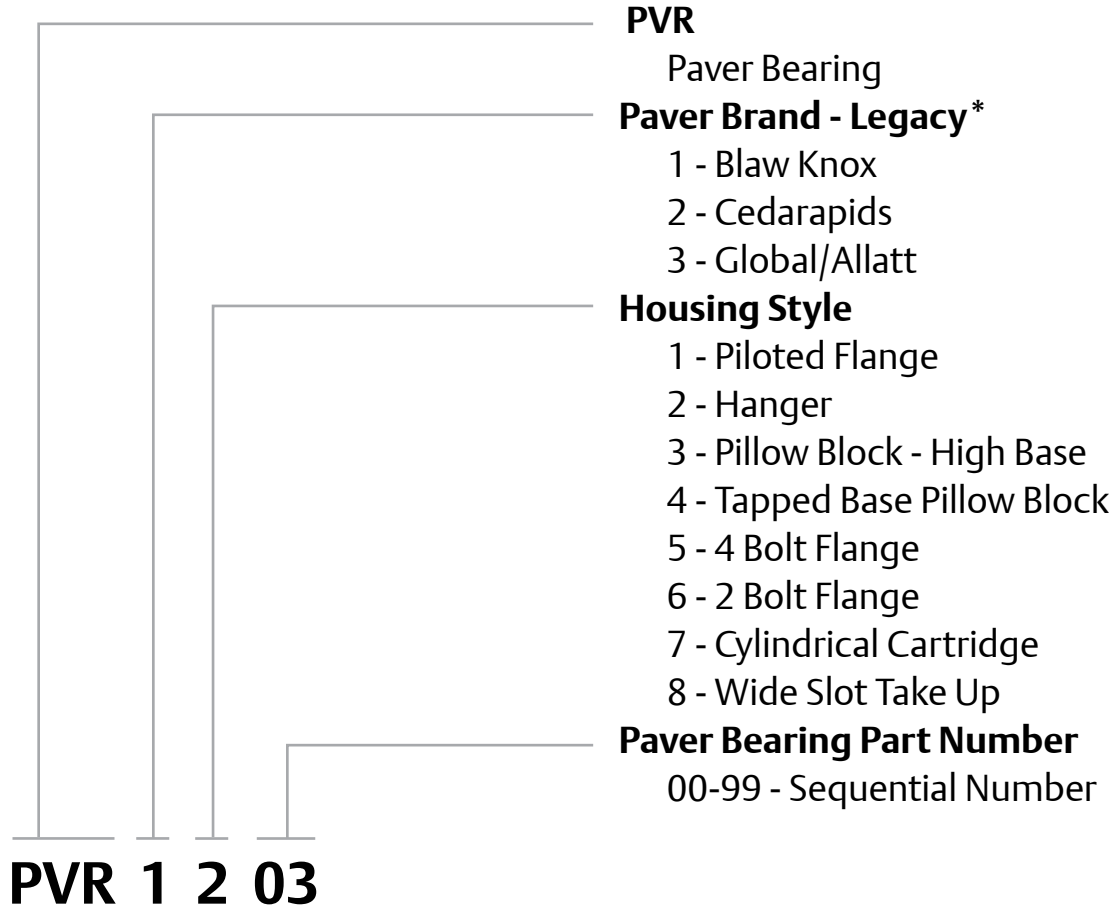

* The following trade names, trademarks and/or registered trademarks are used in this material by Emerson Power Transmission Corporation for comparison purposes only, are NOT owned or controlled by Emerson Power Transmission Corporation and are believed to be owned by the following parties: Blaw Knox: Blaw Knox Construction Corporation, Cedarapids: Cedarapids, Inc., and Global: Vogeleson America, Inc. Emerson Power Transmission Corporation cannot and does not represent or warrant the accuracy of this information.

Features and Benefits

Sealmaster Paver Bearings have been developed in conjunction with original equipment manufacturers and features vary by part number. Some common features are listed below.



High Temperature Contact Seal

The double lip high temperature contact seal is the most popular design used, some designs incorporate a high temperature single lip contact seal, or combination of different seals for the front and back side of the bearing.



Nomex* Seal with Flinger

The Nomex seal provides a high temperature, tight labyrinth seal which retains lubrication and acts as a filter to exclude contamination. The external stamping is a flinger which shields the felt from large contaminants and directs them away from the sealing surface.



Ductile Iron End Cap

A tough, wear resistant end cap that helps keep asphalt from forcing its way into the bearing. The ductile-iron, bolt-on end cap mates with the casting providing the first barrier against abrasive asphalt.



Rotating Shield

The black oxidized shield is fixed to the extended inner ring and precision machined to run with a small clearance with the end cap. The shield resists asphalt erosion and helps protect the inner sealing elements.



Self-Adjusting Washer

A conical-shaped mechanical seal is located directly behind the rotating shield supplying the bearing with a third contamination barrier. The stainless steel washer attaches to the bearing's inner ring.

*NOMEX is registered trademark of E.I. du Pont de Nemurs and Company. This trade name, trademark and/or registered trademark is property of their respective owner and is not owned or controlled by Power Transmission Solutions.

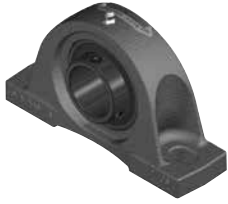

- Duty:** Varies
- Rolling Elements:** Ball
- Housing:** Pillow Block
- Lock:** Varies
- Seal:** Varies

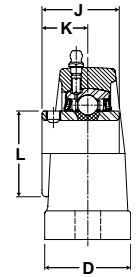
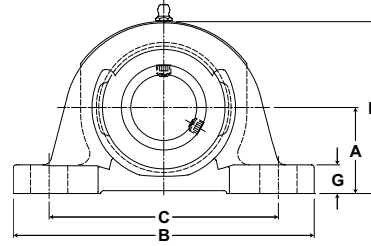

PVR x 3xx Pillow Block Assembly

Bore Diameter	Part No.	Dimensions inch / mm										Bolt Size	Unit Wt. lb/kg
		A	B	C		D	G	H	J	K	L		
inch	min.			max.									
1 1/8	PVR-1314	1 11/16 42.9	6 1/2 165.1	4 7/16 112.7	5 1/16 128.6	1 7/8 47.6	9/16 14.3	3 3/8 85.7	1 1/2 38.0	7/8 22.2	1 19/32 40.5	1/2	3.6 1.63
1 3/4	PVR-1325	2 1/8 54.0	7 1/2 190.5	5 7/16 138.1	6 1/16 154.0	2 1/8 54.0	11/16 17.5	4 1/4 108.0	1 15/16 49.2	1 3/16 30.2	2 19/64 58.3	1/2	6.5 2.95

Popular Paver bearing designs are listed, if you require information on another part number or size please consult Bearing Technical Customer Service. The basic dimensions as listed are for guidance only, the image shown may not exactly represent the unit, many units have special machining or special casting designs.

Metric dimensions for reference only.
 Not all parts are available from stock. Please contact customer service for availability (800) 626-2120.
 For more information on bearing capabilities outside of our standard offering, please contact Application Engineering (800) 626-2093.

SEALMASTER® Paver Bearings



- Duty:** Varies
- Rolling Elements:** Ball
- Housing:** Tapped Base
- Lock:** Varies
- Seal:** Varies

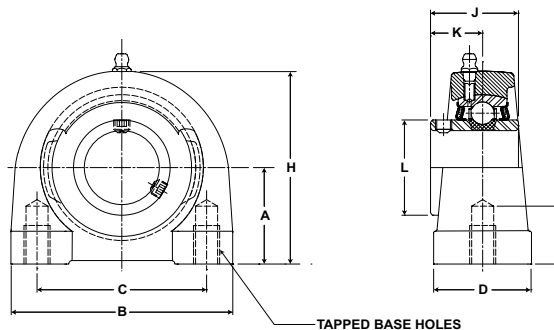

PVR x 4xx Tapped Base Pillow Block Assembly

Bore Diameter inch	Part No.	Dimensions inch / mm									Bolt UNC-2B Thread	Unit Wt. lb/kg
		A	B	C	D	H	J	K	L	N Min. Tap Depth		
1	PVR-1416	1 7/16 36.5	3 76.2	2 50.8	1 1/2 38.1	2 13/16 71.4	1 3/8 34.9	13/16 20.6	1 3/8 34.9	1/2 12.7	3/8-16	2.0 .91
1 7/16	PVR-1417	1 7/8 47.6	4 1/4 108.0	3 1/4 82.6	1 7/8 47.6	3 3/4 95.3	1 11/16 42.9	1 25.4	1 55/64 47.2	3/4 19.1	1/2-13	4.5 2.04
2	PVR-1450	2 1/4 57.2	5 127.0	4 101.6	2 50.8	4 5/8 117.5	2 1/32 51.6	1 9/32 32.5	2 15/32 62.7	7/8 22.2	5/8-11	8.0 3.63

Popular Paver bearing designs are listed, if you require information on another part number or size please consult Bearing Technical Customer Service. The basic dimensions as listed are for guidance only, the image shown may not exactly represent the unit, many units have special machining or special casting designs.

Metric dimensions for reference only.
 Not all parts are available from stock. Please contact customer service for availability (800) 626-2120.
 For more information on bearing capabilities outside of our standard offering, please contact Application Engineering (800) 626-2093.



- Duty:** Varies
- Rolling Elements:** Ball
- Housing:** Four Bolt Flange
- Lock:** Varies
- Seal:** Varies

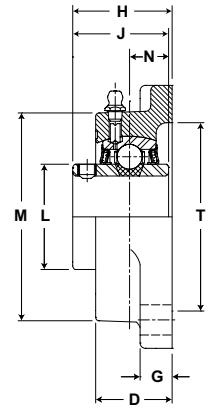
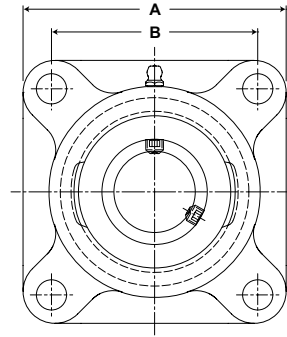

PVR x 5xx Four Bolt Flange Assembly

Bore Diameter inch	Part No.	Dimensions inch / mm										Bolt Size	Unit Wt. lb/kg
		A	B	D	G	H	J	N	L	M	T Core		
1 1/2	PVR-1504	5 1/8 130.2	4 101.6	1 1/2 38.1	9/16 14.3	2 1/64 51.2	1 15/16 49.2	3/4 19.1	2 1/16 52.4	4 5/64 103.6	3 1/2 88.9	1/2	5.5 2.49
1 9/16	PVR-1518	5 1/8 130.2	4 101.6	1 1/2 38.1	9/16 14.3	2 1/64 51.2	1 15/16 49.2	3/4 19.1	2 1/16 52.4	4 5/64 103.6	3 1/2 88.9	1/2	5.5 2.49
1 3/4	PVR-3546	5 3/8 136.5	4 1/8 104.8	1 9/16 39.7	9/16 14.3	2 3/64 52.0	1 15/16 49.2	3/4 19.1	2 19/64 58.3	4 11/32 110.3	3 7/8 98.4	9/16	5.7 2.59
1 3/4	PVR-1501	5 3/8 136.5	4 1/8 104.8	1 9/16 39.7	9/16 14.3	2 3/64 52.0	1 15/16 49.2	3/4 19.1	2 19/64 58.3	4 21/64 109.9	3 7/8 98.4	9/16	5.7 2.59
1 7/8	PVR-1509	5 5/8 142.9	4 3/8 111.1	1 9/16 39.7	9/16 14.3	2 5/32 54.8	2 1/32 51.6	3/4 19.1	2 15/32 62.7	4 33/64 114.7	4 101.6	9/16	6.4 2.90
2	PVR-1507	6 3/8 161.9	5 1/8 130.2	1 3/4 44.5	13/16 20.6	2 5/16 58.7	2 3/16 55.6	7/8 22.2	2 23/32 69.1	5 3/16 131.8	4 1/4 108.0	5/8	10.5 4.76
2 3/16	PVR-2533	5 3/4 146.1	4 7/16 112.7	1 3/4 44.5	13/16 20.6	2 3/8 60.3	2 3/16 55.6	7/8 22.2	3 5/8 92.1	5 3/16 131.8	4 1/4 108.0	9/16	11.1 5.03
2 3/16	PVR-2538	5 3/4 146.1	4 39/89 112.7	1 49/64 44.8	25/32 19.8	2 31/32 75.4	2 13/16 71.4	1 3/32 27.8	3 76.2	5 1/4 133.4	4 1/4 108.0	9/16	11.1 5.03
2 1/2	PVR-1551	7 3/8 187.3	5 7/8 149.2	2 5/16 58.7	11/16 17.5	3 76.1	2 3/4 69.9	1 1/16 27.0	3 7/16 87.3	6 1/8 155.6	5 1/8 130.2	5/8	16.4 7.44
2 11/16	PVR-1522	7 3/4 196.9	6 152.4	2 3/8 60.3	1 25.4	3 3/16 81.0	3 1/16 77.8	1 5/16 33.3	3 41/64 92.5	6 1/2 165.1	5 7/8 149.2	3/4	20.6 9.34

Popular Paver bearing designs are listed, if you require information on another part number or size please consult Bearing Technical Customer Service. The basic dimensions as listed are for guidance only, the image shown may not exactly represent the unit, many units have special machining or special casting designs.

SEALMASTER® Paver Bearings



Duty: Varies
Rolling Elements: Ball
Housing: Two Bolt Flange
Lock: Varies
Seal: Varies

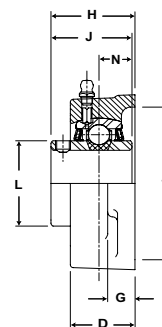
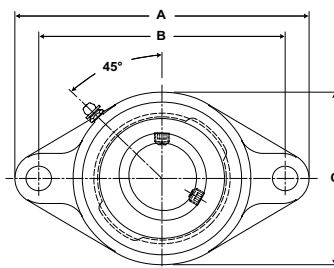

PVR x 6xx Two Bolt Flange Assembly

Bore Diameter inch	Part No.	Dimensions inch / mm										Bolt Size	Unit Wt. lb/kg
		A	B	C	D	G	H	J	N	L	T Core		
1 7/16	PVR-3647	6 1/8 155.6	5 1/8 130.2	3 3/4 95.3	1 11/32 34.1	9/16 14.3	1 3/4 44.5	1 11/16 42.9	11/16 17.5	1 27/32 46.8	3 5/16 84.1	1/2	3.2 1.45
1 9/16	PVR-1605	6 3/4 171.5	5 21/32 143.7	4 1/8 104.8	1 1/2 38.1	35/64 13.9	2 1/64 51.2	1 15/16 49.2	3/4 19.1	2 1/16 52.4	3 1/2 88.9	1/2	4.5 2.04
1 11/16	PVR-3648	7 1/16 179.4	5 27/32 148.4	4 3/8 111.1	1 9/16 39.7	9/16 14.3	2 3/64 52.0	1 15/16 49.2	3/4 19.1	2 5/16 58.7	3 7/8 98.4	9/16	5.0 2.27
1 3/4	PVR-1624	7 1/16 179.4	5 65/77 148.4	4 3/8 111.1	1 9/16 39.7	9/16 14.3	2 3/64 52.0	1 15/16 49.2	3/4 19.1	2 5/16 58.7	3 7/8 98.4	9/16	5.0 2.27
1 3/4	PVR-1626	7 7/16 188.9	6 16/85 157.2	4 9/16 115.9	1 9/16 39.7	9/16 14.3	2 5/32 54.8	2 1/32 51.6	3/4 19.1	2 15/32 62.7	4 101.6	9/16	5.6 2.54
1 7/8	PVR-1615	7 7/16 188.9	6 16/85 157.2	4 9/16 115.9	1 9/16 39.7	9/16 14.3	2 5/32 54.8	2 1/32 51.6	3/4 19.1	2 15/32 62.7	4 101.6	9/16	5.4 2.45
1 15/16	PVR-1608	7 7/16 188.9	6 16/85 157.2	4 9/16 115.9	1 9/16 39.7	9/16 14.3	2 5/32 54.8	2 1/32 51.6	3/4 19.1	2 15/32 62.7	4 101.6	9/16	5.4 2.45
2	PVR-1612	8 1/2 215.9	7 1/4 184.2	5 1/4 133.4	1 3/4 44.5	13/16 20.6	2 5/16 58.7	2 3/16 55.6	7/8 22.2	2 23/32 69.1	4 1/4 108.0	5/8	8.4 3.81

Popular Paver bearing designs are listed, if you require information on another part number or size please consult Bearing Technical Customer Service.

The basic dimensions as listed are for guidance only, the image shown may not exactly represent the unit, many units have special machining or special casting designs.

Metric dimensions for reference only.

Not all parts are available from stock. Please contact customer service for availability (800) 626-2120.

For more information on bearing capabilities outside of our standard offering, please contact Application Engineering (800) 626-2093.



- Duty:** Varies
- Rolling Elements:** Ball
- Housing:** Flange Cartridge
- Lock:** Varies
- Seal:** Varies

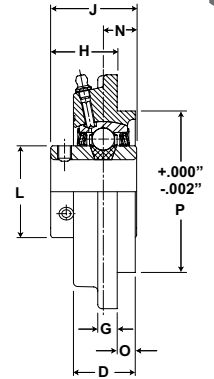
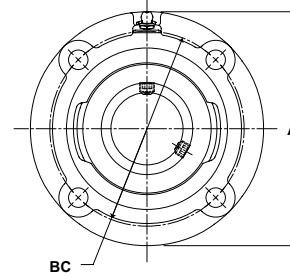

PVR x 1xx Piloted Flange Assembly

Bore Diameter inch	Part No.	Dimensions inch / mm										Bolt Size	End Cap	Unit Wt. lb/kg
		A	BC	D	G	H	J	L	N	O	P			
1 15/16	PVR-2137	6 1/8 155.6	5 1/8 130.2	1 25/64 35.3	61/64 24.2	2 50.8	2 1/32 51.6	2 15/32 62.7	23/32 18.3	7/16 11.1	4 1/4 108.0	7/16	No	7.1 3.22
2	PVR-1127	6 3/8 161.9	5 3/8 136.5	1 19/32 40.5	1 25.4	2 5/32 54.8	2 3/16 55.6	2 23/32 69.1	27/32 21.4	19/32 15.1	4 1/2 114.3	7/16	No	7.5 3.40
2 3/16	PVR-1102	7 3/4 196.9	6 1/2 165.1	1 43/64 42.5	9/16 14.3	2 3/8 60.3	2 9/16 65.1	2 63/64 75.8	1 25.4	5/16 7.9	5 1/4 133.4	1/2	Yes	10.5 4.76
2 3/16	PVR-1106	7 3/4 196.9	6 1/2 165.1	2 50.8	9/16 14.3	2 3/4 69.9	2 9/16 65.1	2 63/64 75.8	1 5/8 41.3	5/16 7.9	5 1/4 133.4	1/2	No	10.5 4.76
2 3/16	PVR-1113	7 3/4 196.9	6 1/2 165.1	2 50.8	9/16 14.3	2 3/8 60.3	2 9/16 65.1	2 63/64 75.8	1 25.4	5/16 7.9	5 1/4 133.4	1/2	No	10.5 4.76
2 3/16	PVR-1121	7 3/4 196.9	6 1/2 165.1	1 43/64 42.5	9/16 14.3	2 3/8 60.3	2 9/16 65.1	2 63/64 75.8	1 25.4	5/16 7.9	5 1/4 133.4	1/2	Yes	10.5 4.76
2 3/16	PVR-1128	7 3/4 196.9	6 1/2 165.1	2 50.8	9/16 14.3	2 3/8 60.3	2 9/16 65.1	2 63/64 75.8	1 25.4	5/16 7.9	5 1/4 133.4	1/2	No	10.5 4.76
2 3/16	PVR-3151	7 1/8 181.0	6 152.4	1 25/32 45.2	59/64 23.4	2 17/32 64.3	2 9/16 65.1	2 63/64 75.8	31/32 24.6	27/32 21.4	5 127.0	1/2	Yes	10.5 4.76

Popular Paver bearing designs are listed, if you require information on another part number or size please consult Bearing Technical Customer Service.

The basic dimensions as listed are for guidance only, the image shown may not exactly represent the unit, many units have special machining or special casting designs.

SEALMASTER® Paver Bearings



- Duty:** Varies
- Rolling Elements:** Ball
- Housing:** Hanger Bearing
- Lock:** Varies
- Seal:** Varies

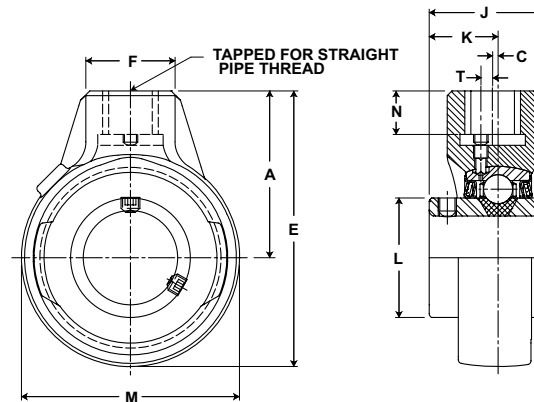

PVR x 2xx Hanger Bearing Assembly

Bore Diameter inch	Part No.	Dimensions inch / mm								Pipe Tap* N.P.S.M.	N Thread Length	Unit Wt. lb/kg
		A	C	E	F	J	K	L	M			
2	PVR-3245	3 1/4 82.6	3/16 4.8	5 7/16 138.1	1 7/8 47.6	2 1/32 51.6	1 9/32 32.5	2 15/32 62.7	4 3/8 111.1	1-11 1/2	13/16 20.6	4.5 2.04
2 7/16	PVR-3243	4 101.6	11/32 8.7	6 13/16 173.0	2 5/16 58.7	2 9/16 65.1	1 9/16 39.7	2 63/64 75.8	5 5/8 142.9	1 1/4-11 1/2	1 1/8 28.6	9.2 4.17
2 7/16	PVR-1229 PVR-1203	4 1/4 108.0	5/16 7.9	7 1/8 181.0	2 3/4 69.9	2 9/16 65.1	1 9/16 39.7	2 63/64 75.8	5 3/4 146.1	1 1/2-11 1/2	1 1/8 28.6	9.0 4.08
2 11/16	PVR-1219	4 5/8 117.5	3/8 9.5	7 7/8 200.0	2 3/4 69.9	3 1/16 77.8	1 3/4 44.5	3 41/64 92.5	6 1/2 165.1	1 1/2-11 1/2	1 1/4 31.8	14.6 6.62

Popular Paver bearing designs are listed, if you require information on another part number or size please consult Bearing Technical Customer Service.

The basic dimensions as listed are for guidance only, the image shown may not exactly represent the unit, many units have special machining or special casting designs.

*Use Straight Pipe Thread.

Metric dimensions for reference only.

Not all parts are available from stock. Please contact customer service for availability (800) 626-2120.

For more information on bearing capabilities outside of our standard offering, please contact Application Engineering (800) 626-2093.



- Duty:** Varies
- Rolling Elements:** Ball
- Housing:** Cylindrical Cartridge
- Lock:** Varies
- Seal:** Varies

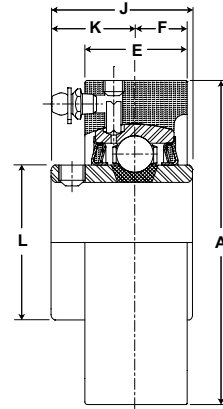

PVR x 7xx Cylindrical Cartridge Assembly

Bore Diameter inch	Part No.	Dimensions inch / mm						Unit Wt. lb/kg
		A ±.001	E	F	J	L	K	
1 3/4	PVR-1720	4.375 111.13	1 7/16 36.51	23/32 18.26	1 15/16 49.21	2 19/64 58.34	1 3/16 30.16	4.5 2.04

Popular Paver bearing designs are listed, if you require information on another part number or size please consult Bearing Technical Customer Service. The basic dimensions as listed are for guidance only, the image shown may not exactly represent the unit, many units have special machining or special casting designs.

Original Equipment Manufacture Substitution Guide

Paver Manufacturer*	Model	Manufacturer Part No.	Sealmaster Part No.	Bearing Description	Location on Paver
Global/Allatt/Champion	Various	13031950	PVR-3840	Take up	Conveyor
Global/Allatt/Champion	Various	13031943	PVR-3841	Take up	Conveyor
Global/Allatt/Champion	Various	13031919	PVR-3142	Piloted Flange	Auger Inner
Global/Allatt/Champion	Various	13031091	PVR-3243	Hanger	Auger Outer
Global/Allatt/Champion	Various	13117833	PVR-3144	Piloted Flange	Auger Inner
Global/Allatt/Champion	Various	13054846	PVR-3245	Hanger	Auger Outer
Global/Allatt/Champion	575T	13116702	PVR-3546	4 Bolt Flange	Conveyor
Global/Allatt/Champion	575T	13131974	PVR-3647	2 Bolt Flange	Auger
Global/Allatt/Champion	575T	13038591	PVR-3648	2 Bolt Flange	Auger
Global/Allatt/Champion	Various	13031927	PVR-3149	Piloted Flange	Auger Inner
Global/Allatt/Champion	Various	13031091	PVR-3250	Hanger	Auger Outer
Global/Allatt/Champion	Various	13031919, 13117833	PVR-3151	Piloted Flange	Auger Inner
Blaw Knox	PF-400A	116-112	PVR-1711	AR Style	Auger Box
Blaw Knox	Various	116-099	PVR-1710	AR Style	Auger Box
Blaw Knox	PF-150/150H	116-118	PVR-1626	2 Bolt Flange	Auger Outer
Blaw Knox	PF-172/172B	116-119, 116-026	PVR-1314	Pillow Block	Screed
Blaw Knox	Various	116-011, 116-083	PVR-1325	Pillow Block	Screed
Blaw Knox	PF-115	116-036	PVR-1624	2 Bolt Flange	Auger/Conveyor Drive
Blaw Knox	PF-180/180H/180X	116-051	PVR-1612	2 Bolt Flange	Auger/Conveyor Drive
Blaw Knox	Various	116-093	PVR-1723	SC Cartridge	Auger Box
Blaw Knox	Various	116-092	PVR-1522	4 Bolt Flange	Chain Box
Blaw Knox	PF-115, PF-120H, PF-500	116-015, 116-034, 116-103	PVR-1504	4 Bolt Flange	Conveyor/Screed
Blaw Knox	PF-161, PF-180H	116-131	PVR-1113	Piloted Flange	Conveyor Drive Screed
Blaw Knox	PF-161, PF-410, PF-3172, PF-3180, PF-3200, PF-4410, PF-5500, PF-5510	116-139	PVR-1106	Piloted Flange	Conveyor Outer Rear
Blaw Knox	PF-161, PF-172/172B, PF-180/180X, PF-510, PF-200/200B, PF-410, PF-500, PF-3200, PF-4410, PF-3172, PF-3180, PF-5500, PF-5510	116-114	PVR-1229	Hanger	Auger Outer
Blaw Knox	PF-161, PF-172/172B, PF-180/180X, PF-200/200B, PF-410, PF-500, PF-510, PF-3200, PF-4410, PF-3172, PF-3180, PF-5500, PF-5510	116-123, 116-127, 116-129, 116-141	PVR-1203	Hanger	Auger Outer
Blaw Knox	PF-200/200B, PF-172/172B, PF-161, PF-410, PF-500, PF-510, PF-3172, PF-3180, PF-4410, PF-5500, PF-5510	116-113, 116-128, 116-130, 116-143	PVR-1128	Piloted Flange	Auger Inner/Conveyor Rear Inner
Blaw Knox	PF-200/200B, PF-172/172B, PF-161, PF-410, PF-500, PF-510, PF-3172, PF-3180, PF-4410, PF-5500, PF-5510	116-142	PVR-1102	Piloted Flange	Auger Inner/Conveyor Rear Inner



Original Equipment Manufacture Substitution Guide continued

Paver Manufacturer*	Model	Manufacturer Part No.	Sealmaster Part No.	Bearing Description	Location on Paver
Blaw Knox	PF-3200, PF-3180, PF-3172	116-144	PVR-1121	Piloted Flange	Auger Inner-Power Flight Auger
Blaw Knox	PF-115, PF-120H, PF-161, PF-172/172B, PF-180/180X, PF-200/200B, PF-410, PF-510, PF-3180, PF-3200, PF-4410, PF-5500, PF-5510	116-035, 116-070, 116-071, 116-072, 116-133, 116-137, 116-138	PVR-1501	4 Bolt Flange	Conveyor
Blaw Knox	PF-150/150H	116-117	PVR-1720	SC Cartridge	Auger Inner/Conveyor Drive
Blaw Knox	Various	115-328, 116-094	PVR-1219	Hanger	Auger Outer
Blaw Knox	Various	116-068, 116-109	PVR-1518	4 Bolt Flange	Auger
Blaw Knox	PF-115	116-063	PVR-1509	4 Bolt Flange	Conveyor
Blaw Knox	PF-180/180H	116-032, 116-041	PVR-1507	4 Bolt Flange	Conveyor
Blaw Knox	PF-115, PF120H, PF-161, PF-180/180X	116-033	PVR-1127	Piloted Flange	Conveyor
Blaw Knox	PF-180H, PF-120	116-031, 116-090	PVR-1608	2 Bolt Flange	Auger/Conveyor Drive
Blaw Knox	Various	116-069	PVR-1605	2 Bolt Flange	Auger
Blaw Knox	PF-115, PF-400A	116-064, 116-122	PVR-1615	2 Bolt Flange	Auger
Blaw Knox	Various	116-145	PVR-1416	Tapped Base	Screed
Blaw Knox	PF-150/150H	116-067	PVR-1417	Tapped Base	Conveyor Front
Blaw Knox	Various	116-098	PVR-1450	Tapped Base	Conveyor
Blaw Knox	Various	116-091	PVR-1551	4 Bolt Flange	Conveyor
Blaw Knox	Road Wideners	116-095	MSF-28	4 Bolt Flange	Conveyor
Blaw Knox	Road Wideners	116-084	MSF-24	4 Bolt Flange	Conveyor
Blaw Knox	Most	115-021	ER-23	ER Style	Push Roller
Cedarapids	Various	45134-010-37	PVR-2431	Tapped Base	Auger Inner
Cedarapids	Various	45134-010-41	PVR-2130	Piloted Flange	Auger Inner
Cedarapids	Various	45134-010-39	PVR-2432	Tapped Base	Auger Remix
Cedarapids	Various	45134-010-47	PVR-2533	4 Bolt Flange	Conveyor
Cedarapids	CR-351	45134-010-40	PVR-2534	4 Bolt Flange	Conveyor
Cedarapids	CR-351, CR-451, CR-461, CR-551, CR-561	F0115-FGA	PVR-2535	4 Bolt Flange	Conveyor
Cedarapids	Various	45134-010-37	PVR-2436	Tapped Base	Auger Outer
Cedarapids	Various	45134-010-41	PVR-2137	Piloted Flange	Auger Inner
Cedarapids	Various	45134-010-47, F0203FGA	PVR-2538	4 Bolt Flange	Conveyor
Cedarapids	CR-351, CR-451, CR461, CR-551, CR-561	45134-010-40, F0115-FGA	PVR-2539	4 Bolt Flange	Conveyor

* The following trade names, trademarks and/or registered trademarks are used in this material by Emerson Power Transmission Corporation for comparison purposes only, are NOT owned or controlled by Emerson Power Transmission Corporation and are believed to be owned by the following parties: Blaw Knox: Blaw Knox Construction Corporation, Cedarapids: Cedarapids, Inc., and Global: Voegel America, Inc. Emerson Power Transmission Corporation cannot and does not represent or warrant the accuracy of this information.



Browning Mounted Ball Bearings

Browning mounted ball bearings feature multiple housing styles, materials and configurations, an extended inner race insert bearing with ball riding nylon retainer. The insert features a rivet to prevent outer ring rotation and is available with setscrew, eccentric, or BOA concentric locking collar. The contact seal, with black oxide treated flinger provides a good balance between contaminant resistance, grease loss and friction. Depending on your preference, these bearings are available in inch and metric bore with a wide variety of cast iron, stamped steel or rubber mount housings or specific industry solutions as illustrated on the pages to follow.

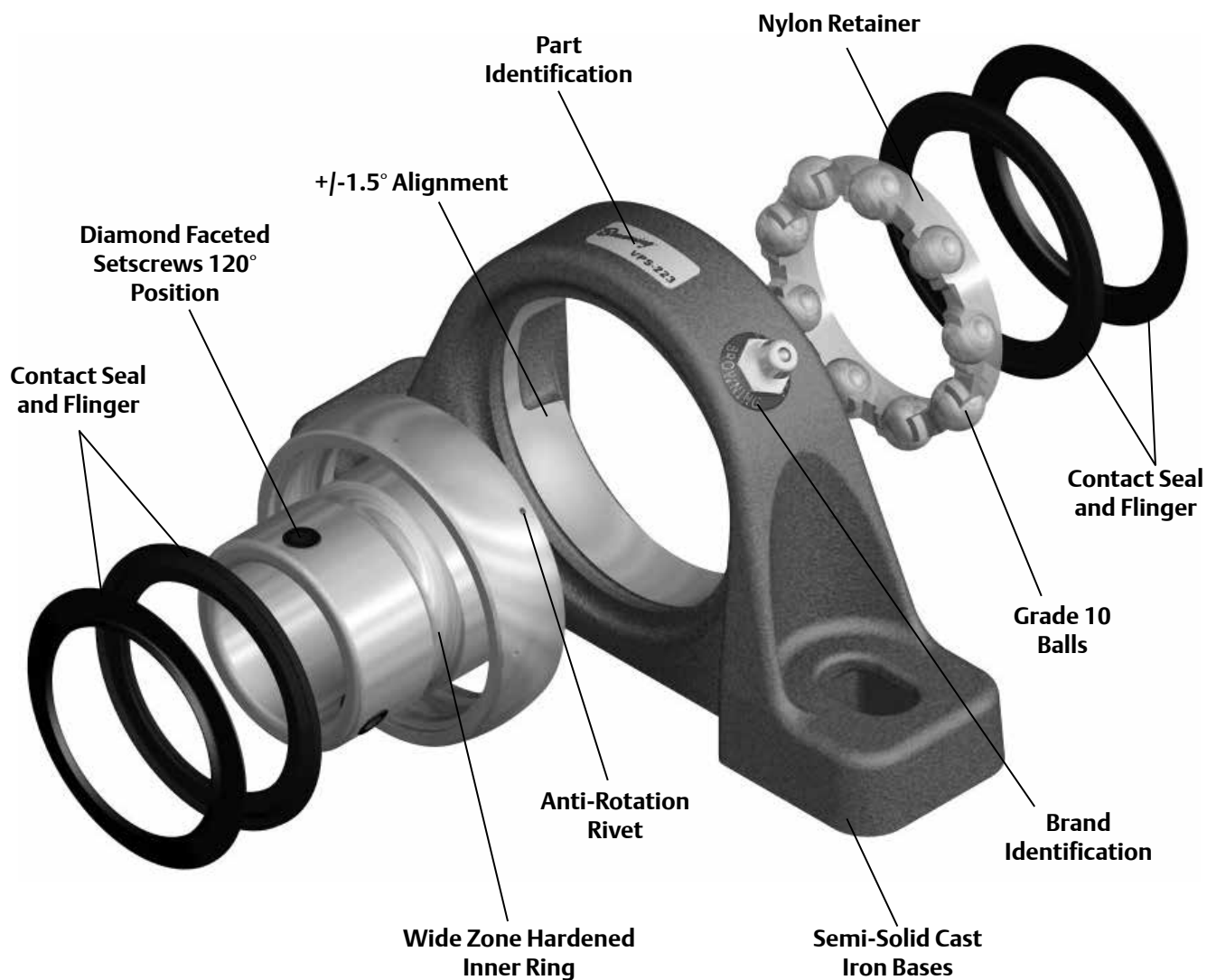



Browning Mounted Ball Nomenclature Housing Units

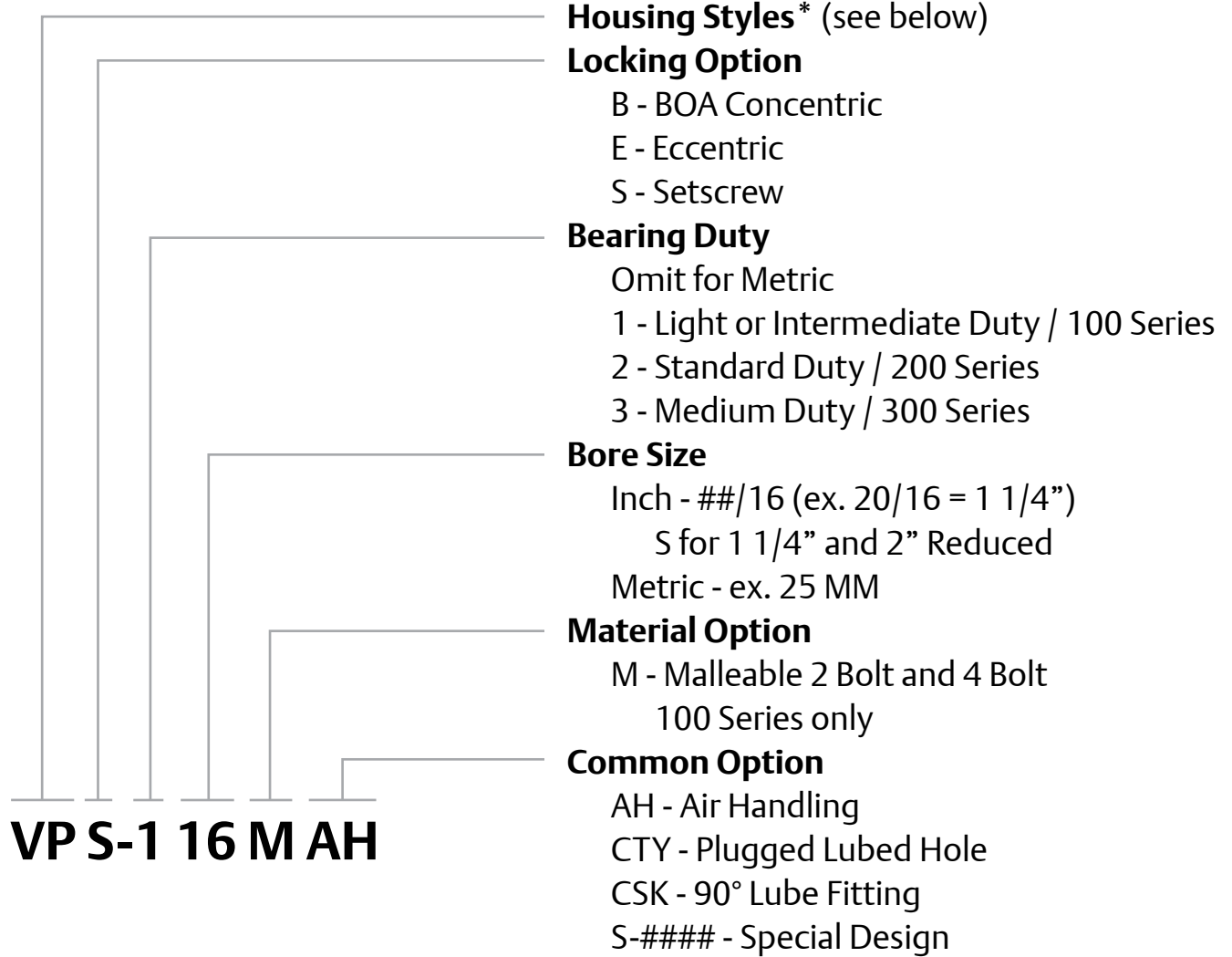

Housing	Housing Style	Material
RUBR	Grommet	Rubber
SSF2	Two Bolt Flange	Stamped Steel
SSF3	Three Bolt Flange	Stamped Steel
SSF3T	Three Bolt Flange	Stamped Steel
SSF4	Four Bolt Flange	Stamped Steel
SSP	Pillow Block	Stamped Steel
SSRP	Pillow Block	Stamped Steel / Rubber
VF2	Two Bolt Flange	Cast Iron
VF3	Three Bolt Flange	Cast Iron
VF4	Four Bolt Flange	Cast Iron
VFB	Flange Bracket	Cast Iron
VFC	Piloted Flange Cartridge	Cast Iron
VP	Pillow Block - High Base	Cast Iron
VPD	Pillow Block - Alternate Base	Cast Iron
VPL	Pillow Block - Low Base	Cast Iron
VTB	Tapped Base Pillow Block	Cast Iron
VTW	Wide Slot Take Up	Cast Iron



*Note: Configurations are not available in all sizes or housing styles. Consult the product tables, option sections and engineering sections for more detail or consult a Bearing Application Engineer.

Browning Mounted Ball Nomenclature Inserts

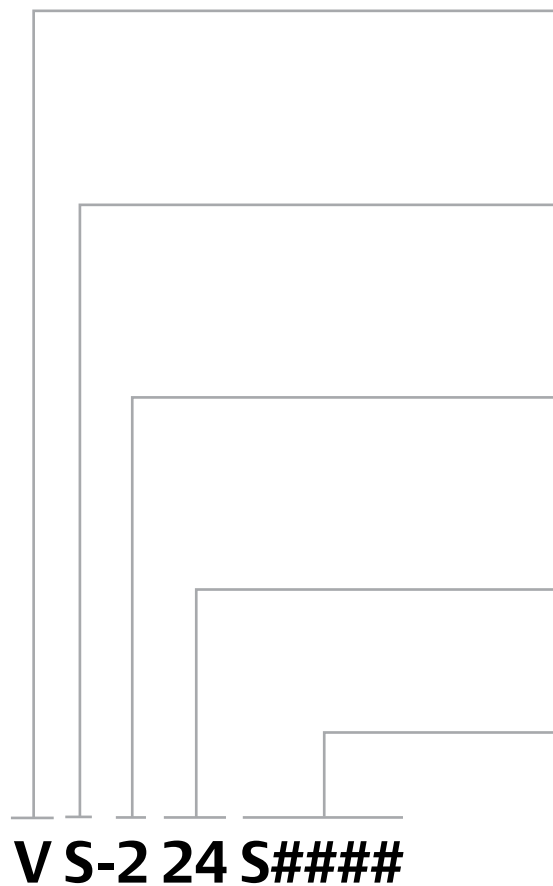

Prefix

- V - Spherical O.D. Bearing Insert
- L - Spherical O.D. Bearing Insert - No Relube
- LR - Spherical O.D. Bearing Insert - No Relube
- LRS - Spherical O.D. Bearing Insert - No Relube
- SL - Cylindrical O.D. Bearing Insert - No Relube

Locking Option

- B - BOA Concentric
- E - Eccentric
- S - Setscrew

Insert Duty

- Omit for Metric
- 1 - Light or Intermediate Duty / 100 Series
- 2 - Standard Duty / 200 Series
- 3 - Medium Duty / 300 Series

Bore Size

- Inch - ##/16 (ex. 20/16 = 1 1/4")
- S for 1 1/4" and 2" Reduced
- Metric - ex. 25 MM

Options

- SK### - Special Design



*Note: Configurations are not available in all sizes or housing styles. Consult the product tables, option sections and engineering sections for more detail or consult a Bearing Application Engineer.



Browning Mounted Ball Nomenclature Take up Frames

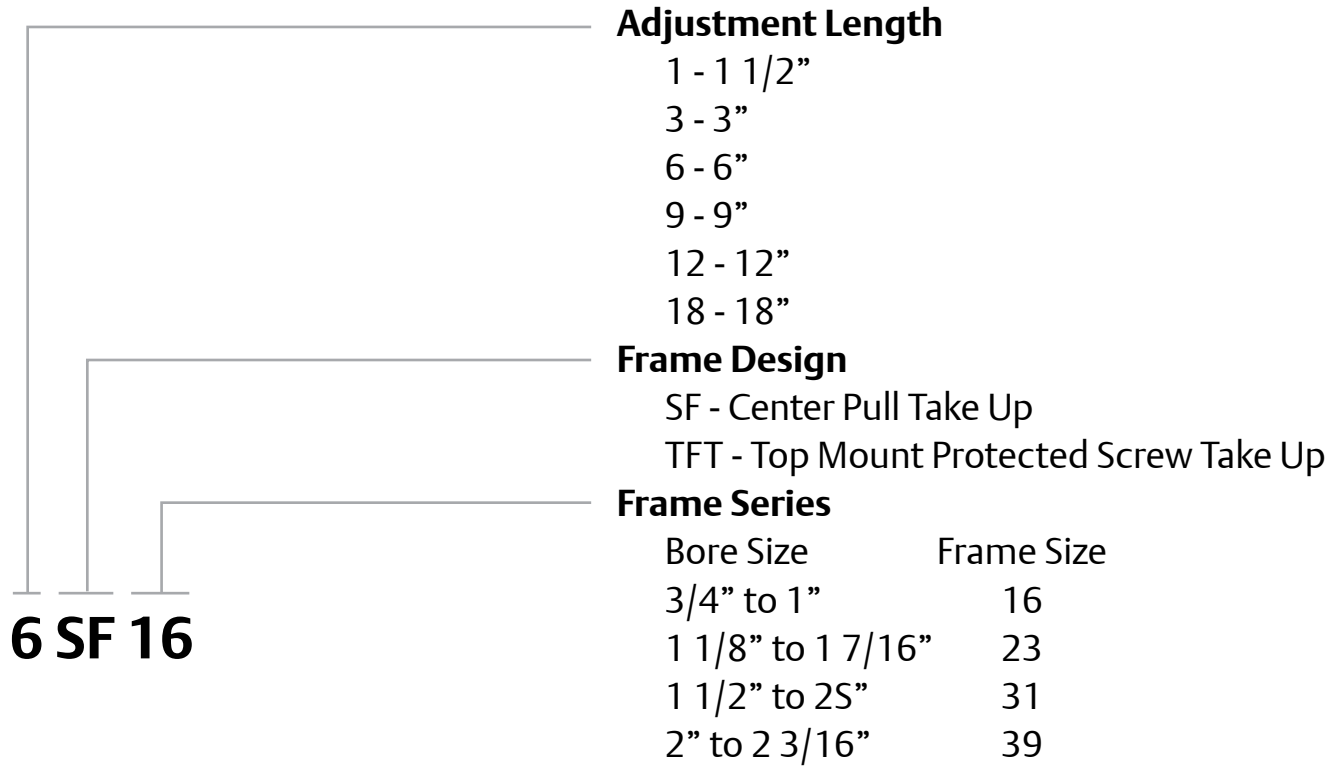



Features and Benefits

Multiple Methods Locking

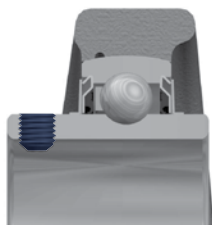

Setscrew Locking

120° spaced, balanced three point contact minimizes inner ring distortion vibration, reduces noise, and improves reliability. Precision manufactured diamond faceted setscrews contribute to improved clamping and resistance to back out.

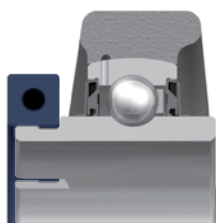

BOA Concentric

BOA is a concentric locking collar clamp design that results in near-perfect concentricity of the shaft to the bearing bore and maintains near perfect ball path roundness, while reducing fretting corrosion. This design eliminates the shaft damage of setscrew locking, and minimizes bearing induced vibration for smoother quieter operation. The collar has a TORX head cap screw that outlasts stripping 12 times longer than hex head cap screws.

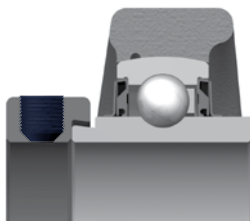

Eccentric Locking

Eccentric locking design incorporates a precision eccentric collar to mate with the inner ring extension for shaft hold.

Note: The eccentric is designed for single direction of rotation and should not be used when two direction rotation is present.



Sealing

Positive contact molded nitrile rubber contact seal with an auxiliary flinger element standard. The contact seal allows grease purge and helps keep contamination out of the bearing while the flinger provides a rotating shield that helps direct contamination away from the seal.



Anti-Rotation Rivet

An anti-rotation rivet prevents outer ring creep, or rotation, within the housing.



Features and Benefits continued



Semi-Solid Cast Iron Base

The rugged base design provides an excellent mounting foundation. This is integral to prevent sheet metal “buckling”



Zone Hardening Inner Race

Browning incorporates a unique heat treat process that hardens the inner race only where it is needed...under the ball path. The zone hardened inner race results in improved lock reliability as a result of less distortion at setscrew location and improved thread conformity resulting in improved clamping and resistance to setscrew back-out.



Identification Marking

Browning cast iron housing bearing units have a sticker with part description and brand washer under the lubrication fitting. This allows for easy verification of the part number during installation and for replacement.



Air Handling “AH” Option

The Browning Air Handling mounted ball bearing has the same features as the standard Browning mounted ball bearing expect for the following air handling features.

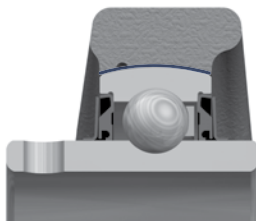

AH Housing Fit

Air Handling “AH” ball bearings are manufactured with a controlled housing fit that allows the bearing to properly self-align when mounted on lightweight frames commonly found on air handling equipment.

Noise Test

All Air Handling “AH” bearings must pass a two stage noise testing verification for quiet operation to meet the noise level standards of the air handling industry.

Popular shaft sizes and housing configurations in the normal and medium duty series are available “off-the-shelf” these air handling features (designated by the AH suffix). These products are offered in both setscrew and BOA concentric locking.

Browning®

Mounted Ball Bearings



Duty: Intermediate
Rolling Elements: Ball
Housing: Cast Iron Pillow Block
Self Alignment: +/- 1.5 Degrees
Lock: Setscrew
Seal: Contact
Temperature: -20° to 200°F

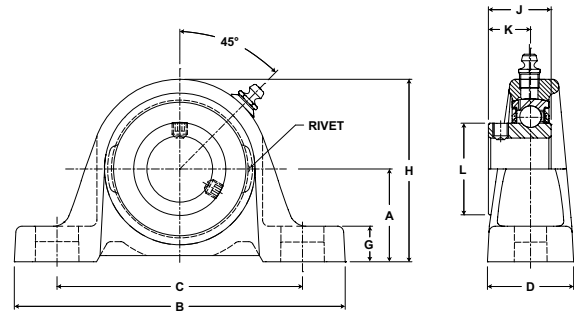

VPS 100 Series Intermediate Duty Pillow Blocks - Setscrew Locking

Bore Diameter inch	Part No.	Bearing Insert No.	Basic Dynamic Rating lb/N	Dimensions inch / mm										Bolt Size	Unit Wt. lb/kg
				A	B	C		D	G	H	J	K	L		
						min.	max.								
1/2	VPS-108	VS-108	2108	1 3/16	4 7/8	3 1/8	4 1/8	1 7/32	15/32	2 7/32	15/16	5/8	31/32	3/8	.80
5/8	VPS-110	VS-110	9377	30.2	123.8	79.4	104.8	31.0	11.9	56.4	23.8	15.9	24.6		.36
3/4	VPS-112	VS-1112	2611	1 5/16	5	3 15/32	4 9/32	1 11/32	17/32	2 17/32	1 1/16	23/32	1 3/16	3/8	1.4
			11614	33.3	127.0	88.1	108.7	34.1	13.5	64.3	27.0	18.3	30.2		.64
7/8	VPS-114	VS-114	2801	1 7/16	5 1/2	3 11/16	4 9/16	1 13/32	19/32	2 13/16	1 7/64	49/64	1 3/8	3/8	1.6
15/16	VPS-115	VS-115		36.5	139.7	93.7	115.9	35.7	15.1	71.4	28.2	19.4	34.9		.73
1	VPS-116	VS-116													
1 1/8	VPS-118	VS-118	4381	1 11/16	6 3/16	4 3/16	5 1/16	1 3/4	21/32	3 9/32	1 5/32	25/32	1 19/32	1/2	2.6
1 3/16	VPS-119	VS-119		42.9	157.2	106.4	128.6	44.5	16.7	83.3	29.4	19.8	40.5		1.18
1 1/4	VPS-120S	VS-120S													
1 1/4	VPS-120	VS-120	5782	1 7/8	6 3/4	4 5/8	5 3/8	1 3/4	23/32	3 11/16	1 9/32	55/64	1 55/64	1/2	3.5
1 3/8	VPS-122	VS-122		47.6	171.5	117.5	136.5	44.5	18.3	93.7	32.5	21.8	47.2		1.59
1 7/16	VPS-123	VS-123													
1 1/2	VPS-124	VS-124	7340	2	7 1/8	4 7/8	5 7/8	1 15/16	13/16	4	1 27/64	15/16	2 1/16	1/2	4.4
			32648	50.8	181.0	123.8	149.2	49.2	20.6	101.6	36.1	23.8	52.4		2.00
1 11/16	VPS-127	VS-127	7901	2 1/8	7 3/8	5 1/4	6 1/16	2	3/4	4 1/4	1 7/16	61/64	2 19/64	1/2	5.3
1 3/4	VPS-128	VS-128	35144	54.0	187.3	133.4	154.0	50.8	19.1	108.0	36.5	24.2	58.3		2.40
1 15/16	VPS-131	VS-131	7889	2 1/4	8	5 7/8	6 1/2	2 3/16	3/4	4 9/16	1 35/64	1 3/64	2 15/32	5/8	5.8
2	VPS-132S	VS-132S	35090	57.2	203.2	149.2	165.1	55.6	19.1	115.9	39.3	26.6	62.7		147.3
2	VPS-132	VS-132	9752	2 1/2	8 13/16	6 9/16	7 5/16	2 5/16	7/8	4 31/32	1 21/32	1 7/64	2 23/32	5/8	7.7
2 3/16	VPS-135	VS-135	43377	63.5	223.8	166.7	185.7	58.7	22.2	126.2	42.1	28.2	69.1		3.49

Metric dimensions for reference only.

Not all parts are available from stock. Please contact customer service for availability (800) 626-2120.

For more information on bearing capabilities outside of our standard offering, please contact Application Engineering (800) 626-2093.

Mounted Ball Bearings *Browning*



- Duty:** Intermediate
- Rolling Elements:** Ball
- Housing:** Cast Iron Pillow Block
- Self Alignment:** +/- 1.5 Degrees
- Lock:** Eccentric
- Seal:** Contact
- Temperature:** -20° to 200°F

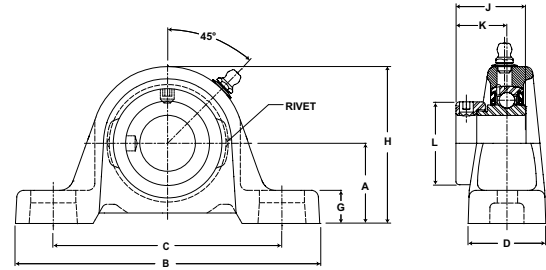

VPE 100 Series Intermediate Duty Pillow Blocks - Eccentric Locking

Bore Diameter inch	Part No.	Bearing Insert No.	Basic Dynamic Rating lb/N	Dimensions inch / mm										Bolt Size	Unit Wt. lb/kg
				A	B	C		D	G	H	J	K	L		
						min.	max.								
1/2	VPE-108	VE-108	2108	1 3/16	4 7/8	3 1/8	4 1/8	1 7/32	15/32	2 7/32	1 3/16	7/8	1 3/16	3/8	1.0
5/8	VPE-110	VE-110	9377	30.2	123.8	79.4	104.8	31.0	11.9	56.4	30.2	22.2	30.2		.45
3/4	VPE-112	VE-112	2611	1 5/16	5	3 15/32	4 9/32	1 11/32	17/32	2 17/32	1 17/64	59/64	1 5/16	3/8	1.5
			11614	33.3	127.0	88.1	108.7	34.1	13.5	64.3	32.1	23.4	33.3		.68
7/8	VPE-114	VE-114	2801	1 7/16	5 1/2	3 11/16	4 9/16	1 13/32	19/32	2 13/16	1 17/64	59/64	1 1/2	3/8	1.8
15/16	VPE-115	VE-115	12459	36.5	139.7	93.7	115.9	35.7	15.1	71.4	32.1	23.4	38.1		.82
1	VPE-116	VE-116													
1 1/8	VPE-118	VE-118	4381	1 11/16	6 3/16	4 3/16	5 1/16	1 3/4	21/32	3 9/32	1 27/64	1 3/64	1 3/4	1/2	2.9
1 3/16	VPE-119	VE-119	19487	42.9	157.2	106.4	128.6	44.5	16.7	83.3	36.1	26.6	44.5		1.32
1 1/4	VPE-120S	VE-120S													
1 1/4	VPE-120	VE-120	5782	1 7/8	6 3/4	4 5/8	5 3/8	1 3/4	23/32	3 11/16	1 37/64	1 5/32	2 3/16	1/2	3.8
1 3/8	VPE-122	VE-122	25718	47.6	171.5	117.5	136.5	44.5	18.3	93.7	40.1	29.4	55.6		1.72
1 7/16	VPE-123	VE-123													
1 1/2	VPE-124	VE-124	7340	2	7 1/8	4 7/8	5 7/8	1 15/16	13/16	4	1 49/64	1 9/32	2 3/8	1/2	5.0
			32648	50.8	181.0	123.8	149.2	49.2	20.6	101.6	44.8	32.5	60.3		2.27
1 11/16	VPE-127	VE-127	7901	2 1/8	7 3/8	5 1/4	6 1/16	2	3/4	4 1/4	1 49/64	1 9/32	2 1/2	1/2	5.7
1 3/4	VPE-128	VE-128	35144	54.0	187.3	133.4	154.0	50.8	19.1	108.0	44.8	32.5	63.5		2.59
1 15/16	VPE-131	VE-131	7889	2 1/4	8	5 7/8	6 1/2	2 3/16	3/4	4 9/16	1 25/32	1 9/32	2 3/4	5/8	6.3
2	VPE-132S	VE-132S	35090	57.2	203.2	149.2	165.1	55.6	19.1	115.9	45.2	32.5	69.9		2.86
2	VPE-132	VE-132	9752	2 1/2	8 13/16	6 9/16	7 5/16	2 5/16	7/8	4 31/32	1 63/64	1 7/16	3	5/8	8.1
2 3/16	VPE-135	VE-135	43377	63.5	223.8	166.7	185.7	58.7	22.2	126.2	50.4	36.5	76.2		3.67

Browning®

Mounted Ball Bearings



- Duty:** Standard
- Rolling Elements:** Ball
- Housing:** Cast Iron Pillow Block
- Self Alignment:** +/- 1.5 Degrees
- Lock:** Setscrew
- Seal:** Contact and Flinger
- Temperature:** -20° to 200°F

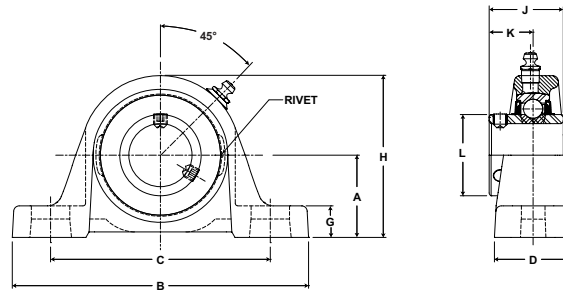

VPS 200 Series Standard Duty Pillow Blocks - Setscrew Locking - Inch

Bore Diameter inch	Part No.	Bearing Insert No.	Basic Dynamic Rating lb/N	Dimensions inch / mm										Bolt Size	Unit Wt. lb/kg
				A	B	C		D	G	H	J	K	L		
						min.	max.								
1/2	VPS-208	VS-208	2108	1 3/16	4 7/8	3 1/8	4 1/8	1 7/32	15/32	2 7/32	1 1/32	5/8	31/32	3/8	.9
5/8	VPS-210	VS-210	9377	30.2	123.8	79.4	104.8	31.0	11.9	56.4	26.2	15.9	24.6	3/8	.41
3/4	VPS-212	VS-212	2611 11614	1 5/16 33.3	5 127.0	3 3/8 85.7	4 3/16 106.4	1 11/32 34.1	17/32 13.5	2 17/32 64.3	1 7/32 31.0	23/32 18.3	1 3/16 30.2	3/8	1.4 .64
7/8	VPS-214	VS-214	2801	1 7/16	5 1/2	3 11/16	4 9/16	1 13/32	19/32	2 13/16	1 3/8	13/16	1 3/8	3/8	1.5
15/16	VPS-215	VS-215	12459	36.5	139.7	93.7	115.9	35.7	15.1	71.4	34.9	20.6	34.9	3/8	.68
1	VPS-216	VS-216													
1 1/8	VPS-218	VS-218	4381	1 11/16	6 3/16	4 3/16	5 1/16	1 3/4	21/32	3 9/32	1 1/2	7/8	1 19/32	1/2	2.5
1 3/16	VPS-219	VS-219	19487	42.9	157.2	105.6	128.6	44.5	16.7	83.3	38.1	22.2	40.5	1/2	1.13
1 1/4	VPS-220S	VS-220S													
1 1/4	VPS-220	VS-220	5782	1 7/8	6 3/4	4 5/8	5 3/8	1 3/4	23/32	3 11/16	1 11/16	1	1 55/64	1/2	3.5
1 3/8	VPS-222	VS-222	25718	47.6	171.5	117.5	136.5	44.5	18.3	93.7	42.9	25.4	47.2	1/2	1.59
1 7/16	VPS-223	VS-223													
1 1/2	VPS-224	VS-224	7340 32648	2 50.8	7 1/8 181.0	4 7/8 123.8	5 7/8 149.2	1 15/16 49.2	13/16 20.6	4 101.6	1 15/16 49.2	1 3/16 30.2	2 1/16 52.4	1/2	4.7 2.13
1 5/8	VPS-226	VS-226	7901	2 1/8	7 3/8	5 1/4	6 1/16	2	3/4	4 1/4	1 15/16	1 3/16	2 19/64	1/2	5.5
1 11/16	VPS-227	VS-227	35144	54.0	187.3	133.4	154.0	50.8	19.1	108.0	49.2	30.2	58.3	1/2	2.49
1 3/4	VPS-228	VS-228													
1 15/16	VPS-231	VS-231	7889	2 1/4	8	5 7/8	6 1/2	2 3/16	3/4	4 9/16	2 1/32	1 9/32	2 15/32	5/8	6.0
2	VPS-232S	VS-232S	35090	57.2	203.2	149.2	165.1	55.6	19.1	115.9	51.6	32.5	62.7	5/8	3.5
2	VPS-232	VS-232	9752	2 1/2	8 13/16	6 9/16	7 5/16	2 5/16	7/8	4 31/32	2 3/16	1 5/16	2 23/32	5/8	7.8
2 3/16	VPS-235	VS-235	43377	63.5	223.8	166.7	185.7	58.7	22.2	126.2	55.6	33.3	69.1	5/8	3.54
2 1/4	VPS-236	VS-236	11789	2 3/4	9 1/2	6 7/8	7 15/16	2 3/8	7/8	5 9/16	2 9/16	1 9/16	2 63/64	5/8	10.1
2 7/16	VPS-239	VS-239	52437	69.9	241.3	174.6	201.6	60.3	22.2	141.3	65.1	39.7	75.8	5/8	3.5
2 15/16	VPS-247	VS-247	14839 66004	3 5/16 84.1	12 304.8	9 1/8 231.8	9 7/8 250.8	2 7/8 73.0	1 25.4	6 5/8 168.3	3 1/16 77.8	1 3/4 44.5	3 11/64 42.5	7/8	16.9 7.67

Metric dimensions for reference only.

Not all parts are available from stock. Please contact customer service for availability (800) 626-2120.

For more information on bearing capabilities outside of our standard offering, please contact Application Engineering (800) 626-2093.

Mounted Ball Bearings *Browning*



- Duty:** Standard
- Rolling Elements:** Ball
- Housing:** Cast Iron Pillow Block
- Self Alignment:** +/- 1.5 Degrees
- Lock:** Setscrew
- Seal:** Contact and Flinger
- Temperature:** -20° to 200°F

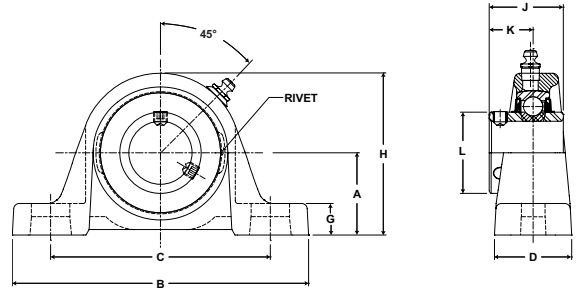

VPS-200 Series Standard Duty Pillow Blocks - Setscrew Locking - Metric

Bore Diameter mm	Part No.	Bearing Insert No.	Basic Dynamic Rating N/lb	Dimensions mm / inch										Bolt Size	Unit Wt. kg/lb
				A	B	C		D	G	H	J	K	L		
						min.	max.								
20	VPS-20 MM	VS-20 MM	11614 2611	33.3 1 5/16	127.0 5	85.7 3 3/8	106.4 4 3/16	34.1 1 11/32	13.5 17/32	64.3 2 17/32	31.0 1 7/32	18.3 23/32	30.2 1 3/16	M10	.6 1.4
25	VPS-25 MM	VS-25 MM	12459 2801	36.5 1 7/16	139.7 5 1/2	93.7 3 11/16	115.9 4 9/16	35.7 1 13/32	15.1 19/32	71.4 2 13/16	34.9 1 3/8	20.6 13/16	34.9 1 3/8	M10	.7 1.5
30	VPS-30 MM	VS-30 MM	19487 4381	42.9 1 11/16	157.2 6 3/16	105.6 4 3/16	128.6 5 1/16	44.5 1 3/4	16.7 21/32	83.3 3 9/32	38.1 1 1/2	22.2 7/8	40.5 1 19/32	M12	1.1 2.5
35	VPS-35 MM	VS-35 MM	25718 5782	47.6 1 7/8	171.5 6 3/4	117.5 4 5/8	136.5 5 3/8	44.5 1 3/4	18.3 23/32	93.7 3 11/16	42.9 1 11/16	25.4 1	47.2 1 55/64	M12	1.6 3.5
40	VPS-40 MM	VS-40 MM	32648 7340	49.2 1 89/95	181.0 7 1/8	123.8 4 7/8	149.2 5 7/8	49.2 1 15/16	20.6 13/16	100.0 3 89/95	49.2 1 15/16	30.2 1 3/16	52.4 2 1/16	M12	2.1 4.7
45	VPS-45 MM	VS-45 MM	35144 7901	54.0 2 1/8	187.3 7 3/8	133.4 5 1/4	154.0 6 1/16	50.8 2	19.1 3/4	108.0 4 1/4	49.2 1 15/16	30.2 1 3/16	58.3 2 19/64	M12	2.5 5.5
50	VPS-50 MM	VS-50 MM	35090 7889	57.2 2 1/4	203.2 8	149.2 5 7/8	165.1 6 1/2	55.6 2 3/16	19.1 3/4	115.9 4 9/16	51.6 2 1/32	32.5 1 9/32	62.7 2 15/32	M16	3.5 6
55	VPS-55 MM	VS-55 MM	43377 9752	63.5 2 1/2	223.8 8 13/16	6.7 6 9/16	185.7 7 5/16	58.7 2 5/16	22.2 7/8	126.2 4 31/32	55.6 2 3/16	33.3 1 5/16	69.1 2 23/32	M16	3.5 7.8
60	VPS-60 MM	VS-60 MM	52437 11789	69.9 2 3/4	241.3 9 1/2	174.6 6 7/8	201.6 7 15/16	60.3 2 3/8	22.2 7/8	141.3 5 9/16	65.1 2 9/16	39.7 1 9/16	75.8 2 63/64	M16	3.5 10.1



- Duty:** Standard
- Rolling Elements:** Ball
- Housing:** Cast Iron Pillow Block
- Self Alignment:** +/- 1.5 Degrees
- Lock:** BOA Concentric
- Seal:** Contact and Flinger
- Temperature:** -20° to 200°F

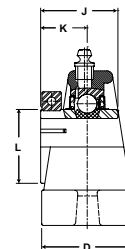
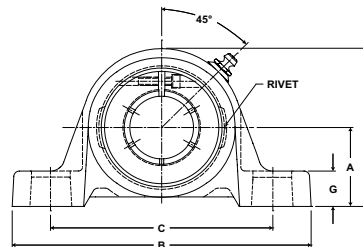

VPB 200 Series Standard Duty Pillow Blocks - BOA Concentric Locking

Bore Diameter		Part No.	Bearing Insert No.	Basic Dynamic Rating lb/N	Dimensions inch / mm										Bolt Size	Unit Wt. lb/kg	
inch	mm				A	B	C		D	G	H	J	K	L			
						min.	max.										
3/4	-	VPB-212	VB-212	2611	1 5/16	5	3 3/8	4 3/16	1 11/32	17/32	2 17/32	1 9/32	25/32	1 3/4	3/8	1.6 .73	
-	20	VPB-20MM	VB-20MM	11614	33.3	127.0	85.7	106.4	34.1	13.5	64.3	32.5	19.8	44.5			
7/8	-	VPB-214	VB-214	2801 12459	1 7/16	5 1/2	3 11/16	4 9/16	1 13/32	19/32	2 13/16	1 7/16	7/8	1 15/16	3/8	1.9 .86	
15/16	-	VPB-215	VB-215														
1	-	VPB-216	VB-216														
-	25	VPB-25MM	VB-25MM	12459	36.5	139.7	93.7	115.9	35.7	15.1	71.4	36.5	22.2	49.2			
1 1/8	-	VPB-218	VB-218	4381 19487	1 11/16	6 3/16	4 3/16	5 1/16	1 3/4	21/32	3 9/32	1 9/16	15/16	2 3/16	1/2	2.9 1.32	
1 3/16	-	VPB-219	VB-219														
1 1/4	-	VPB-220S	VB-220S														
-	30	VPB-30MM	VB-30MM	19487	42.9	157.2	106.4	128.6	44.5	16.7	83.3	39.7	23.8	55.6			
1 1/4	-	VPB-220	VB-220	5782 25718	1 7/8	6 3/4	4 5/8	5 3/8	1 3/4	23/32	3 11/16	1 3/4	1 1/16	2 7/16	1/2	3.8 1.72	
1 3/8	-	VPB-222	VB-222														
1 7/16	-	VPB-223	VB-223	5782 25718	1 7/8	6 3/4	4 5/8	5 3/8	1 3/4	23/32	3 11/16	1 3/4	1 1/16	2 9/16	1/2	3.8 1.72	
-	35	VPB-35MM	VB-35MM														
1 1/2	-	VPB-224	VB-224	7340 32648	2	7 1/8	4 7/8	5 7/8	1 15/16	13/16	4	2	1 1/4	2 11/16	1/2	4.9 2.22	
-	40	VPB-40MM	VB-40MM														
1 5/8	-	VPB-226	VB-226	7901 35144	2 1/8	7 3/8	5 1/4	6 1/16	2	3/4	4 1/4	2	1 1/4	2 13/16	1/2	5.6 2.54	
1 11/16	-	VPB-227	VB-227														
1 3/4	-	VPB-228	VB-228	7901 35144	2 1/8	7 3/8	5 1/4	6 1/16	2	3/4	4 1/4	2	1 1/4	2 15/16	1/2	5.6 2.54	
-	45	VPB-45MM	VB-45MM														
1 15/16	-	VPB-231	VB-231	7889 35090	2 1/4	8	5 7/8	6 1/2	2 3/16	3/4	4 9/16	2 3/32	1 11/32	3 3/8	5/8	6.2 2.81	
2	-	VPB-232S	VB-232S														
-	50	VPB-50MM	VB-50MM														
2	-	VPB-232	VB-232	9752 43377	2 1/2	8 13/16	6 9/16	7 5/16	2 5/16	7/8	4 31/32	2 1/4	1 3/8	3 1/2	5/8	8.0 3.63	
2 3/16	-	VPB-235	VB-235														
-	55	VPB-55MM	VB-55MM	9752 43377	2 1/2	8 13/16	6 9/16	7 5/15	2 5/16	7/8	4 31/32	2 1/4	1 3/8	3 5/8	5/8	8.0 3.63	
2 1/4	-	VPB-236	VB-236														
2 7/16	-	VPB-239	VB-239	11789 52437	2 3/4	9 1/2	6 7/8	7 15/16	2 3/8	7/8	5 9/16	2 5/8	1 5/8	4 1/16	5/8	10.1 4.58	
-	60	VPB-60MM	VB-60MM														
-	60	VPB-60MM	VB-60MM	11789 52437	2 3/4	9 1/2	6 7/8	7 15/16	2 3/8	7/8	5 9/16	2 5/8	1 5/8	4 1/8	5/8	10.1 4.58	

Metric dimensions for reference only.

Not all parts are available from stock. Please contact customer service for availability (800) 626-2120.

For more information on bearing capabilities outside of our standard offering, please contact Application Engineering (800) 626-2093.

Mounted Ball Bearings *Browning*



- Duty:** Standard
- Rolling Elements:** Ball
- Housing:** Cast Iron Pillow Block
- Self Alignment:** +/- 1.5 Degrees
- Lock:** Eccentric
- Seal:** Contact and Flinger
- Temperature:** -20° to 200°F

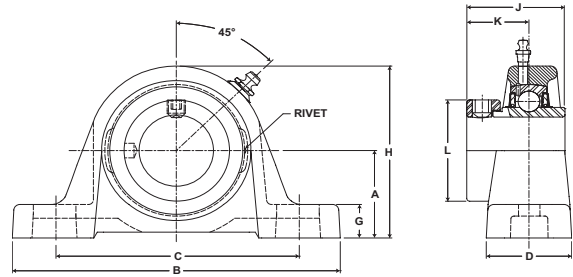

VPE 200 Series Standard Duty Pillow Blocks - Eccentric Locking

Bore Diameter inch	Part No.	Bearing Insert No.	Basic Dynamic Rating lb/N	Dimensions inch / mm										Bolt Size	Unit Wt. lb/kg
				A	B	C		D	G	H	J	K	L		
						min.	max.								
1/2	VPE-208	VE-208	2108	1 3/16	4 7/8	3 1/8	4 1/8	1 7/32	15/32	2 7/32	1 15/32	59/64	1 3/16	3/8	1.0
5/8	VPE-210	VE-210	9377	30.2	123.8	79.4	104.8	31.0	11.9	56.4	37.3	23.4	30.2		.45
3/4	VPE-212	VE-212	2611	1 5/16	5	3 3/8	4 3/16	1 11/32	17/32	2 17/32	1 23/32	1 3/64	1 5/16	3/8	1.5
			11614	33.3	127.0	85.7	106.4	34.1	13.5	64.3	43.7	26.6	33.3		.68
7/8	VPE-214	VE-214	2801	1 7/16	5 1/2	3 11/16	4 9/16	1 13/32	19/32	2 13/16	1 3/4	1 1/16	1 1/2	3/8	1.8
15/16	VPE-215	VE-215	12459	36.5	139.7	93.7	115.9	35.7	15.1	71.4	44.5	27.0	38.1		.82
1	VPE-216	VE-216													
1 1/8	VPE-218	VE-218	4381	1 11/16	6 3/16	4 3/16	5 1/16	1 3/4	21/32	3 9/32	1 29/32	1 3/16	1 3/4	1/2	2.9
1 3/16	VPE-219	VE-219	19487	42.9	157.2	106.4	128.6	44.5	16.7	83.3	48.4	30.2	44.5		1.32
1 1/4	VPE-220S	VE-220S													
1 1/4	VPE-220	VE-220	5782	1 7/8	6 3/4	4 5/8	5 3/8	1 3/4	23/32	3 11/16	2 1/64	1 9/32	2 3/16	1/2	3.8
1 3/8	VPE-222	VE-222	25718	47.6	171.5	117.5	136.5	44.5	18.3	93.7	51.2	32.5	55.6		1.72
1 7/16	VPE-223	VE-223													
1 1/2	VPE-224	VE-224	7340	2	7 1/8	4 7/8	5 7/8	1 15/16	13/16	4	2 7/32	1 3/8	2 3/8	1/2	5.0
			32648	50.8	181.0	123.8	149.2	49.2	20.6	101.6	56.4	34.9	60.3		2.27
1 5/8	VPE-226	VE-226	7901	2 1/8	7 3/8	5 1/4	6 1/16	2	3/4	4 1/4	2 7/32	1 3/8	2 1/2	1/2	5.7
1 11/16	VPE-227	VE-227	35144	54.0	187.3	133.4	154.0	50.8	19.1	108.0	56.4	34.9	63.5		2.59
1 3/4	VPE-228	VE-228													
1 15/16	VPE-231	VE-231	7889	2 1/4	8	5 7/8	6 1/2	2 3/16	3/4	4 9/16	2 15/32	1 1/2	2 3/4	5/8	6.3
			35090	57.2	203.2	149.2	165.1	55.6	19.1	115.9	62.7	38.1	69.9		2.86
2	VPE-232	VE-232	9752	2 1/2	8 13/16	6 9/16	7 5/16	2 5/16	7/8	4 31/32	2 13/16	1 23/32	3	5/8	8.1
2 3/16	VPE-235	VE-235	4377	63.5	223.8	166.7	185.7	58.7	22.2	126.2	71.4	43.7	76.2		3.67
2 1/4	VPE-236	VE-236	13971	2 3/4	9 1/2	6 7/8	7 15/16	2 3/8	7/8	5 9/16	3 1/16	1 27/32	3 3/8	5/8	10.2
2 7/16	VPE-239	VE-239	62143	69.9	241.3	174.6	201.6	60.3	22.2	141.3	77.8	46.8	85.7		4.63

Browning[®] Mounted Ball Bearings



- Duty:** Medium
- Rolling Elements:** Ball
- Housing:** Cast Iron Pillow Block
- Self Alignment:** +/- 1.5 Degrees
- Lock:** Setscrew
- Seal:** Contact and Flinger
- Temperature:** -20° to 200°F

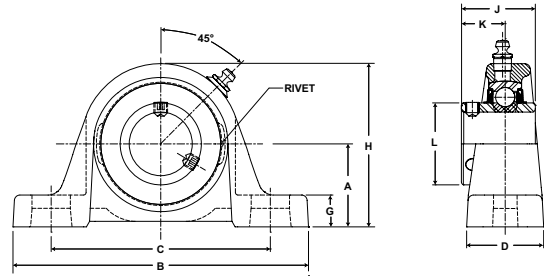

VPS 300 Series Medium Duty Pillow Blocks - Setscrew Locking

Bore Diameter inch	Part No.	Bearing Insert No.	Basic Dynamic Rating lb/N	Dimensions inch / mm										Bolt Size	Unit Wt. lb/kg
				A	B	C		D	G	H	J	K	L		
						min.	max.								
1	VPS-316	VS-316	4381 19487	1 3/4 44.5	6 3/16 157.2	4 3/16 106.4	5 1/16 128.6	1 3/4 44.5	23/32 18.3	3 11/32 84.9	1 1/2 38.1	7/8 22.2	1 19/32 40.5	1/2	3.6 1.63
1 3/16	VPS-319	VS-319	5782 25718	1 7/8 47.6	6 3/4 171.5	4 5/8 117.5	5 3/8 136.5	1 3/4 44.5	23/32 18.3	3 11/16 93.7	1 11/16 42.9	1 25.4	1 55/64 47.2	1/2	4.8 2.18
1 7/16	VPS-323	VS-323	7340 32648	2 1/8 54.0	7 1/4 184.2	5 5/16 134.9	5 3/4 146.1	2 50.8	13/16 20.6	4 3/16 106.4	1 15/16 49.2	1 3/16 30.2	2 1/16 52.4	1/2	6.2 2.81
1 1/2	VPS-324	VS-324	7901 35144	2 5/16 58.7	7 13/16 198.4	5 19/32 142.1	6 11/32 161.1	2 3/16 55.6	13/16 20.6	4 9/16 115.9	1 15/16 49.2	1 3/16 30.2	2 19/64 58.3	5/8	8.0 3.63
1 11/16	VPS-327	VS-327	7889 35090	2 5/16 58.7	7 15/16 201.6	5 3/4 146.1	6 1/2 165.1	2 1/4 57.2	13/16 20.6	4 5/8 117.5	2 1/32 51.6	1 9/32 32.5	2 15/32 62.7	5/8	8.0 3.63
1 15/16	VPS-331	VS-331	7889 35090	2 1/2 63.5	8 13/16 223.8	6 9/16 166.7	7 5/16 185.7	2 5/16 58.7	7/8 22.2	4 31/32 126.2	2 3/16 55.6	1 5/16 33.3	2 23/32 69.1	5/8	10.5 4.76
2 3/16	VPS-335	VS-335	11789 52437	2 3/4 69.9	9 1/2 241.3	6 7/8 174.6	7 15/16 201.6	2 3/8 60.3	7/8 22.2	5 9/16 141.3	2 9/16 65.1	1 9/16 39.7	2 63/64 75.8	5/8	14.3 6.49
2 1/4	VPS-336	VS-236													

Metric dimensions for reference only.

Mounted Ball Bearings *Browning*



- Duty:** Medium
- Rolling Elements:** Ball
- Housing:** Cast Iron Pillow Block
- Self Alignment:** +/- 1.5 Degrees
- Lock:** BOA Concentric
- Seal:** Contact and Flinger
- Temperature:** -20° to 200°F

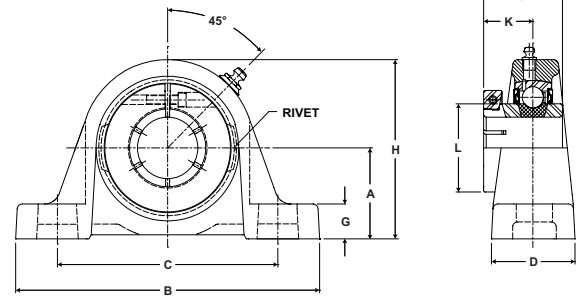

VPB 300 Series Medium Duty Pillow Blocks - BOA Concentric Locking

Bore Diameter inch	Part No.	Bearing Insert No.	Basic Dynamic Rating lb/N	Dimensions inch / mm										Bolt Size	Unit Wt. lb/kg
				A	B	C		D	G	H	J	K	L		
						min.	max.								
1	VPB-316	VB-316	4381 19487	1 3/4 44.5	6 3/16 157.2	4 3/16 106.4	5 1/16 128.6	1 3/4 44.5	23/32 18.3	3 11/32 84.9	1 9/16 39.7	15/16 23.8	2 1/16 52.4	1/2	3.1 1.41
1 3/16	VPB-319	VB-319	5782	1 7/8	6 3/4	4 5/8	5 3/8	1 3/4	23/32	3 11/16	1 3/4	1 1/16	2 7/16	1/2	3.1 1.41
1 1/4	VPB-320	VB-220	25718	47.6	171.5	117.5	136.5	44.5	18.3	93.7	44.5	27.0	61.9		
1 7/16	VPB-323	VB-323	7340 32648	2 1/8 54.0	7 1/4 184.2	5 5/16 134.9	5 3/4 146.1	2 50.8	13/16 20.6	4 3/16 106.4	2 50.8	1 1/4 31.8	2 11/16 68.3	1/2	3.9 1.77
1 1/2	VPB-324	VB-324	7901 35144	2 5/16 58.7	7 13/16 198.4	5 19/32 142.1	6 11/32 161.1	2 3/16 55.6	13/16 20.6	4 9/16 115.9	2 50.8	1 1/4 31.8	2 13/16 71.4	1/2	4.8 2.18
1 11/16	VPB-327	VB-327	7889	2 5/16	7 15/16	5 3/4	6 1/2	2 1/4	13/16	4 5/8	2 3/32	1 11/32	3 1/4	5/8	5.8 2.63
1 3/4	VPB-328	VB-328	35090	58.7	201.6	146.1	165.1	57.2	20.6	117.5	53.2	34.1	82.6		
1 15/16	VPB-331	VB-331	9752	2 1/2	8 13/16	6 9/16	7 5/16	2 5/16	7/8	4 31/32	2 1/4	1 3/8	3 1/2	5/8	8.1 3.67
2	VPB-332	VB-232	43377	63.5	223.8	166.7	185.7	58.7	22.2	126.2	57.2	34.9	88.9		
2 3/16	VPB-335	VB-335	11789 52437	2 3/4 69.9	9 1/2 241.3	6 7/8 174.6	7 15/16 201.6	2 3/8 60.3	7/8 22.2	5 9/16 141.3	2 5/8 66.7	1 5/8 41.3	4 1/16 103.2	5/8	10.4 4.72

Browning[®] Mounted Ball Bearings



- Duty:** Intermediate
- Rolling Elements:** Ball
- Housing:** Cast Iron Pillow Block – Low Base
- Self Alignment:** +/- 1.5 Degrees
- Lock:** Setscrew
- Seal:** Contact
- Temperature:** -20° to 200°F

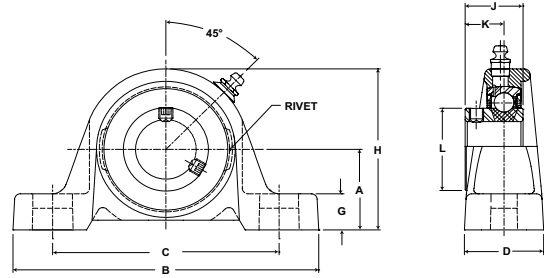

VPLS 100 Series Intermediate Duty Low Base Pillow Blocks - Setscrew Locking

Bore Diameter inch	Part No.	Bearing Insert No.	Basic Dynamic Rating lb/N	Dimensions inch / mm										Bolt Size	Unit Wt. lb/kg	
				A	B	C		D	G	H	J	K	L			
						min.	max.									
1/2	VPLS-108	VS-108	2108	1 1/16	4 7/8	3 1/8	4 1/8	1 7/32	11/32	2 3/32	15/16	5/8	31/32	3/8	.7	
5/8	VPLS-110	VS-110	9377	27.0	123.8	79.4	104.8	31.0	8.7	53.2	23.8	15.9	24.6		.32	
3/4	VPLS-112	VS-112	2611	1 1/4	5	3 15/32	4 9/32	1 11/32	15/32	2 15/32	1 1/16	23/32	1 3/16	3/8	1.3	
			11614	31.8	127.0	88.1	108.7	34.1	11.9	62.7	27.0	18.3	30.2		.59	
7/8	VPLS-114	VS-114	2801	1 5/16	5 1/2	3 11/16	4 9/16	1 13/32	15/32	2 11/16	1 7/64	49/64	1 3/8	3/8	1.4	
15/16	VPLS-115	VS-115		12459	33.3	139.7	93.7	115.9	35.7	11.9	68.3	28.2	19.4		34.9	.64
1	VPLS-116	VS-116														
1 1/8	VPLS-118	VS-118	4381	1 9/16	6 3/16	4 3/16	5 1/16	1 3/4	17/32	3 5/32	1 5/32	25/32	1 19/32	1/2	2.4	
1 3/16	VPLS-119	VS-119		19487	39.7	157.2	106.4	128.6	44.5	13.5	80.2	29.4	19.8		40.5	1.09
1 1/4	VPLS-120S	VS-120S														
1 1/4	VPLS-120	VS-120	5782	1 13/16	6 3/4	4 5/8	5 3/8	1 3/4	21/32	3 5/8	1 9/32	55/64	1 55/64	1/2	3.5	
1 3/8	VPLS-122	VS-122		25718	46.0	171.5	117.5	136.5	44.5	16.7	92.1	32.5	21.8		47.2	1.59
1 7/16	VPLS-123	VS-123														
1 1/2	VPLS-124	VS-124	7340	1 15/16	7 1/8	4 7/8	5 7/8	1 15/16	3/4	3 15/16	1 27/64	15/16	2 1/16	1/2	4.5	
			32648	49.2	181.0	123.8	149.2	49.2	19.1	100.0	36.1	23.8	52.4		2.04	
1 11/16	VPLS-127	VS-127	7901	2 1/16	7 3/8	5 7/16	5 7/8	2	11/16	4 3/16	1 7/16	61/64	2 19/64	1/2	5.5	
1 3/4	VPLS-128	VS-128	35144	52.4	187.3	138.1	149.2	50.8	17.5	106.4	36.5	24.2	58.3		2.49	
1 15/16	VPLS-131	VS-131	7889	2 3/16	8	5 7/8	6 1/2	2 3/16	11/16	4 1/2	1 35/64	1 3/64	2 15/32	5/8	5.9	
2	VPLS-132S	VS-132S	35090	55.6	203.2	149.2	165.1	55.6	17.5	114.3	39.3	26.6	62.7		2.68	
2	VPLS-132	VS-132	9752	2 7/16	8 13/16	6 9/16	7 5/16	2 5/16	13/16	4 29/32	1 21/32	1 7/64	2 23/32	5/8	7.6	
2 3/16	VPLS-135	VS-135	43377	61.9	223.8	166.7	185.7	58.7	20.6	124.6	42.1	28.2	69.1		3.45	

Metric dimensions for reference only.
 Not all parts are available from stock. Please contact customer service for availability (800) 626-2120.
 For more information on bearing capabilities outside of our standard offering, please contact Application Engineering (800) 626-2093.

Mounted Ball Bearings *Browning*



- Duty:** Intermediate
- Rolling Elements:** Ball
- Housing:** Cast Iron Pillow Block – Low Base
- Self Alignment:** +/- 1.5 Degrees
- Lock:** Eccentric
- Seal:** Contact
- Temperature:** -20° to 200°F

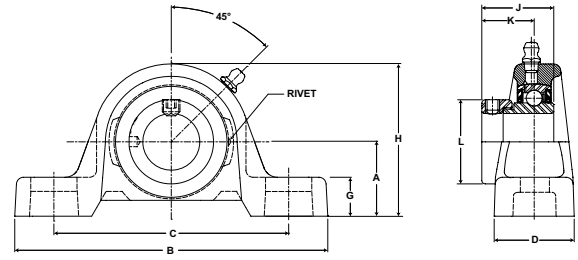

VPLE 100 Series Intermediate Duty Low Base Pillow Blocks - Eccentric Locking

Bore Diameter inch	Part No.	Bearing Insert No.	Basic Dynamic Rating lb/N	Dimensions inch / mm										Bolt Size	Unit Wt. lb/kg
				A	B	C		D	G	H	J	K	L		
						min.	max.								
1/2	VPLE-108	VE-108	2108	1 1/16	4 7/8	3 1/8	4 1/8	1 7/32	11/32	2 3/32	1 3/16	7/8	1 3/16	3/8	.8
5/8	VPLE-110	VE-110	9377	27.0	123.8	79.4	104.8	31.0	8.7	53.2	30.2	22.2	30.2		.36
3/4	VPLE-112	VE-112	2611 11614	1 1/4 31.8	5 127.0	3 15/32 88.1	4 9/32 108.7	1 11/32 34.1	15/32 11.9	2 15/32 62.7	1 17/64 32.1	59/64 23.4	1 5/16 33.3	3/8	1.4 .64
7/8	VPLE-114	VE-114	2801 12459	1 5/16	5 1/2	3 11/16	4 9/16	1 13/32	15/32	2 11/16	1 17/64	59/64	1 1/2	3/8	1.7 .77
15/16	VPLE-115	VE-115		33.3	139.7	93.7	115.9	35.7	11.9	68.3	32.1	23.4	38.1		
1	VPLE-116	VE-116													
1 1/8	VPLE-118	VE-118	4381 19487	1 9/16	6 3/16	4 3/16	5 1/16	1 3/4	17/32	3 5/32	1 27/64	1 3/64	1 3/4	1/2	2.8 1.27
1 3/16	VPLE-119	VE-119		39.7	157.2	106.4	128.6	44.5	13.5	80.2	36.1	26.6	44.5		
1 1/4	VPLE-120S	VE-120S													
1 1/4	VPLE-120	VE-120	5782 25718	1 13/16	6 3/4	4 5/8	5 3/8	1 3/4	21/32	3 5/8	1 37/64	1 5/32	2 3/16	1/2	3.7 1.68
1 3/8	VPLE-122	VE-122		46.0	171.5	117.5	136.5	44.5	16.7	92.1	40.1	29.4	55.6		
1 7/16	VPLE-123	VE-123													
1 1/2	VPLE-124	VE-124	7340 32648	1 15/16 49.2	7 1/8 181.0	4 7/8 123.8	5 7/8 149.2	1 15/16 49.2	3/4 19.1	3 15/16 100.0	1 49/64 44.8	1 9/32 32.5	2 3/8 60.3	1/2	4.8 2.18
1 11/16	VPLE-127	VE-127	7901 35144	2 1/16	7 3/8	5 7/16	5 7/8	2	11/16	4 3/16	1 49/64	1 9/32	2 1/2	1/2	5.6 2.54
1 3/4	VPLE-128	VE-128		52.4	187.3	138.1	149.2	50.8	17.5	106.4	44.8	32.5	63.5		
1 15/16	VPLE-131	VE-131	7889 35090	2 3/16	8	5 7/8	6 1/2	2 3/16	11/16	4 1/2	1 25/32	1 9/32	2 3/4	5/8	6.2 2.81
2	VPLE-132S	VE-132S		55.6	203.2	149.2	165.1	55.6	17.5	114.3	45.2	32.5	69.9		
2	VPLE-132	VE-132	9752 43377	2 7/16	8 13/16	6 9/16	7 5/16	2 5/16	13/16	4 29/32	1 63/64	1 7/16	3	5/8	7.9 3.58
2 3/16	VPLE-135	VE-135		61.9	223.8	166.7	185.7	58.7	20.6	124.6	50.4	36.5	76.2		

Browning® Mounted Ball Bearings



Duty: Standard
Rolling Elements: Ball
Housing: Cast Iron Pillow Block – Low Base
Self Alignment: +/- 1.5 Degrees
Lock: Setscrew
Seal: Contact and Flinger
Temperature: -20° to 200°F

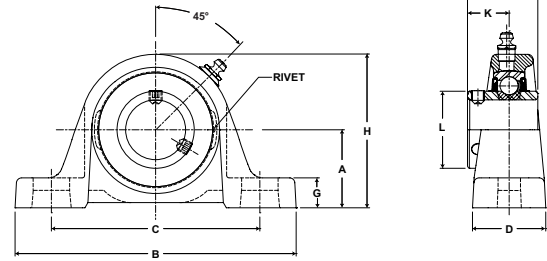

VPLS 200 Series Standard Duty Low Base Pillow Blocks - Setscrew Locking

Bore Diameter inch	Part No.	Bearing Insert No.	Basic Dynamic Rating lb/N	Dimensions inch / mm										Bolt Size	Unit Wt. lb/kg
				A	B	C		D	G	H	J	K	L		
						min.	max.								
1/2	VPLS-208	VS-208	2108	1 1/16	4 7/8	3 1/8	4 1/8	1 7/32	11/32	2 3/32	1 1/32	5/8	31/32	3/8	.7
5/8	VPLS-210	VS-210	9377	27.0	123.8	79.4	104.8	31.0	8.7	53.2	26.2	15.9	24.6		.32
3/4	VPLS-212	VS-212	2611 11614	1 1/4 31.8	5 127.0	3 3/8 85.7	4 3/16 106.4	1 11/32 34.1	15/32 11.9	2 15/32 62.7	1 7/32 31.0	23/32 18.3	1 3/16 30.2	3/8	1.3 .59
7/8	VPLS-214	VS-214	2801 12459	1 5/16	5 1/2	3 11/16	4 9/16	1 13/32	15/32	2 11/16	1 3/8	13/16	1 3/8	3/8	1.4 .64
15/16	VPLS-215	VS-215		33.3	139.7	93.7	115.9	35.7	11.9	68.3	34.9	20.6	34.9		
1	VPLS-216	VS-216													
1 1/8	VPLS-218	VS-218	4381 19487	1 9/16	6 3/16	4 3/16	5 1/16	1 3/4	17/32	3 5/32	1 1/2	7/8	1 19/32	1/2	2.4 1.09
1 3/16	VPLS-219	VS-219		39.7	157.2	106.4	128.6	44.5	13.5	80.2	38.1	22.2	40.5		
1 1/4	VPLS-220S	VS-220S													
1 1/4	VPLS-220	VS-220	5782 25718	1 13/16	6 3/4	4 5/8	5 3/8	1 3/4	21/32	3 5/8	1 11/16	1	1 55/64	1/2	3.5 1.59
1 3/8	VPLS-222	VS-222		46.0	171.5	117.5	136.5	44.5	16.7	92.1	42.9	25.4	47.3		
1 7/16	VPLS-223	VS-223													
1 1/2	VPLS-224	VS-224	7340 32648	1 15/16 49.2	7 1/8 181.0	4 7/8 123.8	5 7/8 149.2	1 15/16 49.2	3/4 19.1	3 15/16 100.0	1 15/16 49.2	1 3/16 30.2	2 1/16 52.4	1/2	4.5 2.04
1 5/8	VPLS-226	VS-226	7901 35144	2 1/16	7 3/8	5 1/4	6 1/16	2	11/16	4 3/16	1 15/16	1 3/16	2 19/64	1/2	5.5 2.49
1 11/16	VPLS-227	VS-227		52.4	187.3	133.4	154.0	50.8	17.5	106.4	49.2	30.2	58.3		
1 3/4	VPLS-228	VS-228													
1 15/16	VPLS-231	VS-231	7889 35090	2 3/16	8	5 7/8	6 1/2	2 3/16	11/16	4 1/2	2 1/32	1 9/32	2 15/32	5/8	5.9 2.68
2	VPLS-232S	VS-232S		55.6	203.2	149.2	165.1	55.6	17.5	114.3	51.6	32.5	62.7		
2	VPLS-232	VS-232	9752 43377	2 7/16	8 13/16	6 9/16	7 5/16	2 5/16	13/16	4 29/32	2 3/16	1 19/64	2 23/32	5/8	7.6 3.45
2 3/16	VPLS-235	VS-235		61.9	223.8	166.7	185.7	58.7	20.6	124.6	55.6	32.9	69.1		
2 1/4	VPLS-236	VS-236	11789 52437	2 11/16	9 1/2	6 7/8	7 15/16	2 3/8	13/16	5 1/2	2 9/16	1 9/16	2 63/64	5/8	9.7 4.40
2 7/16	VPLS-239	VS-239		68.3	241.3	174.6	201.6	60.3	20.6	139.7	65.1	39.7	75.8		

Metric dimensions for reference only.

Mounted Ball Bearings *Browning*



- Duty:** Standard
- Rolling Elements:** Ball
- Housing:** Cast Iron Pillow Block – Low Base
- Self Alignment:** +/- 1.5 Degrees
- Lock:** BOA Concentric
- Seal:** Contact and Flinger
- Temperature:** -20° to 200°F

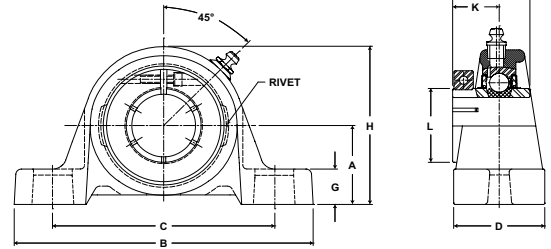

VPLB 200 Series Standard Duty Low Base Pillow Blocks - BOA Concentric Locking

Bore Diameter inch	Part No.	Bearing Insert No.	Basic Dynamic Rating lb/N	Dimensions inch / mm									Bolt Size	Unit Wt. lb/kg	
				A	B	C		D	G	H	J	K			L
						min.	max.								
3/4	VPLB-212	VB-212	2611 11614	1 1/4 31.8	5 127.0	3 3/8 85.7	4 3/16 106.4	1 11/32 34.1	15/32 11.9	2 15/32 62.7	1 9/32 32.5	25/32 19.8	1 3/4 44.5	3/8	1.4 .64
7/8	VPLB-214	VB-214	2801 12459	1 5/16 33.3	5 1/2 139.7	3 11/16 93.7	4 9/16 115.9	1 13/32 35.7	15/32 11.9	2 11/16 68.3	1 7/16 36.5	7/8 22.2	1 15/16 49.2	3/8	1.6 .73
15/16	VPLB-215	VB-215													
1	VPLB-216	VB-216													
1 1/8	VPLB-218	VB-218	4381 19487	1 9/16 39.7	6 3/16 157.2	4 3/16 106.4	5 1/16 128.6	1 3/4 44.5	17/32 13.5	3 5/32 80.2	1 9/16 39.7	15/16 23.8	2 3/16 55.6	1/2	2.6 1.18
1 3/16	VPLB-219	VB-219													
1 1/4	VPLB-220S	VB-220S													
1 1/4	VPLB-220	VB-220	5782 25718	1 13/16 46.0	6 3/4 171.5	4 5/8 117.5	5 3/8 136.5	1 3/4 44.5	21/32 16.7	3 5/8 92.1	1 3/4 44.5	1 1/16 27.0	2 7/16 61.9	1/2	3.8 1.72
1 3/8	VPLB-222	VB-222	5782 25718	1 13/16 46.0	6 3/4 171.5	4 5/8 117.5	5 3/8 136.5	1 3/4 44.5	21/32 16.7	3 5/8 92.1	1 3/4 44.5	1 1/16 27.0	2 9/16 65.1	1/2	3.8 1.72
1 7/16	VPLB-223	VB-223													
1 1/2	VPLB-224	VB-224	7340 32648	1 15/16 49.2	7 1/8 181.0	4 7/8 123.8	5 7/8 149.2	1 15/16 49.2	3/4 19.1	3 15/16 100.0	2 50.8	1 1/4 31.8	2 11/16 68.3	1/2	4.8 2.18
1 5/8	VPLB-226	VB-226	7901 35144	2 1/16 52.4	7 3/8 187.3	5 1/4 133.4	6 1/16 154.0	2 50.8	11/16 17.5	4 3/16 106.4	2 50.8	1 1/4 31.8	2 13/16 71.4	1/2	5.8 2.63
1 11/16	VPLB-227	VB-227	7901 35144	2 1/16 52.4	7 3/8 187.3	5 1/4 133.4	6 1/16 154.0	2 50.8	11/16 17.5	4 3/16 106.4	2 50.8	1 1/4 31.8	2 15/16 74.6	1/2	6.5 2.95
1 3/4	VPLB-228	VB-228													
1 15/16	VPLB-231	VB-231	7889 35090	2 3/16 55.6	8 203.2	5 7/8 149.2	6 1/2 165.1	2 3/16 55.6	11/16 17.5	4 1/2 114.3	2 3/32 53.2	1 11/32 34.1	3 3/8 85.7	5/8	6.5 2.95
2	VPLB-232S	VB-232S													
2	VPLB-232	VB-232	9752 43377	2 7/16 61.9	8 13/16 223.8	6 9/16 166.7	7 5/16 185.7	2 5/16 58.7	13/16 20.6	4 29/32 124.6	2 1/4 57.2	1 3/8 34.9	3 1/2 88.9	5/8	8.2 3.72
2 3/16	VPLB-235	VB-235	9752 43377	2 7/16 61.9	8 13/16 223.8	6 9/16 166.7	7 5/16 185.7	2 5/16 58.7	13/16 20.6	4 29/32 124.6	2 1/4 57.2	1 3/8 34.9	3 5/8 92.1	5/8	10.9 4.94
2 1/4	VPLB-236	VB-236	11789 52437	2 11/16 68.3	9 1/2 241.3	6 7/8 174.6	7 15/16 201.6	2 3/8 60.3	13/16 20.6	5 1/2 139.7	2 5/8 66.7	1 5/8 41.3	4 1/16 103.2	5/8	10.9 4.94
2 7/16	VPLB-239	VB-239	11789 52437	2 11/16 68.3	9 1/2 241.3	6 7/8 174.6	7 15/16 201.6	2 3/8 60.3	13/16 20.6	5 1/2 139.7	2 5/8 66.7	1 5/8 41.3	4 1/8 104.8	5/8	10.9 4.94

Browning® Mounted Ball Bearings



Duty: Standard
Rolling Elements: Ball
Housing: Cast Iron Pillow Block – Low Base
Self Alignment: +/- 1.5 Degrees
Lock: Eccentric
Seal: Contact and Flinger
Temperature: -20° to 200°F

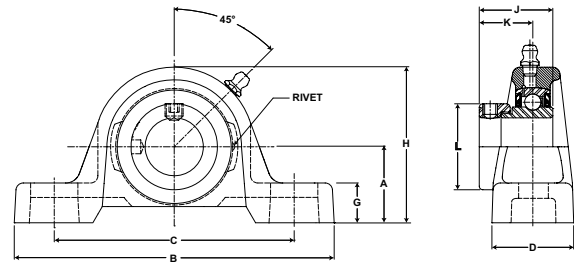

VPLE 200 Series Standard Duty Low Base Pillow Blocks - Eccentric Locking

Bore Diameter inch	Part No.	Bearing Insert No.	Basic Dynamic Rating lb/N	Dimensions inch / mm										Bolt Size	Unit Wt. lb/kg
				A	B	C		D	G	H	J	K	L		
						min.	max.								
1/2	VPLE-208	VE-208	2108	1 1/16	4 7/8	3 1/8	4 1/8	1 7/32	11/32	2 3/32	1 15/32	59/64	1 3/16	3/8	.8
5/8	VPLE-210	VE-210	9377	27.0	123.8	79.4	104.8	31.0	8.7	53.2	37.3	23.4	30.2		.36
3/4	VPLE-212	VE-212	2611 11614	1 1/4	5	3 3/8	4 3/16	1 11/32	15/32	2 15/32	1 23/32	1 3/64	1 5/16	3/8	1.4 .64
7/8	VPLE-214	VE-214	2801	1 5/16	5 1/2	3 11/16	4 9/16	1 13/32	15/32	2 11/16	1 3/4	1 1/16	1 1/2		1.7
15/16	VPLE-215	VE-215	12459	33.3	139.7	93.7	115.9	35.7	11.9	68.3	44.5	27.0	38.1	3/8	.77
1	VPLE-216	VE-216													
1 1/8	VPLE-218	VE-218	4381	1 9/16	6 3/16	4 3/16	5 1/16	1 3/4	17/32	3 5/32	1 29/32	1 3/16	1 3/4	1/2	2.8
1 3/16	VPLE-219	VE-219	19487	39.7	157.2	106.4	128.6	44.5	13.5	80.2	48.4	30.2	44.5		1.27
1 1/4	VPLE-220S	VE-220S													
1 1/4	VPLE-220	VE-220	5782	1 13/16	6 3/4	4 5/8	5 3/8	1 3/4	21/32	3 5/8	2 1/64	1 9/32	2 3/16	1/2	3.7
1 3/8	VPLE-222	VE-222	25718	46.0	171.5	117.5	136.5	44.5	16.7	92.1	51.2	32.5	55.6		1.68
1 7/16	VPLE-223	VE-223													
1 1/2	VPLE-224	VE-224	7340 32648	1 15/16	7 1/8	4 7/8	5 7/8	1 15/16	3/4	3 15/16	2 7/32	1 3/8	2 3/8	1/2	4.8 2.18
1 5/8	VPLE-226	VE-226	7901	2 1/16	7 3/8	5 1/4	6 1/16	2	11/16	4 3/16	2 7/32	1 3/8	2 1/2		5.6
1 11/16	VPLE-227	VE-227	35144	52.4	187.3	133.4	154.0	50.8	17.5	106.4	56.4	34.9	63.5	1/2	2.54
1 3/4	VPLE-228	VE-228													
1 15/16	VPLE-231	VE-231	7889 35090	2 3/16	8	5 7/8	6 1/2	2 3/16	11/16	4 1/2	2 15/32	1 1/2	2 3/4	5/8	6.2 2.81
2	VPLE-232	VE-232	9752	2 7/16	8 13/16	6 9/16	7 5/16	2 5/16	13/16	4 29/32	2 13/16	1 23/32	3	5/8	7.9
2 3/16	VPLE-235	VE-235	43377	61.9	223.8	166.7	185.7	188.9	58.7	20.6	124.6	71.4	43.7		.28
2 1/4	VPLE-236	VE-236	11789	2 11/16	9 1/2	6 7/8	7 15/16	2 3/8	13/16	5 1/2	3 1/16	1 27/32	3 3/8	5/8	10
2 7/16	VPLE-239	VE-239	52437	68.3	241.3	174.6	201.6	60.3	20.6	139.7	77.8	46.8	85.7		4.54

Metric dimensions for reference only.

Not all parts are available from stock. Please contact customer service for availability (800) 626-2120.

For more information on bearing capabilities outside of our standard offering, please contact Application Engineering (800) 626-2093.

Mounted Ball Bearings *Browning*



- Duty:** Standard
- Rolling Elements:** Ball
- Housing:** Cast Iron Pillow Block - Alternate Base
- Self Alignment:** +/- 1.5 Degrees
- Lock:** Setscrew
- Seal:** Contact
- Temperature:** -20° to 200°F

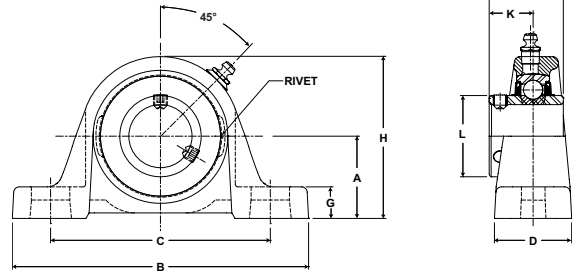

VPDS 200 Series Standard Duty Pillow Blocks - Setscrew Locking

Bore Diameter inch	Part No.	Bearing Insert No.	Basic Dynamic Rating lb/N	Dimensions inch / mm										Bolt Size	Unit Wt. lb/kg
				A	B	C		D	G	H	J	K	L		
						min.	max.								
1 3/16	VPDS-219	VS-219	4381	1 5/8	6 3/16	4 3/16	5 1/16	1 3/4	19/32	3 9/32	1 1/2	7/8	1 19/32	1/2	2.8
1 1/4	VPDS-220S	VS-220S	19487	41.3	157.2	106.4	128.6	44.5	15.1	83.3	38.1	22.2	40.5		1.27
1 1/2	VPDS-224	VS-224	7340 32648	2 1/8 54.0	7 1/4 184.2	5 7/32 132.6	5 27/32 148.4	2 50.8	13/16 20.6	4 3/16 106.4	1 15/16 49.2	1 3/16 30.2	2 1/16 52.4	1/2	5.3 2.40

Browning[®] Mounted Ball Bearings



- Duty:** Intermediate
- Rolling Elements:** Ball
- Housing:** Cast Iron Tapped Base Pillow Block
- Self Alignment:** +/- 1.5 Degrees
- Lock:** Eccentric
- Seal:** Contact
- Temperature:** -20° to 200°F

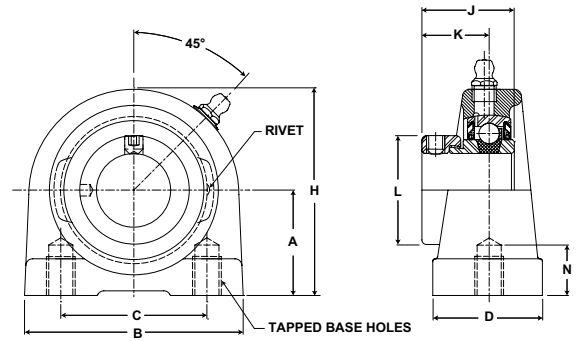

VTBE 100 Series Intermediate Duty Tapped Base Pillow Blocks - Eccentric Locking

Bore Diameter inch	Part No.	Bearing Insert No.	Basic Dynamic Rating lb/N	Dimensions inch / mm								Tapped Hole Thread Size	N Min Tap Depth	Unit Wt. lb/kg
				A	B	C	D	H	J	K	L			
3/4	VTBE-112	VE-112	2611 11614	1 5/16 33.3	2 7/8 73.0	2 50.8	1 1/2 38.1	2 9/16 65.1	1 17/64 32.1	59/64 23.4	1 5/16 33.3	3/8-16	1/2	1.5 .68
7/8	VTBE-114	VE-114	2801 12459	1 7/16 36.5	3 76.2	2 50.8	1 1/2 38.1	2 13/16 71.4	1 17/64 32.1	59/64 23.4	1 1/2 38.1	3/8-16	1/2	1.6 .73
15/16	VTBE-115	VE-115												
1	VTBE-116	VE-116												
1 1/8	VTBE-118	VE-118	4381 19487	1 11/16 42.9	4 101.6	3 76.2	1 1/2 38.1	3 3/8 85.7	1 27/64 36.1	1 3/64 26.6	1 3/4 44.5	7/16-14	5/8	2.5 1.13
1 3/16	VTBE-119	VE-119												
1 1/4	VTBE-120S	VE-120S												
1 1/4	VTBE-120	VE-120	5782 25718	1 7/8 47.6	4 1/4 108.0	3 1/4 82.6	1 7/8 47.6	3 3/4 95.3	1 37/64 40.1	1 5/32 29.4	2 3/16 55.6	1/2-13	3/4	3.4 1.54
1 3/8	VTBE-122	VE-122												
1 7/16	VTBE-123	VE-123												
1 1/2	VTBE-124	VE-124	7340 32648	1 15/16 49.2	4 5/8 117.5	3 1/2 88.9	1 7/8 47.6	3 15/16 100.0	1 49/64 44.8	1 9/32 32.5	2 3/8 60.3	1/2-13	3/4	3.8 1.72
1 11/16	VTBE-127	VE-127	7901 35144	2 1/8 54.0	5 127.0	3 3/4 95.3	2 50.8	4 1/4 108.0	1 49/64 44.8	1 9/32 32.5	2 1/2 63.5	1/2-13	3/4	4.7 2.13
1 3/4	VTBE-128	VE-128												
1 15/16	VTBE-131	VE-131	7889 35090	2 1/4 57.2	5 1/2 139.7	4 101.6	2 50.8	4 5/8 117.5	1 25/32 45.2	1 9/32 32.5	2 3/4 69.9	5/8-11	7/8	5.7 2.59
2	VTBE-132S	VE-132S												

Metric dimensions for reference only.

Not all parts are available from stock. Please contact customer service for availability (800) 626-2120.

For more information on bearing capabilities outside of our standard offering, please contact Application Engineering (800) 626-2093.

Mounted Ball Bearings *Browning*



- Duty:** Standard
- Rolling Elements:** Ball
- Housing:** Cast Iron Tapped Base Pillow Block
- Self Alignment:** +/- 1.5 Degrees
- Lock:** Setscrew
- Seal:** Contact and Flinger
- Temperature:** -20° to 200°F

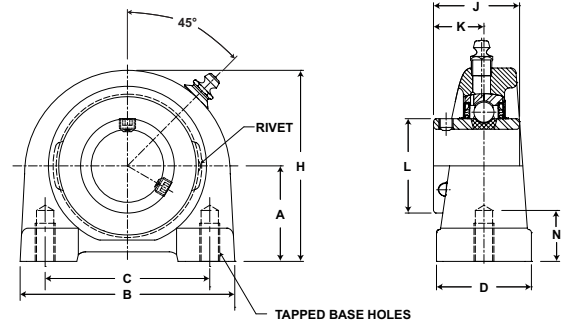

VTBS 200 Series Standard Duty Tapped Base Pillow Blocks - Setscrew Locking

Bore Diameter inch	Part No.	Bearing Insert No.	Basic Dynamic Rating lb/N	Dimensions inch / mm								Tapped Hole Thread Size	N Min Tap Depth	Unit Wt. lb/kg
				A	B	C	D	H	J	K	L			
1/2	VTBS-208	VS-208	2108	1 5/16	2 7/8	2	1 1/2	2 9/16	1 1/32	5/8	31/32	3/8-16	1/2	1.3 .59
5/8	VTBS-210	VS-210	9377	33.3	73.0	50.8	38.1	65.1	26.2	15.9	24.6			
3/4	VTBS-212	VS-212	2611 11614	1 5/16 33.3	2 7/8 73.0	2 50.8	1 1/2 38.1	2 9/16 65.1	1 7/32 31.0	23/32 18.3	1 3/16 30.2	3/8-16	1/2	1.5 .68
7/8	VTBS-214	VS-214	2801 12459	1 7/16 36.5	3 76.2	2 50.8	1 1/2 38.1	2 13/16 71.4	1 3/8 34.9	13/16 20.6	1 3/8 34.9			
15/16	VTBS-215	VS-215		4381 19487	1 11/16 42.9	4 101.6	3 76.2	1 1/2 38.1	3 3/8 85.7	1 1/2 38.1	7/8 22.2	1 19/32 40.5	7/16-14	5/8
1	VTBS-216	VS-216												
1 1/8	VTBS-218	VS-218	5782 25718	1 7/8 47.6	4 1/4 108.0	3 1/4 82.6	1 7/8 47.6	3 3/4 95.3	1 11/16 42.9	1 25.4	1 55/64 47.2	1/2-13	3/4	3.4 1.54
1 3/16	VTBS-219	VS-219												
1 1/4	VTBS-220S	VS-220S	7340 32648	1 15/16 49.2	4 5/8 117.5	3 1/2 88.9	1 7/8 47.6	3 15/16 100.0	1 15/16 49.2	1 3/16 30.2	2 1/16 52.4	1/2-13	3/4	3.8
1 1/4	VTBS-220	VS-220												
1 3/8	VTBS-222	VS-222	7901 35144	2 1/8 54.0	5 127.0	3 3/4 95.3	2 50.8	4 1/4 108.0	1 15/16 49.2	1 3/16 30.2	2 19/64 58.3	1/2-13	3/4	4.7 2.13
1 7/16	VTBS-223	VS-223												
1 1/2	VTBS-224	VS-224	7889 35090	2 1/4 57.2	5 1/2 139.7	4 101.6	2 50.8	4 5/8 117.5	2 1/32 51.6	1 9/32 32.5	2 15/32 62.7	5/8-11	7/8	5.7 2.59
1 1/2	VTBS-224	VS-224												
1 5/8	VTBS-226	VS-226	7901 35144	2 1/8 54.0	5 127.0	3 3/4 95.3	2 50.8	4 1/4 108.0	1 15/16 49.2	1 3/16 30.2	2 19/64 58.3	1/2-13	3/4	4.7 2.13
1 11/16	VTBS-227	VS-227												
1 3/4	VTBS-228	VS-228	7889 35090	2 1/4 57.2	5 1/2 139.7	4 101.6	2 50.8	4 5/8 117.5	2 1/32 51.6	1 9/32 32.5	2 15/32 62.7	5/8-11	7/8	5.7 2.59
1 15/16	VTBS-231	VS-231												
2	VTBS-232S	VS-232S	7889 35090	2 1/4 57.2	5 1/2 139.7	4 101.6	2 50.8	4 5/8 117.5	2 1/32 51.6	1 9/32 32.5	2 15/32 62.7	5/8-11	7/8	5.7 2.59
2	VTBS-232S	VS-232S												

Browning[®] Mounted Ball Bearings



- Duty:** Standard
- Rolling Elements:** Ball
- Housing:** Cast Iron Tapped Base Pillow Block
- Self Alignment:** +/- 1.5 Degrees
- Lock:** Setscrew
- Seal:** Contact and Flinger
- Temperature:** -20° to 200°F

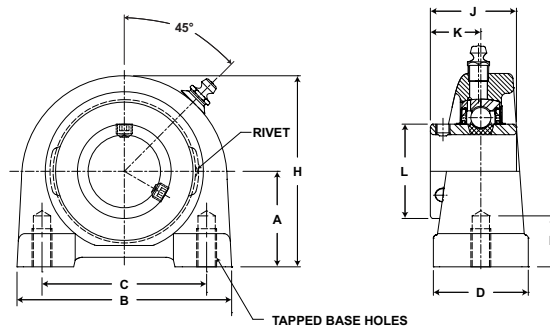

VTBS 200 Series Standard Duty Tapped Base Pillow Blocks - Setscrew Locking - Metric

Bore Diameter mm	Part No.	Bearing Insert No.	Basic Dynamic Rating N/lb	Dimensions mm / inch								Tapped Hole Thread Size	N Min Tap Depth	Unit Wt. kg/lb
				A	B	C	D	H	J	K	L			
20	VTBS-20 MM	VS-20 MM	11614 2611	33.3 1 5/16	73.0 2 7/8	50.8 2	38.1 1 1/2	65.1 2 9/16	31.0 1 7/32	18.3 23/32	30.2 1 3/16	M8	12.7	.68 1.5
25	VTBS-25MM	VS-25MM	12459 2801	36.5 1 7/16	76.2 3	50.8 2	38.1 1 1/2	71.4 2 13/16	34.9 1 3/8	20.6 13/16	34.9 1 3/8	M25	12.7	.73 1.6
30	VTBS-30MM	VS-30MM	19487 4381	42.9 1 11/16	101.6 4	76.2 3	38.1 1 1/2	85.7 3 3/8	38.1 1 1/2	22.2 7/8	40.5 1 19/32	M10	15.9	1.13 2.5
35	VTBS-35MM	VS-35MM	25718 5782	47.6 1 7/8	108.0 4 1/4	82.6 3 1/4	47.6 1 7/8	95.3 3 3/4	42.9 1 11/16	25.4 1	47.2 1 55/64	M10	19.1	1.5 3.4
40	VTBS-40MM	VS-40MM	32648 7340	49.2 1 15/16	117.5 4 5/8	88.9 3 1/2	47.6 1 7/8	100.0 3 15/16	49.2 1 15/16	30.2 1 3/16	52.4 2 1/16	M12	19.1	1.72 3.8
45	VTBS-45MM	VS-45MM	35144 7901	54.0 2 1/8	127.0 5	95.3 3 3/4	50.8 2	108.0 4 1/4	49.2 1 15/16	30.2 1 3/16	58.3 2 19/64	M12	19.1	2.13 4.7
50	VTBS-50MM	VS-50MM	35090 7889	57.2 2 1/4	139.7 5 1/2	101.6 4	50.8 2	117.5 4 5/8	51.6 2 1/32	32.5 1 9/32	62.7 2 15/32	M16	22.2	2.59 5.7

Metric dimensions for reference only.

Not all parts are available from stock. Please contact customer service for availability (800) 626-2120.

For more information on bearing capabilities outside of our standard offering, please contact Application Engineering (800) 626-2093.

Mounted Ball Bearings *Browning*[®]



- Duty:** Standard
- Rolling Elements:** Ball
- Housing:** Cast Iron Tapped Base Pillow Block
- Self Alignment:** +/- 1.5 Degrees
- Lock:** BOA
- Seal:** Contact and Flinger
- Temperature:** -20° to 200°F

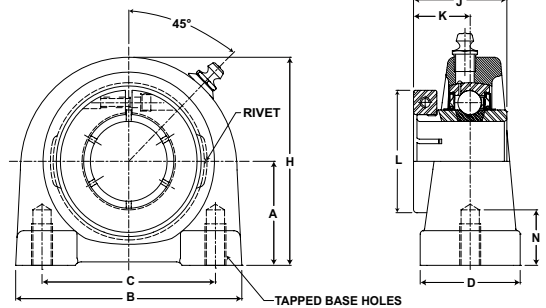

VTBB 200 Series Standard Duty Tapped Base Pillow Blocks - BOA Concentric Locking

Bore Diameter inch	Part No.	Bearing Insert No.	Basic Dynamic Rating lb/N	Dimensions inch / mm								Tapped Hole Thread Size	N Min Tap Depth	Unit Wt. lb/kg
				A	B	C	D	H	J	K	L			
3/4	VTBB-212	VB-212	2611 11614	1 5/16 33.3	2 7/8 73.0	2 50.8	1 1/2 38.1	2 9/16 65.1	1 9/32 32.5	25/32 19.8	1 3/4 44.5	3/8-16	1/2	1.7 .77
7/8	VTBB-214	VB-214	2801 12459	1 7/16 36.5	3 76.2	2 50.8	1 1/2 38.1	2 13/16 71.4	1 7/16 36.5	7/8 22.2	1 15/16 49.2	3/8-16	1/2	1.8 .82
15/16	VTBB-215	VB-215												
1	VTBB-216	VB-216												
1 1/8	VTBB-218	VB-218	4381 19487	1 11/16 42.9	4 101.6	3 76.2	1 1/2 38.1	3 3/8 85.7	1 9/16 39.7	15/16 23.8	2 3/16 55.6	7/16-14	5/8	2.8 1.27
1 3/16	VTBB-219	VB-219												
1 1/4	VTBB-220S	VB-220S												
1 1/4	VTBB-220	VB-220	5782 25718	1 7/8 47.6	4 1/4 108.0	3 1/4 82.6	1 7/8 47.6	3 3/4 95.3	1 3/4 44.5	1 1/16 27.0	2 7/16 61.9	1/2-13	3/4	4.0 1.81
1 3/8	VTBB-222	VB-222	5782 25718	1 7/8 47.6	4 1/4 108.0	3 1/4 82.6	1 7/8 47.6	3 3/4 95.3	1 3/4 44.5	1 1/16 27.0	2 9/16 65.1	1/2-13	3/4	4.0 1.81
1 7/16	VTBB-223	VB-223												
1 1/2	VTBB-224	VB-224	7340 32648	1 15/16 49.2	4 5/8 117.5	3 1/2 88.9	1 7/8 47.6	3 15/16 100.0	2 50.8	1 1/4 31.8	2 11/16 68.3	1/2-13	3/4	4.5 2.04
1 5/8	VTBB-226	VB-226	7901 35144	2 1/8 54.0	5 127.0	3 3/4 95.3	2 50.8	4 1/4 108.0	2 50.8	1 1/4 31.8	2 13/16 71.4	1/2-13	3/4	5.6 2.54
1 11/16	VTBB-227	VB-227	7901 35144	2 1/8 54.0	5 127.0	3 3/4 95.3	2 50.8	4 1/4 108.0	2 50.8	1 1/4 31.8	2 15/16 74.6	1/2-13	3/4	5.6 2.54
1 3/4	VTBB-228	VB-228												
1 15/16	VTBB-231	VB-231	7889 35090	2 1/4 57.2	5 1/2 139.7	4 101.6	2 50.8	4 5/8 117.5	2 3/32 53.2	1 11/32 34.1	3 3/8 85.7	5/8-11	7/8	6.9 3.13
2	VTBB-232S	VB-232S												

Browning[®] Mounted Ball Bearings



- Duty:** Intermediate
- Rolling Elements:** Ball
- Housing:** Cast Iron Four Bolt Flange
- Self Alignment:** +/- 1.5 Degrees
- Lock:** Setscrew
- Seal:** Contact and Flinger
- Temperature:** -20° to 200°F

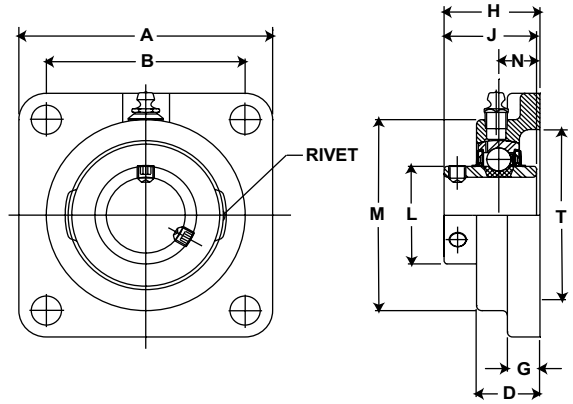

VF4S 100 Series Intermediate Duty Four Bolt Flanges - Setscrew Locking

Bore Diameter inch	Part No.	Bearing Insert No.	Basic Dynamic Rating lb/N	Dimensions inch / mm										Bolt Size	Unit Wt. lb/kg
				A	B*	D	G	H	J	L	M	N	T Cored		
1/2	VF4S-108	VS-108	2108	3	2 1/8	23/32	3/8	1 5/64	15/16	31/32	2 1/8	5/16	1 3/4	3/8	1.0 .45
5/8	VF4S-110	VS-110	9377	76.2	54.0	18.3	9.5	27.4	23.8	24.6	54.0	7.9	44.5		
3/4	VF4S-112	VS-112	2611 11614	3 3/8 85.7	2 1/2 63.5	57/64 22.6	7/16 11.1	1 9/32 32.5	1 1/16 27.0	1 3/16 30.2	2 1/2 63.5	11/32 8.7	2 50.8	3/8	1.3 .59
7/8	VF4S-114	VS-114	2801 12459	3 3/4 95.3	2 3/4 69.9	61/64 24.2	1/2 12.7	1 25/64 35.3	1 7/64 28.2	1 3/8 34.9	2 3/4 69.9	11/32 8.7	2 1/2 63.5		
15/16	VF4S-115	VS-115													
1	VF4S-116	VS-116													
1 1/8	VF4S-118	VS-118	4381 19487	4 1/4 108.0	3 1/4 82.6	1 5/64 27.4	17/32 13.5	1 15/32 37.3	1 5/32 29.4	1 19/32 40.5	3 1/8 79.4	3/8 9.5	2 7/8 73.0	7/16	2.4 1.09
1 3/16	VF4S-119	VS-119													
1 1/4	VF4S-120S	VS-120S													
1 1/4	VF4S-120	VS-120	5782 25718	4 5/8 117.5	3 5/8 92.1	1 5/32 29.4	19/32 15.1	1 39/64 40.9	1 9/32 32.5	1 55/64 47.2	3 5/8 92.1	27/64 10.7	3 1/4 82.6	1/2	3.4 1.54
1 3/8	VF4S-122	VS-122													
1 7/16	VF4S-123	VS-123													
1 1/2	VF4S-124	VS-124	7340 32648	5 1/8 130.2	4 101.6	1 19/64 32.9	5/8 15.9	1 49/64 44.8	1 27/64 36.1	2 1/16 52.4	4 1/8 104.8	31/64 12.3	3 1/2 88.9	1/2	4.4 2.00
1 11/16	VF4S-127	VS-127	7901 35144	5 3/8 136.5	4 1/8 104.8	1 21/64 33.7	5/8 15.9	1 13/16 46.0	1 7/16 36.5	2 19/64 58.3	4 3/8 111.1	31/64 12.3	3 7/8 98.4		
1 3/4	VF4S-128	VS-128													
1 15/16	VF4S-131	VS-131	7889 35090	5 5/8 142.9	4 3/8 111.1	1 23/64 34.5	5/8 15.9	1 59/64 48.8	1 35/64 39.3	2 15/32 62.7	4 9/16 115.9	1/2 12.7	4 101.6	9/16	5.4 2.45
2	VF4S-132S	VS-132S													
2	VF4S-132	VS-132	9752 43377	6 3/8 161.9	5 1/8 130.2	1 33/64 38.5	13/16 20.6	2 7/64 53.6	1 21/32 42.1	2 23/32 69.1	5 1/4 133.4	35/64 13.9	4 1/4 108.0	5/8	7.7 3.49
2 3/16	VF4S-135	VS-135													

* To obtain bolt circle multiply B x 1.414".

Metric dimensions for reference only.
 Not all parts are available from stock. Please contact customer service for availability (800) 626-2120.
 For more information on bearing capabilities outside of our standard offering, please contact Application Engineering (800) 626-2093.

Mounted Ball Bearings *Browning*

Mtd. Ball Bearings



- Duty:** Intermediate
- Rolling Elements:** Ball
- Housing:** Cast Iron Four Bolt Flange
- Self Alignment:** +/- 1.5 Degrees
- Lock:** Eccentric
- Seal:** Contact
- Temperature:** -20° to 200°F

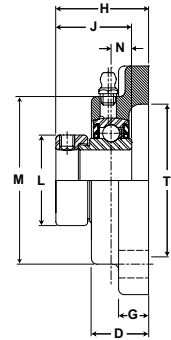
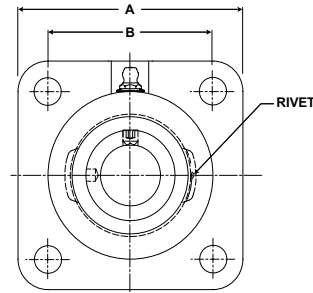

VF4E 100 Series Intermediate Duty Four Bolt Flanges - Eccentric Locking

Bore Diameter inch	Part No.	Bearing Insert No.	Basic Dynamic Rating lb/N	Dimensions inch / mm										Bolt Size	Unit Wt. lb/kg
				A	B*	D	G	H	J	L	M	N	T Cored		
1/2	VF4E-108	VE-108	2108	3	2 1/8	23/32	3/8	1 21/64	1 3/16	1 3/16	2 1/8	5/16	1 3/4	3/8	1.1 .50
5/8	VF4E-110	VE-110	9377	76.2	54.0	18.3	9.5	33.7	30.2	30.2	54.0	7.9	44.5		
3/4	VF4E-112	VE-112	2611 11614	3 3/8 85.7	2 1/2 63.5	57/64 22.6	7/16 11.1	1 31/64 37.7	1 17/64 32.1	1 5/16 33.3	2 1/2 63.5	11/32 8.7	2 50.8	3/8	1.4 .64
7/8	VF4E-114	VE-114	2801 12459	3 3/4	2 3/4	61/64	1/2	1 35/64	1 17/64	1 1/2	2 3/4	11/32	2 1/2		
15/16	VF4E-115	VE-115		95.3	69.9	24.2	12.7	39.3	32.1	38.1	69.9	8.7	63.5		
1	VF4E-116	VE-116	4381 19487	4 1/4 108.0	3 1/4 82.6	1 5/64 27.4	17/32 13.5	1 47/64 44.1	1 27/64 36.1	1 3/4 44.5	3 1/8 79.4	3/8 9.5	2 7/8 73.0	7/16	2.6 1.18
1 1/8	VF4E-118	VE-118													
1 3/16	VF4E-119	VE-119													
1 1/4	VF4E-120S	VE-120S	5782 25718	4 5/8 117.5	3 5/8 92.1	1 5/32 29.4	19/32 15.1	1 29/32 48.4	1 37/64 40.1	2 3/16 55.6	3 5/8 92.1	27/64 10.7	3 1/4 82.6	1/2	3.6 1.63
1 1/4	VF4E-120	VE-120													
1 3/8	VF4E-122	VE-122													
1 7/16	VF4E-123	VE-123													
1 1/2	VF4E-124	VE-124	7340 32648	5 1/8 130.2	4 101.6	1 19/64 32.9	5/8 15.9	2 7/64 53.6	1 49/64 44.8	2 3/8 60.3	4 1/8 104.8	31/64 12.3	3 1/2 88.9	1/2	4.7 2.13
1 11/16	VF4E-127	VE-127													
1 3/4	VF4E-128	VE-128	7901 35144	5 3/8 136.5	4 1/8 104.8	1 21/64 33.7	5/8 15.9	2 9/64 54.4	1 49/64 44.8	2 1/2 63.5	4 3/8 111.1	31/64 12.3	3 7/8 98.4	9/16	5.0 2.27
1 15/16	VF4E-131	VE-131													
2	VF4E-132S	VE-132S	7889 35090	5 5/8 142.9	4 3/8 111.1	1 23/64 34.5	5/8 15.9	2 5/32 54.8	1 25/32 45.2	2 3/4 69.9	4 9/16 115.9	1/2 12.7	4 101.6	9/16	5.6 2.54
2 3/16	VF4E-135	VE-135													
2	VF4E-132	VE-132	9752 43377	6 3/8 161.9	5 1/8 130.2	1 33/64 38.5	13/16 20.6	2 7/16 61.9	1 63/64 50.4	3 76.2	5 1/4 133.4	35/64 13.9	4 1/4 108.0	5/8	7.7 3.49
2 3/16	VF4E-135	VE-135													

* To obtain bolt circle multiply B x 1.414".



- Duty:** Standard
- Rolling Elements:** Ball
- Housing:** Cast Iron Four Bolt Flange
- Self Alignment:** +/- 1.5 Degrees
- Lock:** Setscrew
- Seal:** Contact and Flinger
- Temperature:** -20° to 200°F

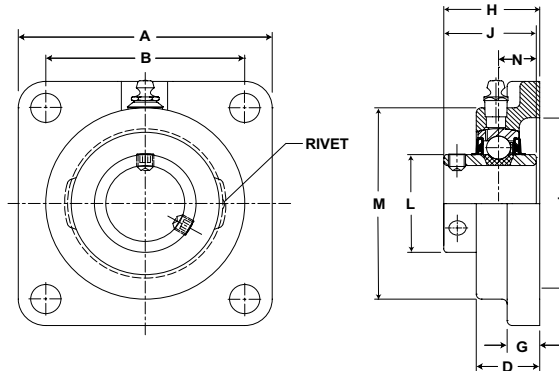

VF4S 200 Series Standard Duty Four Bolt Flanges - Setscrew Locking - Inch

Bore Diameter		Part No.	Bearing Insert No.	Basic Dynamic Rating lb/N	Dimensions inch / mm										Bolt Size	Unit Wt. lb/kg
inch	mm				A	B*	D	G	H	J	L	M	N	T Cored		
1/2	12.7	VF4S-208	VS-208	2108	3	2 1/8	23/32	3/8	1 5/64	1 1/32	31/32	2 1/8	13/32	1 3/4	3/8	1.1
5/8	15.9	VF4S-210	VS-210	9377	76.2	54.0	18.3	9.5	27.4	26.2	24.6	54.0	10.3	44.5	3/8	.50
3/4	19.1	VF4S-212	VS-212	2611 11614	3 3/8	2 1/2	57/64	7/16	1 9/32	1 7/32	1 3/16	2 1/2	1/2	2	3/8	1.4
7/8	22.2	VF4S-214	VS-214	2801	3 3/4	2 3/4	61/64	1/2	1 7/16	1 3/8	1 3/8	2 3/4	9/16	2 1/2	7/16	1.6
15/16	23.8	VF4S-215	VS-215	12459	95.3	69.9	24.2	12.7	36.5	34.9	34.9	69.9	14.3	63.5	7/16	.73
1	25.4	VF4S-216	VS-216													
1 1/8	28.6	VF4S-218	VS-218	4381	4 1/4	3 1/4	1 5/64	17/32	1 9/16	1 1/2	1 19/32	3 1/8	5/8	2 7/8	7/16	2.6
1 3/16	30.2	VF4S-219	VS-219	19487	108.0	82.6	27.4	13.5	39.7	38.1	40.5	79.4	15.9	73.0	7/16	1.18
1 1/4	31.8	VF4S-220S	VS-220S													
1 1/4	31.8	VF4S-220	VS-220	5782	4 5/8	3 5/8	1 5/32	19/32	1 3/4	1 11/16	1 55/64	3 5/8	11/16	3 1/4	1/2	3.6
1 3/8	34.9	VF4S-222	VS-222	25718	117.5	92.1	29.4	15.1	44.5	42.9	47.2	92.1	17.5	82.6	1/2	1.63
1 7/16	36.5	VF4S-223	VS-223													
1 1/2	38.1	VF4S-224	VS-224	7340 32648	5 1/8	4	1 19/64	5/8	2 1/64	1 15/16	2 1/16	4 1/8	3/4	3 1/2	1/2	4.9
					130.2	101.6	32.9	15.9	51.2	49.2	52.4	104.8	19.1	88.9	1/2	2.22
1 5/8	41.3	VF4S-226	VS-226	7901	5 3/8	4 1/8	1 21/64	5/8	2 3/64	1 15/16	2 19/64	4 3/8	3/4	3 7/8	9/16	5.2
1 11/16	42.9	VF4S-227	VS-227	35144	136.5	104.8	33.7	15.9	52.0	49.2	58.3	111.1	19.1	98.4	9/16	2.36
1 3/4	44.5	VF4S-228	VS-228													
1 15/16	49.2	VF4S-231	VS-231	7889	5 5/8	4 3/8	1 23/64	5/8	2 5/32	2 1/32	2 15/32	4 9/16	3/4	4	9/16	5.6
2	50.8	VF4S-232S	VS-232S	35090	142.9	111.1	34.5	15.9	54.8	51.6	62.7	115.9	19.1	101.6	9/16	2.54
2	50.8	VF4S-232	VS-232	9752	6 3/8	5 1/8	1 33/64	13/16	2 5/16	2 3/16	2 23/32	5 1/4	7/8	4 1/4	5/8	7.9
2 3/16	55.6	VF4S-235	VS-235	43377	161.9	130.2	38.5	20.6	58.7	55.6	69.1	133.4	22.2	108.0	5/8	3.58
2 1/4	57.2	VF4S-236	VS-236	11789	6 7/8	5 5/8	1 11/16	13/16	2 11/16	2 3/16	2 63/64	5 7/16	1	5	5/8	9.6
2 7/16	61.9	VF4S-239	VS-239	52437	174.6	142.9	42.9	20.6	68.3	55.6	75.8	138.1	25.4	127.0	5/8	4.35

* To obtain bolt circle multiply B x 1.414".

Metric dimensions for reference only.

Not all parts are available from stock. Please contact customer service for availability (800) 626-2120.

For more information on bearing capabilities outside of our standard offering, please contact Application Engineering (800) 626-2093.

Mounted Ball Bearings *Browning*



- Duty:** Standard
- Rolling Elements:** Ball
- Housing:** Cast Iron Four Bolt Flange
- Self Alignment:** +/- 1.5 Degrees
- Lock:** Setscrew
- Seal:** Contact and Flinger
- Temperature:** -20° to 200°F

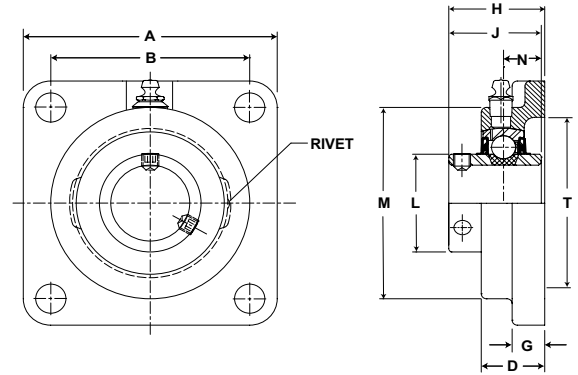

VF4S 200 Series Standard Duty Four Bolt Flanges - Setscrew Locking - Metric

Bore Diameter mm	Part No.	Bearing Insert No.	Basic Dynamic Rating N/lb	Dimensions mm / inch										Bolt Size	Unit Wt. kg/lb
				A	B*	D	G	H	J	L	M	N	T Cored		
20	VF4S-20 MM	VS-20 MM	11614 2611	85.7 3 3/8	63.5 2 1/2	22.6 5/8	11.1 7/16	32.5 1 9/32	31.0 1 7/32	30.2 1 3/16	63.5 2 1/2	12.7 1/2	50.8 2	M10	.64 1.4
25	VF4S-25 MM	VS-25 MM	12459 2801	95.3 3 3/4	69.9 2 3/4	24.2 1 1/2	12.7 1/2	36.5 1 7/16	34.9 1 3/8	34.9 1 3/8	69.9 2 3/4	14.3 9/16	63.5 2 1/2	M10	.73 1.6
30	VF4S-30 MM	VS-30 MM	19487 4381	108.0 4 1/4	82.6 3 1/4	27.4 1 5/8	13.5 1/2	39.7 1 9/16	38.1 1 1/2	40.5 1 19/32	79.4 3 1/8	15.9 5/8	73.0 2 7/8	M10	1.18 2.6
35	VF4S-35 MM	VS-35 MM	25718 5782	117.5 4 5/8	92.1 3 5/8	29.4 1 5/8	15.1 1/2	44.5 1 9/32	42.9 1 11/16	47.2 1 55/64	92.1 3 5/8	17.5 11/16	82.6 3.25	M12	1.63 3.6
40	VF4S-40 MM	VS-40 MM	32648 7340	130.2 5 1/8	101.6 4	32.9 1 19/64	15.9 5/8	51.2 2 1/64	49.2 1 15/16	52.4 2 1/16	104.8 4 1/8	19.1 3/4	88.9 3 1/2	M12	2.22 4.9
45	VF4S-45 MM	VS-45 MM	35144 7901	136.5 5 3/8	104.8 4 1/8	33.7 1 21/64	15.9 5/8	52.0 2 3/64	49.2 1 15/16	58.3 2 19/64	111.1 4 3/8	19.1 3/4	98.4 3 7/8	M14	2.36 5.2
50	VF4S-50 MM	VS-50 MM	35090 7889	142.9 5 5/8	111.1 4 3/8	34.5 1 23/64	15.9 5/8	54.8 2 5/32	51.6 2 1/32	62.7 2 15/32	115.9 4 9/16	19.1 3/4	101.6 4	M16	2.54 5.6
55	VF4S-55 MM	VS-55 MM	43377 9752	161.9 6 3/8	130.2 5 1/8	38.5 1 33/64	20.6 13/16	58.7 2 5/16	55.6 2 3/16	69.1 2 23/32	133.4 5 1/4	22.2 7/8	108.0 4 1/4	M16	3.58 7.9
60	VF4S-60 MM	VS-60 MM	52437 11789	174.6 6 7/8	142.9 5 5/8	42.9 1 11/16	20.6 13/16	68.3 2 11/16	55.6 2 3/16	75.8 2 63/64	138.1 5 7/16	25.4 1	127.0 5	M16	4.35 9.6

* To obtain bolt circle multiply B x 1.414".



Duty: Standard
Rolling Elements: Ball
Housing: Cast Iron Four Bolt Flange
Self Alignment: +/- 1.5 Degrees
Lock: BOA Concentric
Seal: Contact and Flinger
Temperature: -20° to 200°F

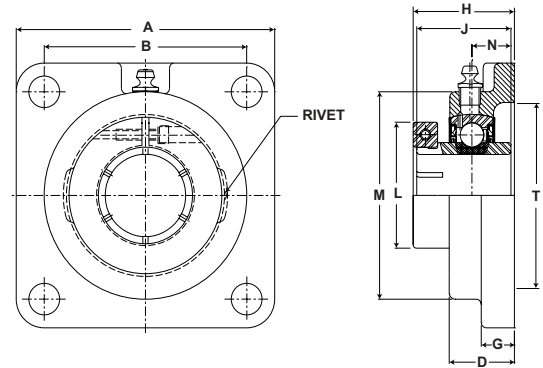

VF4B 200 Series Standard Duty Four Bolt Flanges - BOA Concentric Locking

Bore Diameter inch	Part No.	Bearing Insert No.	Basic Dynamic Rating lb/N	Dimensions inch / mm										Bolt Size	Unit Wt. lb/kg
				A	B*	D	G	H	J	L	M	N	T Cored		
3/4	VF4B-212	VB-212	2611 11614	3 3/8 85.7	2 1/2 63.5	57/64 22.6	7/16 11.1	1 11/32 34.1	1 9/32 32.5	1 3/4 44.5	2 1/2 63.5	1/2 12.7	2 50.8	3/8	1.5 .68
7/8	VF4B-214	VB-214	2801	3 3/4	2 3/4	61/64	1/2	1 1/2	1 7/16	1 15/16	2 3/4	9/16	2 1/2	7/16	1.8 .82
15/16	VF4B-215	VB-215	12459	95.3	69.9	24.2	12.7	38.1	36.5	49.2	69.9	14.3	63.5		
1	VF4B-216	VB-216													
1 1/8	VF4B-218	VB-218	4381	4 1/4	3 1/4	1 5/64	17/32	1 5/8	1 9/16	2 3/16	3 1/8	5/8	2 7/8	7/16	2.8 1.27
1 3/16	VF4B-219	VB-219	19487	108.0	82.6	27.4	13.5	41.3	39.7	55.6	79.4	15.9	73.0		
1 1/4	VF4B-220S	VB-220S													
1 1/4	VF4B-220	VB-220	5782 25718	4 5/8 117.5	3 5/8 92.1	1 5/32 29.4	19/32 15.1	1 13/16 46.0	1 3/4 44.5	2 7/16 61.9	3 5/8 92.1	11/16 17.5	3 1/4 82.6	1/2	3.9 1.77
1 3/8	VF4B-222	VB-222	5782	4 5/8	3 5/8	1 5/32	19/32	1 13/16	1 3/4	2 9/16	3 5/8	11/16	3 1/4	1/2	3.9 1.77
1 7/16	VF4B-223	VB-223	25718	117.5	92.1	29.4	15.1	46.0	44.5	65.1	92.1	17.5	82.6		
1 1/2	VF4B-224	VB-224	7340 32648	5 1/8 130.2	4 101.6	1 19/64 32.9	5/8 15.9	2 5/64 52.8	2 50.8	2 11/16 68.3	4 1/8 104.8	3/4 19.1	3 1/2 88.9	1/2	5.2 2.36
1 5/8	VF4B-226	VB-226	7901 35144	5 3/8 136.5	4 1/8 104.8	1 21/64 33.7	5/8 15.9	2 7/64 53.6	2 50.8	2 13/16 71.4	4 3/8 111.1	3/4 19.1	3 7/8 98.4	9/16	5.5 2.49
1 11/16	VF4B-227	VB-227	7901	5 3/8	4 1/8	1 21/64	5/8	2 7/64	2	2 15/16	4 3/8	3/4	3 7/8	9/16	5.5 2.49
1 3/4	VF4B-228	VB-228	35144	136.5	104.8	33.7	15.9	53.6	50.8	74.6	111.1	19.1	98.4		
1 15/16	VF4B-231	VB-231	7889	5 5/8	4 3/8	1 23/64	5/8	2 7/32	2 3/32	3 3/8	4 9/16	3/4	4	9/16	6.2 2.81
2	VF4B-232S	VB-232S	35090	142.9	111.1	34.5	15.9	56.4	53.2	85.7	115.9	19.1	101.6		
2	VF4B-232	VB-232	9752 43377	6 3/8 161.9	5 1/8 130.2	1 33/64 38.5	13/16 20.6	2 3/8 60.3	2 1/4 57.2	3 1/2 88.9	5 1/4 133.4	7/8 22.2	4 1/4 108.0	5/8	8.5 3.86
2 3/16	VF4B-235	VB-235	9752 43377	6 3/8 161.9	5 1/8 130.2	1 33/64 38.5	13/16 20.6	2 3/8 60.3	2 1/4 57.2	3 5/8 92.1	5 1/4 133.4	7/8 22.2	4 1/4 108.0	5/8	8.5 3.86
2 1/4	VF4B-236	VB-236	11789 52437	6 7/8 174.6	5 5/8 142.9	1 11/16 42.9	13/16 20.6	2 3/4 69.9	2 5/8 66.7	4 1/16 103.2	5 7/16 138.1	1 25.4	5 127.0	5/8	10.8 4.90
2 7/16	VF4B-239	VB-239	11789 52437	6 7/8 174.6	5 5/8 142.9	1 11/16 42.9	13/16 20.6	2 3/4 69.9	2 5/8 66.7	4 1/8 104.8	5 7/16 138.1	1 25.4	5 127.0	5/8	10.8 4.90

* To obtain bolt circle multiply B x 1.414".

Metric dimensions for reference only.

Not all parts are available from stock. Please contact customer service for availability (800) 626-2120.

For more information on bearing capabilities outside of our standard offering, please contact Application Engineering (800) 626-2093.

Mounted Ball Bearings *Browning*



- Duty:** Standard
- Rolling Elements:** Ball
- Housing:** Cast Iron Four Bolt Flange
- Self Alignment:** +/- 1.5 Degrees
- Lock:** Eccentric
- Seal:** Contact and Flinger
- Temperature:** -20° to 200°F

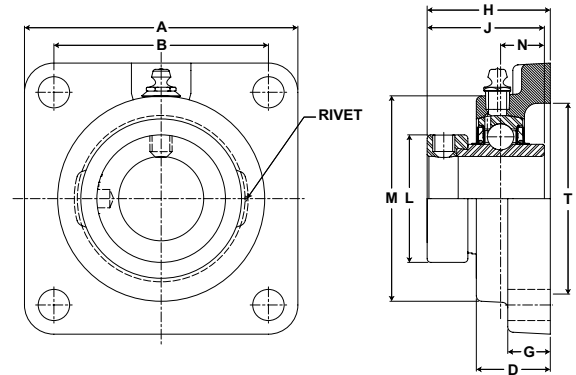

VF4E 200 Series Standard Duty Four Bolt Flanges - Eccentric Locking

Bore Diameter inch	Part No.	Bearing Insert No.	Basic Dynamic Rating lb/N	Dimensions inch / mm										Bolt Size	Unit Wt. lb/kg
				A	B*	G	D	H	J	L	M	N	T Cored		
1/2	VF4E-208	VE-208	2108	3	2 1/8	1/2	7/8	1 33/64	1 15/32	1 3/16	2 1/8	35/64	1 3/4	3/8	1.2 .54
5/8	VF4E-210	VE-210	9377	76.2	54.0	12.7	22.2	38.5	37.3	30.2	54.0	13.9	44.5		
3/4	VF4E-212	VE-212	2611 11614	3 3/8	2 1/2	1/2	1 5/64	1 51/64	1 23/32	1 5/16	2 1/2	43/64	2	3/8	1.5 .68
7/8	VF4E-214	VE-214	2801	3 3/4	2 3/4	9/16	1 7/64	1 27/32	1 3/4	1 1/2	2 3/4	11/16	2 1/2		
15/16	VF4E-215	VE-215	12459	95.3	69.9	14.3	28.2	46.8	44.5	38.1	69.9	17.5	63.5	7/16	2.0 .91
1	VF4E-216	VE-216													
1 1/8	VF4E-218	VE-218	4381	4 1/4	3 1/4	5/8	1 13/64	2	1 29/32	1 3/4	3 1/8	23/32	2 7/8	7/16	3.0 1.36
1 3/16	VF4E-219	VE-219	19487	108.0	82.6	15.9	30.6	50.8	48.4	44.5	79.4	18.3	73.0		
1 1/4	VF4E-220S	VE-220S													
1 1/4	VF4E-220	VE-220	5782	4 5/8	3 5/8	21/32	1 1/4	2 1/8	2 1/64	2 3/16	3 5/8	3/4	3 1/4	1/2	3.8 1.72
1 3/8	VF4E-222	VE-222	25718	117.5	92.1	16.7	31.8	54.0	51.2	55.6	92.1	19.1	82.6		
1 7/16	VF4E-223	VE-223													
1 1/2	VF4E-224	VE-224	7340 32648	5 1/8	4	11/16	1 13/32	2 5/16	2 7/32	2 3/8	4 1/8	27/32	3 1/2	1/2	5.1 2.31
1 5/8	VF4E-226	VE-226	7901	5 3/8	4 1/8	11/16	1 13/32	2 5/16	2 7/32	2 1/2	4 3/8	27/32	3 7/8		
1 11/16	VF4E-227	VE-227	35144	136.5	104.8	17.5	35.7	58.7	56.4	63.5	111.1	21.4	98.4	9/16	5.4 2.45
1 3/4	VF4E-228	VE-228													
1 15/16	VF4E-231	VE-231	7889 35090	5 5/8	4 3/8	23/32	1 39/64	2 5/8	2 15/32	2 3/4	4 9/16	31/32	4	9/16	5.9 2.68
2	VF4E-232	VE-232	9752	6 3/8	5 1/8	25/32	1 49/64	2 31/32	2 13/16	3	5 1/4	1 3/32	4 1/4		
2 3/16	VF4E-235	VE-235	43377	161.9	130.2	19.8	44.8	75.4	71.4	76.2	133.4	27.8	108.0	5/8	8.2 3.72
2 1/4	VF4E-236	VE-236	11789	6 7/8	5 5/8	13/16	1 31/32	3 1/4	3 1/16	3 3/8	5 7/16	1 7/32	4 7/8		
2 7/16	VF4E-239	VE-239	52437	174.6	142.9	20.6	50.0	82.6	77.8	85.7	138.1	31.0	123.8	5/8	9.9 4.49

* To obtain bolt circle multiply B x 1.414".

Browning[®] Mounted Ball Bearings



- Duty:** Medium
- Rolling Elements:** Ball
- Housing:** Cast Iron Four Bolt Flange
- Self Alignment:** +/- 1.5 Degrees
- Lock:** Setscrew
- Seal:** Contact and Flinger
- Temperature:** -20° to 200°F

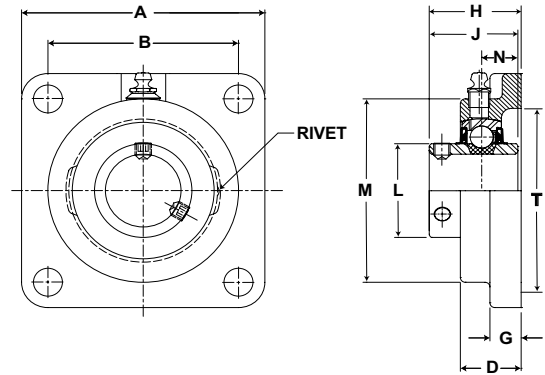

VF4S 300 Series Medium Duty Four Bolt Flanges - Setscrew Locking

Bore Diameter inch	Part No.	Bearing Insert No.	Basic Dynamic Rating lb/N	Dimensions inch / mm										Bolt Size	Unit Wt. lb/kg
				A	B	D	G	H	J	L	M	N	T Cored		
1	VF4S-316	VS-316	4381 19487	4 1/4 108.0	3 1/4 82.6	1 5/64 27.4	17/32 13.5	1 9/16 39.7	1 1/2 38.1	1 19/32 40.5	3 1/8 79.4	5/8 15.9	2 7/8 73.0	7/16	2.9 1.32
1 3/16	VF4S-319	VS-319	5782 25718	4 5/8 117.5	3 5/8 92.1	1 5/32 29.4	19/32 15.1	1 3/4 44.5	1 11/16 42.9	1 55/64 47.2	3 5/8 92.1	11/16 17.5	3 1/4 82.6	1/2	2.9 1.32
1 7/16	VF4S-323	VS-323	7340 32648	5 1/8 130.2	4 101.6	1 19/64 32.9	5/8 15.9	2 1/64 51.2	1 15/16 49.2	2 1/16 52.4	4 1/8 104.8	3/4 19.1	3 1/2 88.9	1/2	5.0 2.27
1 1/2	VF4S-324	VS-324	7901 35144	5 3/8 136.5	4 1/8 104.8	1 21/64 33.7	5/8 15.9	2 3/64 52.0	1 15/16 49.2	2 19/64 58.3	4 3/8 111.1	3/4 19.1	3 7/8 98.4	9/16	5.0 2.27
1 11/16	VF4S-327	VS-327	7889	5 5/8 142.9	4 3/8 111.1	1 23/64 34.5	5/8 15.9	2 5/32 54.8	2 1/32 51.6	2 15/32 62.7	4 9/16 115.9	3/4 19.1	4 101.6	9/16	5.8 2.63
1 3/4	VF4S-328	VS-328	35090	6 3/8 161.9	5 1/8 130.2	1 33/64 38.5	13/16 20.6	2 5/16 58.7	2 3/16 55.6	2 23/32 69.1	5 1/4 133.4	7/8 22.2	4 1/4 108.0	5/8	8.0 3.63
1 15/16	VF4S-331	VS-331	9752	6 3/8 161.9	5 1/8 130.2	1 33/64 38.5	13/16 20.6	2 5/16 58.7	2 3/16 55.6	2 23/32 69.1	5 1/4 133.4	7/8 22.2	4 1/4 108.0	5/8	8.0 3.63
2	VF4S-332	VS-232S	43377	6 3/8 161.9	5 1/8 130.2	1 33/64 38.5	13/16 20.6	2 5/16 58.7	2 3/16 55.6	2 23/32 69.1	5 1/4 133.4	7/8 22.2	4 1/4 108.0	5/8	8.0 3.63
2 3/16	VF4S-335	VS-335	11789	6 7/8 174.6	5 5/8 142.9	1 11/16 42.9	13/16 20.6	2 11/16 68.3	2 9/16 65.1	2 63/64 75.8	5 7/16 138.1	1 25.4	5 127.0	5/8	9.9 4.49
2 1/4	VF4S-336	VS-236	52437	6 7/8 174.6	5 5/8 142.9	1 11/16 42.9	13/16 20.6	2 11/16 68.3	2 9/16 65.1	2 63/64 75.8	5 7/16 138.1	1 25.4	5 127.0	5/8	9.9 4.49

* To obtain bolt circle multiply B x 1.414"

Metric dimensions for reference only.

Mounted Ball Bearings *Browning*



- Duty:** Medium
- Rolling Elements:** Ball
- Housing:** Cast Iron Four Bolt Flange
- Self Alignment:** +/- 1.5 Degrees
- Lock:** BOA Concentric
- Seal:** Contact and Flinger
- Temperature:** -20° to 200°F

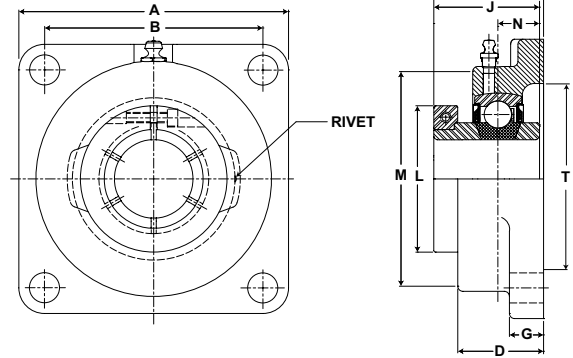

VF4B 300 Series Medium Duty Four Bolt Flanges - BOA Concentric Locking

Bore Diameter inch	Part No.	Bearing Insert No.	Basic Dynamic Rating lb/N	Dimensions inch / mm										Bolt Size	Unit Wt. lb/kg
				A	B*	D	G	H	J	L	M	N	T Cored		
1	VF4B-316	VB-316	4381 19487	4 1/4 108.0	3 1/4 82.6	1 5/64 27.4	17/32 13.5	1 5/8 41.3	1 9/16 39.7	2 1/16 52.4	3 1/8 79.4	5/8 15.9	2 7/8 73.0	7/16	3.0 1.36
1 3/16	VF4B-319	VB-319	5782	4 5/8	3 5/8	1 5/32	19/32	1 13/16	1 3/4	2 7/16	3 5/8	11/16	3 1/4	1/2	3.0 1.36
1 1/4	VF4B-320	VB-220	25718	117.5	92.1	29.4	15.1	46.0	44.5	61.9	92.1	17.5	82.6		
1 7/16	VF4B-323	VB-323	7340 32648	5 1/8 130.2	4 101.6	1 19/64 32.9	5/8 15.9	2 5/64 52.8	2 50.8	2 11/16 68.3	4 1/8 104.8	3/4 19.1	3 1/2 88.9	1/2	5.1 2.31
1 8/16	VF4B-324	VB-324	7901 35144	5 3/8 136.5	4 1/8 104.8	1 21/64 33.7	5/8 15.9	2 7/64 53.6	2 50.8	2 13/16 71.4	4 3/8 111.1	3/4 19.1	3 7/8 98.4	9/16	5.1 2.31
1 11/16	VF4B-327	VB-327	7889	5 5/8	4 3/8	1 23/64	5/8	2 7/32	2 3/32	7 3/4	4 9/16	3/4	4	9/16	5.9 2.68
1 3/4	VF4B-328	VB-328	35090	142.9	111.1	34.5	15.9	56.4	53.2	196.9	115.9	19.1	101.6		
1 15/16	VF4B-331	VB-331	9752	6 3/8	5 1/8	1 33/64	13/16	2 3/8	2 1/4	3 1/2	5 1/4	7/8	4 1/4	5/8	8.2 3.72
2	VF4B-332	VB-232S	43377	161.9	130.2	38.5	20.6	60.3	57.2	88.9	133.4	22.2	108.0		
2 3/16	VF4B-335	VB-335	11789 52437	6 7/8 174.6	5 5/8 142.9	1 11/16 42.9	13/16 20.6	2 3/4 69.9	2 5/8 66.7	4 1/16 103.2	5 7/16 138.1	1 25.4	5 127.0	5/8	10.2 4.63

* To obtain bolt circle multiply B x 1.414".

Browning®

Mounted Ball Bearings



Duty: Intermediate
Rolling Elements: Ball
Housing: Cast Iron Two Bolt Flange
Self Alignment: +/- 1.5 Degrees
Lock: Setscrew
Seal: Contact
Temperature: -20° to 200°F

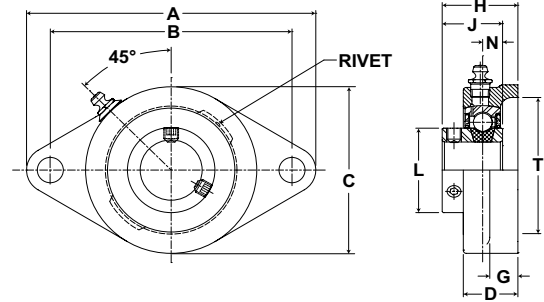

VF2S 100 Series Intermediate Duty Two Bolt Flanges - Setscrew Locking

Bore Diameter inch	Part No.	Bearing Insert No.	Basic Dynamic Rating lb/N	Dimensions inch / mm										Bolt Size	Unit Wt. lb/kg
				A	B	C	D	G	H	J	L	N	T Cored		
1/2	VF2S-108	VS-108	2108	3 7/8	3	2 1/8	23/32	3/8	1 5/64	15/16	31/32	5/16	1 3/4	3/8	.8 .36
5/8	VF2S-110	VS-110	9377	98.4	76.2	54.0	18.3	9.5	27.4	23.8	24.6	7.9	44.5		
3/4	VF2S-112	VS-112	2611 11614	4 13/32	3 17/32	2 1/2	57/64	7/16	1 9/32	1 1/16	1 3/16	11/32	2	3/8	.9 .41
7/8	VF2S-114	VS-114	2801	4 7/8	3 57/64	2 3/4	61/64	1/2	1 25/64	1 7/64	1 3/8	11/32	2 5/16		
15/16	VF2S-115	VS-115	12459	123.8	98.8	69.9	24.2	12.7	35.3	28.2	34.9	8.7	58.7	7/16	1.0 .45
1	VF2S-116	VS-116													
1 1/8	VF2S-118	VS-118	4381 19487	5 9/16	4 19/32	3 1/8	1 5/64	17/32	1 15/32	1 5/32	1 19/32	3/8	2 3/4	7/16	1.6 .73
1 3/16	VF2S-119	VS-119		141.3	116.7	79.4	27.4	13.5	37.3	29.4	40.5	9.5	69.9		
1 1/4	VF2S-120S	VS-120S													
1 1/4	VF2S-120	VS-120	5782 25718	6 1/8	5 1/8	3 5/8	1 5/32	19/32	1 39/64	1 9/32	1 55/64	27/64	3 3/16	1/2	2.6 1.18
1 3/8	VF2S-122	VS-122		155.6	130.2	92.1	29.4	15.1	40.9	32.5	47.2	10.7	81.0		
1 7/16	VF2S-123	VS-123													
1 1/2	VF2S-124	VS-124	7340 32648	6 3/4	5 21/32	4 1/8	1 19/64	5/8	1 49/64	1 27/64	2 1/16	31/64	3 1/2	1/2	3.4 1.54
1 11/16	VF2S-127	VS-127	7901	7 1/16	5 27/32	4 3/8	1 21/64	5/8	1 13/16	1 7/16	2 19/64	31/64	3 3/4		
1 3/4	VF2S-128	VS-128	35144	179.4	148.4	111.1	33.7	15.9	46.0	36.5	58.3	12.3	95.3	9/16	3.5 1.59
1 15/16	VF2S-131	VS-131	7889	7 7/16	6 3/16	4 9/16	1 23/64	5/8	1 59/64	1 35/64	2 15/32	1/2	4		
2	VF2S-132S	VS-132S	35090	188.9	157.2	115.9	34.5	15.9	48.8	39.3	62.7	12.7	101.6	9/16	4.4 2.00
2	VF2S-132	VS-132	9752	8 1/2	7 1/4	5 1/4	1 33/64	13/16	2 7/64	1 21/32	2 23/32	35/64	4 1/4		
2 3/16	VF2S-135	VS-135	43377	215.9	184.2	133.4	38.5	20.6	53.6	42.1	69.1	13.9	108.0	5/8	5.7 2.59

Metric dimensions for reference only.

Not all parts are available from stock. Please contact customer service for availability (800) 626-2120.

For more information on bearing capabilities outside of our standard offering, please contact Application Engineering (800) 626-2093.

Mounted Ball Bearings *Browning*

Mtd. Ball Bearings



- Duty:** Intermediate
- Rolling Elements:** Ball
- Housing:** Cast Iron Two Bolt Flange
- Self Alignment:** +/- 1.5 Degrees
- Lock:** Eccentric
- Seal:** Contact
- Temperature:** -20° to 200°F

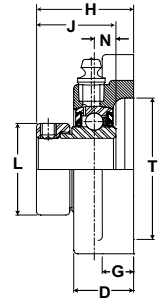
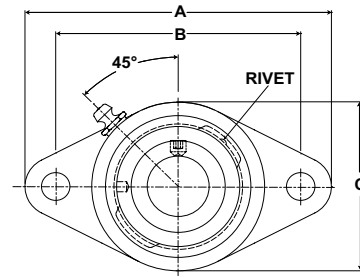

VF2E 100 Series Intermediate Duty Two Bolt Flanges - Eccentric Locking

Bore Diameter inch	Part No.	Bearing Insert No.	Basic Dynamic Rating lb/N	Dimensions inch / mm										Bolt Size	Unit Wt. lb/kg
				A	B	C	D	G	H	J	L	N	T Cored		
1/2	VF2E-108	VE-108	2108	3 7/8	3	2 1/8	23/32	3/8	1 21/64	1 3/16	1 3/16	5/16	1 3/4	3/8	1.0 .45
5/8	VF2E-110	VE-110	9377	98.4	76.2	54.0	18.3	9.5	33.7	30.2	30.2	7.9	44.5		
3/4	VF2E-112	VE-112	2611 11614	4 13/32	3 17/32	2 1/2	57/64	7/16	1 31/64	1 17/64	1 5/16	11/32	2	3/8	1.1 .50
				111.9	89.7	63.5	22.6	11.1	37.7	32.1	33.3	8.7	50.8		
7/8	VF2E-114	VE-114	2801 12459	4 7/8	3 57/64	2 3/4	61/64	1/2	1 35/64	1 17/64	1 1/2	11/32	2 5/16	7/16	1.5 .68
15/16	VF2E-115	VE-115		123.8	98.8	69.9	24.2	12.7	39.3	32.1	38.1	8.7	58.7		
1	VF2E-116	VE-116													
1 1/8	VF2E-118	VE-118	4381 19487	5 9/16	4 19/32	3 1/8	1 5/64	17/32	1 47/64	1 27/64	1 3/4	3/8	2 3/4	7/16	1.9 .86
1 3/16	VF2E-119	VE-119		141.3	116.7	79.4	27.4	13.5	44.1	36.1	44.5	9.5	69.9		
1 1/4	VF2E-120S	VE-120S													
1 1/4	VF2E-120	VE-120	5782 25718	6 1/8	5 1/8	3 5/8	1 5/32	19/32	1 29/32	1 37/64	2 3/16	27/64	3 3/16	1/2	2.8 1.27
1 3/8	VF2E-122	VE-122		155.6	130.2	92.1	29.4	15.1	48.4	40.1	55.6	10.7	81.0		
1 7/16	VF2E-123	VE-123													
1 1/2	VF2E-124	VE-124	7340 32648	6 3/4	5 21/32	4 1/8	1 19/64	5/8	2 7/64	1 49/64	2 3/8	31/64	3 1/2	1/2	3.6 1.63
				171.5	143.7	104.8	32.9	15.9	53.6	44.8	60.3	12.3	88.9		
1 11/16	VF2E-127	VE-127	7901	7 1/16	5 27/32	4 3/8	1 21/64	5/8	2 5/32	1 49/64	2 1/2	31/64	3 3/4	9/16	3.8 1.72
1 3/4	VF2E-128	VE-128	35144	179.4	148.4	111.1	33.7	15.9	54.8	44.8	63.5	12.3	95.3		
1 15/16	VF2E-131	VE-131	7889	7 7/16	6 3/16	4 9/16	1 23/64	5/8	2 5/32	1 25/32	2 3/4	1/2	4	9/16	4.5 2.04
2	VF2E-132S	VE-132S	35090	188.9	157.2	115.9	34.5	15.9	54.8	45.2	69.9	12.7	101.6		
2	VF2E-132	VE-132	9752	8 1/2	7 1/4	5 1/4	1 33/64	13/16	2 7/16	1 63/64	3	35/64	4 1/4	5/8	6.1 2.77
2 3/16	VF2E-135	VE-135	43377	215.9	184.2	133.4	38.5	20.6	61.9	50.4	76.2	13.9	108.0		

Browning[®] Mounted Ball Bearings



- Duty:** Standard
- Rolling Elements:** Ball
- Housing:** Cast Iron Two Bolt Flange
- Self Alignment:** +/- 1.5 Degrees
- Lock:** Setscrew
- Seal:** Contact and Flinger
- Temperature:** -20° to 200°F

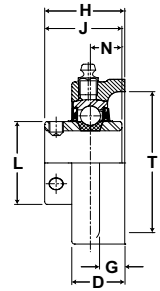
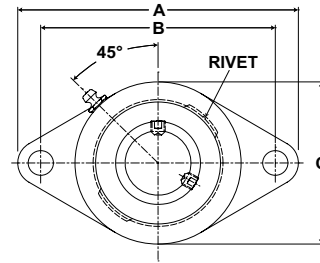

VF2S 200 Series Standard Duty Two Bolt Flanges - Setscrew Locking - Inch

Bore Diameter inch	Part No.	Bearing Insert No.	Basic Dynamic Rating lb/N	Dimensions inch / mm										Bolt Size	Unit Wt. lb/kg
				A	B	C	D	G	H	J	L	N	T Cored		
1/2	VF2S-208	VS-208	2108	3 7/8	3	2 1/8	23/32	3/8	1 5/64	1 1/32	31/32	13/32	1 3/4	3/8	.9
5/8	VF2S-210	VS-210	9377	98.4	76.2	54.0	18.3	9.5	27.4	26.2	24.6	10.3	44.5		.41
3/4	VF2S-212	VS-212	2611 11614	4 13/32 111.9	3 17/32 89.7	2 1/2 63.5	57/64 22.6	7/16 11.1	1 9/32 32.5	1 7/32 31.0	1 3/16 30.2	1/2 12.7	2 50.8	3/8	1.0 .45
7/8	VF2S-214	VS-214	2801	4 7/8	3 57/64	2 3/4	61/64	1/2	1 7/16	1 3/8	1 3/8	9/16	2 5/16		7/16
15/16	VF2S-215	VS-215	12459	123.8	98.8	69.9	24.2	12.7	36.5	34.9	34.9	14.3	58.7	.50	
1	VF2S-216	VS-216													
1 1/8	VF2S-218	VS-218	4381	5 9/16	4 19/32	3 1/8	1 5/64	17/32	1 9/16	1 1/2	1 19/32	5/8	2 3/4	7/16	1.7
1 3/16	VF2S-219	VS-219	19487	141.3	116.7	79.4	27.4	13.5	39.7	38.1	40.5	15.9	69.9		.77
1 1/4	VF2S-220S	VS-220S													
1 1/4	VF2S-220	VS-220	5782	6 1/8	5 1/8	3 5/8	1 5/32	19/32	1 3/4	1 11/16	1 55/64	11/16	3 3/16	1/2	2.7
1 3/8	VF2S-222	VS-222	25718	155.6	130.2	92.1	29.4	15.1	44.5	42.9	47.2	17.5	81.0		1.22
1 7/16	VF2S-223	VS-223													
1 1/2	VF2S-224	VS-224	7340 32648	6 3/4 171.5	5 21/32 143.7	4 1/8 104.8	1 19/64 32.9	5/8 15.9	2 1/64 51.2	1 15/16 49.2	2 1/16 52.4	3/4 19.1	3 1/2 88.9	1/2	3.6 1.63
1 5/8	VF2S-226	VS-226	7901	7 1/16	5 27/32	4 3/8	1 21/64	5/8	2 3/64	1 15/16	2 19/64	3/4	3 3/4		9/16
1 11/16	VF2S-227	VS-227	35144	179.4	148.4	111.1	33.7	15.9	52.0	49.2	58.3	19.1	95.3	1.68	
1 3/4	VF2S-228	VS-228													
1 15/16	VF2S-231	VS-231	7889	7 7/16	6 3/16	4 9/16	1 23/64	5/8	2 5/32	2 1/32	2 15/32	3/4	4	9/16	4.6
2	VF2S-232S	VS-232S	35090	188.9	157.2	115.9	34.5	15.9	54.8	51.6	62.7	19.1	101.6		2.09
2	VF2S-232	VS-232	9752	8 1/2	7 1/4	5 1/4	1 33/64	13/16	2 5/16	2 3/16	2 23/32	7/8	4 1/4	5/8	5.9
2 3/16	VF2S-235	VS-235	43377	215.9	184.2	133.4	38.5	20.6	58.7	55.6	69.1	22.2	108.0		2.68
2 1/4	VF2S-236	VS-236	11789	9 1/4	7 15/16	5 7/16	1 11/16	13/16	2 11/16	2 9/16	2 63/64	1	4 3/4	5/8	9.6
2 7/16	VF2S-239	VS-239	52437	235.0	201.6	138.1	42.9	20.6	68.3	65.1	75.8	25.4	120.7		4.35

Metric dimensions for reference only.

Not all parts are available from stock. Please contact customer service for availability (800) 626-2120.

For more information on bearing capabilities outside of our standard offering, please contact Application Engineering (800) 626-2093.

Mounted Ball Bearings *Browning*



- Duty:** Standard
- Rolling Elements:** Ball
- Housing:** Cast Iron Two Bolt Flange
- Self Alignment:** +/- 1.5 Degrees
- Lock:** Setscrew
- Seal:** Contact and Flinger
- Temperature:** -20° to 200°F

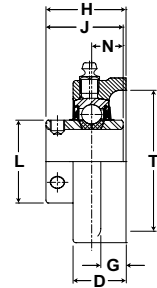
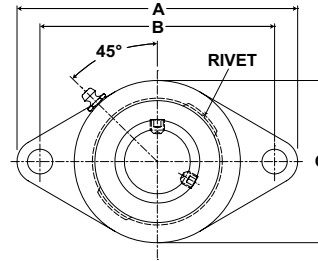

VF2S 200 Series Standard Duty Two Bolt Flanges - Setscrew Locking - Metric

Bore Diameter mm	Part No.	Bearing Insert No.	Basic Dynamic Rating N/lb	Dimensions mm / inch										Bolt Size	Unit Wt. kg/lb
				A	B	C	D	G	H	J	L	N	T Cored		
20	VF2S-20MM	VS-20MM	11614 2611	111.9 4 13/32	90.0 3 17/32	63.5 2 1/2	22.6 57/64	11.1 7/16	32.5 1 9/32	31.0 1 7/32	30.2 1 3/16	12.7 1/2	50.8 2	M10	.45 1.0
25	VF2S-25MM	VS-25MM	12459 2801	123.8 4 7/8	99.0 3 79/88	69.9 2 3/4	24.2 61/64	12.7 1/2	36.5 1 7/16	34.9 1 3/8	34.9 1 3/8	14.3 9/16	58.7 2 5/16	M10	.50 1.1
30	VF2S-30MM	VS-30MM	19487 4381	141.3 5 9/16	116.5 4 44/75	79.4 3 1/8	27.4 1 5/64	13.5 17/32	39.7 1 9/16	38.1 1 1/2	40.5 1 19/32	15.9 5/8	69.9 2 3/4	M10	.77 1.7
35	VF2S-35MM	VS-35MM	25718 5782	155.6 6 1/8	130.0 5 11/93	92.1 3 5/8	29.4 1 5/32	15.1 19/32	44.5 1 3/4	42.9 1 11/16	47.2 1 55/64	17.5 11/16	81.0 3.1875	M12	1.22 2.7
40	VF2S-40MM	VS-40MM	32648 7340	171.5 6 3/4	143.5 5 63/97	104.8 4 1/8	32.9 1 19/64	15.9 5/8	51.2 2 1/64	49.2 1 15/16	52.4 2 1/16	19.1 3/4	88.9 3 1/2	M12	1.63 3.6
45	VF2S-45MM	VS-45MM	35144 7901	179.4 7 1/16	148.5 5 11/13	111.1 4 3/8	33.7 1 21/64	15.9 5/8	52.0 2 3/64	49.2 1 15/16	57.2 2 1/4	19.1 3/4	95.3 3 3/4	M14	1.68 3.7
50	VF2S-50MM	VS-50MM	35090 7889	188.9 7 7/16	157.0 6 17/94	115.9 4 9/16	34.5 1 23/64	15.9 5/8	54.8 2 5/32	51.6 2 1/32	62.7 2 15/32	19.1 3/4	101.6 4	M16	2.09 4.6
55	VF2S-55MM	VS-55MM	43377 9752	215.9 8 1/2	184.0 7 21/86	133.4 5 1/4	38.5 1 33/64	20.6 13/16	58.7 2 5/16	55.6 2 3/16	69.1 2 23/32	22.2 7/8	108.0 4 1/4	M16	2.68 5.9
60	VF2S-60MM	VS-60MM	52437 11789	235.0 9 1/4	202.0 7 81/85	138.1 5 7/16	42.9 1 11/16	20.6 13/16	68.3 2 11/16	65.1 2 9/16	75.8 2 63/64	25.4 1	120.7 4.75	M16	4.35 9.6

Browning®

Mounted Ball Bearings



- Duty:** Standard
- Rolling Elements:** Ball
- Housing:** Cast Iron Two Bolt Flange
- Self Alignment:** +/- 1.5 Degrees
- Lock:** BOA Concentric
- Seal:** Contact and Flinger
- Temperature:** -20° to 200°F

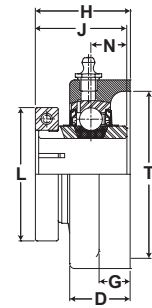
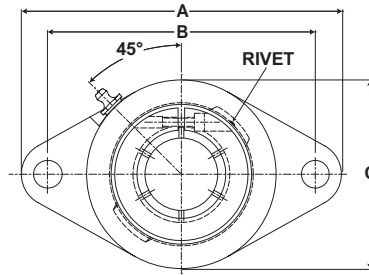

VF2B 200 Series Standard Duty Two Bolt Flanges - BOA Concentric Locking

Bore Diameter inch	Part No.	Bearing Insert No.	Basic Dynamic Rating lb/N	Dimensions inch / mm										Bolt Size	Unit Wt. lb/kg
				A	B	C	D	G	H	J	L	N	T Cored		
3/4	VF2B-212	VB-212	2611 11614	4 13/32 111.9	3 17/32 89.7	2 1/2 63.5	57/64 22.6	7/16 11.1	1 11/32 34.1	1 9/32 32.5	1 3/4 44.5	1/2 12.7	2 50.8	3/8	1.1 .50
7/8	VF2B-214	VB-214	2801 12459	4 7/8 123.8	3 57/64 98.8	2 3/4 69.9	61/64 24.2	1/2 12.7	1 1/2 38.1	1 7/16 36.5	1 15/16 49.2	9/16 14.3	2 5/16 58.7	7/16	1.3 .59
15/16	VF2B-215	VB-215													
1	VF2B-216	VB-216													
1 1/8	VF2B-218	VB-218	4381 19487	5 9/16 141.3	4 19/32 116.7	3 1/8 79.4	1 5/64 27.4	17/32 13.5	1 5/8 41.3	1 9/16 39.7	2 3/16 55.6	5/8 15.9	2 3/4 69.9	7/16	2.0 .91
1 3/16	VF2B-219	VB-219													
1 1/4	VF2B-220S	VB-220S													
1 1/4	VF2B-220	VB-220	5782 25718	6 1/8 155.6	5 1/8 130.2	3 5/8 92.1	1 5/32 29.4	19/32 15.1	1 13/16 46.0	1 3/4 44.5	2 7/16 61.9	11/16 17.5	3 3/16 81.0	1/2	3.0 1.36
1 3/8	VF2B-222	VB-222	5782 25718	6 1/8 155.6	5 1/8 130.2	3 5/8 92.1	1 5/32 29.4	19/32 15.1	1 13/16 46.0	1 3/4 44.5	2 9/16 65.1	11/16 17.5	3 3/16 81.0	1/2	3.0 1.36
1 7/16	VF2B-223	VB-223													
1 1/2	VF2B-224	VB-224	7340 32648	6 3/4 171.5	5 21/32 143.7	4 1/8 104.8	1 19/64 32.9	5/8 15.9	2 5/64 52.8	2 50.8	2 11/16 68.3	3/4 19.1	3 1/2 88.9	1/2	3.3 1.50
1 5/8	VF2B-226	VB-226	7901 35144	7 1/16 179.4	5 27/32 148.4	4 3/8 111.1	1 21/64 33.7	5/8 15.9	2 7/64 53.6	2 50.8	2 13/16 71.4	3/4 19.1	3 3/4 95.3	9/16	4.0 1.81
1 11/16	VF2B-227	VB-227	7901 35144	7 1/16 179.4	5 27/32 148.4	4 3/8 111.1	1 21/64 33.7	5/8 15.9	2 7/64 53.6	2 50.8	2 15/16 74.6	3/4 19.1	3 3/4 95.3	9/16	4.0 1.81
1 3/4	VF2B-228	VB-228													
1 15/16	VF2B-231	VB-231	7889 35090	7 7/16 188.9	6 3/16 157.2	4 9/16 115.9	1 23/64 34.5	5/8 15.9	2 7/32 56.4	2 3/32 53.2	3 3/8 85.7	3/4 19.1	4 101.6	9/16	4.2 1.91
2	VF2B-232S	VB-232S													
2	VF2B-232	VB-232	9752 43377	8 1/2 215.9	7 1/4 184.2	5 1/4 133.4	1 33/64 38.5	13/16 20.6	2 3/8 60.3	2 1/4 57.2	3 1/2 88.9	7/8 22.2	4 1/4 108.0	5/8	7.1 3.22
2 3/16	VF2B-235	VB-235	9752 43377	8 1/2 215.9	7 1/4 184.2	5 1/4 133.4	1 33/64 38.5	13/16 20.6	2 3/8 60.3	2 1/4 57.2	3 5/8 92.1	7/8 22.2	4 1/4 108.0	5/8	7.1 3.22

Metric dimensions for reference only.

Not all parts are available from stock. Please contact customer service for availability (800) 626-2120.

For more information on bearing capabilities outside of our standard offering, please contact Application Engineering (800) 626-2093.

Mounted Ball Bearings *Browning*



- Duty:** Standard
- Rolling Elements:** Ball
- Housing:** Cast Iron Two Bolt Flange
- Self Alignment:** +/- 1.5 Degrees
- Lock:** Eccentric
- Seal:** Contact and Flinger
- Temperature:** -20° to 200°F

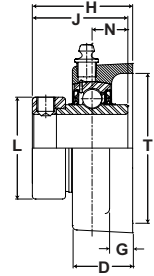
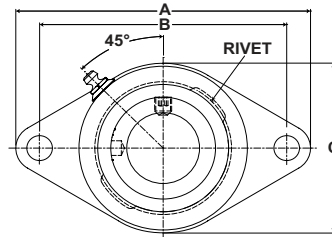

VF2E 200 Series Standard Duty Two Bolt Flanges - Eccentric Locking

Bore Diameter inch	Part No.	Bearing Insert No.	Basic Dynamic Rating lb/N	Dimensions inch / mm										Bolt Size	Unit Wt. lb/kg
				A	B	C	D	G	H	J	L	N	T Cored		
1/2	VF2E-208	VE-208	2108	3 7/8	3	2 1/8	1 1/32	1/2	1 43/64	1 15/32	1 3/16	35/64	1 3/4	3/8	1.0
5/8	VF2E-210	VE-210	9377	98.4	76.2	54.0	26.2	12.7	42.5	37.3	30.2	13.9	44.5		.45
3/4	VF2E-212	VE-212	2611 11614	4 13/32	3 17/32	2 1/2	1 5/64	1/2	1 51/64	1 23/32	1 5/16	43/64	2	3/8	1.1 .50
7/8	VF2E-214	VE-214	2801	4 7/8	3 57/64	2 3/4	1 5/64	17/32	1 13/16	1 3/4	1 1/2	11/16	2 5/16		7/16
15/16	VF2E-215	VE-215	12459	123.8	98.8	69.9	27.4	13.5	46.0	44.5	38.1	17.5	58.7	7/16	
1	VF2E-216	VE-216	4381 19487	5 9/16	4 19/32	3 1/8	1 13/64	17/32	2	1 29/32	1 3/4	23/32	2 3/4		7/16
1 1/8	VF2E-218	VE-218	5782	6 1/8	5 1/8	3 5/8	1 1/4	5/8	2 1/8	2 1/64	2 3/16	3/4	3 3/16	1/2	
1 3/16	VF2E-219	VE-219	25718	155.6	130.2	92.1	31.8	15.9	54.0	51.2	55.6	19.1	81.0		1/2
1 1/4	VF2E-220S	VE-220S	7340 32648	6 3/4	5 21/32	4 1/8	1 13/32	5/8	2 5/16	2 7/32	2 3/8	27/32	3 1/2	1/2	
1 1/4	VF2E-220	VE-220	7901	7 1/16	5 27/32	4 3/8	1 13/32	5/8	2 5/16	2 7/32	2 1/2	27/32	3 3/4		9/16
1 11/16	VF2E-227	VE-227	35144	179.4	148.4	111.1	35.7	15.9	58.7	56.4	63.5	21.4	95.3	9/16	
1 3/4	VF2E-228	VE-228	7889 35090	7 7/16	6 3/16	4 9/16	1 39/64	11/16	2 5/8	2 15/32	2 3/4	31/32	4		9/16
1 15/16	VF2E-231	VE-231	9752	8 1/2	7 1/4	5 1/4	1 49/64	13/16	2 31/32	2 13/16	3	1 3/32	4 1/4	5/8	
2	VF2E-232	VE-232	43377	215.9	184.2	133.4	44.8	20.6	75.4	71.4	76.2	27.8	108.0		5/8
2 7/16	VF2E-235	VE-235	11789	9 1/4	7 15/16	5 7/16	1 31/32	13/16	3 1/4	3 1/16	3 3/8	1 7/32	4 3/4	5/8	
2 1/4	VF2E-236	VE-236	52437	235.0	201.6	138.1	50.0	20.6	82.6	77.8	85.7	31.0	120.7		5/8
2 7/16	VF2E-239	VE-239													

Browning®

Mounted Ball Bearings



- Duty:** Medium
- Rolling Elements:** Ball
- Housing:** Cast Iron Two Bolt Flange
- Self Alignment:** +/- 1.5 Degrees
- Lock:** Setscrew
- Seal:** Contact and Flinger
- Temperature:** -20° to 200°F

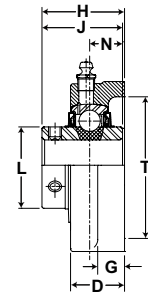
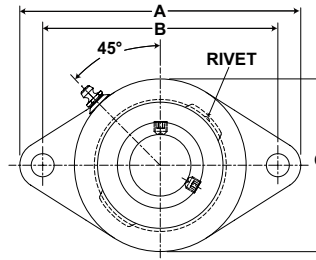

VF2S 300 Series Medium Duty Two Bolt Flanges - Setscrew Locking

Bore Diameter inch	Part No.	Bearing Insert No.	Basic Dynamic Rating lb/N	Dimensions inch / mm										Bolt Size	Unit Wt. lb/kg
				A	B	C	D	G	H	J	L	N	T Cored		
1	VF2S-316	VS-316	4381 19487	5 9/16 141.3	4 19/32 116.7	3 1/8 79.4	1 5/64 27.4	17/32 13.5	1 9/16 39.7	1 1/2 38.1	1 19/32 40.5	5/8 15.9	2 3/4 69.9	7/16	2.7 1.22
1 3/16	VF2S-319	VS-319	5782	6 1/8	5 1/8	3 5/8	1 5/32	19/32	1 3/4	1 11/16	1 55/64	11/16	3 3/16	1/2	2.7 1.22
1 1/4	VF2S-320	VS-220	25718	155.6	130.2	92.1	29.4	15.1	44.5	42.9	47.2	17.5	81.0		
1 7/16	VF2S-323	VS-323	7340 32648	6 3/4 171.5	5 21/32 143.7	4 1/8 104.8	1 19/64 32.9	5/8 15.9	2 1/64 51.2	1 15/16 49.2	2 1/16 52.4	3/4 19.1	3 1/2 88.9	1/2	4.8 2.18
1 1/2	VF2S-324	VS-324	7901 35144	7 1/16 179.4	5 27/32 148.4	4 3/8 111.1	1 21/64 33.7	5/8 15.9	2 3/64 52.0	1 15/16 49.2	2 19/64 58.3	3/4 19.1	3 3/4 95.3	9/16	4.8 2.18
1 11/16	VF2S-327	VS-327	7889	7 7/16	6 3/16	4 9/16	1 23/64	5/8	2 5/32	2 1/32	2 15/32	3/4	4	9/16	7.6 3.45
1 3/4	VF2S-328	VS-328	35090	188.9	157.2	115.9	34.5	15.9	54.8	51.6	62.7	19.1	101.6		
1 15/16	VF2S-331	VS-331	9752	8 1/2	7 1/4	5 1/4	1 33/64	13/16	2 5/16	2 3/16	2 23/32	7/8	4 1/4	5/8	9.6 4.35
2	VF2S-332	VS-232S	43377	215.9	184.2	133.4	38.5	20.6	58.7	55.6	69.1	22.2	108.0		

Metric dimensions for reference only.

Not all parts are available from stock. Please contact customer service for availability (800) 626-2120.

For more information on bearing capabilities outside of our standard offering, please contact Application Engineering (800) 626-2093.

Mounted Ball Bearings *Browning*



- Duty:** Medium
- Rolling Elements:** Ball
- Housing:** Cast Iron Two Bolt Flange
- Self Alignment:** +/- 1.5 Degrees
- Lock:** BOA Concentric
- Seal:** Contact and Flinger
- Temperature:** -20° to 200°F

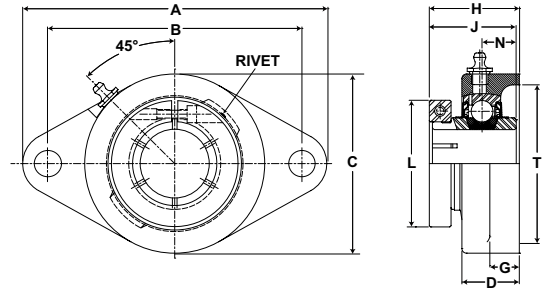

VF2B 300 Series Medium Duty Two Bolt Flanges - BOA Concentric Locking

Bore Diameter inch	Part No.	Bearing Insert No.	Basic Dynamic Rating lb/N	Dimensions inch / mm										Bolt Size	Unit Wt. lb/kg
				A	B	C	D	G	H	J	L	N	T Cored		
1	VF2B-316	VB-316	4381	5 9/16	4 19/32	3 1/8	1 5/64	17/32	1 5/8	1 9/16	2 1/16	5/8	2 3/4	7/16	2.0 .91
			19487	141.3	116.7	79.4	27.4	13.5	41.3	39.7	2.1	15.9	69.9		
1 3/16	VF2B-319	VB-319	5782	6 1/8	5 1/8	3 5/8	1 5/32	19/32	1 13/16	1 3/4	2 7/16	11/16	3 3/16	1/2	3.0 1.36
1 1/4	VF2B-320	VB-220	25718	155.6	130.2	92.1	29.4	15.1	46.0	44.5	61.9	17.5	81.0		
1 7/16	VF2B-323	VB-323	7340	6 3/4	5 21/32	4 1/8	1 19/64	5/8	2 5/64	2	2 11/16	3/4	3 1/2	1/2	3.3 1.50
			32648	171.5	143.7	104.8	32.9	15.9	52.8	50.8	68.3	19.1	88.9		
1 1/2	VF2B-324	VB-324	7901	7 1/16	5 27/32	4 3/8	1 21/64	5/8	2 7/64	2	2 13/16	3/4	3 3/4	9/16	4.0 1.81
			35144	179.4	148.4	111.1	33.7	15.9	53.6	50.8	71.4	19.1	95.3		
1 11/16	VF2B-327	VB-327	7889	7 7/16	6 3/16	4 9/16	1 23/64	5/8	2 7/32	2 3/32	3 1/4	3/4	4	9/16	5.2 2.36
1 3/4	VF2B-328	VB-328	35090	188.9	157.2	115.9	34.5	15.9	56.4	53.2	82.6	19.1	101.6		
1 15/16	VF2B-331	VB-331	9752	8 1/2	7 1/4	5 1/4	1 33/64	13/16	2 3/8	2 1/4	3 1/2	7/8	4 1/4	5/8	7.1 3.22
			43377	215.9	184.2	133.4	38.5	20.6	60.3	57.2	88.9	22.2	108.0		
2	VF2B-332	VB-232S													

Browning[®] Mounted Ball Bearings



- Duty:** Standard
- Rolling Elements:** Ball
- Housing:** Cast Iron Flange Bracket
- Self Alignment:** +/- 1.5 Degrees
- Lock:** Setscrew
- Seal:** Contact and Flinger
- Temperature:** -20° to 200°F

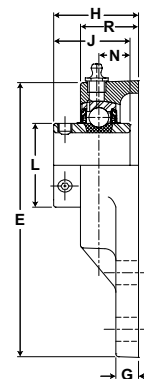
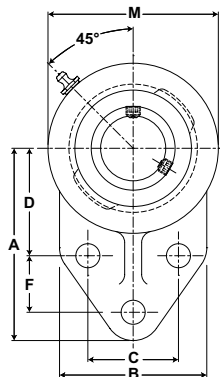

VFBS 200 Series Standard Duty Flange Brackets - Setscrew Locking

Bore Diameter inch	Part No.	Bearing Insert No.	Basic Dynamic Rating lb/N	Dimensions inch / mm													Bolt Size	Unit Wt. lb/kg
				A	B	C	D	E	F	G	H	J	L	M	N	R		
3/4	VFBS-212	VS-212	2611 11614	3 76.2	2 3/8 60.3	1 1/2 38.1	1 11/16 42.9	4 3/16 106.4	7/8 22.2	5/16 7.9	1 11/32 34.1	1 7/32 26.2	1 3/16 30.2	2 3/8 60.3	1/2 12.7	61/64 24.2	3/8	1.1 .50
7/8	VFBS-214	VS-214	2801 12459	3 3/8 85.7	2 1/2 63.5	1 5/8 41.3	1 13/16 46.0	4 3/4 120.7	1 1/8 28.6	3/8 9.5	1 1/2 38.1	1 3/8 34.9	1 3/8 34.9	2 3/4 69.9	9/16 14.3	1 1/64 25.8	3/8	1.9 .86
15/16	VFBS-215	VS-215																
1	VFBS-216	VS-216																
1 1/8	VFBS-218	VS-218	4381 19487	3 3/4 95.3	2 3/4 69.9	1 7/8 47.6	2 1/16 52.4	5 23/64 136.1	1 1/4 31.8	3/8 9.5	1 5/8 41.3	1 1/2 38.1	1 19/32 40.5	3 7/32 81.8	5/8 15.9	1 9/64 29.0	3/8	2.8 1.27
1 3/16	VFBS-219	VS-219																
1 1/4	VFBS-220S	VS-220S																
1 1/4	VFBS-220	VS-220	5782 25718	4 1/4 108.0	3 1/4 82.6	2 50.8	2 3/8 60.3	6 1/8 155.6	1 1/4 31.8	1/2 12.7	1 7/8 47.6	1 11/16 42.9	1 55/64 47.2	3 3/4 95.3	11/16 17.5	1 9/32 32.5	1/2	2.6 1.18
1 3/8	VFBS-222	VS-222																
1 7/16	VFBS-223	VS-223																
1 15/16	VFBS-231	VS-231	7889 35090	5 3/16 131.8	4 101.6	2 3/4 69.9	2 15/16 74.6	7 15/32 189.7	1 5/8 41.3	1/2 12.7	2 5/32 54.8	2 1/32 51.6	2 15/32 62.7	4 9/16 115.9	3/4 19.1	1 23/64 34.5	1/2	4.2 1.91
2	VFBS-232S	VS-232S																

Metric dimensions for reference only.

Not all parts are available from stock. Please contact customer service for availability (800) 626-2120.

For more information on bearing capabilities outside of our standard offering, please contact Application Engineering (800) 626-2093.

Mounted Ball Bearings *Browning*



- Duty:** Standard
- Rolling Elements:** Ball
- Housing:** Cast Iron Flange Bracket
- Self Alignment:** +/- 1.5 Degrees
- Lock:** BOA Concentric
- Seal:** Contact and Flinger
- Temperature:** -20° to 200°F

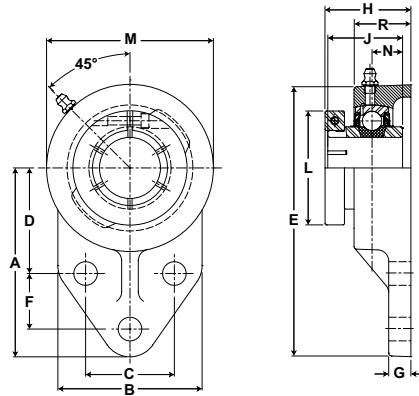

VFBB 200 Series Standard Duty Flange Brackets - BOA Concentric Locking

Bore Diameter inch	Part No.	Bearing Insert No.	Basic Dynamic Rating lb/N	Dimensions inch / mm													Bolt Size	Unit Wt. lb/kg
				A	B	C	D	E	F	G	H	J	L	M	N	R		
3/4	VFBB-212	VB-212	2611 11614	3 76.2	2 3/8 60.3	1 1/2 38.1	1 11/16 42.9	4 3/16 106.4	7/8 22.2	5/16 7.9	1 13/32 35.7	1 9/32 32.5	1 3/4 44.5	2 3/8 60.3	1/2 12.7	61/64 24.2	3/8	1.2 .54
7/8	VFBB-214	VB-214	2801 12459	3 3/8 85.7	2 1/2 63.5	1 5/8 41.3	1 13/16 46.0	4 3/4 120.7	1 1/8 28.6	3/8 9.5	1 9/16 39.7	1 7/16 36.5	1 15/16 49.2	2 3/4 69.9	9/16 14.3	1 1/64 25.8	3/8	2.1 .95
15/16	VFBB-215	VB-215																
1	VFBB-216	VB-216																
1 1/8	VFBB-218	VB-218	4381 19487	3 3/4 95.3	2 3/4 69.9	1 7/8 47.6	2 1/16 52.4	5 23/64 136.1	1 1/4 31.8	3/8 9.5	1 11/16 42.9	1 9/16 39.7	2 3/16 55.6	3 7/32 81.8	5/8 15.9	1 9/64 29.0	3/8	2.8 1.27
1 3/16	VFBB-219	VB-219																
1 1/4	VFBB-220S	VB-220S																
1 1/4	VFBB-220	VB-220	4381 19487	4 1/4 108.0	3 1/4 82.6	2 50.8	2 3/8 60.3	6 1/8 155.6	1 1/4 31.8	1/2 12.7	1 15/16 49.2	1 3/4 44.5	2 7/16 61.9	3 3/4 95.3	11/16 17.5	1 9/32 32.5	3/8	2.9 1.32
1 3/8	VFBB-222	VB-222	5782	4 1/4 108.0	3 1/4 82.6	2 50.8	2 3/8 60.3	6 1/8 155.6	1 1/4 31.8	1/2 12.7	1 15/16 49.2	1 3/4 44.5	2 9/16 65.1	3 3/4 95.3	11/16 17.5	1 9/32 32.5	1/2	2.9 1.32
1 7/16	VFBB-223	VB-223	25718															
1 15/16	VFBB-231	VB-231	7889	5 3/16 131.8	4 101.6	2 3/4 69.9	2 15/16 74.6	7 15/32 189.7	1 5/8 41.3	1/2 12.7	2 7/32 56.4	2 3/32 52.2	3 3/8 85.7	4 9/16 115.9	3/4 19.1	1 23/64 34.5	1/2	4.8 2.18
2	VFBB-232S	VB-232S	35090															

Browning[®] Mounted Ball Bearings



- Duty:** Standard
- Rolling Elements:** Ball
- Housing:** Cast Iron Piloted Flange Cartridge
- Self Alignment:** +/- 1.5 Degrees
- Lock:** Setscrew
- Seal:** Contact and Flinger
- Temperature:** -20° to 200°F

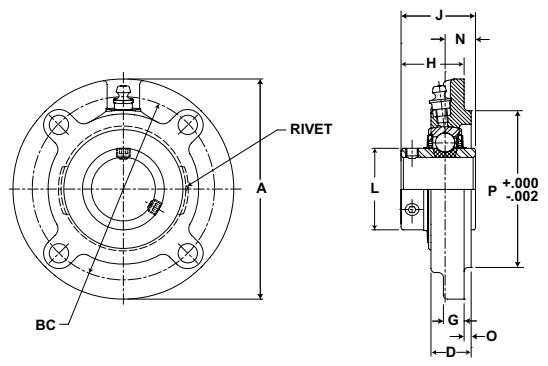

VFCS 200 Series Standard Duty Piloted Flange Cartridges - Setscrew Locking

Bore Diameter inch	Part No.	Bearing Insert No.	Basic Dynamic Rating lb/N	Dimensions inch / mm										Bolt Size	Unit Wt. lb/kg
				A	BC	D	G	H	J	L	N	O	P		
1 1/8	VFCS-218	VS-218	4381 19487	4 3/8	3 5/8	1 63/64	13/32	1 1/4	1 1/2	1 19/32	5/8	7/32	3.000	5/16	2.4 1.09
1 3/16	VFCS-219	VS-219		111.1	92.1	50.4	10.3	31.8	38.1	40.5	15.9	5.6	76.20		
1 1/4	VFCS-220S	VS-220S													
1 1/4	VFCS-220	VS-220	5782 25718	5	4 1/8	1 1/16	13/32	1 5/16	1 11/16	1 55/64	11/16	11/32	3.375	3/8	3.2 1.45
1 3/8	VFCS-222	VS-222		127.0	104.8	27.0	10.3	33.3	42.9	47.2	17.5	8.7	85.73		
1 7/16	VFCS-223	VS-223													
1 1/2	VFCS-224	VS-224	7340 32648	5 1/4	4 3/8	1 3/16	13/32	1 1/2	1 15/16	2 1/16	3/4	13/32	3.625	3/8	3.6 1.63
1 5/8	VFCS-226	VS-226													
1 11/16	VFCS-227	VS-227	7901 35144	6 1/8	5 1/8	1 3/16	13/32	1 1/2	1 15/16	2 19/64	3/4	13/32	4.250		
1 3/4	VFCS-228	VS-228		155.6	130.2	30.2	10.3	38.1	49.2	58.3	19.1	10.3	107.95	7/16	4.9 2.22
1 15/16	VFCS-231	VS-231	7889 35090	6 1/8	5 1/8	1 15/64	13/32	1 19/32	2 1/16	2 15/32	3/4	7/16	4.250	7/16	5.7 2.59
2	VFCS-232S	VS-232S		155.6	130.2	31.4	10.3	40.5	52.4	62.7	19.1	11.1	107.95		
2	VFCS-232	VS-232	9752	6 3/8	5 3/8	1 3/8	13/32	1 37/64	2 13/64	2 23/32	7/8	19/32	4.500	7/16	6.0 2.72
2 3/16	VFCS-235	VS-235	43377	161.9	136.5	34.9	10.3	40.1	56.0	69.1	22.2	15.1	114.30		
2 1/4	VFCS-236	VS-236	11789	7 1/8	6	1 27/32	17/32	2	2 7/8	2 63/64	1	23/32	5.000	1/2	7.1 3.22
2 7/16	VFCS-239	VS-239	52437	181.0	152.4	46.8	13.5	50.8	73.0	75.8	25.4	18.3	127.00		

Metric dimensions for reference only.
 Not all parts are available from stock. Please contact customer service for availability (800) 626-2120.
 For more information on bearing capabilities outside of our standard offering, please contact Application Engineering (800) 626-2093.

Mounted Ball Bearings *Browning*



- Duty:** Standard
- Rolling Elements:** Ball
- Housing:** Cast Iron Piloted Flange Cartridge
- Self Alignment:** +/- 1.5 Degrees
- Lock:** BOA Concentric
- Seal:** Contact and Flinger
- Temperature:** -20° to 200°F

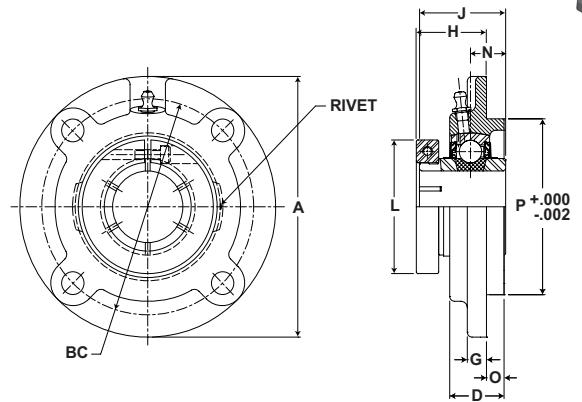

VFCB 200 Series Standard Duty Piloted Flange Cartridges - BOA Concentric Locking

Bore Diameter inch	Part No.	Bearing Insert No.	Basic Dynamic Rating lb/N	Dimensions inch / mm										Bolt Size	Unit Wt. lb/kg
				A	BC	D	G	H	J	L	N	O	P		
1 1/8	VFCB-218	VB-218	4381	4 3/8	3 5/8	63/64	13/32	1 5/16	1 9/16	2 3/16	5/8	7/32	3.000	3/8	2.6
1 3/16	VFCB-219	VB-219	19487	111.1	92.1	25.0	10.3	33.3	39.7	55.6	15.9	5.6	76.20		1.18
1 1/4	VFCB-220	VB-220	5782 25718	5 127.0	4 1/8	1 1/16	13/32	1 3/8	1 3/4	2 7/16	11/16	11/32	3.375 85.73	3/8	3.5 1.59
1 3/8	VFCB-222	VB-222	5782	5	4 1/8	1 1/16	13/32	1 3/8	1 3/4	2 9/16	11/16	11/32	3.375		3.5
1 7/16	VFCB-223	VB-223	25718	127.0	104.8	27.0	10.3	34.9	44.5	65.1	17.5	8.7	85.73	3/8	1.59
1 1/2	VFCB-224	VB-224	7340 32648	5 1/4 133.4	4 3/8	1 3/16	13/32	1 9/16	2	2 11/16	3/4	13/32	3.625 92.08	3/8	3.9 1.77
1 5/8	VFCB-226	VB-226	7901 35144	6 1/8 155.6	5 1/8	1 3/16	13/32	1 9/16	2	2 13/16	3/4	13/32	4.250 107.95		7/16
1 11/16	VFCB-227	VB-227	7901	6 1/8	5 1/8	1 3/16	13/32	1 9/16	2	2 15/16	3/4	13/32	4.250	7/16	5.2
1 3/4	VFCB-228	VB-228	35144	155.6	130.2	30.2	10.3	39.7	50.8	74.6	19.1	10.3	107.95		2.36
1 15/16	VFCB-231	VB-231	7889	6 1/8	5 1/8	1 15/64	13/32	1 21/32	2 3/32	3 3/8	3/4	7/16	4.250	7/16	6.3
2	VFCB-232S	VB-232S	35090	155.6	130.2	31.4	10.3	42.1	53.2	85.7	19.1	11.1	107.95		2.86
2	VFCB-232	VB-232	9752 43377	6 3/8 161.9	5 3/8	1 3/8	13/32	1 41/64	2 1/4	3 1/2	7/8	19/32	4.500 114.30	7/16	6.6 2.99
2 3/16	VFCB-235	VB-235	9752	161.9	136.5	34.9	10.3	41.7	57.2	88.9	22.2	15.1	114.30		6.6
2 1/4	VFCB-236	VB-236	11789 52437	7 1/8 181.0	6	1 27/32	17/32	2 1/16	2 5/8	4 1/16	1	23/32	5.000 127.00	1/2	8.3 3.76
2 7/16	VFCB-239	VB-239	11789	181.0	152.4	46.8	13.5	52.4	66.7	104.8	25.4	18.3	127.00		8.3

Browning[®] Mounted Ball Bearings



- Duty:** Medium
- Rolling Elements:** Ball
- Housing:** Cast Iron Piloted Flange Cartridge
- Self Alignment:** +/- 1.5 Degrees
- Lock:** Setscrew
- Seal:** Contact and Flinger
- Temperature:** -20° to 200°F

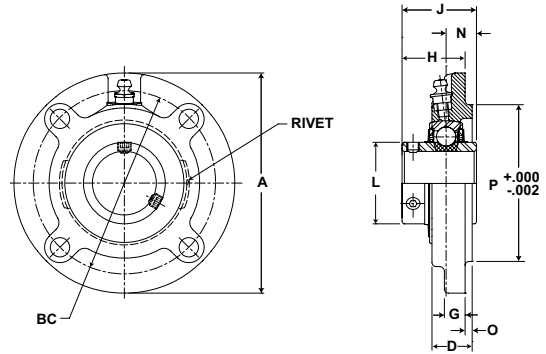

VFCS 300 Series Medium Duty Piloted Flange Cartridges - Setscrew Locking

Bore Diameter inch	Part No.	Bearing Insert No.	Basic Dynamic Rating lb/N	Dimensions inch / mm										Bolt Size	Unit Wt. lb/kg
				A	BC	D	G	H	J	L	N	O	P		
1	VFCS-316	VS-316	4381 19487	4 3/8 111.1	3 5/8 92.1	63/64 25.0	13/32 10.3	1 1/4 31.8	1 1/2 38.1	1 19/32 40.5	5/8 15.9	7/32 5.6	3.000 76.20	5/16	2.5 1.13
1 3/16	VFCS-319	VS-319	5782	5 127.0	4 1/8 104.8	1 1/16 27.0	13/32 10.3	1 5/16 33.3	1 11/16 42.9	1 55/64 47.2	11/16 17.5	11/32 8.7	3.375 85.73	3/8	3.2 1.45
1 1/4	VFCS-320	VS-220	25718												
1 7/16	VFCS-323	VS-323	7340 32648	5 1/4 133.4	4 3/8 111.1	1 3/16 30.2	13/32 10.3	1 1/2 38.1	1 15/16 49.2	2 1/16 52.4	3/4 19.1	13/32 10.3	3.625 92.08	3/8	3.7 1.68
1 1/2	VFCS-324	VS-324	7901 35144	6 1/8 155.6	5 1/8 130.2	1 3/16 30.2	13/32 10.3	1 1/2 38.1	1 15/16 49.2	2 19/64 58.3	3/4 19.1	13/32 10.3	4.250 107.95	7/16	5.0 2.27
1 11/16	VFCS-327	VS-327	7889	6 1/8 155.6	5 1/8 130.2	1 15/64 31.4	13/32 10.3	1 19/32 40.5	2 1/32 51.6	2 15/32 62.7	3/4 19.1	7/16 11.1	4.250 107.95	7/16	5.8 2.63
1 3/4	VFCS-328	VS-328	35090												
1 15/16	VFCS-331	VS-331	9752	6 3/8 161.9	5 3/8 136.5	1 3/8 34.9	13/32 10.3	1 37/64 40.1	2 3/16 55.6	2 23/32 69.1	7/8 22.2	19/32 15.1	4.500 114.30	7/16	6.0 2.72
2	VFCS-332	VS-232	43377												
2 3/16	VFCS-335	VS-335	11789	7 1/8 181.0	6 152.4	1 27/32 46.8	17/32 13.5	2 50.8	2 7/16 61.9	2 63/64 75.8	1 25.4	27/32 21.4	5.000 127.00	1/2	6.1 2.77
2 1/4	VFCS-336	VS-236	52437												

Metric dimensions for reference only.

Mounted Ball Bearings *Browning*



- Duty:** Medium
- Rolling Elements:** Ball
- Housing:** Cast Iron Piloted Flange Cartridge
- Self Alignment:** +/- 1.5 Degrees
- Lock:** BOA Concentric
- Seal:** Contact and Flinger
- Temperature:** -20° to 200°F

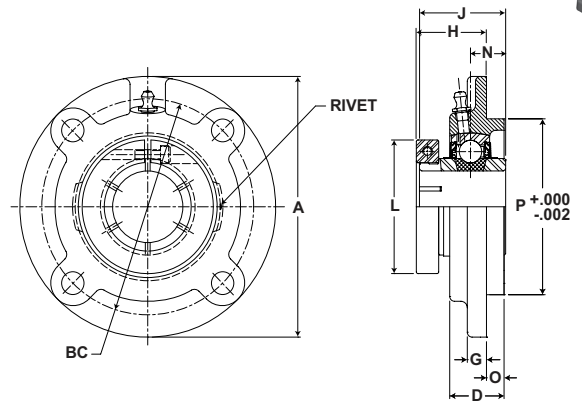

VFCB 300 Series Medium Duty Piloted Flange Cartridges - BOA Concentric Locking

Bore Diameter inch	Part No.	Bearing Insert No.	Basic Dynamic Rating lb/N	Dimensions inch / mm										Bolt Size	Unit Wt. lb/kg
				A	BC	D	G	H	J	L	N	O	P		
1	VFCB-316	VB-316	4381	4 3/8	3 5/8	63/64	13/32	1 5/16	1 9/16	2 1/16	5/8	7/32	3.000	3/16	2.7
			19487	111.1	92.1	25.0	10.3	33.3	39.7	52.4	15.9	5.6	76.20		1.22
1 3/16	VFCB-319	VB-319	5782	5	4 1/8	1 1/16	13/32	1 3/8	1 3/4	2 7/16	11/16	11/32	3.375	3/8	3.7
1 1/4	VFCB-320	VB-220	25718												
1 7/16	VFCB-323	VB-323	7340	5 1/4	4 3/8	1 3/16	13/32	1 9/16	2	2 11/16	3/4	13/32	3.625	3/8	4.2
			32648												
1 1/2	VFCB-324	VB-324	7901	6 1/8	5 1/8	1 3/16	13/32	1 9/16	2	2 13/16	3/4	13/32	4.250	7/16	5.8
			35144												
1 11/16	VFCB-327	VB-327	7889	6 1/8	5 1/8	1 15/64	13/32	1 23/32	2 3/32	3 1/4	3/4	7/16	4.250	7/16	6.8
1 3/4	VFCB-328	VB-328	35090												
1 15/16	VFCB-331	VB-331	9752	6 3/8	5 3/8	1 3/8	13/32	1 51/64	2 1/4	3 1/2	7/8	19/32	4.500	7/16	7.1
2	VFCB-332	VB-232	43377												
2 3/16	VFCB-335	VB-335	11789	7 1/8	6	1 27/32	13/32	2 1/16	2 5/8	4 1/16	1 9/32	27/32	5.000	1/2	7.7
			52437												

Browning[®] Mounted Ball Bearings



Duty: Intermediate
Rolling Elements: Ball
Housing: Cast Iron Wide Slot Take Up
Self Alignment: +/- 1.5 Degrees
Lock: Setscrew
Seal: Contact
Temperature: -20° to 200°F

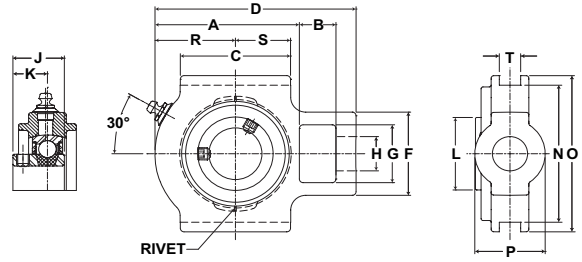

VTWS 100 Series Intermediate Duty Wide Slot Take Ups - Setscrew Locking

Bore Diameter inch	Part No.	Bearing Insert No.	Basic Dynamic Rating lb/N	Dimensions inch / mm														Unit Wt. lb/kg		
				A	B	C	D	F	G	H Core	J	K	L	N	O	P Hub	R		S	T
3/4	VTWS-112	VS-112	2611 11614	3 76.2	5/8 15.9	2 1/4 57.2	4 101.6	1 7/8 47.6	1 1/4 31.8	3/4 19.1	1 1/16 27.0	23/32 18.3	1 3/16 30.2	3 76.2	3 1/2 88.9	1 3/8 34.9	1 7/16 36.5	1 1/8 28.6	17/32 13.5	1.6 .73
7/8	VTWS-114	VS-114	2801	3 5/64 78.2	5/8 15.9	2 1/4 57.2	4 3/32 104.0	1 7/8 47.6	1 1/4 31.8	3/4 19.1	1 7/64 28.2	49/64 19.4	1 3/8 34.9	3 76.2	3 1/2 88.9	1 1/2 38.1	1 9/16 39.7	1 1/8 28.6	17/32 13.5	1.7 .77
15/16	VTWS-115	VS-115	12459																	
1	VTWS-116	VS-116																		
1 1/8	VTWS-118	VS-118	4381	3 3/8 85.7	3/4 19.1	2 1/2 63.5	4 5/8 117.5	2 1/8 54.0	1 7/16 36.5	7/8 22.2	1 5/32 29.4	25/32 19.8	1 19/32 40.5	3 1/2 88.9	4 101.6	1 3/4 44.5	1 25/32 45.2	1 1/4 31.8	17/32 13.5	2.4 1.09
1 3/16	VTWS-119	VS-119	19487																	
1 1/4	VTWS-120S	VS-120S																		
1 1/4	VTWS-120	VS-120	5782	3 3/4 95.3	3/4 19.1	2 3/4 69.9	5 127.0	2 1/8 54.0	1 7/16 36.5	7/8 22.2	1 9/32 32.5	55/64 21.8	1 55/64 47.2	3 1/2 88.9	4 101.6	1 3/4 44.5	2 50.8	1 3/8 34.9	17/32 13.5	3.1 1.41
1 3/8	VTWS-122	VS-122	25718																	
1 7/16	VTWS-123	VS-123																		
1 1/2	VTWS-124	VS-124	7340 32648	4 7/32 107.2	3/4 19.1	3 1/4 82.6	5 19/32 142.1	2 3/4 69.9	1 15/16 49.2	1 1/8 28.6	1 27/64 36.1	15/16 23.8	2 1/16 52.4	4 101.6	4 1/2 114.3	2 1/8 54.0	2 3/16 55.6	1 5/8 41.3	11/16 17.5	4.7 2.13
1 11/16	VTWS-127	VS-127	7901	4 3/8 111.1	3/4 19.1	3 1/4 82.6	5 3/4 146.1	2 3/4 69.9	1 15/16 49.2	1 1/8 28.6	1 7/16 36.5	61/64 24.2	2 19/64 58.3	4 101.6	4 1/2 114.3	2 1/8 54.0	2 1/4 57.2	1 5/8 41.3	11/16 17.5	5.2 2.36
1 3/4	VTWS-128	VS-128	35144																	
1 15/16	VTWS-131	VS-131	7889	4 17/32 115.1	3/4 19.1	3 3/8 85.7	5 29/32 150.0	2 3/4 69.9	1 15/16 49.2	1 1/8 28.6	1 35/64 39.3	1 3/64 26.6	2 15/32 62.7	4 101.6	4 1/2 114.3	2 1/8 54.0	2 5/16 58.7	1 11/16 42.9	11/16 17.5	5.4 2.45
2	VTWS-132S	VS-132S	35090																	
2	VTWS-132	VS-132	9752	5 3/32 129.4	1 25.4	3 3/4 95.3	6 27/32 173.8	3 5/8 92.1	2 1/2 63.5	1 3/8 34.9	1 21/32 42.1	1 7/64 28.2	2 23/32 69.1	5 1/8 130.2	5 3/4 146.1	2 1/2 63.5	2 9/16 65.1	1 7/8 47.6	1 1/16 27.0	8.0 3.63
2 3/16	VTWS-135	VS-135	43377																	

Refer to page G-190 for Frames.

Bore Size	Frame Series
3/4" to 1"	10
1 1/8" to 1 7/16"	23
1 1/2" to 2S"	31
2" to 2 3/16"	39

Metric dimensions for reference only.

Mounted Ball Bearings *Browning*

Mtd. Ball Bearings



- Duty:** Intermediate
- Rolling Elements:** Ball
- Housing:** Cast Iron Wide Slot Take Up
- Self Alignment:** +/- 1.5 Degrees
- Lock:** Eccentric
- Seal:** Contact
- Temperature:** -20° to 200°F

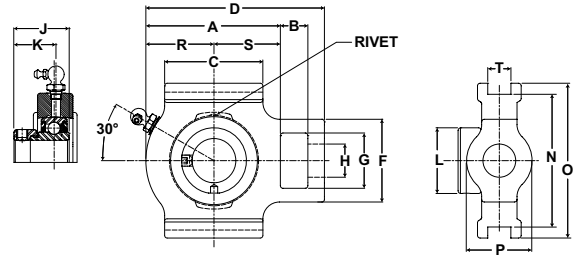

VTWE 100 Series Intermediate Duty Wide Slot Take Ups - Eccentric Locking

Bore Diameter inch	Part No.	Bearing Insert No.	Basic Dynamic Rating lb/N	Dimensions inch / mm															Unit Wt. lb/kg	
				A	B	C	D	F	G	H Core	J	K	L	N	O	P Hub	R	S		T
3/4	VTWE-112	VE-112	2611 11614	3 76.2	5/8 15.9	2 1/4 57.2	4 101.6	1 7/8 47.6	1 1/4 31.8	3/4 19.1	1 17/64 32.1	59/64 23.4	1 5/16 33.3	3 76.2	3 1/2 88.9	1 3/8 34.9	1 7/16 36.5	1 9/16 39.7	17/32 13.5	1.8 .82
7/8	VTWE-114	VE-114	2801	3 5/64 78.2	5/8 15.9	2 1/4 57.2	4 3/32 104.0	1 7/8 47.6	1 1/4 31.8	3/4 19.1	1 17/64 32.1	59/64 23.4	1 1/2 38.1	3 76.2	3 1/2 88.9	1 1/2 38.1	1 9/16 39.7	1 17/32 38.9	17/32 13.5	1.9 .86
15/16	VTWE-115	VE-115	12459																	
1	VTWE-116	VE-116																		
1 1/8	VTWE-118	VE-118	4381	3 3/8 85.7	3/4 19.1	2 1/2 63.5	4 5/8 117.5	2 1/8 54.0	1 7/16 36.5	7/8 22.2	1 27/64 36.1	1 3/64 26.6	1 3/4 44.5	3 1/2 88.9	4 101.6	1 3/4 44.5	1 25/32 45.2	1 19/32 40.5	17/32 13.5	2.8 1.27
1 3/16	VTWE-119	VE-119	19487																	
1 1/4	VTWE-120S	VE-120S																		
1 1/4	VTWE-120	VE-120	5782	3 3/4 95.3	3/4 19.1	2 3/4 69.9	5 127.0	2 1/8 54.0	1 7/16 36.5	7/8 22.2	1 37/64 40.1	1 5/32 29.4	2 3/16 55.6	3 1/2 88.9	4 101.6	1 3/4 44.5	2 50.8	1 3/4 44.5	17/32 13.5	3.5 1.59
1 3/8	VTWE-122	VE-122	25718																	
1 7/16	VTWE-123	VE-123																		
1 1/2	VTWE-124	VE-124	7340 32648	4 7/32 107.2	3/4 19.1	3 1/4 82.6	5 19/32 142.1	2 3/4 69.9	1 15/16 49.2	1 1/8 28.6	1 49/64 44.8	1 9/32 32.5	2 3/8 60.3	4 101.6	4 1/2 114.3	2 1/8 54.0	2 3/16 55.6	2 1/32 51.6	11/16 17.5	5.2 2.36
1 11/16	VTWE-127	VE-127	7901	4 3/8 111.1	3/4 19.1	3 1/4 82.6	5-3/4 146.1	2 3/4 69.9	1 15/16 49.2	1 1/8 28.6	1 49/64 44.8	1 9/32 32.5	2 1/2 63.5	4 101.6	4 1/2 114.3	2 1/8 54.0	2 1/4 57.2	2 1/8 54.0	11/16 17.5	5.8 2.63
1 3/4	VTWE-128	VE-128	35144																	
1 15/16	VTWE-131	VE-131	7889	4 17/32 115.1	3/4 19.1	3 3/8 85.7	5 29/32 150.0	2 3/4 69.9	1 15/16 49.2	1 1/8 28.6	1 25/32 45.2	1 9/32 32.5	2 3/4 69.9	4 101.6	4 1/2 114.3	2 1/8 54.0	2 5/16 58.7	2 7/32 56.4	11/16 17.5	6.1 2.77
2	VTWE-132S	VE-132S	35090																	
2	VTWE-132	VE-132	9752	5 3/32 129.4	1 25.4	3 3/4 95.3	6 27/32 173.8	3 5/8 92.1	2 1/2 63.5	1 3/8 34.9	1 63/64 50.4	1 7/16 36.5	3 76.2	5 1/8 130.2	5 3/4 146.1	2 1/2 63.5	2 9/16 65.1	2 17/32 64.3	1 1/16 27.0	8.7 3.95
2 3/16	VTWE-135	VE-135	43377																	

Refer to page G-190 for Frames.

Bore Size	Frame Series
3/4" to 1"	10
1 1/8" to 1 7/16"	23
1 1/2" to 2S"	31
2" to 2 3/16"	39

Metric dimensions for reference only.

Browning[®] Mounted Ball Bearings



- Duty:** Standard
- Rolling Elements:** Ball
- Housing:** Cast Iron Wide Slot Take Up
- Self Alignment:** +/- 1.5 Degrees
- Lock:** Setscrew
- Seal:** Contact and Flinger
- Temperature:** -20° to 200°F

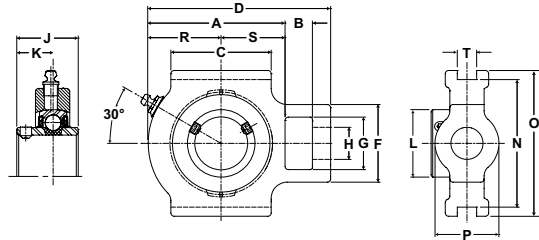

VTWS 200 Series Standard Duty Wide Slot Take Ups - Setscrew Locking

Bore Diameter inch	Part No.	Bearing Insert No.	Basic Dynamic Rating lb/N	Dimensions inch / mm																Unit Wt. lb/kg
				A	B	C	D	F	G	H Core	J	K	L	N	O	P Hub	R	S	T	
1/2	VTWS-208	VS-208	2108	2 11/16	5/8	2	3 11/16	1 7/8	1 1/4	3/4	1 1/32	5/8	31/32	3	3 1/2	1 3/8	1 5/16	1 3/8	17/32	1.5
5/8	VTWS-210	VS-210	9377	68.3	15.9	50.8	93.7	47.6	31.8	19.1	26.2	15.9	24.6	76.2	88.9	34.9	33.3	34.9	13.5	.68
3/4	VTWS-212	VS-212	2611 11614	3	5/8	2 1/4	4	1 7/8	1 1/4	3/4	1 7/32	23/32	1 3/16	3	3 1/2	1 3/8	1 7/16	1 9/16	17/32	1.7
7/8	VTWS-214	VS-214	2801	3 5/64	5/8	2 1/4	4 3/32	1 7/8	1 1/4	3/4	1 3/8	13/16	1 3/8	3	3 1/2	1 1/2	1 9/16	1 17/32	17/32	1.6
15/16	VTWS-215	VS-215	12459	78.2	15.9	57.2	104.0	47.6	31.8	19.1	34.9	20.6	34.9	76.2	88.9	38.1	39.7	38.9	13.5	.73
1	VTWS-216	VS-216																		
1 1/8	VTWS-218	VS-218	4381	3 3/8	3/4	2 1/2	4 5/8	2 1/8	1 7/16	7/8	1 1/2	7/8	1 19/32	3 1/2	4	1 3/4	1 25/32	1 19/32	17/32	2.4
1 3/16	VTWS-219	VS-219	19487	85.7	19.1	63.5	117.5	54.0	36.5	22.2	38.1	22.2	40.5	88.9	101.6	44.5	45.2	40.5	13.5	1.09
1 1/4	VTWS-220	VS-220	5782	3 3/4	3/4	2 3/4	5	2 1/8	1 7/16	7/8	1 11/16	1	1 55/64	3 1/2	4	1 3/4	2	1 3/4	17/32	3.3
1 3/8	VTWS-222	VS-222	25718	95.3	19.1	69.9	127.0	54.0	36.5	22.2	42.9	25.4	47.2	88.9	101.6	44.5	50.8	44.5	13.5	1.50
1 7/16	VTWS-223	VS-223																		
1 1/2	VTWS-224	VS-224	7340 32648	4 7/32	3/4	3 1/4	5 19/32	2 3/4	1 15/16	1 1/8	1 15/16	1 3/16	2 1/16	4	4 1/2	2 1/8	2 3/16	2 1/32	11/16	5.0
				107.2	19.1	82.6	142.1	69.9	49.2	28.6	49.2	30.2	52.4	101.6	114.3	54.0	55.6	51.6	17.5	2.27
1 5/8	VTWS-226	VS-226	7901	4 3/8	3/4	3 1/4	5 3/4	2 3/4	1 15/16	1 1/8	1 15/16	1 3/16	2 19/64	4	4 1/2	2 1/8	2 1/4	2 1/8	11/16	5.6
1 11/16	VTWS-227	VS-227	35144	111.1	19.1	82.6	146.1	69.9	49.2	28.6	49.2	30.2	58.3	101.6	114.3	54.0	57.2	54.0	17.5	2.54
1 3/4	VTWS-228	VS-228																		
1 15/16	VTWS-231	VS-231	7889 35090	4 17/32	3/4	3 3/8	5 29/32	2 3/4	1 15/16	1 1/8	2 1/32	1 9/32	2 15/32	4	4 1/2	2 1/8	2 5/16	2 7/32	11/16	5.8
				115.1	19.1	85.7	150.0	69.9	49.2	28.6	51.6	32.5	62.7	101.6	114.3	54.0	58.7	56.4	17.5	2.63
2	VTWS-232	VS-232	9752	5 3/32	1	3 3/4	6 27/32	3 5/8	2 1/2	1 3/8	2 3/16	1 5/16	2 23/32	5 1/8	5 3/4	2 1/2	2 9/16	2 17/32	1 1/16	8.4
2 3/16	VTWS-235	VS-235	43377	129.4	25.4	95.3	173.8	92.1	63.5	34.9	55.6	33.3	69.1	130.2	146.1	63.5	65.1	64.3	27.0	3.81
2 7/16	VTWS-239	VS-239	11789 52437	5 1/2	1	4	7 1/4	3 5/8	2 1/2	1 3/8	2 9/16	1 9/16	2 63/64	5 1/8	5 3/4	2 1/2	2 27/32	2 21/32	1 1/16	9.3
				139.7	25.4	101.6	184.2	92.1	63.5	34.9	65.1	39.7	75.8	130.2	146.1	63.5	72.2	67.5	27.0	4.22

Refer to page G-190 for Frames.

Bore Size	Frame Series
1/2" to 1"	10
1 1/8" to 1 7/16"	23
1 1/2" to 2S"	31
2" to 2 7/16"	39

Metric dimensions for reference only.

Mounted Ball Bearings *Browning*

Mtd. Ball Bearings



- Duty:** Standard
- Rolling Elements:** Ball
- Housing:** Cast Iron Wide Slot Take Up
- Self Alignment:** +/- 1.5 Degrees
- Lock:** Eccentric
- Seal:** Contact and Flinger
- Temperature:** -20° to 200°F

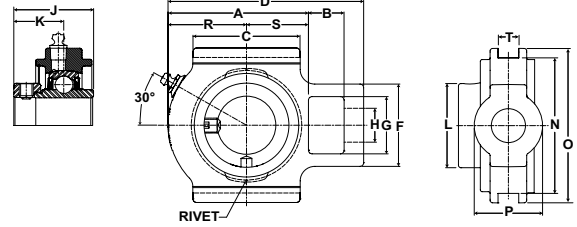

VTWE 200 Series Standard Duty Wide Slot Take Ups - Eccentric Locking

Bore Diameter inch	Part No.	Bearing Insert No.	Basic Dynamic Rating lb/N	Dimensions inch / mm																Unit Wt. lb/kg
				A	B	C	D	F	G	H Core	J	K	L	N	O	P Hub	R	S	T	
3/4	VTWE-212	VE-212	2611 11614	3 76.2	5/8 15.9	2 1/4 57.2	4 101.6	1 7/8 47.6	1 1/4 31.8	3/4 19.1	1 23/32 43.7	1 3/64 26.6	1 5/16 33.3	3 76.2	3 1/2 88.9	1 3/8 34.9	1 7/16 36.5	1 9/16 39.7	17/32 13.5	1.8 .82
7/8	VTWE-214	VE-214	2801 12459	3 5/64 78.2	5/8 15.9	2 1/4 57.2	4 3/32 104.0	1 7/8 47.6	1 1/4 31.8	3/4 19.1	1 3/4 44.5	1 1/16 27.0	1 1/2 38.1	3 76.2	3 1/2 88.9	1 1/2 38.1	1 9/16 39.7	1 17/32 38.9	17/32 13.5	1.9 .86
15/16	VTWE-215	VE-215																		
1	VTWE-216	VE-216																		
1 1/8	VTWE-218	VE-218	4381	3 3/8 85.7	3/4 19.1	2 1/2 63.5	4 5/8 117.5	2 1/8 54.0	1 7/16 36.5	7/8 22.2	1 29/32 48.4	1 3/16 30.2	1 3/4 44.5	3 1/2 88.9	4 101.6	1 3/4 44.5	1 25/32 45.2	1 19/32 40.5	17/32 13.5	2.8 1.27
1 3/16	VTWE-219	VE-219	19487																	
1 1/4	VTWE-220	VE-220	5782 25718	3 3/4 95.3	3/4 19.1	2 3/4 69.9	5 127.0	2 1/8 54.0	1 7/16 36.5	7/8 22.2	2 1/64 51.2	1 9/32 32.5	2 3/16 55.6	3 1/2 88.9	4 101.6	1 3/4 44.5	2 50.8	1 3/4 44.5	17/32 13.5	3.5 1.59
1 3/8	VTWE-222	VE-222																		
1 7/16	VTWE-223	VE-223																		
1 1/2	VTWE-224	VE-224	7340 32648	4 7/32 107.2	3/4 19.1	3 1/4 82.6	5 19/32 142.1	2 3/4 69.9	1 15/16 49.2	1 1/8 28.6	2 7/32 56.4	1 3/8 34.9	2 3/8 60.3	4 101.6	4 1/2 114.3	2 1/8 54.0	2 3/16 55.6	2 1/32 51.6	11/16 17.5	5.2 2.36
1 5/8	VTWE-226	VE-226	7901 35144	4 3/8 111.1	3/4 19.1	3 1/4 82.6	5 3/4 146.1	2 3/4 69.9	1 15/16 49.2	1 1/8 28.6	2 7/32 56.4	1 3/8 34.9	2 1/2 63.5	4 101.6	4 1/2 114.3	2 1/8 54.0	2 1/4 57.2	2 1/8 54.0	11/16 17.5	5.8 2.63
1 11/16	VTWE-227	VE-227																		
1 3/4	VTWE-228	VE-228																		
1 15/16	VTWE-231	VE-231	7889 35090	4 17/32 115.1	3/4 19.1	3 3/8 85.7	5 29/32 150.0	2 3/4 69.9	1 15/16 49.2	1 1/8 28.6	2 15/32 62.7	1 1/2 38.1	2 3/4 69.9	4 101.6	4 1/2 114.3	2 1/8 54.0	2 5/16 58.7	2 7/32 56.4	11/16 17.5	6.1 2.77
2	VTWE-232	VE-232	9752 43377	5 3/32 129.4	1 25.4	3 3/4 95.3	6 27/32 173.8	3 5/8 92.1	2 1/2 63.5	1 3/8 34.9	2 13/16 71.4	1 23/32 43.7	3 76.2	5 1/8 130.2	5 3/4 146.1	2 1/2 63.5	2 9/16 65.1	2 17/32 64.3	1 1/16 27.0	8.7 3.95
2 3/16	VTWE-235	VE-235																		
2 7/16	VTWE-239	VE-239	11789 52437	5 1/2 139.7	1 25.4	4 101.6	7 1/4 184.2	3 5/8 92.1	2 1/2 63.5	1 3/8 34.9	3 1/16 77.8	1 27/32 46.8	3 3/8 85.7	5 1/8 130.2	5 3/4 146.1	2 1/2 63.5	2 27/32 72.2	2 21/32 67.5	1 1/16 27.0	9.6 4.35

Refer to page G-190 for Frames.

Bore Size	Frame Series
3/4" to 1"	10
1 1/8" to 1 7/16"	23
1 1/2" to 2S"	31
2" to 2 7/16"	39

Metric dimensions for reference only.

Browning[®] Mounted Ball Bearings



- Duty:** Medium
- Rolling Elements:** Ball
- Housing:** Cast Iron Wide Slot Take Up
- Self Alignment:** +/- 1.5 Degrees
- Lock:** Setscrew
- Seal:** Contact and Flinger
- Temperature:** -20° to 200°F

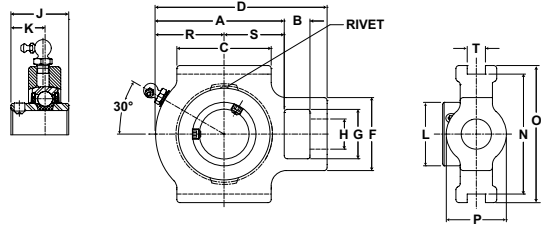

VTWS 300 Series Medium Duty Wide Slot Take Ups - Setscrew Locking

Bore Diameter inch	Part No.	Bearing Insert No.	Basic Dynamic Rating lb/N	Dimensions inch / mm																Unit Wt. lb/kg
				A	B	C	D	F	G	H Core	K	J D	L	N	O	P Hub	R	S	T	
1	VTWS-316	VS-316	4381 19487	3 3/8 85.7	3/4 19.1	2 1/2 63.5	4 5/8 117.5	2 1/8 54.0	1 7/16 36.5	7/8 22.2	7/8 22.2	1 1/2 38.1	1 19/32 40.5	3 1/2 88.9	4 101.6	1 3/4 44.5	1 25/32 45.2	1 19/32 40.5	17/32 13.5	3.1 1.41
1 3/16	VTWS-319	VS-319	5782 25718	3 3/4 95.3	3/4 19.1	2 3/4 69.9	5 127.0	2 1/8 54.0	1 7/16 36.5	7/8 22.2	1 25.4	1 11/16 42.9	1 55/64 47.2	3 1/2 88.9	4 101.6	1 3/4 44.5	2 50.8	1 3/4 44.5	17/32 13.5	4.0 1.81
1 7/16	VTWS-323	VS-323	7340 32648	4 7/32 107.2	3/4 19.1	3 1/4 82.6	5 19/32 142.1	2 3/4 69.9	1 15/16 49.2	1 1/8 28.6	1 3/16 30.2	1 15/16 49.2	2 1/16 52.4	4 101.6	4 1/2 114.3	2 1/8 54.0	2 3/16 55.6	2 1/32 51.6	11/16 17.5	5.7 2.59
1 1/2	VTWS-324	VS-324	7901 35144	4 3/8 111.1	3/4 19.1	3 1/4 82.6	5 3/4 146.1	2 3/4 69.9	1 15/16 49.2	1 1/8 28.6	1 3/16 30.2	1 15/16 49.2	2 19/64 58.3	4 101.6	4 1/2 114.3	2 1/8 54.0	2 1/4 57.2	2 1/8 54.0	11/16 17.5	5.7 2.59
1 11/16 1 3/4	VTWS-327 VTWS-328	VS-327 VS-328	7889 35090	4 17/32 115.1	3/4 19.1	3 3/8 85.7	5 29/32 150.0	2 3/4 69.9	1 15/16 49.2	1 1/8 28.6	1 9/32 32.5	2 1/32 51.6	2 15/32 62.7	4 101.6	4 1/2 114.3	2 1/8 54.0	2 5/16 58.7	2 7/32 56.4	11/16 17.5	6.2 2.81
1 15/16 2	VTWS-331 VTWS-332	VS-331 VS-232	9752 4337	5 3/32 129.4	1 25.4	3 3/4 95.3	6 27/32 173.8	3 5/8 92.1	2 1/2 63.5	1 3/8 34.9	1 5/16 33.3	2 3/16 55.6	2 23/32 69.1	5 1/8 130.2	5 3/4 146.1	2 1/2 63.5	2 9/16 65.1	2 17/32 64.3	1 1/16 27.0	9.5 4.31
2 3/16 2 1/4	VTWS-335 VTWS-336	VS-335 VS-236	11789 52437	5 1/2 139.7	1 25.4	4 101.6	7 1/4 184.2	3 5/8 92.1	2 1/2 63.5	1 3/8 34.9	1 9/16 39.7	2 9/16 65.1	2 63/64 75.8	5 1/8 130.2	5 3/4 146.1	2 1/2 63.5	2 27/32 72.2	2 21/32 67.5	1 1/16 27.0	11.0 4.99

Refer to page G-190 for Frames.

Bore Size	Frame Series
1" to 1 3/16"	23
1 7/16" to 1 3/4"	31
1 15/16" to 2 1/4"	39

Metric dimensions for reference only.

Mounted Ball Bearings *Browning*

Mtd. Ball Bearings

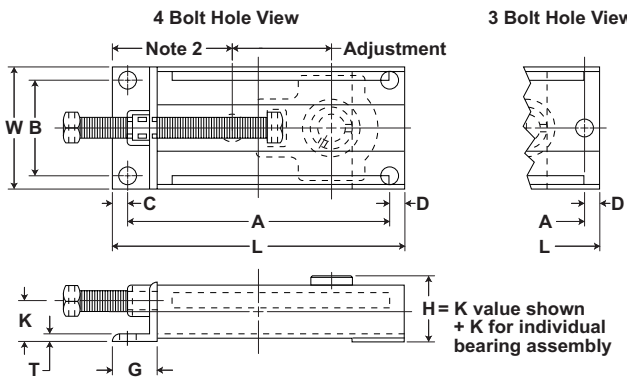

SF Series Standard Duty Center Pull Take-Up Frame

Bore Diameter Range			Frame Part No.	Adjustment	Dimensions inch / mm									Bolt Holes		Unit Wt. lb/kg
100 Series	200 Series	300 Series			L	A	W	B	C	D	G	K	T	No.	Size	
3/4 - 1"	1/2 - 1"	N/A	1SF10	1 1/2 38.1	7 177.8	6 152.4	4 1/16 103.2	3 3/16 81.0	1/2 12.7	1/2 12.7	1 1/2 38.1	1 3/8 34.9	1/4 6.4	3	9/16 14	3.3 1.50
			3SF16	3 76.2	8 1/2 215.9	7 1/2 190.5	4 1/16 103.2	3 3/16 81.0	1/2 12.7	1/2 12.7	1 1/2 38.1	1 3/8 34.9	1/4 6.4	3	9/16 14	3.9 1.77
			6SF16	6 152.4	11 1/2 292.1	10 1/2 266.7	4 1/16 103.2	3 3/16 81.0	1/2 12.7	1/2 12.7	1 1/2 38.1	1 3/8 34.9	1/4 6.4	3	9/16 14	5.1 2.31
			9SF16	9 228.6	14 1/2 368.3	13 1/2 342.9	4 1/16 103.2	3 3/16 81.0	1/2 12.7	1/2 12.7	1 1/2 38.1	1 3/8 34.9	1/4 6.4	3	9/16 14	6.2 2.81
1 1/8 - 1 7/16"	1 1/8 - 1 7/16"	1 - 1 3/16"	3SF23	3 76.2	9 3/8 238.1	8 3/8 212.7	11 3/8 288.9	3 11/16 93.7	1/2 12.7	1/2 12.7	1 1/2 38.1	1 3/8 34.9	1/4 6.4	3	9/16 14	5.4 2.45
			6SF23	6 152.4	12 3/8 314.3	11 3/8 288.9	11 3/8 288.9	3 11/16 93.7	1/2 12.7	1/2 12.7	1 1/2 38.1	1 3/8 34.9	1/4 6.4	3	9/16 14	6.7 5.1
			9SF23	9 228.6	15 3/8 390.5	14 3/8 365.1	11 3/8 288.9	3 11/16 93.7	1/2 12.7	1/2 12.7	1 1/2 38.1	1 3/8 34.9	1/4 6.4	3	9/16 14	8.1 3.67
			12SF23	12 304.8	18 3/8 466.7	17 3/8 441.3	11 3/8 288.9	3 11/16 93.7	1/2 12.7	1/2 12.7	1 1/2 38.1	1 3/8 34.9	1/4 6.4	3	9/16 14	9.5 4.31
1 1/2 - 2S"	1 1/2 - 2S"	1 7/16 - 1 3/4"	3SF31	3 76.2	11 279.4	9 7/8 250.8	5 1/16 128.6	3 1/16 77.8	1/2 12.7	5/8 15.9	1 1/2 38.1	1 5/8 41.3	1/4 6.4	4	9/16 14	7.4 3.36
			6SF31	6 152.4	14 355.6	12 7/8 327.0	5 1/16 128.6	3 1/16 77.8	1/2 12.7	5/8 15.9	1 1/2 38.1	1 5/8 41.3	1/4 6.4	4	9/16 14	9.1 4.13
			9SF31	9 228.6	17 431.8	15 7/8 403.2	5 1/16 128.6	3 1/16 77.8	1/2 12.7	5/8 15.9	1 1/2 38.1	1 5/8 41.3	1/4 6.4	4	9/16 14	10.8 5.1
			12SF31	12 304.8	20 508.0	18 7/8 479.4	5 1/16 128.6	3 1/16 77.8	1/2 12.7	5/8 15.9	1 1/2 38.1	1 5/8 41.3	1/4 6.4	4	9/16 14	12.5 5.67
			18SF31	18 457.2	26 660.4	24 7/8 631.8	5 1/16 128.6	3 1/16 77.8	1/2 12.7	5/8 15.9	1 1/2 38.1	1 5/8 41.3	1/4 6.4	4	9/16 14	15.9 7.21
2 - 2 3/16"	2 - 2 7/16"	1 15/16 - 2 1/4"	9SF39	9 228.6	18 1/4 463.6	16 7/8 428.6	6 3/8 161.9	4 1/8 104.8	5/8 15.9	3/4 19.1	2 50.8	1 7/8 47.6	5/8 15.9	4	11/16 17	20 5.1
			12SF39	12 304.8	21 1/4 539.8	19 7/8 504.8	6 3/8 161.9	4 1/8 104.8	5/8 15.9	3/4 19.1	2 50.8	1 7/8 47.6	5/8 15.9	4	11/16 17	22.8 5.1
			18SF39	18 457.2	27 1/4 692.2	25 7/8 657.2	6 3/8 161.9	4 1/8 104.8	5/8 15.9	3/4 19.1	2 50.8	1 7/8 47.6	5/8 15.9	4	11/16 17	28.2 5.1

Note:
 1. Bearing sold separately.
 2. Dimension variable based on housing. To calculate use G in table above + D - R from housing tables shown on prior pages.
 Metric dimensions for reference only.
 Not all parts are available from stock. Please contact customer service for availability (800) 626-2120.
 For more information on bearing capabilities outside of our standard offering, please contact Application Engineering (800) 626-2093.

Browning[®] Mounted Ball Bearings

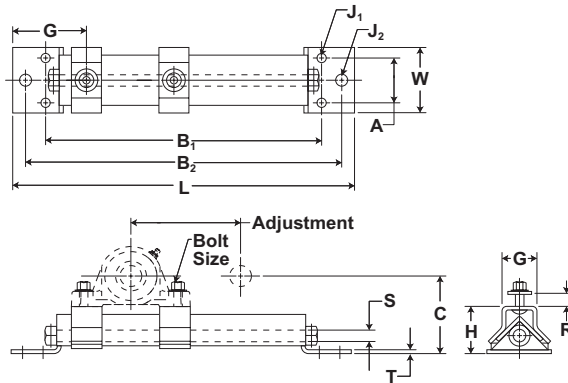
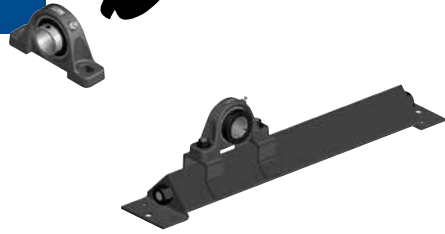

TF Series Standard Duty Top Mount Take-Up Frame

Bore Diameter Range	Frame Part No.	Adjustment	Dimensions Inch / Mm													Bolt Size	Unit Wt. lb/kg
			L	B1	B2	W	A	C	G MIN	H	J1	J2	R	S	T		
3/4 - 1"	6TF16	6 152.4	17 1/8 435.0	13 7/8 352.4	15 7/8 403.2	3 1/4 82.6	2 1/4 57.2	1 3/4 44.5	3 5/16 84.1	2 3/8 60.3	7/16 11.1	9/16 14.3	9/16 14.3	5/8 15.9	3/16 4.8	3/8 10	6.0 2.72
	9TF16	9 228.6	20 1/8 511.2	16 7/8 428.6	18 7/8 479.4	3 1/4 82.6	2 1/4 57.2	1 3/4 44.5	3 5/16 84.1	2 3/8 60.3	7/16 11.1	9/16 14.3	9/16 14.3	5/8 15.9	3/16 4.8	3/8 10	6.7 3.04
1 1/16 - 1 15/16"	6TF31	6 152.4	18 3/16 462.0	15 7/16 392.1	16 15/16 430.2	3 1/2 88.9	2 1/2 63.5	2 5/16 58.7	3 3/8 85.7	2 13/16 71.4	7/16 11.1	9/16 14.3	7/8 22.2	3/4 19.1	3/16 4.8	1/2 13	8.9 4.04
	9TF31	9 228.6	22 5/8 574.7	19 7/8 504.8	21 3/8 542.9	3 1/2 88.9	2 1/2 63.5	2 5/16 58.7	3 3/8 85.7	2 13/16 71.4	7/16 11.1	9/16 14.3	7/8 22.2	3/4 19.1	3/16 4.8	1/2 13	10.3 4.67
	12TF31	12 304.8	24 3/16 614.4	21 7/16 544.5	22 15/16 582.6	3 1/2 88.9	2 1/2 63.5	2 5/16 58.7	3 3/8 85.7	2 13/16 71.4	7/16 11.1	9/16 14.3	7/8 22.2	3/4 19.1	3/16 4.8	1/2 13	10.9 4.94
	18TF31	18 457.2	31 5/8 803.3	28 7/8 733.4	30 3/8 771.5	3 1/2 88.9	2 1/2 63.5	2 5/16 58.7	3 3/8 85.7	2 13/16 71.4	7/16 11.1	9/16 14.3	7/8 22.2	3/4 19.1	3/16 4.8	1/2 13	13.3 6.03
2 - 2 7/16"	12TF39	12 304.8	28 711.2	24 3/4 628.7	26 3/4 679.5	4 1/2 114.3	3 76.2	2 5/8 66.7	4 101.6	3 5/16 84.1	9/16 14.3	11/16 17.5	15/16 23.8	1 25.4	1/4 6.4	5/8 16	18.3 8.30
	18TF39	18 457.2	34 863.6	30 3/4 781.1	32 3/4 831.9	4 1/2 114.3	3 76.2	2 5/8 66.7	4 101.6	3 5/16 84.1	9/16 14.3	11/16 17.5	15/16 23.8	1 25.4	1/4 6.4	5/8 16	21.20 9.62

Metric dimensions for reference only.

Not all parts are available from stock. Please contact customer service for availability (800) 626-2120.

For more information on bearing capabilities outside of our standard offering, please contact Application Engineering (800) 626-2093.

Mounted Ball Bearings *Browning*



Duty: Intermediate
Rolling Elements: Ball
Housing: Ductile Iron Pillow Block
Self Alignment: +/- 1.5 Degrees
Lock: Setscrew
Seal: Contact
Temperature: -20° to 200°F

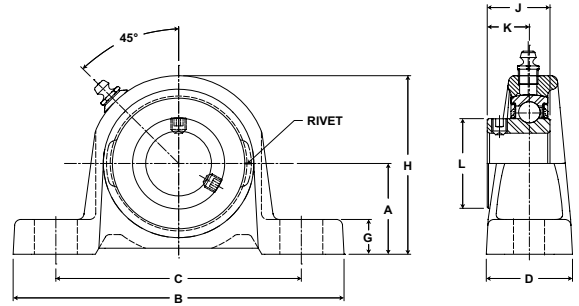

VPS 100-M Series Intermediate Duty Ductile Iron Pillow Blocks - Setscrew Locking

Bore Diameter inch	Part No.	Bearing Insert No.	Basic Dynamic Rating lb/N	Dimensions inch / mm										Bolt Size	Unit Wt. lb/kg
				A	B	C		D	G	H	J	K	L		
						min.	max.								
1/2	VPS-108M	VS-108	2108	1 3/16 30.2	4 7/16 112.7	3 5/32 80.2	3 23/32 94.5	1 25.4	11/32 8.7	2 5/32 54.8	15/16 23.8	5/8 15.9	31/32 24.6	3/8	.7 .32
5/8	VPS-110M	VS-110	9377												
3/4	VPS-112M	VS-112	2611 11614	1 5/16 33.3	4 3/4 120.7	3 15/32 88.1	4 1/32 102.4	1 1/16 27.0	3/8 9.5	2 7/16 61.9	1 1/16 27.0	23/32 18.3	1 3/16 30.2	3/8	0.9 .41
15/16	VPS-115M	VS-115	2801	1 7/16 36.5	5 127.0	3 21/32 92.9	4 7/32 107.2	1 1/8 28.6	13/32 10.3	2 11/16 68.3	1 7/64 28.2	49/64 19.4	1 3/8 34.9	3/8	1.1 .50
1	VPS-116M	VS-116	12459												
1 3/16	VPS-119M	VS-119	4381	1 11/16 42.9	5 15/16 150.8	4 3/8 111.1	5 1/16 128.6	1 5/16 33.3	13/32 10.3	3 5/32 80.2	1 5/32 29.4	25/32 19.8	1 19/32 40.5	1/2	1.6 .73
1 1/4	VPS-120SM	VS-120S	19487												
1 1/4	VPS-120M	VS-120	5782	1 7/8 47.6	6 1/4 158.8	4 21/32 118.3	5 11/32 135.7	1 3/8 34.9	7/16 11.1	3 9/16 90.5	1 9/32 32.5	55/64 21.8	1 55/64 47.2	1/2	2.4 1.09
1 3/8	VPS-122M	VS-122	25718												
1 7/16	VPS-123M	VS-123													

Browning® Mounted Ball Bearings



Duty: Intermediate
Rolling Elements: Ball
Housing: Ductile Iron Two Bolt Flange
Self Alignment: +/- 1.5 Degrees
Lock: Setscrew
Seal: Contact
Temperature: -20° to 200°F

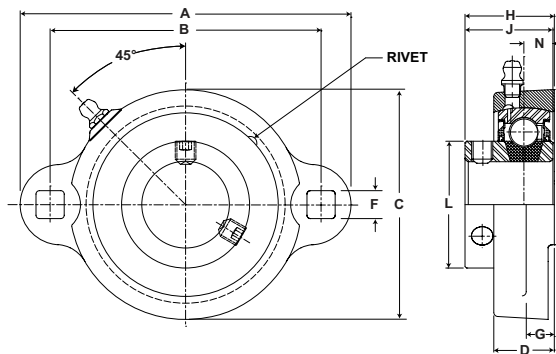

VF2S 100-M Series Intermediate Duty Ductile Iron Two Bolt Flanges - Setscrew Locking

Bore Diameter inch	Part No.	Bearing Insert No.	Basic Dynamic Rating lb/N	Dimensions inch / mm										Bolt Size	Unit Wt. lb/kg
				A	B	C	D	F Square	G	H	J	L	N		
1/2	VF2S-108M	VS-108	2108	3 3/16	2 1/2	1 15/16	5/8	19/64	13/32	31/32	15/16	31/32	5/16	1/4	.6
5/8	VF2S-110M	VS-110	9377	81.0	63.5	49.2	15.9	7.5	10.3	24.6	23.8	24.6	7.9		.27
3/4	VF2S-112M	VS-112	2611 11614	3 9/16	2 13/16	2 1/4	23/32	23/64	7/16	1 7/64	1 1/16	1 3/16	11/32	5/16	.9 .41
7/8	VF2S-114M	VS-114	2801 12459	3 3/4	3	2 1/2	25/32	23/64	7/16	1 3/16	1 7/64	1 3/8	11/32	5/16	1.0 .45
15/16	VF2S-115M	VS-115		95.3	76.2	63.5	19.8	9.1	11.1	30.2	28.2	34.9	8.7		
1	VF2S-116M	VS-116													
1 1/8	VF2S-118M	VS-118	4381 19487	4 7/16	3 9/16	2 15/16	29/32	27/64	15/32	1 17/64	1 5/32	1 19/32	3/8	3/8	1.5 .68
1 3/16	VF2S-119M	VS-119		112.7	90.5	74.6	23.0	10.7	11.9	32.1	29.4	40.5	9.5		
1 1/4	VF2S-120SM	VS-120S													
1 1/4	VF2S-120M	VS-120	5782 25718	4 13/16	3 15/16	3 3/8	31/32	27/64	1/2	1 25/64	1 9/32	1 35/64	27/64	3/8	1.9 .86
1 3/8	VF2S-122M	VS-122		122.2	100.0	85.7	24.6	10.7	12.7	35.3	32.5	39.3	10.7		
1 7/16	VF2S-123M	VS-123													

Metric dimensions for reference only.

Not all parts are available from stock. Please contact customer service for availability (800) 626-2120.

For more information on bearing capabilities outside of our standard offering, please contact Application Engineering (800) 626-2093.

Mounted Ball Bearings *Browning*

Mtd. Ball Bearings



- Duty:** Intermediate
- Rolling Elements:** Ball
- Housing:** Ductile Iron Three Bolt Flange
- Self Alignment:** +/- 1.5 Degrees
- Lock:** Setscrew
- Seal:** Contact
- Temperature:** -20° to 200°F

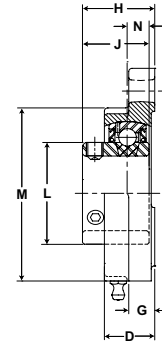
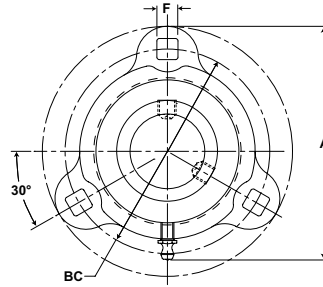

VF3S 100-M Series Intermediate Duty Ductile Iron Three Bolt Flanges - Setscrew Locking

Bore Diameter inch	Part No.	Bearing Insert No.	Basic Dynamic Rating lb/N	Dimensions inch / mm										Bolt Size	Unit Wt. lb/kg
				A	BC	D	F Square	G	H	J	L	M	N		
1/2	VF3S-108M	VS-108	2108	3 3/16	2 1/2	5/8	19/64	13/32	31/32	15/16	31/32	1 15/16	5/16	1/4	.60
5/8	VF3S-110M	VS-110	9377	81.0	63.5	15.9	7.5	10.3	24.6	23.8	24.6	49.2	7.9		.27
3/4	VF3S-112M	VS-112	2611 11614	3 9/16	2 13/16	23/32	23/64	7/16	1 7/64	1 1/16	1 3/16	2 1/4	11/32	5/16	.81 .37
7/8	VF3S-114M	VS-114	2801 12459	3 3/4	3	25/32	23/64	7/16	1 3/16	1 7/64	1 3/8	2 1/2	11/32	5/16	1.05 .48
15/16	VF3S-115M	VS-115		95.3	76.2	19.8	9.1	11.1	30.2	28.2	34.9	63.5	8.7		
1	VF3S-116M	VS-116													
1 1/8	VF3S-118M	VS-118	4381 19487	4 7/16	3 9/16	29/32	27/64	15/32	1 17/64	1 5/32	1 19/32	2 15/16	3/8	3/8	1.50 .68
1 3/16	VF3S-119M	VS-119		112.7	90.5	23.0	10.7	11.9	32.1	29.4	40.5	74.6	9.5		
1 1/4	VF3S-120SM	VS-120S													
1 1/4	VF3S-120M	VS-120	5782 25718	4 13/16	3 15/16	31/32	27/64	1/2	1 25/64	1 9/32	1 55/64	3 3/8	27/64	3/8	2.00 .91
1 3/8	VF3S-122M	VS-122		122.2	100.0	24.6	10.7	12.7	35.3	32.5	47.2	85.7	10.7		
1 7/16	VF3S-123M	VS-123													

Browning®

Mounted Ball Bearings



Duty: Light
Rolling Elements: Ball
Housing: Stamped Steel Pillow Block
Self Alignment: +/- 1.5 Degrees
Lock: Setscrew
Seal: Contact
Temperature: -20° to 200°F
Relube: No

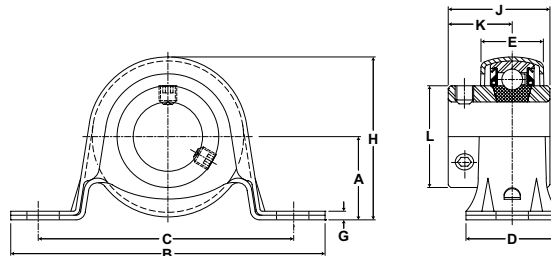

SSPS 100 Series Light Duty Stamped Steel Pillow Blocks - Setscrew Locking

Bore Diameter inch	Max Radial Load lb/N	Part No.	Bearing Insert No.	Dimensions inch / mm										Bolt Size	Unit Wt. lb/kg
				A	B	C	D	E	G	H	J	K	L		
7/8	400 1779	SSPS-114	LRS-114											3/8	.6 .27
15/16		SSPS-115	LRS-115	1 1/8 28.6	4 1/4 108.0	3 3/8 85.7	1 1/4 31.8	27/32 21.4	1/8 3.2	2 13/64 56.0	1 3/8 34.9	7/8 22.2	1 3/8 34.9		
1		SSPS-116	LRS-116												
1 1/8	600 2669	SSPS-118	LRS-118											3/8	1.0 .45
1 3/16		SSPS-119	LRS-119	1 5/16 33.3	4 5/8 117.5	3 3/4 95.3	1 3/8 34.9	61/64 24.2	5/32 4.0	2 19/32 65.9	1 19/32 40.5	7/8 22.2	1 19/32 40.5		
1 1/4		SSPS-120S	LRS-120S												

Metric dimensions for reference only.

Not all parts are available from stock. Please contact customer service for availability (800) 626-2120.

For more information on bearing capabilities outside of our standard offering, please contact Application Engineering (800) 626-2093.

Mounted Ball Bearings *Browning*



- Duty:** Light
- Rolling Elements:** Ball
- Housing:** Stamped Steel with Rubber Grommet Pillow Block
- Self Alignment:** +/- 1.5 Degrees
- Lock:** Setscrew
- Seal:** Contact
- Temperature:** -20° to 200°F
- Relube:** No

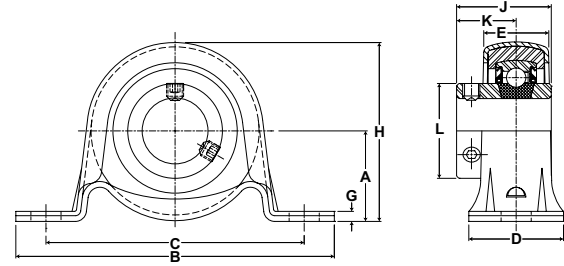

SSRPS 100 Series Light Duty Stamped Steel with Rubber Grommet Pillow Blocks - Setscrew Locking

Bore Diameter inch	Max Radial Load lb/N	Part No.	Bearing Insert No.	Dimensions inch / mm										Bolt Size	Unit Wt. lb/kg										
				A	B	C	D	E	G	H	J	K	L												
3/4	250	SSRPS-112	LRS-112	1 1/8	4 1/4	3 3/8	1 1/4	27/32	1/8	2 13/64	1 7/32	13/16	1 3/16	3/8	0.6										
	1112			28.6	108.0	85.7	31.8	21.4	3.2	56.0	31.0	20.6	30.2		.27										
7/8	300	SSRPS-114	LRS-114	1 5/16	4 5/8	3 3/4	1 3/8	61/64	5/32	2 19/32	1 3/8	55/64	1 3/8	3/8	0.8										
15/16	1334	SSRPS-115	LRS-115													33.3	117.5	95.3	34.9	24.2	4.0	65.9	21.8	34.9	.36
1		SSRPS-116	LRS-116																						

Browning[®] Mounted Ball Bearings



- Duty:** Light
- Rolling Elements:** Ball
- Housing:** Stamped Steel Four Bolt Flange
- Self Alignment:** +/- 1.5 Degrees
- Lock:** Setscrew
- Seal:** Contact
- Temperature:** -20° to 200°F
- Relube:** No

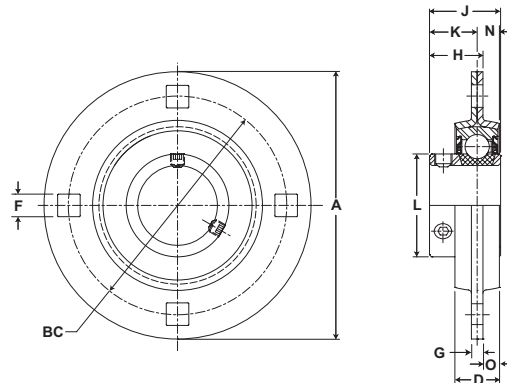

SSF4S 100 Series Light Duty Stamped Steel Four Bolt Flanges - Setscrew Locking

Bore Diameter inch	Max Radial Load lb/N	Part No.	Bearing Insert No.	Dimensions inch / mm										Bolt Size	Unit Wt. lb/kg
				A	BC	F Square	G	H	J	L	M	N	O		
1 1/2	1700 7562	SSF4S-124	LS-124	5 13/16 147.6	4 11/16 119.1	17/32 13.5	17/64 6.7	1 5/64 27.4	1 27/64 36.1	2 1/16 52.4	3 7/16 87.3	31/64 12.3	11/32 8.7	1/2	3.5 1.59
1 11/16 1 3/4	1700 7562	SSF4S-127 SSF4S-128	LS-127 LS-128	5 7/8 149.2	4 3/4 120.7	17/32 13.5	17/64 6.7	1 3/32 27.8	1 7/16 36.5	2 19/64 58.3	3 5/8 92.1	31/64 12.3	11/32 8.7	1/2	3.9 1.77
1 15/16	1900 8451	SSF4S-131	LS-131	6 1/8 155.6	5 127.0	17/32 13.5	19/64 7.5	1 3/16 30.2	1 35/64 39.3	2 15/32 62.7	3 27/32 97.6	1/2 12.7	23/64 9.1	1/2	4.0 1.81

Metric dimensions for reference only.
 Not all parts are available from stock. Please contact customer service for availability (800) 626-2120.
 For more information on bearing capabilities outside of our standard offering, please contact Application Engineering (800) 626-2093.

Mounted Ball Bearings *Browning*



- Duty:** Light
- Rolling Elements:** Ball
- Housing:** Stamped Steel Three Bolt Flange
- Self Alignment:** +/- 1.5 Degrees
- Lock:** Setscrew
- Seal:** Contact
- Temperature:** -20° to 200°F
- Relube:** No

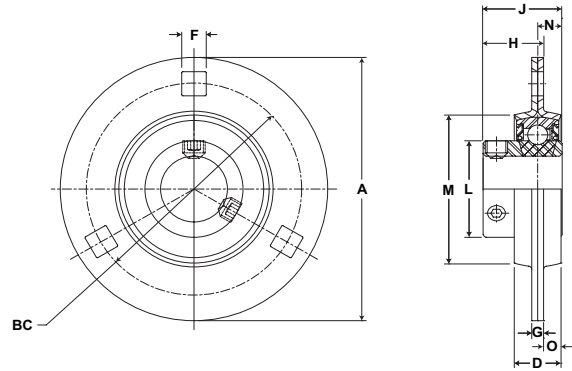

SSF3S 100 Series Light Duty Stamped Steel Three Bolt Flanges - Setscrew Locking

Bore Diameter inch	Steady Radial Load lb/N	Part No.	Bearing Insert No.	Dimensions inch / mm											Bolt Size	Unit Wt. lb/kg											
				A	BC	D	F Square	G	H	J	L	M	N	O													
3/4	700	SSF3S-112	LS-112	3 9/16	2 13/16	43/64	11/37	11/64	13/16	1 1/16	1 3/16	2 1/64	11/32	1/4	5/16	1.0 .45											
	3114			90.5	71.4	17.1	8.7	4.4	20.6	27.0	30.2	51.2	8.7	6.4													
7/8 15/16 1	800 3558	SSF3S-114	LS-114	3 3/4	3	43/64	11/32	11/64	55/64	1 7/64	1 3/8	2 7/32	11/32	1/4	5/16	1.3 .59											
		SSF3S-115	LS-115														95.3	76.2	17.1	8.7	4.4	21.8	28.2	34.9	56.4	8.7	6.4
		SSF3S-116	LS-116																								
1 1/8 1 3/16 1 1/4	1100 4893	SSF3S-118	LS-118	4 7/16	3 9/16	17/23	13/32	13/64	57/64	1 5/32	1 19/32	2 21/32	3/8	17/64	3/8	1.5 .68											
		SSF3S-119	LS-119														112.7	90.5	18.8	10.3	5.1	22.6	29.4	40.5	67.5	9.5	6.7
		SSF3S-120S	LS-120S																								
1 1/4 1 3/8 1 7/16	1400 6227	SSF3S-120	LS-120	4 13/16	3 15/16	53/64	13/32	13/64	31/32	1 9/32	1 55/64	3 1/16	27/64	5/16	3/8	1.8 .82											
		SSF3S-122	LS-122														122.2	100.0	21.0	10.3	5.1	24.6	32.5	47.2	77.8	10.7	7.9
		SSF3S-123	LS-123																								

Browning[®] Mounted Ball Bearings



Duty: Light
Rolling Elements: Ball
Housing: Stamped Steel Three Bolt Triangular Flange
Self Alignment: +/- 1.5 Degrees
Lock: Setscrew
Seal: Contact
Temperature: -20° to 200°F
Relube: No

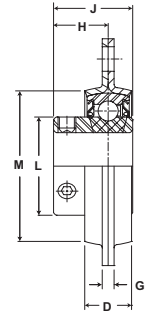
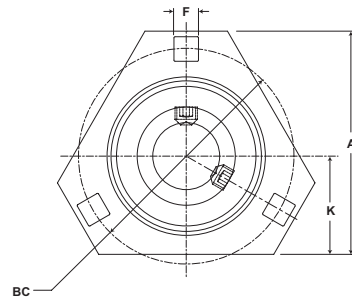

SSF3TS 100 Series Light Duty Stamped Steel Three Bolt Flanges - Setscrew Locking

Bore Diameter inch	Max Radial Load lb/N	Part No.	Bearing Insert No.	Dimensions inch / mm										Bolt Size	Unit Wt. lb/kg
				A	BC	D	F Square	G	J	H	K	L	M		
3/4	700 3114	SSF3TS-112	LS-112	3 76.2	2 13/16 71.4	21/32 16.7	11/32 8.7	11/64 4.2	1 1/16 27.0	23/32 18.3	1 5/16 33.3	1 3/16 30.2	2 1/64 51.2	5/16	1.0 .45
7/8 15/16 1	800 3558	SSF3TS-114 SSF3TS-115 SSF3TS-116	LS-114 LS-115 LS-116	3 1/8 79.4	3 76.2	21/32 16.7	11/32 8.7	11/64 4.2	1 7/64 28.2	49/64 19.4	1 3/8 34.9	1 3/8 34.9	2 7/32 56.4	5/16	1.1 .50
1 1/8 1 3/16 1 1/4	1100 4893	SSF3TS-118 SSF3TS-119 SSF3TS-120S	LS-118 LS-119 LS-120S	3 11/16 93.7	3 9/16 90.5	3/4 19.1	11/32 8.7	13/64 5.2	1 5/32 29.4	25/32 19.8	1 1/2 38.1	1 19/32 40.5	2 21/32 67.5	3/8	1.3 .59

Metric dimensions for reference only.

Not all parts are available from stock. Please contact customer service for availability (800) 626-2120.

For more information on bearing capabilities outside of our standard offering, please contact Application Engineering (800) 626-2093.

Mounted Ball Bearings *Browning*[®]



- Duty:** Light
- Rolling Elements:** Ball
- Housing:** Stamped Steel Two Bolt Flange
- Self Alignment:** +/- 1.5 Degrees
- Lock:** Setscrew
- Seal:** Contact
- Temperature:** -20° to 200°F
- Relube:** No

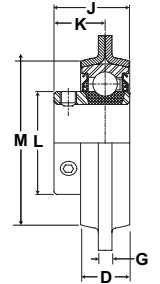
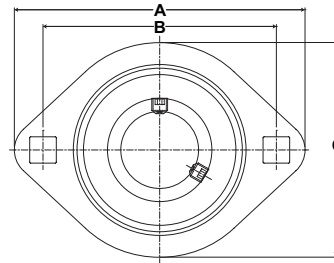

SSF2S 100 Series Light Duty Stamped Steel Two Bolt Flanges - Setscrew Locking

Bore Diameter inch	Max Radial Load lb/N	Part No.	Bearing Insert No.	Dimensions inch / mm									Bolt Size	Unit Wt. lb/kg
				A	B	C	D	G	J	L	K	M		
1/2	600	SSF2S-108	LS-108	3 3/16	2 1/2	2 1/4	9/16	5/32	15/16	31/32	5/8	1 47/64	1/4	.6
5/8	2669	SSF2S-110	LS-110	81.0	63.5	57.2	14.3	4.0	23.8	24.6	15.9	44.1		.27
3/4	600	SSF2S-112	LS-112	3 9/16	2 13/16	2 5/8	21/32	11/64	1 1/16	1 3/16	23/32	2 1/64	5/16	.8
	2669			90.5	71.4	66.7	16.7	4.3	27.0	30.2	18.3	51.2		.36
7/8	800	SSF2S-114	LS-114	3 3/4	3	2 13/16	21/32	11/64	1 7/64	1 3/8	49/64	2 7/32	5/16	.9
15/16	3558	SSF2S-115	LS-115	95.3	76.2	71.4	71.4	4.3	28.2	34.9	19.4	56.4		.41
1		SSF2S-116	LS-116											
1 1/8	1100	SSF2S-118	LS-118	4 7/16	3 9/16	3 5/16	3/4	13/64	1 5/32	1 19/32	25/32	2 21/32	3/8	1.0
1 3/16	4893	SSF2S-119	LS-119	112.7	90.5	84.1	19.1	5.2	29.4	40.5	19.8	67.5		.45
1 1/4		SSF2S-120S	LS-120S											

Browning[®] Mounted Ball Bearings



- Duty:** Light
- Rolling Elements:** Ball
- Housing:** Cylindrical O.D.
Rubber Grommet
- Lock:** Setscrew
- Seal:** Contact
- Temperature:** -20° to 200°F
- Relube:** No

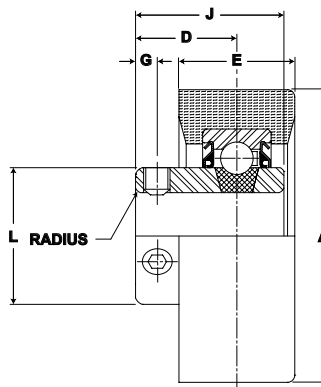

RUBRS 100 Series Light Duty Rubber Grommets - Setscrew Locking

Bore Diameter inch	Steady Radial Load lb/N	Part No.	Bearing Insert No.	Dimensions inch / mm						Unit Wt. lb/kg
				A	D	E	G	J	L	
1/2	250 1112	RUBRS-108	SLRS-108							.5 .23
5/8		RUBRS-110	SLRS-110	2 17/32 64.3	7/8 22.2	1 25.4	3/16 4.8	1 9/32 32.5	1 3/16 30.2	
3/4		RUBRS-112	SLRS-112							
15/16	300 1334	RUBRS-115	SLRS-115	2 17/32 64.3	7/8 22.2	1 25.4	3/16 4.8	1 3/8 34.9	1 3/8 34.9	.6 .27
1		RUBRS-116	SLRS-116							

Metric dimensions for reference only.

Not all parts are available from stock. Please contact customer service for availability (800) 626-2120.

For more information on bearing capabilities outside of our standard offering, please contact Application Engineering (800) 626-2093.



Duty: Light
Rolling Elements: Ball
Housing: Cylindrical O.D. Rubber Grommet
Lock: BOA Concentric
Seal: Contact
Temperature: -20° to 200°F
Relube: No

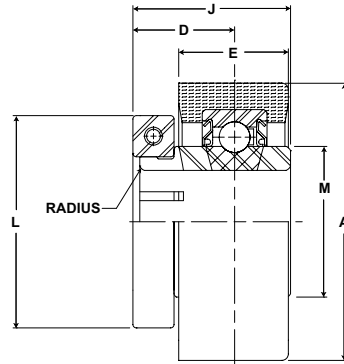

RUBRB 100 Series Light Duty Rubber Grommets - BOA Concentric Locking

Bore Diameter inch	Steady Radial Load lb/N	Part No.	Bearing Insert No.	Dimensions inch / mm						Torx Cap Screw	Unit Wt. lb/kg	Collar No.
				A	D	E	J	L	M			
5/8	250	RUBRB-112	SLRB-112	2 17/32	7/8	1	11/32	1 3/4	1 3/16	T-25	.5 .23	B-12B
	1112			64.3	22.2	25.4	99.1	44.5	30.2			
1	300	RUBRB-116	SLRB-116	2 17/32	15/16	1	1 7/16	1 15/16	1 3/8	T-25	.6 .27	B-15A
	1334			64.3	23.8	25.4	36.5	49.2	34.9			



Duty: Light
Rolling Elements: Ball
Housing: Cylindrical O.D. Rubber Grommet
Lock: Eccentric
Seal: Contact
Temperature: -20° to 200°F
Relube: No

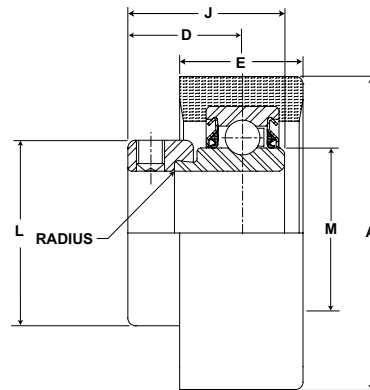

RUBRE 100 Series Light Duty Rubber Grommets - Eccentric Locking

Bore Diameter inch	Steady Radial Load lb/N	Part No.	Bearing Insert No.	Dimensions inch / mm						Setscrew Tap	Unit Wt. lb/kg
				A	D	E	J	L	M		
3/4	250	RUBRE-112	SLE-112	2 17/32	59/64	1	1 17/64	1 5/16	1 3/16	1/4-28	.5 .23
	1112			64.3	23.4	25.4	32.1	.60	.54		
15/16	300	RUBRE-115	SLE-115	2 17/32	59/64	1	1 17/64	1 1/2	1 3/8	1/4-28	.6 .27
	1334	RUBRE-116	SLE-116	64.3	23.4	25.4	32.1	.68	.62		

Replacement collar part numbers can be found on page G-214.

Browning® Mounted Ball Bearings



Duty: Light
Rolling Elements: Ball
Outer: Cylindrical O.D.
Self Alignment: +/- 1.5 Degrees
Lock: Setscrew
Seal: Contact
Temperature: -20° to 200°F
Relube: No

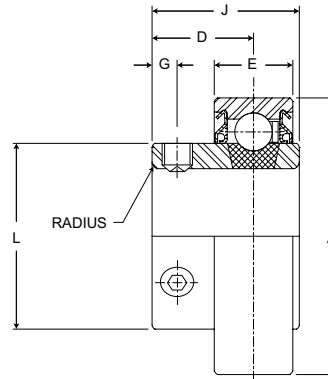

SLS 100 Series Light Duty Straight OD Inserts - Setscrew Locking

Bore Diameter inch	Part No.	Basic Dynamic Rating lb/N	Dimensions inch / mm						Max. Rad. To Clear	Setscrew Thread	Unit Wt. lb/kg
			A	D	E	G	J	L			
1/2	SLS-108	2108	1.5748	5/8	33/64	5/32	15/16	31/32	.055	10-32	.4
5/8	SLS-110	9377	40	15.9	13.1	4.0	23.8	24.6	1.4		.18
3/4	SLS-112	2611 11614	1.8504 47	23/32 18.3	19/32 15.1	3/16 4.8	1 1/16 27.0	1 3/16 30.2	0.07 1.8	1/4-28	.5 .23
7/8	SLS-114	2801	2.042	49/64	19/32	3/16	1 7/64	1 3/8	0.07	1/4-28	.6
15/16	SLS-115	12459	52	19.4	15.1	4.8	28.2	34.9	1.8		.27
1	SLS-116										
1 1/8	SLS-118	4381	2.4409	25/32	45/64	7/32	1 5/32	1 19/32	0.08	1/4-28	1.0
1 3/16	SLS-119	19487	62	19.8	17.9	5.6	29.4	40.5	2.0		.45
1 1/4	SLS-120S										
1 1/4	SLS-120	5782	2.8346	55/64	3/4	1/4	1 9/32	1 55/64	0.08	5/16-24	1.6
1 3/8	SLS-122	25718	72	21.8	19.1	6.4	32.5	47.2	2.0		.73
1 7/16	SLS-123										
1 1/2	SLS-124	7340 32648	3.1496 80	15/16 23.8	55/64 21.8	9/32 7.1	1 27/64 36.1	2 1/16 52.4	0.095 2.4	5/16-24	1.8 .82

Outside diameter may be oversized due to seal press fit.

Metric dimensions for reference only.

Not all parts are available from stock. Please contact customer service for availability (800) 626-2120.

For more information on bearing capabilities outside of our standard offering, please contact Application Engineering (800) 626-2093.

Mounted Ball Bearings *Browning*



Duty: Light
Rolling Elements: Ball
Outer: Spherical O.D.
Lock: Setscrew
Seal: Contact
Temperature: -20° to 200°F
Relube: No

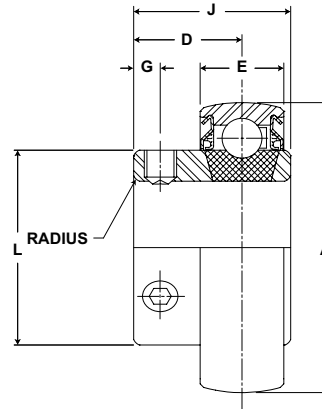

LS 100 Series Light Duty Inserts - Setscrew Locking

Bore Diameter inch	Part No.	Basic Dynamic Rating lb/N	Dimensions inch / mm						Max. Rad. To Clear	Setscrew Thread	Unit Wt. lb/kg
			A	D	E	G	J	L			
1/2	LS-108	2108	1.5748	5/8	33/64	5/32	15/16	31/32	.055	10-32	.4
5/8	LS-110	9377	40	15.9	13.1	4.0	23.8	24.6	1.4		.18
3/4	LS-112	2611 11614	1.8504 47	23/32 18.3	19/32 15.1	3/16 4.8	1 1/16 27.0	1 3/16 30.2	.070 1.8	1/4-28	.5 .23
7/8	LS-114	2801 12459	2.0472 52	49/64 19.4	19/32 15.1	3/16 4.8	1 7/64 28.2	1 3/8 34.9	.070 1.8	1/4-28	.6 .27
15/16	LS-115										
1	LS-116										
1 1/8	LS-118	4381 19487	2.4409 62	25/32 19.8	45/64 17.9	7/32 5.6	1 5/32 29.4	1 19/32 40.5	.080 2.0	1/4-28	1.0 .45
1 3/16	LS-119										
1 1/4	LS-120S										
1 1/4	LS-120	5782 25718	2.8346 72	55/64 21.8	3/4 19.1	1/4 6.4	1 9/32 32.5	1 55/64 47.2	.080 2.0	5/16-24	1.6 .73
1 3/8	LS-122										
1 7/16	LS-123										
1 1/2	LS-124	7340 32648	3.1496 80	15/16 23.8	55/64 21.8	9/32 7.1	1 27/64 36.1	2 1/16 52.4	.095 2.4	5/16-24	1.8 .82
1 11/16	LS-127	7901 35144	3.3465 85	61/64 24.2	55/64 21.8	5/16 7.9	1 7/16 36.5	2 19/64 58.3	.110 2.8	5-16-24	1.4 .64
1 3/4	LS-128										
1 15/16	LS-131	7889 35090	3.5433 90	1 3/64 26.6	29/32 23.0	3/8 9.5	1 35/64 39.3	2 15/32 62.7	.110 2.8	3/8-24	1.6 .73

Browning® Mounted Ball Bearings



Duty: Light
Rolling Elements: Ball
Outer: Spherical O.D.
Lock: Setscrew
Seal: Contact
Temperature: -20° to 200°F
Relube: No

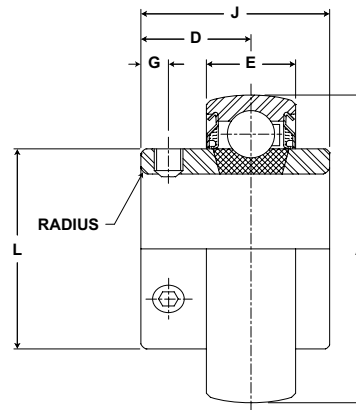

LRS 100 Series Light Duty Inserts - Setscrew Locking

Bore Diameter inch	Part No.	Basic Dynamic Rating lb/N	Dimensions In Inches						Max. Rad. To Clear	Setscrew Thread	Unit Wt. lb/kg
			A	D	E	G	J	L			
3/4	LRS-112	2611 11614	47MM 1.8504	13/16 20.6	19/32 15.1	3/16 4.8	1 7/32 31.0	1 3/16 30.2	.04 1.0	1/4-28	.4 .18
7/8	LRS-114	2801 12459	52MM 2.0472	55/64 21.8	19/32 15.1	7/32 5.6	1 3/8 34.9	1 3/8 34.9	.04 1.0	1/4-28	.5 .23
15/16	LRS-115										
1	LRS-116										
1 1/8	LRS-118	4381 19487	62MM 2.4409	7/8 22.2	45/64 17.9	7/32 5.6	1 1/2 38.1	1 19/32 40.5	.04 1.0	1/4-28	.9 .41
1 3/16	LRS-119										
1 1/4	LRS-120S										

Metric dimensions for reference only.

Not all parts are available from stock. Please contact customer service for availability (800) 626-2120.

For more information on bearing capabilities outside of our standard offering, please contact Application Engineering (800) 626-2093.

Mounted Ball Bearings *Browning*



Duty: Intermediate
Rolling Elements: Ball
Outer: Spherical O.D.
Lock: Setscrew
Seal: Contact
Temperature: -20° to 200°F

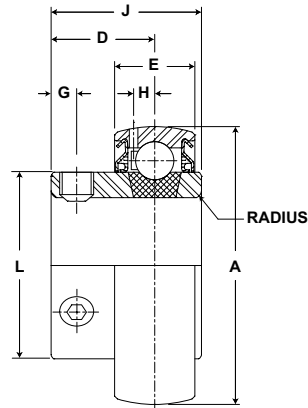

VS 100 Series Intermediate Duty Inserts - Setscrew Locking

Bore Diameter inch	Part No.	Basic Dynamic Rating lb/N	Dimensions In Inches							Max. Rad. To Clear	Setscrew Thread	Unit Wt. lb/kg
			A	D	E	G	H	J	L			
1/2	VS-108	2108	1.5748	5/8	.512	5/32	9/64	15/16	31/32	.055	10-32	.3
5/8	VS-110	9377	40	15.9	13	4.0	3.6	23.8	24.6	1.4		.14
3/4	VS-112	2611 11614	1.8504 47	23/32 18.3	.591 15	3/16 4.8	5/32 4.0	1 1/16 27.0	1 3/16 30.2	.070 1.8	1/4-28	.4 .18
7/8	VS-114	2801 12459	2.0472 52	49/64 19.4	.591 15	3/16 4.8	5/32 4.0	1 7/64 28.2	1 3/8 34.9	.070 1.8	1/4-28	.5 .23
15/16	VS-115											
1	VS-116											
1 1/8	VS-118	4381 19487	2.4409 62	25/32 19.8	.709 18	7/32 5.6	13/64 5.2	1 5/32 29.4	1 19/32 40.5	.080 2.0	1/4-28	.7 .32
1 3/16	VS-119											
1 1/4	VS-120S											
1 1/4	VS-120	5782 25718	2.8346 72	55/64 21.8	.748 19	1/4 6.4	15/64 6.0	1 9/32 32.5	1 55/64 47.2	.080 2.0	5/16-24	1.0 .45
1 3/8	VS-122											
1 7/16	VS-123											
1 1/2	VS-124	7340 32648	3.1496 80	15/16 23.8	.866 22	9/32 7.1	17/64 6.7	1 27/64 36.1	2 1/16 52.4	.095 2.4	5/16-24	1.2 .54
1 11/16	VS-127	7901 35144	3.3465 85	61/64 24.2	.866 22	5/16 7.9	17/64 6.7	1 7/16 36.5	2 19/64 58.3	.110 2.8	5/16-24	1.4 .64
1 3/4	VS-128											
1 15/16	VS-131	7889 35090	3.5433 90	1 3/64 26.6	.906 23	3/8 9.5	9/32 7.1	1 35/64 39.3	2 15/32 62.7	.110 2.8	3/8-24	1.6 .73
2	VS-132S											
2	VS-132	9752 43377	3.9370 100	1 7/64 28.2	.984 25	3/8 9.5	5/16 7.9	1 21/32 42.1	2 23/32 69.1	.125 3.2	3/8-24	2.2 1.00
2 3/16	VS-135											

Browning® Mounted Ball Bearings



Duty: Intermediate
Rolling Elements: Ball
Outer: Spherical O.D.
Lock: Eccentric
Seal: Contact
Temperature: -20° to 200°F

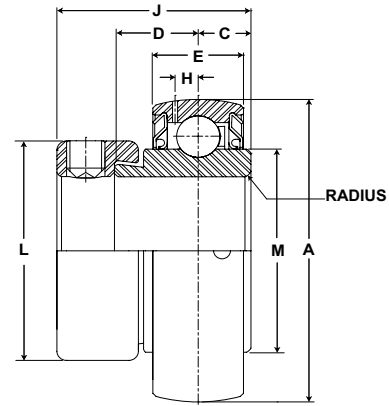

VE 100 Series Intermediate Duty Inserts - Eccentric Locking

Bore Diameter inch	Part No.	Basic Dynamic Rating lb/N	Dimensions inch / mm								Max. Rad. To Clear	Setscrew Thread	Unit Wt. lb/kg
			A	C	D	E	H	J	L	M			
1/2	VE-108	2108	1.5748	5/16	1/2	.512	9/64	1 3/16	1 3/16	31/32	.055	1/4-28	.4
5/8	VE-110	9377	40	7.9	12.7	13	3.6	30.2	30.2	24.6	1.4		.18
3/4	VE-112	2611 11614	1.8504 47	11/32 8.7	35/64 13.9	.591 15	5/32 4.0	1 17/64 32.1	1 5/16 33.3	1 3/16 30.2	.070 1.8	1/4-28	.4 .18
7/8	VE-114	2801	2.0472	11/32	35/64	.591	5/32	1 17/64	1 1/2	1 3/8	.070	1/4-28	.5
15/16	VE-115	12459	52	8.7	13.9	15	4.0	32.1	38.1	34.9	1.8		.23
1	VE-116												
1 1/8	VE-118	4381	2.4409	3/8	37/64	.709	13/64	1 27/64	1 3/4	1 19/32	.080	5/16-24	.7
1 3/16	VE-119	19487	62	9.5	14.7	18	5.2	36.1	44.5	40.5	2.0		.32
1 1/4	VE-120S												
1 1/4	VE-120	5782	2.8346	27/64	5/8	.748	15/64	1 37/64	2 3/16	1 55/64	.080	3/8-24	1.1
1 3/8	VE-122	25718	72	10.7	15.9	19	6.0	40.1	55.6	47.2	2.0		.50
1 7/16	VE-123												
1 1/2	VE-124	7340 32648	3.1496 80	31/64 12.3	3/4 19.1	.866 22	17/64 6.7	1 49/64 44.8	2 3/8 60.3	2 1/16 52.4	.095 2.4	3/8-24	1.4 .64
1 11/16	VE-127	7901	3.3465	31/64	3/4	.866	17/64	1 49/64	2 1/2	2 19/64	.110	3/8-24	1.6
1 3/4	VE-128	35144	85	12.3	19.1	22	6.7	44.8	63.5	58.3	2.8		.73
1 15/16	VE-131	7889	3.5433	1/2	3/4	.906	9/32	1 25/32	2 3/4	2 15/32	.110	3/8-24	1.8
2	VE-132S	35090	90	12.7	19.1	23	7.1	45.2	69.9	62.7	2.8		.82
2	VE-132	9752	3.937	35/64	13/16	.984	5/16	1 63/64	3	2 23/32	.125	7/16-20	2.5
2 3/16	VE-135	43377	100	13.9	20.6	25	7.9	50.4	76.2	69.1	3.2		1.13

Replacement collar part numbers can be found on page G-214.

Metric dimensions for reference only.

Not all parts are available from stock. Please contact customer service for availability (800) 626-2120.

For more information on bearing capabilities outside of our standard offering, please contact Application Engineering (800) 626-2093.

Mounted Ball Bearings *Browning*



Duty: Standard
Rolling Elements: Ball
Outer: Spherical O.D.
Lock: Setscrew
Seal: Contact and Flinger
Temperature: -20° to 200°F

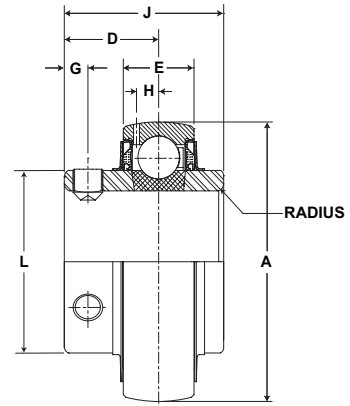

VS 200 Series Standard Duty Inserts - Setscrew Locking - Inch

Bore Diameter inch	Part No.	Basic Dynamic Rating lb/N	Dimensions inch / mm							Max. Rad. To Clear	Setscrew Thread	Unit Wt. lb/kg
			A	D	E	G	H	J	L			
1/2	VS-208	2108	1.5748	5/8	.512	5/32	9/64	1 1/32	31/32	.040	10-32	.4
5/8	VS-210	9377	40	15.9	13	4.0	3.6	26.2	24.6	1.0		.18
3/4	VS-212	2611 11614	1.8504 47	23/32 18.3	.591 15	3/16 4.8	5/32 4.0	1 7/32 31.0	1 3/16 30.2	.040 1.0	1/4-28	.4 .18
7/8	VS-214	2801	2.0472	13/16	.591	7/32	5/32	1 3/8	1 3/8	.040	1/4-28	.6
15/16	VS-215	12459	52	20.6	15	5.6	4.0	34.9	34.9	1.0		.27
1	VS-216											
1 1/8	VS-218	4381	2.4409	7/8	39/55	7/32	13/64	1 1/2	1 19/32	.040	1/4-28	.9
1 3/16	VS-219	19487	62	22.2	18	5.6	5.2	38.1	40.5	1.0		.41
1 1/4	VS-220S											
1 1/4	VS-220	5782	2.8346	1	.748	1/4	15/64	1 11/16	1 55/64	.040	5/16-24	1.2
1 3/8	VS-222	25718	72	25.4	19	6.4	6.0	42.9	47.2	1.0		.54
1 7/16	VS-223											
1 1/2	VS-224	7340 32648	3.1496 80	1 3/16 30.2	.866 22	5/16 7.9	17/64 6.7	1 15/16 49.2	2 1/16 52.4	.062 1.6	5/16-24	1.5 .68
1 5/8	VS-226	7901	3.3465	1 3/16	.866	5/16	17/64	1 15/16	2 19/64	.062	5/16-24	1.6
1 11/16	VS-227	35144	85	30.2	22	7.9	6.7	49.2	58.3	1.6		.73
1 3/4	VS-228											
1 15/16	VS-231	7889	3.5433	1 9/32	.906	3/8	9/32	2 1/32	2 15/32	.062	3/8-24	1.8
2	VS-232S	35090	90	32.5	23	9.5	7.1	51.6	62.7	1.6		.82
2	VS-232	9752	3.9370	1 5/16	.984	3/8	5/16	2 3/16	2 23/32	.080	3/8-24	2.3
2 3/16	VS-235	43377	100	33.3	25	9.5	7.9	55.6	69.1	2.0		1.04
2 1/4	VS-236	11789	4.3307	1 9/16	1.063	7/16	11/32	2 9/16	2 63/64	.080	3/8-24	3.1
2 7/16	VS-239	52437	110	39.7	27	11.1	8.7	65.1	75.8	2.0		1.41

Browning® Mounted Ball Bearings



Duty: Standard
Rolling Elements: Ball
Outer: Spherical O.D.
Lock: Setscrew
Seal: Contact and Flinger
Temperature: -20° to 200°F

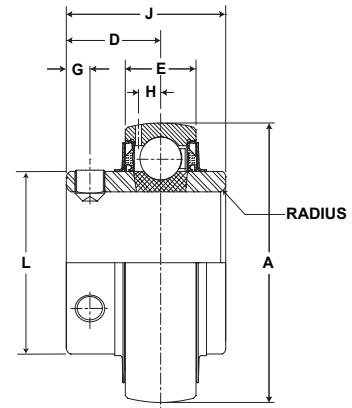

VS 200 Series Standard Duty Inserts - Setscrew Locking - Metric

Bore Diameter mm	Part No.	Basic Dynamic Rating N/lb	Dimensions mm / inch							Max. Rad. To Clear	Setscrew Thread	Unit Wt. kg/lb
			A	D	E	G	H	J	L			
20	VS-20MM	11614 2611	47.000 1.8504	18.3 23/32	15.0 .591	4.8 3/16	4.0 5/32	31.0 1 7/32	30.2 1 3/16	1.0 .040	M6	.18 .4
25	VS-25MM	12459 2801	52.000 2.0472	20.6 13/16	15.0 .591	5.6 7/32	4.0 5/32	34.9 1 3/8	34.9 1 3/8	1.0 .040	M6	.27 .6
30	VS-30MM	19487 4381	62.000 2.4409	22.2 7/8	18.0 .709	5.6 7/32	5.2 13/64	38.1 1 1/2	40.5 1 19/32	1.0 .040	M6	.41 .9
35	VS-35MM	25718 5782	72.000 2.8346	25.4 1	19.0 .748	6.4 1/4	6.0 15/64	42.9 1 11/16	47.2 1 55/64	1.0 .040	M8	.54 1.2
40	VS-40MM	32648 7340	80.000 3.1496	30.2 1 3/16	22.0 .866	7.9 5/16	6.7 17/64	49.2 1 15/16	52.4 2 1/16	1.6 .062	M8	.68 1.5
45	VS-45MM	35144 7901	85.000 3.3465	30.2 1 3/16	22.0 .866	7.9 5/16	6.7 17/64	49.2 1 15/16	58.3 2 19/64	1.6 .062	M8	.73 1.6
50	VS-50MM	35090 7889	90.000 3.5433	32.5 1 9/32	23.0 .906	9.5 3/8	7.1 9/32	51.6 2 1/32	62.7 2 15/32	1.6 .062	M10	.82 1.8
55	VS-55MM	43377 9752	100.000 3.9370	33.3 1 5/16	25.0 .984	9.5 3/8	7.9 5/16	55.6 2 3/16	69.1 2 23/32	2.0 .080	M10	1.04 2.3
60	VS-60MM	52437 11789	110.000 4.3307	39.7 1 9/16	27.0 1.063	11.1 7/16	8.7 11/32	65.1 2 9/16	75.8 2 63/64	2.0 .080	M10	1.41 3.1

Metric dimensions for reference only.

Not all parts are available from stock. Please contact customer service for availability (800) 626-2120.

For more information on bearing capabilities outside of our standard offering, please contact Application Engineering (800) 626-2093.

Mounted Ball Bearings *Browning*



- Duty:** Standard
- Rolling Elements:** Ball
- Outer:** Spherical O.D.
- Self Alignment:** +/- 1.5 Degrees
- Lock:** BOA Concentric
- Seal:** Contact and Flinger
- Temperature:** -20° to 200°F

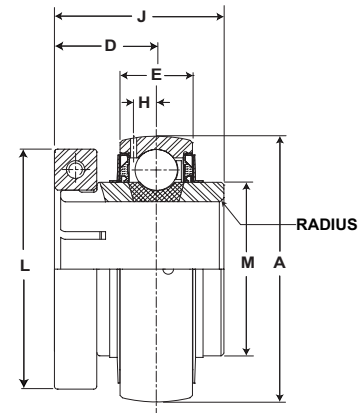

VB 200 Series Standard Duty Inserts - BOA Concentric Locking

Bore Diameter inch	Part No.	Basic Dynamic Rating lb/N	Dimensions inch / mm							Max. Rad. To Clear	Torx Cap Screw	Unit Wt. lb/kg	Collar No.
			A	D	E	H	J	L	M				
3/4	VB-212	2611 11614	1.8504 47	25/32 19.8	.594 15	5/32 4.0	1 9/32 32.5	1 3/4 44.5	1 3/16 30.2	0.04 1.0	T-25	0.5 .23	B-12A
7/8	VB-214	2801 12459	2.0472 52	7/8 22.2	.594 15	5/32 4.0	1 7/16 36.5	1 15/16 49.2	1 3/8 34.9	0.04 1.0	T-25	0.8 .36	B-15A
15/16	VB-215												
1	VB-216												
1 1/8	VB-218	4381 19487	2.4409 62	15/16 23.8	.709 18	13/64 5.2	1 9/16 39.7	2 3/16 55.6	1 19/32 40.5	0.04 1.0	T-25	1.1 .50	B-19A
1 3/16	VB-219												
1 1/4	VB-220S												
1 1/4	VB-220	5782 25718	2.8346 72	1 1/16 27.0	.750 19	15/64 6.0	1 3/4 44.5	2 7/16 61.9	1 55/64 47.2	0.04 1.0	T-27	1.5 .68	B-23A
1 3/8	VB-222	5782 25718	2.8346 72	1 1/16 27.0	.750 19	15/64 6.0	1 3/4 44.5	2 9/16 65.1	1 55/64 47.2	0.04 1.0	T-27	1.5 .68	B-23B
1 7/16	VB-223												
1 1/2	VB-224	7340 32648	3.1496 80	1 1/4 31.8	.875 22	17/64 6.7	2 50.8	2 11/16 68.3	2 1/16 52.4	0.062 1.6	T-27	1.8 .82	B-25A
1 5/8	VB-226	7901 35144	3.3465 85	1 1/4 31.8	.875 22	17/64 6.7	2 50.8	2 13/16 71.4	2 19/64 58.3	0.062 1.6	T-27	1.9 .86	B-27A
1 11/16	VB-227	7901 35144	3.3465 85	1 1/4 31.8	.875 22	17/64 6.7	2 50.8	2 15/16 74.6	2 19/64 58.3	0.062 1.6	T-27	1.9 .86	B-27B
1 3/4	VB-228												
1 15/16	VB-231	7889 35090	3.5433 90	1 11/32 34.1	.906 23	9/32 7.1	2 3/32 53.2	3 3/8 85.7	2 15/32 62.7	0.062 1.6	T-30	2.4 1.09	B-31B
2	VB-232S												
2	VB-232	9752 43377	3.9370 100	1 3/8 34.9	.984 25	5/16 7.9	2 1/4 57.2	3 1/2 88.9	2 23/32 69.1	0.08 2.0	T-30	2.9 1.32	B-35A
2 3/16	VB-235	9752 43377	3.9370 100	1 3/8 34.9	.984 25	5/16 7.9	2 1/4 57.2	3 5/8 92.1	2 23/32 69.1	0.08 2.0	T-30	2.9 1.32	B-35B
2 1/4	VB-236	11789 52437	4.3307 110	1 5/8 41.3	1.063 27	11/32 8.7	2 5/8 66.7	4 1/16 103.2	2 63/64 75.8	0.08 2.0	T-45	4.3 1.95	B-39A
2 7/16	VB-239	11789 52437	4.3307 110	1 5/8 41.3	1.063 27	11/32 8.7	2 5/8 66.7	4 1/8 104.8	2 63/64 75.8	0.08 2.0	T-45	4.3 1.95	B-39B



Duty: Standard
Rolling Elements: Ball
Outer: Spherical O.D.
Lock: Eccentric
Seal: Contact and Flinger
Temperature: -20° to 200°F

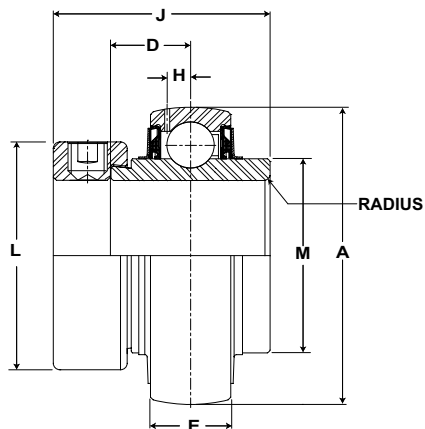

VE 200 Series Standard Duty Inserts - Eccentric Locking

Bore Diameter inch	Part No.	Basic Dynamic Rating lb/N	Dimensions inch / mm							Max. Rad. To Clear	Setscrew Tap	Unit Wt. lb/kg
			A	D	E	H	J	L	M			
1/2	VE-208	2108	1.5748	35/64	.512	9/64	1 15/32	1 3/16	31/32	.055	1/4-28	.6
5/8	VE-210	9377	40	13.9	13	3.6	37.3	30.2	24.6	1.4	1/4-28	.27
3/4	VE-212	2611 11614	1.8504 47	43/64 17.1	.591 15	5/32 4.0	1 23/32 43.7	1 5/16 33.3	1 3/16 30.2	.070 1.8	1/4-28	.6 .27
7/8	VE-214	2801	2.0472	11/16	.591	5/32	1 3/4	1 1/2	1 3/8	.070	1/4-28	.8
15/16	VE-215	12459	52	17.5	15	4.0	44.5	38.1	34.9	1.8	1/4-28	.36
1 1/8	VE-218	4381	2.4409	23/32	.709	13/64	1 29/32	1 3/4	1 19/32	.080	5/16-24	1.1
1 3/16	VE-219	19487	62	18.3	18	5.2	48.4	44.5	40.5	2.0	5/16-24	.50
1 1/4	VE-220S											
1 1/4	VE-220	5782	2.8346	3/4	.748	15/64	2 1/64	2 3/16	1 55/64	.080	3/8-24	1.4
1 3/8	VE-222	25718	72	19.1	19	6.0	51.2	55.6	47.2	2.0	3/8-24	.64
1 7/16	VE-223											
1 1/2	VE-224	7340 32648	3.1496 80	27/32 21.4	.866 22	17/64 6.7	2 7/32 56.4	2 3/8 60.3	2 1/16 52.4	.095 2.4	3/8-24	1.7 .77
1 5/8	VE-226	7901	3.3465	27/32	.866	17/64	2 7/32	2 1/2	2 19/64	.110	3/8-24	1.8
1 11/16	VE-227	35144	85	21.4	22	6.7	56.4	63.5	58.3	2.8	3/8-24	.82
1 3/4	VE-228											
1 15/16	VE-231	7889 35090	3.5433 90	31/32 24.6	.906 23	9/32 7.1	2 15/32 62.7	2 3/4 69.9	2 15/32 62.7	.110 2.8	3/8-24	2.3 1.04
2	VE-232	9752	3.9370	1 3/32	.984	5/16	2 13/16	3	2 23/32	.125	7/16-20	3
2 3/16	VE-235	43377	100	27.8	25	7.9	71.4	76.2	69.1	3.2	7/16-20	1.36
2 1/4	VE-236	11789	4.3307	1 7/32	1.063	11/32	3 1/16	3 3/8	2 63/64	.125	7/16-20	4
2 7/16	VE-239	52437	110	31.0	27	8.7	77.8	85.7	75.8	3.2	7/16-20	1.81

Replacement collar part numbers can be found on page G-214.

Metric dimensions for reference only.

Not all parts are available from stock. Please contact customer service for availability (800) 626-2120.

For more information on bearing capabilities outside of our standard offering, please contact Application Engineering (800) 626-2093.

Mounted Ball Bearings *Browning*



Duty: Medium
Rolling Elements: Ball
Outer: Spherical O.D.
Lock: Setscrew
Seal: Contact and Flinger
Temperature: -20° to 200°F

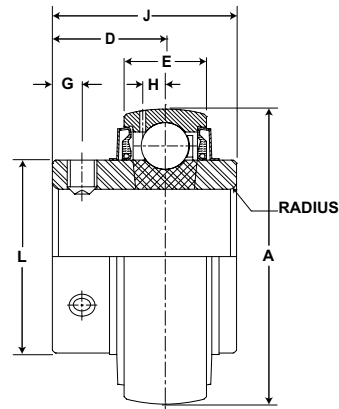

VS 300 Series Medium Duty Inserts - Setscrew Locking

Bore Diameter inch	Part No.	Basic Dynamic Rating lb/N	Dimensions inch / mm							Max. Rad. To Clear	Setscrew Tap	Unit Wt. lb/kg
			A	D	E	G	H	J	L			
1	VS-316	4381 19487	2.4409 62	7/8 22.2	.709 18.0	7/32 5.6	13/64 5.2	1 1/2 38.1	1 19/32 40.5	.040 1.0	1/4-28	.9 .41
1 3/16	VS-319	5782 25718	2.8346 72	1 25.4	.748 19.0	1/4 6.4	15/64 6.0	1 11/16 42.9	1 55/64 47.2	.040 1.0	5/16-24	1.2 .54
1 7/16	VS-323	7340 32648	3.1496 80	1 3/16 30.2	.866 22.0	5/16 7.9	17/64 6.7	1 15/16 49.2	2 1/16 52.4	.062 1.6	5/16-24	1.6 .73
1 1/2	VS-324	7901 35144	3.3465 85	1 3/16 30.2	.866 22.0	5/16 7.9	17/64 6.7	1 15/16 49.2	2 19/64 58.3	.062 1.6	5/16-24	1.6 .73
1 11/16	VS-327	7889	3.5433	1 9/32	.906	3/8	9/32	2 1/32	2 15/32	.062	3/8-24	1.8
1 3/4	VS-328	35090	90	32.5	23.0	9.5	7.1	51.6	62.7	1.6		.82
1 15/16	VS-331	9752 43377	3.9370 100	1 5/16 33.3	.984 25.0	3/8 9.5	5/16 7.9	2 3/16 55.6	2 23/32 69.1	.080 2.0	3/8-24	2.3 1.04
2 3/16	VS-335	11789 52437	4.3307 110	1 9/16 39.7	1.063 27.0	7/16 11.1	21/64 8.3	2 9/16 65.1	2 63/64 75.8	.080 2.0	3/8-24	3.1 1.41



Duty: Standard
Rolling Elements: Ball
Outer: Spherical O.D.
Lock: BOA Concentric
Seal: Contact and Flinger
Temperature: -20° to 200°F

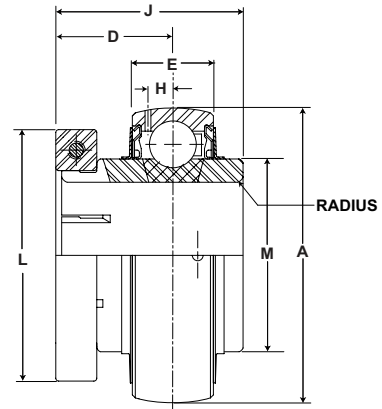

VB 300 Series Medium Duty Inserts - BOA Concentric Locking

Bore Diameter inch	Part No.	Basic Dynamic Rating lb/N	Dimensions inch / mm							Max. Rad. To Clear	Furx Cap Screw	Unit Wt. lb/kg	Collar No.
			A	D	E	G	H	J	L				
1	VB-316	4381 19487	2.4409 62	7/8 22.2	.709 18.0	7/32 5.6	13/64 5.2	1 9/16 39.7	2 1/16 52.4	.040 1.0	T-25	.9 .41	B-19A
1 3/16	VB-319	5782 25718	2.8346 72	1 25.4	.748 19.0	1/4 6.4	15/64 6.0	1 3/4 44.5	2 7/16 61.9	.040 1.0	T-27	1.2 .54	B-23A
1 7/16	VB-323	7340 32648	3.1496 80	1 3/16 30.2	.866 22.0	5/16 7.9	17/64 6.7	2 50.8	2 11/16 68.3	.062 1.6	T-27	1.6 .73	B-25A
1 1/2	VB-324	7901 35144	3.3465 85	1 3/16 30.2	.866 22.0	5/16 7.9	17/64 6.7	2 50.8	2 13/16 71.4	.062 1.6	T-27	1.6 .73	B-27A
1 11/16	VB-327	7889	3.5433	1 9/32	.906	3/8	9/32	3	3 1/4	.062	T-30	1.8	B-31A
1 3/4	VB-328	35090	90	32.5	23.0	9.5	7.1	76.2	82.6	1.6		.82	
1 15/16	VB-331	9752 43377	3.9370 100	1 5/16 33.3	.984 25.0	3/8 9.5	5/16 7.9	2 1/4 57.2	3 1/2 88.9	.080 2.0	T-30	2.3 1.04	B-35A
2 3/16	VB-335	11789 52437	4.3307 110	1 9/16 39.7	1.063 27.0	7/16 11.1	11/32 8.7	2 5/8 66.7	4 1/16 103.2	.080 2.0	T-45	3.1 1.41	B-39A

Metric dimensions for reference only.

Not all parts are available from stock. Please contact customer service for availability (800) 626-2120.

For more information on bearing capabilities outside of our standard offering, please contact Application Engineering (800) 626-2093.



VE Bearing Insert - Eccentric Locking Collars Replacement Table

Bore Diameter	Series				Collar No.
	VE-100	VE-200	SLE-100	RUBRE-100	
1/2	VE-108	VE-208	SLE-108	-	ELC-08
5/8	VE-110	VE-210	SLE-110	-	ELC-10
3/4	VE-112	VE-212	SLE-112	RUBRE-112	ELC-12
7/8	VE-114	VE-214	SLE-114	-	ELC-14
15/16	VE-115	VE-215	SLE-115	RUBRE-115	ELC-15
1	VE-116	VE-216	SLE-116	RUBRE-116	ELC-16
1 1/8	VE-118	VE-218	SLE-118	-	ELC-18
1 3/16	VE-119	VE-219	SLE-119	-	ELC-19
1 1/4S	VE-120S	VE-220S	SLE-120S	-	ELC-20S
1 1/4	VE-120	VE-220	SLE-120	-	ELC-20
1 3/8	VE-122	VE-222	SLE-122	-	ELC-22
1 7/16	VE-123	VE-223	SLE-123	-	ELC-23
1 1/2	VE-124	VE-224	SLE-124	-	ELC-24
1 5/8	-	VE-226	-	-	ELC-26
1 11/16	VE-127	VE-227	-	-	ELC-27
1 3/4	VE-128	VE-228	-	-	ELC-28
1 15/16	VE-131	VE-231	-	-	ELC-31
2S	VE-132S	-	-	-	ELC-32S
2	VE-132	VE-232	-	-	ELC-32
2 3/16	VE-135	VE-235	-	-	ELC-35
2 1/4	-	VE-236	-	-	ELC-36
2 7/16	-	VE-239	-	-	ELC-39

Browning VER Style Ball Bearings

Browning VER bearings feature black oxide treated inner and outer rings, and extended inner race bearing with ball riding nylon retainer. Shaft lock is achieved by 120° spaced diamond faceted setscrew locking. The contact seal, with black oxide treated flinger provides a good balance between contaminant resistance, grease loss and friction.

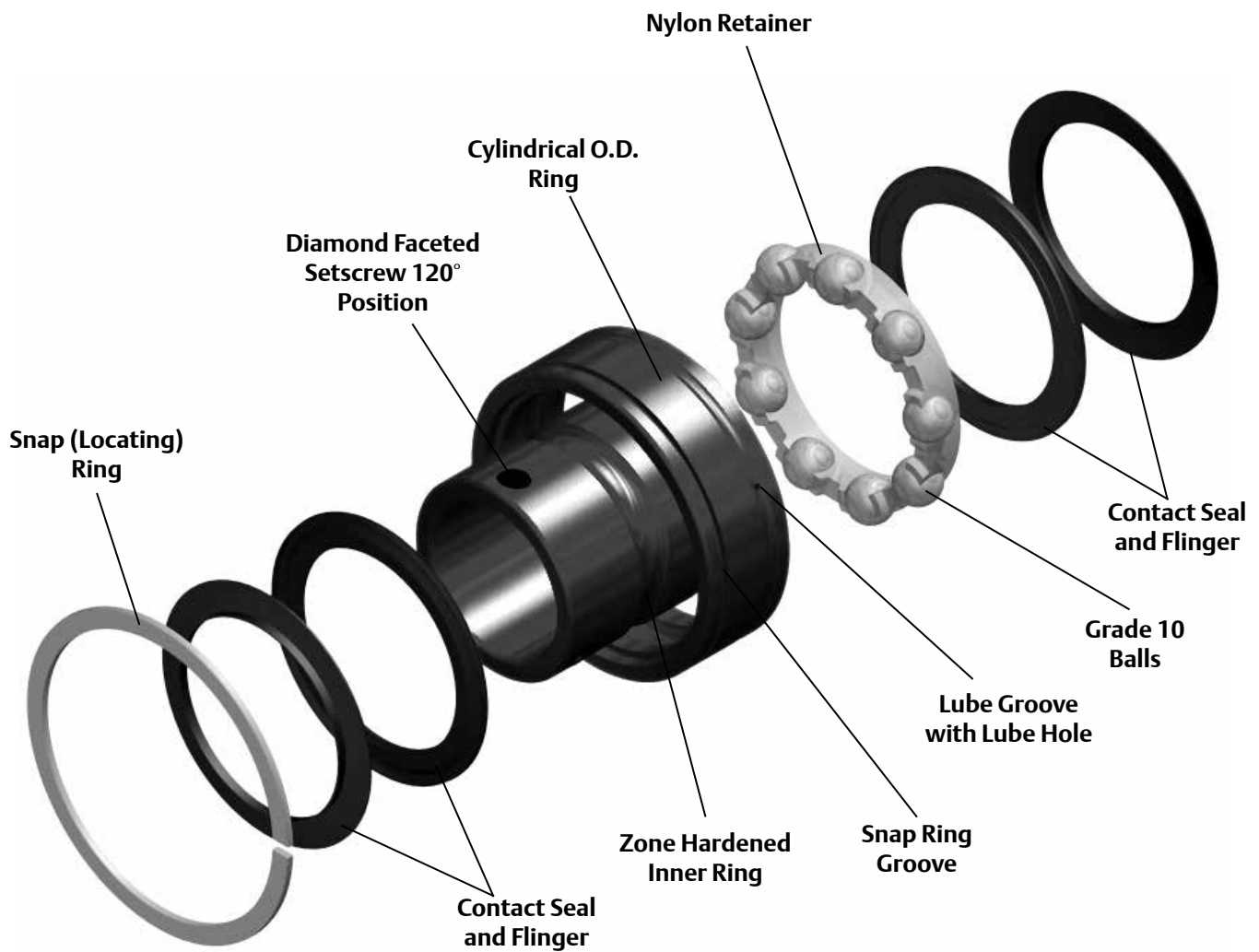



Browning VER Style Ball Nomenclature

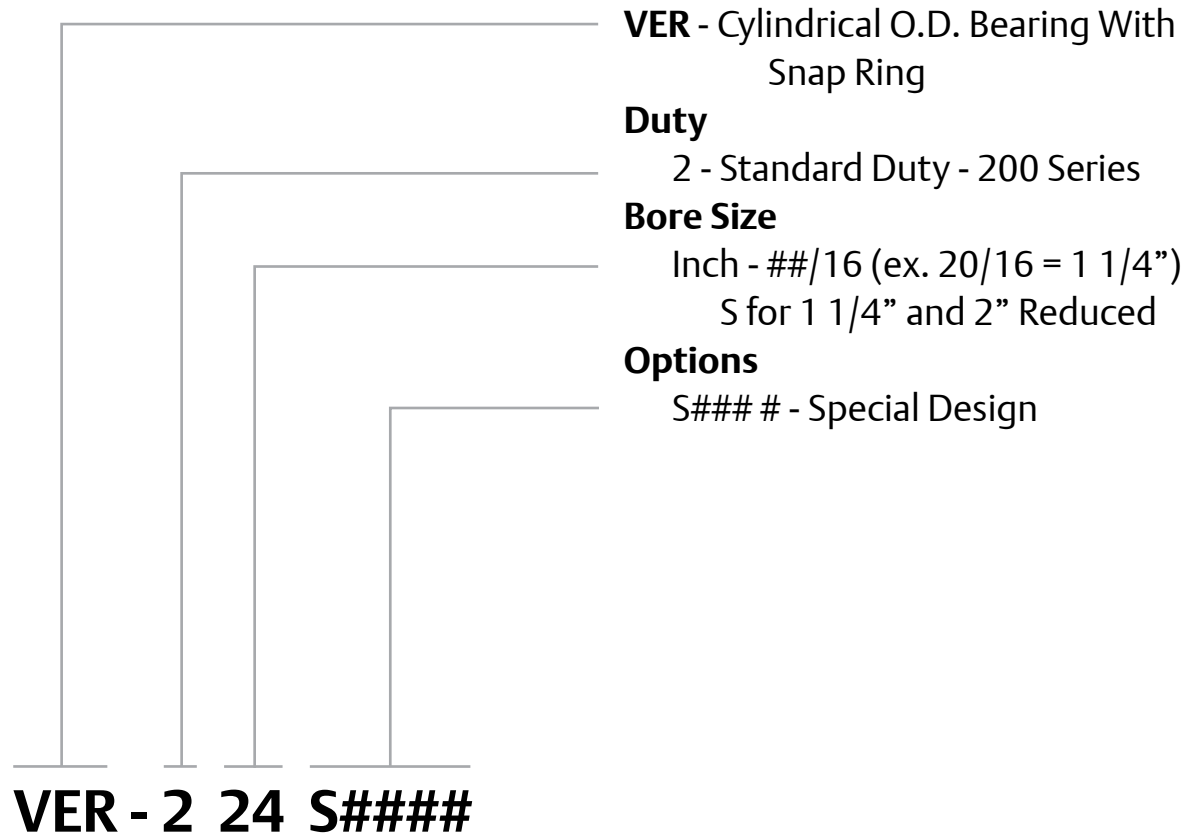

Browning® Cylindrical OD Insert Bearings



Features and Benefits

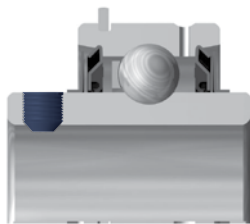

Setscrew Locking

120° spaced, balanced three point contact minimizes inner ring distortion vibration, reduces noise, and improves reliability. Precision manufactured diamond faceted setscrews contribute to improved clamping and resistance to back out.



Sealing

Positive contact molded nitrile rubber contact seal with an auxiliary flinger element standard. The contact seal allows grease purge and helps keep contamination out of the bearing while the flinger provides a rotating shield that directs contamination away from the seal.



Zone Hardened Inner Race

Browning incorporates a unique heat treat process that hardens the inner race only where it is needed...under the ball path. The zone hardened inner race results in improved lock reliability as a result of less distortion at setscrew location and improved thread conformity resulting in improved clamping and resistance to setscrew back-out.

Identification Marking

Browning VER bearings have the part number laser marked on the inner ring for easy verification of the part number during installation and for replacement.

Cylindrical OD Insert Bearings *Browning*



- Duty:** Standard
- Rolling Elements:** Ball
- Outer:** Cylindrical O.D. Outer
- Lock:** Setscrew
- Seal:** Contact Seal and Flinger
- Temperature:** -20° to 200°F
- Relube:** Through Groove In O.D.

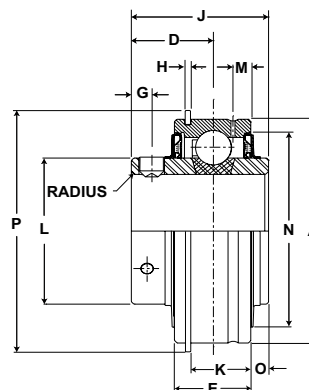

VER 200 Series Standard Duty Cylindrical O.D. Inserts - Setscrew Locking

Bore Diameter inch	Part No.	Basic Dynamic Rating lb/N	Dimensions inch / mm											Max. Rad. To Clear	Unit Wt. lb/kg	
			A	D	G	E	H	J	K	L	N	O	P			
1/2	VER-208	2611 11614	1.8504	23/32	11/64	5/8	3/64	1 7/32	31/64	1 3/16	1 19/32	3/16	2 1/16	.040	.6	
5/8	VER-210		47	18.3	4.4	15.9	1.2	31.0	12.3	30.2	40.5	4.8	52.4	1.02	.27	
3/4	VER-212															
7/8	VER-214	2801 12459	2.0472	13/16	13/64	3/4	3/64	1 3/8	39/64	1 3/8	1 53/64	3/16	2 17/64	.040	.7	
15/16	VER-215		52	20.6	5.2	19.1	1.2	34.9	15.5	34.9	46.4	4.8	57.5	1.02	.32	
1	VER-216															
1 1/16	VER-217	4381 19487	2.4409	7/8	7/32	7/8	1/16	1 1/2	11/16	1 19/32	2 3/32	3/16	2 21/32	.040	.9	
1 1/8	VER-218		62	22.2	5.6	22.2	1.6	38.1	17.5	40.5	53.2	4.8	67.5	1.02	.41	
1 3/16	VER-219															
1 1/4	VER-220S															
1 1/4	VER-220	5782 25718	2.8346	1	7/32	15/16	1/16	1 11/16	3/4	55/64	2 7/16	7/32	3 5/64	.040	1.4	
1 3/8	VER-222		72	25.4	5.6	23.8	1.6	42.9	19.1	21.8	61.9	5.6	78.2	1.02	.64	
1 7/16	VER-223															
1 1/2	VER-224	7340 32648	3.1496	1 3/16	1/4	1 3/32	1/16	1 15/16	29/32	2 1/16	2 47/64	13/64	3	.062	2	
1 9/16	VER-225		80	30.2	6.4	27.8	1.6	49.2	23.0	52.4	69.5	5.2	86.5	1.57	.91	
1 5/8	VER-226	7901 35144	3.3465	1 3/16	1/4	1 3/32	1/16	1 15/16	29/32	2 19/64	3	13/64	3 19/32	.062	2.3	
1 11/16	VER-227		85	30.2	6.4	27.8	1.6	49.2	23.0	58.3	76.2	5.2	91.3	1.57	1.04	
1 3/4	VER-228															
1 15/16	VER-231	7889 35090	3.5433	1 9/32	19/64	1 1/8	3/32	2 1/32	29/32	2 15/32	3 5/32	3/16	3 25/32	.062	2.4	
			90	32.5	7.5	28.6	2.4	51.6	23.0	62.7	80.2	4.8	96.0	1.57	1.09	
2	VER-232	9752 43377	3.9370	1 5/16	19/64	1 3/16	3/32	2 3/16	31/32	2 23/32	3 15/32	9/32	4 3/16	.080	3	
2 3/16	VER-235		100	33.3	7.5	30.2	2.4	55.6	24.6	69.1	88.1	7.1	106.4	2.03	1.36	
2 1/4	VER-236	11789 52437	4.3307	1 9/16	19/64	1 1/4	3/32	2 9/16	1 1/32	2 63/64	3 13/16	3/8	4 19/32	.080	4	
2 3/8	VER-238		110	39.7	7.5	31.8	2.4	65.1	26.2	75.8	96.8	9.5	116.7	2.03	1.81	
2 7/16	VER-239															

Outside diameter may be oversized due to seal press fit.
Metric dimensions for reference only.



Mounted Ball Bearing Engineering see page G-220.

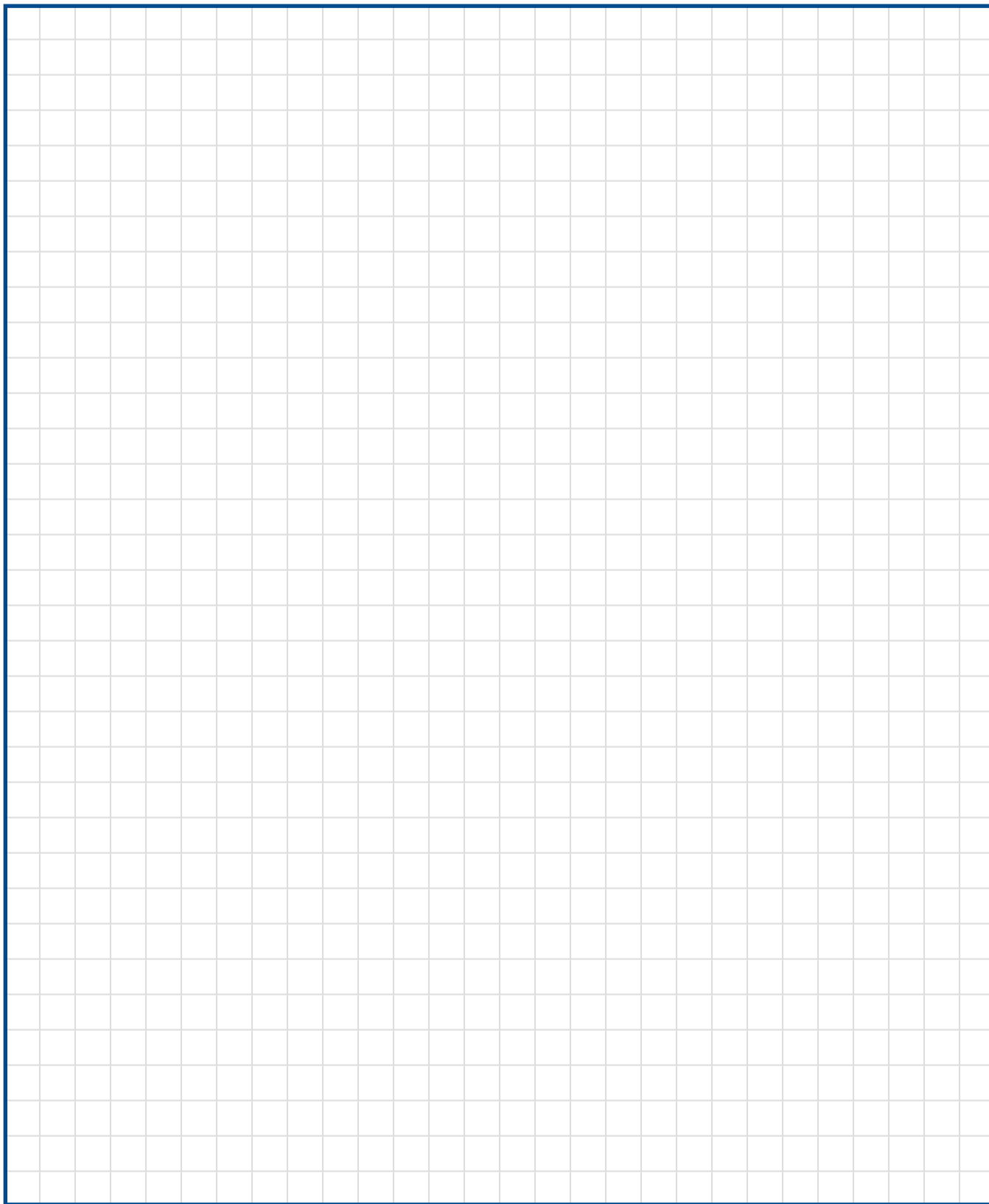

For more information on bearing capabilities outside of our standard offering, please contact Application Engineering (800) 626-2093.



Table of Contents

Load Ratings and Life G-221

- Table 1 - Life Adjustment Factor for Reliability
- Table 2 - Shock / Vibration Factors
- Table 3 - Equivalent Load Calculation Data - Ball Bearing
- Table 4 - Sealmaster Ball Bearing Load Ratings
- Table 5 - Browning Ball Bearing Load Ratings

Load and Speed G-230

- Table 6 - Sealmaster Ball Bearing Load / Speed Chart
- Table 7 - Browning Ball Bearing 200 & 300 Series Load / Speed Chart
- Table 8 - Browning Ball Bearing 100 Series Load / Speed Chart

Speed Rating (Limit) Tables..... G-235

- Table 9 - Sealmaster Gold Standard Duty Maximum Speed Rating
- Table 10 - Sealmaster Gold Medium Duty Maximum Speed Rating
- Table 11 - Sealmaster Material Handling Maximum Speed Rating
- Table 12 - Browning 100 and 200 Series Maximum Speed Rating
- Table 13 - Browning 300 Series Maximum Speed Rating

Locking Types G-244

Installation and Lubrication G-246

- Sealmaster Gold
 - Mounting Housed Units (G-246)
 - Mounting Sealmaster Gold Cylindrical O.D. Inserts and Cylindrical O.D. Housings (G-248)
 - Replacing Existing Sealmaster Gold Inserts (G-250)
- Material Handling
 - Mounting Housed Units (G-251)
 - Replacing Existing Sealmaster MH Inserts (G-253)
- Sealmaster Gold and Material Handling Bearing Lubrication (G-254)
- Browning Mounted Ball Bearing Installation and Relubrication
 - Mounting Housed Units (G-255)
 - Mounting Cylindrical O.D. (VER) Inserts (G-256)
 - Replacing Existing Browning Inserts (G-256)
 - Browning Mounted Ball Lubrication (G-257)

Cylindrical OD Housing Fit Guidelines G-259

- Table 14 - ER, VER and Cylindrical OD Insert Bearing Housing/Roll Bore (G-259)
- Table 15 - Sealmaster SC and MSC Housing Bore (G-261)

Vibration Analysis..... G-263

- Table 16 – Vibration and Geometry Information

Load Ratings and Life

Life Calculations

The L10 (rating) life for any given application and bearing selection can be calculated in terms of millions of revolutions by using the bearing Basic Dynamic Rating and applied radial load (or, equivalent radial load in the case of radial bearing applications having combined radial and thrust loads). The L10 life for any given application can be calculated in terms of hours, using the bearing Basic Dynamic Rating, applied load (or equivalent radial load) and suitable speed factors, by the following equation:

$$L_{10} = \left(\frac{C}{P}\right)^3 \times \frac{1,000,000}{60 \times n} = \left(\frac{C}{P}\right)^3 \times \frac{16667}{n}$$

Where:

L_{10} = The # of hours that 90% of identical bearings under ideal conditions will operate at a specific speed and condition before fatigue is expected to occur.

C = Basic Dynamic Rating (lbs)
1,000,000 Revolutions

P = Constant Equivalent Radial Load (lbs)

n = Speed (RPM)

Additionally, the ABMA provides application factors for all types of bearings which need to be considered to determine an adjusted Rated Life (L_{na}). L10 life rating is based on laboratory conditions yet other factors are encountered in actual bearing application that will reduce bearing life. L_{na} life rating takes into account reliability factors, material type, and operating conditions.

$$L_{na} = a_1 \times a_2 \times a_3 \times L_{10}$$

Where:

L_{na} = Adjusted Rated Life.

a_1 = Reliability Factor. Adjustment factor applied where estimated fatigue life is based on reliability other than 90% (See Table 1).

Table 1 Life Adjustment Factor for Reliability

Reliability %	L_{na}	a_1
90	L10	1
95	L5	0.62
96	L4	0.53
97	L3	0.44
98	L2	0.33
99	L1	0.21
50	L50	5

a_2 = Material Factor. Life adjustment for bearing race material. Power Transmission Solutions bearing races are manufactured from bearing quality steel. Therefore the a_2 factor is 1.0.

a_3 = Life Adjustment Factor for Operating Conditions. This factor should take into account the adequacy of lubricant, presence of foreign matter, conditions causing changes in material properties, and unusual loading or mounting conditions. Assuming a properly selected and mounted bearing having adequate seals and lubricant operating below 250°F and tight fitted to the shaft, the a_3 factor should be 1.0.

Mounted bearings are typically “slip fitted” to the shaft and rely on design features such as the inner race length and locking device for support. ABMA recommends an a_3 factor of .456 for “slip fit” ball bearings. See sample calculations on page G-224.

Vibration and shock loading can act as an additional loading to the steady expected applied load. When shock or vibration is present, an a_3 Life Adjustment Factor can be applied. Shock loading has many variables which often are not easily determined. When shock or vibration is present, the following a_3 Life Adjustment Factors are recommended. The shock factor is used in combination with the “slip fit” factor.

The a_3 factor takes into account a wide range of application and mounting conditions as well as bearing features and design. Accurate determination of this factor is normally achieved through testing and in-field experience. Power Transmission Solutions offers a wide range of options which can maximize bearing performance. Consult Application Engineering for more information. See sample calculations on page G-224.

Table 2 Shock/Vibration Factor

Type	a_3 Factor
Steady Loading	1.0
Light Shock/Vibration	.5
Moderate Shock/Vibration	.3



Load Ratings and Life Continued

Combined Load - Ball Bearings

For applications where a combination of both radial and thrust loads are applied to the bearing the equivalent radial load must be calculated and applied to the L10 life formula.

1. Use Table 3 (below) and Table 4 (page G-228) to identify the relative axial load factor (ND2).
2. Determine the relative axial load (RAL):

$$RAL = \frac{F_a}{ND^2} \text{ - applied thrust load}$$

ND² - relative axial load factor

3. Match the nearest relative axial load value in Table 3 to the corresponding “e” value. For precise calculation, linearly interpolate the values for “e” for your exact relative axial load value.

Table 3 Equivalent Load Calculation Data - Ball Bearings

Relative Axial Load	e	Fa / Fr ≤ e		Fa / Fr > e	
		x	y	x	y
24.92	0.19	1	0	0.56	2.30
50.03	0.22				1.99
99.91	0.26				1.71
149.35	0.28				1.55
200.10	0.30				1.45
300.15	0.34				1.31
500.25	0.38				1.15
749.65	0.42				1.04
999.05	0.44				1.00

4. Calculate Fa/Fr and compare value to the “e” value found in step #3 above.
5. Choose values for “X” and “Y” based on step #3 & 4 and from Table 3. Linear interpolation is recommended for exact calculations.
6. Calculate equivalent radial load using the following equation:

$$P = XFr + YFa$$
7. Calculate the adjusted life (Lna) using the life calculation formula above.

Variable Load Formula

Root mean load (RML) is to be used when a number of varying loads are applied to a bearing for varying time limits. Maximum loading still must be considered for bearing size selection.

$$RML^* = \sqrt[3]{\frac{(L_1^3 N_1) + (L_2^3 N_2) + (L_3^3 N_3)}{100}}$$

Where:

RML = Root Mean Load (lbs.)

L₁, L₂, etc. = Load in pounds

N₁, N₂, etc. = Percent of total time operated at loads L₁, L₂, etc.

*Apply RML to rating at mean speed to determine resultant life.

Mean Speed Formula

The following formula is to be used when operating speed varies over time.

$$Mean\ Speed = \frac{S_1 N_1 + S_2 N_2 + S_3 N_3}{100}$$

S₁S₂, etc = Speeds in RPM

N₁N₂, etc = Percentage of total time operated at speeds S₁S₂, etc

High Load Applications

Applications where the loading approaches the load listed in the rating tables on pages G-230 to G-233 at 5000 hours life and 150/250 RPM, should be reviewed and given special consideration.

Modifications to consider Include:

- Shafting size should be closely controlled for a line to line to a light press fit.
- Skwezloc® Locking Collar or double lock is the preferred lock.
- Lubricants with “EP” extreme pressure additives may be required.
- Care in housing selection, load direction, and mounting techniques should be exercise

Load Ratings and Life Continued

High Speed Applications

Applications where the speed is in the range of 80-100% of the maximum speeds listed in the rating tables on pages G-230 to G-233, should be reviewed and given special consideration.

Modifications to consider include:

- Shaft size should be controlled to specifications listed in the installation section. See tables above.
- SKWEZLOC Locking Collar and double lock are the preferred lock systems for high speed applications.
- High quality lubricants should be used.
- Grease should be added more frequently and in small amounts. See Page G-254.
- Care in mounting techniques should be exercised. See Page G-246 to G-253.

Bearing Life In Oscillating Applications

The equivalent rotative speed (ERS) is used in life calculations when the bearing does not make complete revolutions during operation. The ERS is then used as the bearing operating speed in the calculation of the L10 (Rating) Life. The formula is based on sufficient angular rotation to have roller paths overlap.

ERS = Equivalent Rotative Speed

N = Total number of degrees per minute through which the bearing will rotate.

$$ERS = \frac{N}{360}$$

In the above formula, allowance is made for the total number of stress applications on the weakest race per unit time, which, in turn, determines fatigue life and the speed factors. The theory behind fretting corrosion is best explained by the fact that the rolling elements in small angles of oscillation retrace a path over an unchanging area of the inner or outer races where the lubricant is prevented by inertia from flowing in behind the roller as the bearing oscillates in one direction. Upon reversal, this small area of rolling contact is traversed by the same roller in the dry state. The friction of the two unlubricated surfaces causes fretting corrosion and produces failures which are unpredictable from a normal life standpoint.

With a given bearing selected for an oscillating application, the best lubrication means is a light mineral oil under positive flow conditions. With a light oil, there is a tendency for all areas in the bearing load zone to be immersed in lubricant at all times. The full flow lubrication dictates that any oxidized material which may form is immediately carried away by the lubricant, and since these oxides are abrasive, further wear tends to be avoided. If grease lubrication must be used, it is best to consult with either the bearing manufacturer or the lubricant manufacturer to determine the best possible type of lubricant. Greases have been compounded to resist the detrimental effect of fretting corrosion for such applications.

Static Load Rating

The “static load rating” for rolling element bearings is that uniformly distributed static radial load acting on a non-rotating bearing, which produces a contact stress of 580,000 psi at the center of the most heavily loaded rolling element. At this stress level, plastic deformation begins to be significant. Experience has shown that the plastic deformation at this stress level can be tolerated in most bearing applications without impairment of subsequent bearing operation. In certain applications where subsequent rotation of the bearing is slow and where smoothness and friction requirements are not too exacting, a higher static load limit can be tolerated. Where extreme smoothness is required or friction requirements are critical, a lower static load limit may be necessary.

Minimum Bearing Load

Skidding, or sliding, of the rolling elements on the raceway instead of a true rolling motion can cause excessive wear. Applications with high speeds and light loading are particularly prone to skidding. As a general guideline, rolling element bearings should be radially loaded at least 1% of Basic Dynamic Rating for ball bearings. For applications where load is light relative to the bearings dynamic load rating, consult Application Engineering for assistance.



Load Ratings and Life Continued

Computing Bearing Loads

In the computation of bearing loads in any application of an Power Transmission Solutions unit, the principal factor determining the selection of the unit is the equivalent radial load to which the bearing will be subjected. These radial loads result from any one or any combination of the following sources:

1. Weights of machine parts supported by bearings.
2. Tension due to belt or chain pull.
3. Centrifugal force from out of balance, eccentric or cam action.

The resulting load from any one, or any combination of the above sources is further determined by knowing:

1. The magnitude of the load.
2. Direction of the load.
3. The point of load application.
4. The distance between bearing centers.

Bearing loads are the result of force acting on the shaft. Direction, magnitude, and location with respect to the bearings must be considered when calculating bearing loads. The following cases are typical examples of loads encountered and methods of calculating bearing loads.

CASE #1
Drive Load Calculation

$$P = \frac{126,000 \times \text{HP}}{\text{RPM} \times d} \times K = \text{Apply } P \text{ to Case 2, 3 or 4 if applicable}$$

HP = horsepower
RPM = revolutions per minute
d = pitch of pulley in inches
K = constant for type of drive used
K = 1.5 for V-belts
K = 2 to 3 for flat transmission belts
K = 1.1 for chain drives

CASE #2
Cantilever and Drive

$$\text{Load on Bearing A} = \frac{P_1 \times (a + k) - (P_2 \times b)}{k}$$

$$= \frac{200 \times (4 + 9) - (80 \times 2)}{9}$$

$$= 271 \text{ lbs.}$$

$$\text{Load on Bearing B} = \frac{P_2 \times (k + b) - (P_1 \times a)}{k}$$

$$= \frac{80 \times (9 + 2) - (200 \times 4)}{9}$$

$$= 9 \text{ lbs.}$$

CASE #3
Straddle, Cantilever Drive

$$\text{Load on Bearing A} = \frac{P_1 \times (k + a) + (P_2 \times c) - (P_3 \times d)}{k}$$

$$= \frac{60 \times (12 + 2) + (180 \times 6) - (70 \times 4)}{12}$$

$$= 137 \text{ lbs.}$$

$$\text{Load on Bearing B} = \frac{-(P_1 \times a) + (P_2 \times b) + P_3 \times (k + d)}{k}$$

$$= \frac{-(60 \times 2) + (180 \times 6) + 70 \times (12 + 4)}{12}$$

$$= 173 \text{ lbs.}$$

CASE #4
Straddle Mount, Cantilever Drive

$$\text{Load on Bearing A} = \frac{(P_1 \times b) - (P_2 \times c)}{k}$$

$$= \frac{(1000 \times 4) - (150 \times 3)}{11}$$

$$= 323 \text{ lbs.}$$

$$\text{Load on Bearing B} = \frac{(P_1 \times a) + (c + k) \times (P_2)}{k}$$

$$= \frac{(1000 \times 7) + (3 + 11) \times (150)}{11}$$

$$= 827 \text{ lbs.}$$

CASE #5
Vibrating Drives

Load due to Centrifugal and Inertial Forces - In a shaker or gyrating screen bearing application, the load on the bearings is increased by sudden stopping, starting, and reversing of typically large loads. This can be expressed as a basic physical law:

Force = Mass x Accelerations

In order to use this law, we develop from it the following equation:

$$F = .000341 \times WR(\text{RPM})^2$$

Where: F = Load of force in lbs.
W = Weight of rotating mass in lbs.
R = Radius of rotation or throw in feet
RPM = Shaft rotation in revolutions per minute

What is the centrifugal bearing load on a shaker screen which weighs 2,500 lbs., has a throw of 1/4 in. and whose shaft speed is 500 RPM?

$$F = .000341 \times 2,500 \times \frac{.250}{12} \times (500)^2 = 4,440 \text{ lbs.}$$

Load Ratings and Life Continued

Mounted Ball Bearing Selection - New Applications:

Using variations of the life formulas and application information, it is possible to select bearings based on desired life, load applied, and shaft speed. **This method can only be applied where axial load is less than or equal to 1/2 the radial load.**

1. Determine required application hours (L_{na}).
2. Calculate L_{10} using adjustment factors:

$$L_{10} = \frac{L_a}{a_1 \times a_2 \times a_3}$$

3. Calculate Basic Dynamic Radial Rating (C_{req}).

$$C_{req} = P \times \left(\frac{L_{10} \times N}{16,667} \right)^{1/3}$$

P = Constant Equivalent Radial Load (lbs)
 N = Speed (RPM)

4. Use Table No. 4 and 5 on page G-227 to G-229, find a basic Dynamic Radial Rating Value greater than or equal to C_{req} calculated in step # 3.

5. Select any bearing from the row in step # 4 or larger. If C_{req} is greater than the largest Basic Dynamic Radial Rating Value of Table No. 4 or 5, go to the Mounted Roller Bearing Section H and I.

6. If Ball bearing is selected, proceed with housing, seal, and lock selection.

Typical operating temperature range for standard bearings is -20° to 200° F for Browning and -20°F to 220°F for Sealmaster Gold. For operating temperatures outside this range, contact Application Engineering. For Maximum speed information, see tables on pages G-235 and G-243

Application Examples:

Example #1 - Pure Radial Load

Question #1:

What is the adjusted bearing life (L_{na} hours) for an NP-39 Sealmaster Ball Bearing with no shock conditions and the following application criteria?

Design Load (P) = 1300 lbs.
 Speed (n) = 1000 RPM
 Shaft Size = 2 7/16 in.
 Operating Temp. = 125°F

Solution:

1. Begin with the L_{10} life formula:

$$L_{10} = (C/P)^3 \times \frac{16667}{n}$$

Look up the insert of an NP-39 on page G-31. From Table No. 4 on page G-228, the Basic Dynamic Radial Rating is 11,789 lbs.

$$L_{10} = \left(\frac{11789}{1300} \right)^3 \times \frac{16667}{1000} = 12,430 \text{ hours}$$

2. Apply the life adjustment factors:

$$\begin{aligned} L_{na} \text{ hours} &= L_{10} \times a_1 \times a_2 \times a_3 \\ L_{na} \text{ hours} &= 12,430 \times 1 \times 1 \times 0.456 \\ L_{na} \text{ hours} &= 5,700 \text{ hours} \end{aligned}$$



Load Ratings and Life Continued

Question #2:

What is the adjusted bearing life (L10 hours) for an NP-39 Sealmaster Ball Bearing with moderate shock conditions and the same applications criteria from above?

Solution:

1. From Table 2 on page G-221:

$$a_3 = 0.5 \times 0.456$$

2. Re-Apply the life adjustment factors to the previously calculated L₁₀ life:

$$\begin{aligned} L_{na} \text{ hours} &= L_{10} \times a_1 \times a_2 \times a_3 \\ L_{na} \text{ hours} &= 12,430 \times 1 \times 1 \times (0.5 \times 0.456) \\ L_{na} \text{ hours} &= 2,830 \text{ hours} \end{aligned}$$

Example #2 - Combined Radial and Thrust Load

Question #1:

What is the adjusted bearing life (L_{na} hours) for an NP-39 Sealmaster Ball Bearing with no shock conditions and the following application criteria?

- Design Radial Load (F_r) = 500 lbs.
- Design Thrust Load (F_a) = 1000 lbs.
- Speed (n) = 1000 RPM
- Shaft Size = 2 7/16 in.
- Operating Temperature = 125°F

Solution:

1. Calculate F_a/F_r = 1000/500 = 2
2. Look up the insert of an NP-39 on page G-31. From Table 4 on page G-228, ND² is 3.969 lbs and Basic Dynamic Rating is 11,789 lbs.
3. Begin by calculating the Relative Axial Load (RAL):

$$RAL = \frac{F_a}{ND^2} = \frac{1000}{3.9690} = 251 \text{ lbs.}$$

4. From Table 3 on page G-222, interpolate RAL between 200.10 and 300.15 and “e” between 0.30 and 0.34 to obtain “e” value:

$$\frac{251 - 200.10}{300.15 - 200.10} = \frac{e - 0.30}{0.34 - 0.30}$$

Therefore e = .32

5. From Table 3 on page G-222, determine the value of “X” and “Y” through interpolation. Interpolate “e” between 0.30 and 0.34 and “Y” between 1.45 and 1.31 because F_a/F_r > e

$$\frac{0.32 - 0.30}{0.34 - 0.30} = \frac{Y - 1.45}{1.31 - 1.45}$$

Therefore Y = 1.38 and X = .56

6. Determine the equivalent radial load (P)

$$\begin{aligned} P &= (X F_r) + (Y F_a) \\ &= (0.56 \times 500) + (1.38 \times 1000) = 1660 \text{ lbs.} \\ L_{10} &= (C/P)^3 \times \frac{16667}{n} \end{aligned}$$

Look up the insert of an NP-39 on page G-31. From Table 4 on page G-228, the Basic Dynamic Rating is 11,789 lbs.

$$L_{na} = .456 \times \left(\frac{11789}{1660} \right)^3 \times \frac{16667}{1000} = 2722 \text{ hours}$$

Bearing Load Rating Tables

Table 4 - Sealmaster Ball Bearing Load Ratings

Series	Standard Duty, ER and Material Handling						Medium Duty			Basic Dynamic Rating		Basic Static Rating		Relative Axial Load Factor (ND ²)		Thrust Rating	
	Bore Diameter		Unit Size	Standard Duty	ER	Material Handling	Bore Diameter		Medium Duty	lb	N	lb	N	lb	N	lb	N
	inch	mm		Insert		Insert	inch	mm	Insert								
2-012	1/2	-	8	2-08	ER-8	-	-	-	-	2611	11614	1444	6423	.706	3.1	741	3296
	9/16	-	9	2-09	ER-9	-	-	-	-								
	5/8	-	10	2-010	ER-10	-	-	-	-								
	11/16	-	11	2-011	ER-11	-	-	-	-								
	3/4	-	12	2-012	ER-12	MH-12	-	-	-								
	-	20	204	5204	ER-204	MH-204	-	-	-								
2-015	13/16	-	13	2-013	ER-13	-	-	-	-	2801	12459	1651	7344	.784	3.5	490	2180
	7/8	-	14	2-014	ER-14	-	-	-	-								
	15/16	-	15	2-015	ER-15	-	-	-	-								
	-	25	205	5205	ER-205	MH-205	-	-	-								
	1	-	16	2-1	ER-16	MH-16	-	-	-								
2-13	1 1/16	-	17	2-11	ER-17	-	15/16	-	3-015	4381	19488	2567	11419	1.300	5.8	1177	5236
	1 1/8	-	18	2-12	ER-18	-	-	25	5305								
	-	30	206	5206	ER-206	MH-206	1	-	3-1								
	1 3/8	-	19	2-13	ER-19	MH-19	-	-	-								
	1 1/4	-	20R	1-14	ER-20R	MH-20R	-	-	-								
2-17	1 1/4	-	20	2-14	ER-20	MH-20	-	30	5306	5782	25719	3493	15538	1.742	7.8	1709	7602
	1 5/16	-	21	2-15	ER-21	-	1 3/16	-	3-13								
	1 3/8	-	22	2-16	ER-22	-	-	-	-								
	-	35	207	5207	ER-207	-	-	-	-								
	1 7/16	-	23	2-17	ER-23	MH-23	-	-	-								
2-19	1 1/2	-	24	2-18	ER-24	MH-24	-	35	5307	7340	32650	4467	19870	2.250	10.0	2254	10026
	1 9/16	-	25	2-19	ER-25	-	1 7/16	-	3-17								
	-	40	208	5208	ER-208	-	-	-	-								
2-111	1 5/8	-	26	2-110	ER-26	-	1 1/2	-	3-18	7901	35145	5139	22859	2.500	11.1	2350	10453
	1 11/16	-	27	2-111	ER-27	MH-27	-	40	5308								
	1 3/4	-	28	2-112	ER-28	-	-	-	-								
	-	45	209	5209	ER-209	-	-	-	-								
2-115	1 13/16	-	29	2-113	ER-29	-	1 11/16	-	3-111	7889	35092	5216	23202	2.500	11.1	2350	10453
	1 7/8	-	30	2-114	ER-30	-	1 3/4	-	3-112								
	1 15/16	-	31	2-115	ER-31	MH-31	-	45	5309								
	-	50	210	5210	ER-210	MH-210	-	-	-								
	2	-	32R	1-2	ER-32R	-	-	-	-								

Setscrew locking standard duty, ER cylindrical O.D., Material Handling and Medium Duty bearing are shown.

For Skwezloc and Double Setscrew Locking use the equivalent setscrew lock rating in the table. Example: 2-1, 2-1D and 2-1T all use the 2-015 series rating

For RB inserts use the equivalent ER series bearing listed to determine the capacity. Ex: RB-16, use ER-1



Table 4 - Sealmaster Ball Bearing Load Ratings continued

Series	Standard Duty, ER and Material Handling						Medium Duty			Basic Dynamic Rating		Basic Static Rating		Relative Axial Load Factor (ND ²)		Thrust Rating	
	Bore Diameter		Unit Size	Standard Duty	ER	Material Handling	Bore Diameter		Medium Duty	lb	N	lb	N	lb	N	lb	N
	inch	mm		Insert		Insert	inch	mm	Insert								
2-23	2	-	32	2-2	ER-32	MH-32	1 15/16	-	3-115	9752	43379	6601	29363	3.316	14.8	2886	12838
	2 1/8	-	34	2-22	ER-34	-	-	50	5310								
	-	55	211	5211	ER-211	-	-	-	-								
	2 3/16	-	35	2-23	ER-35	MH-35	-	-	-								
2-27	2 1/4	-	36	2-24	ER-36	-	-	55	5311	11789	52440	8150	36253	3.969	17.7	4105	18260
	-	60	212	5212	ER-212	-	2 3/16	-	3-23								
	2 3/8	-	38	2-26	ER-38	-	-	-	-								
	2 7/16	-	39	2-27	ER-39	MH-39	-	-	-								
2-211	2 1/2	-	40	-	ER-40	-	2 7/16	-	3-27	13971	62146	10063	44762	4.761	21.2	4503	20030
	2 11/16	-	43	2-211	ER-43	-	2 1/2	-	3-28								
	-	70	214	5214	ER-214	-	-	65	5313								
2-215	2 7/8	-	46	2-214	ER-46	-	2 11/16	-	3-211	14839	66007	11224	49927	5.237	23.3	5207	23162
	2 15/16	-	47	2-215	ER-47	-	-	70	5314								
	-	75	215	5215	ER-215	-	-	-	-								
2-33	3	-	48	-	ER-48	-	2 15/16	-	3-215	17412	77452	13174	58601	6.188	27.5	6032	26832
	-	80	216	5216	ER-216	-	-	75	5315								
	3 3/16	-	51	2-33	ER-51	-	3	-	3-3								
2-37	3 1/4	-	52	2-34	ER-52	-	-	80	5316	18681	83097	14496	64481	6.692	29.8	7474	33246
	3 3/8	-	54	2-36	ER-54	-	3 3/16	-	3-33								
	3 7/16	-	55	2-37	ER-55	-	-	-	-								
2-38	3 1/2	-	56	2-38	-	-	3 7/16	-	3-37	21566	95930	16301	72510	7.744	34.4	7839	34869
	-	90	218	5218	-	-	-	-	-								
2-43	3 15/16	-	63	-	ER-63	-	3 15/16	-	3-315	29905	133023	23553	104768	11.236	50.0	11097	49362
	-	100	-	-	-	-	-	100	5320								
	4	-	64	-	ER-64	-	4	-	3-4								
3-47	-	-	-	-	-	-	4 7/16	-	3-47	37482	166727	33267	147978	15.625	69.5	16697	74272
	-	-	-	-	-	-	4 15/16	-	3-415								

Setscrew locking standard duty, ER cylindrical O.D., Material Handling and Medium Duty bearing are shown.
 For Skwezloc and Double Setscrew Locking use the equivalent setscrew lock rating in the table. Example: 2-1, 2-1D and 2-1T all use the 2-015 series rating
 For RB inserts use the equivalent ER series bearing listed to determine the capacity. Ex: RB-16, use ER-16

Table 5 - Browning Ball Bearing Load Ratings

Series	100, 200 & VER		100 Series	200 Series	VER	300 Series		Basic Dynamic Rating		Basic Static Rating		Relative Axial Load Factor (ND ²)		Thrust Rating	
	Bore Diameter					Insert	Insert	Bore Diameter	Insert	lb	N	lb	N	lb	N
	inch	mm	inch	inch											
L-10	1/2	-	VS-108	VS-208	-	-	-	2108	9377	1117	4969	.563	2.5	320	1423
2-012		-	-	-	VER-208	-	-	2611	11614	1444	6423	.706	3.1	741	3296
L-10	5/8	-	VS-110	VS-210	-	-	-	2108	9377	1117	4969	.563	2.5	320	1423
2-012		-	-	-	VER-210	-	-	2611	11614	1444	6423	.706	3.1	741	3296
2-012	3/4	-	VS-112	VS-212	VER-212	-	-	2611	11614	1444	6423	.706	3.1	741	3296
	-	20	-	VS-20MM	-	-	-								
2-015	7/8	-	VS-114	VS-214	VER-214	-	-	2801	12459	1651	7344	.784	3.5	490	2180
	15/16	-	VS-115	VS-215	VER-215	-	-								
	-	25	-	VS-25MM	-	-	-								
	1	-	VS-116	VS-216	VER-216	-	-								
2-13	1 1/8	-	VS-118	VS-218	VER-217	1	VS-316	4381	19488	2567	11419	1.300	5.8	1177	5236
	-	30	-	VS-30MM	-										
	1 3/16	-	VS-119	VS-219	VER-219										
	1 1/4S	-	VS-120S	VS-220S	VER-220S										
2-17	1 1/4	-	VS-120	VS-220	VER-220	1 3/16	VS-319	5782	25719	3493	15538	1.742	7.8	1709	7602
	1 3/8	-	VS-122	VS-222	VER-222										
	-	35	-	VS-35MM	-										
	1 7/16	-	VS-123	VS-223	VER-223										
2-19	1 1/2	-	VS-124	VS-224	VER-224	1 7/16	VS-323	7340	32650	4467	19870	2.250	10.0	2254	10026
	1 9/16	-	-	-	VER-225										
	-	40	-	VS-40MM	-										
2-111	1 5/8	-	VS-126	VS-226	VER-226	1 1/2	VS-324	7901	35145	5139	22859	2.500	11.1	2350	10453
	1 11/16	-	VS-127	VS-227	VER-227										
	1 3/4	-	VS-128	VS-228	VER-228										
	-	45	VS-45MM	VS-45MM	-										
2-115	1 15/16	-	VS-131	VS-231	VER-231	1 11/16	VS-327	7889	35092	5216	23202	2.500	11.1	2350	10453
	-	50	-	VS-50MM	-										
	2S	-	VS-132S	VS-232S	-	1 3/4	VS-328								
2-23	2	-	VS-132	VS-232	VER-232	1 15/16	VS-331	9752	43379	6601	29363	3.316	14.8	2886	12838
	-	55	-	VS-55MM	-										
	2 3/16	-	VS-135	VS-235	VER-235										
2-27	2 1/4	-	-	VS-236	VER-236	2 3/16	VS-335	11789	52440	8150	36253	3.969	17.7	4105	18260
	-	60	-	VS-60MM	-										
	2 3/8	-	-	-	VER-238										
	2 7/16	-	-	VS-239	VER-239										

Setscrew locking 100, 200, 300 series and VER's shown.

For VE-100, RUBRE-100, RUBRS-100, SLS-100, LE-100, LR-100, LRS-100, LS-100 use equivalent ratings and factors for respective 100 series bore.

For VB-200, VE-200 equivalent ratings and factors for respective 200 series bore.

For VB-300 equivalent ratings and factors for respective 300 series bore.



Load and Speed

- Table 6 displays the Sealmaster Gold and Material Handling ball bearing load capacities for a given L10 life, speed and shaft size.
- Values in Table 6 represent radial loads at ideal conditions with press fit mounting to the shaft. ABMA recommends de-rating of slip fit mounted bearings. Elevated operating temperatures can reduce the load capacity of bearing steel where a material de-rating is also recommended.
 - For operating temperatures up to 200°F, divide the value in the load table by 1.3 to obtain the slip fit derated value.
 - For units designed for operating temperatures 200°F to 400°F, divide the value in the load table by 1.5 to obtain the slip fit/elevated temperature de-rate value.
 - Values in Table 6 represent equivalent radial loads only. For combined radial/thrust loads see page G-222.
- The gray shaded area indicates the maximum speed ratings for Skwezloc concentric locking collar and double setscrew lock bearings (applicable on sizes available). All speeds listed are for the standard felt seal. For speed ratings using alternate seals, see pages G-235 to G-240.
- The double line indicates the maximum speed ratings of material handling bearings.
- The blue shaded area represents maximum recommended load for given operating speed based on load of 25% BDR. It is NOT recommended to exceed these loads in general industrial applications. See note on page G-222 for high load applications.
- Areas designated by “-” exceed maximum value for standard bearings. See note on page G-223.
- Consult Application Engineering for load and speed applications not covered in this table.

Table 6 - Load/Speed Chart – Sealmaster Ball Bearings

Series	L10 Hours	Revolutions Per Minute																			
		50	150	500	1000	1250	1500	1750	2000	2500	3000	3500	4000	4500	5000	5500	6000	6500	7500	8000	10000
2-012	5000	652	652	491	390	362	341	324	310	287	270	257	246	236	228	221	215	209	199	195	181
	10000	652	583	390	310	287	270	257	246	228	215	204	195	188	181	175	170	166	158	155	144
	30000	583	404	270	215	199	188	178	170	158	149	141	135	130	126	122	118	115	110	107	100
	50000	491	341	228	181	168	158	150	144	133	126	119	114	110	106	103	100	97	92	91	84
	100000	390	270	181	144	133	126	119	114	106	100	95	91	87	84	81	79	77	73	72	67
2-015	5000	700	700	527	418	388	366	347	332	308	290	276	264	253	245	237	230	224	214	209	-
	10000	700	625	418	332	308	290	276	264	245	230	219	209	201	194	188	183	178	170	166	-
	30000	625	433	290	230	214	201	191	183	170	160	152	145	139	135	130	127	123	118	115	-
	50000	527	366	245	194	180	170	161	154	143	135	128	122	118	114	110	107	104	99	97	-
	100000	418	290	194	154	143	135	128	122	114	107	102	97	93	90	87	85	83	79	77	-
2-13	5000	1,095	1,095	825	654	608	572	543	519	482	454	431	412	396	383	371	360	351	334	327	-
	10000	1,095	978	654	519	482	454	431	412	383	360	342	327	315	304	294	286	278	265	260	-
	30000	978	678	454	360	334	315	299	286	265	250	237	227	218	211	204	198	193	184	180	-
	50000	825	572	383	304	282	265	252	241	224	211	200	191	184	178	172	167	163	155	152	-
	100000	654	454	304	241	224	211	200	191	178	167	159	152	146	141	137	133	129	123	121	-
2-17	5000	1,446	1,446	1,088	864	802	755	717	686	636	599	569	544	523	505	489	475	463	-	-	-
	10000	1,446	1,290	864	686	636	599	569	544	505	475	452	432	415	401	388	377	367	-	-	-
	30000	1,290	895	599	475	441	415	394	377	350	330	313	299	288	278	269	262	255	-	-	-
	50000	1,088	755	505	401	372	350	333	318	295	278	264	253	243	234	227	221	215	-	-	-
	100000	864	599	401	318	295	278	264	253	234	221	210	200	193	186	180	175	171	-	-	-
2-19	5000	1,835	1,835	1,381	1,096	1,018	958	910	870	808	760	722	691	664	641	621	-	-	-	-	-
	10000	1,835	1,638	1,096	870	808	760	722	691	641	603	573	548	527	509	493	-	-	-	-	-
	30000	1,638	1,136	760	603	560	527	501	479	445	418	397	380	365	353	342	-	-	-	-	-
	50000	1,381	958	641	509	472	445	422	404	375	353	335	321	308	298	288	-	-	-	-	-
	100000	1,096	760	509	404	375	353	335	321	298	280	266	254	245	236	229	-	-	-	-	-
2-111	5000	1,975	1,975	1,487	1,180	1,096	1,031	979	937	870	818	777	744	715	690	-	-	-	-	-	-
	10000	1,975	1,763	1,180	937	870	818	777	744	690	650	617	590	567	548	-	-	-	-	-	-
	30000	1,763	1,222	818	650	603	567	539	516	479	450	428	409	393	380	-	-	-	-	-	-
	50000	1,487	1,031	690	548	509	479	455	435	404	380	361	345	332	320	-	-	-	-	-	-
	100000	1,180	818	548	435	404	380	361	345	320	301	286	274	263	254	-	-	-	-	-	-

How to Read the Table

Example A: For a 1" standard duty ball bearing operating at 1000 RPM and desired 100,000 hours L10 life, 154 Lbs is the maximum allowable radial load.
 Example B: If 230 lbs of radial load is applied to a 1" standard duty shaft operating at 1000 RPM, the resulting L10 life is 30,000 hours.



Table 6 - Load/Speed Chart – Sealmaster Ball Bearings continued

Series	L10 Hours	Revolutions Per Minute																			
		50	150	500	1000	1250	1500	1750	2000	2500	3000	3500	4000	4500	5000	5500	6000	6500	7500	8000	10000
2-115	5000	1,972	1,972	1,485	1,178	1,094	1,029	978	935	868	817	776	742	714	689	-	-	-	-	-	-
	10000	1,972	1,760	1,178	935	868	817	776	742	689	649	616	589	567	547	-	-	-	-	-	-
	30000	1,760	1,221	817	649	602	567	538	515	478	450	427	409	393	379	-	-	-	-	-	-
	50000	1,485	1,029	689	547	508	478	454	434	403	379	360	345	331	320	-	-	-	-	-	-
	100000	1,178	817	547	434	403	379	360	345	320	301	286	273	263	254	-	-	-	-	-	-
2-23	5000	2,438	2,438	1,835	1,457	1,352	1,273	1,209	1,156	1,073	1,010	959	918	882	-	-	-	-	-	-	-
	10000	2,438	2,176	1,457	1,156	1,073	1,010	959	918	852	802	762	728	700	-	-	-	-	-	-	-
	30000	2,176	1,509	1,010	802	744	700	665	636	591	556	528	505	486	-	-	-	-	-	-	-
	50000	1,835	1,273	852	676	628	591	561	537	498	469	445	426	410	-	-	-	-	-	-	-
	100000	1,457	1,010	676	537	498	469	445	426	395	372	353	338	325	-	-	-	-	-	-	-
2-27	5000	2,947	2,947	2,219	1,761	1,635	1,538	1,461	1,398	1,298	1,221	1,160	1,109	1,030	969	921	881	-	-	-	-
	10000	2,947	2,631	1,761	1,398	1,298	1,221	1,160	1,109	1,030	969	921	881	-	-	-	-	-	-	-	-
	30000	2,631	1,824	1,221	969	900	847	804	769	714	672	638	611	-	-	-	-	-	-	-	-
	50000	2,219	1,538	1,030	817	759	714	678	649	602	567	538	515	-	-	-	-	-	-	-	-
	100000	1,761	1,221	817	649	602	567	538	515	478	450	427	409	-	-	-	-	-	-	-	-
2-211	5000	3,493	3,493	2,629	2,087	1,937	1,823	1,732	1,656	1,538	1,447	1,375	-	-	-	-	-	-	-	-	-
	10000	3,493	3,118	2,087	1,656	1,538	1,447	1,375	1,315	1,220	1,149	1,091	-	-	-	-	-	-	-	-	-
	30000	3,118	2,162	1,447	1,149	1,066	1,003	953	912	846	796	756	-	-	-	-	-	-	-	-	-
	50000	2,629	1,823	1,220	969	899	846	804	769	714	672	638	-	-	-	-	-	-	-	-	-
	100000	2,087	1,447	969	769	714	672	638	610	567	533	506	-	-	-	-	-	-	-	-	-
2-215	5000	3,710	3,710	2,793	2,217	2,058	1,936	1,839	1,759	1,633	1,537	-	-	-	-	-	-	-	-	-	-
	10000	3,710	3,311	2,217	1,759	1,633	1,537	1,460	1,396	1,296	1,220	-	-	-	-	-	-	-	-	-	-
	30000	3,311	2,296	1,537	1,220	1,132	1,066	1,012	968	899	846	-	-	-	-	-	-	-	-	-	-
	50000	2,793	1,936	1,296	1,029	955	899	854	817	758	713	-	-	-	-	-	-	-	-	-	-
	100000	2,217	1,537	1,029	817	758	713	678	648	602	566	-	-	-	-	-	-	-	-	-	-
2-33	5000	4,353	4,353	3,277	2,601	2,415	2,272	2,158	2,064	1,916	1,803	-	-	-	-	-	-	-	-	-	-
	10000	4,353	3,885	2,601	2,064	1,916	1,803	1,713	1,639	1,521	1,431	-	-	-	-	-	-	-	-	-	-
	30000	3,885	2,694	1,803	1,431	1,329	1,250	1,188	1,136	1,055	992	-	-	-	-	-	-	-	-	-	-
	50000	3,277	2,272	1,521	1,207	1,121	1,055	1,002	958	890	837	-	-	-	-	-	-	-	-	-	-
	100000	2,601	1,803	1,207	958	890	837	795	761	706	664	-	-	-	-	-	-	-	-	-	-
2-37	5000	4,670	4,670	3,516	2,791	2,591	2,438	2,316	2,215	2,056	1,935	-	-	-	-	-	-	-	-	-	-
	10000	4,670	4,169	2,791	2,215	2,056	1,935	1,838	1,758	1,632	1,536	-	-	-	-	-	-	-	-	-	-
	30000	4,169	2,890	1,935	1,536	1,426	1,342	1,274	1,219	1,132	1,065	-	-	-	-	-	-	-	-	-	-
	50000	3,516	2,438	1,632	1,295	1,202	1,132	1,075	1,028	954	898	-	-	-	-	-	-	-	-	-	-
	100000	2,791	1,935	1,295	1,028	954	898	853	816	757	713	-	-	-	-	-	-	-	-	-	-
2-38	5000	5,392	5,392	4,059	3,222	2,991	2,814	2,673	2,557	2,374	-	-	-	-	-	-	-	-	-	-	-
	10000	5,392	4,812	3,222	2,557	2,374	2,234	2,122	2,029	1,884	-	-	-	-	-	-	-	-	-	-	-
	30000	4,812	3,337	2,234	1,773	1,646	1,549	1,471	1,407	1,306	-	-	-	-	-	-	-	-	-	-	-
	50000	4,059	2,814	1,884	1,495	1,388	1,306	1,241	1,187	1,102	-	-	-	-	-	-	-	-	-	-	-
	100000	3,222	2,234	1,495	1,187	1,102	1,037	985	942	874	-	-	-	-	-	-	-	-	-	-	-
2-43	5000	7,476	7,476	5,628	4,467	4,147	3,902	3,707	3,546	-	-	-	-	-	-	-	-	-	-	-	-
	10000	7,476	6,673	4,467	3,546	3,291	3,097	2,942	2,814	-	-	-	-	-	-	-	-	-	-	-	-
	30000	6,673	4,627	3,097	2,458	2,282	2,148	2,040	1,951	-	-	-	-	-	-	-	-	-	-	-	-
	50000	5,628	3,902	2,612	2,074	1,925	1,811	1,721	1,646	-	-	-	-	-	-	-	-	-	-	-	-
	100000	4,467	3,097	2,074	1,646	1,528	1,438	1,366	1,306	-	-	-	-	-	-	-	-	-	-	-	-
3-47	5000	9,371	9,371	7,054	5,599	5,198	4,891	4,646	-	-	-	-	-	-	-	-	-	-	-	-	-
	10000	9,371	8,364	5,599	4,444	4,125	3,882	3,688	-	-	-	-	-	-	-	-	-	-	-	-	-
	30000	8,364	5,799	3,882	3,081	2,860	2,692	2,557	-	-	-	-	-	-	-	-	-	-	-	-	-
	50000	7,054	4,891	3,274	2,599	2,413	2,270	2,157	-	-	-	-	-	-	-	-	-	-	-	-	-
	100000	5,599	3,882	2,599	2,063	1,915	1,802	1,712	-	-	-	-	-	-	-	-	-	-	-	-	-

See notes on top of page G-230.

How to Read the Table

Example A: For a 1" standard duty ball bearing operating at 1000 RPM and desired 100,000 hours L10 life, 154 Lbs is the maximum allowable radial load.

Example B: If 230 lbs of radial load is applied to a 1" standard duty shaft operating at 1000 RPM, the resulting L10 life is 30,000 hours.



Load and Speed continued

1. Table 7 displays the Browning 200 (VS-200) and 300 (VS-300) Series ball bearing load capacities for a given L10 life, speed and shaft size. For VB-200 and VE-200 use equivalent ratings for respective 200 series bore. For VB-300 use equivalent ratings for respective 300 series bore.

2. Values in Table 7 represent radial loads at ideal conditions with press fit mounting to the shaft. ABMA recommends de-rating of slip fit mounted bearings. Elevated operating temperatures can reduce the load capacity of bearing steel where a material de-rating is also recommended.

- a. For operating temperatures up to 200°F, divide the value in the load table by 1.3 to obtain the slip fit derated value.
- b. For units designed for operating temperatures 200°F to 400°F, divide the value in the load table by 1.5 to obtain the slip fit/ elevated temperature de-rate value.
- c. Values in Table 7 represent equivalent radial loads only. For combined radial/thrust loads see page G-222.

3. The **blue shaded area** represents maximum recommended load for given operating speed based on load of 25% BDR. It is NOT recommended to exceed these loads in general industrial applications. See note on page G-222 for high load applications.

4. Areas designated by “-” exceed maximum value for standard bearings. See note on page G-223.

5. Consult Application Engineering for load and speed applications not covered in this table.

Table 7 - Load/Speed Chart – Browning 200 and 300 Series Ball Bearings

Series	L10 Hours	Revolutions Per Minute																								
		50	150	250	500	750	1000	1250	1500	1750	2000	2500	3000	3500	4000	4500	5000	5500	6000	6500	7500					
L-10	5000	527	527	500	397	347	315	292	275	261	250	232	218	207	198	184	173	165	157	151	146	142	138	134	128	
	10000	527	470	397	315	275	250	232	218	207	198	184	173	165	157	151	146	142	138	134	128	122	118	115	111	
	30000	470	326	275	218	191	173	161	151	144	138	128	120	114	109	105	101	98	95	93	89	85	83	80	78	75
	50000	397	275	232	184	161	146	136	128	121	116	108	101	96	92	89	85	83	80	78	75	72	68	64	62	59
	100000	315	218	184	146	128	116	108	101	96	92	85	80	76	73	70	68	66	64	62	59	57	54	51	48	45
2-012	5000	652	652	619	491	429	390	362	341	324	310	287	270	257	246	235	228	221	215	209	203	197	191	185	179	
	10000	652	583	491	390	341	310	287	270	257	246	228	215	204	195	188	181	175	170	166	161	156	151	146	141	
	30000	583	404	341	270	236	215	199	188	178	170	158	149	141	135	130	126	122	118	115	111	107	103	99	95	
	50000	491	341	287	228	199	181	168	158	150	144	133	126	119	114	110	106	103	100	97	94	91	88	85	82	79
	100000	390	270	228	181	158	144	133	126	119	114	106	100	95	91	87	84	81	79	77	74	71	68	65	62	59
2-015	5000	700	700	664	527	461	418	388	366	347	332	308	290	276	264	250	239	230	224	218	212	206	200	194	188	
	10000	700	625	527	418	366	332	308	290	276	264	246	230	219	209	201	194	188	182	176	170	164	158	152	146	
	30000	625	433	366	290	253	230	214	201	191	183	170	160	152	145	139	135	130	126	122	118	114	110	106	102	
	50000	527	366	308	245	214	194	180	170	161	154	143	135	128	122	118	114	110	106	102	98	94	90	86	82	78
	100000	418	290	245	194	170	154	143	135	128	122	114	107	102	97	93	90	87	84	81	78	75	72	69	66	63
2-13	5000	1095	1095	1,039	825	720	654	608	572	543	519	482	454	431	412	396	380	364	348	332	316	300	284	268	252	
	10000	1095	978	825	654	572	519	482	454	431	412	383	360	342	327	315	300	284	268	252	236	220	204	188	172	
	30000	978	678	572	454	396	360	334	315	299	286	265	250	237	227	218	209	199	189	179	169	159	149	139	129	
	50000	825	572	482	383	334	304	282	265	252	241	224	211	200	191	184	176	168	160	152	144	136	128	120	112	104
	100000	654	454	383	304	265	241	224	211	200	191	178	167	159	152	146	140	134	128	122	116	110	104	98	92	86
2-17	5000	1,446	1,446	1,371	1,088	951	864	802	755	717	686	636	599	569	544	505	475	452	432	412	392	372	352	332	312	
	10000	1,446	1,290	1,088	864	755	686	636	599	569	544	505	475	452	432	412	392	372	352	332	312	292	272	252	232	
	30000	1,290	895	755	599	523	475	441	415	394	377	350	330	313	299	284	269	254	239	224	209	194	179	164	149	
	50000	1,088	755	636	505	441	401	372	350	333	318	295	278	264	253	242	231	220	209	198	187	176	165	154	143	
	100000	864	599	505	401	350	318	295	278	264	253	234	221	210	200	190	180	170	160	150	140	130	120	110	100	90
2-19	5000	1,835	1,835	1,741	1,381	1,207	1,096	1,018	958	910	870	808	760	722	691	661	631	601	571	541	511	481	451	421	391	
	10000	1,835	1,638	1,381	1,096	958	870	808	760	722	691	641	603	573	543	513	483	453	423	393	363	333	303	273	243	
	30000	1,638	1,136	958	760	664	603	560	527	501	479	445	418	397	377	357	337	317	297	277	257	237	217	197	177	
	50000	1,381	958	808	641	560	509	472	445	422	404	375	353	335	319	301	284	267	250	233	216	199	182	165	148	
	100000	1,096	760	641	509	445	404	375	353	335	321	298	280	266	250	234	218	202	186	170	154	138	122	106	90	
2-111	5000	1,975	1,975	1,874	1,487	1,299	1,180	1,096	1,031	979	937	870	818	777	744	690	650	610	570	530	490	450	410	370	330	
	10000	1,975	1,763	1,487	1,180	1,031	937	870	818	777	744	690	650	610	570	530	490	450	410	370	330	290	250	210	170	
	30000	1,763	1,222	1,031	818	715	650	603	567	539	516	479	450	420	390	360	330	300	270	240	210	180	150	120	90	
	50000	1,487	1,031	870	690	603	548	509	479	455	435	404	380	351	321	291	261	231	201	171	141	111	81	51	21	
	100000	1,180	818	690	548	479	435	404	380	361	345	320	301	281	261	241	221	201	181	161	141	121	101	81	61	
2-115	5000	1,972	1,972	1,871	1,485	1,297	1,178	1,094	1,029	978	935	868	817	776	742	689	649	609	569	529	489	449	409	369	329	
	10000	1,972	1,760	1,485	1,178	1,029	935	868	817	776	742	689	649	609	569	529	489	449	409	369	329	289	249	209	169	
	30000	1,760	1,221	1,029	817	714	649	602	567	538	515	478	450	420	390	360	330	300	270	240	210	180	150	120	90	
	50000	1,485	1,029	868	689	602	547	508	478	454	434	403	379	350	320	290	260	230	200	170	140	110	80	50	20	
	100000	1,178	817	689	547	478	434	403	379	360	345	320	301	281	261	241	221	201	181	161	141	121	101	81	61	
2-23	5000	2,438	2,438	2,312	1,835	1,603	1,457	1,352	1,273	1,209	1,156	1,073	1,010	959	918	852	802	752	702	652	602	552	502	452	402	
	10000	2,438	2,176	1,835	1,457	1,273	1,156	1,073	1,010	959	918	852	802	752	702	652	602	552	502	452	402	352	302	252	202	
	30000	2,176	1,509	1,273	1,010	882	802	744	700	665	636	591	551	511	471	431	391	351	311	271	231	191	151	111	71	
	50000	1,835	1,273	1,073	852	744	676	628	591	561	537	498	458	418	378	338	298	258	218	178	138	98	58	18	78	
	100000	1,457	1,010	852	676	591	537	498	469	445	426	395	355	315	275	235	195	155	115	75	35	75	35	75	35	
2-27	5000	2,947	2,947	2,795	2,219	1,938	1,761	1,635	1,538	1,461	1,398	1,298	1,209	1,156	1,073	1,010	959	918	852	802	752	702	652	602	552	
	10000	2,947	2,631	2,219	1,761	1,538	1,398	1,298	1,221	1,160	1,109	1,030	970	919	852	802	752	702	652	602	552	502	452	402	352	
	30000	2,631	1,824	1,538	1,221	1,067	969	900	847	804	769	714	674	634	594	554	514	474	434	394	354	314	274	234	194	
	50000	2,219	1,538	1,298	1,030	900	817	759	714	678	649	602	562	522	482	442	402	362	322	282	242	202	162	122	82	
	100000	1,761	1,221	1,030	817	714	649	602	567	538	515	478	449	419	389	359	329	289	249	209	169	129	89	49	9	

Load and Speed continued

1. Table 8 displays the Browning 100 setscrew locking ball bearing (VS-100) load capacities for a given L10 life, speed and shaft size. For VE-100, RUBRE-100, RUBRS-100, SLS-100, LE-100, LR-100, LRS-100, LS-100 use equivalent ratings for respective 100 series bore.

2. Values in Table 8 represent radial loads at ideal conditions with press fit mounting to the shaft. ABMA recommends de-rating of slip fit mounted bearings. Elevated operating temperatures can reduce the load capacity of bearing steel where a material de-rating is also recommended.

- For operating temperatures up to 200°F, divide the value in the load table by 1.3 to obtain the slip fit derated value.
- For units designed for operating temperatures 200°F to 400°F, divide the value in the load table by 1.5 to obtain the slip fit/ elevated temperature de-rate value.
- Values in Table 8 represent equivalent radial loads only. For combined radial/thrust loads see page G-222.

3. The **blue shaded area** represents maximum recommended load for given operating speed based on load of 17% BDR. It is NOT recommended to exceed these loads in general industrial applications. See note on page G-222 for high load applications.

4. Areas designated by “-” exceed maximum value for standard bearings. See note on page G-223.

5. Consult Application Engineering for load and speed applications not covered in this table.

Table 8 - Load/Speed Chart – Browning 100 Series Ball Bearings

Series	L10 Hours	Revolutions Per Minute															
		50	150	250	500	750	1000	1250	1500	1750	2000	2500	3000	3500	4000	4500	5000
L-10	5000	351	351	351	351	347	315	292	275	261	250	232	218	207	198	191	184
	10000	351	351	351	315	275	250	232	218	207	198	184	173	165	157	151	146
	30000	351	326	275	218	191	173	161	151	144	138	128	120	114	109	105	101
	50000	351	275	232	184	161	146	136	128	121	116	108	101	96	92	89	85
	100000	315	218	184	146	128	116	108	101	96	92	85	80	76	73	70	68
2-012	5000	435	435	435	435	429	390	362	341	324	310	287	270	257	246	236	228
	10000	435	435	435	390	341	310	287	270	257	246	228	215	204	195	188	181
	30000	435	404	341	270	236	215	199	188	178	170	158	149	141	135	130	126
	50000	435	341	287	228	199	181	168	158	150	144	133	126	119	114	110	106
	100000	390	270	228	181	158	144	133	126	119	114	106	100	95	91	87	84
2-015	5000	466	466	466	466	461	418	388	366	347	332	308	290	276	-	-	-
	10000	466	466	466	418	366	332	308	290	276	264	245	230	219	-	-	-
	30000	466	433	366	290	253	230	214	201	191	183	170	160	152	-	-	-
	50000	466	366	308	245	214	194	180	170	161	154	143	135	128	-	-	-
	100000	418	290	245	194	170	154	143	135	128	122	114	107	102	-	-	-
2-13	5000	730	730	730	730	720	654	608	572	543	519	482	454	-	-	-	-
	10000	730	730	730	654	572	519	482	454	431	412	383	360	-	-	-	-
	30000	730	678	572	454	396	360	334	315	299	286	265	250	-	-	-	-
	50000	730	572	482	383	334	304	282	265	252	241	224	211	-	-	-	-
	100000	654	454	383	304	265	241	224	211	200	191	178	167	-	-	-	-
2-17	5000	963	963	963	963	951	864	802	755	717	686	636	-	-	-	-	-
	10000	963	963	963	864	755	686	636	599	569	544	505	-	-	-	-	-
	30000	963	895	755	599	523	475	441	415	394	377	350	-	-	-	-	-
	50000	963	755	636	505	441	401	372	350	333	318	295	-	-	-	-	-
	100000	864	599	505	401	350	318	295	278	264	253	234	-	-	-	-	-
2-19	5000	1,223	1,223	1,223	1,223	1,207	1,096	1,018	958	910	870	808	-	-	-	-	-
	10000	1,223	1,223	1,223	1,096	958	870	808	760	722	691	641	-	-	-	-	-
	30000	1,223	1,136	958	760	664	603	560	527	501	479	445	-	-	-	-	-
	50000	1,223	958	808	641	560	509	472	445	422	404	375	-	-	-	-	-
	100000	1,096	760	641	509	445	404	375	353	335	321	298	-	-	-	-	-
2-111	5000	1,316	1,316	1,316	1,316	1,299	1,180	1,096	1,031	979	937	-	-	-	-	-	-
	10000	1,316	1,316	1,316	1,180	1,031	937	870	818	777	744	-	-	-	-	-	-
	30000	1,316	1,222	1,031	818	715	650	603	567	539	516	-	-	-	-	-	-
	50000	1,316	1,031	870	690	603	548	509	479	455	435	-	-	-	-	-	-
	100000	1,180	818	690	548	479	435	404	380	361	345	-	-	-	-	-	-
2-115	5000	1,314	1,314	1,314	1,314	1,297	1,178	1,094	1,029	978	935	-	-	-	-	-	-
	10000	1,314	1,314	1,314	1,178	1,029	935	868	817	776	742	-	-	-	-	-	-
	30000	1,314	1,221	1,029	817	714	649	602	567	538	515	-	-	-	-	-	-
	50000	1,314	1,029	868	689	602	547	508	478	454	434	-	-	-	-	-	-
	100000	1,178	817	689	547	478	434	403	379	360	345	-	-	-	-	-	-
2-23	5000	1,625	1,625	1,625	1,625	1,603	1,457	1,352	1,273	1,209	-	-	-	-	-	-	-
	10000	1,625	1,625	1,625	1,457	1,273	1,156	1,073	1,010	959	-	-	-	-	-	-	-
	30000	1,625	1,509	1,273	1,010	882	802	744	700	665	-	-	-	-	-	-	-
	50000	1,625	1,273	1,073	852	744	676	628	591	561	-	-	-	-	-	-	-
	100000	1,457	1,010	852	676	591	537	498	469	445	-	-	-	-	-	-	-

How to Read the Table

Example A: For a 1" standard duty ball bearing operating at 1000 RPM and desired 100,000 hours L10 life, 154 Lbs is the maximum allowable radial load.

Example B: If 230 lbs of radial load is applied to a 1" standard duty shaft operating at 1000 RPM, the resulting L10 life is 30,000 hours.



Mounted Ball Bearing Engineering see page G-220.

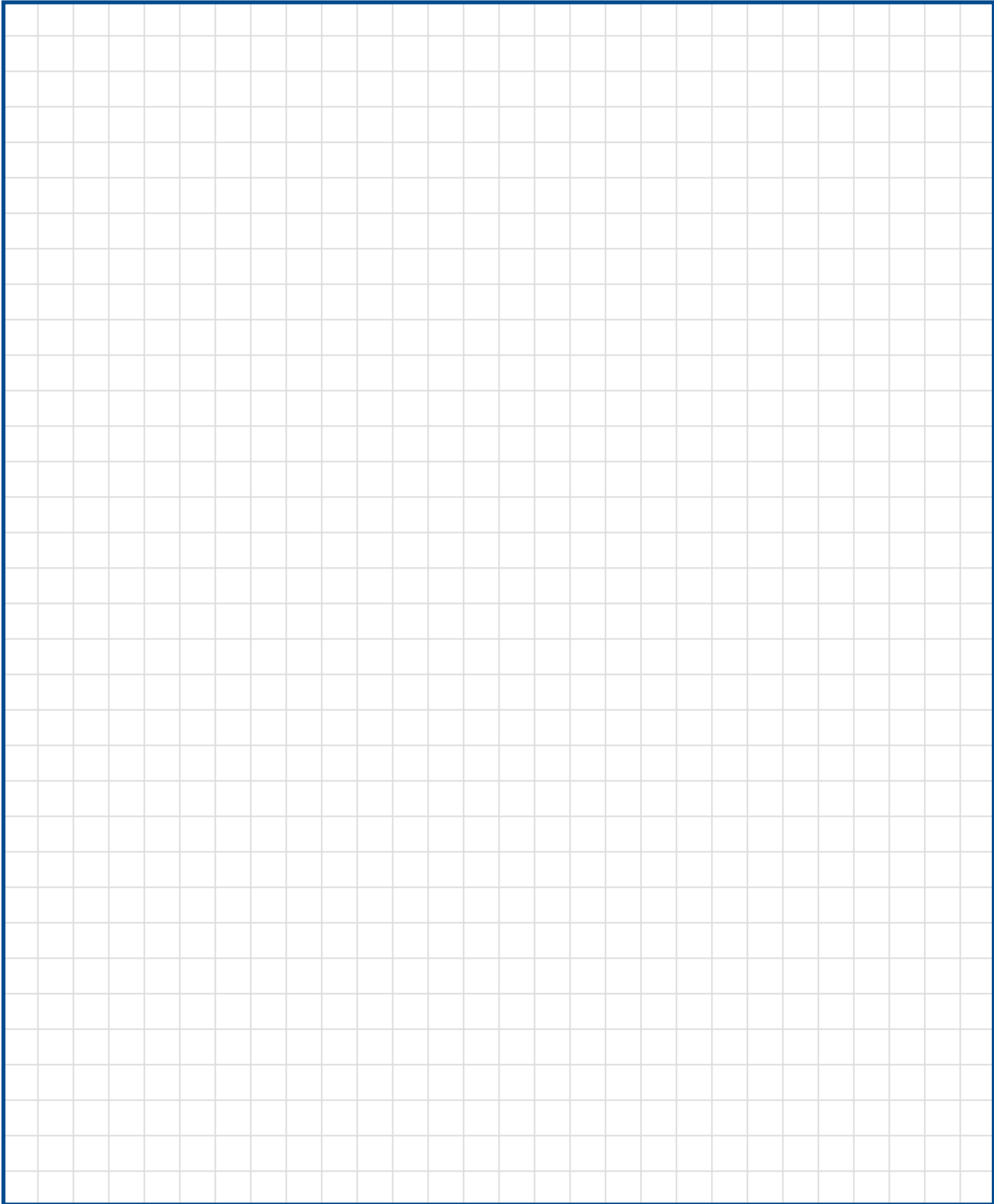

Ball Bearing Maximum Speed Rating Tables

Tables 9-13 display the maximum speed rating for various ball bearing seals and locking devices. Values in the table represent speeds at ideal conditions. Other application factors may reduce the speed rating of a bearing.

Table 9 – Sealmaster Gold Standard Duty Maximum Speed Rating

Standard Duty and ER Bearings					MAX SEAL SPEED REVOLUTIONS PER MINUTE									
					Standard Sealmaster Gold									
					Locking	Setscrew	Skwezloc Locking Collar or Double Setscrew	Setscrew, Skwezloc Locking Collar and Double Setscrew						
Series	Bore Diameter		Standard Duty	ER	Suffix	Standard, A, AS, X	C	2C	3C	F	SF	U, BF	VA, VS	H
	inch	mm	Insert			Standard Felt Backed off Felt (AS) Nomex (A) No Felt (X)	Contact	Double Contact Seal (Progard)	Triple Contact Seal (Safeguard)	High Temp Contact Seal - Fiberglass (Heatgard)	High Temp Double Contact Seal - Fiberglass (Heatgard Plus)	Spring Seal (UltraGard)	High Temp Spring Seal (HeatGard Ultra)	High Performance Seal
2-012	1/2	-	2-08	ER-8	7300	10200	6450	1600	N/A	1600	N/A	2800	N/A	3100
	9/16	-	2-09	ER-9										
	5/8	-	2-010	ER-10										
	11/16	-	2-011	ER-11										
	3/4	-	2-012	ER-12										
	-	20	5204	ER-204										
2-015	13/16	-	2-013	ER-13	6350	9000	6350	N/A	550	1400	N/A	2500	2500	2700
	7/8	-	2-014	ER-14										
	15/16	-	2-015	ER-15										
	-	25	5205	ER-205										
	1	-	2-1	ER-16										
2-13	1 1/16	-	2-11	ER-17	5450	7600	5450	N/A	500	1050	500	2200	2200	2300
	1 1/8	-	2-12	ER-18										
	-	30	5206	ER-206										
	1 3/8	-	2-13	ER-19										
	1 1/4	-	1-14	ER-20R										
2-17	1 1/4	-	2-14	ER-20	4650	6500	4650	N/A	450	1000	450	N/A	1900	2000
	1 5/16	-	2-15	ER-21										
	1 3/8	-	2-16	ER-22										
	-	35	5207	ER-207										
	1 7/16	-	2-17	ER-23										
2-19	1 1/2	-	2-18	ER-24	4150	5850	4150	N/A	400	925	400	N/A	1700	1750
	1 9/16	-	2-19	ER-25										
	-	40	5208	ER-208										
2-111	1 5/8	-	2-110	ER-26	3800	5300	3800	N/A	350	850	350	N/A	1500	1600
	1 11/16	-	2-111	ER-27										
	1 3/4	-	2-112	ER-28										
	-	45	5209	ER-209										

If seal max speed in this chart exceeds bearing max speed from rating tables or speed that is deemed acceptable for the application, lowest applicable speed applies.



MAX SEAL SPEED REVOLUTIONS PER MINUTE													
Custom Select Suffix													
Setscrew, Skwezloc Locking Collar and Double Setscrew				Setscrew	Skwezloc Locking Collar or Double Setscrew	Skwezloc Locking Collar	All	Locking	Standard Duty and ER Bearings				
HT, HTA, HI	HTC	LO	XLO	CXU		HS	DRT	Suffix					
High Temperature Options		Low Drag Options		Air Handling		High Speed	High Contamination			Bore Diameter	Standard Duty	ER	Series
									inch	mm	Insert		
3200	800	5800	2900	7300	10200	11700	1600		1/2	-	2-08	ER-8	2-012
									9/16	-	2-09	ER-9	
									5/8	-	2-010	ER-10	
									11/16	-	2-011	ER-11	
									3/4	-	2-012	ER-12	
									-	20	5204	ER-204	
2750	800	5000	2500	6350	9000	10200	550		13/16	-	2-013	ER-13	2-015
									7/8	-	2-014	ER-14	
									15/16	-	2-015	ER-15	
									-	25	5205	ER-205	
									1	-	2-1	ER-16	
2400	700	4300	2150	5450	7600	8700	500		1 1/16	-	2-11	ER-17	2-13
									1 1/8	-	2-12	ER-18	
									-	30	5206	ER-206	
									1 3/8	-	2-13	ER-19	
									1 1/4	-	1-14	ER-20R	
2200	600	3700	1850	4650	6500	7450	450		1 1/4	-	2-14	ER-20	2-17
									1 5/16	-	2-15	ER-21	
									1 3/8	-	2-16	ER-22	
									-	35	5207	ER-207	
									1 7/16	-	2-17	ER-23	
1800	500	3300	1650	4150	5850	6700	400		1 1/2	-	2-18	ER-24	2-19
									1 9/16	-	2-19	ER-25	
									-	40	5208	ER-208	
1650	500	3000	1500	3800	5300	6050	350		1 5/8	-	2-110	ER-26	2-111
									1 11/16	-	2-111	ER-27	
									1 3/4	-	2-112	ER-28	
									-	45	5209	ER-209	

Table 9 – Sealmaster Gold Standard Duty Maximum Speed Rating continued

Standard Duty and ER Bearings					MAX SEAL SPEED REVOLUTIONS PER MINUTE										
					Standard Sealmaster Gold										
					Locking	Setscrew		Skwezloc Locking Collar or Double Setscrew	Setscrew, Skwezloc Locking Collar and Double Setscrew						
Series		Bore Diameter		Standard Duty	ER	Suffix	Standard, A, AS, X	C	2C	3C	F	SF	U, BF	VA, VS	H
		inch	mm	Insert			Standard Felt Backed off Felt (AS) Nomex (A) No Felt (X)	Contact	Double Contact Seal (Progard)	Triple Contact Seal (Safeguard)	High Temp Contact Seal - Fiberglass (Heatgard)	High Temp Double Contact Seal - Fiberglass (Heatgard Plus)	Spring Seal (UltraGard)	High Temp Spring Seal (HeatGard Ultra)	High Performance Seal
2-115	1 13/16	-	2-113	ER-29		3550	5000	3550	N/A	325	775	325	1400	N/A	1500
	1 7/8	-	2-114	ER-30											
	1 15/16	-	2-115	ER-31											
	-	50	5210	ER-210											
	2	-	1-2	ER-32R											
2-23	2	-	2-2	ER-32		3250	4500	3250	700	300	700	300	1300	N/A	1350
	2 1/8	-	2-22	ER-34											
	-	55	5211	ER-211											
	2 3/16	-	2-23	ER-35											
2-27	2 1/4	-	2-24	ER-36		3000	4100	2550	650	N/A	650	250	1200	N/A	1250
	-	60	5212	ER-212											
	2 3/8	-	2-26	ER-38											
	2 7/16	-	2-27	ER-39											
2-211	2 1/2	-	-	ER-40		2500	3600	2225	550	N/A	550	225	N/A	N/A	1050
	2 11/16	-	2-211	ER-43											
	-	70	5214	ER-214											
2-215*	2 7/8	-	2-214	ER-46		2450	3400	2100	525	N/A	525	200	N/A	N/A	2500*
	2 15/16	-	2-215	ER-47											
	-	75	5215	ER-215											
2-33	3	-	-	ER-48		2250	3150	1950	500	N/A	500	N/A	N/A	N/A	N/A
	-	80	5216	ER-216											
	3 3/16	-	2-33	ER-51											
2-37	3 1/4	-	2-34	ER-52		2125	3000	1850	450	N/A	450	N/A	N/A	N/A	N/A
	3 3/8	-	2-36	ER-54											
	3 7/16	-	2-37	ER-55											
2-38	3 1/2	-	2-38	-		2000	2800	1725	425	N/A	425	N/A	N/A	N/A	N/A
	-	90	5218	-											
2-43	3 15/16	-	-	ER-63		1700	2400	1450	375	N/A	375	N/A	N/A	N/A	N/A
	-	100	-												
	4	-	-	ER-64											

If seal max speed in this chart exceeds bearing max speed from rating tables or speed that is deemed acceptable for the application, lowest applicable speed applies.

*2-215 series uses a double lip seal vs. our triple lip high performance seal (HPS).



MAX SEAL SPEED REVOLUTIONS PER MINUTE													
Custom Select Suffix													
Setscrew, Skwezloc Locking Collar and Double Setscrew				Setscrew	Skwezloc Locking Collar or Double Setscrew	Skwezloc Locking Collar	All	Locking	Standard Duty and ER Bearings				
HT, HTA, HI	HTC	LO	XLO	CXU		HS	DRT	Suffix	Bore Diameter		Standard Duty	ER	Series
High Temperature Options		Low Drag Options		Air Handling		High Speed	High Contamination		inch	mm	Insert		
1550	400	2800	1400	3550	5000	5700	325		1 13/16	-	2-113	ER-29	2-115
									1 7/8	-	2-114	ER-30	
									1 15/16	-	2-115	ER-31	
									-	50	5210	ER-210	
									2	-	1-2	ER-32R	
1400	350	2500	1250	3250	4500	5150	300		2	-	2-2	ER-32	2-23
									2 1/8	-	2-22	ER-34	
									-	55	5211	ER-211	
									2 3/16	-	2-23	ER-35	
1250	325	2300	1150	3000	4100	4700	650		2 1/4	-	2-24	ER-36	2-27
									-	60	5212	ER-212	
									2 3/8	-	2-26	ER-38	
1100	275	2000	1000	2500	3600	N/A	550		2 7/16	-	2-27	ER-39	2-21
									2 1/2	-	-	ER-40	
									2 11/16	-	2-211	ER-43	
1050	250	1900	950	2450	3400	N/A	525		-	70	5214	ER-214	2-215
									2 7/8	-	2-214	ER-46	
									2 15/16	-	2-215	ER-47	
950	250	1750	900	2250	3150	N/A	500		-	75	5215	ER-215	2-33
									3	-	-	ER-48	
									3 3/16	-	2-33	ER-51	
900	225	1650	800	2125	3000	N/A	450		3 1/4	-	2-34	ER-52	2-37
									3 3/8	-	2-36	ER-54	
									3 7/16	-	2-37	ER-55	
850	200	1550	750	2000	2800	N/A	425		3 1/2	-	2-38	-	2-38
									-	90	5218	-	
700	200	1300	650	1700	2400	N/A	375		3 15/16	-	-	ER-63	2-43
									-	100	-	-	
									4	-	-	ER-64	

Table 10 – Sealmaster Gold Medium Duty Maximum Speed

Medium Duty					MAX SEAL SPEED REVOLUTIONS PER MINUTE								
					Standard Sealmaster Gold								
					Locking	Setscrew	Skwezloc Locking Collar or Double Setscrew	Setscrew, Skwezloc Locking Collar and Double Setscrew					
Bore Diameter		Unit Size	Insert	Standard, AS, X	C	2C	3C	SF	U, BF	VA, VS	H		
Series	inch	mm		Standard Felt Backed off Felt (AS) Nomex (A) No Felt (X)	Contact	Double Contact Seal (Progard)	Triple Contact Seal (Safeguard)	High Temp Double Contact Seal - Fiberglass (Heatgard Plus)	Spring Seal (UltraGard)	FKM Spring Seal (HeatGard Ultra)	High Performance Seal		
2-13	15/16	-	15	3-015	5450	7600	5450	N/A	500	500	2200	2200	2300
	-	25	305	5305									
	1	-	16	3-1									
2-17	-	30	306	5306	4650	6500	4650	N/A	450	450	N/A	1900	2000
	1 3/16	-	19	3-13									
2-19	-	35	307	5307	4150	5850	4150	N/A	400	400	N/A	1700	1750
	1 7/16	-	23	3-17									
2-111	1 1/2	-	24	3-18	3800	5300	3800	N/A	350	350	N/A	1500	1600
	-	40	308	5308									
2-115	1 11/16	-	27	3-111	3550	5000	3550	N/A	325	325	1400	N/A	1500
	1 3/4	-	28	3-112									
	-	45	309	5309									
2-23	1 15/16	-	31	3-115	3250	4500	3250	700	300	300	1300	N/A	1350
	-	50	310	5310									
2-27	-	55	311	5311	3000	4100	2550	650	N/A	250	1200	N/A	1250
	2 3/16	-	35	3-23									
2-211	2 7/16	-	39	3-27	2500	3600	2250	550	N/A	225	N/A	N/A	1050
	2 1/2	-	40	3-28									
	-	65	313	5313									
2-215	2 11/16	-	43	3-211	2450	3400	2100	525	N/A	200	N/A	N/A	2500*
	-	70	314	5314									
2-33	2 15/16	-	47	3-215	2250	3150	1950	500	N/A	N/A	N/A	N/A	N/A
	-	75	315	5315									
	3	-	48	3-3									
2-37	-	80	316	5316	2125	3000	1850	450	N/A	N/A	N/A	N/A	N/A
	3 3/16	-	51	3-33									
2-38	3 7/16	-	55	3-37	2000	2800	1725	425	N/A	N/A	N/A	N/A	N/A
2-43	3 15/16	-	63	3-315	1700	2400	1450	375	N/A	N/A	N/A	N/A	N/A
	-	100	320	5320									
	4	-	64	3-4									
3-47	4 7/16	-	71	3-47	1375	1950	N/A	N/A	N/A	N/A	N/A	N/A	N/A
	4 15/16	-	79	3-415									

If seal max speed in this chart exceeds bearing max speed from rating tables or speed that is deemed acceptable for the application, lowest applicable speed applies.



MAX SEAL SPEED REVOLUTIONS PER MINUTE												
Custom Select Suffix												
Setscrew, Skwezloc Locking Collar and Double Setscrew				Setscrew	Skwezloc Locking Collar or Double Setscrew	Skwezloc Locking Collar	All	Medium Duty			Locking	Series
HT, HTA, HI	HTC	LO	XLO	CXU		HS	DRT			Suffix		
High Temperature Options		Low Drag		Air Handling		High Speed	High Contamination	Bore Diameter		Unit Size	Insert	
								inch	mm			
2400	400	4300	2150	5450	7600	8700	500	15/16	-	15	3-015	2-13
								-	25	305	5305	
								1	-	16	3-1	
2200	350	3700	1850	4650	6500	7450	450	-	30	306	5306	2-17
								1 3/16	-	19	3-13	
1800	350	3300	1650	4150	5850	6700	400	-	35	307	5307	2-19
								1 7/16	-	23	3-17	
1650	350	3000	1500	3800	5300	6050	350	1 1/2	-	24	3-18	2-111
								-	40	308	5308	
1550	350	2800	1400	3550	5000	5700	325	1 11/16	-	27	3-111	2-115
								1 3/4	-	28	3-112	
								-	45	309	5309	
1400	350	2500	1250	3250	4500	5150	300	1 15/16	-	31	3-115	2-23
								-	50	310	5310	
1250	325	2300	1150	3000	4100	4700	650	-	55	311	5311	2-27
								2 3/16	-	35	3-23	
1100	275	2000	1000	2500	3600	N/A	550	2 7/16	-	39	3-27	2-211
								2 1/2	-	40	3-28	
								-	65	313	5313	
1050	250	1900	950	2450	3400	N/A	525	2 11/16	-	43	3-211	2-215
								-	70	314	5314	
950	250	1750	900	2250	3150	N/A	500	2 15/16	-	47	3-215	2-33
								-	75	315	5315	
								3	-	48	3-3	
900	225	1650	800	2125	3000	N/A	450	-	80	316	5316	2-37
								3 3/16	-	51	3-33	
850	200	1550	750	2000	2800	N/A	425	3 7/16	-	55	3-37	2-38
700	200	1300	650	1700	2400	N/A	375	3 15/16	-	63	3-315	2-43
								-	100	320	5320	
								4	-	64	3-4	
600	N/A	1050	525	1375	1950	N/A	N/A	4 7/16	-	71	3-47	3-47
								4 15/16	-	79	3-415	

Table 11 – Sealmaster Material Handling Bearing Maximum Speed Rating

Series	Bore Diameter		Unit Size	Insert		Max. Seal Speed Revolutions Per Minute
	inch	mm		Setscrew	Skwezloc Locking Collar	
2-012	3/4	-	12	MH-12	MH-12T	6500
	-	20	204	MH-204	MH-204T	
2-015	-	25	205	MH-205	MH-205T	5500
	1	-	16	MH-16	MH-16T	
2-13	-	30	206	MH-206	MH-206T	4500
	1 3/6	-	19	MH-19	MH-19T	
	1 1/4S	-	20S	MH-20R	MH-20RT	
2-17	1 1/4	-	20	MH-20	MH-20T	4000
	1 7/16	-	23	MH-23	MH-23T	
2-19	1 1/2	-	24	MH-24	MH-24T	3500
2-111	1 11/16	-	27	MH-27	MH-27T	3000
2-115	1 15/16	-	31	MH-31	MH-31T	3000
	-	50	210	MH-210	MH-210T	
2-23	2	-	32	MH-32	MH-32T	2500
	2 3/16	-	35	MH-35	MH-35T	
2-27	2 7/16	-	39	MH-39	MH-39T	2500



Table 12 – Browning 100 and 200 Maximum Speed Rating

Series	100 Series, 200 Series and VER Bearings					Max. Seal Speed Revolutions Per Minute		
	Bore Diameter		100 Series	200 Series	VER	100 Series	200 Series	VER
	inch	mm	Insert	Insert		Contact	Contact + Flinger	Contact + Flinger
L-10	1/2	-	VS-108	VS-208	-	5000	7500	-
2-012			-	-	VER-208	-	-	6500
L-10	5/8	-	VS-110	VS-210	-	5000	7500	-
2-012			-	-	VER-210	-	-	6500
2-012	3/4	-	VS-112	VS-212	VER-212	4000	6500	6500
	-	20	-	VS-20 MM	-			
2-015	7/8	-	VS-114	VS-214	VER-214	3500	5500	5500
	15/16	-	VS-115	VS-215	VER-215			
	-	25	-	VS-25 MM	-			
	1	-	VS-116	VS-216	VER-216			
2-13	1 1/16	-	-	-	VER-217	3000	4500	4500
	1 1/8	-	VS-118	VS-218	VER-218			
	-	30	-	VS-30 MM	-			
	1 3/6	-	VS-119	VS-219	VER-219			
	1 1/4	-	VS-120S	VS-220S	VER-220S			
2-17	1 1/4	-	VS-120	VS-220	VER-220	2500	4000	4000
	1 3/8	-	VS-122	VS-222	VER-222			
	-	35	-	VS-35 MM	-			
	1 7/16	-	VS-123	VS-223	VER-223			
2-19	1 1/2	-	VS-124	VS-224	VER-224	2500	3500	3500
	1 9/16	-	-	-	VER-225			
	-	40	-	VS-40 MM	-			
2-111	1 5/8	-	-	VS-226	VER-226	2000	3000	3000
	1 11/16	-	VS-127	VS-227	VER-227			
	1 3/4	-	VS-128	VS-228	VER-228			
	-	45	-	VS-45 MM	-			
2-115	1 7/8	-	-	-	VER-230	2000	3000	3000
	1 15/16	-	VS-131	VS-231	VER-231			
	-	50	-	VS-50 MM	-			
	2	-	VS-132S	VS-232S	VER-232S			
2-23	2	-	VS-132	VS-232	VER-232	1750	2500	2500
	-	55	-	VS-55 MM	-			
	2 3/16	-	VS-135	VS-235	VER-235			
2-27	2 1/4	-	-	VS-236	VER-236	-	2500	2500
	2 3/8	-	-	-	VER-238			
	2 7/16	-	-	VS-239	VER-239			

Setscrew locking 100, 200, 300 series and VER's shown.

For VE-100, RUBRE-100, RUBRS-100, SLS-100, LE-100, LR-100, LRS-100, LS-100 use equivalent limits respective 100 series bore.

For VB-200, VE-200 equivalent limits for respective 200 series bore.

**Table 13 – Browning 300 Maximum Speed Rating**

300 Series Bearing			Max. Seal Speed Revolutions Per Minute
Bore Diameter		300 Series	300 Series
inch	mm	Insert	Contact + Flinger
1	25.4	VS-316	4500
1 3/16	30.2	VS-319	4000
1 1/4	31.8	VS-220	
1 7/16	36.5	VS-323	3500
1 1/2	38.1	VS-324	3000
1 11/16	42.9	VS-327	
1 3/4	44.5	VS-328	
1 15/16	49.2	VS-331	2500
2 3/16	55.6	VS-335	

For VB-300 equivalent limits for respective 300 series bore.



Lock Types

“Slip Fit” Mounting

Mounted Ball Bearings are designed to slip fit onto the shaft. Slip fit means that the shaft is usually slightly smaller, and the inner ring bore is slightly larger than the nominal shaft sizes listed in the bearing tables. Slip fit mounting is very popular and economical as it does not require specialized equipment or tooling to mount the bearing on the shaft. Reliability of the lock is still dependent on the proper mounting techniques and proper shaft size control.

Shaft Locking System Selection

Selection of the shaft locking system may be dependent on some or all of the following application criteria:

- Lock Reliability
- Shaft Run-Out
- Vibrating Systems
- Vibration Reduction (Isolation Devices)
- Shaft Fretting
- Distress On The Shaft Surface
- Shafting Material
- Space On The Shaft
- Shaft Orientation (Vertical, Horizontal)
- Ease Of Installation

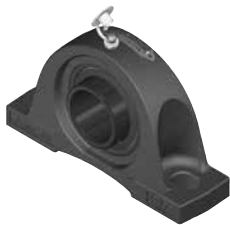

Single Sided (Single Lock) Setscrew Locking System

Single sided setscrew lock has an extended inner ring on one side of the bearing. This locking system is held to the shaft by two setscrews. Single lock is the most popular bearing mounting method for Mounted

Ball Bearings. It is easy to mount because it requires tightening only two setscrews and takes up minimal space along the shaft. Sealmaster and Browning Mounted Ball Bearings have a unique package of features including: wide inner ring design, zone hardened inner rings, specially designed setscrews and 120° setscrew position. These features are unmatched in the mounted bearing industry and are designed to maximize lock reliability.

Single lock setscrew design is specified in a wide range of applications for moderate loads and speeds. This lock is sometimes specified in flange block and cartridge housings because of inaccessibility of back side setscrews. Upset setscrew marks on the shaft can be minimized for removal of the bearing by removing the setscrews and using a flat punch, tapping the upset shaft material flat onto the shaft. For high speed, heavy load (radial or thrust), vibration, eccentric loading, stainless steel or hollow shafting, reduction of fretting, vibration or marking of the shafting, review alternate locks below or consult Application Engineering.



Double Sided (Double Lock) Setscrew Locking System

Double sided setscrew lock is extended on both sides of the inner ring. The inner race is locked to the shaft by four screws. This design is the preferred lock for the heavy duty Sealmaster Gold Mounted Ball Bearings with double lock incorporate the same unique package of locking features included in the single lock design: wide inner ring design, zone hardened inner rings, specially designed setscrews, and 120° setscrew position.

The double lock design is specified for demanding applications or where shaft lock reliability is critical. This design is often specified on high load applications, high thrust load applications, vertical shafts where extra holding power is required, eccentric drive applications, high vibration applications, and high speed applications. It also helps to reduce fretting corrosion on the shaft. Upset setscrew marks on the shaft can be minimized for removal of the bearing by removing the setscrews and, using a flat punch, tapping the upset shaft material flat onto the shaft. For stainless steel shafting, or where vibration reduction is required, refer to Skwezloc[®] or BOA Concentric locking collar below or consult Application Engineering.



Eccentric Locking

Eccentric locking design incorporates a precision eccentric collar that mates with the inner ring extension for shaft hold. The inner ring is extended and has an eccentric profile machined on the outer diameter at the end. The inner diameter of the collar has an eccentric profile machined that mates with the inner ring extension. The eccentric collar is placed on the inner ring extension and rotated in the direction of shaft rotation. This rotation forces the collar and inner ring eccentric profiles to lock by creating a friction grip. The collar makes contact with the shaft and a setscrew on the collar is then tightened to lock the collar in place. This design is available on Browning Mounted Ball Bearings only.

Note: The eccentric is designed for single direction of rotation and should not be used when two direction rotation is present.



Lock Types continued

The Concentric Locking System

Sealmaster Skwezloc® and Browning BOA concentric locking system for ball bearings has an inner ring extension which is slit into 6 tangs. The split concentric collar is tightened over the inner ring extension, gripping the bearing to the shaft. The concentric design friction grips to the shaft with 360° of holding.



- Centers the shaft in the bore of the bearing, reducing vibration and shaft runout.
- Maintains manufactured ball path roundness reducing vibration and enhances bearing life.
- Excellent for high speed applications
- Does not mark the shaft like set screw or eccentric lock.
- Is easy to install, requiring tightening only one Torx head capscrew.

Concentric is often specified in air handling, HVAC, fan and blower applications where noise and vibration reduction is essential. High speed applications such as saws and routers or high speed spindles are common applications for concentric locking. Coating roll and sanding applications are also good applications for the concentric where runout control of the rotating system is essential. Concentric is recommended for stainless steel or hardened shafting. In vertical shaft or high thrust load applications, a thrust collar or axial locating device is required to insure safety of the friction grip lock.

Shaft Lock Comparison				
Characteristic	Single Lock	Double Lock	Concentric	Eccentric
High Speeds	✓✓	✓✓✓	✓✓✓✓	✓✓
Heavy Loads	✓✓	✓✓✓✓	✓✓✓✓	✓
Radial Loads	✓✓✓✓	✓✓✓✓	✓✓✓✓	✓✓✓✓
Thrust Loads	✓✓✓	✓✓✓✓	✓✓*	✓*
Fretting Control	✓✓	✓✓✓	✓✓✓✓	✓✓
Run out Control	✓✓	✓✓	✓✓✓✓	✓✓
Reliability of Lock	✓✓✓	✓✓✓✓	✓✓✓✓	✓✓
Vertical Shaft	✓✓✓	✓✓✓✓	✓✓*	✓*
Eccentric Loads	✓✓	✓✓✓✓	✓✓✓	✓
Hardened/Stainless Shafts	✓✓	✓✓✓	✓✓✓✓✓	✓✓

Legend: Excellent ✓✓✓✓, Good ✓✓✓, Fair ✓✓, Poor ✓
 * Review use of thrust device.

Note: Premium locking systems are not intended to be a fix for worn, damaged or undersized shafting or poor mounting practices. Consult Installation Instructions for proper installation.

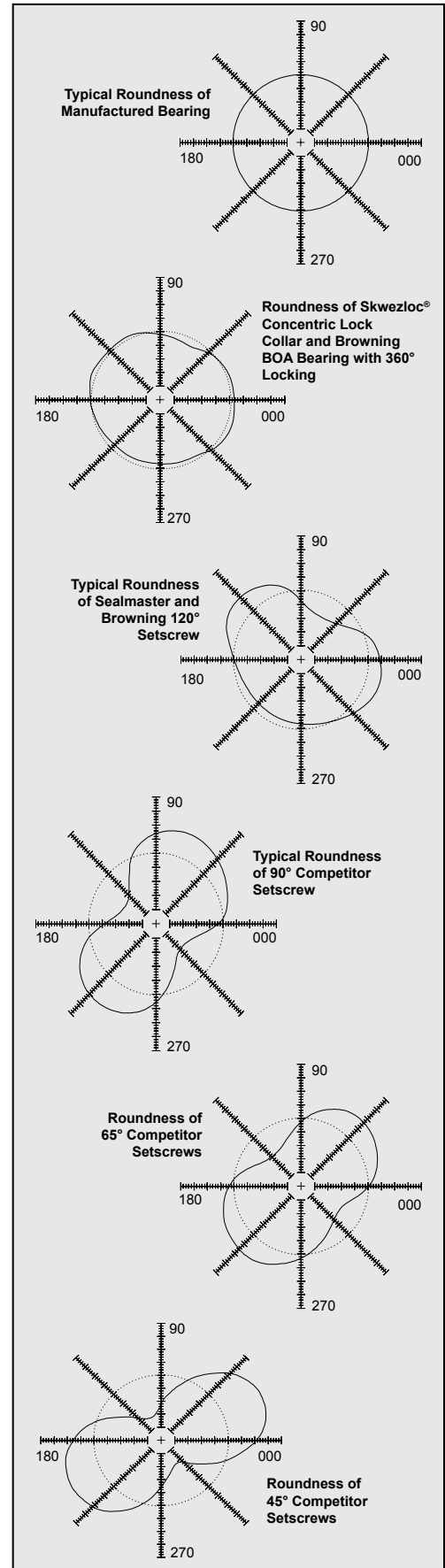



Sealmaster Gold Mounted Ball Bearing Housed Units Installation

NOTICE

- These bearings are designed for maximum permissible static misalignment of ± 2 degrees. Installation, handling or operation of the bearing in excess of the maximum of ± 2 degrees can cause reduction in bearing performance and may lead to equipment failure.

- Do not strike or hammer on any component of the bearing and/or shaft. Impact can result in damage to the bearing that may cause reduction in bearing performance and may lead to equipment failure.



Step 1: Inspect Shaft and Bore

Shaft should be within tolerance range shown in table, clean and free of nicks and burrs. Mount bearings on unused section of shafting or repair/replace shafting as required. Inspect both the shaft and bearing bore for debris or contaminants. Wipe clean as necessary.



SM Gold Table 1

Recommended Shaft Tolerances	
Nominal Bore Diameter	Tolerance (inch)
1/2 - 1 15/16	+0.0000 / -0.0005
2 - 3 3/16	+0.0000 / -0.0010
3 1/4 - 4 15/16	+0.0000 / -0.0015

Step 2: Check Support Surfaces

Make sure the base of the housing and the support surfaces are clean and free from burrs. If the housing elevation is adjusted with shims these must cover the entire contact area between the housing and the support surface.

Step 3: Install Unit

To aid installation, keep weight off bearing during mounting. Slide unit onto shaft by pushing on the inner ring. If it is difficult to mount bearing on shaft, use a piece of emery cloth to reduce any high spots on the shaft.

Step 4: Fasten Unit in Place

Install housing mounting bolts and check bearing alignment. Align the bearing units as closely as possible. Tighten mounting bolts to recommended fastener torques. Check the shaft for freedom of rotation by rotating shaft with hand in both directions.

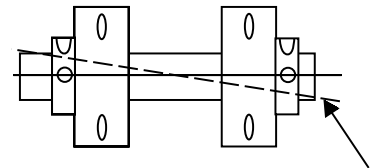

Step 5: Position Insert

If expansion units are used, the insert must be located in the housing to allow for axial shaft expansion and/or contraction. Position bearing insert to obtain the required axial expansion in desired directions. It may be necessary to unload the bearing while moving the assembly.



Sealmaster Gold Mounted Ball Bearing Housed Units Installation continued

Step 6: Tighten Locking Mechanism

a. Setscrew Locking Inserts

Setscrews in multiple bearing applications should be aligned as shown.

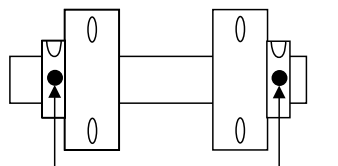

Tighten bearing units to the shaft as follows:

i. Torque the first setscrew "A" to one half of the recommended torque in Table 2.

ii. Torque the second setscrew "B" to the full recommended torque. Go back to the first setscrew "A" and tighten to the full recommended torque.

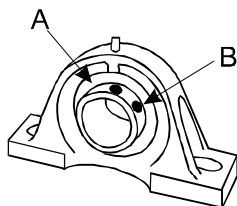

If the bearing unit has setscrew locking on both sides of the inner ring (Double Lock Setscrew), repeat the same procedure for the second pair of setscrews. Check shaft again for freedom of rotation and then tighten the second bearing unit in the same fashion. When all bearings are tightened, perform a final check to the shaft for freedom of rotation.

SM Gold Table 2

Setscrew Torque		
Screw Size	Hex Size	Inch-Pounds
1/4-28	1/8	65 - 85
5/16-24	5/32	125 - 165
3/8-24	3/16	230 - 300
7/16-20	7/32	350 - 450
1/2-20	1/4	500 - 650
5/8-18	5/16	1100 - 1440

b. Skwezloc Locking Inserts

i. Be sure that the Skwezloc collar is fitted square and snug against the shoulder on the inner ring as shown.

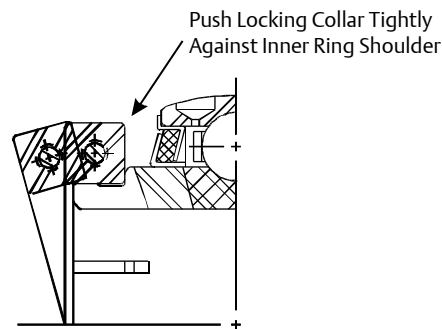

ii. Torque the Skwezloc collar cap screw to the full recommended torque in Table 3.

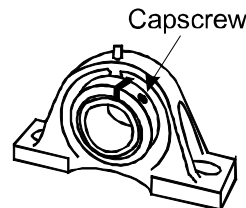

SM Gold Table 3

Skwezloc Concentric Locking Collar Cap Screw Torque		
Screw Size	Torx Size	Inch-Pounds
# 8-32	T-25	70
# 10-24	T-27	100
1/4-20	T-30	240
5/16-18	T-45	495

Check shaft again for freedom of rotation and then tighten the second bearing unit in the same fashion. When all bearings are tightened, perform a final check to the shaft for freedom of rotation.



Mounting Sealmaster Gold Cylindrical O.D. (ER Style) Inserts and Cylindrical O.D. Housings (AR & SC Style):

NOTICE

• Do not strike or hammer on any component of the bearing and/or shaft. Impact can result in damage to the bearing that may cause reduction in bearing performance and may lead to equipment failure.



Step 1: Inspect and Prepare Housing

To achieve proper bearing fit, the housing should be machined to the correct bore size. For recommended housing bore sizes, refer to page G-259. The housing bearing seat should be wiped clean and free of debris.

Step 2: Install Unit in Housing

Press bearing into housing by applying force to the face of the housing, or the face of the outer ring for ER style bearings.

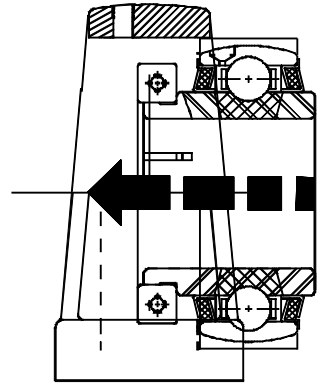

Do not hammer on any component of the bearing or apply force to the inner ring.

Step 3: Refer to Steps 1 - 6 from the "Mounting Housed Bearing Units" Section Pages G-246 to G-247



Sealmaster Gold Expansion Bearings:

Expansion bearings allow for linear shaft expansion or contraction caused by temperature variations. Without this expansion capability, bearings may be subjected to excessive thrust loads and misalignment which could damage the bearing, mounting surfaces, and frameworks. Sealmaster offers two types of expansion (float) bearings:

1. In Sealmaster Gold mounted units where the bearing is installed into an AR ring then into a housing assembly as shown on page G-29. This design allows the bearing to move axially in the housing assembly. Table 4 below shows the allowable expansion by size.

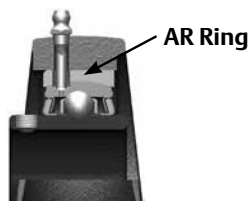

SM Gold Table 4

Bore Diameter		Expansion (inch)
Standard Duty	Medium Duty	
1/2 - 1	N/A	3/32
1 3/16 - 1 3/4	15/16 - 1 1/2	1/8
1 15/16 - 2 15/16	1 11/16 - 2 11/16	3/16
3 - 3 7/16	2 15/16 - 3 3/16	1/4
3 1/2 - 4	3 7/16 - 4	9/32
5	4 7/16 - 4 15/16	7/16

2. In Sealmaster Cylindrical O.D. bearings (ER style) and some Sealmaster Gold mounted units expansion is achieved by utilizing a special half-dog & wire and keyway in the shaft by specifying a "HIY" suffix. The bearing then floats along the shaft. Table 5 shows the shaft slot dimensions required.

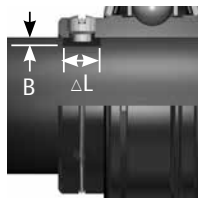

SM Gold Table 5

Bore Sizes	Slot Width (C)	Min. Slot Depth (B)	1/2 Dog Point Dia. (P)
inch	inch	inch	inch
1/2 to 1/4R	13/64	3/32	5/32
1 1/4 to 1 3/4	9/32	3/32	13/64
1 7/8 to 2 7/16	21/64	1/8	1/4
2 1/2 to 3 7/16	21/64	1/8	19/64
3 15/16 to 4	33/64	3/16	15/32

ΔL is calculated below

Notes:

- Before installation, make certain proper expansion is accounted for. Expansion units should be placed in a location where relative movement between the bearing insert and the housing can be tolerated.
- When using an expansion bearing, always use a fixed bearing as the second support bearing.
- Half-dog setscrew and lock wire systems are not recommended for high speed or vibration applications. Application Engineering can be contacted for specifics. Only one half-dog setscrew should be used in this arrangement. No other setscrew should be installed. The half-dog setscrew's nub is engaged within the shaft slot, but not tightened into the shaft.

When shafting is heated, it grows longer. This growth in shaft length is particularly problematic when shafts are long and temperature differentials are large.

The difference in linear expansion between the shaft (shaft length between bearing centers) and the bearing mounting structure must be taken in consideration in high temperature applications. For example, in the case where the shaft, bearings and bearing support structure are all in a heated environment, the effect of thermal expansion on the bearings can be insignificant (assuming that all components are made of steel).

The shaft expansion concern arises when the shaft is in a heated environment but the bearings and bearing support structure are not. In this case the slot length in the shaft should be machined so as to accommodate the amount of linear shaft expansion.

Calculate the minimum slot length (ΔL) as follows:

$$\Delta L = \alpha \cdot X \Delta \text{TEMP}_{\text{sys}}$$

Where:

ΔL = differential linear expansion (inches)

α = coefficient of thermal expansion (inch/inch/°F)

($\alpha = 7 \times 10^{-6}$ inch/inch/°F for most carbon steel shafting)

($\alpha = 1 \times 10^{-5}$ inch/inch/°F for most stainless steel shafting)

X = length of shaft (inches)

$\Delta \text{TEMP}_{\text{sys}}$ = operating shaft temperature (°F) - installed shaft temperature (°F)



Replacing Existing Sealmaster Gold Inserts:

Note: Replacement Sealmaster bearing inserts are intended for use in Sealmaster housings only.

NOTICE

- These bearings are designed for maximum permissible static misalignment of ± 2 degrees. Installation, handling or operation of the bearing in excess of the maximum of ± 2 degrees can cause reduction in bearing performance and may lead to equipment failure.

- Do not strike or hammer on any component of the bearing and/or shaft. Impact can result in damage to the bearing that may cause reduction in bearing performance and may lead to equipment failure.

Step 1: Loosen and Remove Housing Mounting Bolts

Step 2: Remove Bearing from Shaft

Loosen the locking mechanism and slide the bearing off the shaft.

Step 3: Remove the Bearing Insert from the Housing

Secure housing in a vise. Remove lubrication fitting and lock pin from the housing. Do not discard the lubrication fitting or lock pin. Remove insert from housing in the following fashion:

a. For Spherical OD Inserts:

Using a bar placed in the insert bore as a lever, swing the insert to line up the outer ring with the load slots and remove insert from load slots.

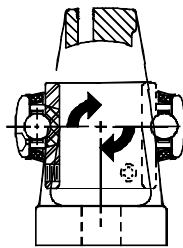

b. For Expansion (AR) Inserts:

Slide the insert in the axial direction out of the housing.

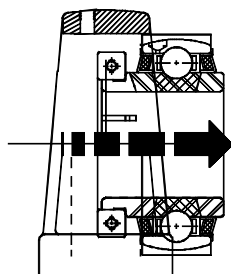

Step 4: Inspect and Prepare Housing

Housings should be inspected for damage prior to installation. Wipe housing bore clean as necessary and check that the lubrication hole is clean and free of debris. Wetting of the housing bore with oil or grease may be done to ease installation of bearing insert.

Step 5: Load New Insert

With the bearing housing still in the vise, load the insert in the following fashion:

a. For Spherical OD Inserts:

i. Place the bearing insert into the housing load slots, positioning the insert outer ring dimple and lubrication hole in line with the housing lubrication hole.

ii. Using a bar placed in the insert bore as a lever, swing the insert into place within the housing. Insert should have a snug fit in the housing. If insert can be made to swivel by hand in the housing bore, fit is too loose and entire unit should be replaced. If heavy force is required, fit is too tight and entire unit should be replaced.

iii. Ensure alignment of the outer ring dimple and lubrication hole and housing lubrication hole.

b. For Expansion (AR) Inserts

i. Slide bearing insert into the housing.

ii. Ensure alignment of the outer ring dimple and lubrication hole, brass ring lubrication hole, and housing lubrication hole.

Step 6: Install Lock Pin and Lubrication Fitting

Place the lock pin in the housing lubrication hole, ensuring that it seats in the outer ring dimple. Tighten the lubrication fitting into the housing lubrication hole until snug, then loosen $\frac{1}{4}$ turn.

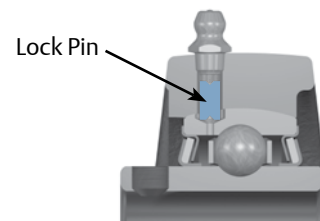

NOTICE:

Over tightening or under tightening of the lubrication fitting may lead to reduction in bearing performance.

Step 7: Refer to Steps 1 - 6 from the "Mounting Housed Bearing Units" Section Pages G-246 to G-247

Sealmaster Material Handling Mounted Ball Bearing Housed Units

NOTICE

• These bearings are designed for maximum permissible static misalignment of $\pm 1\ 1/2$ degrees. Installation, handling or operation of the bearing in excess of the maximum of $\pm 1\ 1/2$ degrees can cause reduction in bearing performance and may lead to equipment failure.

• Do not strike or hammer on any component of the bearing and/or shaft. Impact can result in damage to the bearing that may cause reduction in bearing performance and may lead to equipment failure.



Step 1: Inspect Shaft and Bore

Shaft should be within tolerance range shown in the table, clean and free of nicks and burrs. Mount bearings on unused section of shafting or repair/replace shafting as required. Inspect both the shaft and bearing bore for debris or contaminants. Wipe clean as necessary.

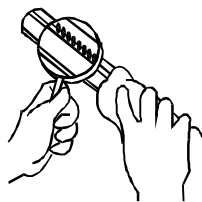

SM MH Table 1

Recommended Shaft Tolerances	
Nominal Bore Diameter	Tolerance (inch)
1/2 - 1 15/16	+0.0000 / -0.0005
2 - 3 3/16	+0.0000 / -0.0010

Step 2: Check Support Surfaces

Make sure the base of the housing and the support surfaces are clean and free from burrs. If the housing elevation is adjusted with shims these must cover the entire contact area between the housing and the support surface.

Step 3: Install Unit

To aid installation, keep weight off bearing during mounting. Slide unit onto shaft by pushing on the inner ring. If it is difficult to mount bearing on shaft, use a piece of emery cloth to reduce any high spots on the shaft.

Step 4: Fasten Unit in Place

Install housing mounting bolts and check bearing alignment. Align the bearing units as closely as possible. Tighten mounting bolts to recommended fastener torques. Check the shaft for freedom of rotation by rotating shaft with hand in both directions.

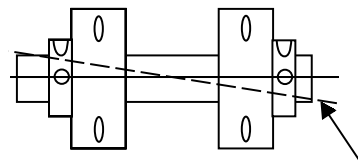



Sealmaster Material Handling Mounted Ball Bearing Housed Units continued

Step 6: Tighten Locking Mechanism

a. Setscrew Locking Inserts

Setscrews in multiple bearing applications should be aligned as shown.

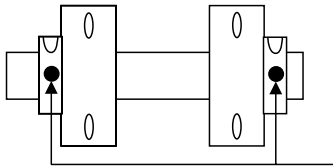

Tighten bearing units to the shaft as follows:

- i. Torque the first setscrew "A" to one half of the recommended torque in Table 2.
- ii. Torque the second setscrew "B" to the full recommended torque. Go back to the first setscrew "A" and tighten to the full recommended torque.

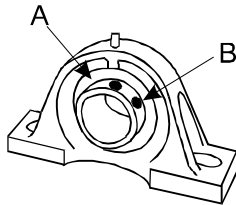

If the bearing unit has setscrew locking on both sides of the inner ring (Double Lock Setscrew), repeat the same procedure for the second pair of setscrews. Check shaft again for freedom of rotation and then tighten the second bearing unit in the same fashion. When all bearings are tightened, perform a final check to the shaft for freedom of rotation.

SM MH Table 2

Setscrew Torque		
Screw Size	Hex Size	Inch-Pounds
1/4-28	1/8	65 - 85
5/16-24	5/32	125 - 165
3/8-24	3/16	230 - 300

b. Skwezloc Locking Inserts

- i. Be sure that the Skwezloc collar is fitted square and snug against the shoulder on the inner ring as shown.
- ii. Torque the Skwezloc collar cap screw to the full recom-

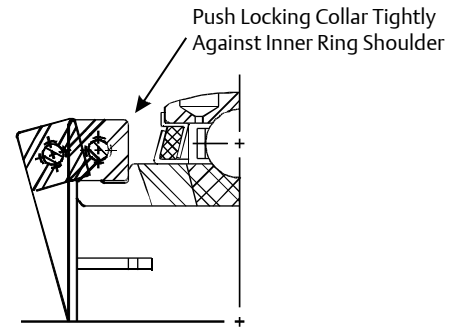

mended torque in Table 3.

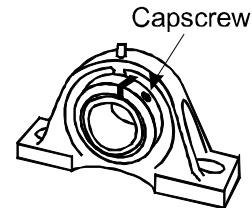

SM MH Table 3

Skwezloc Concentric Locking Collar Cap Screw Torque		
Screw Size	Torx Size	Inch-Pounds
# 8-32	T-25	70
# 10-24	T-27	100
1/4-20	T-30	240

Check shaft again for freedom of rotation and then tighten the second bearing unit in the same fashion. When all bearings are tightened, perform a final check to the shaft for freedom of rotation.

Step 7: End Cover Installation

Position the cap so it is flush with the housing, and align the removal nub in the 12 o'clock position. Press evenly on end of cap by hand to install in the machined housing groove.



Replacing Existing Sealmaster Material Handling Inserts:

Note: Replacement Sealmaster bearing inserts are intended for use in Sealmaster housings only.

NOTICE

- These bearings are designed for maximum permissible static misalignment of $\pm 1\ 1/2$ degrees. Installation, handling or operation of the bearing in excess of the maximum of $\pm 1\ 1/2$ degrees can cause reduction in bearing performance and may lead to equipment failure.

- Do not strike or hammer on any component of the bearing and/or shaft. Impact can result in damage to the bearing that may cause reduction in bearing performance and may lead to equipment failure.

Step 1: Loosen and Remove Housing Mounting Bolts

Step 2: Remove Bearing from Shaft

Remove the end cover. Loosen the locking mechanism and slide the bearing off the shaft.

Step 3: Remove the Bearing Insert from the Housing

Secure housing in a vise. Using a bar placed in the insert bore as a lever, swing the insert to line up the outer ring with the load slots and remove insert from load slots.

Step 4: Inspect and Prepare Housing

Housings should be inspected for damage prior to installation. Wipe housing bore clean as necessary and check that the lubrication groove and hole are clean and free of debris. Wetting of the housing bore with oil or grease may be done to ease installation of bearing insert.

Step 5: Load New Insert

With the bearing housing still in the vise, load the insert in the following fashion:

a. Place the bearing insert into the housing load slots, positioning the anti rotation rivet on the outer ring in the load slot as to not shear it off when the swinging insert into place. Also, position the outer ring lubrication hole so it will install in line with the housing lubrication hole.

b. Using a bar placed in the insert bore as a lever, swing the insert into place within the housing. Insert should have a snug fit in the housing. If insert can be made to swivel by hand in the housing bore, fit is too loose and entire unit should be replaced. If heavy force is required, fit is too tight and entire unit should be replaced.

c. Ensure alignment of the anti rotation rivet in the load slot and outer ring lubrication hole in the housing lubrication hole.

Step 6: Refer to Steps 1 - 6 from the "Mounting Housed Bearing Units" Section Pages G-251 to G-252



Sealmaster Gold and Material Handling Bearing Lubrication:

All Sealmaster Gold and Material Handling Ball Bearings are delivered with a high quality lithium complex grease with an EP additive. The bearing is ready for use with no initial lubrication required. The grease consists of a lithium complex thickener, mineral oil, and NLGI grade 2 consistency. Compatibility of grease is critical; therefore consult with Application Engineering and your grease supplier to insure greases are compatible. For best performance it is recommended to relubricate with lithium complex thickened grease with a comparable NLGI consistency and base oil properties.

Relubricatable Sealmaster bearings are supplied with grease fittings or zerks for ease of lubrication with hand or automatic grease guns. Always wipe the fitting and grease nozzle clean.

Note: Sealmaster bearings with the RM suffix are Reduced Maintenance Bearings (ex. NP-16 RM). Sealmaster Reduced Maintenance Bearings are designed to operate with the standard factory fill of grease and are designed not to be lubricated.

CAUTION: If possible, it is recommended to lubricate the bearing while rotating, until grease purge is seen from the seals. If this is not an option due to safety reasons, follow the alternate lubrication procedure below.

Re-Lubrication Procedure:

Stop rotating equipment. Add one half of the recommended amount shown in Table 1. Start the bearing and run for a few minutes. Stop the bearing and add the second half of the recommended amount. A temperature rise after lubrication, sometimes 30°F (17°C), is normal. Bearing should operate at temperatures less than 200°F (94°C) and should not exceed 250° (121°C) for intermittent operation. For lubrication guidelines, see Tables 2 and 3.

Note: Tables 2 and 3 are general recommendations. Experience and testing may be required for specific applications.

Note: Grease charges in Table 1 are based on the use of lithium complex thickened grease with a NLGI grade 2 consistency.

Note: The Maximum Operational Speeds listed in Table 2 and 3 are based on the use of a single lock setscrew insert with felt seals. For maximum operational speeds of other locking mechanisms and seals, refer to speed rating section or consult Application Engineering.

LO and XLO Relubrication Frequency

LO and XLO bearings are designed for applications which require the bearing to operate with less torque or drag than a standard bearing.

Note: Addition of lubricant to the bearing will increase bearing drag.

If relubrication is necessary:

1. Add a very small amount of lubricant
2. Check bearing rotational torque (be sure that the bearing still rotates freely enough for the application.)

Sealmaster Ball Lube Table 1 / Grease Charge for Relubrication

Series	Bore Diameter		Grease Charge (Mass - Ounces)	Bore Diameter Material Handling Bearing	Grease Charge (Mass - Ounces)
	Gold - Performance				
	Standard Duty	Medium Duty			
2-012	1/2 - 3/4	-	0.03	-	-
2-015	13/16 - 1	-	0.04	1	0.03
2-13	1 1/16 - 1 1/4R	15/16 - 1	0.09	1 1/16 - 1 1/4R	0.06
2-17	1 1/4 - 1 7/16	1 3/16	0.13	1 1/4 - 1 7/16	0.09
2-19	1 1/2 - 1 9/16	1 7/16	0.18	1 1/2 - 1 9/16	0.14
2-111	1 5/8 - 1 3/4	1 1/2	0.20	1 5/8 - 1 3/4	0.16
2-115	1 13/16 - 2R	1 11/16 - 1 3/4	0.22	1 13/16 - 2R	0.18
2-23	2 - 2 3/16	1 15/16	0.30	2 - 2 3/16	0.25
2-27	2 1/4 - 2 7/16	2 3/16	0.38	-	-
2-211	2 1/2 - 2 11/16	2 7/16 - 2 1/2	0.53	-	-
2-215	2 13/16 - 2 15/16	2 11/16	0.62	-	-
2-33	3 - 3 3/16	2 15/16	0.88	-	-
2-37	3 1/4 - 3 7/16	3 3/16	1.11	-	-
2-38	3 1/2	3 7/16	1.37	-	-
2-43	3 15/16 - 4 3/16	3 15/16 - 4	2.50	-	-
2-47	5	4 7/16 - 4 15/16	3.91	-	-

Sealmaster Relubrication Frequency

Sealmaster Ball Lube Table 2

Environment	Temperature (°F)	Speed (% Catalog Max)	Frequency
Dirty	-20 to 250	0 - 100%	Daily to 1 Week
		0 - 25%	4 to 10 Months
Clean	-20 to 125	26 - 50%	1 to 4 Months
		51 - 75%	1 Week to 1 Month
		76 - 100%	Daily to 1 Week
		0 - 25%	2 to 6 Weeks
	125 to 175	26 - 50%	1 Week to 1 Month
		51 - 75%	Daily to 1 Week
		76 - 100%	
	175 to 250	0 - 100%	

Sealmaster High Temperature Suffix Modified Bearing Relubrication Frequency

Sealmaster Ball Lube Table 3

Environment	Temperature (°F)	Speed (% Catalog Max)	HT / HTC / HTA Suffix (1)	HI Suffix (2)
Dirty	-20 to 400	0 - 100%	Daily to 1 Week	Daily to 1 Week
		0 - 25%	1 to 3 Months	6 to 12 Months
Clean	200 to 300	26 - 50%	2 to 6 Weeks	2 to 6 Months
		51 - 75%	Daily to 1 Week	2 Weeks to 2 Months
		76 - 100%	Daily to 1 Week	Daily to 1 Week
		0 - 25%	2 Weeks to 1 Month	3 to 6 Months
	300 to 400	26 - 50%	1 to 2 Weeks	1 to 3 Months
		51 - 75%	Daily to 1 Week	1 Week to 1 Month
		76 - 100%	Daily to 1 Week	Daily to 1 Week
		0 - 25%	Daily to 1 Week	Daily to 1 Week

(1) Use high quality lithium complex grease, NLGI#2 and synthetic hydrocarbon oil with ISO 220 viscosity

(2) Use Krytox GPL-226, no substitutions

*DuPont is a registered trademark of E.I. du Pont de Nemours and Company. This trade name, trademark and/or registered trademark is property of their respective owner and is not owned or controlled by Power Transmission Solutions.

Browning Mounted Ball Bearing Housed Units

NOTICE

• These bearings are designed for maximum permissible static misalignment of $\pm 1\ 1/2$ degrees. Installation, handling or operation of the bearing in excess of the maximum of $\pm 1\ 1/2$ degrees can cause reduction in bearing performance and may lead to equipment failure.

• Do not strike or hammer on any component of the bearing and/or shaft. Impact can result in damage to the bearing that may cause reduction in bearing performance and may lead to equipment failure.



Step 1: Inspect Shaft and Bore

Shaft should be within tolerance range shown in the table, clean and free of nicks and burrs. Mount bearings on unused section of shafting or repair/replace shafting as required. Inspect both the shaft and bearing bore for debris or contaminants. Wipe clean as necessary.

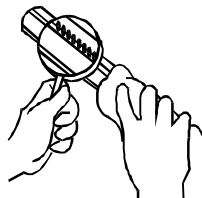

SM Gold Table 1

Recommended Shaft Tolerances	
Nominal Bore Diameter	Tolerance (Inches)
1/2 - 1 15/16	+0.0000 / -0.0005
2 - 2 7/16	+0.0000 / -0.0010

Step 2: Check Support Surfaces

Make sure the base of the housing and the support surfaces are clean and free from burrs. If the housing elevation is adjusted with shims these must cover the entire contact area between the housing and the support surface.

Step 3: Install Unit

To aid installation, keep weight off bearing during mounting. Slide unit onto shaft by pushing on the inner ring. If it is difficult to mount bearing on shaft, use a piece of emery cloth to reduce any high spots on the shaft.

Step 4: Fasten Unit in Place

Install housing mounting bolts and check bearing alignment. Align the bearing units as closely as possible. Tighten mounting bolts to recommended fastener torques. Check the shaft for freedom of rotation by rotating shaft with hand in both directions.

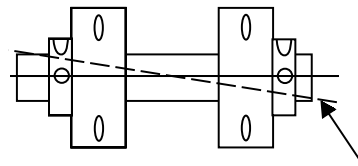



Browning Mounted Ball Bearing Housed Units continued

Step 5: Tighten Locking Mechanism

a. Setscrew Locking Inserts

Setscrews in multiple bearing applications should be aligned as shown.

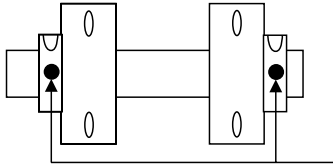

Tighten bearing units to the shaft as follows:

- i. Torque the first setscrew "A" to one half of the recommended torque in Table 2.
- ii. Torque the second setscrew "B" to the full recommended torque. Go back to the first setscrew "A" and tighten to the full recommended torque.

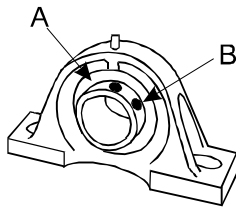

BMD Table 2

Setscrew Recommended Torque		
Screw Size	Hex Size	Inch-Pounds
1/4-28	1/8	65 - 85
5/16-24	5/32	125 - 165
3/8-24	3/16	230 - 300
7/16-20	7/32	350 - 450
1/2-20	1/4	500 - 650
5/8-18	5/16	1100 - 1440

b. Eccentric Locking Inserts

- i. Place collar on inner race and rotate by hand in direction of shaft rotation until eccentrics are engaged.
- ii. Insert drift pin into the hole in the collar O.D. (B) and lock in direction of shaft rotation with the aid of small hammer.
- iii. Torque single setscrew (A) to recommended torque in Table 3.

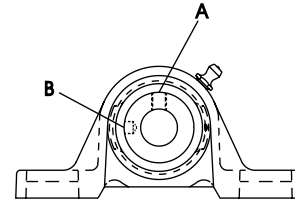

BMD Table 3

Eccentric Locking Recommended Torque		
Screw Size	Hex Size	Inch-Pounds
1/4-28	1/8	65 - 85
5/16-24	5/32	125 - 165
3/8-24	3/16	230 - 300
7/16-20	7/32	350 - 450
1/2-20	1/4	500 - 650
5/8-18	5/16	1100 - 1440

c. BOA Locking Inserts

- i. Be sure that the BOA collar is fitted square and snug against the shoulder on the inner ring as shown.

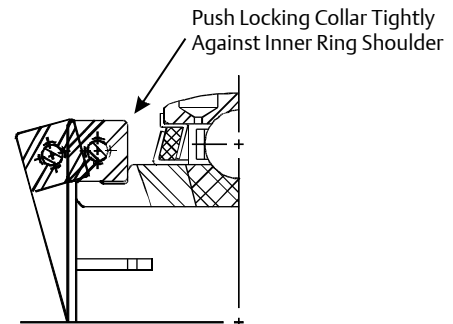

- ii. Torque the BOA collar cap screw to the full recommended torque in Table 4.

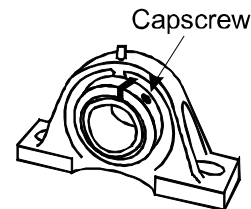

BMD Table 4

BOA Concentric Locking Collar Cap Screw Torque		
Screw Size	Torx Size	Inch-Pounds
# 8-32	T-25	70
# 10-24	T-27	100
1/4-20	T-30	240
5/16-18	T-45	495

Check shaft again for freedom of rotation and then tighten the second bearing unit in the same fashion. When all bearings are tightened, perform a final check to the shaft for freedom of rotation.

Mounting Cylindrical O.D. (VER Style) Inserts:

Step 1: Inspect and Prepare Housing

To achieve proper bearing fit, the housing should be machined to the correct bore size. For recommended housing bore sizes, refer to the Browning bearing catalog or consult Application Engineering. The housing bearing seat should be wiped clean and free of debris.

Step 2: Install Unit in Housing

Press bearing into housing by applying force to the face of the outer ring. Do not hammer on any component of the bearing or apply force to the inner ring.

Step 3: Refer to Steps 1 - 5 from the "Mounting Housed Bearing Units" Section Pages G-255 to G-256

Replacing Existing Browning Inserts:

Note: Replacement Browning bearing inserts are intended for use in Browning housings only.

Step 1: Loosen and Remove Housing Mounting Bolts

Step 2: Remove Bearing from Shaft

Loosen the locking mechanism and slide the bearing off the shaft.

Step 3: Remove the Bearing Insert from the Housing

Secure housing in a vise. Using a bar placed in the insert bore as a lever, swing the insert to line up the outer ring with the load slots and remove insert from load slots.

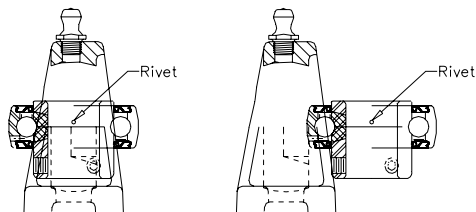

Step 4: Inspect and Prepare Housing

Housings should be inspected for damage prior to installation. Wipe housing bore clean as necessary and check that the lubrication groove and hole are clean and free of debris. Wetting of the housing bore with oil or grease may be done to ease installation of bearing insert.

Step 5: Load New Insert

With the bearing housing still in the vise, load the insert in the following fashion:

- a. Place the bearing insert into the housing load slots, positioning the anti rotation rivet on the outer ring in the load slot as to not shear it off when the swinging insert into place. Also, position the outer ring lubrication hole so it will install in line with the housing lubrication hole.

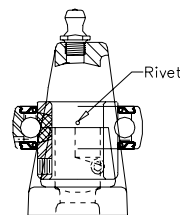

- b. Using a bar placed in the insert bore as a lever, swing the insert into place within the housing. Insert should have a snug fit in the housing. If insert can be made to swivel by hand in the housing bore, fit is too loose and entire unit should be replaced. If heavy force is required, fit is too tight and entire unit should be replaced.

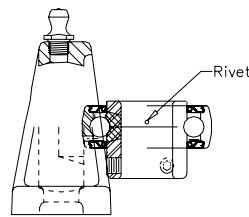

- c. Ensure alignment of the anti rotation rivet in the load slot and outer ring lubrication hole in the housing lubrication hole.

Step 6: Refer to Steps 1 - 5 from the "Mounting Housed Bearing Units" Section Pages G-255 to G-256



Browning Mounted Ball Lubrication:

All Browning Ball Bearings are delivered with a high quality lithium complex grease with an EP additive. The bearing is ready for use with no initial lubrication required. The grease consists of a lithium complex thickener, mineral oil, and NLGI grade 2 consistency.

Compatibility of grease is critical; therefore consult with Application Engineering and your grease supplier to insure greases are compatible. For best performance it is recommended to relubricate with lithium complex thickened grease with a comparable NLGI consistency and base oil properties.

Relubricatable Browning bearings are supplied with grease fittings or zerks for ease of lubrication with hand or automatic grease guns. Always wipe the fitting and grease nozzle clean.

CAUTION: If possible, it is recommended to lubricate the bearing while rotating, until grease purge is seen from the seals. If this is not an option due to safety reasons, follow the alternate lubrication procedure below.

Re-Lubrication Procedure:

Stop rotating equipment. Add one half of the recommended amount shown in Table 1. Start the bearing and run for a few minutes. Stop the bearing and add the second half of the recommended amount. A temperature rise after lubrication, sometimes 30°F (17°C), is normal. Bearing should operate at temperatures less than 200°F (94°C) and should not exceed 250° (121°C) for intermittent operation. For lubrication guidelines, see Table 2.

Note: Table 2 is general recommendations. Experience and testing may be required for specific applications.

Note: Grease charges in Table 1 are based on the use of lithium complex thickened grease with a NLGI grade 2 consistency.

**Browning Lube Table 1
Grease Charge for Relubrication**

Series	Shaft Size		Grease Charge (Mass - Ounces)
	100 & 200 Series	300 Series	
	Intermediate & Standard Duty	Medium Duty	
L-10	1/2 - 5/8	x	0.02
2-012	3/4	x	0.03
2-015	13/16 - 1	x	0.03
2-13	1 1/16 - 1 1/4S	15/16 - 1	0.06
2-17	1 1/4 - 1 7/16	1 3/16	0.09
2-19	1 1/2 - 1 9/16	1 7/16	0.14
2-111	1 5/8 - 1 3/4	1 1/2	0.16
2-115	1 13/16 - 2S	1 11/16 - 1 3/4	0.18
2-23	2 - 2 3/16	1 15/16	0.25
2-27	2 1/4 - 2 7/16	2 3/16	0.35
2-211	2 1/2 - 2 11/16	2 7/16 - 2 1/2	0.46
2-215	2 13/16 - 2 15/16	2 11/16	0.48
2-33	x	2 15/16 - 3	0.65
2-38	x	3 7/16 - 3 1/2	1.05
2-43	x	3 15/16	1.77

**Browning Lube Table 2
Relubrication Recommendations**

Environment	Temperature (°F)	Speed (% Catalog Max)	Frequency
Dirty	-20 to 250	0 - 100%	Daily to 1 Week
		0 - 25%	4 to 10 Months
Clean	-20 to 125	26 - 50%	1 to 4 Months
		51 - 75%	1 Week to 1 Month
		76 - 100%	Daily to 1 Week
		0 - 25%	2 to 6 Weeks
	125 to 175	26 - 50%	1 Week to 1 Month
		51 - 75%	Daily to 1 Week
		76 - 100%	
	175 to 250	0 - 100%	Daily to 1 Week

Cylindrical OD Housing Fit Guidelines

Tables 14-15 list fit up guidelines for light load conveyor roll application per ABMA J6 fit. Testing and experience is needed to verify if this fit is sufficient for specific operation conditions. If tighter press fit is needed, contact Application Engineering to review if the standard bearing internal clearance is sufficient or a modified clearance is needed to prevent reduction or elimination of internal clearance.

For best reliability, bearings and housings should be selectively matched to reduce variation in fit up due to manufacturing tolerances of the bearing outside diameter and housing bore. Roll pockets should be machined parallel with the axis of the shaft and both sides should be on the same centerline to minimize potential for misalignment.

Table 14 - ER, VER and Cylindrical OD Insert Bearing Housing/Roll Bore

Bore Diameter		Sealmaster ER	Browning VER	Nominal Outside Diameter	Dimensions inch / mm									
					Outside Diameter*		Stationary Housing				Revolving Housing			
							Diameters		Theoretical Fit		Diameters		Theoretical Fit	
inch	mm	Max	Min	Max	Min	Tight	Loose	Max	Min	Tight	Loose			
1/2	-	ER-8	VER-208	1.8504 47	1.8504 47.002	1.8499 46.9875	1.8509 47.0129	1.8503 46.9976	.0001 .0025	.0010 .0254	1.8504 47.002	1.8498 46.9848	.0006 .0152	.0005 .0127
9/16	-	ER-9	-											
5/8	-	ER-10	VER-210											
11/16	-	ER-11	-											
3/4	-	ER-12	VER-212											
-	20	ER-204	-	2.0472 52	2.0472 51.9989	2.0466 51.9836	2.0476 52.0090	2.0471 51.9963	.0001 .0025	.0010 .0254	2.0471 51.9963	2.0466 51.9836	.0006 .0152	.0005 .0127
7/8	-	ER-14	VER-214											
15/16	-	ER-15	VER-215											
1	-	ER-16	VER-216											
-	25	ER-205	-											
1 1/16	-	ER-17	VER-217	2.4409 62	2.4409 61.9989	2.4403 61.9836	2.4413 62.0090	2.4408 61.9963	.0001 .0025	.0010 .0254	2.4408 61.9963	2.4403 61.9836	.0006 .0152	.0005 .0127
1 1/8	-	ER-18	VER-218											
1 3/16	-	ER-19	VER-219											
1 1/4	-	ER-20R	VER-220S											
-	30	ER-206	-											
1 1/4	-	ER-20	VER-220	2.8364 72	2.8346 71.9988	2.8340 71.9836	2.8350 72.0090	2.8345 71.9963	.0001 .0025	.0010 .0254	2.8345 71.9963	2.8340 71.9836	.0006 .0152	.0005 .0127
1 5/16	-	ER-21	-											
1 3/8	-	ER-22	VER-222											
1 7/16	-	ER-23	VER-223											
-	35	ER-207	-											
1 1/2	-	ER-24	VER-224	3.1496 80	3.1496 79.9998	3.1490 79.9846	3.1500 80.0100	3.1495 79.9973	.0001 .0025	.0010 .0254	3.1495 79.9973	3.1490 79.9846	.0006 .0152	.0005 .0127
1 9/16	-	ER-25	VER-225											
-	40	ER-208	-											
1 5/8	-	ER-26	VER-226	3.3465 85	3.3465 85.0011	3.3459 84.9808	3.3470 85.0138	3.3464 84.9986	.0001 .0025	.0013 .0330	3.3464 84.9986	3.3458 84.9833	.0007 .0178	.0007 .0178
1 11/16	-	ER-27	VER-227											
1 3/4	-	ER-28	VER-228											
-	45	ER-209	-											

This chart displays the recommended housing dimensions for Sealmaster ER and Browning VER ball bearings at the various bore diameters and nominal Outer Diameter. For Sealmaster ER with Skwezloc Concentric locking use the similar size ER with setscrew locking as shown. For other Browning Cylindrical O.D. bearings use the similar nominal dimensioned bearing.

* Outside diameter may be slightly oversized due to seal press fit, dimensions listed are as measured prior to seal assembly.



Table 14 - ER, VER and Cylindrical OD Insert Bearing Housing/Roll Bore cont.

Bore Diameter		Sealmaster ER	Browning VER	Nominal Outside Diameter	Dimensions inch / mm									
					Outside Diameter*		Stationary Housing				Revolving Housing			
							Diameters		Theoretical Fit		Diameters		Theoretical Fit	
inch	mm	Max	Min	Max	Min	Tight	Loose	Max	Min	Tight	Loose			
1 13/16	-	ER-29	-	3.5433 90	3.5433 89.998	3.5425 89.9795	3.5438 90.0125	3.5432 89.9972	.0001 .0025	.0013 .0330	3.5432 89.9973	3.5426 89.9820	.0007 .0178	.0007 .0178
1 7/8	-	ER-30	-											
1 15/16	-	ER-31	VER-231											
2	-	ER-32R	VER-232S											
-	50	ER-210	-											
2	-	ER-32	VER-232	3.937	3.9370	3.9362	3.9375	3.9369	.0001 .0025	.0013 .0330	3.9369 99.9973	3.9363 99.9820	.0007 .0178	.0007 .0178
2 1/8	-	ER-34	-											
2 3/16	-	ER-35	VER-235											
-	55	ER-211	-											
2 1/4	-	ER-36	VER-236	4.3307	4.3307	4.3299	4.3312	4.3306	.0001 .0025	.0013 .0330	4.3306 109.9972	4.3300 109.9820	.0007 .0178	.0007 .0178
2 3/8	-	ER-38	VER-238											
2 7/16	-	ER-39	VER-239											
-	60	ER-212	-											
2 1/2	-	ER-40	-	4.9213 125	4.9213 125.0010	4.9203 124.9756	4.9219 125.0163	4.9211 124.9959	.0002 .0051	.0016 .0406	4.9212 124.9985	4.9204 124.9782	.0009 .0229	.0009 .0229
2 11/16	-	ER-43	-											
-	70	ER-214	-											
2 7/8	-	ER-46	-											
2 15/16	-	ER-47	-	5.1181 130	5.1181 129.9997	5.1171 129.9743	5.1187 130.0150	5.1179 129.9947	.0002 .0051	.0016 .0406	5.1180 129.9972	5.1172 129.9769	.0009 .0229	.0009 .0229
-	75	ER-215	-											
3	-	ER-48	-											
3 3/16	-	ER-51	-	5.5118 140	5.5118 139.9997	5.5108 139.9743	5.5124 140.0150	5.5116 139.9946	.0002 .0051	.0016 .0406	5.5117 139.9972	5.5109 139.9769	.0009 .0229	.0009 .0229
-	80	ER-216	-											
3 1/4	-	ER-52	-											
3 3/8	-	ER-54	-	5.9055 150	5.9055 148.9997	5.9045 149.9743	5.9061 150.0149	5.9053 149.9946	.0002 .0051	.0016 .0406	5.9054 149.9972	5.9046 149.9768	.0009 .0229	.0009 .0229
3 7/16	-	ER-55	-											
3 15/16	-	ER-63	-	7.4803 190	7.4803 189.9996	7.4791 189.9691	7.4815 190.0301	7.4801 189.9945	.0002 .0051	.0024 .0610	7.4805 190.0047	7.4791 189.9691	.0012 .0305	.0014 .0356
4	-	ER-64	-											

This chart displays the recommended housing dimensions for Sealmaster ER and Browning VER ball bearings at the various bore diameters and nominal Outer Diameter. For Sealmaster ER with Skwezloc Concentric locking use the similar size ER with setscrew locking as shown. For other Browning Cylindrical O.D. bearings use the similar nominal dimensioned bearing.

* Outside diameter may be slightly oversized due to seal press fit, dimensions listed are as measured prior to seal assembly.

Table 15 - Sealmaster SC and MSC Housing Bore

Standard Duty		Part No.	Medium Duty		Part No.	Nominal Outside Diameter	Housing Dimension Recommendations inch/mm						
Bore Diameter			Bore Diameter				inch mm	Outside Diameter		Stationary Housing		Revolving Housing	
inch	mm	inch	mm	Max	Min	Max		Min	Max	Min			
1/2	-	SC-8	-	-	-	2 11/16 68.26	2.6885	2.6865	2.6905	2.6885	2.6875	2.6855	
9/16	-	SC-9	-	-	-		68.288	68.237	68.339	68.288	68.263	68.212	
5/8	-	SC-10	-	-	-		2 15/16 74.61	2.9385	2.9365	2.9405	2.9385	2.9375	2.9355
11/16	-	SC-11	-	-	-	74.638		74.587	74.689	74.638	74.613	74.562	
3/4	-	SC-12	-	-	-	3 1/8 79.38	3.1260	3.1240	3.1280	3.1260	3.1250	3.1230	
-	20	SC-204	-	-	-		79.400	79.350	79.451	79.400	79.375	79.324	
13/16	-	SC-13	-	-	-		3 1/2 88.90	3.5010	3.4990	3.5030	3.5010	3.5000	3.4980
7/8	-	SC-14	-	-	-			88.925	88.875	88.976	88.925	88.900	88.849
15/16	-	SC-15	-	-	-	3 7/8 98.43		3.8760	3.8740	3.8780	3.8760	3.8750	3.8730
1	-	SC-16	-	-	-		98.450	98.400	98.501	98.450	98.425	98.374	
-	25	SC-205	-	-	-		4 3/16 106.36	4.1885	4.1865	4.1905	4.1885	4.1875	4.1855
1 1/16	-	SC-17	-	-	-			106.388	106.337	106.439	106.388	106.363	106.312
1 1/8	-	SC-18	15/16	-	MSC-15	4 3/8 111.13		4.3760	4.3740	4.3780	4.3760	4.3750	4.3730
1 3/16	-	SC-19	1	-	MSC-16		111.150	111.100	111.201	111.150	111.125	111.074	
1 1/4	-	SC-20R	-	25	MSC-305		4 9/16 115.89	4.5635	4.5615	4.5655	4.5635	4.5625	4.5605
-	30	SC-206	-	-	-			115.913	115.862	115.964	115.913	115.888	115.837
1 1/4	-	SC-20	-	-	-	1 13/16		-	-	-	-	-	-
1 5/16	-	SC-21	1 3/16	-	MSC-19		1 7/8	-	-	-	-	-	
1 3/8	-	SC-22	1 1/4	-	MSC-20		1 15/16	-	-	-	-	-	
1 7/16	-	SC-23	-	30	MSC-306		2	-	-	-	-	-	
-	35	SC-207	-	-	-	1 15/16	-	-	-	-	-	-	
1 1/2	-	SC-24	1 3/8	-	MSC-22		1 7/8	-	-	-	-	-	
1 9/16	-	SC-25	1 7/16	-	MSC-23		1 15/16	-	-	-	-	-	
-	40	SC-208	-	35	MSC-307	2	-	-	-	-	-		
1 5/8	-	SC-26	-	-	-	1 15/16	-	-	-	-	-	-	
1 11/16	-	SC-27	1 1/2	-	MSC-24		1 7/8	-	-	-	-	-	
1 3/4	-	SC-28	-	40	MSC-308		1 15/16	-	-	-	-	-	
-	45	SC-209	-	-	-	2	-	-	-	-	-	-	
1 13/16	-	SC-29	-	-	-		1 7/8	-	-	-	-	-	
1 7/8	-	SC-30	1 11/16	-	MSC-27		1 15/16	-	-	-	-	-	
1 15/16	-	SC-31	1 3/4	-	MSC-28		2	-	-	-	-	-	
-	50	SC-210	-	-	-	2	-	-	-	-	-	-	
-	-	SC-32R	-	45	MSC-309		-	-	-	-	-	-	

This chart displays the recommended housing dimensions for Sealmaster SC and MSC ball bearings at the various bore diameters and nominal Outer Diameter. For Sealmaster SC and MSC with Skwezloc Concentric locking use the similar size SC or MSC with setscrew locking as shown.

For additional assistance contact Application Engineering at (800) 626-2093.



Table 15 - Sealmaster SC and MSC Housing Bore cont.

Standard Duty		Medium Duty				Nominal Outside Diameter	Housing Dimension Recommendations inch/mm					
Bore Diameter		Part No.	Bore Diameter		Part No.		Outside Diameter		Stationary Housing		Revolving Housing	
inch	mm		inch	mm			inch	mm	Diameters		Diameters	
							Max	Min	Max	Min	Max	Min
2	-	SC-32	1 15/16	-	MSC-31	4 15/16 125.41	4.9385 125.438	4.9365 125.387	4.9405 125.489	4.9385 125.438	4.9375 125.413	4.9355 125.362
2 1/8	-	SC-34	2	-	MSC-32							
2 3/16	-	SC-35	-	50	MSC-310							
-	55	SC-211	-	-	-							
-	-	-	-	-	-	5 7/8 149.23	5.8760 149.250	5.8740 149.200	5.8780 149.301	5.8760 149.250	5.8750 149.225	5.8730 149.174
2 1/4	-	SC-36	2 3/16	-	MSC-35							
2 3/8	-	SC-38	2 1/4	-	MSC-36							
2 7/16	-	SC-39	-	55	MSC-311							
-	60	SC-212	-	-	-	6 1/4	6.2510 158.775	6.2490 158.725	6.2530 158.826	6.2510 158.775	6.2500 158.750	6.2480 158.699
2 1/2	-	SC-40	2 7/16	-	MSC-39							
2 11/16	-	SC-43	2 1/2	-	MSC-40							
-	70	SC-214	-	65	MSC-313							
2 7/8	-	SC-46	2 11/16	-	MSC-43	6 5/8 168.28	6.6260 168.300	6.6240 168.250	6.6280 168.351	6.6260 168.300	6.6250 168.275	6.6230 168.224
2 15/16	-	SC-47	2 3/4	-	MSC-44							
-	75	SC-215	-	70	MSC-314							
-	-	-	2 15/16	-	MSC-47							
-	-	-	3	-	MSC-48	7 158.75	7.0010 177.825	6.9990 177.775	7.0030 177.876	7.0010 177.825	7.0000 177.800	6.9980 177.749
-	-	-	-	75	MSC-315							
-	-	-	3 3/16	-	MSC-51							
-	-	-	3 1/4	-	MSC-52							
-	-	-	3 3/8	-	MSC-54	7 7/16 168.28	7.4385 188.938	7.4365 188.887	7.4405 188.989	7.4385 188.938	7.4375 188.913	7.4355 188.862
-	-	-	-	80	MSC-316							
-	-	-	3 7/16	-	MSC-55							
-	-	-	3 1/2	-	MSC-56							
-	-	-	3 15/16	-	MSC-63	9 1/2 188.91	9.5010 241.325	9.4990 241.275	9.5030 241.376	9.5010 241.325	9.5000 241.300	9.4980 241.249
-	-	-	4	-	MSC-64							
-	-	-	-	100	MSC-320							
-	-	-	-	-	-							

This chart displays the recommended housing dimensions for Sealmaster SC and MSC ball bearings at the various bore diameters and nominal Outer Diameter. For Sealmaster SC and MSC with Skwezloc Concentric locking use the similar size SC or MSC with setscrew locking as shown.

For additional assistance contact Application Engineering at (800) 626-2093.

Vibration Analysis

BALL BEARINGS VIBRATION ANALYSIS

The following equations are used to calculate the fundamental frequencies for Sealmaster and Browning Ball Bearings.

1. If the insert number is known, proceed to step 2. For housed units, identify the bearing insert number by looking up the unit in the dimension tables, then proceed to step 2.
2. Find the Sealmaster or Browning insert number in Table 16 below and identify the series.
3. Select the vibration geometry information (O, I, B, F) from Table 16.
4. Use this information to calculate the fundamental bearing frequencies:
 - Outer Ball Pass Frequency (Hz) = O x RPM
 - Inner Ball Pass Frequency (Hz) = I x RPM
 - Ball Spin Frequency (Hz) = B x RPM
 - Fundamental Train Frequency (Hz) = F x RPM

Symbol Description Units

RPM = Revolutions per Minute RPM

O = Outer Race Frequency Factor

I = Inner Race Frequency Factor

B = Ball Spin Frequency Factor

F = Fundamental Train Frequency Factor

Table 16 - Vibration Geometry Information

Series	Standard Duty Bore Diameter		Medium Duty Bore Diameter		Pitch Diameter (inch) dM	Number Of Balls N	Size of Balls (inch) D	Factor For Outer Race O	Factor For Inner Race I	Factor For Ball Spin B	Factor for F.T.F. F
	inch	mm	inch	mm							
*L-10	*1/2 to 5/8	N/A	-	-	1.138	9	1/4	0.0585	0.0915	0.0361	0.0065
2-012	1/2 to 3/4	20mm	-	-	1.345	9	9/32	0.0593	0.0907	0.0381	0.0066
2-015	13/16 to 1	25mm	-	-	1.544	10	9/32	0.0682	0.0985	0.0442	0.0068
2-13	1 1/16 to 1 1/4R or S	30mm	15/16 to 1	25mm	1.812	9	3/8	0.0595	0.0905	0.0385	0.0066
2-17	1 1/4 to 1 7/16	35mm	1 3/16	30mm	2.115	9	7/16	0.0595	0.0905	0.0386	0.0066
2-19	1 1/2 to 1 9/16	40mm	1 7/16	35mm	2.362	9	1/2	0.0591	0.0909	0.0376	0.0066
2-111	1 5/8 to 1 3/4	45mm	1 1/2	40mm	2.596	10	1/2	0.0673	0.0994	0.0417	0.0067
2-115	1 13/16 to 2R	50mm	1 11/16 to 1 3/4	45mm	2.763	10	1/2	0.0683	0.0984	0.0445	0.0068
2-23	2 to 2 3/16	55mm	1 15/16	50mm	3.051	10	9/16	0.0680	0.0987	0.0437	0.0068
2-27	2 1/4 to 2 7/16	60mm	2 3/16	55mm	3.356	10	5/8	0.0678	0.0989	0.0432	0.0068
2-211	2 1/2 to 2 11/16	70mm	2 7/16 to 2 1/2	65mm	3.846	10	11/16	0.0684	0.0982	0.0451	0.0068
2-215	2 7/8 to 2 15/16	75mm	2 11/16	70mm	4.045	11	11/16	0.0761	0.1072	0.0476	0.0069
2-33	3 to 3 3/16	80mm	2 15/16 to 3	75mm	4.362	11	3/4	0.0759	0.1074	0.0470	0.0069
2-37	3 1/4 to 3 7/16	-	3 3/16	80mm	4.627	11	25/32	0.0762	0.1071	0.0479	0.0069
2-38	3 1/2	90mm	3 7/16	-	4.922	10	7/8	0.0685	0.0981	0.0454	0.0069
2-43	3 15/16 to 4	-	3 15/16 to 4	100mm	5.808	10	1 1/16	0.0681	0.0986	0.0440	0.0068
3-47	5	-	4 7/16 to 4 15/16	-	7.087	10	1 1/4	0.0686	0.0980	0.0458	0.0069

For specific bearing insert, refer to load rating page G-227 to G-229 to determine series

*L-10 series only applies to Browning units for the Bore Diameters shown. For VER-208 and 210 units use the 2-012 series values



Mounted Ball Bearing Engineering see page G-220.

