

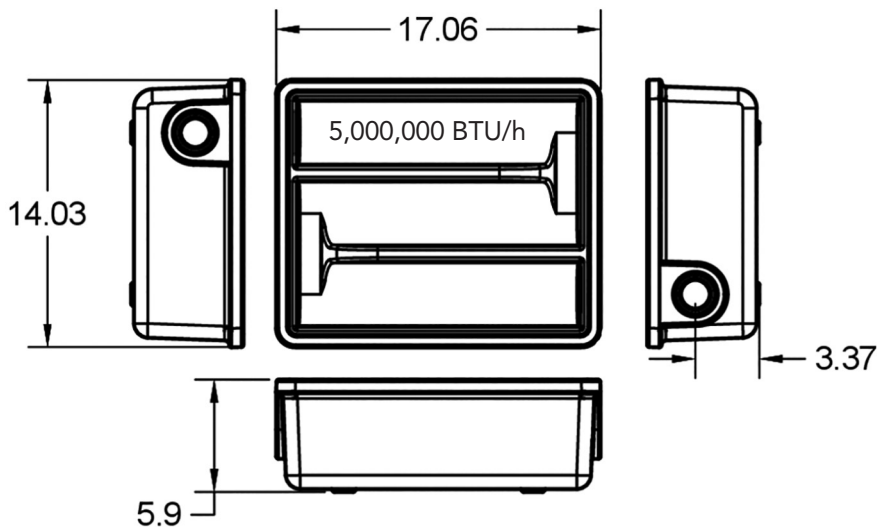

Neutra-Safe® Condensate Neutralizer

Tray Style Model CN5TR

Installation, Operation and Maintenance Manual



⚠ WARNING ⚠

- Neutra-Safe® condensate neutralizers should only be installed by a qualified professional.
- Read all instructions before installing. Perform steps in the order given. Failure to comply could result in substantial property damage, severe personal injury, or death.
- Do not allow flue gases to vent through condensate neutralizer. All condensate drain lines must have a gas trap before entering the neutralization unit. Failure to comply could result in substantial property damage, severe personal injury or death.
- Neutra-Safe neutralizers should only be connected to a condensate outlet that is installed per the appliance manufacturer's instructions. Failure to comply could result in substantial property damage, severe personal injury, or death.

IMPORTANT

- All piping should be in accordance with relevant building and mechanical codes, as well as any local, state or federal regulations.
- Do not connect more than one appliance to each neutralizer.
- Neutralizer should be installed below all traps and condensate outlets.
- Neutra-Safe CN5TR condensate neutralizer should always be mounted on a level surface. It is also recommended that the installer maintain a pitch of ¼" per foot between the condensate neutralizer outlet and the pump or drain.
- Do not use pipe dope on threaded fittings—use only Teflon tape.
- Neutra-Safe condensate neutralizers may **NOT** be installed in the vertical position.
- It is recommended that the neutralizer be installed before the condensate pump.
- All condensate traps should be primed before commencing operation of the appliance.
- Neutra-Safe condensate neutralizer media should be replaced at least once a year or when pH falls below local regulations.

MOUNTING OPTIONS

- It is recommended that Neutra-Safe condensate neutralizers be installed as close as possible to the outlet of the gas trap.
- Always place neutralizer on a level surface.
- Neutra-Safe® condensate neutralizers may be installed on or above the floor so long as a pitch of ¼" per foot is maintained between the neutralizer and the drain or pump.

INSTALLATION

1. Neutra-Safe CN5TR neutralizers have 1" female NPT connections.
2. Unit easily slides out of end of box and is ready to install. Remove plastic bag from cover.
3. If using PVC pipe, apply Teflon tape to the threads of provided PVC socket adaptors and attach to neutralizer.
Do not over tighten.
4. Identify suitable location for condensate neutralizer unit.
5. Be sure media sacks do not block inlet and outlet.
6. Prime and glue PVC pipe to fittings.
7. Route PVC pipe or tubing to drain or pump, maintaining a pitch of 1/4" per foot.
8. Model CN5TR is bidirectional. An atmospheric vent may be needed between appliance and neutralizer.
9. Fill condensate trap with water until flow is established through neutralizer.
10. Observe neutralizer during boiler operation to ensure unrestricted condensate flow.

MAINTENANCE

General

1. All service items should be undertaken by a qualified professional.
2. Visually inspect unit for signs of leaking or damage.
3. Neutralizer media should be replaced at least once a year or when pH falls below local regulations. Neutralizer efficiency can only be determined by measuring pH level of condensate outflow.
4. The CN5TR refill kit is 5TRRCK-S.

Maintenance Steps

1. Lift off cover.
2. Remove 3 used media sacks.
3. Install 3 new media sacks making sure sacks are not blocking inlet/outlet.
4. Prime neutralizer and replace cover.