



# **MAC-120HE-01-32**

## **High Efficiency Air-Cooled Chiller**

10 Ton / 120,000 BTUH Air-Cooled Chiller

**208/230-1-50/60**

# HVAC Guide Specifications

Air-Cooled Liquid Chiller Nominal Size:

**10 Tons**

MultiAqua Model Number:

**MAC-120HE-01-32**

## Part 1-General

### 1.01 System Description

MultiAqua air-cooled liquid chillers are designed using scroll compressors and high volume condenser fans.

### 1.02 Quality Assurance

- A. Certified in accordance with U.L. Standard UL60335-2-40.
- B. Third Party Certified EER Ratings are at ANSI/AHRI Standard 550/590 with Addendum 3-2011 Conditions, unit running at 95°F ambient, 45 °F leaving water temperature with sub-cooling 6.5°F, superheat 11.9°F and with (2) PSC condenser motors.
- C. Manufactured in a facility registered to ISO 9002, Manufacturing Quality Standard, ETL certified.
- D. Damage resistant packaging.

### 1.03 Delivery, Storage and Handling

- A. Packaged and readied for shipment from distribution center.
- B. Controls shall be capable of withstanding 150°F storage temperatures in the control compartment.
- C. Stored and handled per manufacturer's recommendations.

## Part 2-Product

### 2.01 Equipment

#### A. General:

- 1. Unit shall be a factory assembled and tested air-cooled liquid chiller.
- 2. Shall be assembled on heavy gauge steel mounting/lifting rails.
- 3. Contained within the unit cabinet shall be all factory wiring, piping, controls, refrigerant charge (R32), POE oil and special accessories required prior to start up.
- 4. Brass body strainer with 20 mesh screen and blow down shall be supplied in cabinet as a field installable accessory.
- 5. Amtrol 1500/1 expansion tank with air purge shall be supplied in cabinet as a field installed accessory. (See Page 7)

#### B. Unit Cabinet:

- 1. Composed of heavy gauge galvanized steel casing with a baked polyester powder coating.
- 2. Capable of withstanding 500-hour salt spray test in accordance with the ASTM (U.S.A.) standard.

#### C. Condenser Fans:

- 1. Four blade glass reinforced polypropylene (PPG) petals mounted on a cast aluminum hub construction and shall be dynamically balanced and corrosion resistant.
- 2. Discharge air is vertical.
- 3. Motors and blades shall be protected by coated steel wire safety guards.

#### D. Fan Motors:

- 1. Standard condenser fan motors shall be single phase, single speed, direct drive PSC type motors.
- 2. Standard condenser fan motors shall be totally enclosed, use Class B insulation and permanently lubricated ball bearings and/or sleeve bearings.
- 3. Standard condenser fan motors shall be internally overload protected with automatic reset.

**E. Compressors:**

1. Unit shall contain two fully hermetic scroll compressors.
2. Direct-drive, 3500 rpm (50/60Hz).
3. Compressor motor shall be suction gas cooled.
4. Internal motor protection.
5. Externally protected by low and high pressure cutout devices.
6. Individual vibration isolators.

**F. Pump:**

1. Unit shall not be capable of incorporating a field installed chilled liquid solution pump. (Space restricted)
2. Unit shall have chilled liquid solution piping to the exterior of the cabinet.

**G. Evaporator:**

1. Evaporator shall have two independent refrigerant circuits and single liquid solution circuit.
2. Rated for a refrigerant side working pressure of 450 psig and a maximum water side working pressure of 150 psig.
3. Single pass, ANSI type 316 stainless steel, brazed plate construction with copper/nickel brazing material.
4. Externally insulated with closed cell, elastomeric foam. (ASTM518)

**H. Condenser:**

1. Condenser coil shall be air-cooled with integral sub-cooler.
2. Independent condenser coil for each refrigerant circuit.
3. Constructed of rifled copper tubing mechanically bonded to aluminum fins.
4. Cleaned and dehydrated.
5. Factory leak tested to 450 psig.

**I. Refrigerant Circuits:**

1. Each circuit shall contain a sight glass, liquid line strainer, thermal expansion valve, and a refrigerant charge of R32 and POE compressor oil.

**Part 3-Controls and Safeties****3.01 Controls**

- A. Chiller shall be completely factory wired and tested.
- B. Temperature control shall be based on leaving chilled liquid solution temperature.
  1. Temperature accuracy shall be + - 1°F
- C. Controls shall be capable of staging the two compressors.
- D. Controls shall include the following components:
  1. 24vac transformer to serve all controllers relays and control components.
  2. Microprocessor based liquid solution temperature controller.
  3. Leaving water temperature thermistor.
  4. Pump bypass timer.
  5. Compressor recycle timer.
  6. Optional fan cycling control for low ambient operation.
  7. Chilled liquid solution flow switch.

### 3.02 Safeties

- A. Unit shall be equipped with all necessary components in conjunction with the control system to provide the following protection:
1. Low refrigerant pressure.
  2. High refrigerant pressure.
  3. Low chilled liquid solution flow.
  4. Internal motor thermal protection.
  5. Anti-short cycling.

### Part 4-Operating Characteristics

#### 4.01 Temperatures

- A. Unit shall be capable of starting and running at outdoor temperatures from 55°F to 120°F.
- B. Optional Low Ambient Kit shall allow starting and running at outdoor temperatures from 54 °F to 0°F. A field supplied and field installed crank case heater must be used when operating at these temperatures.
- C. Unit shall be capable of initial starting up with a maximum 80°F entering fluid temperature and ambient not above 95° F.
- D. Maximum sustained entering fluid solution temperature to the evaporator shall not exceed 70°F.
- E. **Minimum 10% glycol solution is required in all applications. For outdoor temperatures below 32°F, reference the propylene glycol manufacture's data table of field installed polypropylene glycol solution.**

#### 4.02 Electrical Requirements

- A. Primary electrical power supply shall enter the unit at a single location. Single phase units require phase matched dual line voltage supply. Three phase units require only single line voltage supply.
- B. Electrical power supply shall be rated to withstand 90°C operating ambient temperature.
- C. Units shall be available in single or 3-phase power at the voltages shown in the equipment electrical data.

### Part 5- Definitions

#### 5.01 Abbreviations

- A. DB = Dry Bulb Temperature
- B. EWT = Entering Water Temperature
- C. LWT = Leaving Water Temperature
- D. EAT = Entering Air Temperature
- E. EAT/DB = Entering Air Temperature Dry Bulb
- F. EAT/WB = Entering Air Wet Bulb
- G. GPM = US Gallons Per Minute
- H. MBH = BTU X 1000
- I. SC = Sensible Cooling
- J. TC = Total Cooling = Sensible + Latent
- K. WB = Wet Bulb Temperature
- L. WPD = Water Pressure Drop in feet of head
- M. dB = Decibel Level

#### 5.02 Measurements

- A. All measurements with regard to length, width, and height shall be in inches.
- B. All measurements with regard to pipe sizes shall be in outside diameter (OD) unless otherwise noted.

# MAC-120HE-01-32

## Physical

Model Number	Condenser				Chiller				Weight (lbs.)	
	Height (in)	Length (in)	Copper Tubing Diameter (in)	Coil Rows	Height (in)	Length (in)	Width (in)	Refrigerant R32 (2 Circuits)	Net	Shipping
MAC-120HE-01-32	44	48	3/8	2	57	66	36	11.5 LBS EACH	850	1100

## Electrical Data

Model Number	Volts/ Phase/ Hertz	Compressor (Qty 2)		Condenser Fan Motor (Qty 2)		SCCR	Fuse or HACR Circuit Breaker	
		(RLA)	(LRA)	(RLA)	(RPM)		Minimum Amps(MCA)	Maximum Amps(MOCP)
MAC-120HE-01-32	208/230-1-50/60	30 x 2	174.1 x 2	2.5 x 2	1130	10kA	42.5 x 2 "See note 1"	73 x 2 "See note 1"

**Note:**

- The MAC-120HE-01-32 has two independent line voltage terminations.

Compressor	Copeland Scroll
Refrigerant	R32
Heat Exchanger	Brazed Plate
Max. Flow Rate	28.8 gpm
Min. Flow Rate	18 gpm
Supply Water Temp	44°
Return Water Temp	54°
Minimum System Solution Content	50 Gallons
Expansion Tank Size	3% of Total System
Water Connections	1 3/8" OD Supply & Return
Internal Pressure Drop	18 ft. of head

Multiaqua chillers are designed to operate exclusively with R32 refrigerant in a self-contained, pre-charged refrigerant system. Do not access the closed refrigerant circuit for any reason other than after-sale, after installation component replacement. Routine maintenance and service is to be performed by qualified personnel only.

# MAC-120HE-01-32

LWT (F)	ENTERING AIR TEMPERATURE				LWT (F)	ENTERING AIR TEMPERATURE				LWT (F)	ENTERING AIR TEMPERATURE			
	70°F					80°F					95°F			
	BTU's	TONS	EER	COP		BTU's	TONS	EER	COP		BTU's	TONS	EER	COP
35	114745	9.56	16.08	4.57	35	104739	8.73	12.98	3.89	35	92025	7.67	9.60	2.81
40	125293	10.44	17.53	4.88	40	114997	9.58	14.25	4.16	40	102140	8.51	10.65	3.05
42	128790	10.73	18.02	5.05	42	119820	9.99	14.84	4.28	42	108890	9.07	11.36	3.17
44	132840	11.07	18.58	5.14	44	123600	10.30	15.36	4.36	44	112080	9.34	11.71	3.33
45	136252	11.35	19.06	5.18	45	126412	10.53	15.66	4.43	45	113730	9.48	11.86	3.44
48	142577	11.88	19.94	5.34	48	133421	11.12	16.53	4.58	48	119970	10.00	12.51	3.46
50	145582	12.13	20.36	5.43	50	137610	11.47	17.05	4.67	50	123550	10.30	12.88	3.53
55	155457	12.95	21.75	5.66	55	149462	12.46	18.52	4.94	55	136750	11.40	14.26	3.81
60	161958	13.50	22.65	5.82	60	160051	13.34	19.83	5.16	60	148720	12.39	15.51	4.03

LWT (F)	ENTERING AIR TEMPERATURE				LWT (F)	ENTERING AIR TEMPERATURE				LWT (F)	ENTERING AIR TEMPERATURE			
	100°F					105°F					110°F			
	BTU's	TONS	EER	COP		BTU's	TONS	EER	COP		BTU's	TONS	EER	COP
35	87791	7.32	9.33	2.63	35	84788	7.07	8.61	2.42	35	76517	6.38	7.61	2.12
40	97539	8.13	10.03	2.84	40	93913	7.83	9.25	2.61	40	88702	7.39	8.44	2.37
42	100644	8.39	10.25	2.90	42	98363	8.20	9.63	2.72	42	92387	7.70	8.69	2.44
44	104924	8.74	10.61	3.01	44	101564	8.46	9.81	2.77	44	96839	8.07	8.95	2.52
45	108404	9.03	10.80	3.06	45	103066	8.59	9.91	2.80	45	98836	8.24	9.09	2.56
48	115391	9.62	11.35	3.22	48	109585	9.13	10.30	2.92	48	105094	8.76	9.49	2.68
50	118793	9.90	11.54	3.28	50	113106	9.43	10.56	2.99	50	108991	9.08	9.73	2.75
55	130178	10.85	12.31	3.50	55	123591	10.30	11.19	3.18	55	119749	9.98	10.40	2.94
60	141436	11.79	12.97	3.70	60	135011	11.25	11.92	3.39	60	130234	10.85	10.97	3.11

LWT (F)	ENTERING AIR TEMPERATURE				LWT (F)	ENTERING AIR TEMPERATURE				LWT (F)	ENTERING AIR TEMPERATURE			
	115°F					118°F					120°F			
	BTU's	TONS	EER	COP		BTU's	TONS	EER	COP		BTU's	TONS	EER	COP
35	72870	6.07	7.00	1.95	35	114576	9.55	6.16	1.86	35	71088	5.92	6.15	1.86
40	85990	7.17	7.87	2.20	40	100718	8.39	7.16	2.16	40	77859	6.49	6.44	1.95
42	89388	7.45	8.09	2.27	42	96619	8.05	7.42	2.23	42	80691	6.72	6.65	2.01
44	94008	7.83	8.40	2.36	44	92807	7.73	7.65	2.30	44	86293	7.17	7.03	2.12
45	95813	7.98	8.51	2.39	45	95609	7.97	7.78	2.34	45	87718	7.31	7.13	2.15
48	101498	8.46	8.84	2.49	48	100710	8.39	8.08	2.43	48	93617	7.80	7.46	2.24
50	104918	8.74	9.02	2.54	50	103312	8.61	8.24	2.47	50	96115	8.01	7.62	2.29
55	114816	9.57	9.60	2.71	55	112311	9.36	8.73	2.62					
60	124841	10.40	10.17	2.88	60	121743	10.15	9.26	2.77					

# MAC-120HE-01-32

	Entering Air Temperature			
	<b>95°F</b>			
Percent of Load %	<u>100%</u>	<u>75%</u>	<u>50%</u>	<u>25%</u>
LWT (°F)	44°F	44°F	44°F	44°F
Capacity Point Btu/hr.	112080	123620	135600	136920
Capacity Point Tons	9.34	10.30	11.30	11.41
EER	11.71	14.75	18.54	20.47
<b><u>IPLV</u></b>	<b><u>17.11</u></b>			



The factory provided expansion tank and air/gas purge must be field installed outside of the Chiller’s cabinet and outside of any building. This device must be installed at an elevation above the height of the chiller’s brazed plate heat exchanger. This device will automatically vent out micro air bubbles that are trapped in the system.

In the event of a rupture in the refrigerant/ liquid solution brazed plate heat exchanger, the air purge will vent the refrigerant out of the liquid solution lines in order to prevent the refrigerant from entering the conditioned space via the liquid solution piping.

Ensure that the device does not vent near any continuously operating ignition source (for example: open flames, an operating gas appliance or an operating electric heater)

# MAC-120HE-01-32 Product Specifications

<b>Glycol Solution Concentration Data</b>	
Propylene Glycol %	Min. Ambient Temp
10%	26°F
20%	18°F
30%	8°F
40%	-7°F
50%	-29°F

<b><u>Estimated Propylene Glycol Adjustment Factors:</u></b>		
Percent of Propylene Glycol	Capacity adjustment	Pressure Drop adjustment
	Multiply TONS by:	Multiply PD by:
10%	0.995	1.02
15%	0.992	1.04
20%	0.986	1.08
25%	0.972	1.13
30%	0.96	1.21
35%	0.95	1.26
40%	0.928	1.47
50%	0.878	2.79

## **Important**

### **Required Use of 10% Minimum Propylene Glycol**

MultiAqua Inc. requires a minimum concentration of 10% propylene glycol in the chiller system solution. This requirement applies to all chiller product models for protection of the brazed plate heat exchanger (BPHE), regardless of outdoor ambient operating temperature.

The MultiAqua chiller operating at a 44 leaving water temperature (LWT) will have an internal BPHE temperature of 32 F to 38 F. Without the required MINIMUM 10% concentration of propylene glycol, the unit is susceptible to areas of freezing within the BPHE which could result in failure of the BPHE.

With any deviation from full flow through the BPHE, the BPHE would also be susceptible to areas of freezing within the BPHE. This could be caused by, but not limited to, contaminants being caught in the wye strainer, flow switch or pump failure. Each chiller is supplied from the factory with a Wye strainer that is to be installed on the inlet (suction) side of the pump on the MAC- 036HE, 048HE, 060HE, and MAC120HE chillers.

Failure to follow this requirement will void the chiller warranty. Failure to comply may result in BPHE failure due to freezing followed by compressor failure, all of which are not covered by MultiAqua's warranty.

## MAC-120HE-01-32 Altitude Adjustment Factors

Altitude	Tons
1000 ft.	.995
2000 ft.	.990
3000 ft.	.986
4000 ft.	.983
5000 ft.	.980
6000 ft.	.978

### **Important notes about Low Ambient Operation:**

If the outside temperature is expected to fall below freezing (32°F) in the area where the Multiaqua chiller is to be installed; the installer must take the following precautions. **Failure to do so will void the warranty.**

**To not engage in cold ambient mitigation will result in the failure of components such as the heat exchanger, piping, circulating pump, etc... and or property damage.**

- Keep the liquid solution at a minimum of 10% percent Propylene Glycol even in areas where there is no danger of freezing.
- The percentage amount of glycol recommended is dependent on the expected ambient temperatures and the solution makeup recommendation of the glycol manufacturer. For outdoor temperatures below 32°F, reference glycol manufacture's data table of field installed polypropylene glycol solution.
- Ensure the system circulating pump is in a constant energized mode to keep a continuous circulation of liquid solution.

The Multiaqua chiller is a self-contained, air-cooled condenser, coupled with an insulated brazed plate heat exchanger (evaporator). The system utilizes a scroll compressor to circulate refrigerant between the condenser and heat exchanger. The refrigerant is metered into the heat exchanger with a thermal expansion valve. Protecting the system are both high and low pressure switches as well as a pump flow switch.

Liquid solution (water and propylene glycol; minimum 10 % is required at any ambient) is circulated through the heat exchanger by an externally mounted pump. The liquid solution flows through the heat exchanger to the system supply piping and on to the air handlers.

Factory installed low ambient kits are available for operating ambient temperatures down from 54 °F to 0°F. A field supplied and field installed crank case heater must be used continuously when operating at temperatures below 54 °F. Factory installed low ambient kits consist of an ICM 325 (+) Low Pressure switch set to open at 10PSI for chillers with standard condenser motors.

Initial startup in ambient conditions less than 54 °F requires the activation of the field supplied/field installed crank case heater and must be activated for not less than 4 hours prior to energizing of compressor contactor.

## MAC-120HE-01-32 Sound Data

MODEL #	MAC120HE
Fan Speed	dB(A) @ 3 m
H	68

# MAC-120HE-01-32 Wiring Diagram

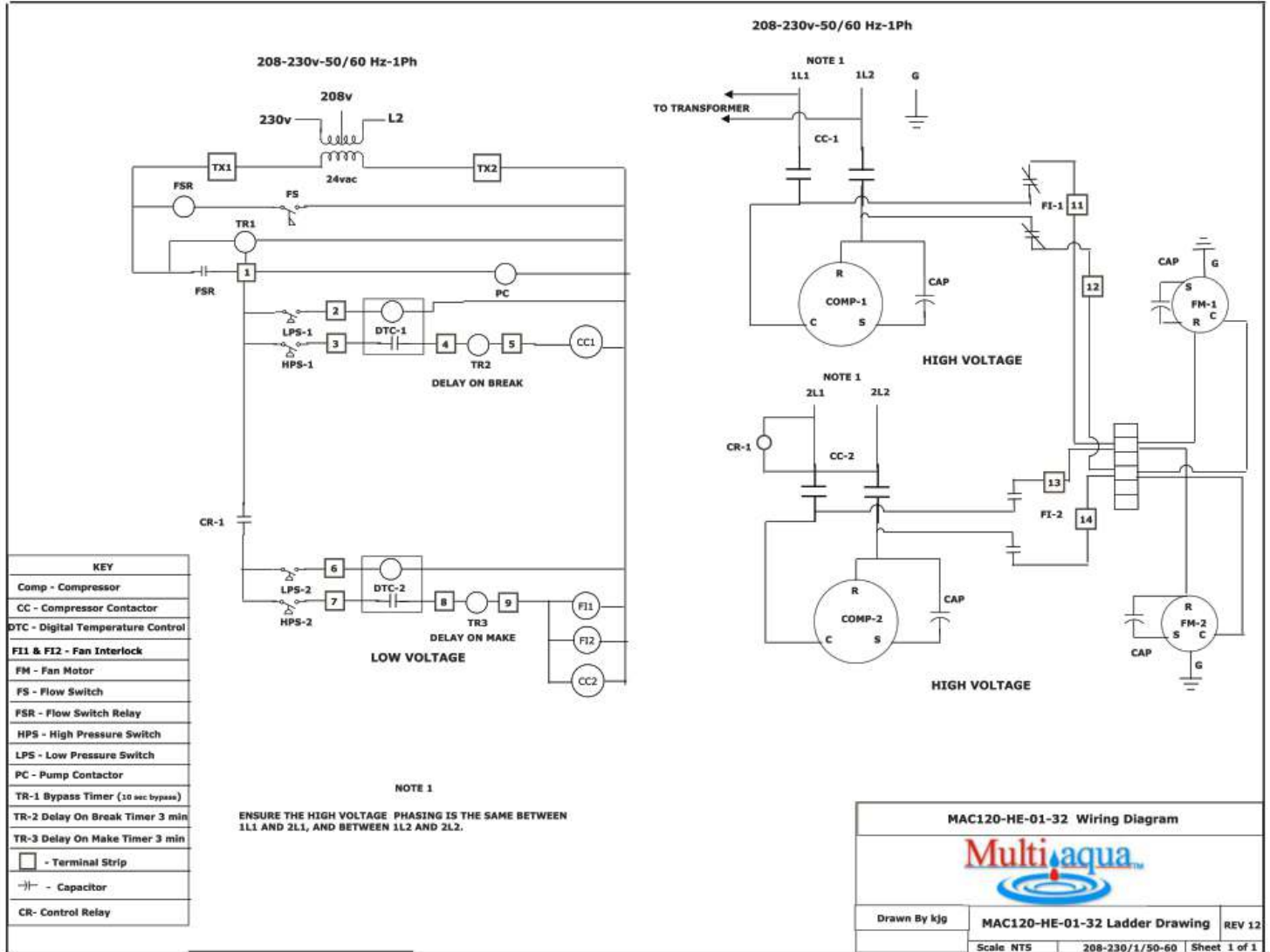

# MAC-120HE-1-32 Dimensional Drawing

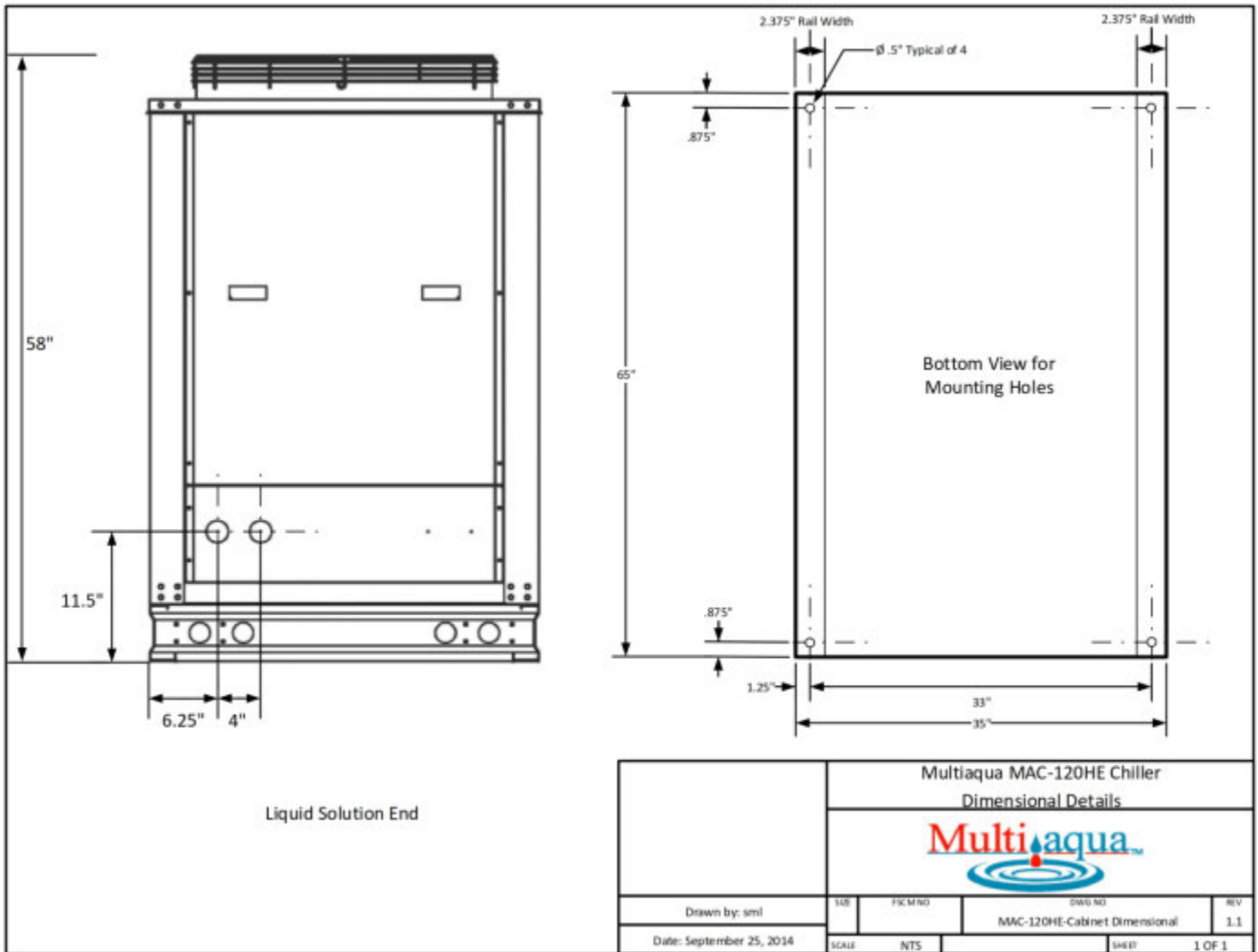

MAC-120HE Minimum Clearances	
Coil Air Inlet Sides	Service Panel Sides
36.00"	36.00"



306 Hagood Street  
Easley, SC 29640  
Ph: 864-850-8990  
Fax: 864-850-8995  
[www.multiaqua.com](http://www.multiaqua.com)

For Technical Assistance:  
1-855-THNK-WTR (1-855-846-5987)