

# MOVINCOOL®

## SERVICE MANUAL

### CLIMATE PRO® D12e

Unit Serial No. Range: 1224\*\*\*\*D12 to Present



Refrigerant  
Safety Group  
A2L

# SERIAL NUMBER LOCATION

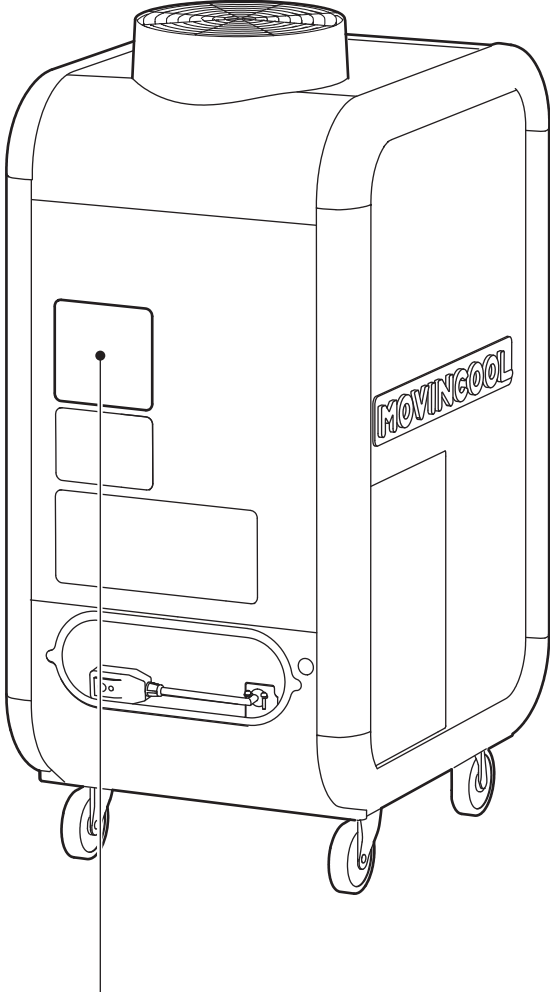

00 00 0000 000  
Month Year Sequential Model  
Number Name

# TABLE OF CONTENTS

<b>SERIAL NUMBER LOCATION</b> .....	<b>2</b>
<b>SAFETY PRECAUTIONS</b> .....	<b>5</b>
<b>CONSTRUCTION</b> .....	<b>9</b>
Dimensions .....	9
Names of Parts .....	10
Internal Structure .....	11
<b>SPECIFICATIONS</b> .....	<b>12</b>
Technical Specifications .....	12
Characteristics in Cool Mode .....	14
Characteristics in Heat Mode .....	15
<b>SERVICE INFORMATION</b> .....	<b>16</b>
Machine Status .....	16
Machine Records .....	17
Flow of Refrigerant System .....	18
<b>OPTIONAL COMMUNICATION MODULE</b> .....	<b>19</b>
Communication Module Hardware Description .....	19
Installation of Communication Module .....	20
Removal of Communication Module .....	23
Battery Removal and Installation .....	24
Reset Communication Module .....	26
<b>TROUBLESHOOTING</b> .....	<b>27</b>
Initial Inspection .....	27
Self-Diagnostic Codes .....	28
Troubleshooting Chart .....	30
Inspection Before Disassembly .....	33
<b>DISASSEMBLY</b> .....	<b>34</b>
Structure Parts .....	35

# TABLE OF CONTENTS

Removal of Panels .....	36
Removal of Louver .....	41
Removal of Bumper .....	42
Removal of Electrical Parts .....	44
Removal of Antenna .....	48
Removal of Blower Assembly .....	50
<b>INSPECTION OF PARTS.....</b>	<b>54</b>
Capacitor .....	54
Drain Switch .....	54
Indoor Fan Motor .....	55
Outdoor Fan Motor .....	56
Compressor .....	57
Thermistor .....	58
High Pressure Switch .....	58
Electronic Expansion Valve Control Coil .....	59
4-Way Valve Controller Coil .....	59
<b>REFRIGERATION SYSTEM .....</b>	<b>60</b>
Before Refrigerant Work .....	60
Replacement of Refrigeration Cycle Parts .....	63
Brazing .....	66
Charging the System with R32 Refrigerant .....	68
<b>REASSEMBLY .....</b>	<b>69</b>
Wiring Diagram .....	69
Compressor Mounting .....	70
Caster Maintenance .....	70
<b>DECOMMISSIONING .....</b>	<b>71</b>
<b>DATA PRIVACY DISCLOSURE .....</b>	<b>72</b>

# SAFETY PRECAUTIONS

To reduce the risk of injury or malfunction, read “Safety Precautions” carefully before servicing the unit.

	<p>Refrigerant Safety Group A2L</p>	<p><b>Risk of Fire. Contains Flammable Refrigerant.</b> Be aware that refrigerants may not contain an odor. All safety precautions must be followed.</p>
--	---	--

The seriousness is classified by the following indicators.

<b>WARNING</b>	<p>Indicates a hazardous situation which, if not avoided, could result in death or serious injury.</p>
<b>CAUTION</b>	<p>Indicates a hazardous situation which, if not avoided, could result in minor or moderate injury, damage to the unit or its components and/or property.</p>

- Serious injuries include loss of vision, bodily injuries, burns, electric shock, fractures, or poisoning, which require prolonged medical treatment and will cause permanent injuries.
- Minor or moderate injuries include bodily injuries, burns or electric shock, which do not require prolonged medical treatment.
- Property includes housing, household goods, livestock, or pets.







### Safety symbols and meanings

<b>This must be done.</b>	<b>This must not be done.</b>	<b>Ensure unit is grounded.</b>
---------------------------	-------------------------------	---------------------------------















<b>WARNING</b>
----------------

	<p><b>Disconnect the power supply from the unit before performing any service. Beware that residual voltage may remain in the unit immediately after the power is disconnected, posing a risk of electric shock.</b></p>
	<p><b>Ensure effective grounding at the outlet.</b> Incomplete grounding may result in fire or electric shock.</p>
	<p><b>Use a dedicated single-outlet circuit for the power supply, with a UL-recognized short-circuit and ground-fault protective breaker.</b> Failure to use the correct power supply may cause fire or electric shock.</p>
	<p><b>Electrical work must be performed by qualified electrical personnel.</b> Failure to use qualified electrical personnel for electrical work may cause fire, electric shock, injury, malfunction or water leaks.</p>
	<p><b>Use genuine MovinCool parts for servicing the units.</b> Non-genuine parts may cause fire, electric shock or water leaks.</p>

 **WARNING**

	<b>All damaged electrical components must be replaced rather than repaired.</b> This is essential to mitigate risks such as fire, electric shock, or malfunction.
	<b>Inspect cables for wear, corrosion, pressure, vibration, sharp edges, and environmental effects, including aging and continuous compressor/fan vibration.</b> Failure to do so may result in fire, electric shock, or malfunction.
	<b>Do not install the unit in an environment which contains corrosive gas or vapor.</b> This may deteriorate the insulation and result in electric shock or fire. This may corrode pipes and result in leaks.
	<b>Do not install the unit in an environment which contains excessive amounts of flammable gas, conductive dust or oil.</b> This may cause an explosion or fire.
	<b>Do not install the unit in a place where flammable gas may generate, flow, gather or leak. Do not install the unit in a place where conductive dust or oil is floating.</b> This may cause an explosion or fire.
	<b>Ensure that the warning labels attached to MovinCool units are easily visible.</b>
	<b>Refrigerant service must be performed only by A2L refrigerant certified professionals.</b> Failure to use A2L refrigerant certified professionals for refrigerant services may cause fire, burns, injury or malfunction.
	<b>Do not perform refrigerant service in an environment which contains flammable gas or vapor.</b> This may cause fire, burns, injury or malfunction.
	<b>Avoid refrigerant work near flammable materials including smoking. Work in a well-ventilated area only.</b> Failure to do so may lead to an explosion, fire, or a lack of oxygen.
	<b>Do not to mix different types of refrigerants when charging. Use only the specified refrigerant (R32).</b> Failure to do so may result in fire, an explosion, or malfunction.
	<b>Use tools designed specifically for R32 refrigerant.</b> Mixing different types of refrigerants can cause sludge, which can lead to compressor failure or clogging of the refrigerant system.
	<b>Before replacing any refrigerant system parts, ensure that all refrigerant in the system has been recovered.</b>

 **WARNING**

	<b>Always wear proper eye protection and gloves while handling refrigerant. Be careful not to allow refrigerant come into contact with eye or skin.</b> Failure to do so may lead to loss of vision or burns.
	<b>Provide a fire extinguisher near the workspace.</b>
	<b>Use a R32 refrigerant detector to check for refrigerant leaks before and during work.</b>
	<b>Ensure that electrical components and wiring are not exposed during refrigerant works.</b> There is a risk of fire, electric shock, or malfunction.
	<b>Contains flammable refrigerant. Do not pierce or burn.</b> This may cause an explosion or fire.
	<b>Maintain the temperature of the refrigerant container below 104 °F (40 °C).</b> Failure to do so may lead to an explosion or fire.
	<b>Do not use cleaners that contain chlorine when cleaning pipes of refrigerant system.</b> Chlorine cleaners may damage pipes. There is a risk of fire, electric shock, or malfunction.
	<b>Store the unit in an appropriate location to avoid mechanical damage.</b>
	<b>Store the unit in a well-ventilated area away from continuously operating ignition sources such as open flames, active gas appliances or electric heaters.</b> Neglecting to do so could lead to an explosion or fire.
	<b>Decommissioning shall be done only by A2L refrigerant certified professionals.</b> Refrigerant handling and disposal must be conducted according to Federal, State and Local regulations.
	<b>Brazing must be performed only by A2L refrigerant certified professionals.</b> Failure to do so may lead to fire, burns, injury or malfunction.
	<b>Before brazing, ensure that all refrigerant in the system has been recovered.</b>
	<b>When brazing, always wear eye protection and gloves.</b> Failure to do so may lead to loss of vision or burns.
	<b>Work in a well-ventilated area while brazing.</b> Failure to do so may lead to an explosion, fire or lack of oxygen.

 **CAUTION**



**Be aware of any sharp edges when working on unit.**  
There is a risk of injury.



**Do not use sharp object to press the reset button when resetting communication module.**  
This may damage the control panel.

# CONSTRUCTION

## Dimensions

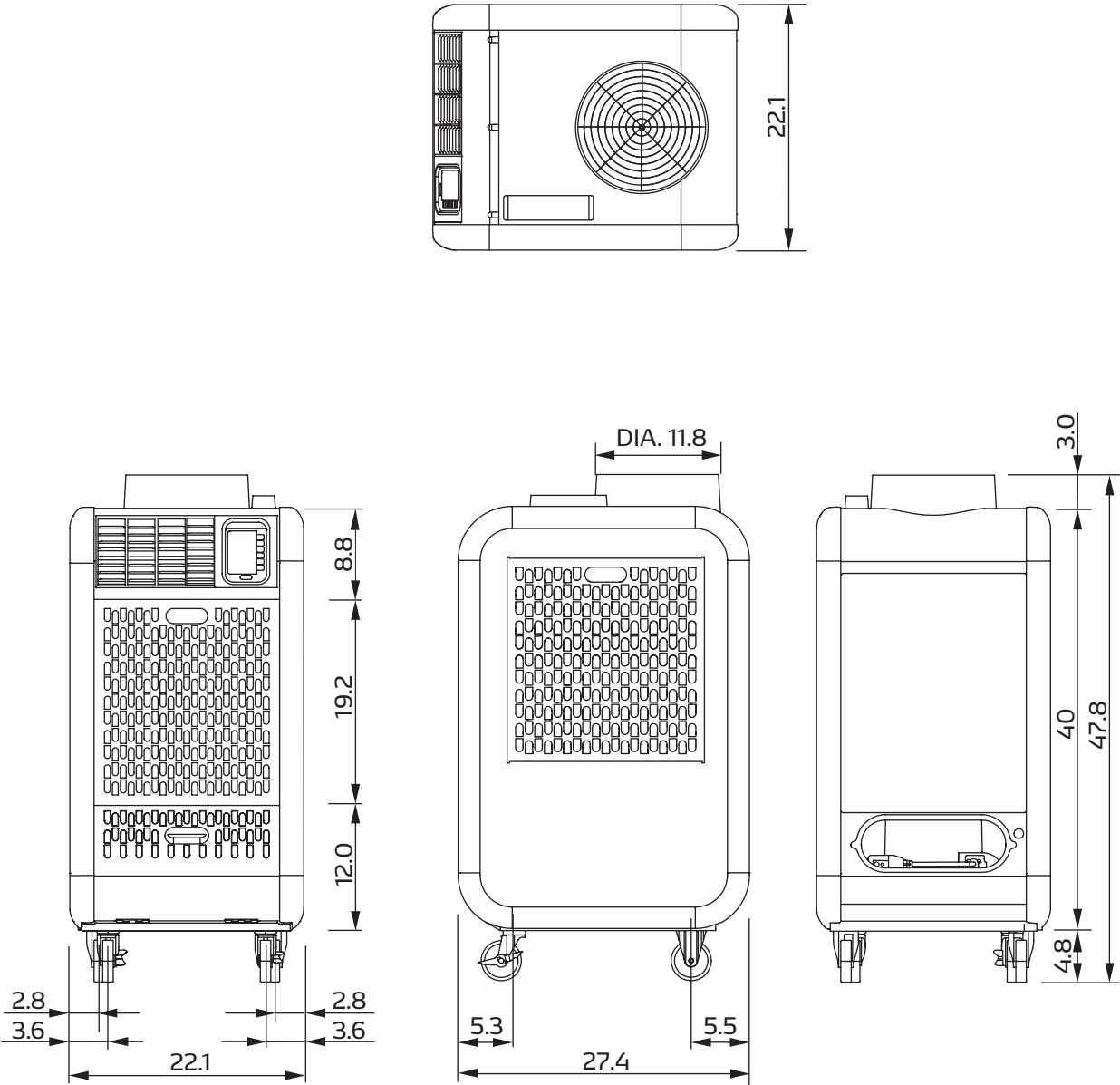

Unit: inch

# Names of Parts

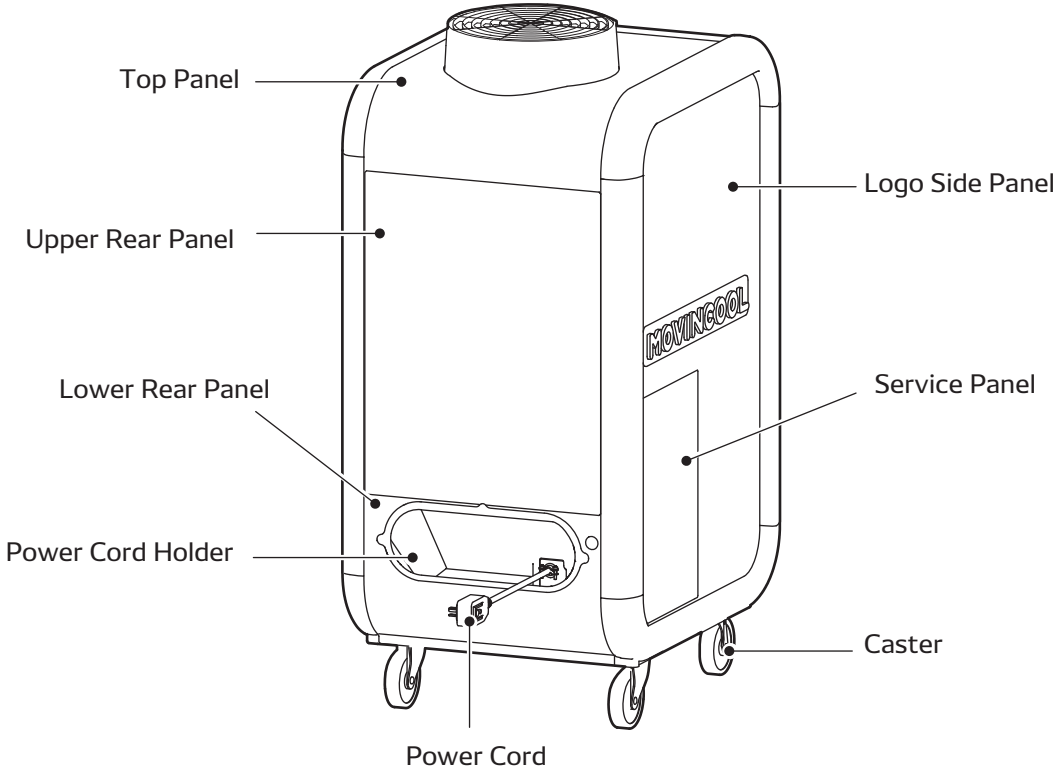
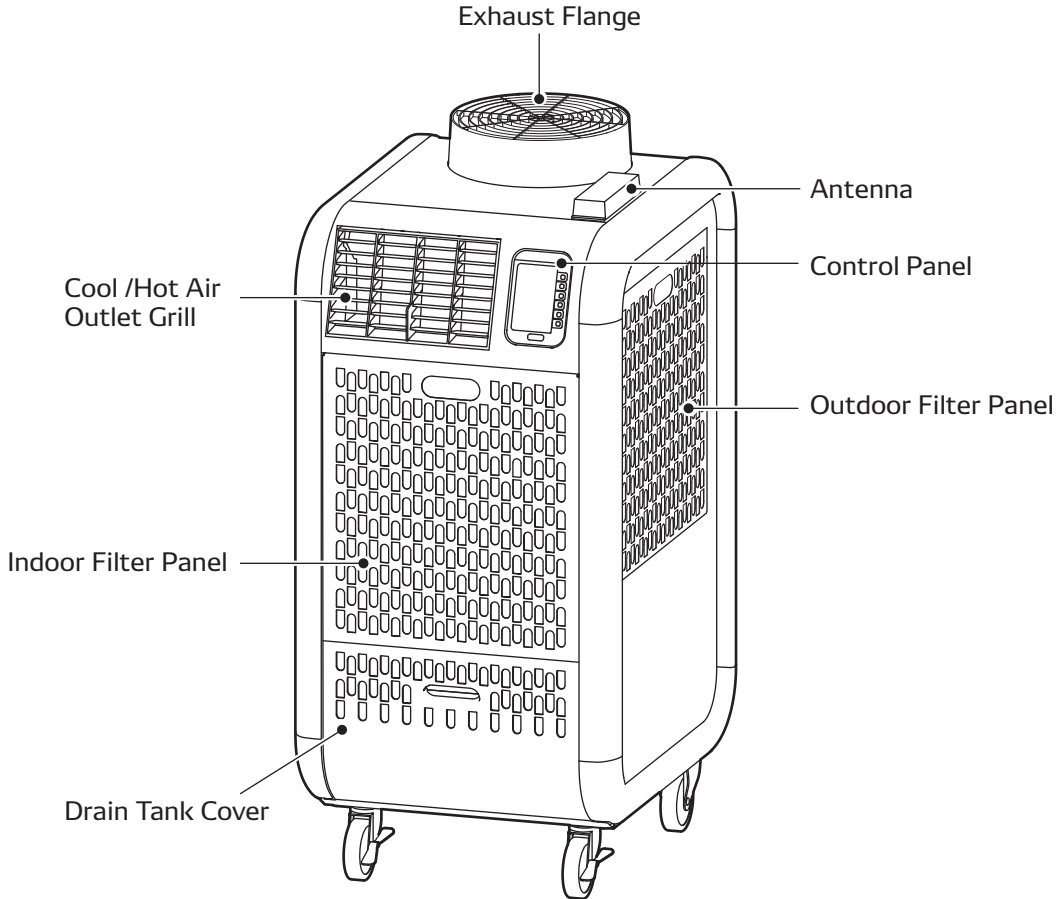

# Internal Structure

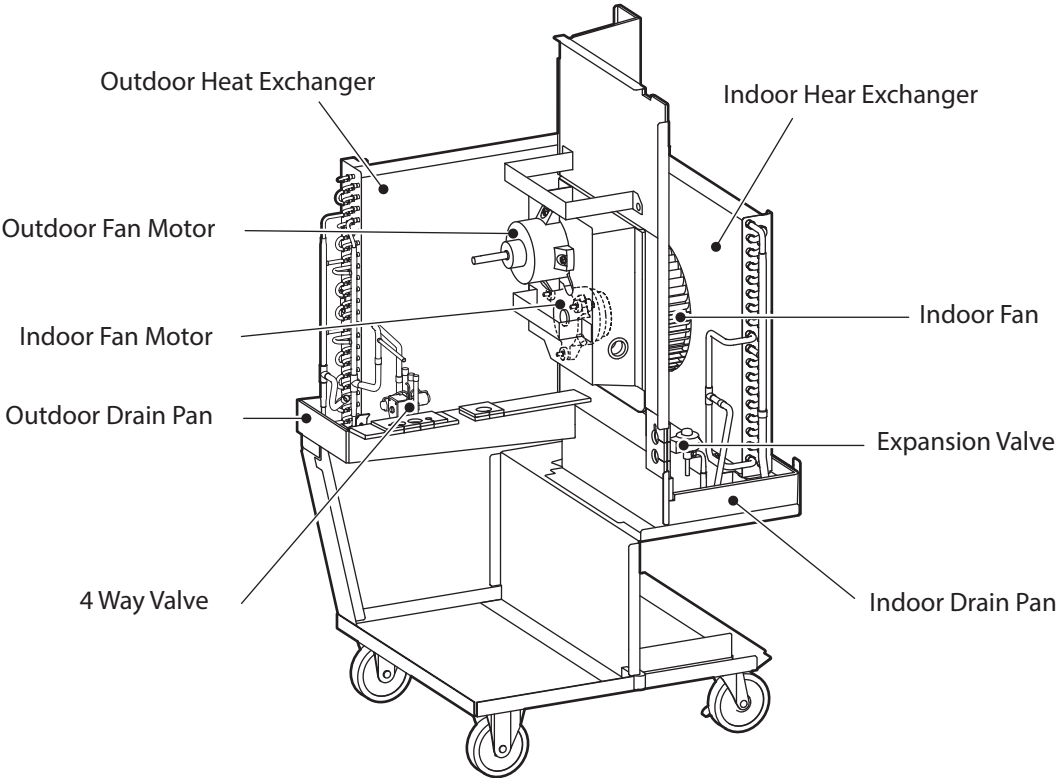
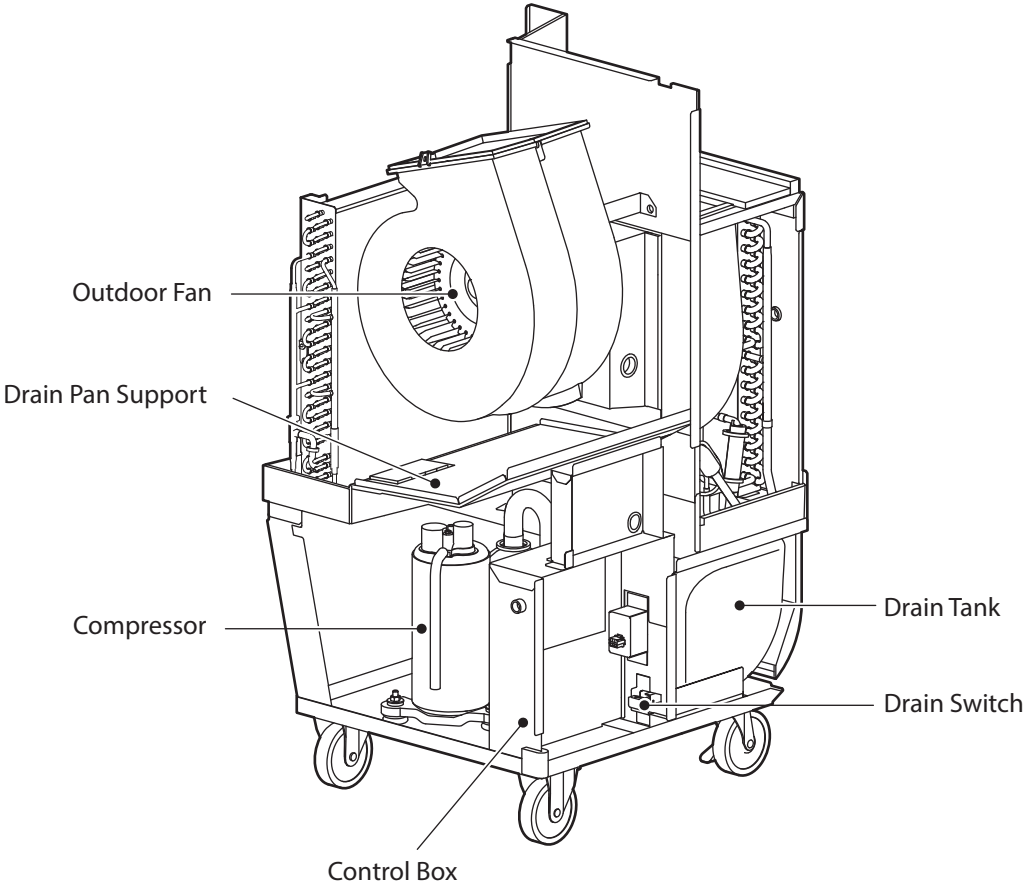

# SPECIFICATIONS

## Technical Specifications

ITEM		SPECIFICATIONS	
Electronic Features	Control	Programmable	
Electronic Characteristics	Power Requirement	115V, 1Phase, 60Hz	
	Starting Current	51 amps	
	Recommended Breaker Size	15 amps	
	Min. - Max. Voltage	104 -127	
Cooling	Capacity *1	Total Capacity 11,450 Btu/h	
	Electronic Characteristics	Total Power Consumption *1	1.2kW
		Current Consumption *1	10.9 amps
		Energy Efficiency Ratio (EER)	9.4
	Fans	Motor Rated Output	0.06 kW
Heating	Capacity *2	Total Capacity 9,900 Btu/h	
	Electronic Characteristics	Total Power Consumption *2	1.1 kW
		Current Consumption *2	9.3 amps
		Energy Efficiency Ratio (EER)	9.5
	Fans	Motor Rated Output	0.12 kW
Indoor Heat Exchanger (Supply)	Fan Type	Centrifugal	
	Max. Air Flow - high/mid/low	420/340/280 CFM	
	Max. External Static Pressure	0.31 IWG	
Outdoor Heat Exchanger (Exhaust)	Fan Type	Centrifugal	
	Max. Air Flow	760 CFM	
	Max. External Static Pressure	0.19 IWG	
Refrigerant Circuit	Compression Type	Hermetic Rotary	
	Motor Rated Output	0.70 kW	
	Indoor Heat Exchanger	Plate Fin	
	Outdoor Heat Exchanger	Wave Fin	
	Refrigerant Control	Electronic Expansion Valve	
	Max. Allowable Pressure - high/low	865/391 PSIG	
Refrigerant	Type	R32	
	Amount	1.17 lb (0.53 kg)	
Power Cord	NEMA Plug Configuration	5-15P	
	Gauge	14 AWG (3-core)	
	Length	10 ft	

# Technical Specifications

ITEM		SPECIFICATIONS		
Condensate Tank Capacity		5 ± 0.5 gal		
Safety Device	Internal Overload Relay for Compressor	320°F ± 9°F (160°C ± 5°C) 54 amps		
	Anti-Freezing Thermostat for Indoor Heat Exchanger	On: 60°F ± 1.8°F (15.6°C ± 1°C) Off: 27°F ± 1.8°F (-3°C ± 1°C)		
	High Pressure Switch	On: 3.0 ± 0.15MPaG Off: 4.0 ± 0.10MPaG		
Signal Connection	Fire Alarm Input	No voltage contact input. Contact resistance: less than 100 ohm		
	Warning Signal Output	2 amps at 30V (DC/AC) max. with resistive load		
Appearance	Paint color	Black		
	Dimensions - W x D x H	22 x 27 x 47 in		
Net weight		186 lb		
Packaging	Dimensions - W x D x H	26 x 31 x 54 in		
	Weight	221 lb		
Operating Condition	Cooling	Min.	65°F (18°C), @ 50% RH	
		Max.	95°F (35°C), @ 60% RH	
	Heating Min. - Max. @ 50% RH	Without Plenum		40°F - 80°F (4.4°C - 27°C)
		With Plenum	Indoor	40°F - 80°F (4.4°C - 27°C)
			Outdoor	24°F - 80°F (-4.4°C - 27°C)
Max. Sound Level *3	With Duct -high/mid/low		62/61/60 dB(A)	
	Without Duct -high/mid/low		62/61/60 dB(A)	
Max. Duct equivalent Length	Supply Duct Hose		30 ft	
	Exhaust Duct Hose		100 ft	
Operating Environment		Indoor		
IP Number		IPX1		

Specifications are subject to change without notice.

\*1: Rating condition: 95°F (35°C) at 60% RH

\*2: Rating condition:

- Indoor: 70°F (21°C) at 50% RH

- Outdoor: 47°F (8°C) at 70% RH (Without Plenum)

\*3: Measured 3 ft (1.0m) away from the front of the unit

# Characteristics in Cool Mode

<Cooling Capacity Curve>

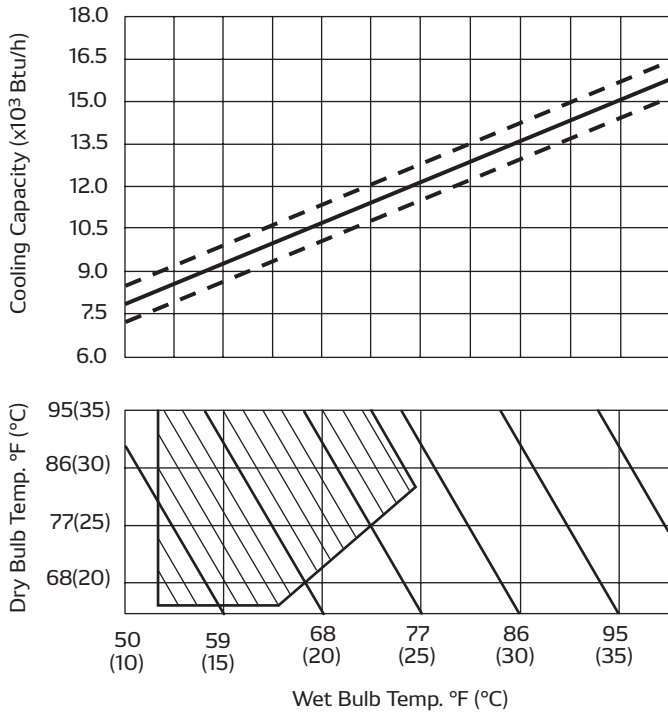

<Cool Air Temperature Difference Curve>

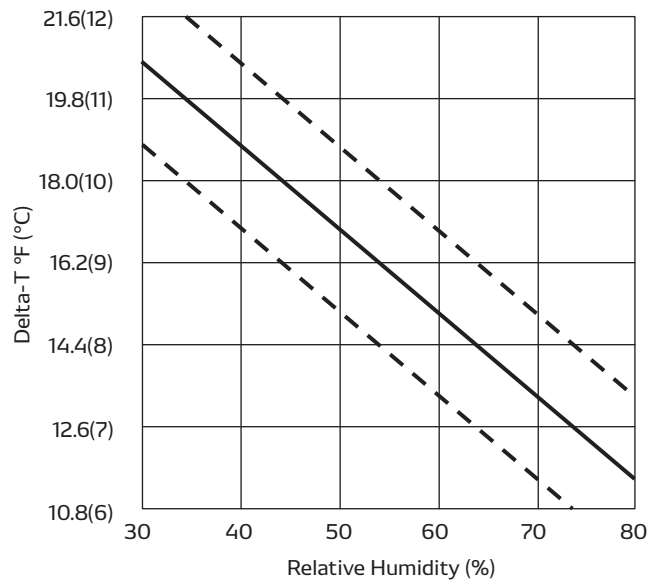

<Power Consumption Curve>

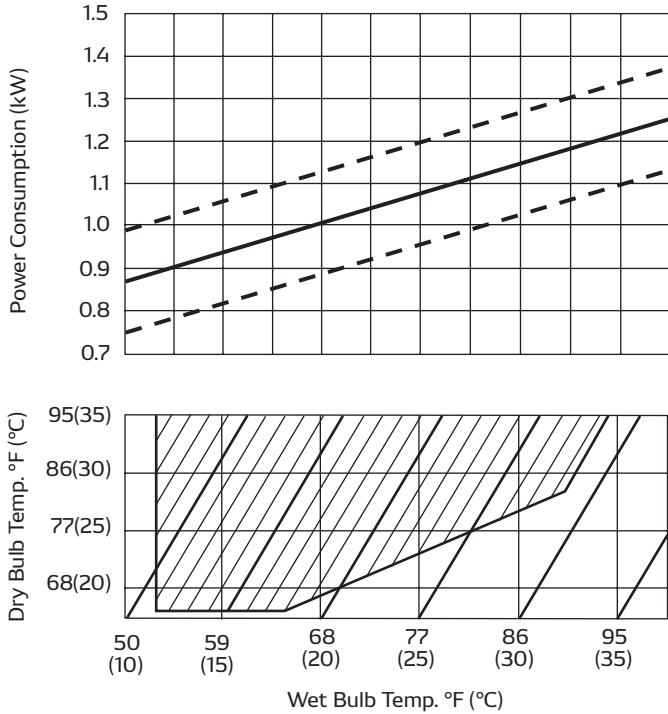

<Current Consumption Curve>

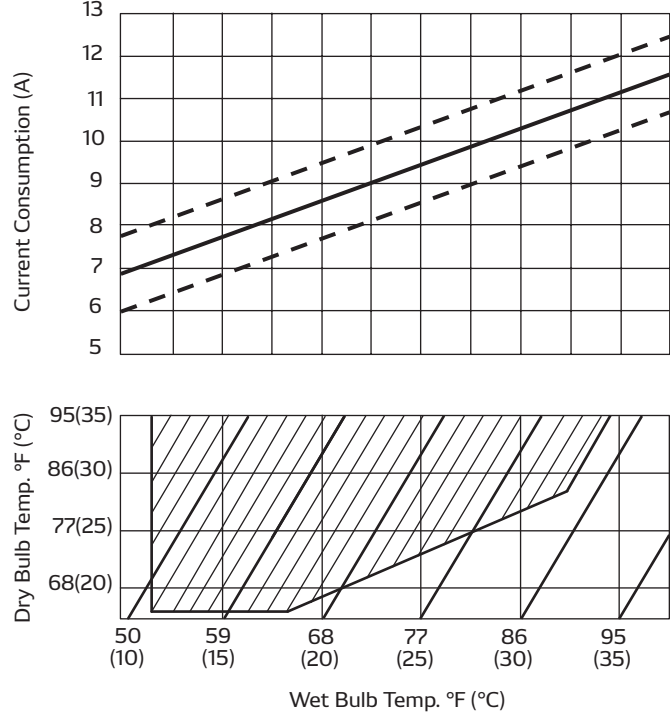

# Characteristics in Heat Mode

<Heating Capacity Curve>

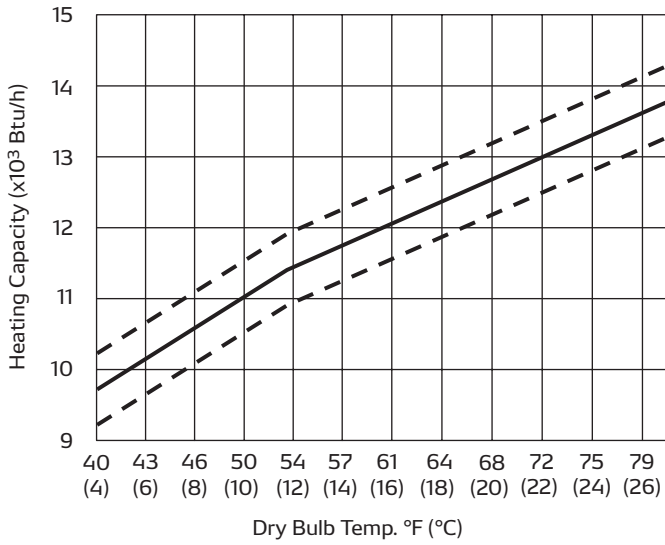

<Hot Air Temperature Difference Curve>

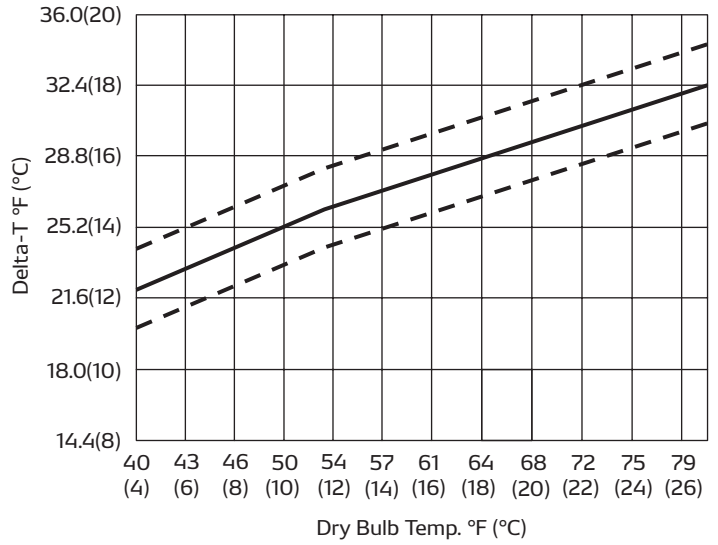

<Power Consumption Curve>

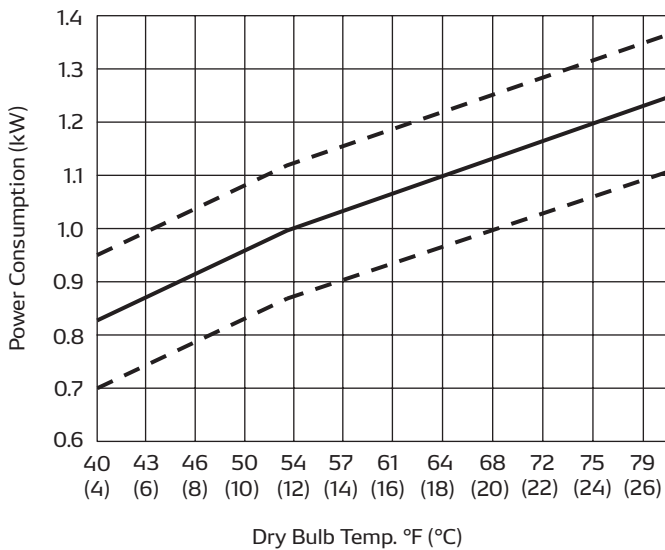

<Current Consumption Curve>

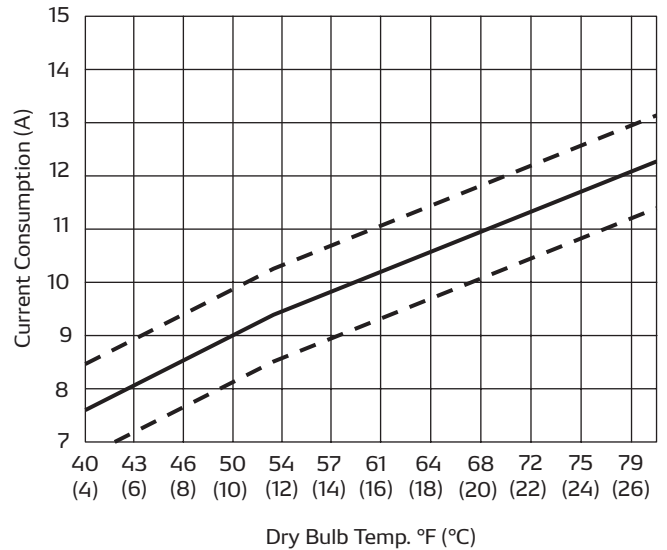

# SERVICE INFORMATION

## Machine Status

The status of functional parts can be displayed while the unit is running.

HOME > MENU > SERVICES > MACHINE INFORMATION > MACHINE STATUS

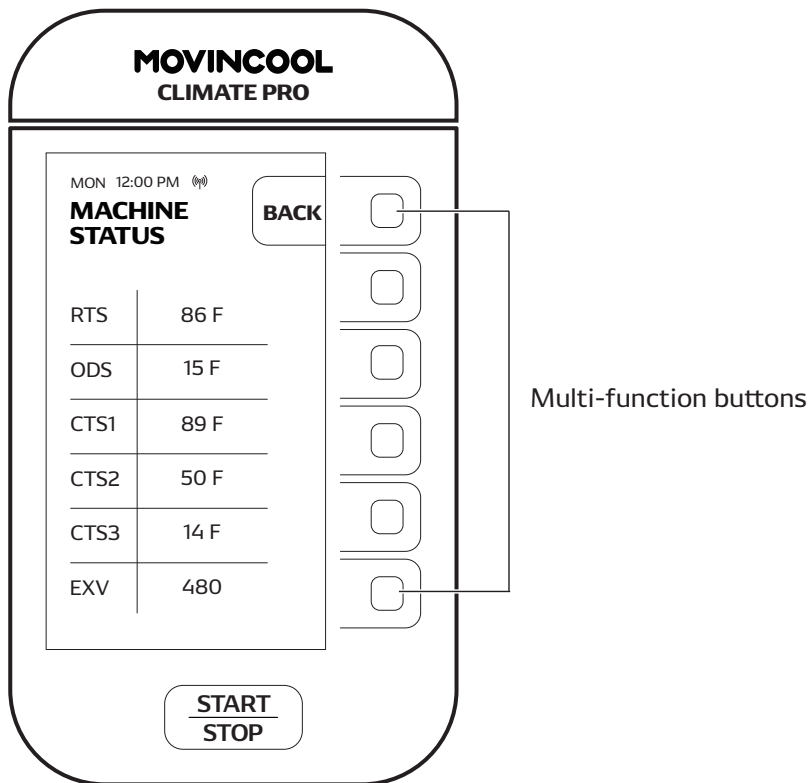

CODE	ITEM	UNIT
RTS	Room thermistor temperature	°F/°C
ODS	Outdoor thermistor temperature	°F/°C
CTS1	Compressor pipe thermistor temperature	°F/°C
CTS2	Evaporator pipe thermistor temperature	°F/°C
CTS3	Condenser pipe thermistor temperature	°F/°C
EXV	Electronic expansion valve opening	-

Note:

- If you need to change temperature scale, go to HOME > MENU > SETTING > TEMP SCALE.

# Machine Records

The history of connection time, compressor operating time, defrosting time, fan operating time, and self-diagnostic codes are displayed while the unit is running.

HOME > MENU > SERVICES > MACHINE INFORMATION > MACHINE RECORDS

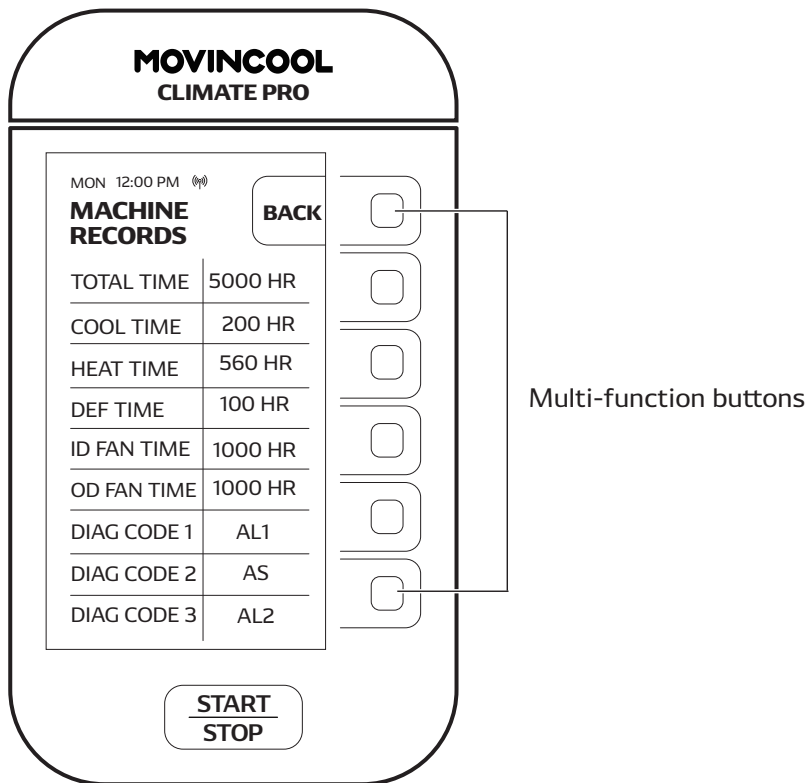

DISPLAY ITEM	DESCRIPTION	UNIT
TOTAL TIME	Total connection time	hour
COOL TIME	Total compressor operating time during cool mode	hour
HEAT TIME	Total compressor operating time during heat mode	hour
DEF TIME	Total defrosting time during heat mode	hour
ID FAN TIME	Total indoor fan operating time	hour
OD FAN TIME	Total outdoor fan operating time	hour
DIAG CODE 1	Self-diagnostic code 1: Latest code	AL1 (example)
DIAG CODE 2	Self-diagnostic code 2: Previous code before the DIAGNOSTIC CODE 1	AS (example)
DIAG CODE 2	Self-diagnostic code 3: Previous code before the DIAGNOSTIC CODE 1 and 2	HP (example)

- Up to 65,500 hours can be stored before being cleared and reset to zero.
- Up to 3 different recorded self-diagnostic codes are displayed.

Note:

- If the item is not applicable for the unit, " --- " is displayed.

# Flow of Refrigerant System

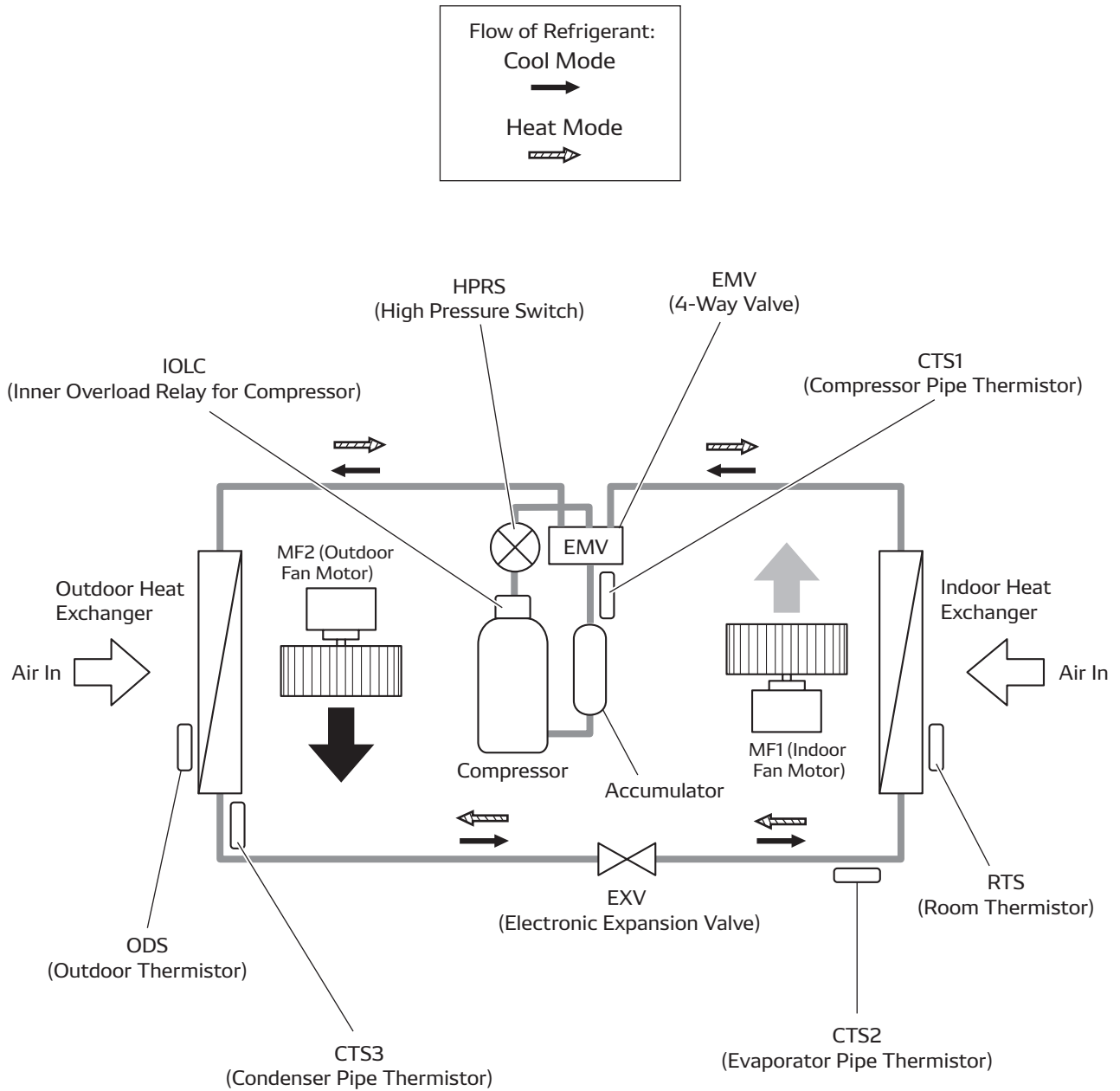

# OPTIONAL COMMUNICATION MODULE

## Communication Module Hardware Description

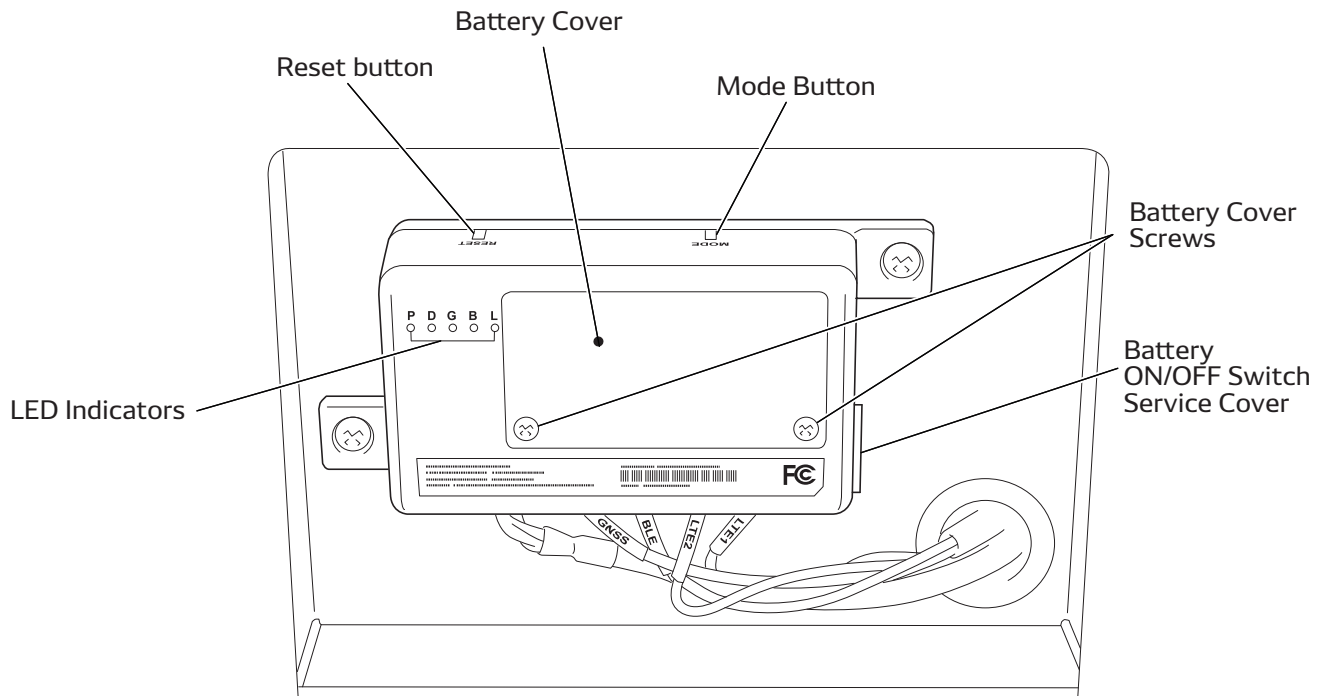

Table of LED Indication

LABEL	NAME	COLOR	LED "ON"	LED "OFF"	LED BLINKING
P	Power LED	Red	Working	Sleeping	Error
D	Device LED	Orange	In Inspection Mode*	NOT in Inspection Mode	Receiving data via DEVICE I/F Port
G	GNSS LED	Blue	GNSS Fixed (Location data is acquired)	GNSS Not Fixed (Location data is NOT acquired)	- (G LED does not blink)
B	BLE LED	Orange	Connected to BLE gateway	Disconnected to BLE gateway	- (B LED does not blink)
L	LTE LED	Orange	Connected to LTE network	Disconnected to LTE network	- (L LED does not blink)

\*Inspection mode is for internal use

# Installation of Communication Module



- **Disconnect power before installation. Beware that some residual voltage may remain in the unit immediately after the power is disconnected. There is a risk of electric shock.**

1. Unplug the unit.
2. Loosen the bottom two (2) screws and remove the other seven (7) M4 x L10 screws. Move the service panel upward and remove it from the logo side panel.

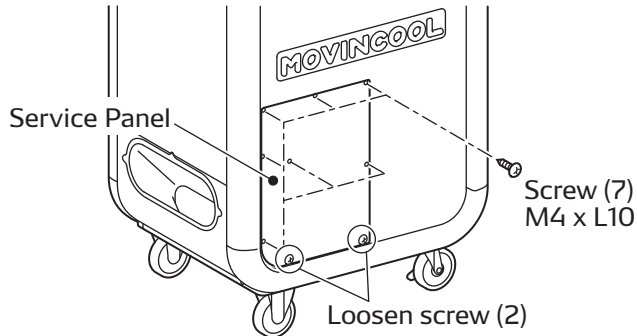

3. Remove the tape and the bubble-wrap from the wire assembly on the control box as shown.

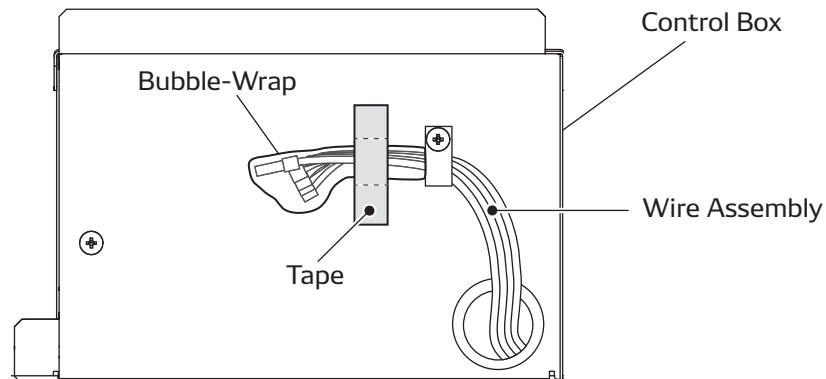

4. Remove the two (2) M4 x L10 screws from the control box. Discard the clip which secured the wire assembly.

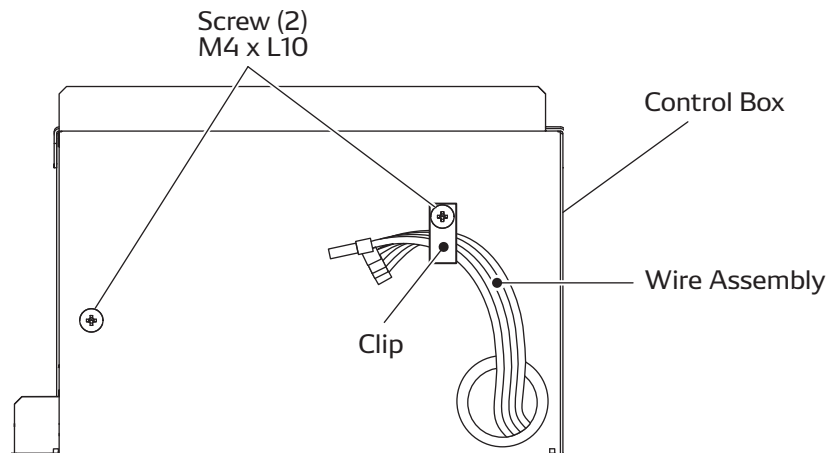

# Installation of Communication Module

5. Connect each connector with its corresponding socket on the communication module as shown. Make sure all connectors are secured by confirming with a click sound and/or pull check.

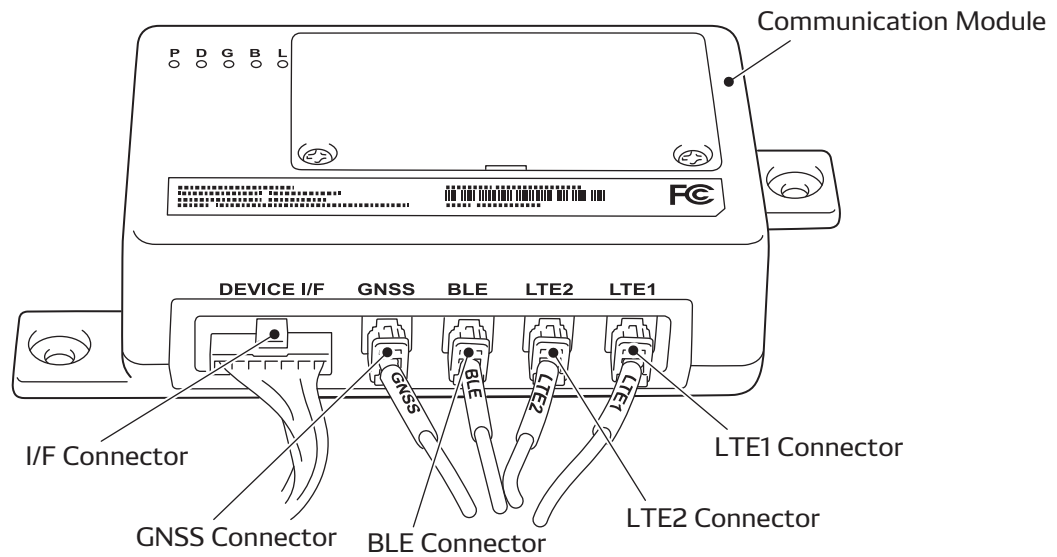

Check and ensure proper connection to the following:

LTE1 wire connects to the connector on the module labeled as LTE1 and LTE2 wire connects to the connector on the module labeled as LTE2 since both are same color (Green connectors).

GNSS wire with brown connector to the connector on the module labeled as GNSS.

BLE wire with blue connector to the connector on the module labeled as BLE.

6. Remove the service cover of the module.

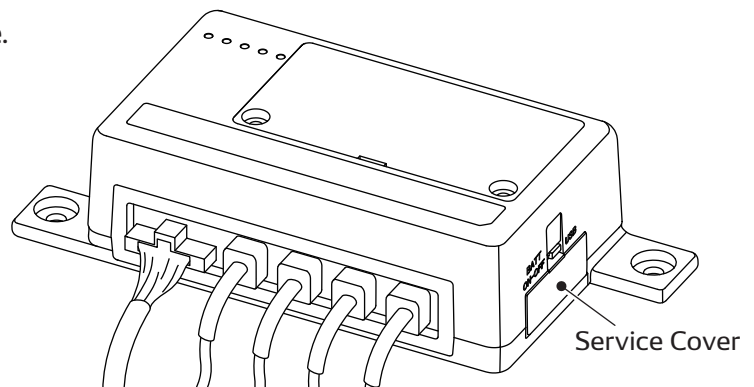

7. Set the battery switch to "ON" position.

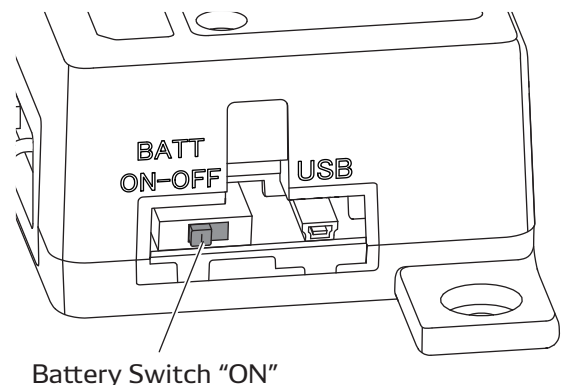

## Installation of Communication Module

8. Install the module with the two (2) M4 x L10 screws, which were removed at step 4.
9. Plug in the unit to ensure the module is working.  
The three (3) LED indicators on the module should show the colors: P: Red G: Blue L: Orange

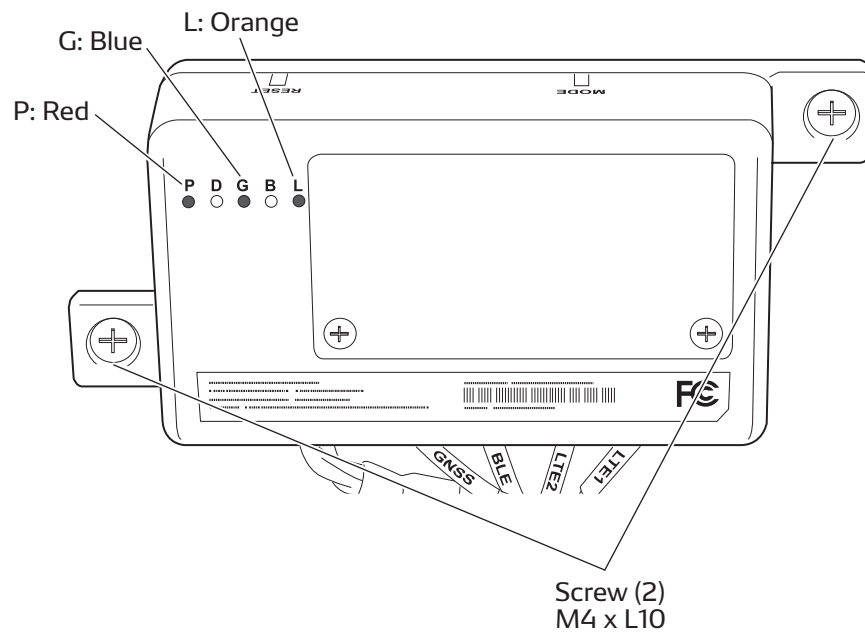

### Note:

- If the LED does not turn on, see Troubleshooting on page 32.

10. Unplug the unit again and install the service panel.

# Removal of Communication Module

1. Loosen the bottom two (2) screws and remove the other seven (7) M4 x L10 screws. Move the service panel upward and remove it from the logo side panel.

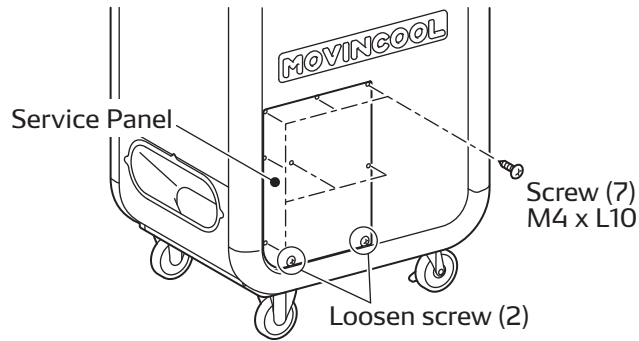

2. Disconnect the five (5) connectors from the communication module.

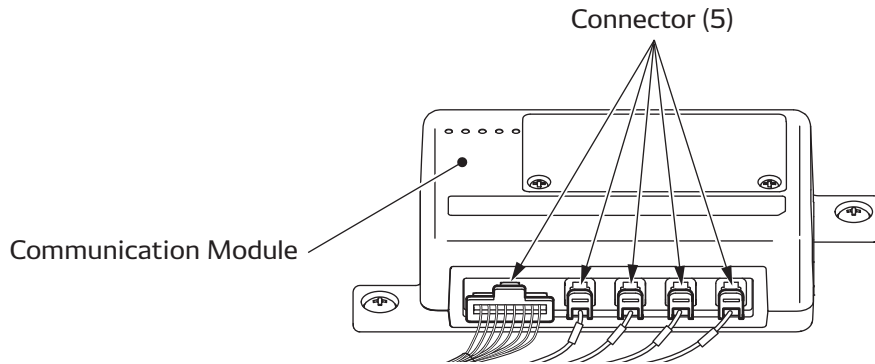

3. Remove the two (2) M4 x L10 screws, and remove the communication module.

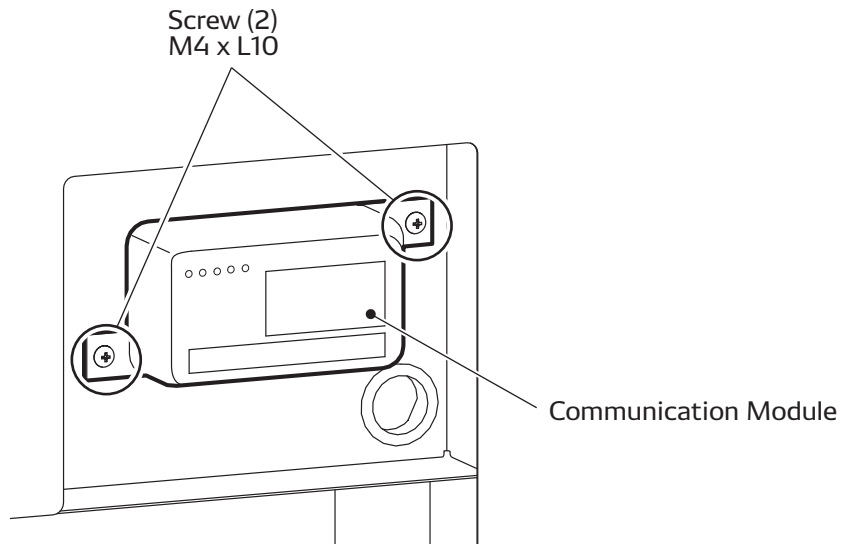

# Battery Removal and Installation

Battery Specification	Model	SC-04002-02
	Nominal Voltage	3.7V
	Nominal Capacity	2500 mAh

Note:

- Before disconnecting the battery, place the battery switch to “OFF” position.  
(See step 6, Set Communication Module to Operate by Internal Battery)

- Remove two screws from battery cover.
- Disconnect battery connector by pressing connector tab and pulling battery connector from the connector socket inside the module.

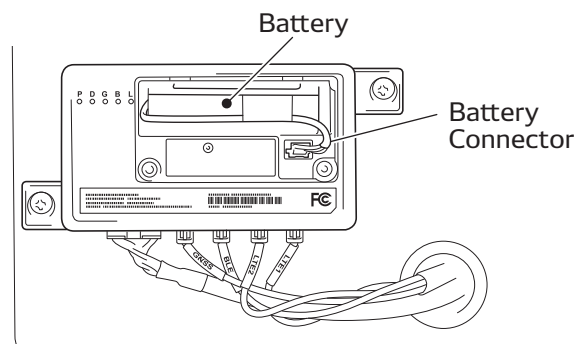

- To install battery, insert battery connector into the connector socket until it clicks to ensure proper connection.

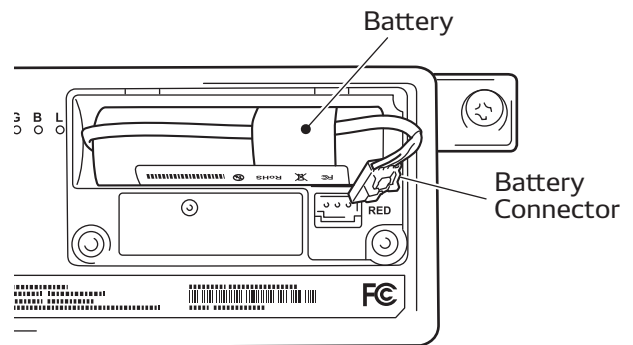

- Place battery in the hollow space and ensure battery wires are in place. Insert the two pins of battery cover into housing then close the cover and secure with the two screws.

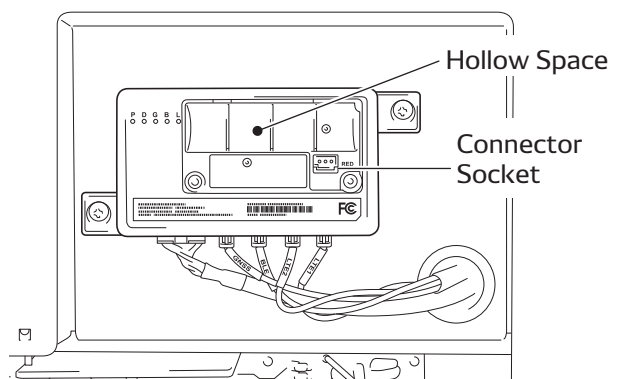

## Battery Removal and Installation

5. I/F Cable (see "Removal of Electrical Parts")
  - a) Follow step in control panel removal then disconnect CN2 from the control board.
  - b) Disconnect I/F connector from communication module.

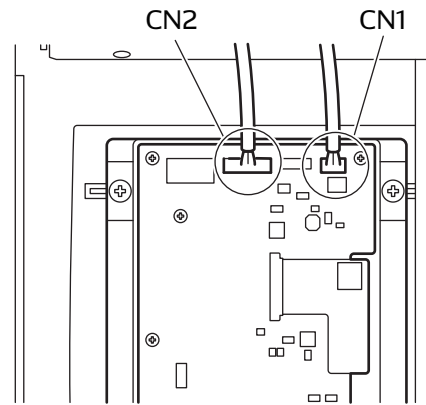

6. Set Communication Module to Operate by Internal Battery

- a) Remove service cover

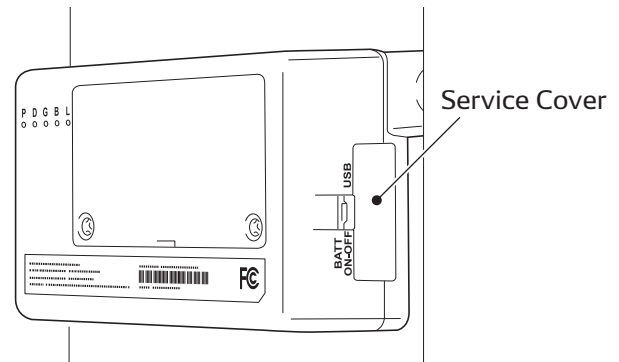

- b) Set the battery switch to "ON" position.

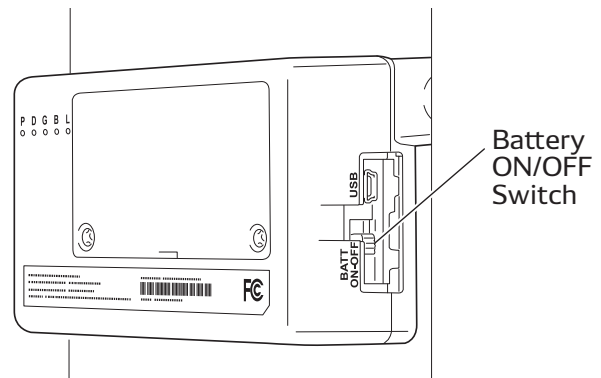

- c) Wait for network to connect, after connection L LED (orange) lights up. LEDs lights up for 3 minutes then go to sleep mode (all LEDs turn off to save battery life)

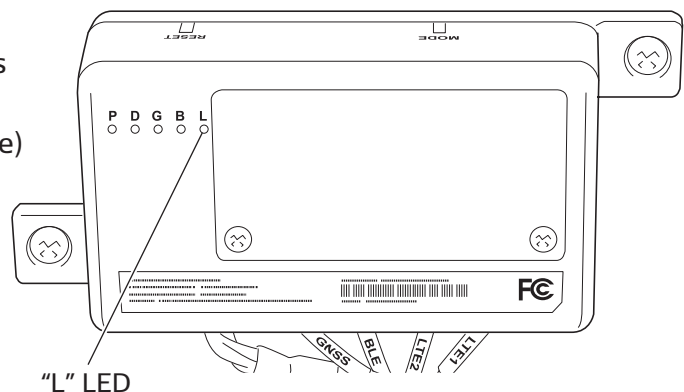

## Reset Communication Module

1. Remove the service panel.
2. Use a nylon or wooden tool to press RESET button of the communication module.

### CAUTION

- Do not use sharp objects to press the reset button as it may damage the control panel.

3. "P" LED blinks once to acknowledge that the RESET have been completed.

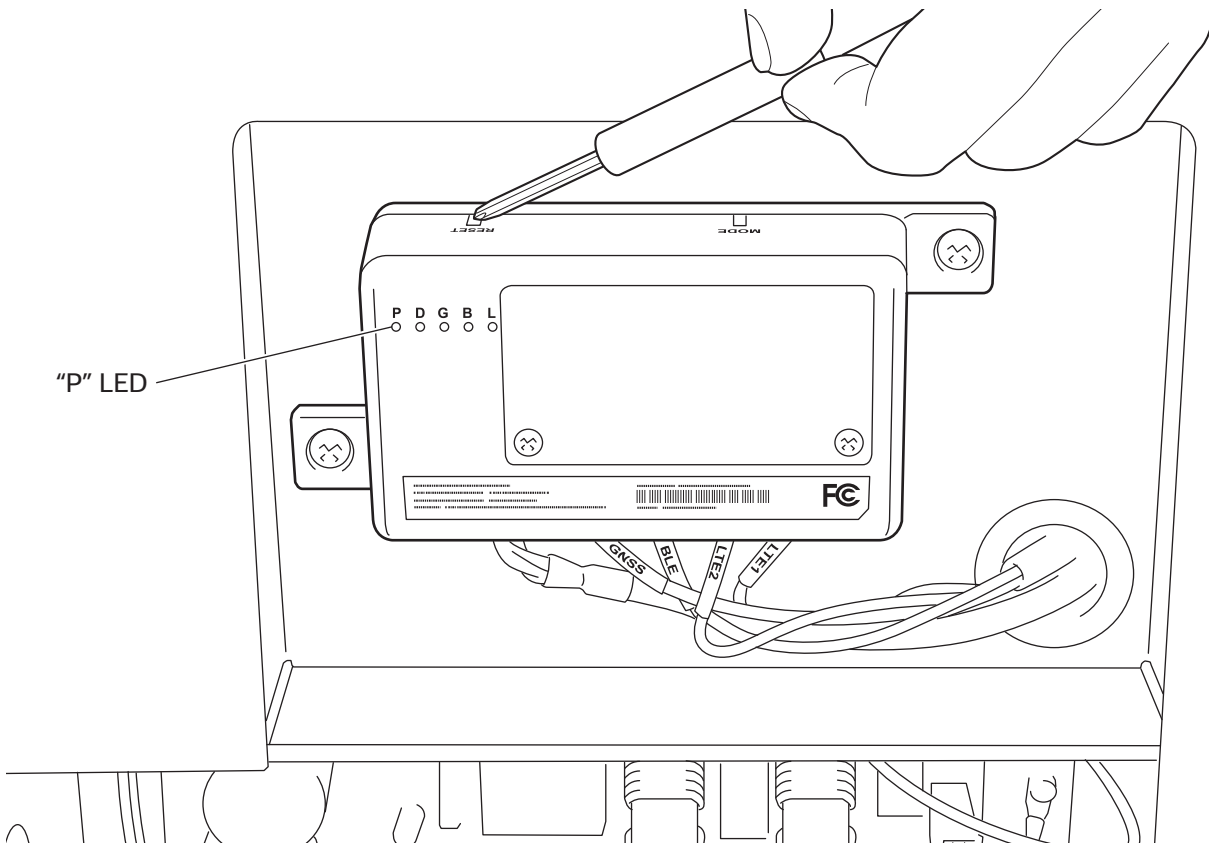

# TROUBLESHOOTING

## Initial Inspection

Before troubleshooting, the following inspection should be performed.

1. Check the voltage of the power source.  
115 V, 1 Phase, 60 Hz
2. Check the operation and condition of the fuse or circuit breaker in the power source.
3. Check the power cord. If dirty, wipe with a clean dry cloth. If damage or excess play is found, replace the cord.
4. Check the air filters. If dirty, clean the air filters as described in the operation manual. If damage is found, replace the filters.
5. Check the drain tank and empty the water. If damage is found, replace the tank.



### WARNING

- **Disconnect power supply from the unit before performing any service. Beware that some residual voltage may remain in the unit immediately after the power is disconnected. There is a risk of electric shock.**

## Self-Diagnostic Codes

When a self-diagnostic code is displayed on the LCD, the unit stops operation, relay contact RL07 for terminal OS-1 and OS2 is closed.

CODE	CONDITION	POSSIBLE CAUSE	SOLUTION
AL1	Alarm device 1 is activated	Alarm device connected to FA-1 and FA-2 of terminal block 1 is activated	<ol style="list-style-type: none"> <li>1. Check FA-1, FA-2 connection</li> <li>2. Identify and correct condition causing alarm</li> <li>3. Press CLEAR button to reset</li> </ol>
AL2	Alarm device 2 is activated	Alarm device connected to AL-1 and AL-2 of terminal block 1 is activated	<ol style="list-style-type: none"> <li>1. Check AL-1, AL-2 connection</li> <li>2. Identify and correct condition causing alarm</li> <li>3. Press CLEAR button to reset</li> </ol>
FL	Drain tank is full	Drain tank is full of water	<ol style="list-style-type: none"> <li>1. Empty tank</li> <li>2. Place tank back in unit</li> <li>3. Press CLEAR button to reset</li> </ol>
		Loose drain switch connection	<ol style="list-style-type: none"> <li>1. Reconnect switch</li> <li>2. Press CLEAR button to reset</li> </ol>
		Defective drain switch	<ol style="list-style-type: none"> <li>1. Replace switch</li> <li>2. Press CLEAR button to reset</li> </ol>
HP	High pressure protection is activated 8 times in 24 hours	Operating outside of temperature range	<ol style="list-style-type: none"> <li>1. Check operating temperature and humidity condition. The unit does not operate outside the condition range (See page 13)</li> <li>2. Press CLEAR button to reset</li> </ol>
		Air flow is blocked or restricted	<ol style="list-style-type: none"> <li>1. Clean air filters</li> <li>2. Ensure 24 inch (610 mm) clearance in front of air inlets, and air flow is not blocked or restricted</li> <li>3. Press CLEAR button to reset</li> </ol>
		Loose high pressure switch connection	<ol style="list-style-type: none"> <li>1. Reconnect switch</li> <li>2. Press CLEAR button to reset</li> </ol>
		Defective electronic expansion valve	<ol style="list-style-type: none"> <li>1. Replace valve</li> <li>2. Press CLEAR button to reset</li> </ol>
		Defective high pressure switch (short or open circuit)	<ol style="list-style-type: none"> <li>1. Replace switch</li> <li>2. Press CLEAR button to reset</li> </ol>
		Refrigerant is over charged	<ol style="list-style-type: none"> <li>1. Charge correct amount of refrigerant based on specifications or nameplate</li> <li>2. Press CLEAR button to reset</li> </ol>

## Self-Diagnostic Codes

When a self-diagnostic code is displayed on the LCD, the unit stops operation, relay contact RL07 for terminal OS-1 and OS2 is closed.

CODE	CONDITION	POSSIBLE CAUSE	SOLUTION
PU	Condensate pump safety switch is activated	Condensate pump stops due to kinks and/or blockage or improper routing of drain line	1. Remove blockage or kinks from drain line, or re-route drain line 2. Press CLEAR button to reset
		Missing or loose jumper connector	1. If the jumper connector is missing, insert one If connector is loose, reconnect it 2. Press CLEAR button to reset
		Defective condensate pump	1. Replace pump 2. Press CLEAR button to reset
CF	Cooling function failure occurs 3 times and following condition continues for 15 minutes Cooling operation: RTS - CTS2 < 9 °F (5 °C) Heating operation (except defrosting) ODS - CTS3 < 2 °F (1 °C) and ODS > 50 °F (10 °C)	Insufficient refrigerant or refrigerant leak	Repair leak and add refrigerant based on the weight listed on specifications or nameplate
		Defective compressor	1. Replace compressor 2. Press CLEAR button to reset
E1	RTS thermistor failure	Loose RTS thermistor connection	Reconnect thermistor
		Defective RTS thermistor (short or open circuit)	Replace thermistor
E2	ODS thermistor failure	Loose ODS thermistor connection	Reconnect thermistor
		Defective ODS thermistor (short or open circuit)	Replace thermistor
E3	CTS1 thermistor failure	Loose CTS1 thermistor connection	Reconnect thermistor
		Defective CTS1 thermistor (short or open circuit)	Replace thermistor
E4	CTS2 thermistor failure	Loose CTS2 thermistor connection	Reconnect thermistor
		Defective CTS2 thermistor (short or open circuit)	Replace thermistor
E5	CTS3 thermistor failure	Loose CTS3 thermistor connection	Reconnect thermistor
		Defective CTS3 thermistor (short or open circuit)	Replace thermistor

# Troubleshooting Chart

PROBLEM		POSSIBLE CAUSE	SOLUTION
Unit does not operate (No display on LCD screen)		Unit is not connected to power supply	Check connection to mains supply. Try plugging it in
		Main power is off	Check circuit breaker is on
		Ground fault protective breaker is tripped	Reset ground fault protective breaker
		LCDI Power cord is tripped	Reset power cord
		LCDI Power cord is damaged	Replace power cord
Unit stops or operates without producing cool or warm air after running for a period of time (LCD display is normal)	Function	Ambient temperature has reached set temperature and unit has stopped	Adjust set temperature
		Operating near minimum or maximum of operating temperature range	Review room environment
		Freeze protection has been activated due to low ambient temperatures, causing the compressor operation to stop	Wait for the system temperature to stabilize; this may take a few minutes. Once stabilized, compressor operation will resume
	LCD displays notification	OUTSIDE OPERATING RANGE	Check operating conditions on HEAT mode
		DEFROST	Operation resumes after defrosting is completed
	4-way valve LCD display shows HEAT mode, but operates in COOL mode	4-way valve failure	Replace coil on 4-way valve
	Motor	Fan motor malfunction See "Inspection of Parts" on page 55 and 56	Replace fan motor
Abnormal rotation of indoor or outdoor fan motor		Replace fan motor	

# Troubleshooting Chart

PROBLEM		POSSIBLE CAUSE	SOLUTION
Unit stops or operates without producing cool or warm air after running for a period of time (LCD display is normal)	Compressor	Compressor malfunction See "Inspection of Parts" on page 57	Replace compressor
		Low voltage	Repair power supply
		Capacitor malfunction See "Inspection of Parts" on page 54	Replace capacitor
		Resistance of compressor coil is zero or infinity due to a short or open circuit	Replace compressor
		If power supply, capacitor and compressor are normal, there is a problem with relay board	Replace relay board
	Relay Board	If fan motor and compressor are normal, there is a problem with relay board	Replace relay board
	Others	Improper duct connection (Optional accessories)	Adjust duct connection
		Clogged air filter	Clean air filter
		Dirt or clogged indoor or outdoor heat exchanger	Clean heat exchanger
		Crushed fins	Repair or replace heat exchanger
		Frosting on the refrigerant line caused due to blockage	Service refrigeration system
Insufficient refrigerant		Check for leaks, repair, and add refrigerant based on the weight listed on specifications or nameplate	
Water leaking from unit	Tank is not correctly installed	Position tank	
	Tank inlet or drain port is clogged	Unclog tank inlet or drain port	
	Cracks in drain pan	Replace drain pan	
	Drain hose is blocked or damaged (Optional drain pump)	Unblock or repair drain hose	
	Reversed air flow from drain hole due to excessive negative pressure inside of unit	Clean air filters	

# Troubleshooting Chart

PROBLEM	POSSIBLE CAUSE	SOLUTION
Abnormal noise or vibration	Fan interference	Adjust interfering section
	Fan deformation	Replace fan
	Loose compressor nuts	Tighten nuts
	Pipe interference	Adjust pipe
	Loose panel screws	Tighten screws
Communication module* not working properly	"P" LED indicator on communication module is off due to AC power is not plug in and communication module battery switch at the OFF position	Plug in AC power or set communication module battery switch to ON position
	When the "L" LED indicator located on the communication module is off, it may be due to poor or no cellular (LTE) signal, connection or unit is located in an area with high signal interference or an area that restricts LTE signal	RESET communication module
	When the "G" LED indicator located on the communication module is off, it may be due to poor or no navigation (GNSS) signal, connection or unit is located in an area with high signal interference or an area that restricts GNSS signal	To reset, press reset button and confirm "P" LED indicator blinks one time and stays on

\* Communication module is optional.

# Inspection Before Disassembly

## 1. Inspection of plate fins on heat exchangers

Remove air filters and check plate fins for any dirt, dust, lint, or debris that may cause insufficient cooling or heating performance. If necessary, clean the plate fins.

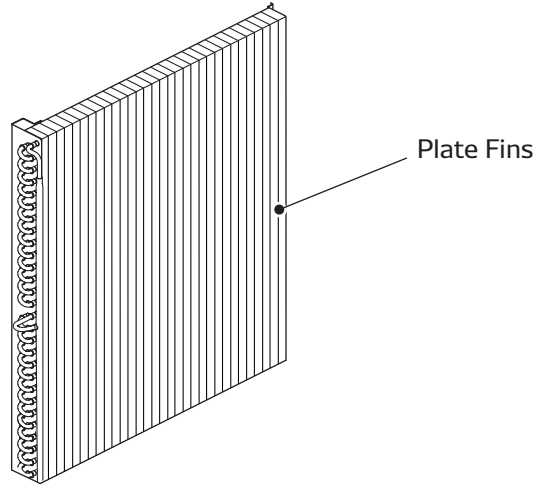

## 2. Inspection of cooling or heating capacity performance

Measure the difference in air temperature between the inlet of the indoor heat exchanger and the cool/ heat air vent. If the difference is out of the range of the graph on page 14 and 15, proceed with the solution of "Unit stops or operates without producing cool or warm air after running for a period of time" on page 30 and 31.

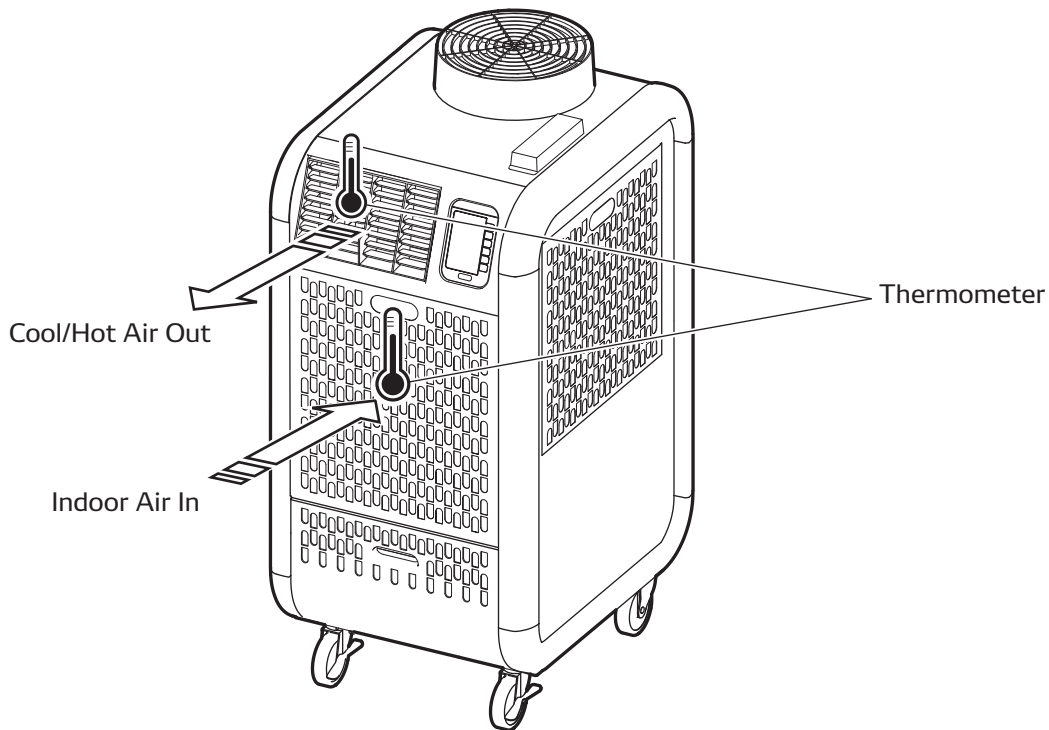

# DISASSEMBLY



## WARNING

- **Electrical work must be performed by qualified electrical personnel. Failure to use qualified electrical personnel for electrical work may cause fire, electric shock, injury, malfunction or water leaks.**
- **Use genuine MovinCool parts for servicing. Non-genuine parts may cause fire, electric shock or water leaks.**
- **Disconnect power supply from the unit before performing any service. Beware that some residual voltage may remain in the unit immediately after the power is disconnected. There is a risk of electric shock.**

# Structure Parts

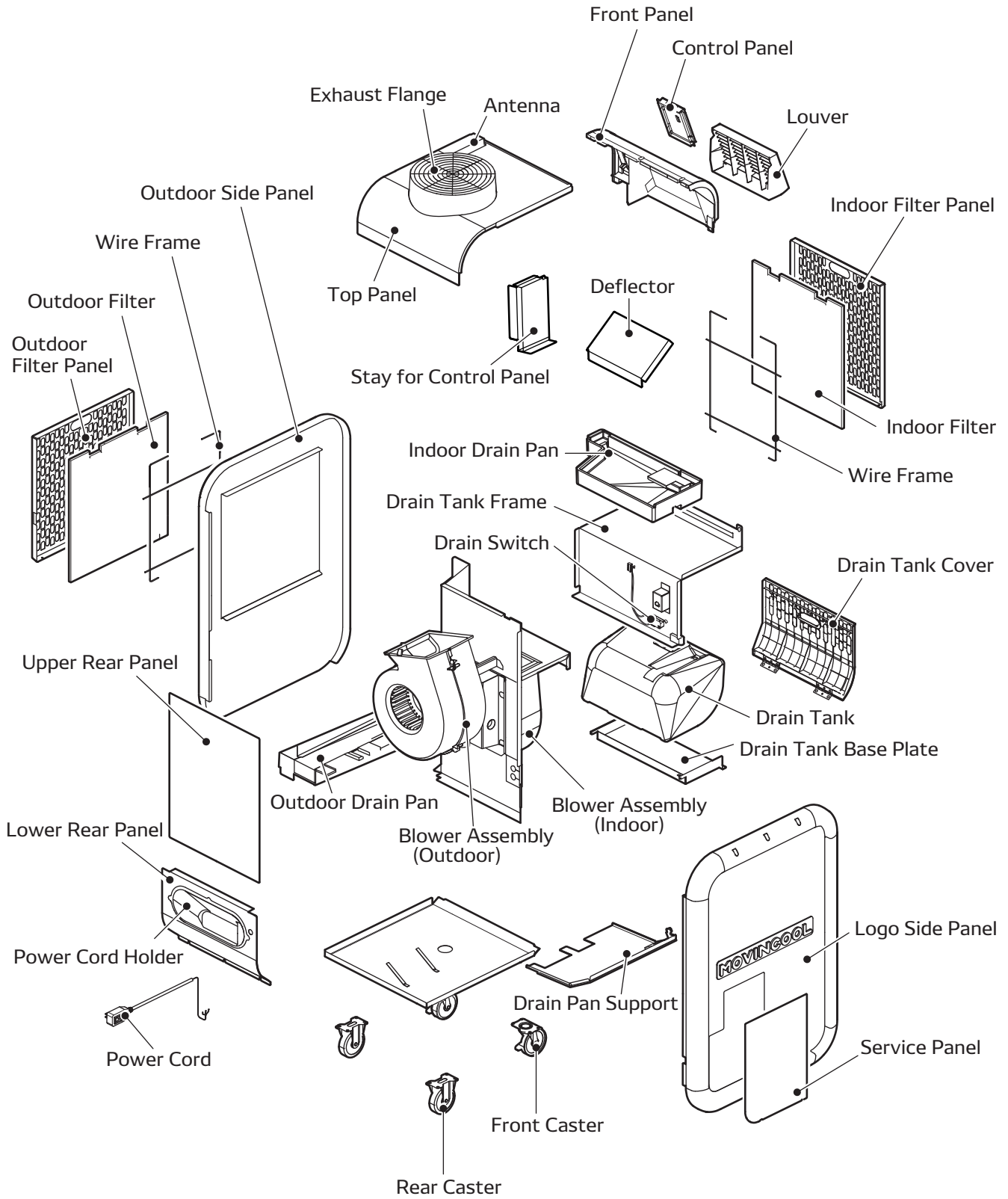

## Removal of Panels

1. Open the drain tank cover and remove the tank.

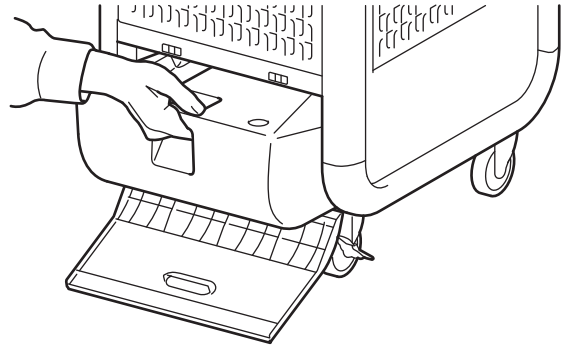

2. Remove the indoor and outdoor filter panels.

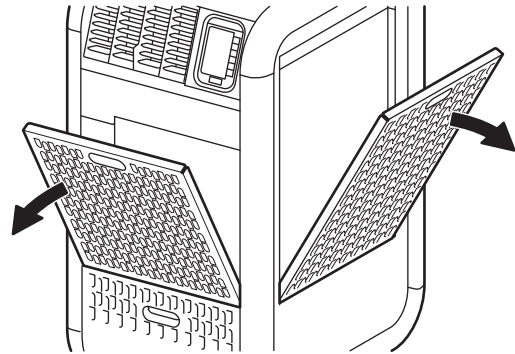

3. Loosen the bottom two (2) screws and remove the other seven (7) M4 x L10 screws. Move the service panel upward and remove it from the logo side panel.

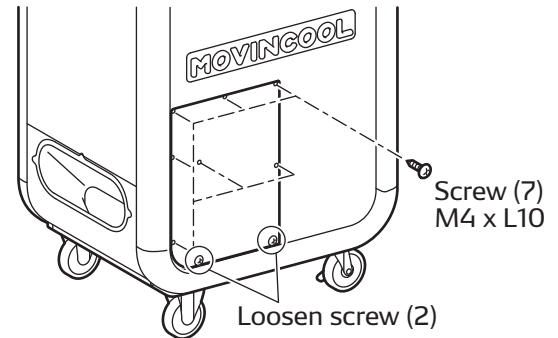

4. Loosen the center bottom screw (1) and remove the other seven (7) M4 x L10 screws. Move the upper rear panel upward and remove it.

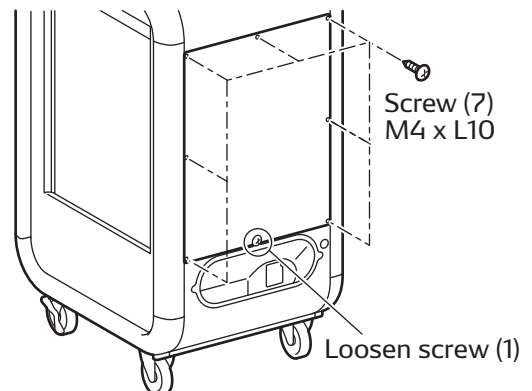

## Removal of Panels

5. Power cord holder can be removed from the lower rear panel. Remove the four (4) M4 x L10 screws and remove the power cord holder.

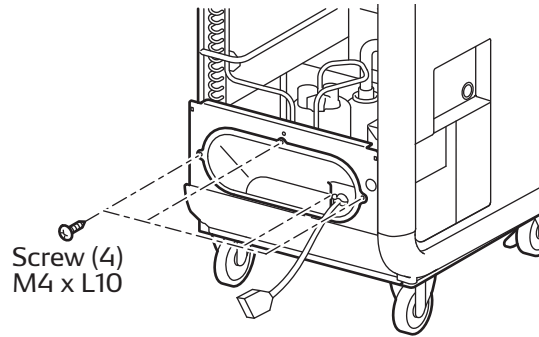

6. Remove the thirteen (13) M4 x L10 screws and one (1) M4 x L12 screw. Next remove the logo side panel.

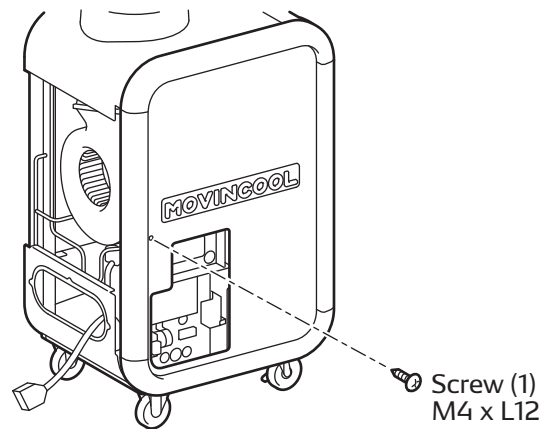
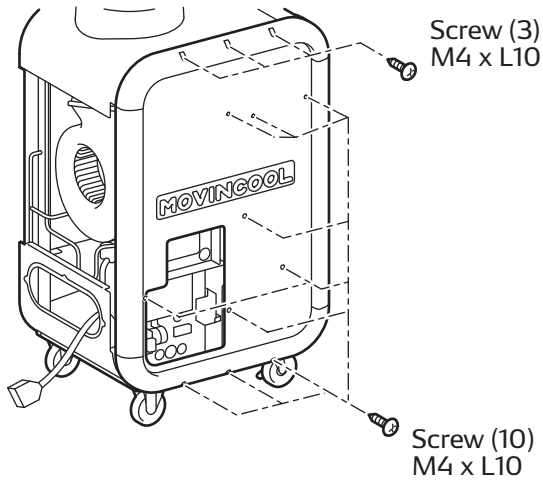

## Removal of Panels

7. Remove the eight (8) M4 x L10 screws and the six (6) M4 x L12 screw. Next remove the outdoor side panel.

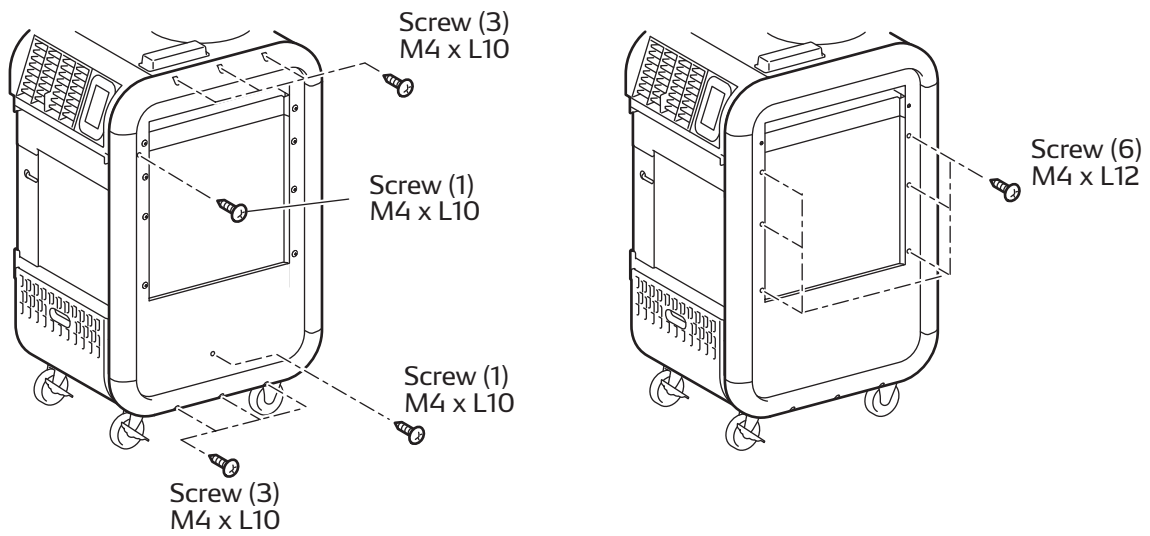

8. Disconnect the CN1 and CN2 connectors from the control board.

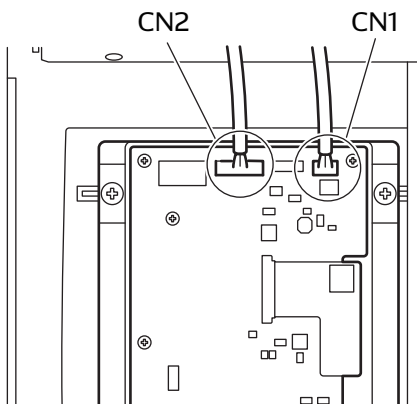

9. Remove the five (5) M4 x L10 screws and remove the upper front panel.

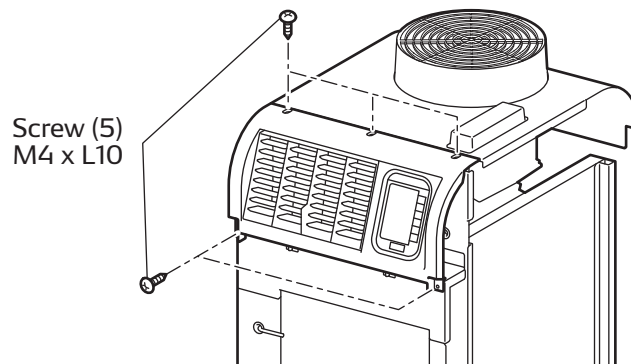

# Removal of Panels

10. To remove the top panel, unfasten the wire assembly on the control box.

- a) Remove the tape and the bubble-wrap from the wire assembly on the control box as shown.

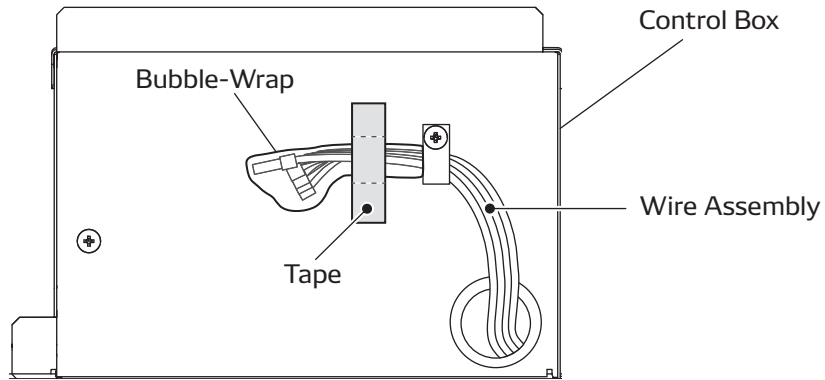

- b) Remove the screw from the control box. Discard the clip which secured the wire assembly. Restore the screw in its original place. The screw is used when installing an optional communication module.

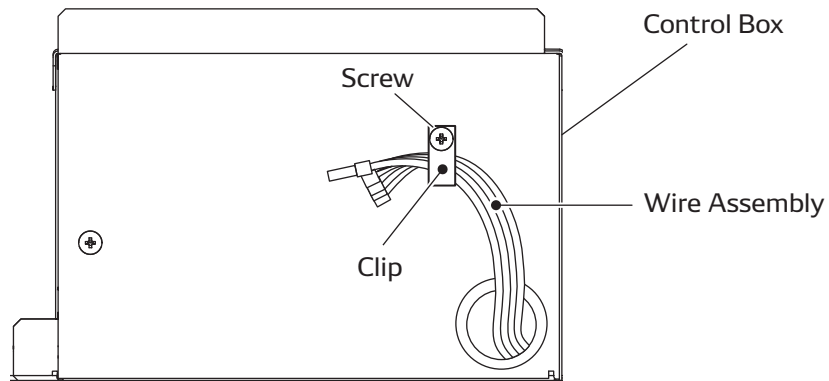

11. Remove the four (4) M4 x L12 screws and the two (2) M4 x L10 screws, then remove the top panel.

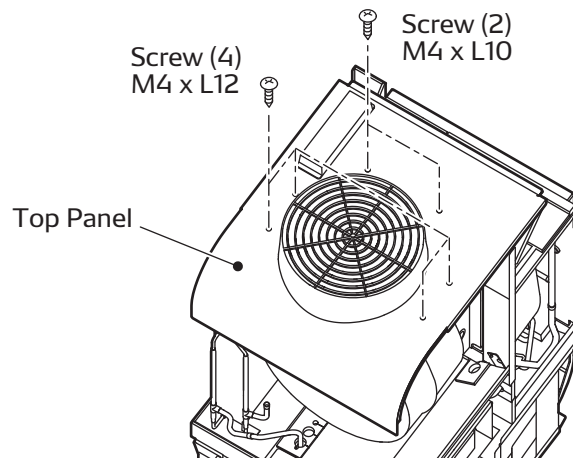

## Removal of Panels

12. Remove the two (2) M4 x L10 screws and remove the deflector.

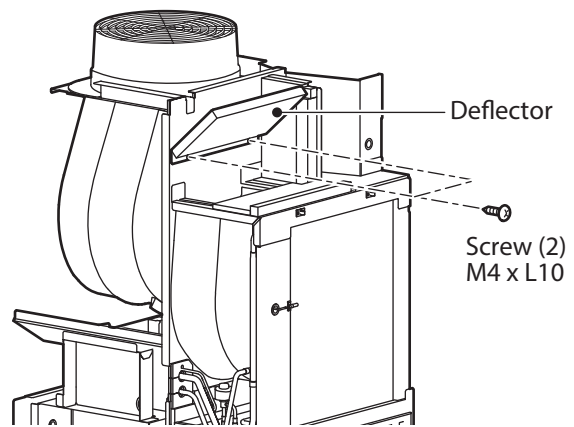

13. Remove the one (1) M4 x L10 screw as shown.

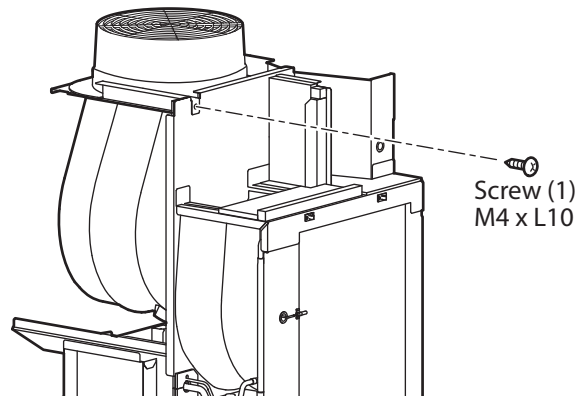

14. Remove the one (1) M4 x L10 screw as shown.

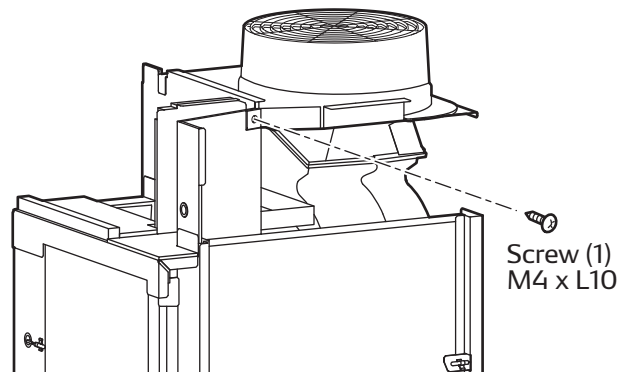

15. Remove the one (1) M4 x L10 screw from the fan casing, and then remove the exhaust flange with the bracket.

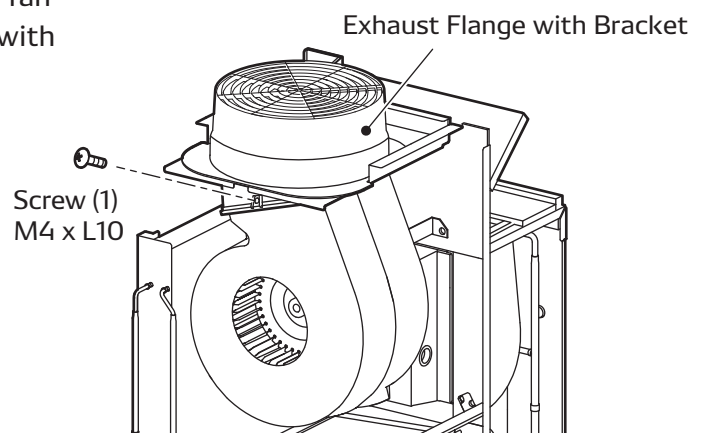

## Removal of Louver

Louver can be removed from the upper front panel by releasing either of the lock tabs from notches.

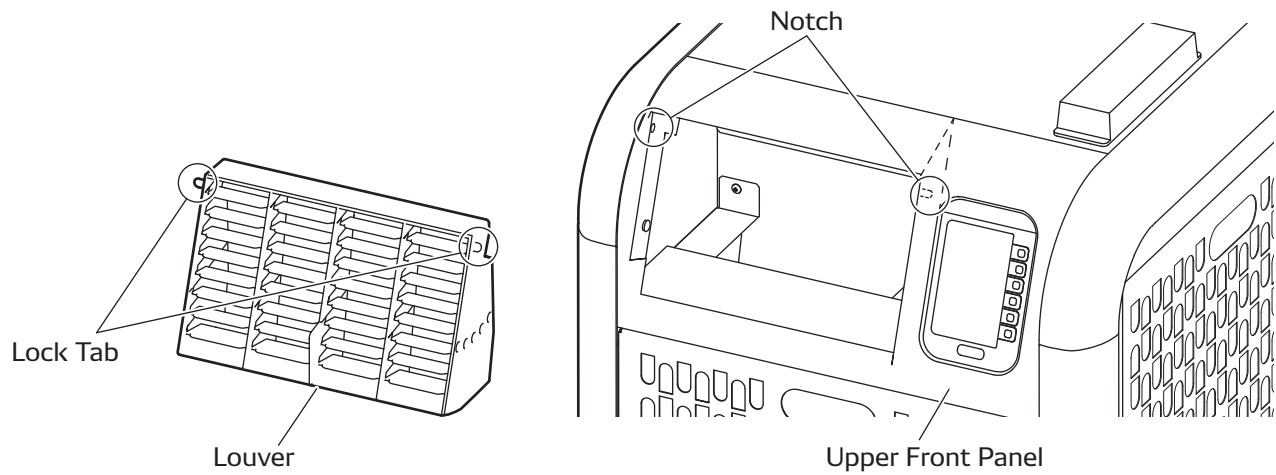

1. Lift the bottom of the louver upward.

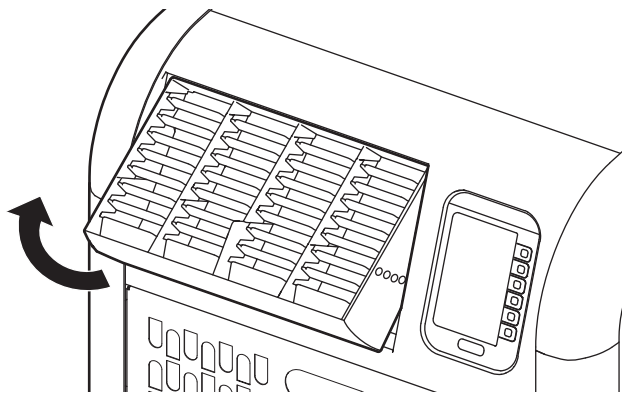

2. Slide the louver a little to the right or left so as to release the lock tab from the notch and pull out the louver.

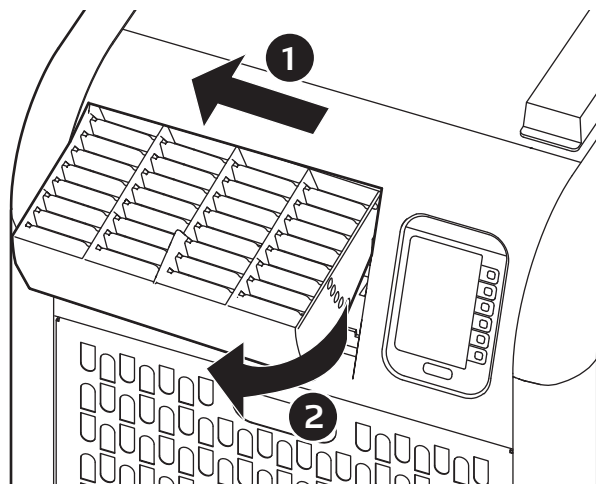

# Removal of Bumper

Logo side panel

1. Remove the three (3) M4 x L12 screws and remove the bumper **A**
2. Remove the three (3) M4 x L12 screws and remove the bumper **B**
3. Remove the three (3) M4 x L12 screws and remove the bumper **C**
4. Remove the two (2) M4 x L12 screws and remove the bumper **D**

Note:

- To remove bumper **C** or **D**, bumper **A** and **B** should be removed first.

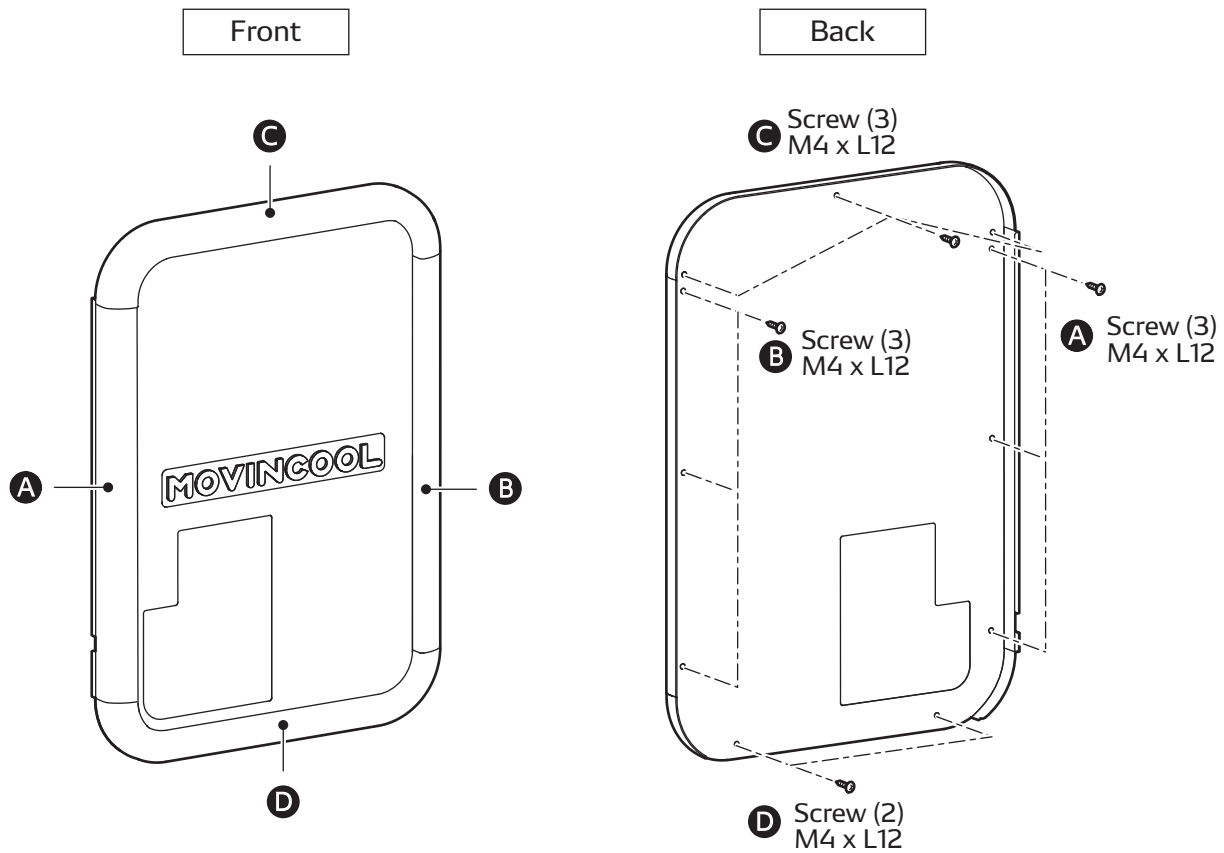

# Removal of Bumper

## Condenser side panel

1. Remove the three (3) M4 x L12 screws and remove the bumper **A**
2. Remove the three (3) M4 x L12 screws and remove the bumper **B**
3. Remove the three (3) M4 x L12 screws and remove the bumper **C**
4. Remove the two (2) M4 x L12 screws and remove the bumper **D**

### Note:

- To remove bumper **C** or **D**, bumper **A** and **B** should be removed first.

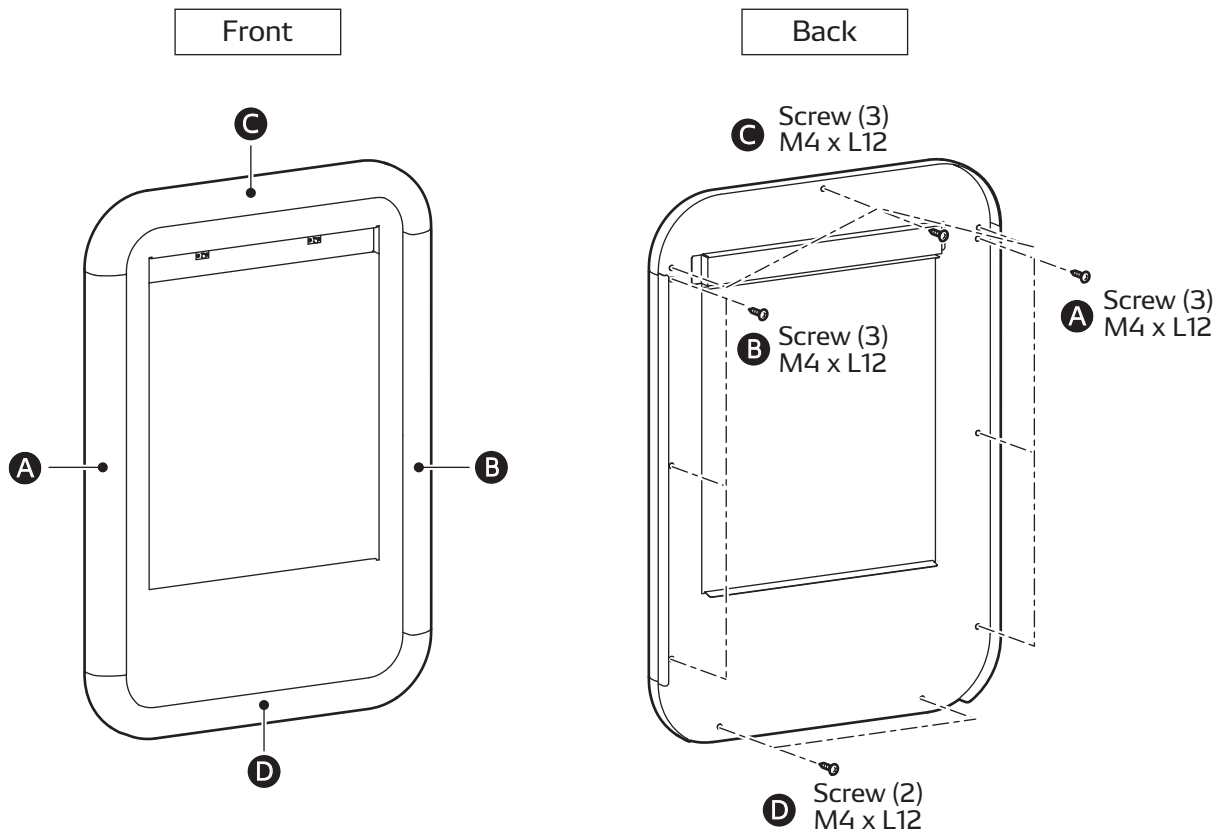

# Removal of Electrical Parts

## 1. Control box

- a) Remove the service panel from the logo side panel. (See step 3 on page 36)
- b) Remove the following number of screws and remove each electrical part from the control box.
  - Terminal block 1: two (2) screws
  - Terminal block 2: two (2) screws
  - Compressor motor capacitor: one (1) screw
  - Drain switch: two (2) screws

【Unit Serial No. Range: 0125\*\*\*\*D12 to Present】

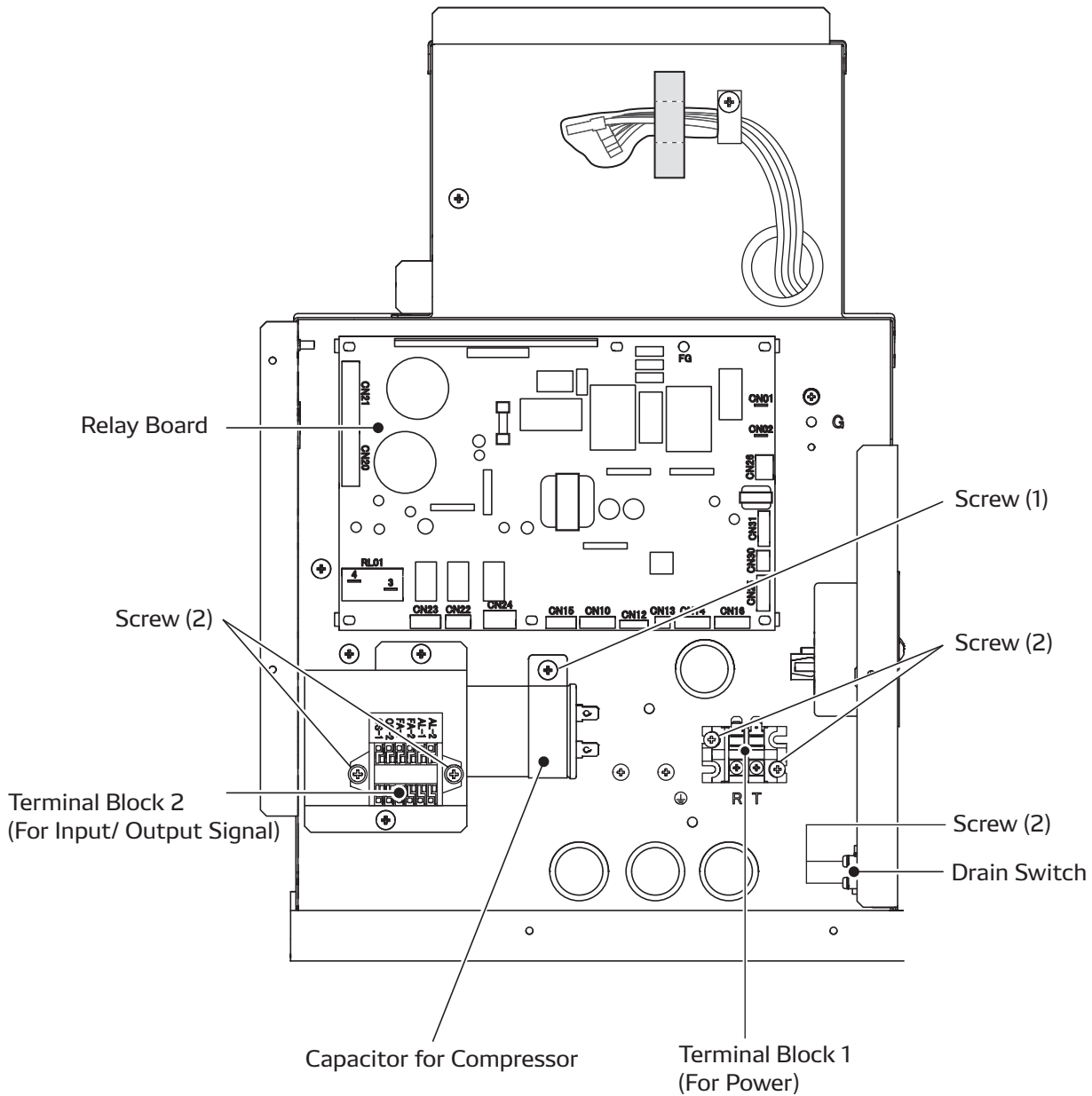

1. Control box

- a) Remove the service panel from the logo side panel. (See step 3 on page 36)
- b) Remove the following number of screws and remove each electrical part from the control box.
  - Terminal block 1: two (2) screws
  - Terminal block 2: two (2) screws
  - Compressor motor capacitor: one (1) screw
  - Drain switch: two (2) screws

【Unit Serial No. Range: 1224\*\*\*\*D12】

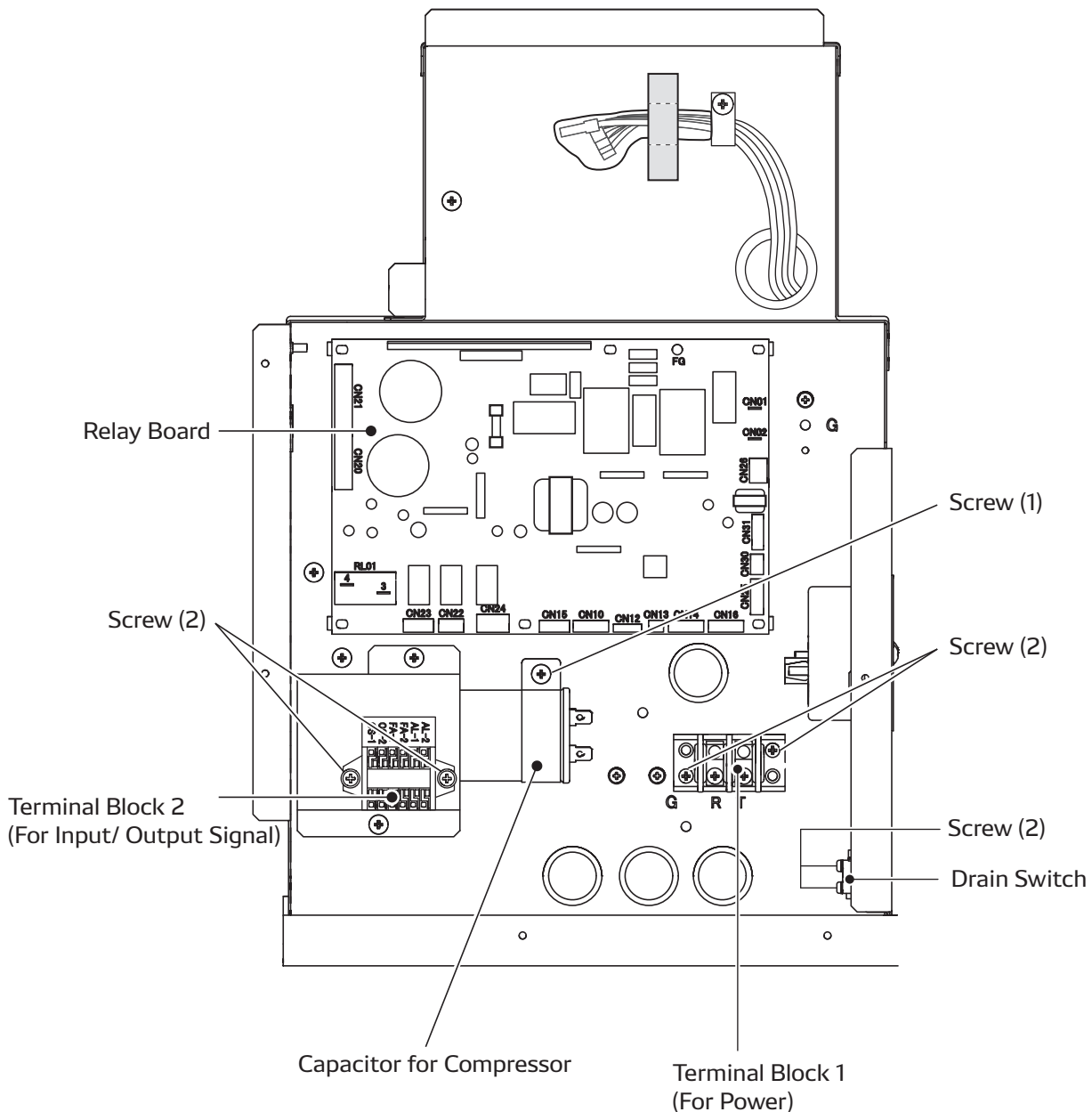

# Removal of Electrical Parts

## 2. Relay Board

- a) Remove the six (6) supports with needle-nose pliers and remove relay board from the control box.

Note:

- Be careful not to damage the relay board.
- b) Disconnect the fifteen (15) connectors from the relay board.

CN20 (Red, Blue, Brown, Orange, White)  
To Outdoor Fan Motor

CN21 (Red, Blue, Brown, Orange, White)  
To Indoor Fan Motor

Support (6)

CN01 (Red)  
To Terminal Block 1  
(R for Power)

CN02 (Black)  
To Terminal Block 1  
(T for Power)

CN30 (White, Black, Red)  
To Control Board

CN25 (White, Yellow, Orange,  
Blue, Red)  
To Electronic Expansion Valve

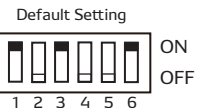

RL01-4 (Black)  
To Terminal Block  
(T for power)

RL01-3 (Black)  
To Compressor OLC2

CN23 (Black, White)  
To Drain Pan Heater

CN22 (Black, Blue)  
To 4-Way Valve

CN24 (White, Black)  
To Terminal Block 2  
(OS1, OS2, for Warning Device)

CN10 (Black)  
To RTS, ODS,CTS1,CTS2,CTS3 Thermistors

CN15 (White, Yellow, Brown)  
To Terminal Block 2  
(AL-1, AL-2, FA-1, FA-2 for Alarm Device)

CN14 (Yellow, Brown, Blue, Orange)  
To Drain Switch,  
Optional Condensate Pump

CN13 (Red)  
To High Pressure Switch

## Removal of Electrical Parts

3. Control Panel (see "Removal of Panels")
  - a) Follow step 2, 3, 4, 6, and 7 in "Removal of Panels" section.

- b) Disconnect the CN1 and CN2 connectors from the control board.

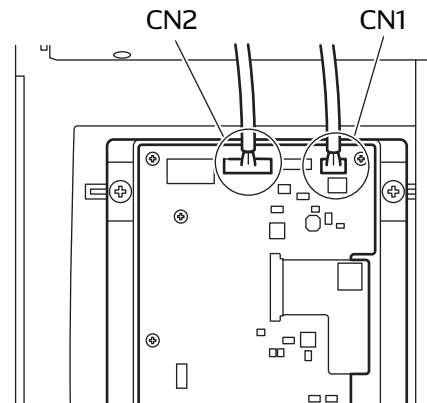

- c) Remove the five (5) M4 x L10 screws and remove the upper front panel.

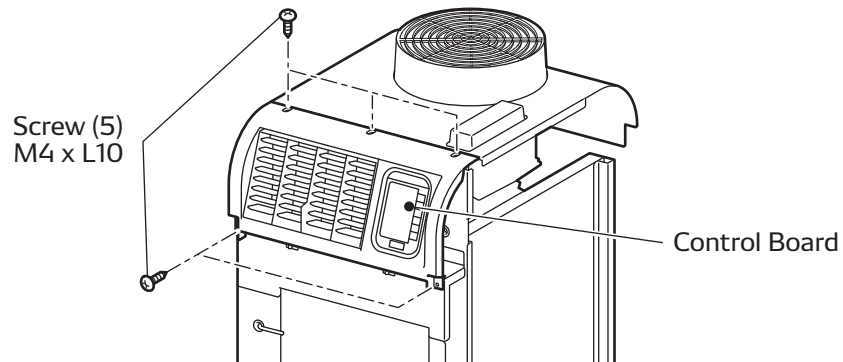

- d) Remove the four (4) M4 x L12 screws and remove the control panel from the upper front panel.

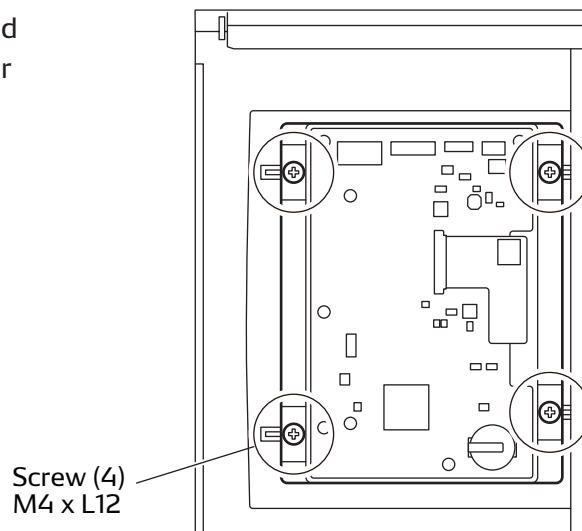

## Removal of Antenna

1. Follow step 2, 3, 4, and 7 in "Removal of Panels" section.
2. To remove the antenna, unfasten the wire assembly on the control box.
  - a) Remove the tape and the bubble-wrap from the wire assembly on the control box as shown.

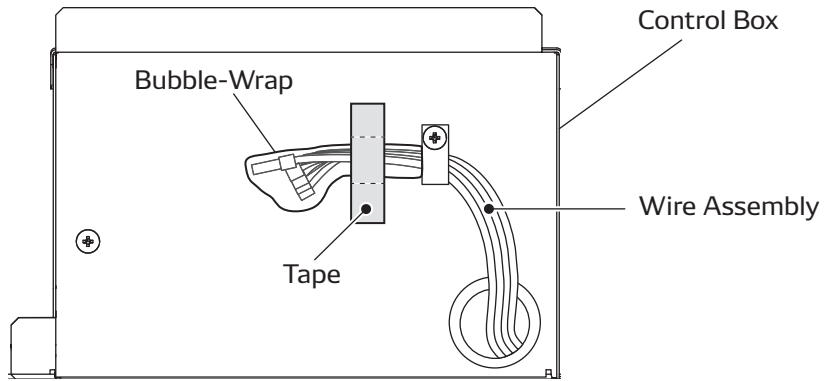

- b) Remove the screw from the control box. Discard the clip which secured the wire assembly. Restore the screw in its original place. The screw is used when installing an optional communication module.

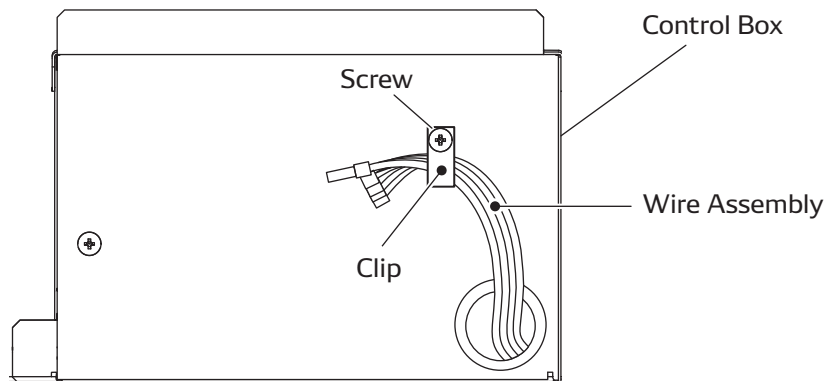

## Removal of Antenna

3. Remove the two (2) M4 x L10 screws from underneath the top panel to detach antenna from the top panel.

Note:

- Do not try to remove antenna wires from the antenna housing, this may cause damage to the antenna module.

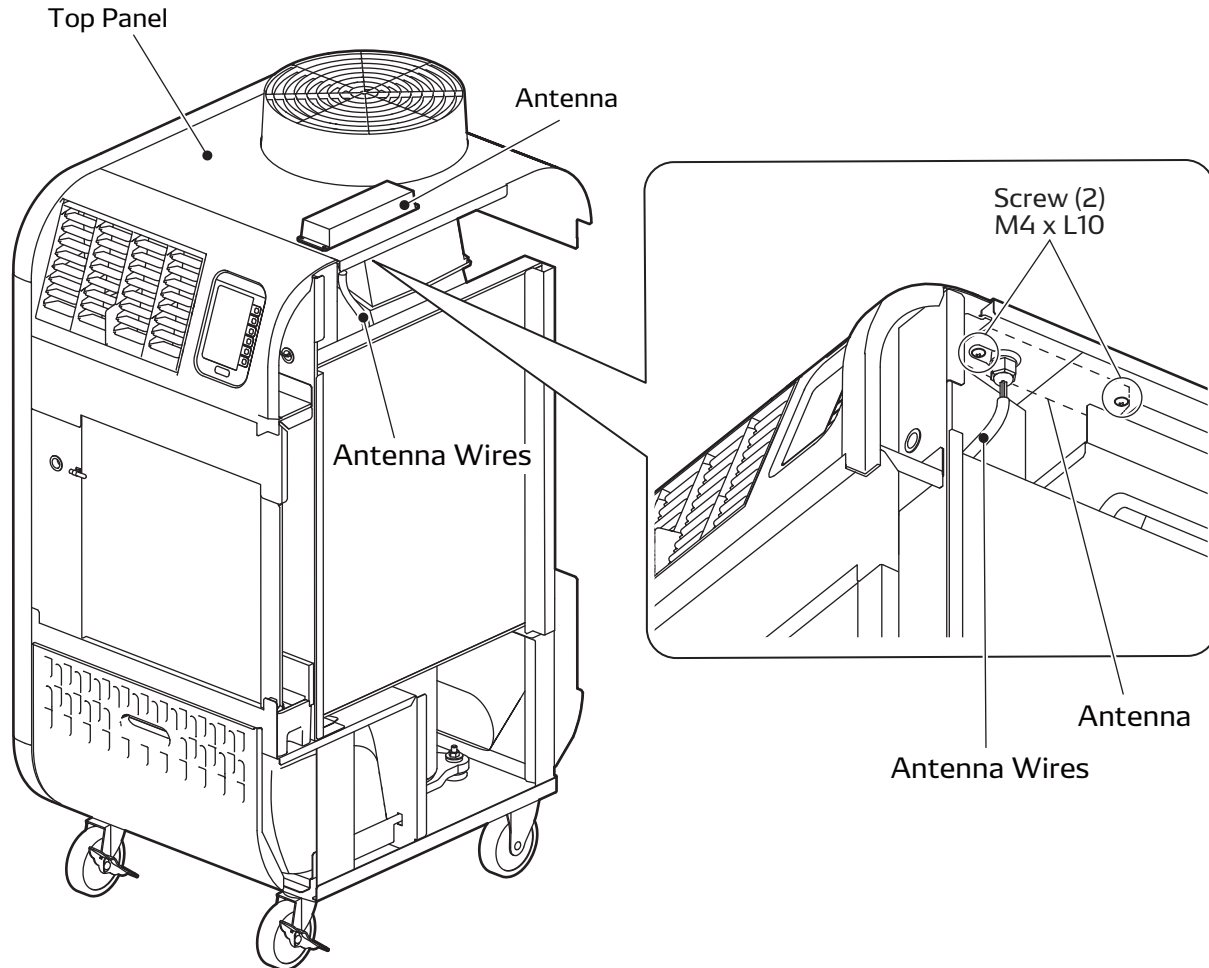

# Removal of Blower Assembly

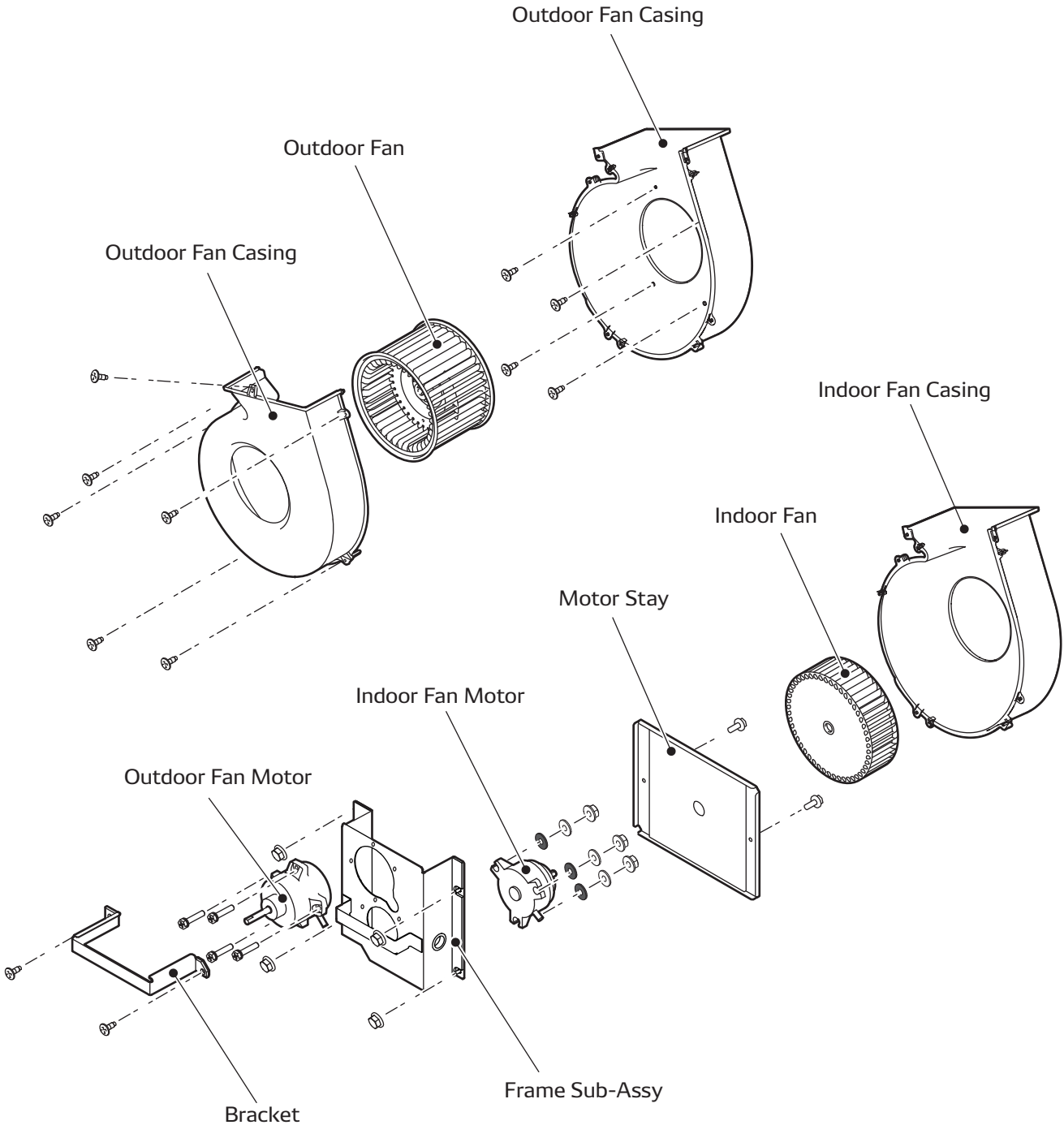

## Removal of Blower Assembly

1. Remove the five (5) M4 x L12 screws and remove the half outdoor fan casing.

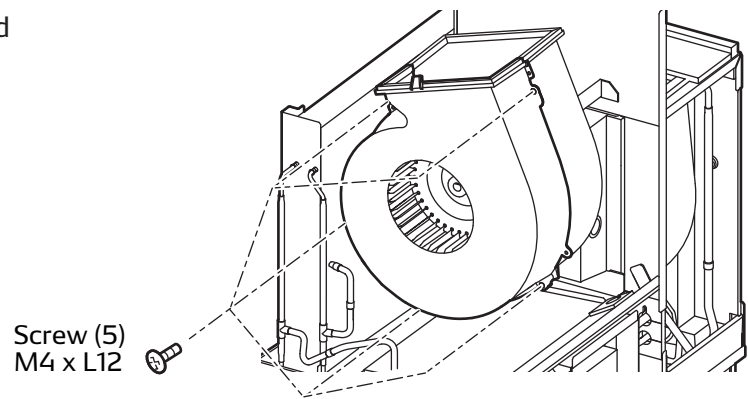

2. Loosen the set screw and remove the outdoor fan.

Note:

- When reinstalling the outdoor fan, fasten the set screw at the torque of  $12.6 \pm 1.3$  ft·lbf ( $17.1 \pm 1.7$  N·m).

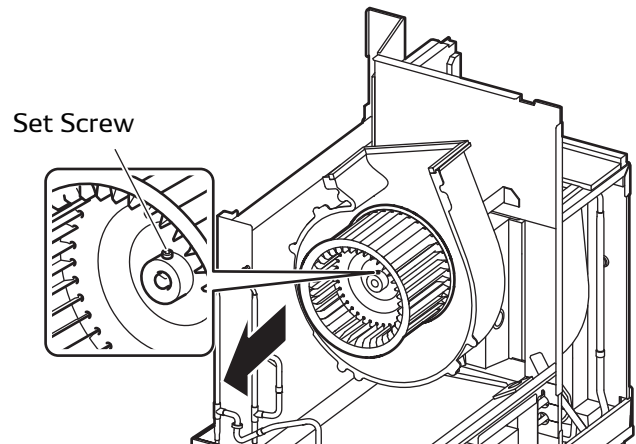

3. Remove the four (4) M4 x L10 screws and remove the other half of the outdoor fan casing.

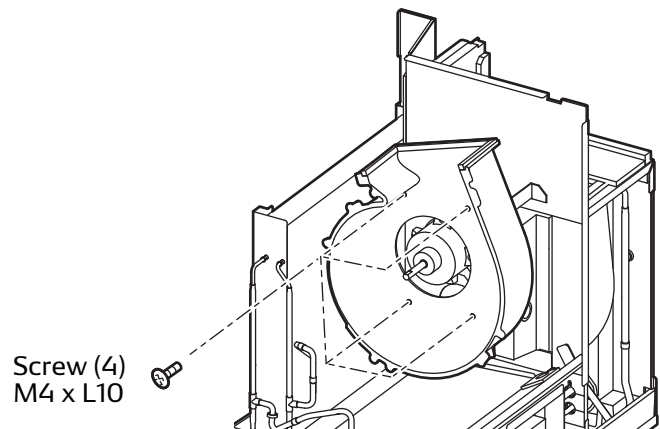

4. Remove CN20 connector (for outdoor fan motor) and CN21 connector (for indoor fan motor) from the relay board.

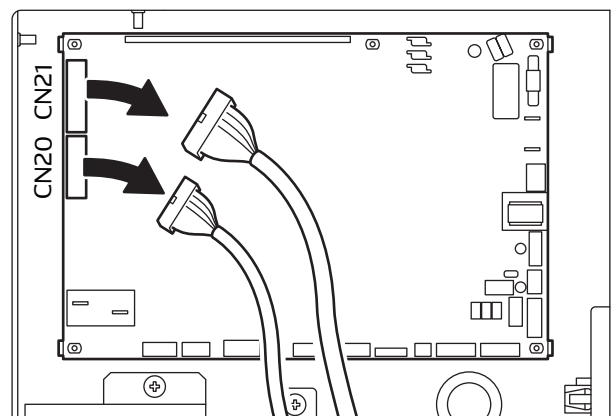

## Removal of Blower Assembly

5. Remove the four (4) nuts and remove the fan motor assembly.

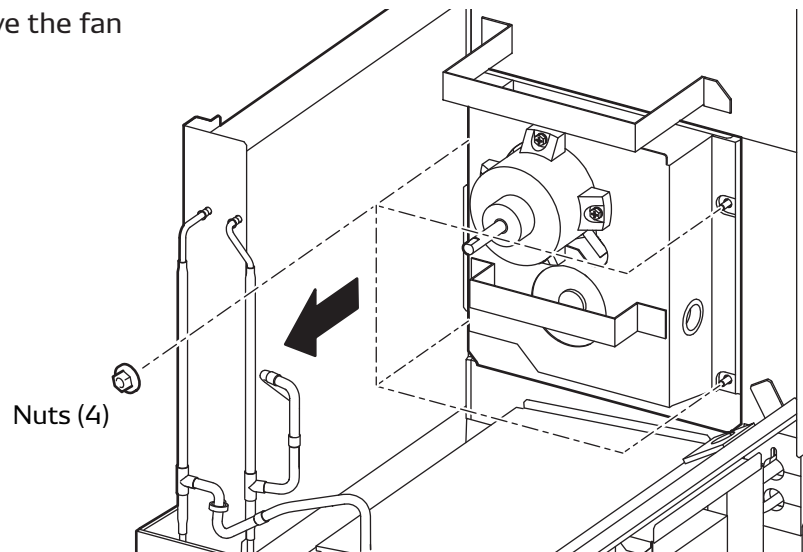

6. Loosen the set screw and remove the indoor fan.

Note:

- When reinstalling the indoor fan, fasten the set screw at the torque of  $5.5 \pm 0.5$  ft·lbf ( $7.4 \pm 0.7$  N·m).

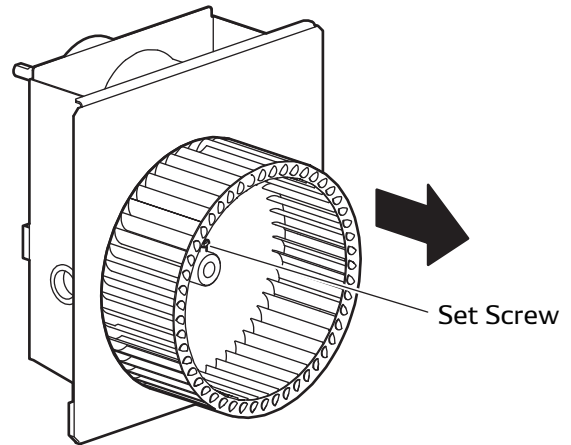

7. Remove the two (2) M4 x L10 screws and remove the motor stay.

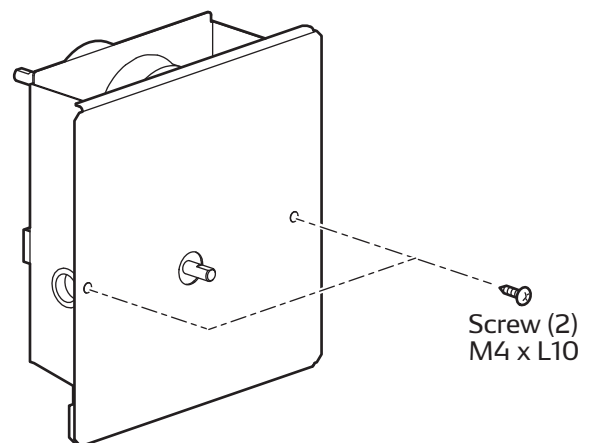

# Removal of Blower Assembly

8. Remove the three (3) nuts, iron washers and rubber washers. Next remove the indoor fan motor.

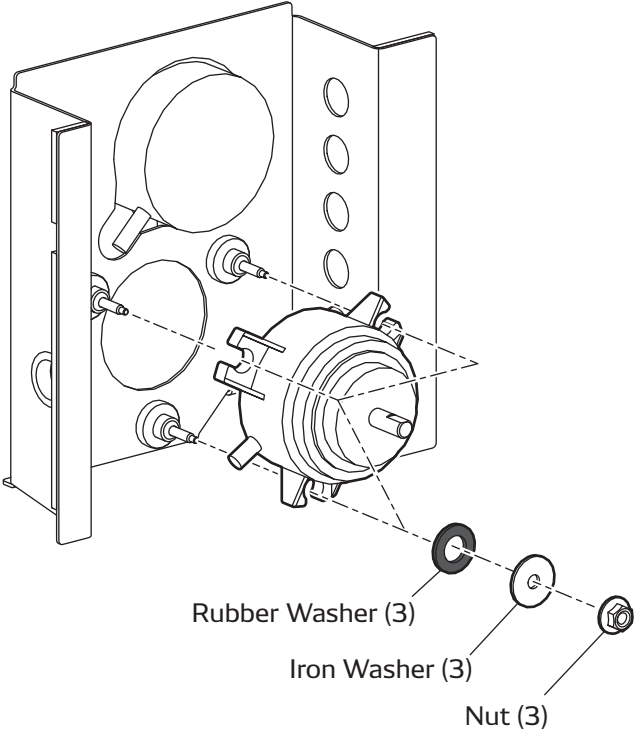

9. Remove the four (4) M6 x L30 bolts and remove the outdoor fan motor.

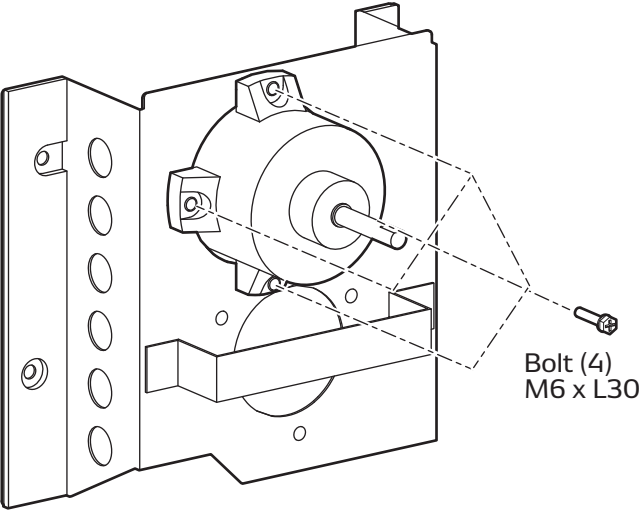

# INSPECTION OF PARTS

## Capacitor

### 1. Ohmmeter method

Set the ohmmeter to the 10M range. Place the two probes against the two terminals of the capacitor. At first, the ohmmeter should indicate a small value, and then the reading should gradually increase towards infinity. This indicates that the capacitor is charging. If the reading indicates infinity immediately (open) or the ohmmeter fails to move from 0 (short), replace the capacitor.

### 2. Capacitance tester

If the tester indicates the capacitance is less than 90% of the value below, replace the capacitor.

- Voltage: 450VAC
- Rating Capacitance: 40  $\mu$ F

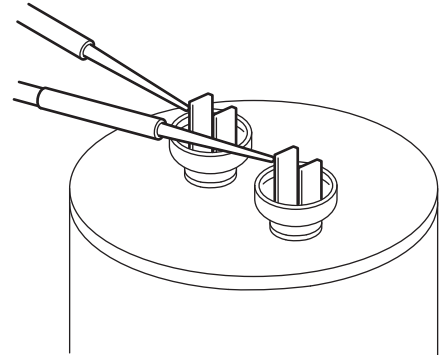

## WARNING

- Always discharge the capacitor before and after testing. If not, it may cause electric shock, damage to test equipment or malfunction.

## Drain Switch

Check for continuity between terminal 1 and terminal 2 when drain switch is pressed. If continuity does not exist, replace drain switch.

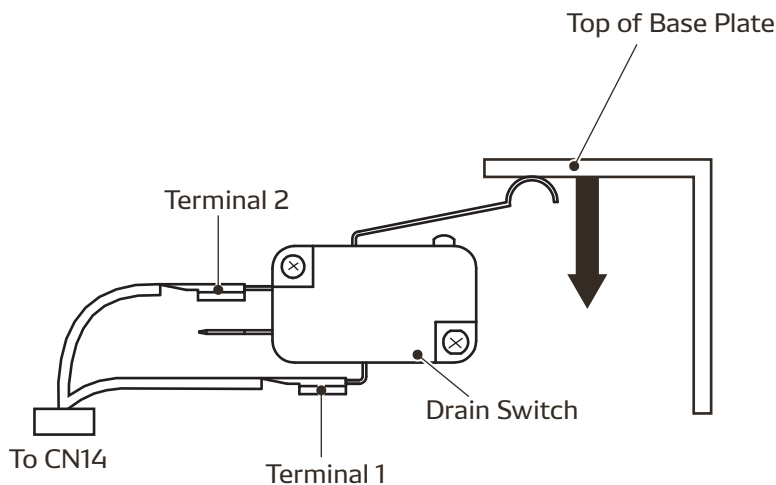

# Indoor Fan Motor

Check the resistance values across the two pins listed in the table below on the 8-pin indoor fan motor connector with an ohm-meter.

If the measured values are outside of the acceptable values, then replace the indoor fan motor.

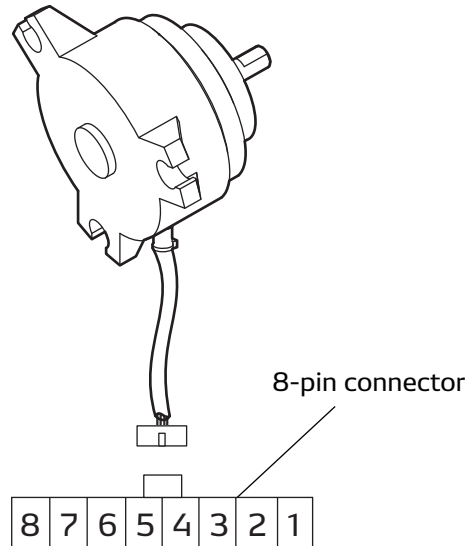

Connector Pin No.	8	7	6	5	4	3	2	1
Wire Color	White	Orange	Brown	Blue	X	X	X	Red

	Polarity of Tester		Acceptable Value
	⊕	⊖	
Connector Pin No.	1	5	1M ohm or more
		6	1M ohm or more
		7	1M ohm or more
	5	6	1M ohm or less
		7	1M ohm or less
	6	7	1M ohm or less

# Outdoor Fan Motor

Check the resistance values across the two pins listed in the table below on the 7-pin outdoor fan motor connector with an ohm-meter.

If the measured values are outside of the acceptable values, then replace the outdoor fan motor.

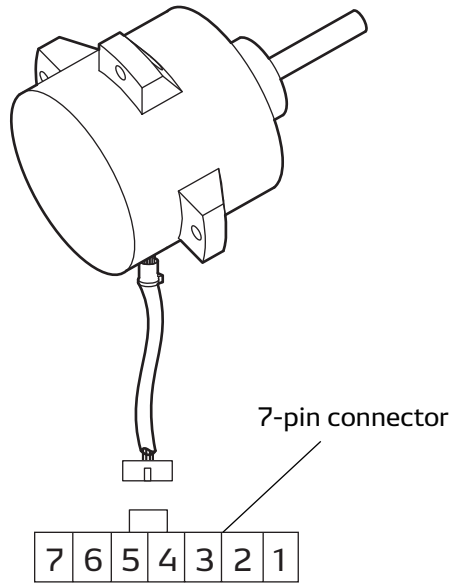

Connector Pin No.	7	6	5	4	3	2	1
Wire Color	White	Orange	Brown	Blue	X	X	Red

	Polarity of Tester		Acceptable Value
	⊕	⊖	
Connector Pin No.	1	4	1M ohm or more
		5	1M ohm or more
		6	1M ohm or more
	4	5	1M ohm or less
		6	1M ohm or less
	5	6	1M ohm or less

# Compressor

1. Remove the nut and remove the cover from the compressor.

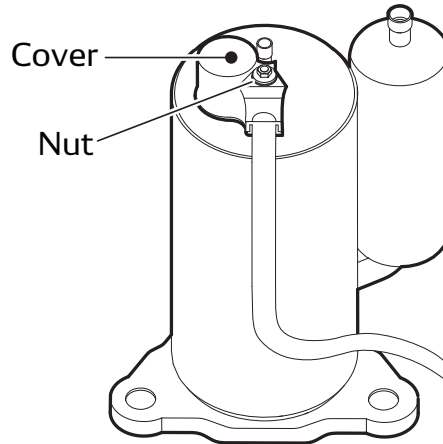

## 2. Compressor Motor

Disconnect the terminals: C, R and S from the compressor motor and check resistance across the terminals: Between terminals at 68 °F (20 °C)

- R-C Approx. 0.796 ohm
- C-S Approx. 2.693 ohm

If the measured resistance is not equal to these standard values, replace the compressor.

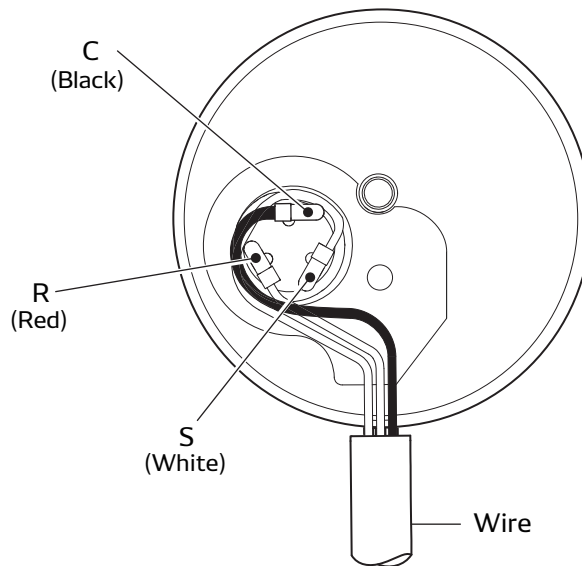

# Thermistor

Check the resistance value between pin 1 and pin 2 of thermistor connector with an ohm-meter.

- RTS: Room thermistor
- CTS1: Compressor pipe thermistor
- CTS2: Evaporator pipe thermistor
- CTS3: Condenser pipe thermistor
- ODS: Outdoor thermistor

If the measured value is outside of the thermistor specification, replace the thermistor.

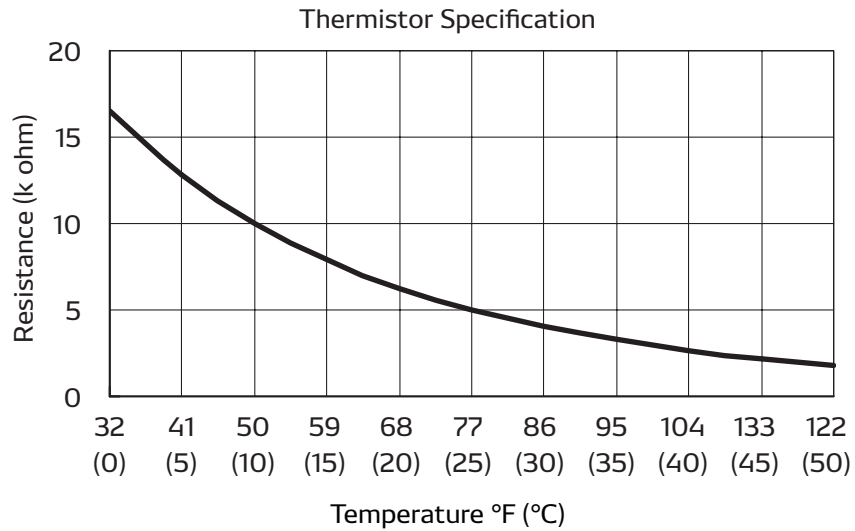
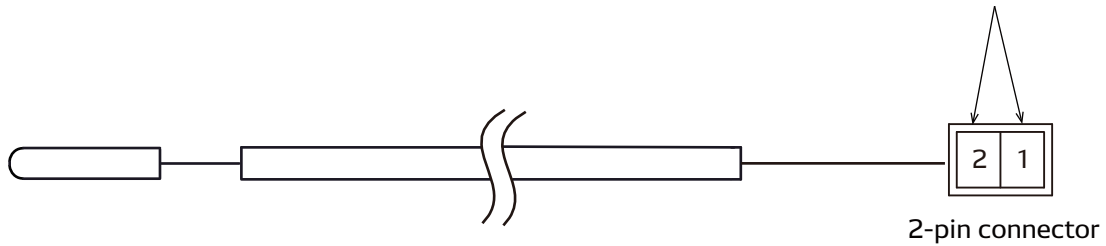

# High Pressure Switch

Check for continuity between pin 1 and pin 2 of the connector. If continuity does not exist, replace high pressure switch.

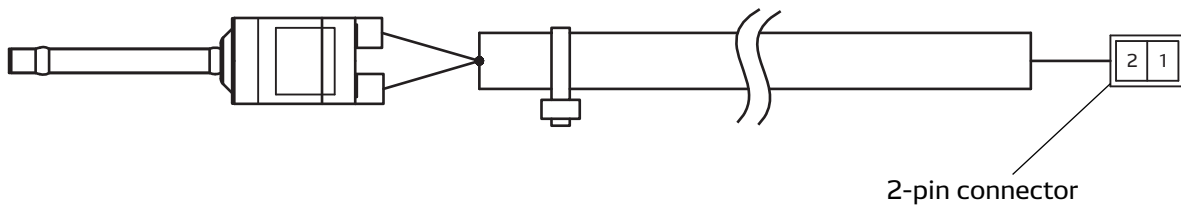

## Electronic Expansion Valve Control Coil

Check the resistance across the connector pins of the electronic expansion valve control coil.

- Between Blue and Red
- Between Orange and Red
- Between Yellow and Red
- Between White and Red

If the coil resistance is not between 26 to 56 ohm at room temperature, replace the electronic expansion valve control coil.

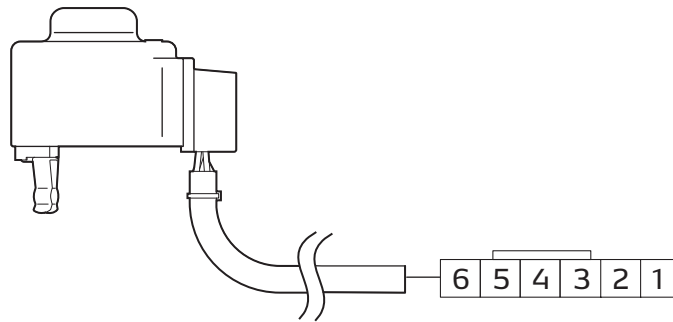

Connector Pin No.	6	5	4	3	2	1
Wire Color	X	White	Yellow	Orange	Blue	Red

## 4-Way Valve Controller Coil

Check the resistance across the connector pins of the 4-way valve controller coil.

If the coil resistance is not between 350 to 520 ohm at room temperature, replace the 4-way valve controller coil.

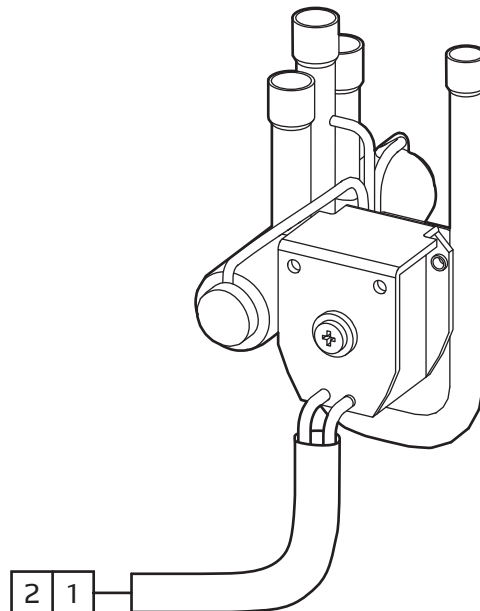

# REFRIGERATION SYSTEM

## Before Refrigerant Work

Prior to beginning work on refrigeration systems, safety checks are necessary to ensure that the risk of ignition is minimized. Please check the following items to ensure safe work.

### Work Area

- All maintenance staff and others working in the local area shall be instructed on the nature of work being carried out.
- Ensure adequate ventilation in the work area to minimize the concentration of refrigerant and promote a safe working environment.

### Check for Presence of Refrigerant

- Before and during refrigerant work, the area must be thoroughly checked using R32 refrigerant detector.
- Regularly calibrate and maintain the refrigerant detector according to manufacturer recommendations to ensure accuracy and reliability in detecting leaks.

### Presence of Fire Extinguisher

- Before conducting any hot work (like welding, cutting, or brazing) on the refrigerating equipment or associated parts, ensure that appropriate fire extinguishing equipment is readily available. Have a dry powder or CO2 fire extinguisher positioned adjacent to the charging area.

### No ignition Sources

- No person conducting work on the refrigerating system, especially work involving exposed pipe work, shall use any sources of ignition in a manner that may pose a risk of fire or explosion.
- Ensure that all possible ignition sources, including cigarette smoking, are kept sufficiently far away from the site of installation, repair, removal, or disposal where refrigerant can possibly be released into the surrounding space.
- Clearly display "No Smoking" signs in areas where refrigerant repair work is being conducted or where refrigerant may be present. This helps to reinforce the prohibition of smoking and reduce the risk of ignition.

### Ventilated Area

- Before breaking into the refrigerant system or conducting any hot work, ensure that the work area is either in the open or adequately ventilated. Adequate ventilation is essential to prevent the accumulation of potentially hazardous refrigerant.

### Detection of flammable refrigerants

- Do not use potential ignition sources, such as halide torches or detectors with open flames, to detect refrigerant leaks.
- When utilizing an electronic leak detector for R32 refrigerants, it is important to check the sensitivity and perform recalibration as needed. Calibration should be done in a location free of refrigerant.
- Use leak detectors that are not potential ignition sources and are suitable for R32 refrigerants.
- Set the equipment to detect the Lower Flammable Limit (LFL) percentage of R32 refrigerant and calibrate it accordingly (maximum 25%)
- Do not use leak detection fluids containing chlorine, which may react with the refrigerant and corrode copper pipe-work.

# Before Refrigerant Work

## Detection of flammable refrigerants

- If a leak is suspected, extinguish all open flames in the vicinity.
- In case of a leak requiring brazing, recover all refrigerant from the system.

## Labeling at time of disposal

- Units must be labeled to indicate that they have been decommissioned and emptied of flammable refrigerant.
- The label must be dated and signed.

## Recovery

- When recovering refrigerant from a system for servicing or decommissioning, ensure that all refrigerant is recovered safely.
- When transferring refrigerant into cylinders, only appropriate refrigerant recovery cylinders should be used. Ensure that an adequate number of cylinders are available to hold the entire system charge. All cylinders used are designated and labelled for the recovered refrigerant (special cylinders for refrigerant recovery). Cylinders should be complete with pressure relief valves and associated shut-off valves and in good working order. Before recovery takes place, empty recovery cylinders should be evacuated and cooled if possible.
- The recovery equipment must be in good working order with a set of instructions for the equipment at hand and must be suitable for the recovery of flammable refrigerants. If unsure, consult the manufacturer. In addition, a set of calibrated weighing scales shall be available and in good working order. Hoses shall be complete with leak-free disconnect couplings and in good condition.
- Recovered refrigerants must be disposed of in suitable recovery cylinders in accordance with local legislation and an associated waste transfer record must be prepared. Do not mix refrigerants within the recovery unit, especially within the cylinders.
- If compressors or compressor oils are to be removed, ensure that they have been evacuated to an acceptable level to make certain that flammable refrigerant does not remain within the lubricant. Do not heat the compressor body with an open flame or other source of ignition to speed up this process. When oil is drained from a system, it must be carried out safely.

 **WARNING**

When handling refrigerant, the following precautions should always be observed. Failure to do so may cause an explosion, fire, loss of vision, a lack of oxygen, burns, injury or unit malfunction.

- Refrigerant services must be performed only by A2L refrigerant certified professionals.
- Always wear proper eye protection and gloves while handling refrigerant.
- Avoid working near flammable materials including smoking.
- Work in a well-ventilated area only.
- Use a R32 refrigerant detector to check for refrigerant leaks before and during work.
- Provide a fire extinguisher near the workspace.
- Do not to mix different types of refrigerants when charging.
- Maintain the temperature of the refrigerant container below 104 °F (40 °C).
- Be careful not to allow refrigerant to contact eyes or skin.

If liquid refrigerant strikes eye or skin:

- Do not rub the eye or skin.
- Splash large quantities of cool water on the eye or skin.
- Apply clean petroleum jelly to the skin.
- Go immediately to a physician or hospital.

# Replacement of Refrigeration Cycle Parts



- Before replacing any refrigerant system parts, ensure that all refrigerant in the system has been recovered.

The parts of refrigeration system are connected with copper tubes by brazing each connection.

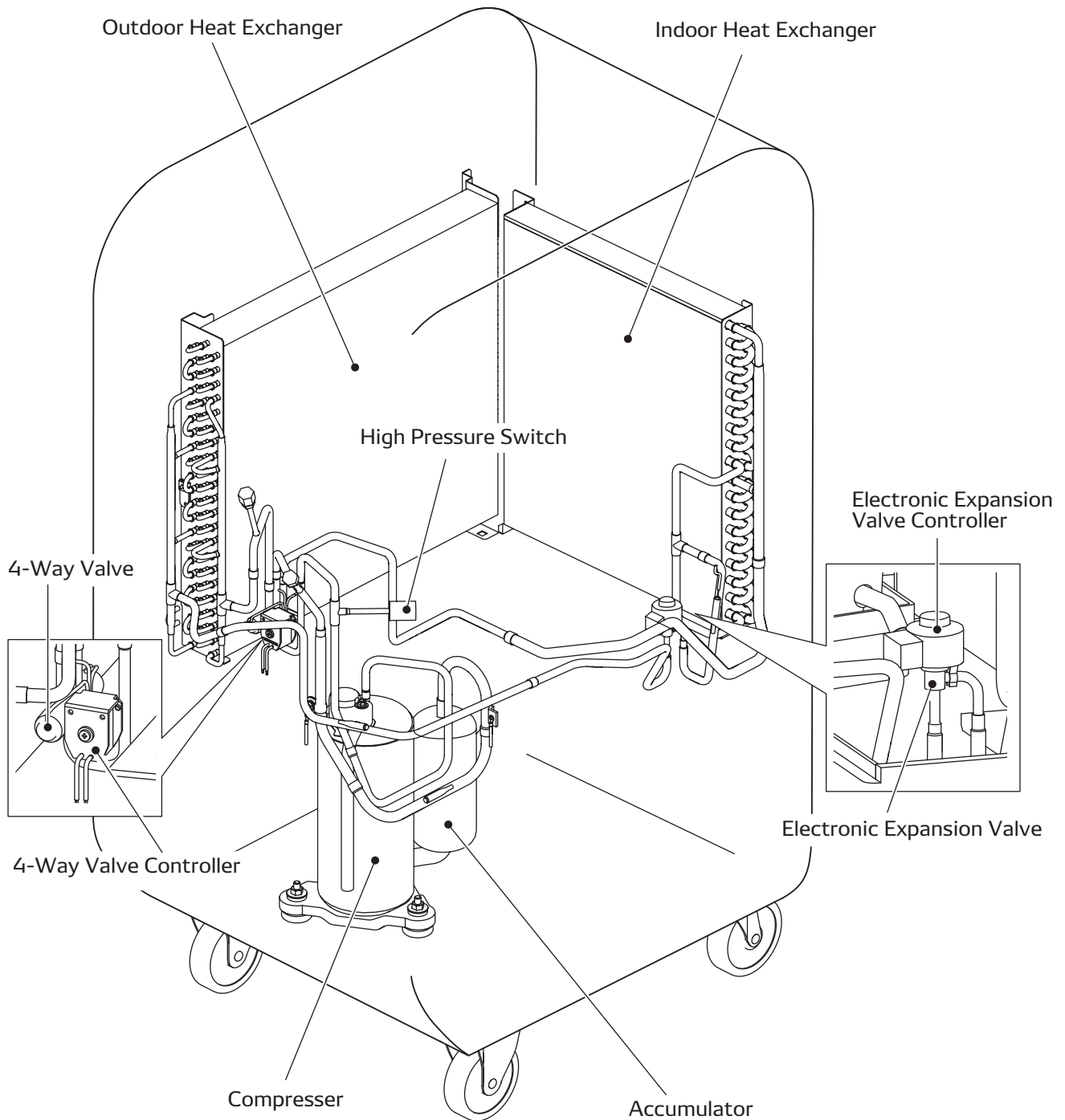

# Replacement of Refrigeration Cycle Parts

When recovering the refrigerant, use the service ports on the low pressure side (Service Port 1) and high pressure side (Service Port 2) as shown.

Note:

- The torque of service port nuts is  $13.7 \pm 2.2$  ft·lbf ( $18.6 \pm 3.0$  N·m).

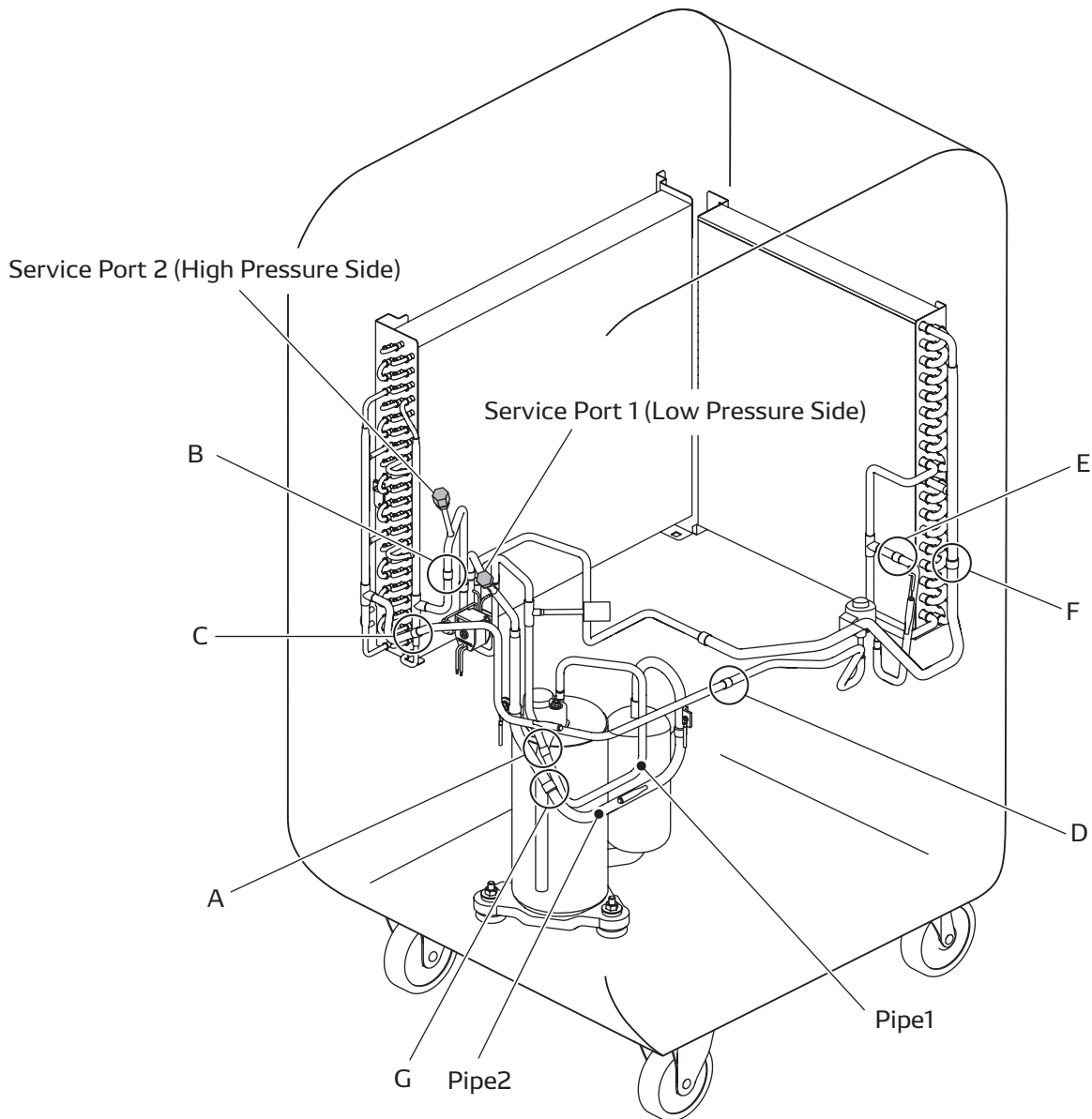

Part for Replacement	Disconnect At
Compressor	A, G
Indoor Heat Exchanger	E, F
Outdoor Heat Exchanger	B, C
Electronic Expansion Valve	D, E

Note:

- When replacing the compressor, replace pipe 1 and pipe 2 supplied with the compressor together.

# Replacement of Refrigeration Cycle Parts

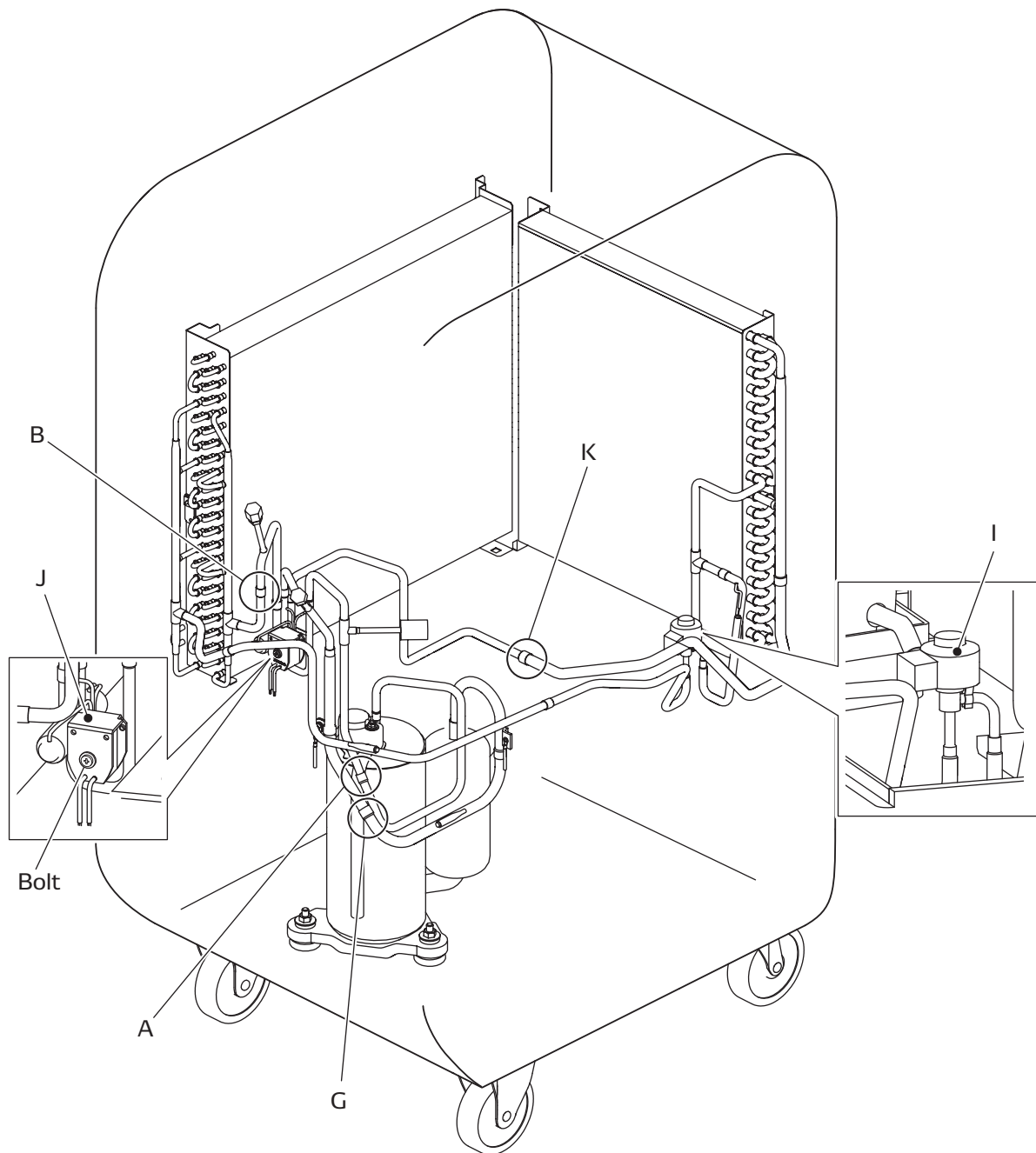

Part for Replacement	Disconnect At
Electronic Expansion Valve Controller	I (Lift and remove the expansion valve controller)
4-Way Valve Controller	J (Remove the bolt and remove the 4-way valve controller)
Pipe Assy with 4-Way Valve and High Pressure Switch	A, B, G, K

**Note:**

- When reinstalling the 4-way valve controller, fasten the bolt at the torque of  $2.0 \pm 0.18 \text{ ft}\cdot\text{lb}$  ( $2.7 \pm 0.25 \text{ N}\cdot\text{m}$ ).

## Brazing

If a problem with refrigerant system is found, replace or repair the relevant part. After replacing any part, all connections must be brazed.

### WARNING

To avoid burns, lack of oxygen or unit malfunction:

- **Brazing must be performed only by A2L refrigerant certified professionals.**
- **Before brazing, ensure that all refrigerant in the system has been recovered.**
- **When brazing, always wear eye protection and gloves.**
- **Work in a well-ventilated area only.**

### CAUTION

- **Do not use cleaners that contain chlorine. Chlorine cleaners may damage pipes.**
- **When brazing, wrap the high-pressure switch and the 4-way valve with a wet cloth and ensure their temperatures stay below 212°F (100°C).**

#### 1. Proper brazing techniques

It is desirable to use a slightly reduced flame. Oxyacetylene is commonly used since it is easy to judge and adjust the condition of the flame. Unlike gas welding, a secondary flame is used for brazing. It is necessary to preheat the base metal properly depending on the shape, size or thermal conductivity of the brazed fitting. The most important point in flame brazing is to bring the whole brazed fitting to a proper brazing temperature. Care should be taken not to cause overflow of brazing filler metal, oxidization of brazing filler metal, or deterioration due to the overheating of flux.

#### 2. Shape and clearance of brazed fitting

For the shape of the brazed fitting, it is necessary to maximize its adhesive area. The clearance of the brazed fitting must be minimized to facilitate the flow of the brazing metal filler by capillary action.

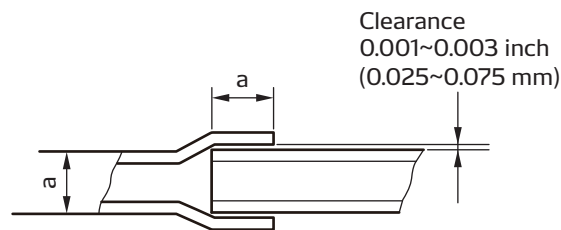

Clearance From Pipe Fitting and Tubing

# Brazing

## 3. Cleaning brazing filler metal and pipe

The surface of the metal combines with oxygen in the air and becomes covered with a very thin oxide film. Fats and oils often adhere to pipes due to handling. The metal and pipes must be cleaned before brazing. Fats and oils should be removed with a solvent such as trichlene. Rust and oxide should be removed with sand paper.

## 4. Use of dry nitrogen gas

The brazing flame oxidizes the inner surface of the pipe. To prevent this, introduce dry nitrogen gas from the service ports of the refrigeration system at a rate of 0.27 gal/min (1 L/min); adjust with the flow regulator. During any parts replacement, shield nearby parts with a steel plate to protect them from the flame.

Note:

- Take care not to allow dirt, water, oil to enter the pipe.

## 5. Vertical Joint

Heat the pipes so that heat is evenly transmitted throughout the fittings.

### a) Vertical Down Joint

When the fitting surface reaches the brazing temperature, add brazing metal and continue to heat, moving the burner downward as shown. The melted brazing metal flows toward higher temperature.

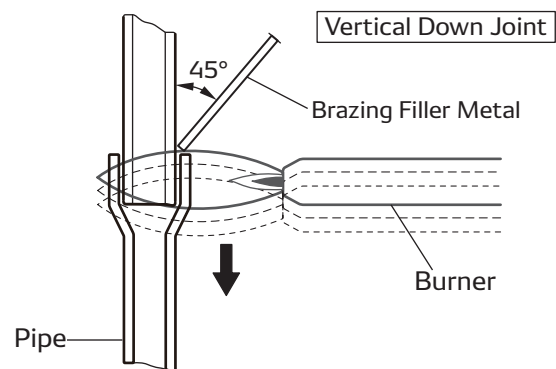

### b) Vertical Up Joint

Move the burner upward as shown. The brazing metal will flow upward through capillary action and through its nature of flowing toward higher temperature.

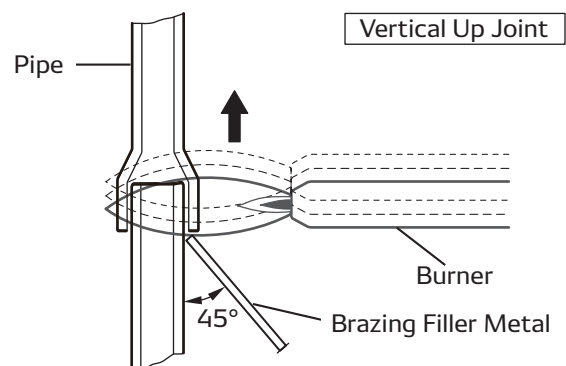

# Charging the System with R32 Refrigerant



- Use tools designed specifically for R32 refrigerant. Mixing different types of refrigerants can cause sludge, which can lead to compressor failure or clogging of the refrigerant system.
- Do not to mix different types of refrigerants when charging. Use only the specified refrigerant (R32). Failure to do so may result in fire, an explosion, or malfunction.
- Cylinders should be kept in an appropriate position according to the instructions.
- Ensure that the refrigerant system is earthed prior to charging the system with refrigerant.
- Extreme care must be taken not to overfill the refrigerant system.

Note:

- Prior to recharging the system, it shall be pressure-tested with the appropriate purging gas. The system shall be leak-tested on completion of charging but prior to commissioning. A follow up leak test shall be carried out prior to leaving the site.

Prepare the following items:

- Manifold gauge
- Vacuum pump
- R32 refrigerant cylinder (Use a max of 90% of the initial weight)
- Scale
- Safety goggles
- Heavy-duty work gloves

Step 1	Connect manifold gauge
Step 2	1) Evacuate the system <ul style="list-style-type: none"> <li>• 15 minutes or more</li> <li>• 30 inHg (100 kPa) or more of vacuum</li> </ul> 2) Stop evacuating the system <ul style="list-style-type: none"> <li>• Leave for 5 minutes</li> </ul> 3) Check the vacuum
Step 3	Connect to refrigerant source
Step 4	Test the system for leaks
Step 5	Charge the system with R32 refrigerant Amount of Refrigerant: 1.17 lb (0.53 kg) <ul style="list-style-type: none"> <li>• Label the system when charging is complete</li> </ul>
Step 6	Remove manifold gauge

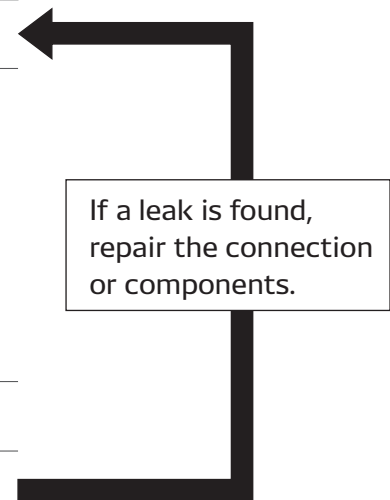

# REASSEMBLY

Reassemble the unit in the reverse order of removal. The following parts require special care in reassembling the unit.

## Wiring Diagram

Perform all wiring or rewiring as referenced in the wiring diagram.

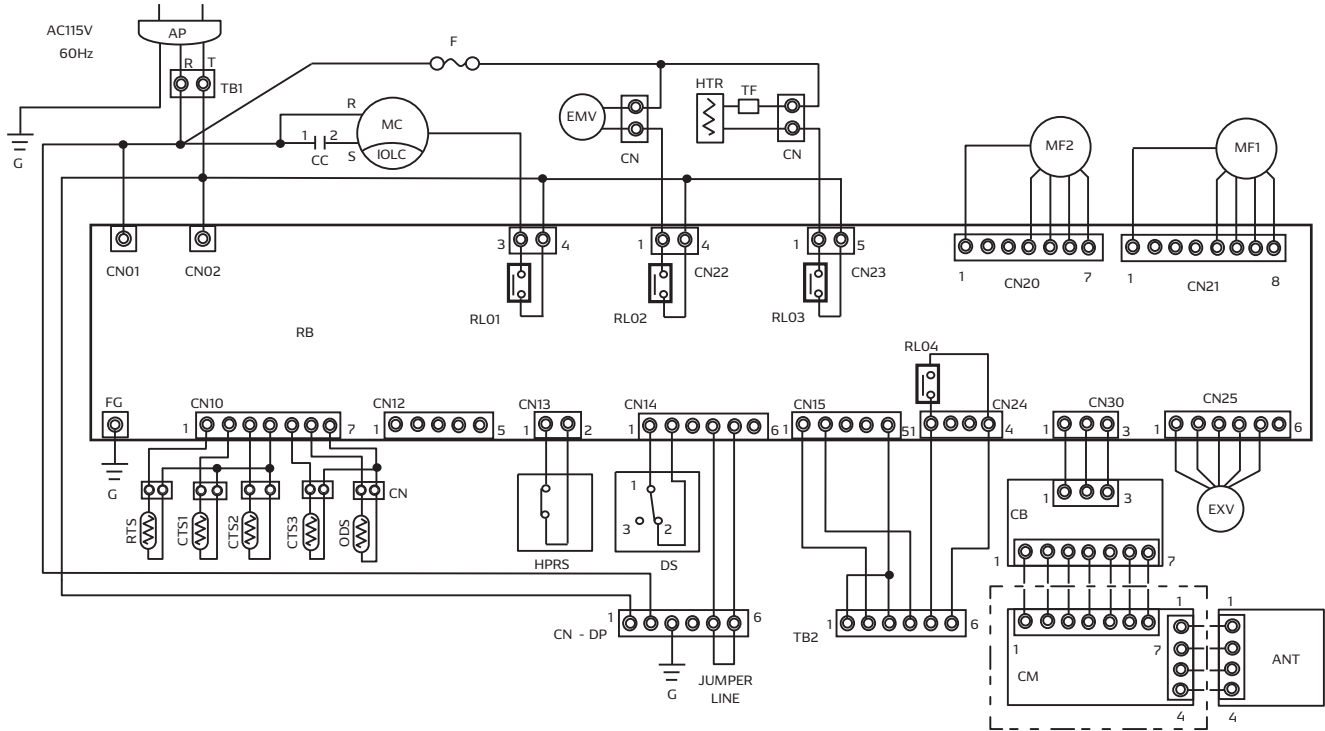

AP	Attachment Plug	RTS	Room Thermistor
TB1	Terminal Block	CTS1	Compressor Pipe Thermistor
TB2	Terminal Block	CTS2	Evaporator Pipe Thermistor
CB	Control Board	CTS3	Condenser Pipe Thermistor
RB	Relay Board	ODS	Outdoor Thermistor
MF1	Indoor Fan Motor	CN-DP	Connector for Drain Pump
MF2	Outdoor Fan Motor	CM	Communication Module (Optional)
MC	Compressor Motor	ANT	Antenna
CC	Capacitor for Compressor	EMV	4-Way Valve
IOLC	Inner Overload Relay for Compressor	HTR	Heater for Outdoor Drain Pan
HPRS	High Pressure Switch	EXV	Electronic Expansion Valve
DS	Full Drain Warning Switch	F	Fuse for EMV and HTR
G	Grounding	TF	Temperature Fuse for HTR

Note:

- Secure the wires with clamps to prevent contact with the edges of the parts of the unit. Re-secure the wires in the same position as prior to removal.

## Compressor Mounting

1. Install the three (3) cushions on the bolts.
2. Mount the compressor in the unit.
3. Insert the three (3) nuts and fasten at the torque of  $8.3 \pm 2.1$  ft·lbf ( $11.3 \pm 2.9$  N·m)

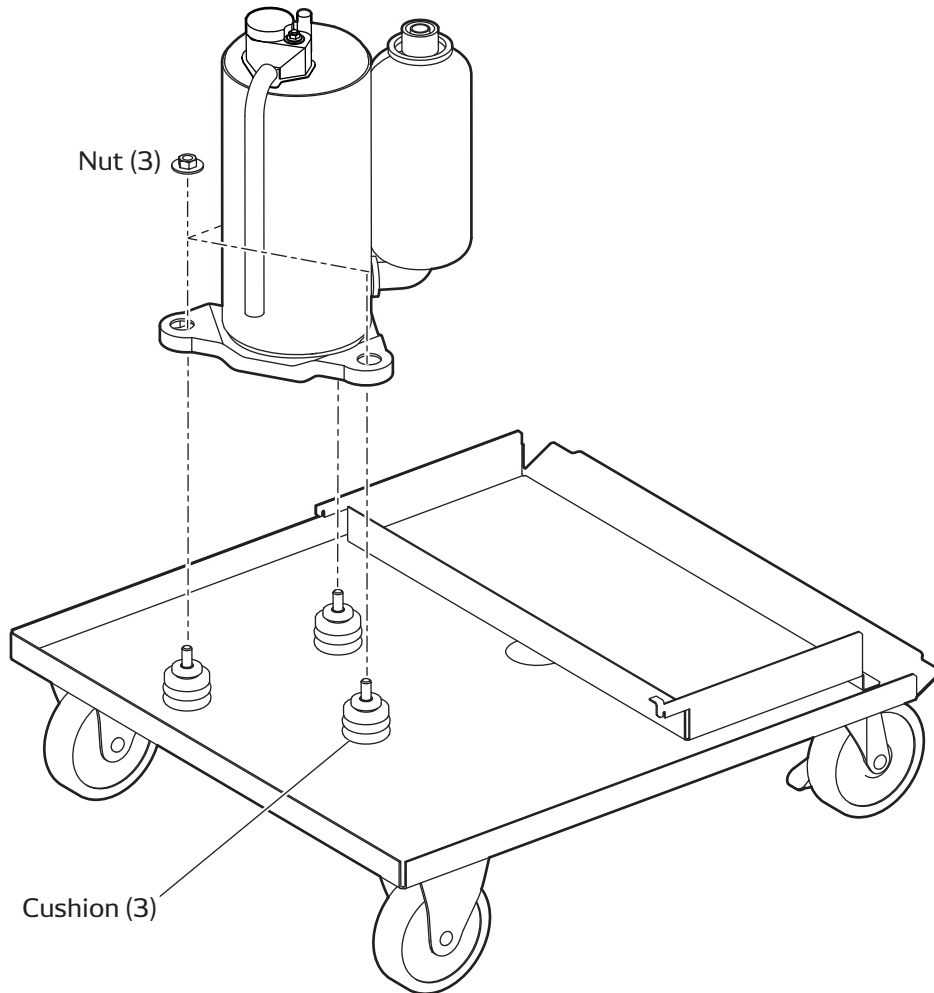

## Caster Maintenance

Lubricate bearings in caster as needed with standard bearing grease using the zerk fitting. Check if casters roll and swivel freely. Remove any build-up dirt or dust.

# DECOMMISSIONING



- **Decommissioning shall be done only by A2L refrigerant certified professionals.**
- **Refrigerant handling and disposal must be conducted according to Federal, State and Local regulations.**

Before carrying out this procedure, it is essential that the technician is completely familiar with the equipment and all its detail. All refrigerants must be recovered safely.

Prior to the task being carried out, an oil and refrigerant sample shall be taken in case analysis is required prior to re-use of recovered refrigerant. It is essential that electrical power is available before the task is commenced.

- a) Become familiar with the equipment and its operation.
- b) Isolate system electrically.
- c) Before attempting the procedure, ensure that:
  - mechanical handling equipment is available, if required, for handling refrigerant cylinders;
  - all personal protective equipment is available and being used correctly;
  - the recovery process is supervised at all times by a competent person;
  - recovery equipment and cylinders conform to the appropriate standards.
- d) Pump down refrigerant system, if possible.
- e) If a vacuum is not possible, make a manifold so that refrigerant can be removed from various parts of the system.
- f) Make sure that cylinder is situated on the scales before recovery takes place.
- g) Start the recovery machine and operate in accordance with instructions.
- h) Do not overfill cylinders (no more than 80 % volume liquid charge).
- i) Do not exceed the maximum working pressure of the cylinder, even temporarily.
- j) When the cylinders have been filled correctly and the process completed, make sure that the cylinders and the equipment are removed from site promptly and all isolation valves on the equipment are closed off.
- k) Recovered refrigerant shall not be charged into another refrigerant system unless it has been cleaned and checked.

# DATA PRIVACY DISCLOSURE

## Tracking of Machine Operation Data

This Unit is equipped with an embedded module that collects and transmits to us data on the Unit's operational performance ("Machine Operation Data"), including:

1. Hours of operation
2. Control Panel settings
3. Ambient Temperature
4. Error Codes
5. Geolocation

## How We Use the Data We Collect

The embedded module collects the Machine Operation Data in a format that is used for business analysis purposes, and does not identify the user. However, Machine Operation Data may become personal information about an identifiable individual when it is read together or combined with other personal information.

We use the Machine Data to:

- (i) Monitor the performance of the Unit.
- (ii) Analyze the performance of the Unit under actual environmental conditions.
- (iii) Analyze the performance of the Unit under actual user demand conditions.
- (iv) **Locate the Unit.**
- (v) Use aggregate data to enhance the performance, efficiency and usefulness of our products.
- (vi) Use aggregate data to modify, improve or develop new products, services and technologies.
- (vii) Comply with legal, regulatory or contractual requirements.

When you purchase or lease a Unit from us or one of our authorized distributors or resellers, we may obtain personally identifying information about you such as your name, address, phone number and e-mail address ("Personally Identifying Information"). We and our authorized distributors or resellers may use Machine

Operation Data together with Personally Identifying Information to:

- (i) Assist in trouble shooting and repair.
- (ii) Provide any safety updates or recall notices.
- (iii) Provide warranty service.
- (iv) Provide and improve customer support.
- (v) **Locate the Unit.**

The Machine Operation Data will be transmitted to us in the United States. While Machine Operation Data is in the United States it may be accessed by the courts, law enforcement and national security authorities pursuant to local U.S. laws.

## Sharing of Data

We shall use Machine Operation Data primarily for our own business purposes. We may also share your Unit's Machine Operation Data with the distributor, reseller or owner that sells or leases the Unit to you. This means that they will be able to determine the geolocation of the Unit.

We may disclose Machine Operation Data to a third party service provider in the United States for processing in order to analyze the performance of the Units and make improvements. The third party service provider is contractually bound to use Machine Operation Data solely for the purpose of providing services to us and not for their own purposes.

### Sharing of Data

We shall use Machine Operation Data primarily for our own business purposes. We may also share your Unit's Machine Operation Data with the distributor, reseller or owner that sells or leases the Unit to you. This means that they will be able to determine the geolocation of the Unit.

We may disclose Machine Operation Data to a third party service provider in the United States for processing in order to analyze the performance of the Units and make improvements. The third party service provider is contractually bound to use Machine Operation Data solely for the purpose of providing services to us and not for their own purposes.

### How Long We Keep Your Information

We may keep the information we collect for as long as necessary to provide products or services to you, to operate our business, to enable us to communicate with you, for our safety, research, evaluation of use, or troubleshooting purposes, or to satisfy our legal or contractual obligations. Where required, we will de-identify or dispose of the information we collect when we no longer need it for the uses described above.

### **CONSUMER RIGHT TO "OPT OUT" OF DATA SHARING**

**If you are a consumer and you do not want us to provide your Unit's Machine Operation Data, including the Unit's geolocation, or your Personally Identifying Information to your supplying distributor, reseller or owner, you may "Opt Out" by contacting us at 1-800-264-9573 or [www.movincool.com](http://www.movincool.com)**

**If you are a consumer and you do not want us to use a third party service provider to process your Unit's Machine Operation Data, you may "Opt Out" by contacting us at 1-800-264-9573 or [www.movincool.com](http://www.movincool.com)**

### **CONSENT TO OUR COLLECTION, USE AND DISCLOSURE OF MACHINE OPERATION DATA**

**By reading this notice and using this Unit, you consent to our collection, use and disclosure of Machine Operation Data. If you do not wish to give your consent, we will disable the Machine Operation Data tracking module upon request at 1-800-264-9573 or [www.movincool.com](http://www.movincool.com)**

### **CONSENT TO OUR COLLECTION, USE AND DISCLOSURE OF GEOLOCATION DATA**

**By reading this notice and using this Unit, you consent to our collection, use and disclosure of geolocation data. If you do not wish to give your consent, we will disable the Machine Operation Data tracking module upon request at 1-800-264-9573 or [www.movincool.com](http://www.movincool.com) The tracking of geolocation data is an integral function of the Machine Operation Data tracking module. Therefore, disabling the geolocation functionality will disable all other functionality of the Machine Operation Data tracking module. If the Machine Operation Data tracking module is disabled, we will not be able to provide you with any accompanying customer service enhancements.**

### **CONSUMER RIGHT TO WITHDRAW CONSENT**

**If you no longer wish to consent to our use, collection and disclosure of Machine Operation Data, you may contact us at 1-800-264-9573 or [www.movincool.com](http://www.movincool.com) and we will disable the Machine Operation Data tracking module.**

For further information about our privacy policy or our privacy management practices, please refer to [www.movincool.com](http://www.movincool.com)

***DENSO***

DENSO PRODUCTS AND SERVICES AMERICAS, INC.

Long Beach, CA 90810

[www.movincool.com](http://www.movincool.com)