

# Office Pro 12,18 and 24 Air Plenum Installation

CAREFULLY READ INSTRUCTIONS FOR CORRECT INSTALLATION AND USAGE.

**1** Unplug the unit from the receptacle.

**2** Move the unit to an open area with enough room for the installation process.

**Note:** Before installing the air plenum onto the Office Pro 18, an air plenum bracket must be installed. The Office Pro 18 does not require a bracket.

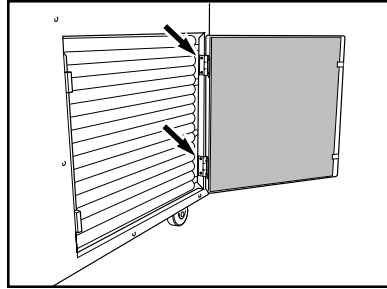

**3** Remove the four (4) screws that attach the filter door hinge to the condenser side panel. Remove the door with hinges from the unit (save the screws and door for future use).

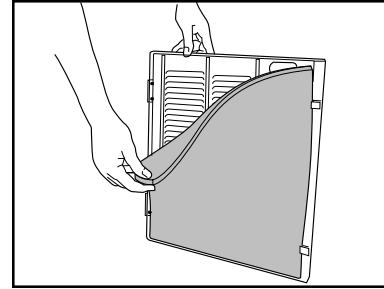

**4** Remove the filter from the filter door and set aside.

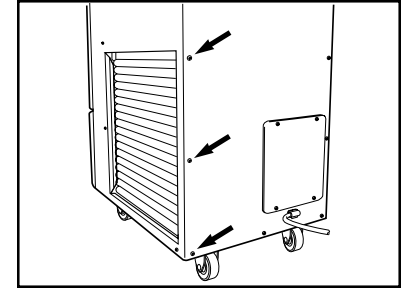

**5** Temporarily remove the left lower three (3) screws from the rear panel of the unit.

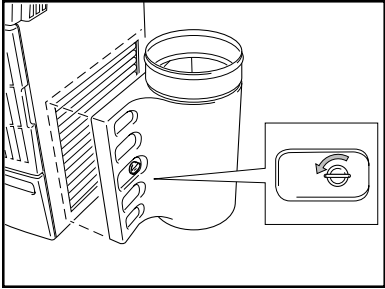

**6** Turn the latch of the Air Plenum counterclockwise until it stops. Place the Air Plenum over the condenser opening and align the hinge/bracket assembly mounting holes with the respective screw holes on the back of the unit.

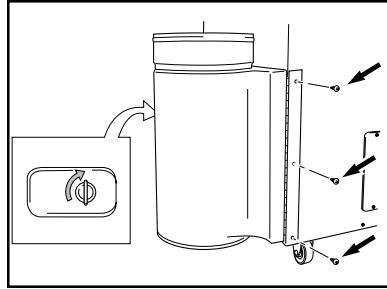

**7** For ease of installation, turn the latch to the full clockwise position. (This will hold the front part of the Plenum onto the unit). Attach the hinge/bracket of the Air Plenum to the rear of the unit using the original three (3) screws that were temporarily removed in step 5.

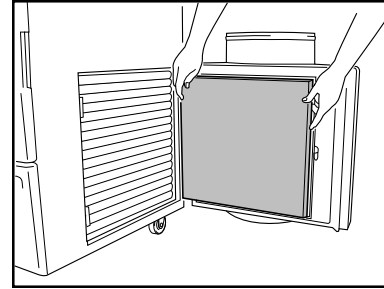

**8** Open the Air Plenum by turning latch counterclockwise and install the air filter element from the condenser door onto the Air Plenum as indicated.

**9** Close and secure the Air Plenum to the unit.

The unit is now ready for use.

Air Plenum Kit Part Number:

OP12, OP18: LAY84270-008A

OP24: LAY84270-0050



**MOVINCOOL**  
THE PORTABLE SPOT COOLING SOLUTION

© 2003 DENSO SALES CALIFORNIA, INC.  
DENSO P/N: LA990009-1346  
[www.movincool.com](http://www.movincool.com)

---

**Subject: Condenser Air Plenum Bracket Kit Instruction Sheet**

---

**Note:** *The condenser air plenum bracket kit must be used if installing a condenser air plenum on an Office Pro 18. The condenser air plenum bracket can be discarded if installing a condenser air plenum on an Office Pro 12.*

**⚠Caution:** *Unit should be turned off before bracket is installed.*

**Installation Procedures:**

1. Open the condenser door located on the right side of the unit.
  2. Locate the two (2) magnetic door holders.
  3. Remove the lower screw on the top magnetic door holder.
  4. Remove the upper screw on the bottom magnetic door holder.
- 
5. Place the plenum bracket between the two (2) magnetic door holders.
  6. Slide the two tabs behind the condenser door frame.
  7. Align the bracket screw holes as shown.
  8. Reinstall the two (2) screws into their original locations with the bracket in place.
  9. Install the Air Plenum Kit (Part No. LAY84270-008A).

**Ceiling Tile Kit Inventory:**

- One (1) Plenum bracket
- One (1) Instruction sheet

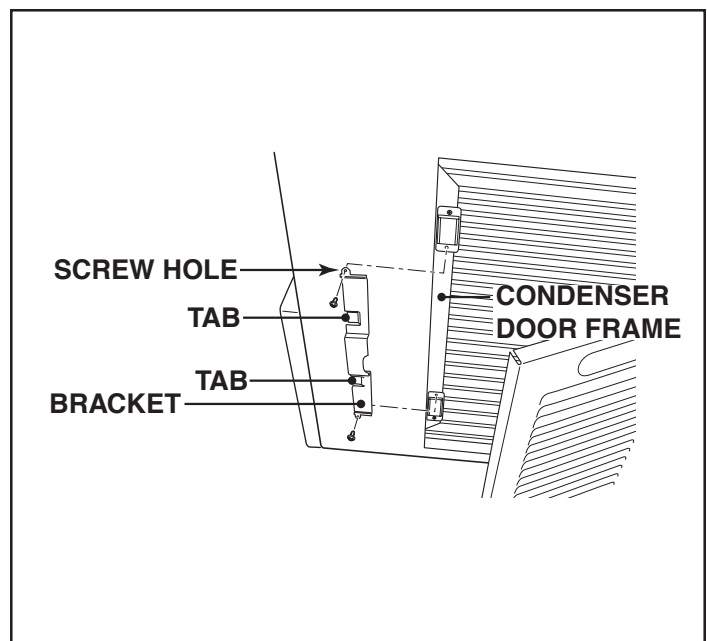
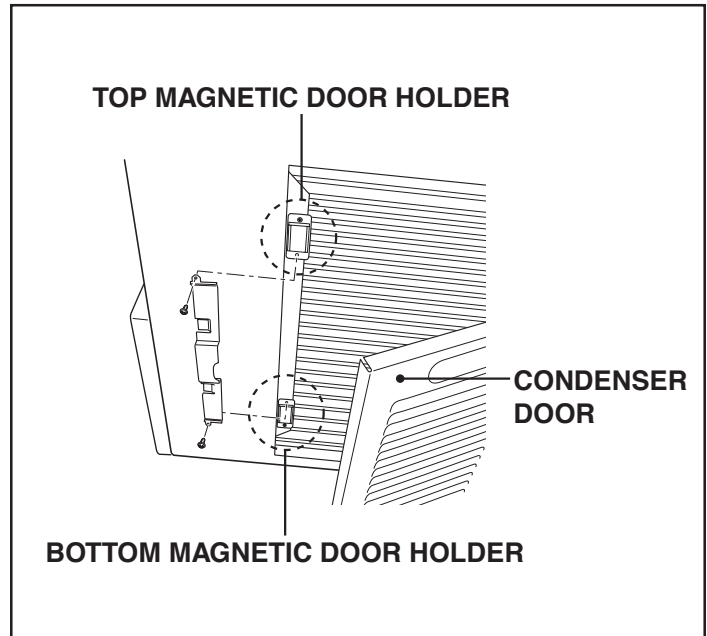

---

If you have any questions concerning the above information, please call MovinCool at (800) 264-9573.

3900 Via Oro Avenue, Long Beach, California 90810

# Bracket for OP24 Air Plenum

- 1** Before installing the bracket, remove the condenser side panel to prevent any damage to the condenser fins/tubes. Remove four (4) screws from the upper side panel.

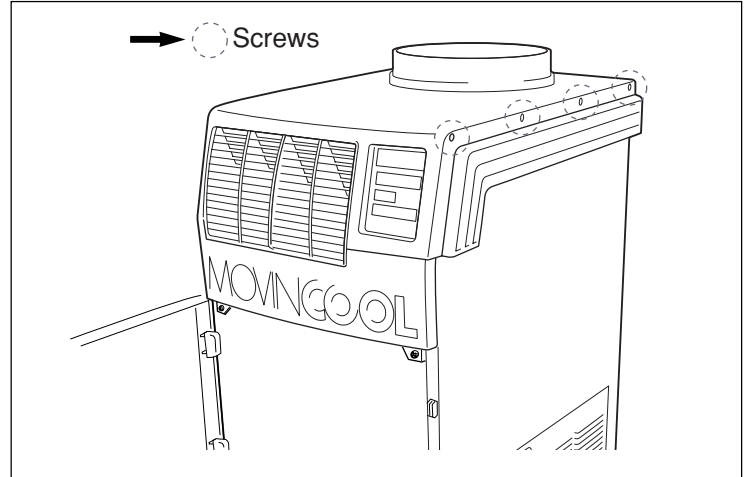

- 2** Remove four (4) screws from the back panel.

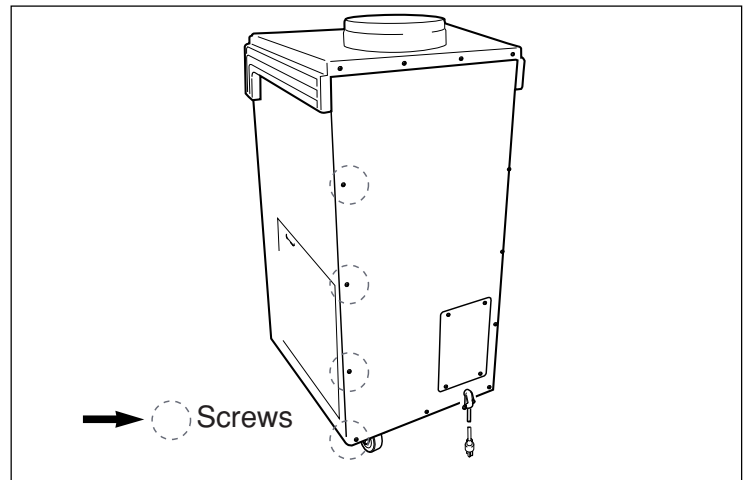

- 3** Remove nine (9) screws from the condenser side panel.

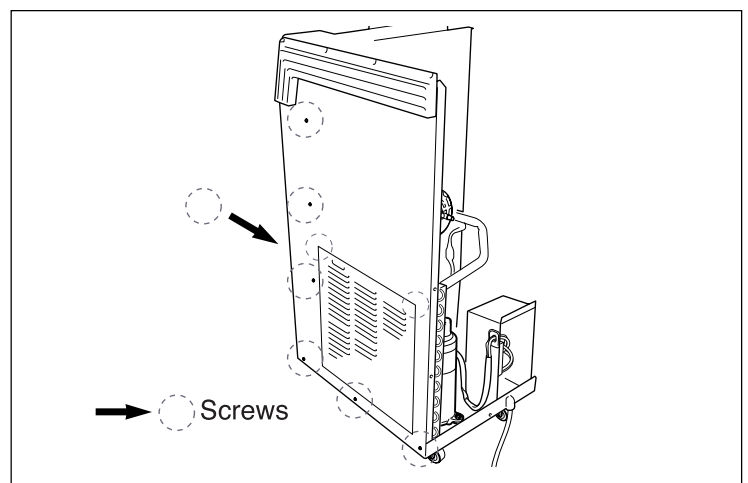

**4** Position Bracket as shown in the adjacent figure. The distance from the bottom of the condenser opening to the bottom of the bracket should be  $125 \pm 2\text{mm}$  ( $4 \frac{15}{16}''$ ).

**5** Using the self tapping screws and washers provided, carefully secure the bracket to the condenser side panel using a torque limited cordless screwdriver. Torque to  $2.04 \text{ N}\cdot\text{m}$  ( $18\text{ lbf}\cdot\text{in}$ ). Do not overtighten.

**6** Reinstall the panels previously removed. Be careful not to damage condenser fins upon reassembly.

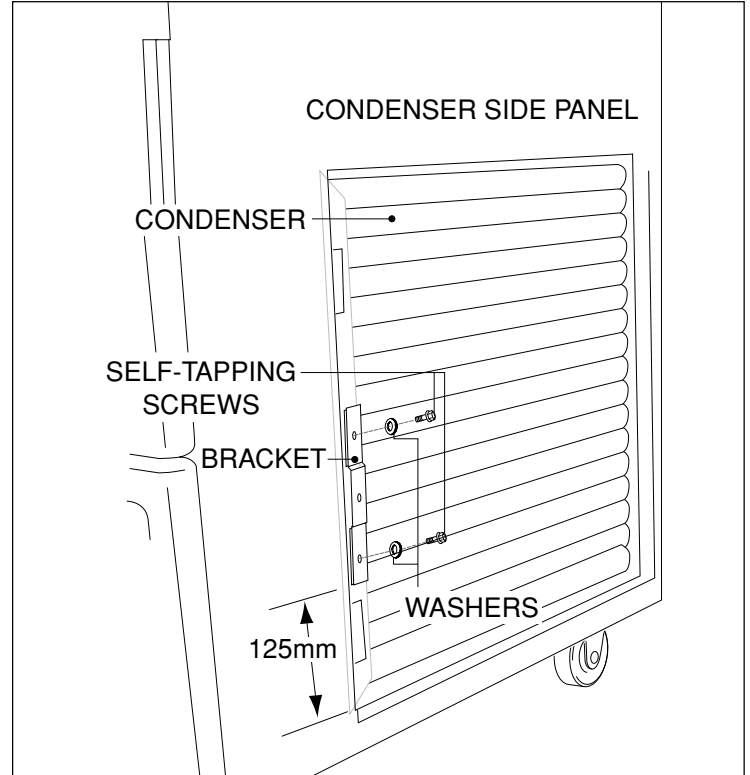

# Instalación del 'Office Pro 18 y 24 Air Plenum'

PARA INSTALAR Y UTILIZAR CORRECTAMENTE EL DISPOSITIVO, LEA CUIDADOSAMENTE LAS INSTRUCCIONES

**1** Desenchufe la unidad del receptáculo.

**2** Traslade la unidad a un espacio abierto lo suficientemente amplio para permitir el proceso de instalación.

**Nota:** Antes de la instalación del air plenum en el modelo Office Pro 18 un sujetador apropiado debe ser instalado. El modelo Office Pro 18 no requiere sujetador.

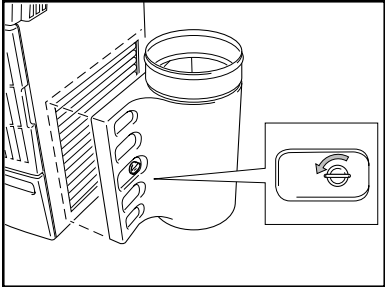

**6** Gire el pestillo del contenedor 'Air Plenum', en sentido antihorario, hasta que se pare. Coloque el 'Air Plenum' sobre la abertura del condensador y alinee los orificios de montaje del conjunto de bisagra/ménsula con los correspondientes orificios para los tornillos de la parte trasera de la unidad.

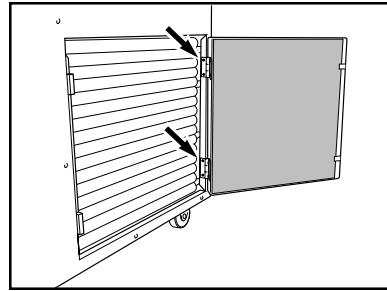

**3** Saque los cuatro (4) tornillos que sujetan las bisagras de la puerta de filtro al panel lateral del condensador. Retire la puerta, con las bisagras, de la unidad (guarde los tornillos y la puerta para uso futuro).

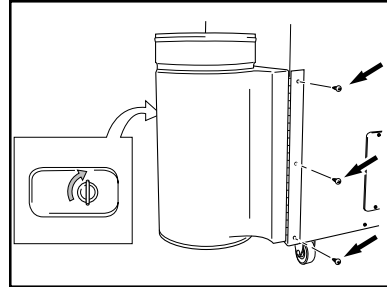

**7** Para facilitar la instalación, gire completamente el pestillo en sentido horario (de esta forma se sujetará la parte delantera del 'Plenum' a la unidad). Instale la bisagra/ménsula del 'Air Plenum' en la parte trasera de la unidad, haciendo uso de los tres (3) tornillos que previamente habían sido retirados en el paso 5.

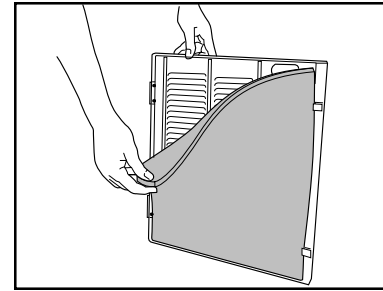

**4** Retire el filtro de la puerta de filtro y déjelo aparte.

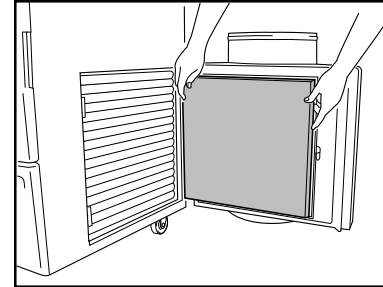

**8** Abra el 'Air Plenum' (girando el pestillo en sentido antihorario) e instale el elemento del filtro de aire (procedente de la puerta del condensador) en el 'Air Plenum' (tal como se indica).

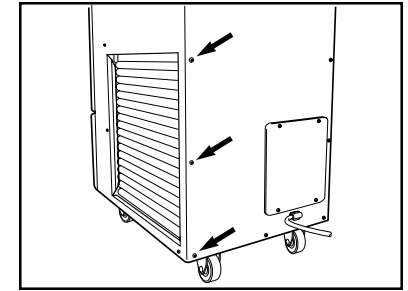

**5** Retire temporalmente los tres (3) tornillos de la parte inferior izquierda del panel trasero de la unidad.

**9** Cierre y afiance el 'Air Plenum' a la unidad.

La unidad ya está lista para usar.

Numero de Parte para 'Air Plenum Kit':

OP12, OP18: LAY84270-008A

OP24: LAY84270-0050



**MOVINCOOL**  
LA SOLUCIÓN IDEAL EN ACONDICIONADORES PORTÁTILES

© 2003 DENSO SALES CALIFORNIA, INC.  
DENSO P/N: LA990009-1346  
www.movincool.com