

OPERATION MANUAL

CLASSIC 40 and CLASSIC 60

SERIAL NUMBER FROM APRIL 2009 (0409) TO JUNE 2011 (0611)



**READ THIS MANUAL CAREFULLY FOR INSTRUCTIONS ON CORRECT
INSTALLATION AND USAGE, AND READ ALL SAFEGUARDS**

SECCIÓN EN ESPAÑOL
SECTION EN FRANÇAIS
AVAILABLE AT WWW.MOVINCOOL.COM



MOVINCOOL®
THE #1 SPOT COOLING SOLUTION

© 2010 DENSO SALES CALIFORNIA, INC.

All rights reserved. This book may not be reproduced or copied, in whole or in part, without the written permission of the publisher.

DENSO SALES CALIFORNIA, INC. reserves the right to make changes without prior notice. MovinCool is a registered trademark of DENSO Corporation.

OPERATION MANUAL

CLASSIC 40 and CLASSIC 60

MOVINCOOL®
THE #1 SPOT COOLING SOLUTION

Table of Contents

FOREWORD	5
Definition of Terms	5
GENERAL WARNINGS & CAUTIONS	5
INVENTORY & ASSEMBLY	6
Inventory	6
Assembly of Exhaust Duct (For Classic 60 ONLY)	8
INSTALLATION	9
Unit Overview.....	9
Exterior Dimensions.....	10
Choosing an Installation Site	12
Plugging in the Unit (For Classic 40 ONLY).....	13
Power Supply and Field Wiring Connection (For Classic 60 ONLY)	14
Optional Accessories and Set Up Configuration	16
Wall Thermostat Connection (Millivolt System ONLY: Option)	24
Warning Signal Connection (Output Signal Terminal L+ and L-).....	27
Fire Alarm Control Panel Connection (Input Signal Terminal E+ and E-)	29
OPERATION	31
Features.....	31
Control Panel	32
Operating Modes	34
Operating in COOL Mode.....	35
Operating in FAN ONLY Mode.....	35
Changing from FAN ONLY Mode to COOL Mode	35
Self-Diagnostic Codes	36
DAILY INSPECTION & MAINTENANCE	37
Clean the Air Filters.....	37
Filter Removal Method	37
Filter Element Cleaning Method.....	37
In-Season/Off-Season Inspection & Maintenance	38
TROUBLESHOOTING	40
Installation Check Sheet	42
TECHNICAL SPECIFICATIONS	43

FOREWORD

Congratulations on purchasing the MovinCool spot cooling system. This manual explains how to assemble, install and operate the MovinCool Classic 40, and Classic 60 spot cooling system. Please read this operation manual thoroughly to familiarize yourself with the features of the unit and to ensure years of reliable operation.

You may also find it useful to keep this operation manual on hand for reference. Components and/or procedures are subject to change without prior notice.

Definition of Terms



WARNING: Describes precautions that should be observed in order to prevent injury to the user during installation or unit operation.



CAUTION: Describes precautions that should be observed in order to prevent damage to the unit or its components, which may occur during installation or unit operation if sufficient care is not taken.

Note: Provides additional information that facilitates installation or unit operation.

GENERAL WARNINGS & CAUTIONS

1. All electrical work, if necessary, should only be performed by qualified electrical personnel. Repair to electrical components by non-certified technicians may result in personal injury and/or damage to the unit. All electrical components replaced must be genuine MovinCool parts, purchased from an authorized reseller.
2. Installation should be conducted by a qualified technician only. DENSO and DENSO affiliates are not responsible for injuries and/or damages caused by improper installation.
3. Never fold or place heavy objects on the power cord. This could result in damage to the power cord causing electrical shock or fire.
4. Do not place water or any other liquid on the unit. This can cause damage to the unit and increase the risk of electrical shock.
5. Do not sit or stand on the unit.
6. Do not place hands or any object in the cool air outlet or exhaust duct. Touching the fan, which is rotating at a high speed, is very hazardous.

INVENTORY & ASSEMBLY

Inventory

Classic 40

After unpacking your MovinCool unit, please check to make sure you have the following items:

1. **Classic 40 MovinCool Unit (1)**
2. **Clip (2)**
3. **Grommet (2)**
4. **Operation Manual/Product Registration (1)**

Note: If any of these items were not included in the box or appear damaged, please contact your MovinCool reseller for replacement.

CLASSIC 40 UNIT

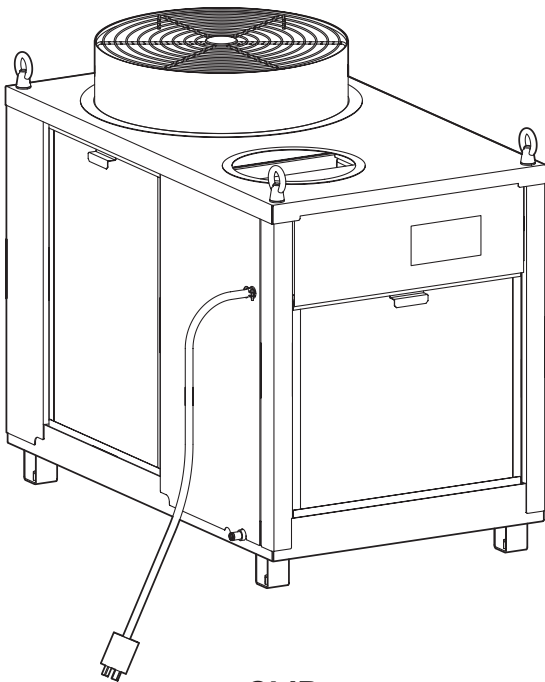

**OPERATION MANUAL /
PRODUCT REGISTRATION**



CLIP

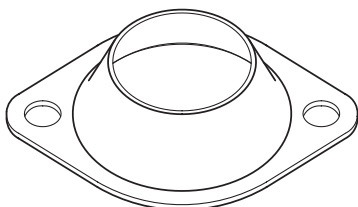

GROMMET

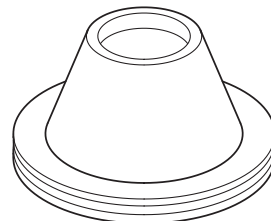

INVENTORY & ASSEMBLY (cont.)

Inventory (cont.)

Classic 60

After unpacking your MovinCool unit, please check to make sure you have the following items:

1. Classic 60 MovinCool Unit (1)
2. Exhaust Duct for Condenser (1)
3. Clip (2)
4. Grommet (2)
5. Operation Manual/Product Registration (1)

Note: Power cord is not supplied with Classic 60.

If any of these items were not included in the box or appear damaged, please contact your MovinCool reseller for replacement.

CLASSIC 60 UNIT

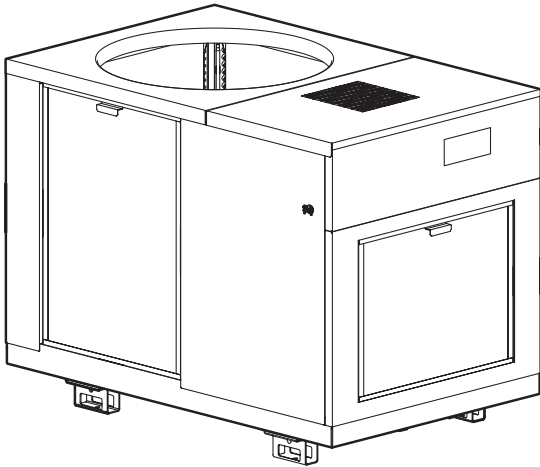

**OPERATION MANUAL /
PRODUCT REGISTRATION**



EXHAUST DUCT FOR CONDENSER

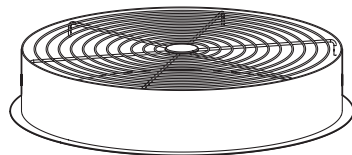

CLIP

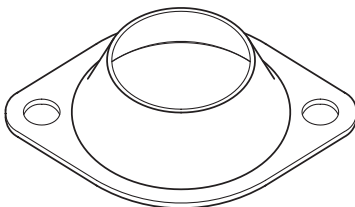

GROMMET

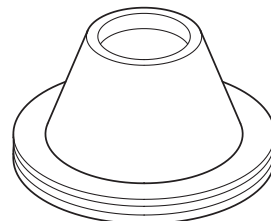

INVENTORY & ASSEMBLY (cont.)

Assembly of Exhaust Duct (For Classic 60 ONLY)

1. Remove the exhaust duct from the package.

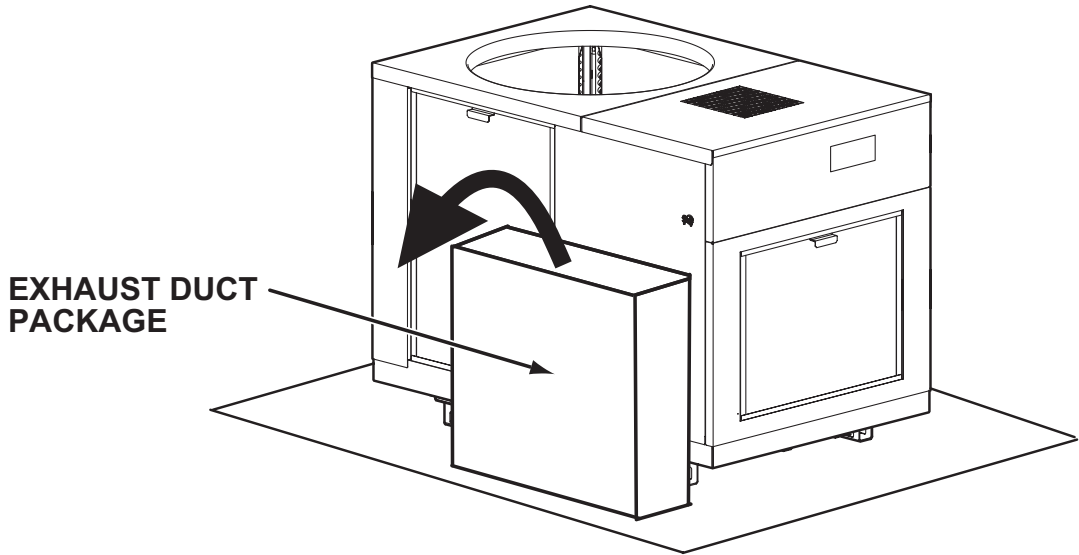

2. Install the exhaust duct to the unit, using eight (8) bolts provided in the exhaust duct package.

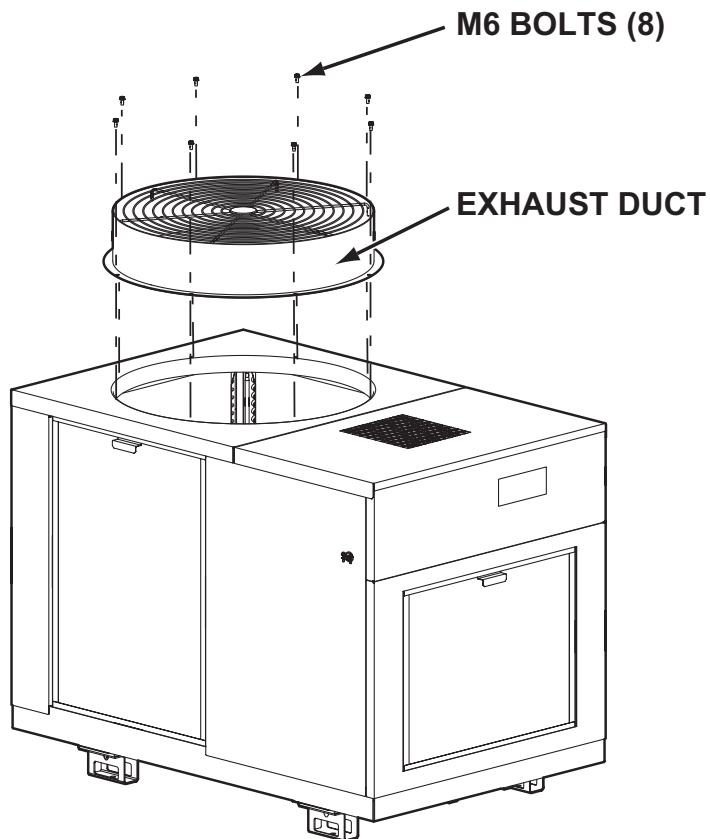

INSTALLATION

Unit Overview

Classic 40

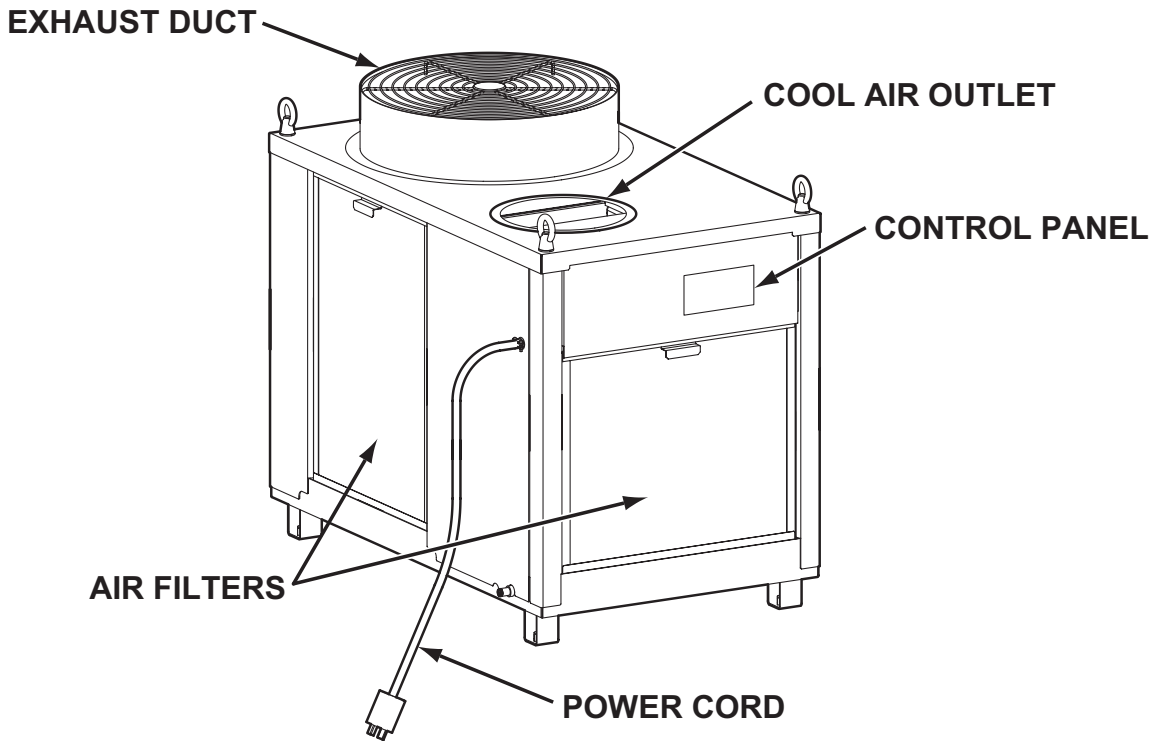

Classic 60

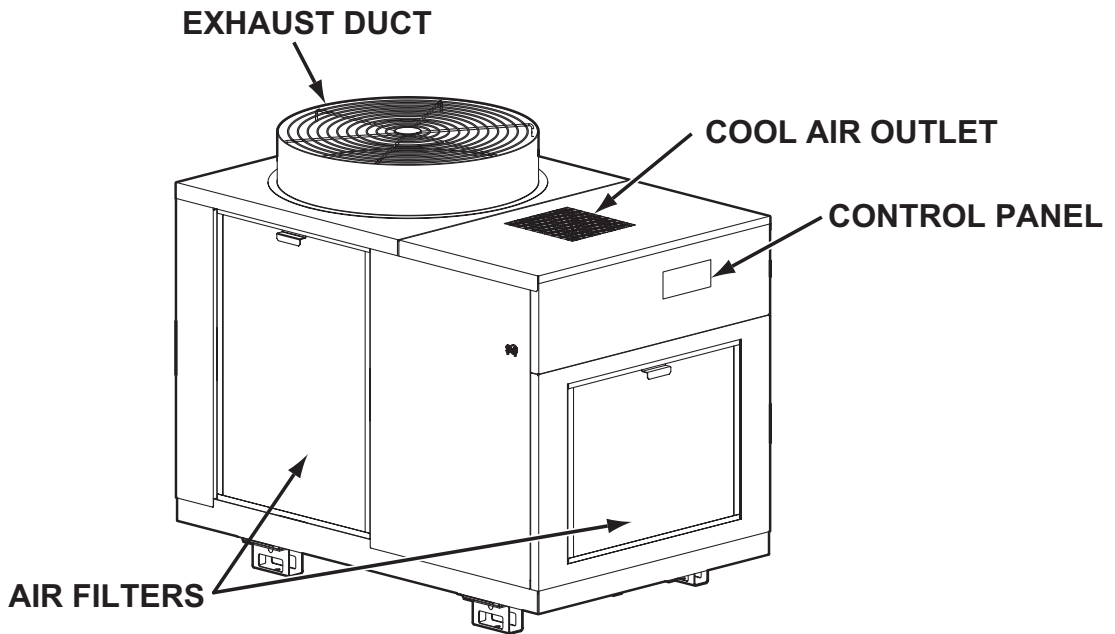

INSTALLATION (cont.)

Exterior Dimensions

Classic 40

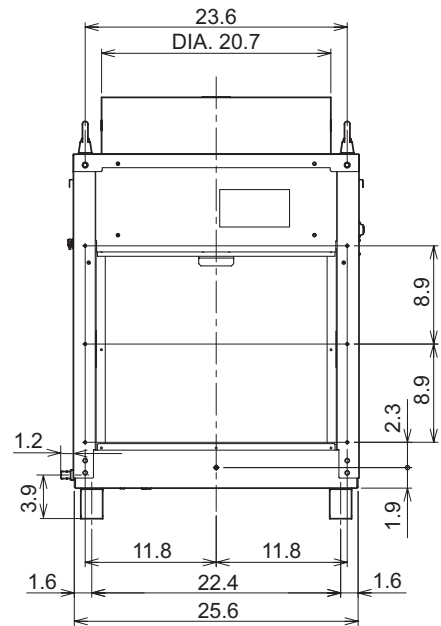
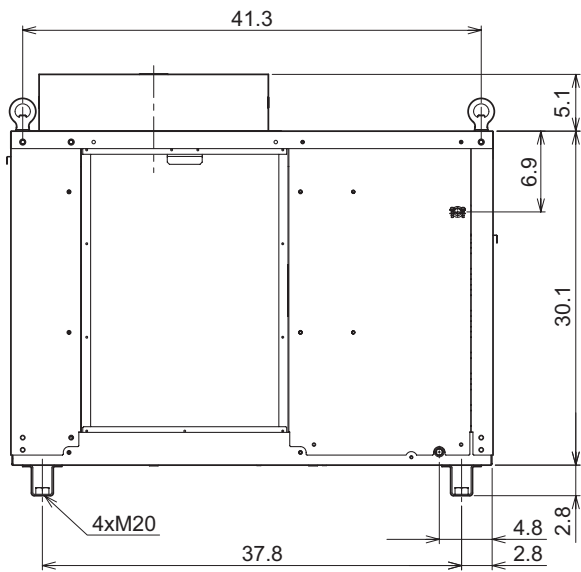
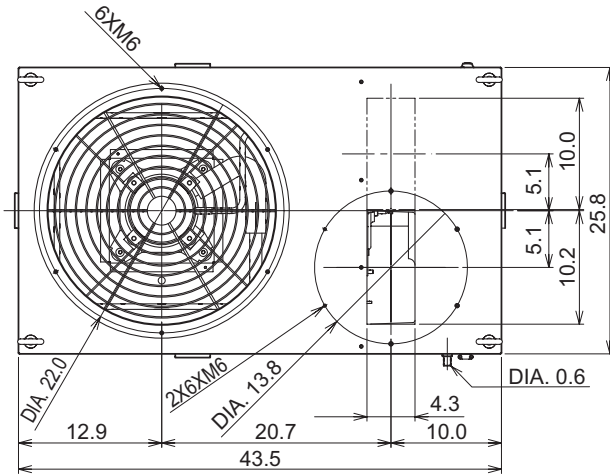

Unit: inch

INSTALLATION (cont.)

Exterior Dimensions (cont.)

Classic 60

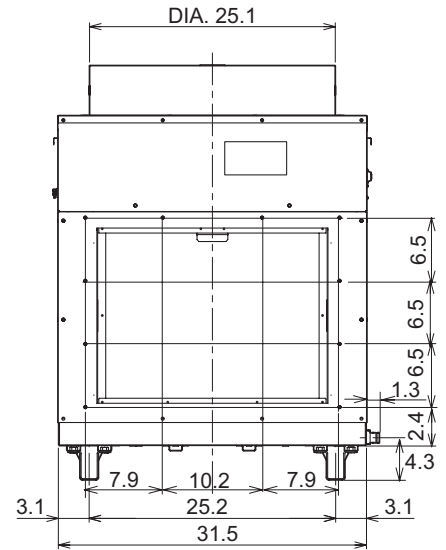
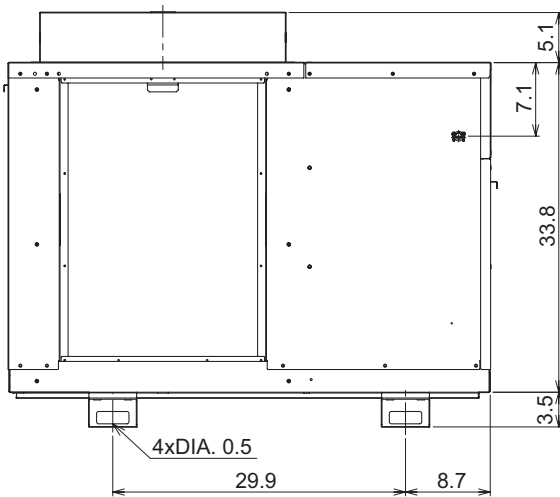
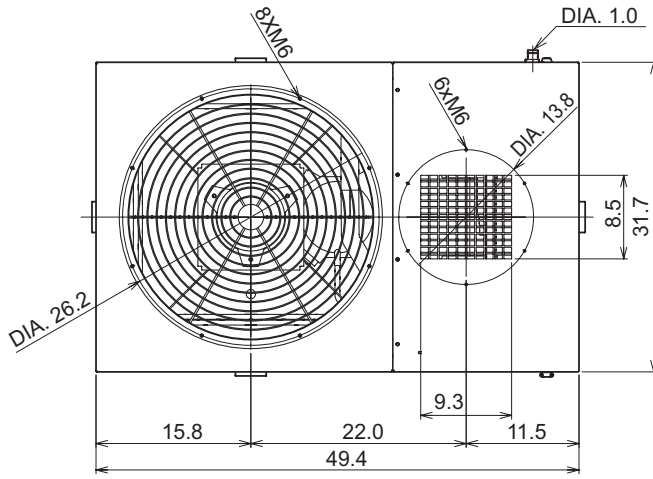

Unit: inch

INSTALLATION (cont.)

Choosing an Installation Site



CAUTION: Following are some precautions to consider before choosing your installation site. Please review carefully as improper installation may result in personal injury or damage to the unit.

1. Do not use the unit in areas where leakage of flammable gas may occur.
2. Do not use the unit in an environment which contains excessive amounts of corrosive gas or vapor.
3. Do not place obstacles near the air inlet and outlet. Insufficient air flow may activate the protection device or result in insufficient cooling.
4. Install the unit level with no more than 1.5 ° incline.
5. Install the unit in areas that can with-stand the weight of the unit. The Classic 40 unit weighs approximately 344 lb (156 kg), and the Classic 60 unit weighs approximately 474 lb (215 kg).
6. Allow 18.0 in (457 mm) of unobstructed airflow for both the air inlets and outlets.
7. Do not use the unit at condition below 75 °F (24 °C) or above 113 °F (45 °C) 50 %RH.
8. Provide proper ventilation if the unit is installed in an enclosed area.

INSTALLATION (cont.)

Plugging in the Unit (For Classic 40 ONLY)

1. Check the prongs and surface of the power cord plug for dust/dirt. If dust and/or dirt are present, wipe off with a clean, dry cloth.
2. Check the power cord, plug and prongs for damage or excess play. If any damage or excess play is found, contact your MovinCool reseller or a qualified technician for repair.



WARNING:

1. **If the power cord or plug is damaged, repair should only be performed by qualified electrical personnel.**
2. **Do not connect/disconnect the power cord or attempt to operate buttons with wet hands. This could result in electrical shock.**
3. **The power supply should be a dedicated single outlet circuit with a UL approved short-circuit and ground fault protective breaker with a recommended fuse size of 25 A (25 A maximum).**
4. **Because of potential safety hazards under a certain condition, we strongly recommend against the use of an extension cord. However, if you still elect to use an extension cord, it is absolutely necessary that it is a UL listed, 4-wire grounding type appliance extension cord, having a 4-blade grounding plug and a 4-slot receptacle that plugs into the appliance. The marked rating of the extension cord should be 220 V, 25 A or equivalent.**



CAUTION: The AC outlet should be rated minimum 25 A at 220 VAC, 3 phase, 60 Hz. Do not share the outlet with any other instrument or equipment.

Note:

1. *Make sure the AC outlet is free of dirt, dust, oil, water, or any other foreign matter.*
2. *The Classic 40 is equipped with an approved NEMA plug configuration (L15-30). The appropriate outlet must be used for this plug type.*

INSTALLATION (cont.)

Power Supply and Field Wiring Connection (For Classic 60 ONLY)

Power Supply

- AC 460 V \pm 10 %, 3 phase and 60 Hz. Do not connect the unit to any other power supply.
- The power supply should be a dedicated single outlet circuit with a UL approved short-circuit and ground fault protective breaker with a recommended fuse size of 20 A (20 A maximum).
- Securely tighten each terminal.

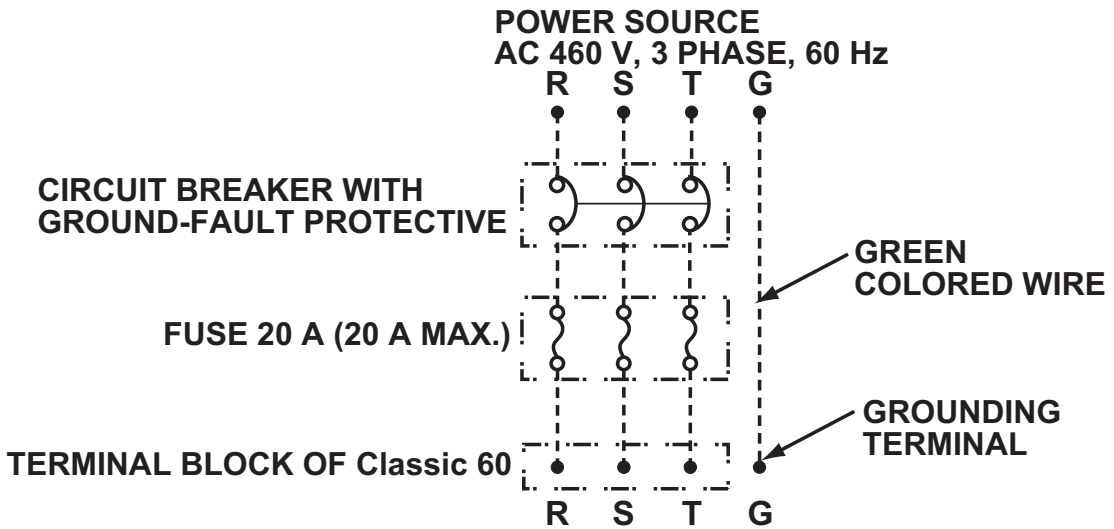

CAUTION: Use a specified 20 A fuse. Do not use wiring, copper wire or soldering instead of the fuse. The use of non-specified fuses can cause machine failure or fire.

INSTALLATION (cont.)

Power Supply and Field Wiring Connection (For Classic 60 ONLY) (cont.)

Power Supply Wires

- Use at least 12 AWG for the power wires.
Cord type (4 wires): SO, SOT, SOOW or equivalent
Voltage rating: 600 V Minimum
Heat resistance: 140 °F (60 °C) or above
- Prepare three power wires for motive power and one wire (green) for grounding.
- Make sure to use conduit tubing when installing power wires.

Connection to Classic 60

1. Remove three (3) screws from the upper panel on the control panel side and open the upper panel.
2. Pass the power wire through the conduit hole in the left side panel.
3. Attach the conduit tubing to the conduit hole.
Trade size of conduit is 1/2 inch.
4. Connect the power wires to the R, S, T and Grounding terminal.
Tightening torque: 0.96 ft•lbf (1.3 N•m)

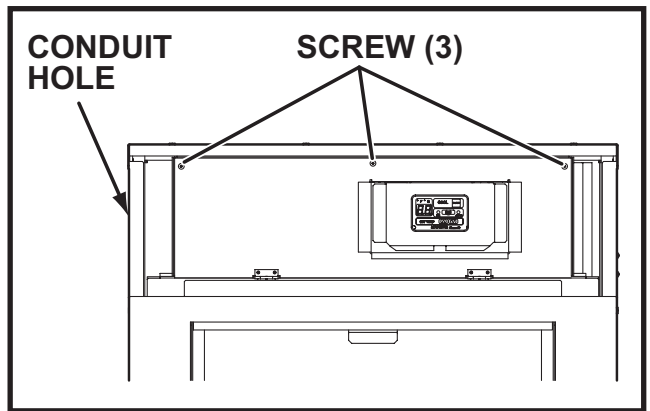

Note: Classic 40 and Classic 60 are equipped with phase protectors.

1. *The phase sequence is in order of R, S, and T. If the phase sequence is reversed, the unit does not operate.
At this condition, exchange two of the power wires for R, S and T terminals.*
2. *Do not use an extension cord on a cord connected unit.*



WARNING: All electrical work, should only be performed by qualified electrical personnel. Repair to electrical components by non-certified technicians may result in personal injury and/or damage to the unit.

INSTALLATION (cont.)

Optional Accessories and Set Up Configuration

Using the optional accessories not only gives you the ability to customize the cooling application, but also makes the unit work more efficiently.

Unit Installed on the Floor (For Classic 40 and Classic 60)

The unit can be used as a spot cooling system. More information is available at WWW.MOVINCOOL.COM.

1. Standard Configuration

Without stand kit (For Classic 40 and Classic 60)

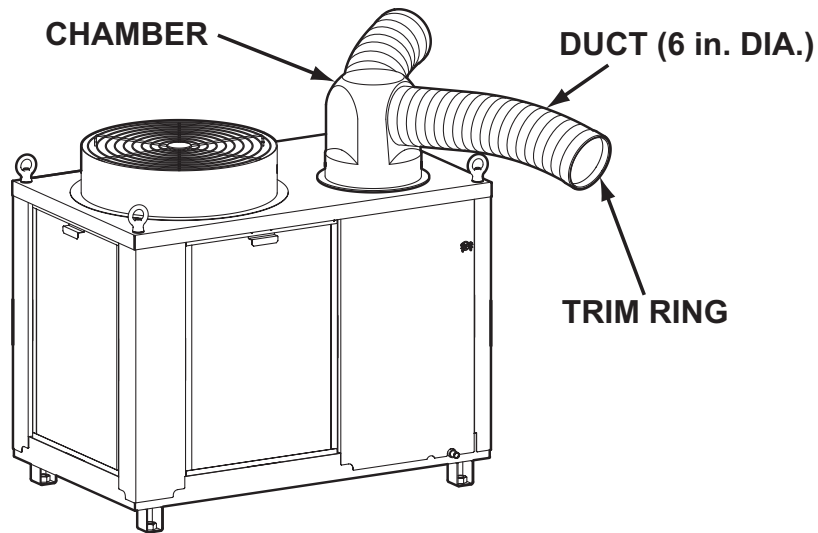

With stand kit (For Classic 40 ONLY)

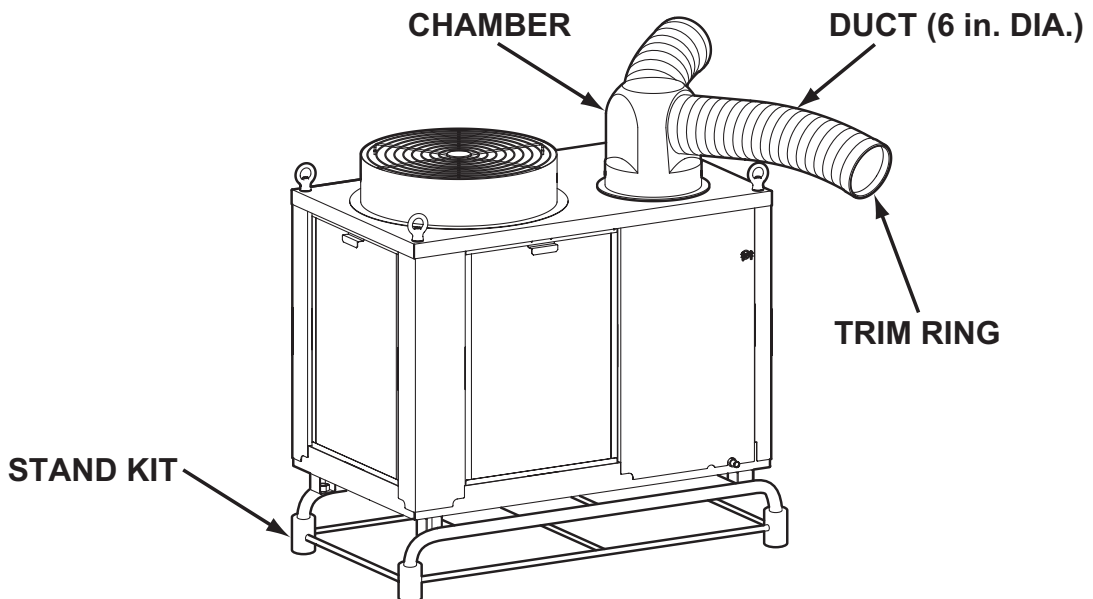

Note: The maximum length of each duct is 6.6 ft. (2 m).

INSTALLATION (cont.)

Optional Accessories and Set Up Configuration (cont.)

Unit Installed on the Floor (For Classic 40 and Classic 60)

2. Application Configuration

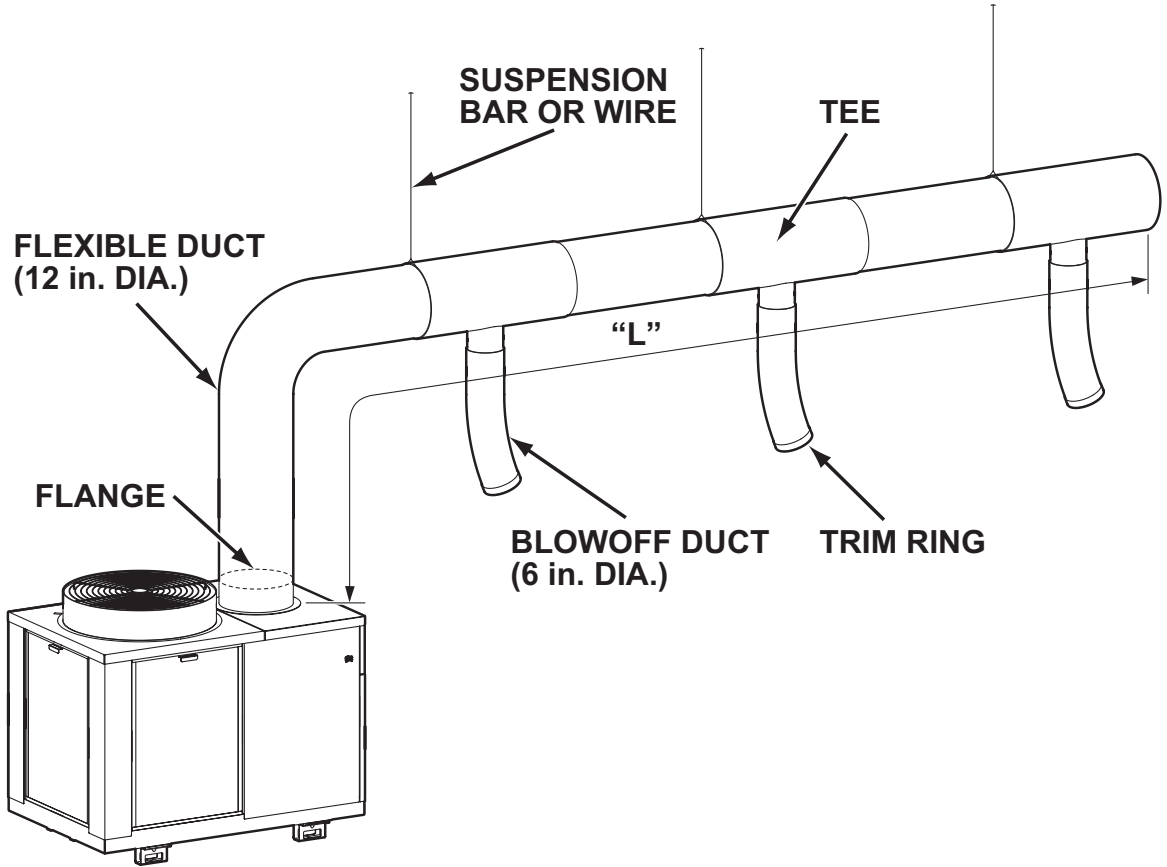

Note: The maximum length of duct "L" is 66 ft. (20 m).

Range of extension static pressure:

Classic 40	0.63 IWG (157 Pa) ~ 1.73 IWG (431 Pa)
Classic 60	0.57 IWG (142 Pa) ~ 1.35 IWG (336 Pa)

Number of blow off ports:

Classic 40	3 ~ 5
Classic 60	4 ~ 7

INSTALLATION (cont.)

Optional Accessories and Set Up Configuration (cont.)

Unit Suspended from the Ceiling (For Classic 40 ONLY)

When the unit is suspended from the ceiling, cooling air can be sent from the bottom of the unit. More information is available at WWW.MOVINCOOL.COM.

WARNING: Make sure that the ceiling structure is capable of supporting the weight of the unit, suspension hardware, and the accessories.

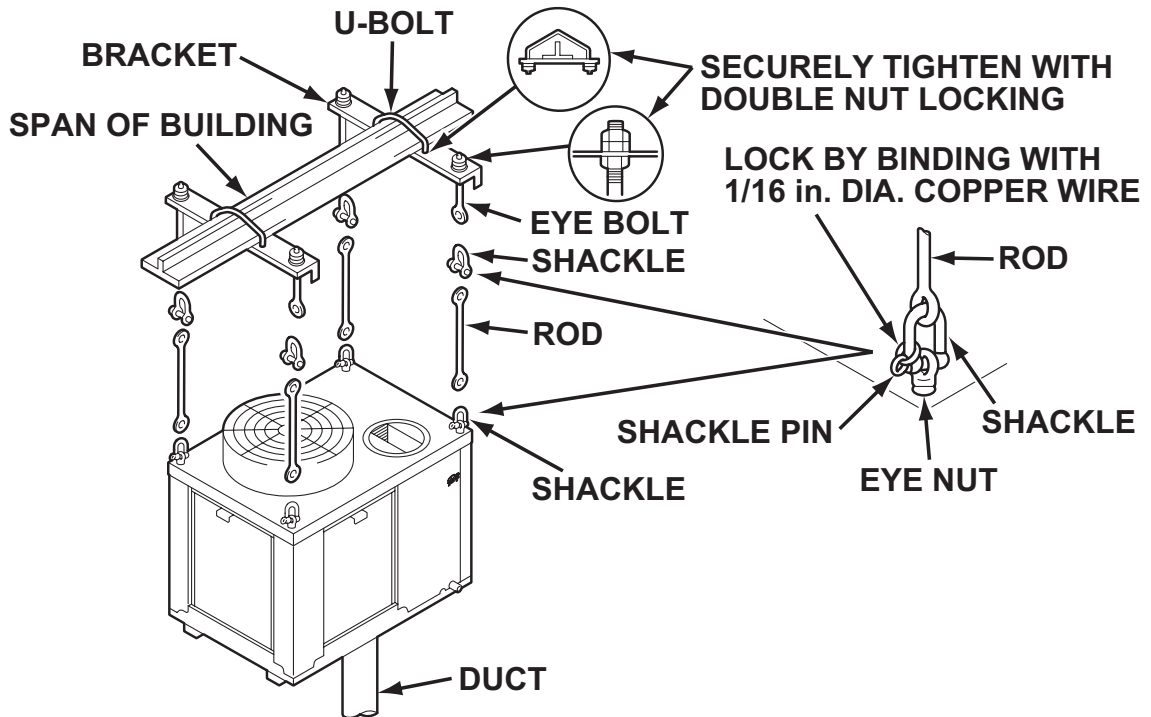

Note:

1. Use standard suspension metal fittings.
2. Do not suspend the unit from the ceiling of a lightweight steel-frame building or wooden building.
3. Make sure to lock the shackle pin with copper wire.
4. Make sure to securely tighten the nut-tightening portion with double-nut locking.
5. If you are uncertain about the strength of ceiling structure, from which the unit is suspended, consult the architect.
6. When working in high places during the installation of unit, provide positive safeguards, such as using a lifeline.
7. After the unit is suspended from the ceiling, make sure that the unit is level. If the unit is not level, adjust each suspension length of the unit with an eyebolt. If the unit slans more than 1.5° horizontally, the drain water will overflow.
8. When the unit is configured as suspended from the ceiling, the signal output can be used with alarm speaker or light indicator to monitor proper operation.

INSTALLATION (cont.)

Optional Accessories and Set Up Configuration (cont.)

Unit Suspended from the Ceiling (For Classic 40 ONLY)

1. Standard Configuration

Note:

1. *The maximum length of one duct is 6.6 ft. (2 m). Suspend the duct as required with wires or suspension bars.*
2. *When installing the drain pipe, make sure it is angled downward for proper drainage.*
3. *Check following items:*
 - *No kinks or bends on the drain hose.*
 - *No trap in the drain hose.*
 - *The end of the drain hose should be higher than the water level at the drain.*
 - *No dripping from the drain hose at the clamping area.*
 - *When installing the unit, empty the drain pan by draining out the water through the drain pan drain pipe.*

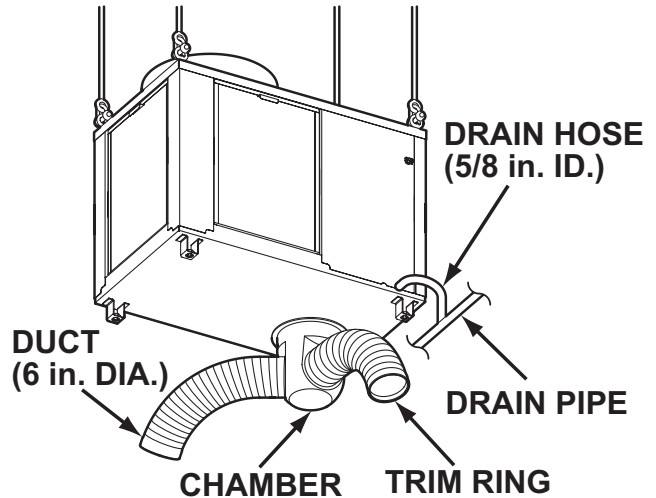

INSTALLATION (cont.)

Optional Accessories and Set Up Configuration (cont.)

Unit Suspended from the Ceiling (For Classic 40 ONLY)

2. Application Configuration

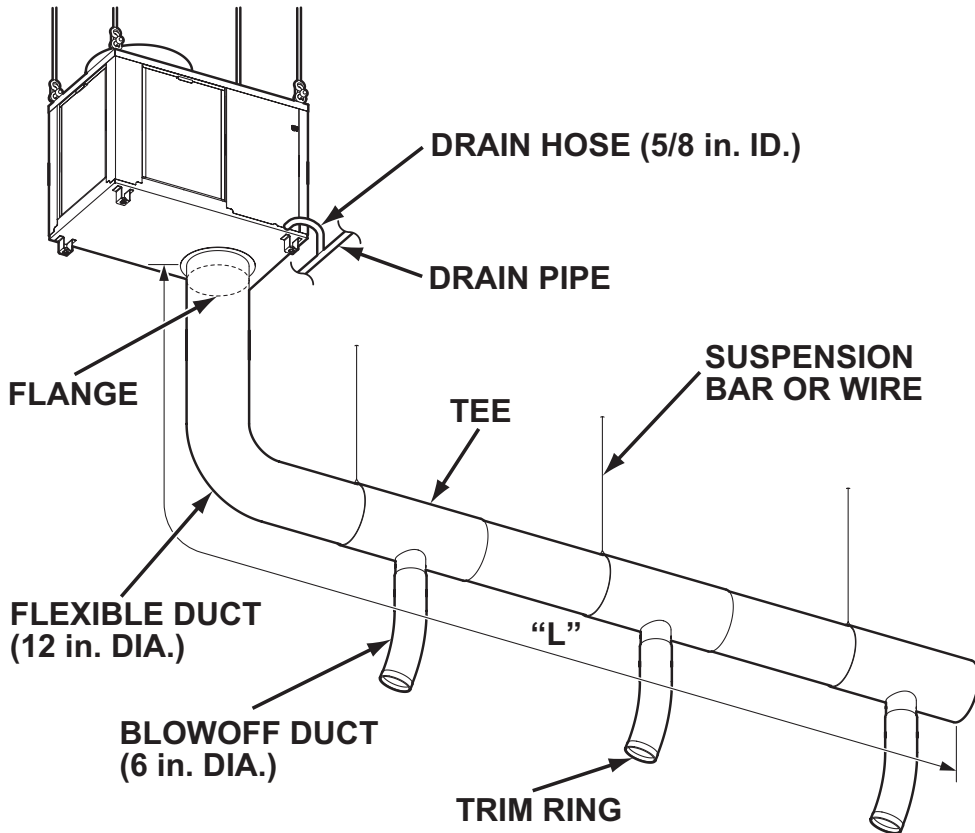

Note: The maximum length of duct "L" is 66 ft. (20 m).

Range of extension static pressure: 0.63 IWG (157 Pa) ~ 1.73 IWG (431 Pa)

Number of blow off ports: 3 ~ 5

INSTALLATION (cont.)

Optional Accessories and Set Up Configuration (cont.)

Unit Suspended from the Ceiling (For Classic 40 ONLY)

3. Duct Work Procedure

Reverse the blower casing inside the unit.

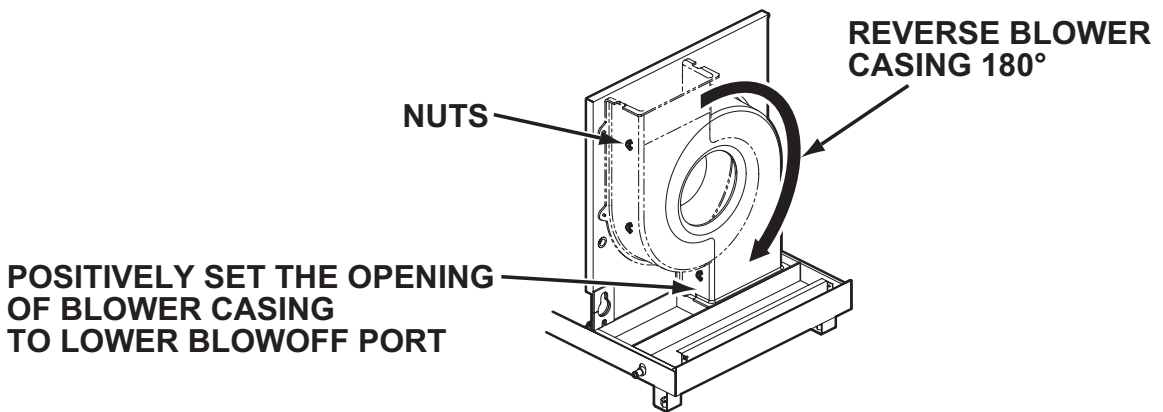
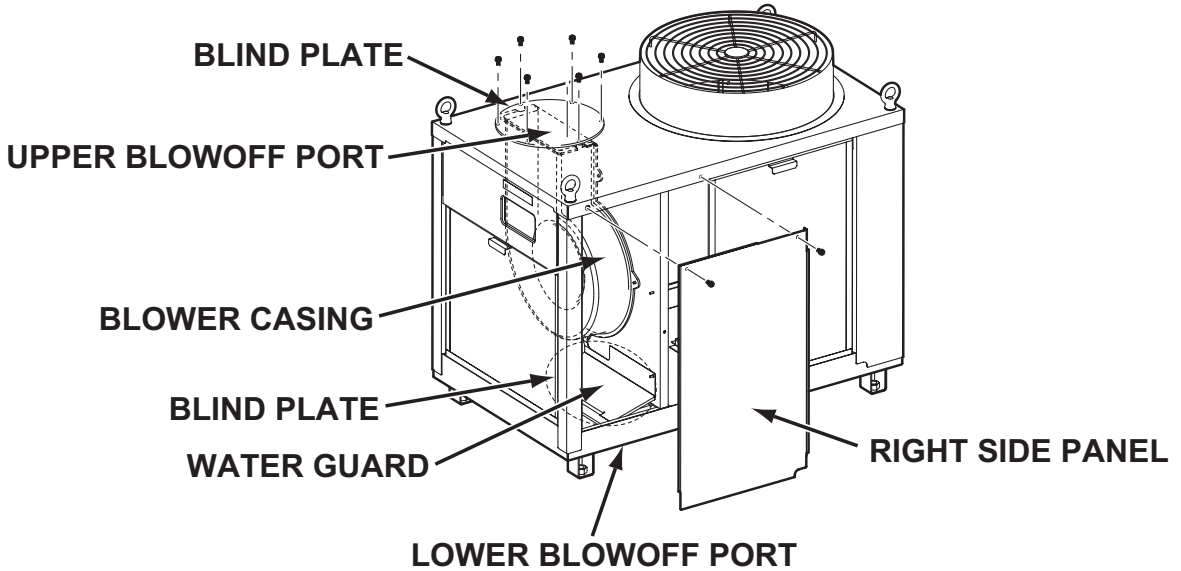

1. Remove the right side panel.
2. Remove the water guard located at the lower blowoff port.
3. Remove the blind plate located at the lower blowoff port and install it to the upper blowoff port, and remove the grill located at the upper blowoff port and install it to the lower blowoff port.
4. Remove five nuts and reverse the blower casing 180°. Then set the opening of blower casing to the lower blowoff port and tighten the blower casing with the nuts.
5. Install the right side panel.

INSTALLATION (cont.)

Optional Accessories and Set Up Configuration (cont.)

Unit Used as a Portable Type

The unit can be used as a portable spot cooling system by attaching the wagon kit or caster kit. More information is available at WWW.MOVINCOOL.COM.

With wagon kit (For Classic 40 ONLY)

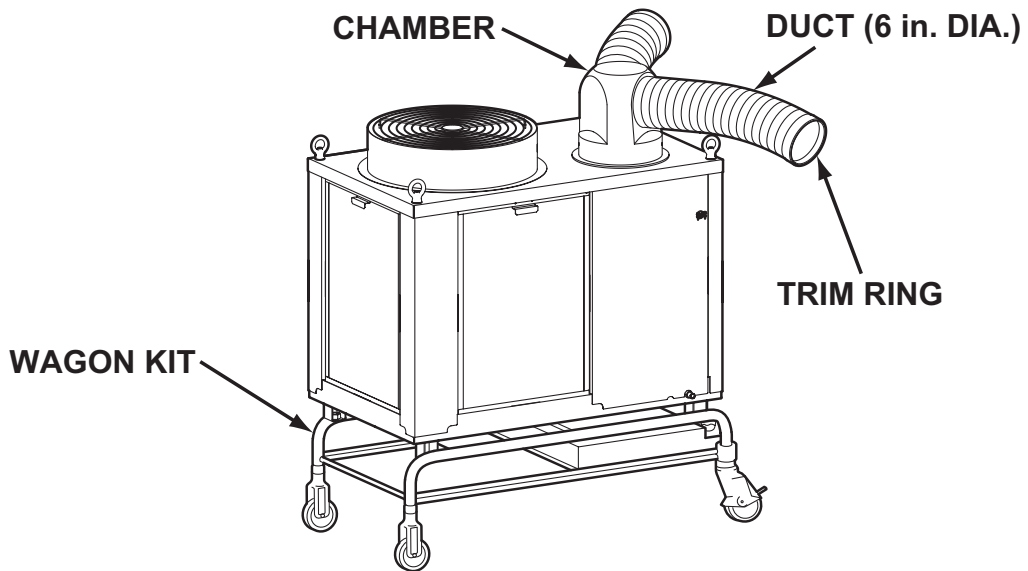

With caster kit (For Classic 40 and Classic 60)

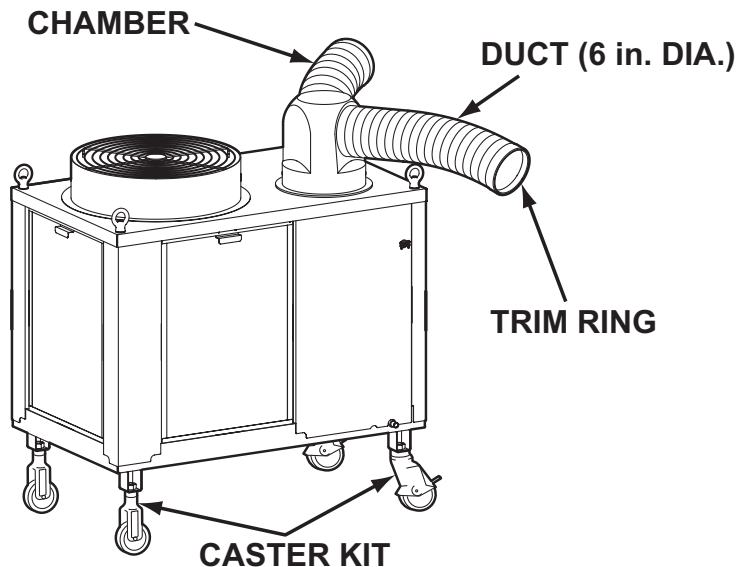

Note:

1. The maximum length of duct is 6.6 ft. (2 m).
2. Do not use the unit in the portable configuration outdoors.

INSTALLATION (cont.)

Optional Accessories and Set Up Configuration (cont.)

Outdoor Installation of the Unit (For Classic 40 and Classic 60)

The unit can be installed outdoors, sending the cool air indoor. More information is available at WWW.MOVINCOOL.COM.

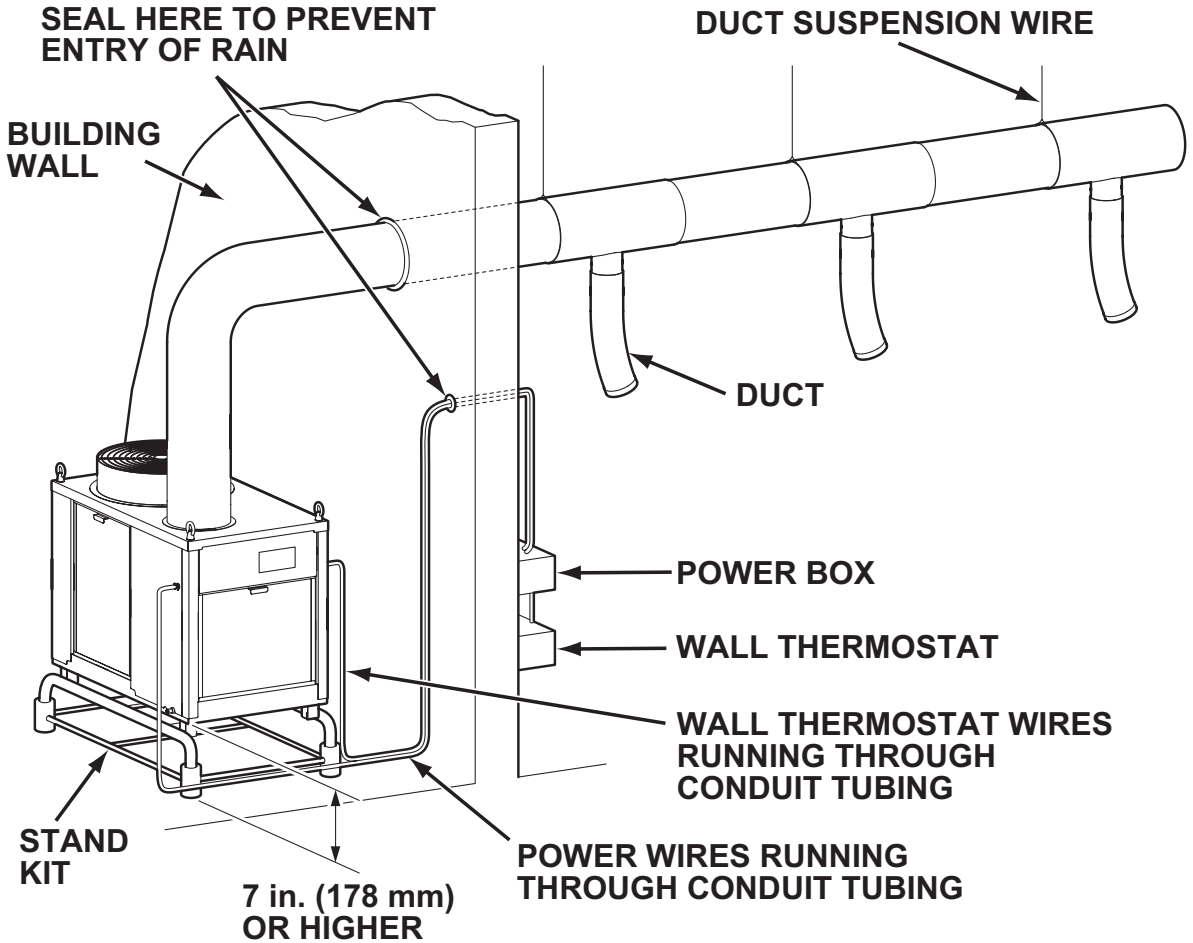

Note:

1. Make sure to run power and remote controller wires through conduit tubing.
2. Make sure to install a residual current operated circuit breaker in the power supply.
3. Completely seal the through holes in the wall for conduit and duct to prevent entry of rain. Use watertight fittings.
4. Do not place the unit directly on the ground. Install the unit at least 7 in. (178 mm) of clearance above ground. The optional standard stand kit (for Classic 40 ONLY) ensures a ground clearance of 7 in. (178 mm) or more.

INSTALLATION (cont.)

Wall Thermostat Connection (Millivolt System ONLY: Option)

Connecting Wall Thermostat to Unit

1. Use with a single stage wall thermostat.
Thermostat type: Millivolt System
2. Remove three (3) screws from the upper panel on the control panel side and open the upper panel.

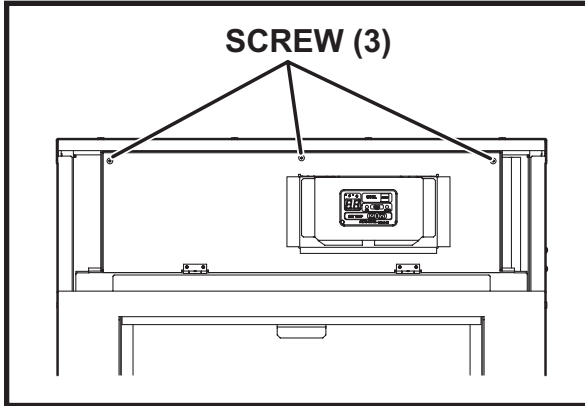

3. Remove two (2) screws and plate from the right side panel.

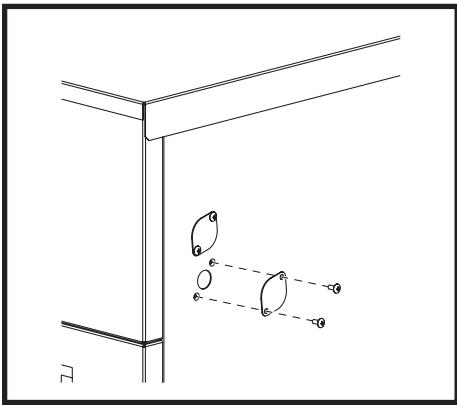

Insert the wire harness through the clip, grommet, and hole in the right side panel.

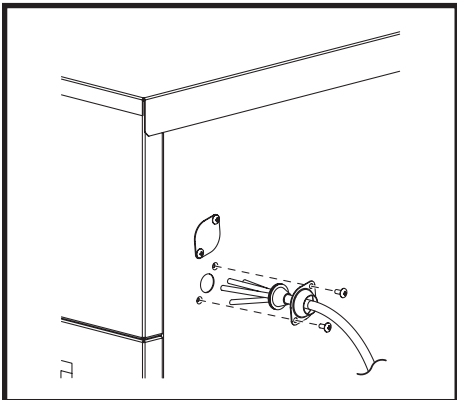

INSTALLATION (cont.)

Wall Thermostat Connection (Millivolt System ONLY: Option) (cont.)

Connecting Wall Thermostat to Unit

- Set the wall thermostat to cooling system mode, since most wall thermostats are designed for both heating and cooling.
- Prepare the wire harness for connection from the unit to the thermostat.
Recommended wire type and size: Thermostat cable / Solid wire 16 ~ 26 AWG
- Identify the thermostat connectors labeled G, Y, and RC.
G (Fan On/Off), Y (Cooling On/Off) and RC (Cooling Transfer - Common)

Wall Thermostat Connector Name	Unit Connector Name	Function
RC	RC	Common
Y	Y	Cool On/Off
G	G	Fan On/Off

- Connect the wire harness from the terminal of the unit to the thermostat according to the labels shown below.

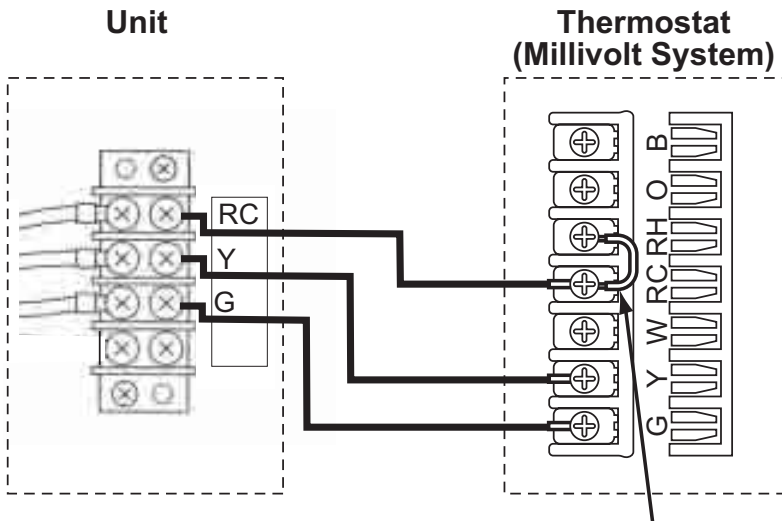

Remove Factory-Installed Jumper

Note: Use thermostat that is compatible with millivolt system. Do not connect thermostat to AC power source.

INSTALLATION (cont.)

Wall Thermostat Connection (Millivolt System ONLY: Option) (cont.)

Connecting Wall Thermostat to Unit

8. Install the wall thermostat to the proper location inside the room where it can be conveniently accessed. Do not install the wall thermostat where unusual heating conditions may occur (i.e. hot stove, hot pipe, fireplace, direct sunlight, etc.)

Most thermostats provide these basic functions:

Fan Mode: On / Auto (Select the desired fan mode)

System: Cool / Heater (Select Cool only)

For wall thermostat operation, see the operation manual supplied with the wall thermostat.

Setting The Unit for Wall Thermostat Connection

1. Press and hold FAN button, SET TEMP UP \triangle and DOWN ∇ buttons simultaneously to activate wall thermostat connection.
2. Press SET TEMP UP \triangle button to select "Sb" indicates on LED display for wall thermostat enable function. ("Ho" indicates on display for wall thermostat disable function.)
3. Press COOL button to set wall thermostat function. If COOL button is not pressed within 10 sec., the setting is automatically confirmed.

INSTALLATION (cont.)

Warning Signal Connection (Output Signal Terminal L+ and L-)

The controller is equipped with a warning signal output relay type (Form C, normal open dry contact) which can be used to monitor the failure condition.

Note: When the unit is configured as suspended from the ceiling, the signal output can be used with alarm speaker or light indicator to monitor proper operation.

Relay contactor is closed when the unit operates abnormally.

The relay output contactor is rated 2 A at 30 VDC or 2 A at 30 VAC (resistive load) and it is compatible with various warning devices such as alarm speaker, light indicators, etc.

Connecting Warning Signal from Controller

1. Remove three (3) screws from the upper panel on the control panel side and open the upper panel.

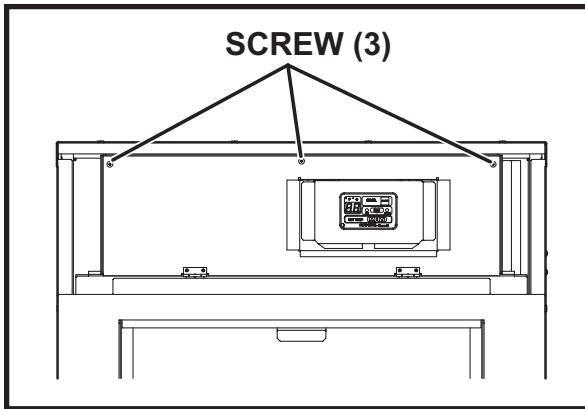

2. Remove two (2) screws and plate from the right side panel.

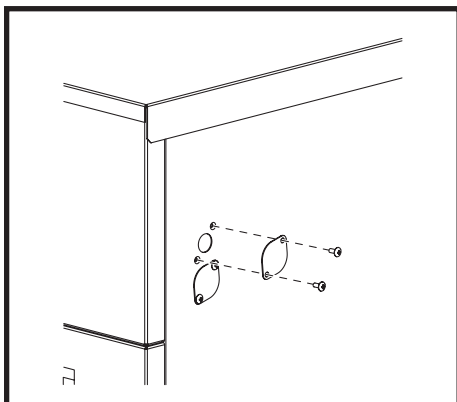

INSTALLATION (cont.)

Warning Signal Connection (Output Signal Terminal L+ and L-) (cont.)

Connecting Warning Signal from Controller

3. Insert the warning signal wire through the clip, grommet, and hole in the right side panel.

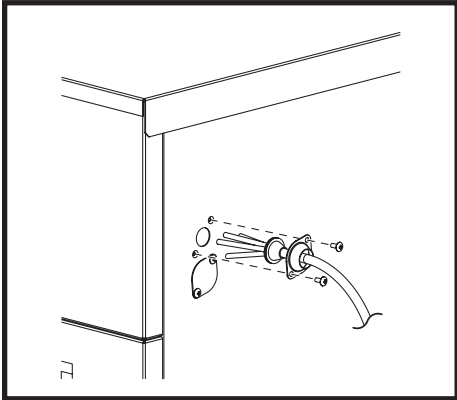

Note: Use recommended warning signal wire size from 16 AWG to 26 AWG for a solid wire, or 16 AWG to 22 AWG for a stranded wire with ring terminal for #6 stud size.

4. Connect the warning device to terminal L+ and L- according to its polarities.

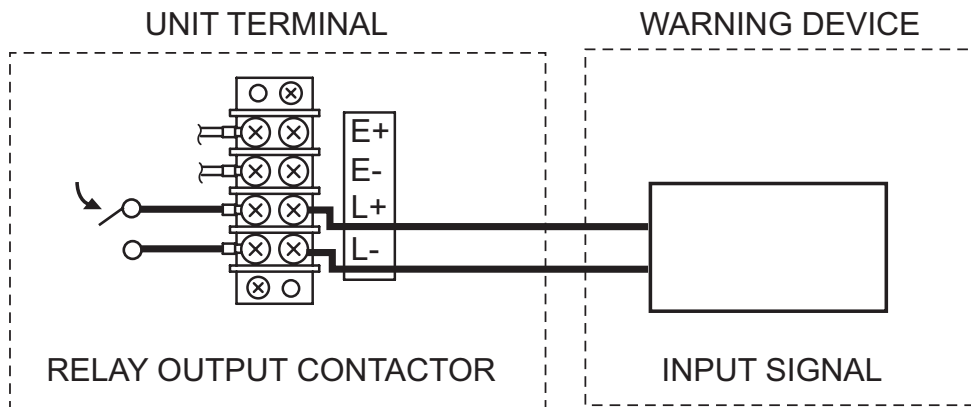

INSTALLATION (cont.)

Fire Alarm Control Panel Connection (Input Signal Terminal E+ and E-)

The controller is equipped with a normal open input signal connection, which can be connected directly from the fire alarm control panel. This input signal terminal should only be connected to a close or open dry contact signal. When receiving the signal from the fire alarm control panel, the unit turns off and does not turn back on until it has been RESET.

Connecting Fire Alarm Control Panel to Controller

1. Remove three (3) screws from the upper panel on the control panel side and open the upper panel.

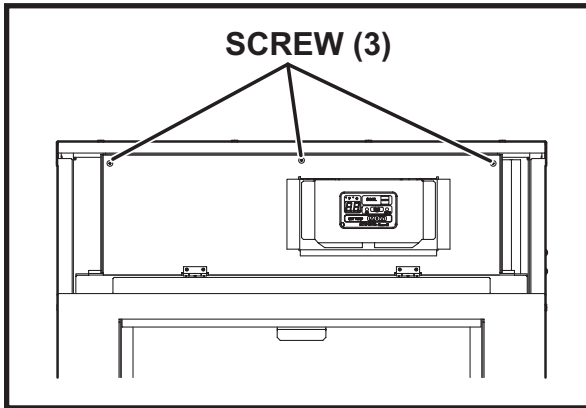

2. Remove two (2) screws and plate from the right side panel.

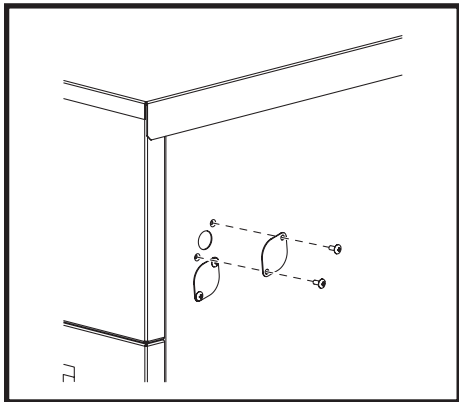

INSTALLATION (cont.)

Fire Alarm Control Panel Connection (Input Signal Terminal E+ and E-) (cont.)

Connecting Fire Alarm Control Panel to Controller

3. Insert the fire alarm signal wire through the clip, grommet, and hole in the right side panel.

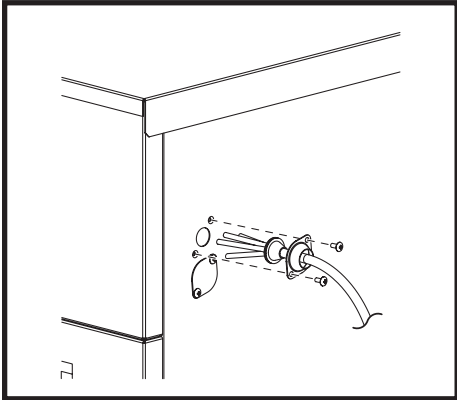

Note: Use recommended fire alarm signal wire size from 16 AWG to 26 AWG for a solid wire, or 16 AWG to 22 AWG for a stranded wire with ring terminal for #6 stud size.

4. Connect the fire alarm device to terminal E+ and E- according to its polarities.

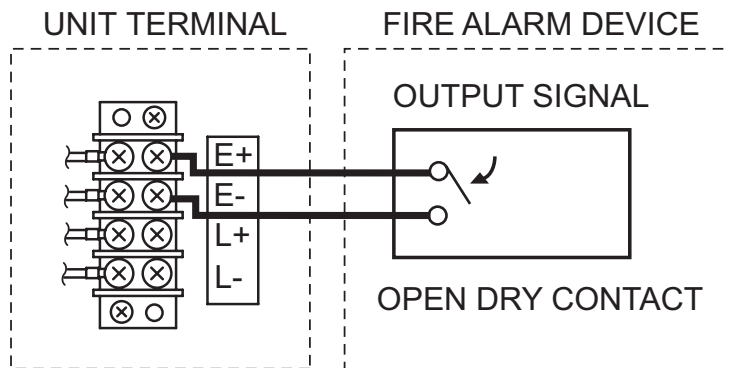

OPERATION

Features

1. A digital electronic control panel, which allows the user to easily control the unit's operation.
2. Digital LED display that indicates:
 - a. Room temperature and set point temperature (either Fahrenheit or Celsius)
 - b. Status codes
3. The set point temperature can be adjusted between 75 °F (24 °C) and 95 °F (35 °C) by the SET TEMP buttons (Δ/∇).
4. Fire alarm control panel connection with automatic shut off.
5. Automatic shut off, warning signal output and alarm for temperature sensor failure, lose of cooling, and conditions of self-diagnostic codes.
6. An automatic restart feature when the power is lost and regained. The unit returns to the operating mode it was in prior to the loss of power.
7. Enable and disable function for wall thermostat connection.

OPERATION (cont.)

Control Panel

Before operating the unit, it is important to familiarize yourself with the basic controls located on the control panel.

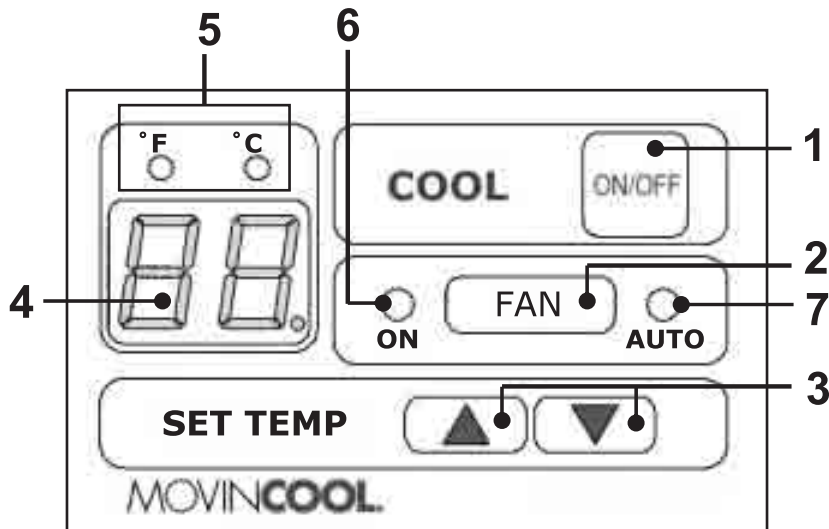

- | | |
|---|--|
| 1. COOL ON/OFF Button | Activates COOL mode or turns the unit off. |
| 2. FAN Button | Activates FAN ONLY mode or turns the unit off. |
| 3. SET TEMP Buttons (Δ/▽) | Increases or decreases the temperature set point during COOL mode. |
| 4. Room Temperature/ Set Point Display | Displays a flashing set point temperature for 5 sec, and then continuously indicates the room temperature. |
| 5. Temperature Scale LED | Lit to indicate the current temperature being displayed in either °F or °C. |
| 6. ON LED | Turns on during FAN ONLY mode and during COOL mode with Fan Operate mode. |
| 7. AUTO LED | Turns on during COOL mode with FAN STOP mode. |

OPERATION (cont.)

Control Panel (cont.)

LED Display Descriptions

In normal operation, the LED displays the following descriptions.

Display	Descriptions	Conditions
.	Right decimal point is on.	Standby or FAN ONLY mode.
0	Indicates wall thermostat enable function is set.	Lit during wall thermostat connection.
78	Indicates room temperature when display is lit. (Left fig. : Room temperature at 78 °F)	During COOL mode.
75	Indicates set point temperature when display is flashing for 5 sec. (Left fig. : Set point temperature at 75 °F)	During set point temperature adjustment.

Note: The ROOM TEMP display range is from 0 °F (-9 °C) to 109 °F (60 °C). When the display value is greater than 99 °F, it displays values of 00 for 100 °F, 01 for 101 °F, and 09 for 109 °F. (This only applies to Fahrenheit values.)

OPERATION (cont.)

Operating Modes

The Classic 40 and Classic 60 can be operated in two modes, FAN ONLY and COOL. When in FAN ONLY mode, the unit circulates the surrounding air. When in COOL mode, the compressor is operated and cool air is circulated.

1. COOL Mode

Once the compressor has been disengaged for more than 120 sec, the unit operates in FAN ONLY mode for approximately 5 sec before the compressor re-engages.

2. Temperature Control

The room temperature thermistor monitors the inlet temperature versus set point temperature and switches the unit automatically between COOL and FAN ONLY modes.

3. Fan Mode Control DIP Switch

The fan mode control DIP switch determines whether the fan continues to operate or stop when the compressor cycles off. (Set point temperature below the inlet air or room temperature.) The unit has been preset at the factory for continuous fan operation.

Note: If you want to change the fan mode operation (from OPERATE to STOP), contact your MovinCool reseller.

4. Temperature Scale Display

The temperature scale display changes the temperature(s) that are displayed to either °C or °F. The unit has been preset from the factory to display the temperature(s) in °F.

Note: If you want to change the temperature scale display (from °F to °C), hold down the SET TEMP buttons (Δ/▽) and the FAN button simultaneously for 3 sec.

OPERATION (cont.)

Operating in COOL Mode

1. The unit can be operated in COOL mode by pressing the COOL ON/OFF button.

Note: In COOL mode the unit can only be turned off by pressing the COOL ON/OFF button.

2. Change the temperature set point by pressing the SET TEMP buttons (Δ/∇).

Note: When turning the unit on, the set point and operation mode are determined by the last operating mode.

Operating in FAN ONLY Mode

1. The unit can also be operated in FAN ONLY mode by pressing FAN button.
2. The unit can only be turned off by pressing the FAN button again.

Changing from FAN ONLY Mode to COOL Mode







The COOL mode can be activated while the unit is operating in FAN ONLY mode. To do this, simply press the COOL ON/OFF button.

Note: The FAN ONLY mode does not operate after the COOL mode has been activated. The unit can only be turned off by pressing the COOL ON/OFF button.

OPERATION (cont.)

Self-Diagnostic Codes

Self-diagnostic codes are displayed on the control panel under the following conditions:

LED Display Codes	Condition
	When room thermistor becomes open or shorted, display shows “E1” and cool mode operation is off. Display and cool mode operation are returned to normal operation after room thermistor is fixed.
	When freeze thermistor becomes open or shorted, display shows “E2” and cool mode operation is off. Display and cool mode operation are returned to normal operation after freeze thermistor is fixed.
	When the protective device is activated, the LED displays “E4” and cool mode operation is off.
	When lose of cooling occurs 3 times, the unit displays “CF”. The unit returns to normal operation after the problem is fixed and the controller is RESET. To RESET: Hold down the SET TEMP (Δ/▽) buttons simultaneously for 3 sec., and the controller returns to normal operation.
	When high pressure switch is activated 3 times , the unit displays blinking “HP” and after 10 times in 24 hr., “HP” turns on. The unit returns to normal operation after the problem is fixed and the controller is RESET. To RESET: Hold down the SET TEMP (Δ/▽) buttons simultaneously for 3 sec., and the controller returns to normal operation.
	When the fire alarm control panel input signal is CLOSED, the unit turns off, the LED displays “AL”, and the buzzer turns on. Once input signal is OPENED and unit has been RESET or the wall thermostat has been turned off and on, the unit returns to normal operation. To RESET: Hold down the SET TEMP (Δ/▽) buttons simultaneously for 3 sec, and the controller returns to normal operation.

Contact your MovinCool reseller or a qualified technician if problem persists.

DAILY INSPECTION & MAINTENANCE

Clean the Air Filters

Clean the air filters once a week. If the unit is used in a dusty environment, more frequent cleaning may be required.

A dirty air filter can reduce air output resulting in a decrease in cooling capacity.

Filter Removal Method

1. Turn the unit off, by pressing the COOL ON/OFF button.
2. Remove the air filters.

Note: To remove four air filters, lift upward, then pull outward from the bottom.

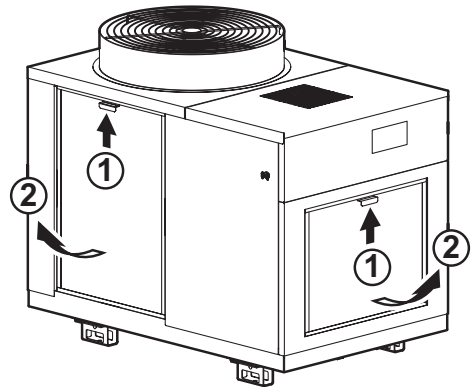

3. Remove the element from each filter.

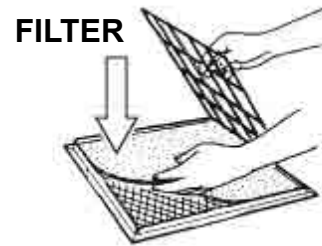

Filter Element Cleaning Method

1. Remove dust from the element with a vacuum cleaner, or rinse in cold or lukewarm water. If the element is extremely dirty, wash with a neutral detergent.
2. After the element has been cleaned, rinse with clean running water, allow to dry, then reinstall.

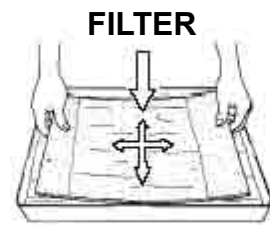

DAILY INSPECTION & MAINTENANCE (cont.)

In-Season/Off-Season Inspection & Maintenance



WARNING: To prevent an accident due to electrical shock, perform inspection and maintenance only after turning off the power at the circuit breaker or unplug the power cord.

In-Season

1. Check the prongs and surface of the power cord plug for dust and/or dirt. If dust and/or dirt are present, wipe off with a clean dry cloth.
2. Check the power cord, plug and prongs for damage or excess play. If any damage or excess play is found, contact your MovinCool reseller or a qualified technician for repair.
3. Check the air filters.
4. Clean the outside of the unit(s) with a damp cloth or mild nonabrasive cleaner.



WARNING: Do not clean the unit directly by pouring water on electrical parts such as control panel and relay box. This could result in poor insulator causing electrical shock or leakage.

5. Check the looseness and clogging of drain pipe. If the drain pipe is loose or clogged, take corrective action so that drain water flows freely.
6. Check the looseness of each connection terminal inside the control box. Fully check the following terminals.
 - Main terminal
 - Grounding terminal
7. Test the power supply ground fault breaker at least once a month.
8. Check if abnormal noise or vibration is generated from the unit and also check for missing or loose nuts. After the start or stop of operation, the unit may make a gurgling sound. This sound is generated by refrigerant inside the unit and does not indicate machine trouble.

DAILY INSPECTION & MAINTENANCE (cont.)

In-Season/Off-Season Inspection & Maintenance (cont.)

Off-Season

1. Operate the unit in FAN ONLY mode for 8 hr.
Note: Operation is necessary to dry out the inside of the unit.
2. Disconnect the power cord from the AC outlet.
3. Check the prongs and surface of the power cord plug for dust and/or dirt. If dust and/or dirt are present, wipe off with a clean dry cloth.
4. Check the power cord, plug and prongs for damage or excess play. If any damage or excess play is found, contact your MovinCool reseller or a qualified technician for repair.
5. Clean the air filters.
6. Turn off the power at the circuit breaker.

TROUBLESHOOTING

Check the following items before calling your MovinCool reseller or a qualified technician.

SYMPTOM	POSSIBLE CAUSE	REMEDY
Unit does not operate	1. Power supply is off	Check circuit breaker.
	2. Incorrect power phase sequence	Check connection or exchange two wires of R, S and T.
	3. Power interruption	Unit will turn on automatically when power returns (Some thermostats require to be reset).
	4. Blockage of air duct	Check duct for any blockages or excessive kinks in ducting.
	5. Turn off signal input	Check for turn off signal input (fire alarm control panel).
	6. High pressure switch activated 10 times in 24 hr.	<ol style="list-style-type: none"> 1. Clean air filter. 2. Check inlet and outlet air, and make sure that there were no object that may prevent air flow into or out of the unit. 3. Check environmental condition to ensure it is within operating range. 4. RESET controller. To RESET: Hold down the SET TEMP (Δ/∇) buttons simultaneously for 3 sec., controller returns to normal operation.
	7. Battery ran out on thermostat (when wall thermostat is used).	Change battery.
	8. Wall thermostat enable function and / or improper wiring connection	Check wall thermostat wiring connection and unit setting. (See "Wall Thermostat Connection" section.)
Insufficient Cooling / Unit operation interrupted frequently.	1. Air inlet/outlet blocked.	Clean air inlet/outlet.
	2. Dirty / Blocked filters	Clean / replace air filter.
	3. Improper temperature setting	Adjust temperature setting.
	4. Outside of operating range	Use within operating temperature range.

TROUBLESHOOTING (cont.)

SYMPTOM	POSSIBLE CAUSE	REMEDY
Alarm coming from unit and unit stops.	Receiving fire alarm signal input	Make sure the input signal is OPENED. RESET the unit or turn the wall thermostat off and on. The unit returns to normal operation. To RESET: Hold down the SET TEMP (△/▽) buttons simultaneously for 3 sec.

If symptoms persist after the above actions have been taken, turn the unit off, disconnect the power and contact your MovinCool reseller or a qualified technician.

TROUBLESHOOTING (cont.)

Installation Check Sheet

		ITEMS	✓
Installation	Unit	Check and make sure all screws are tight and unit is secured in place.	
		Check and make sure inlet / outlet air exhaust are clear without blockage.	
	Wiring	Check and make sure the unit is properly connected to the dedicated circuit breaker.	
		Check and make sure all wiring are properly connected to R, S and T and secured.	
		Check and make sure ground wire is tighten and secured.	
	Drain Hose Connection	Check and make sure that heat insulator which is provided with drain hose prevents condensation on hose surface.	
	Wall Thermostat (Option)	Check and make sure wall thermostat is connected properly to unit.	
		Check for incorrect power supply polarity or setting for wall thermostat.	
Test Operation	Check power connection	If the unit does not enter the stand-by mode after the power is turned on, exchange two wires of R, S and T (L1, L2 and L3).	
	Check Operation with Wall Thermostat	Set wall thermostat to Fan On or Fan Only mode to confirm fan only mode operation.	
		Set wall thermostat to Fan Auto or Cool mode operation. During cool mode operation, check and confirm cooling operation after delay timer is expired. (Note: Delay timer vary from 2 ~ 5 min. depending on thermostat model used.)	
	Abnormal Noise	Check and observe abnormal noise during Blowing/Cooling operation.	
	Drain	During cooling operation, check and observe condensation drip through normal drainage path.	
	Air Leakage	Check for air leakage from duct and duct connection.	

TECHNICAL SPECIFICATIONS

ITEMS/FEATURES	Classic 40	Classic 60
Rating Conditions Dry bulb Wet bulb Humidity	95 °F(35 °C) 83 °F(28 °C) (60 %RH)	95 °F(35 °C) 83 °F(28 °C) (60 %RH)
Specifications Power frequency Line voltage Power consumption Current consumption Power factor Starting current Power wiring Recommended fuse size	60 Hz 3 Phase 220 V 4.20 kw 14.0 A 79 % 72 A 12 (4-core) AWG 25 A	60 Hz 3 Phase 460 V 5.90 kW 8.8 A 84 % 65 A 12 (4-core) AWG (Recommended wire size) 20 A
Cooling Unit Cooling capability Cooling system	39,000 Btu/h (11,400 W) Direct Expansion	60,000 Btu/h (17,600 W) Direct Expansion
Blower Type of fan: Evaporator Condenser Air volume: Evaporator Condenser Motor output: Evaporator Condenser	Centrifugal Fan Propeller Fan 1,060 CFM (1,800 m ³ /h) ^{*1} 2,650 CFM (4,500 m ³ /h) ^{*2} 0.75 kW 0.40 kW	Centrifugal Fan Propeller Fan 1,580 CFM (2,680 m ³ /h) ^{*3} 3,800 CMF (6,460 m ³ /h) ^{*4} 0.75 kW 0.40 kW
Compressor Type Output Refrigerant type Refrigerant capacity	Hermetic Scroll 2.30 kW R-410A 3.90 lb (1.77 kg)	Hermetic Scroll 3.89 kW R-410A 5.50 lb (2.50 kg)

*1: Rated at external static pressure 0.63 IWG (157 Pa).

*2: Rated at external static pressure 0 IWG (0 Pa).

*3: Rated at external static pressure 0.57 IWG (142 Pa).

*4: Rated at external static pressure 0 IWG (0 Pa).

TECHNICAL SPECIFICATIONS (cont.)

ITEMS/FEATURES	Classic 40	Classic 60
Safety Devices Compressor overload protector Fan motor protector Anti-freezing thermistor Automatic restart (power interruption) Compressor time delay High pressure interruption Signal input/output Lose of cooling Phase reverse protector	Included Included Included Included 120 sec Included Included Included Included	Included Included Included Included 120 sec Included Included Included Included
Dimensions & Weight W×D×H Weight	25.8 × 43.5 × 38.0 in (656 × 1,106 × 965 mm) 344 lb (156 kg)	31.7 × 49.4 × 42.4 in (804 × 1,254 × 1,077 mm) 474 lb (215 kg)
Operating Conditions Inlet air: Maximum Minimum	113 °F (45 °C), 50 %RH 75 °F (24 °C), 50 %RH	113 °F (45 °C), 50 %RH 75 °F (24 °C), 50 %RH
Control Device Temperature control	Included	Included
Wall Thermostat Type (Option)	Millivolt System	Millivolt System



LIMITED WARRANTY

DENSO SALES CALIFORNIA, INC. (“DENSO”) warrants its MOVINCOOL Products only to the extent stated in its official written warranties. Unless otherwise specifically provided in writing by DENSO, DENSO warrants to end-user that the Products shall be free of defects in materials or workmanship and will function in accordance with DENSO’s published specifications under ordinary intended use and service for a period of twelve (12) months after delivery to the end-user; provided, however in the case of the compressor element of the Products such warranty shall be for a period of thirty six (36) months after delivery to the end-user. DENSO shall, at its sole option, repair or replace any defective Product covered by this warranty. Such remedy shall be end-user’s sole remedy with respect to any particular defect in the Products.

This warranty does not cover defects or malfunctions which result from causes beyond DENSO’s control, including, without limitation, (i) unusual physical or electrical stress; (ii) accident, neglect, abuse, misuse or other abnormal use; (iii) failure to perform routine maintenance in accordance with DENSO’s recommended procedures; (iv) normal wear and tear; (v) repairs or attempted repairs by an unauthorized person; (vi) modifications or alterations to the Products; (vii) use with supplies or devices not supplied or approved by DENSO; or (viii) improper installation or service. This warranty shall extend only to the original end-user and shall be void if any labels or other identifying marks permanently affixed to Products when shipped by DENSO are removed, altered, defaced or obliterated.

The aforesaid warranty is the only warranty made by DENSO with respect to the Products and is in lieu of all obligations or liabilities on the part of DENSO for damages arising out of or in connection with the sale, use or performance of the Products, including, without limitation, any lost profits or any other consequential, incidental, special or exemplary damages of any kind.

DENSO DISCLAIMS ALL OTHER WARRANTIES WITH REGARD TO THE PRODUCTS, INCLUDING ALL IMPLIED WARRANTIES OF MERCHANTABILITY AND FITNESS FOR USE. THERE ARE NO WARRANTIES WHICH EXTEND BEYOND THE DESCRIPTION CONTAINED HEREIN.

PURCHASE DATE: _____

SERIAL NUMBER: _____

DENSO

DENSO SALES CALIFORNIA, INC.

Long Beach, CA 90810

www.movincool.com

P/N: 484007-2972EN

Third Issue: July 2011