

INSTALLATION MANUAL

Condenser Intake Air Plenum Kit (Part No.481769-0221)

FOR CM12

Production Period: From March 2006 (0306) to Present

INVENTORY

After unpacking your plenum kit, please check to make sure you have the following Items.

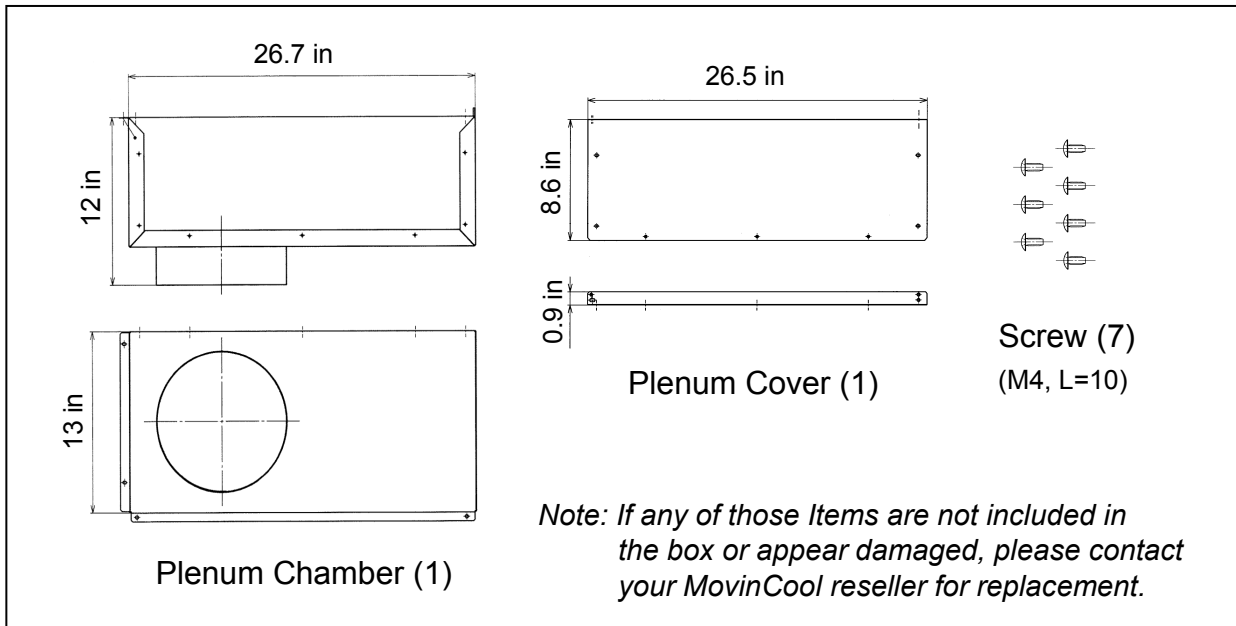

INSTALLATION PROCEDURE

1. Disconnect power from the unit.

⚠ WARNING: Make sure the circuit breaker is turned off.

2. Remove six (6) screws from the unit.

Note: These screws will be reused.

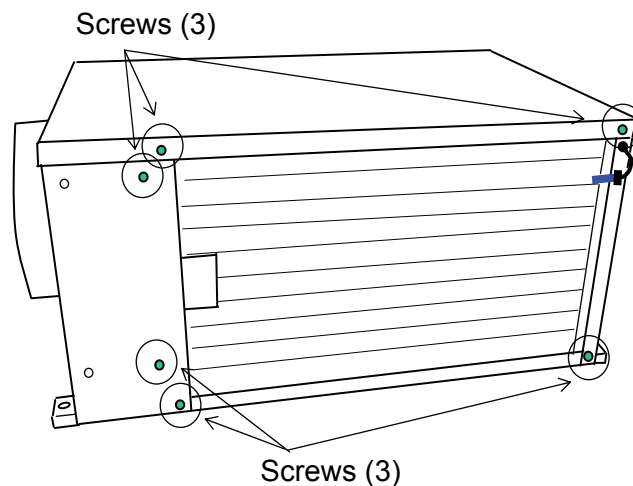

3. Attach the plenum chamber.

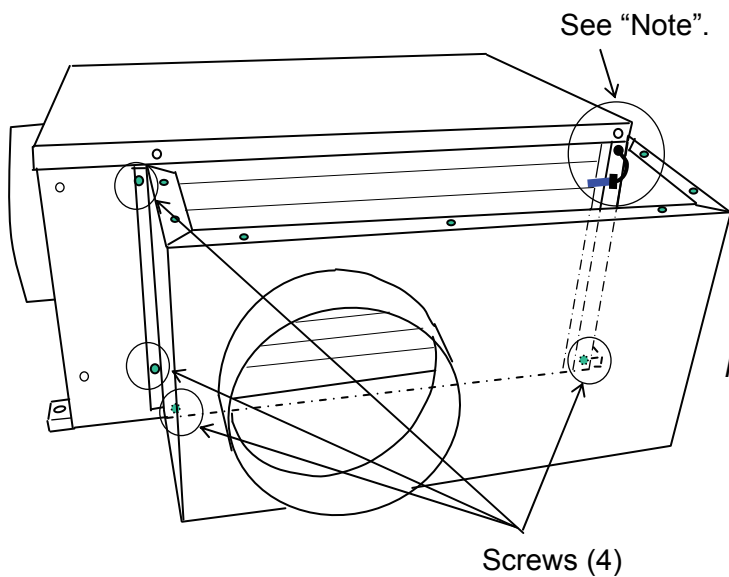

- 1) Attach the plenum chamber.
- 2) Attach four (4) screws in sequence.

Note: Make sure not to fold the wire of the thermistor between this plenum and CM12 body.

4. Attach the plenum cover.

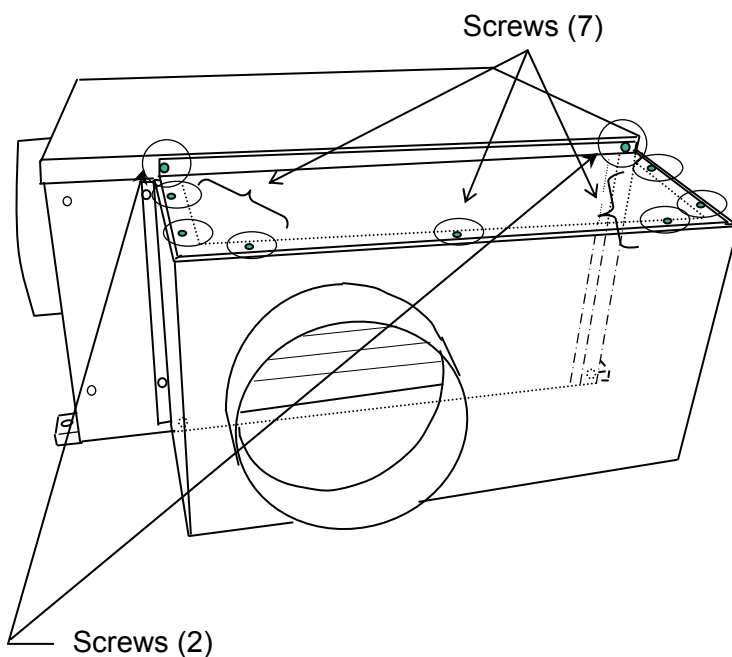

- 1) Attach the plenum cover.
- 2) Attach seven (7) screws to the plenum.
- 3) Attach two (2) screws to the unit according to the table shown below.

Production Period	Use Holes for Plenum Cover
February 2011 (0211) to present	Upper
From March 2006 (0306) to January 2011 (0111)	Lower