



ELECTRIC UNIT HEATERS FOR STANDARD WASHDOWN AND HAZARDOUS (CLASSIFIED) LOCATIONS



MODEL HER



MODEL VE



MODEL PTE



MODEL HEX



MODEL MEW

Table of Contents	Page
Electric Unit Heater Design Benefits	
Introduction	3
Models HER, PTE, VE	4
Model HEX	5
Model MEW	6
Performance/Dimensional Data	
Performance Data - All Units	7
Performance Data - Vertical Unit Air Deflectors	9
Dimensional Data - All Units	10
Accessories - Field Installed - All Units	12
Ordering Information	14
Specifications - All Units	15

Selectable using the Modine Breeze™
AccuSpec Selection Software.



As Modine Manufacturing Company has a continuous product improvement program,
it reserves the right to change design and specifications without notice.

Wide Range of Sizes and Types

Horizontal air delivery unit heater type (HER series):

32 models, 8 sizes from 3 kW through 25 kW.

Recommended for buildings with low ceilings, they are equipped with horizontal air deflector blades to adjust airflow either up or down. Optional vertical deflector blades are also available to deflect air to the right or left, providing complete directional control over discharge of heated air. Horizontal delivery units are normally placed around the perimeter of the building where heat loss is greatest, so that the air stream from each heater "wipes" the wall to produce a blanket of warm air along the outside walls.

Vertical air delivery unit heater type (VE series):

21 models, 9 sizes from 5 kW through 50 kW.

Recommended for buildings with high ceilings are high and where obstructions do not permit good horizontal movement of air. Various optional air deflectors are available to produce a variety of distribution patterns (see page 12). Vertical unit heaters are usually oriented so that the heat spread from one overlaps the heat spread of another unit heater.

Power-Throw™ unit heater type (PTE series):

3 models, 3 sizes from 15 kW through 50 kW.

For applications requiring heat throw greater than can be provided by HER units, Power-Throw™ unit heaters should be considered. For hard-to-heat areas, such as near frequently opened loading dock doors or large warehouses, Power-Throw™ units are frequently an ideal choice. They are equipped with horizontal air deflector blades to adjust airflow either up or down. Due to the higher velocity of discharge air, their air streams should not be directed at room occupants. A single Power-Throw™ unit heater can often be used to replace as many as three smaller horizontal delivery units, thereby reducing equipment, installation, and maintenance costs.

Explosion Proof Horizontal Air Delivery Unit Heater Type (HEX series):

WARNING

Before installing and operating heaters confirm location, classification and properties of flammable vapors, liquids, gases, dusts and fibers which may be present. Each room, section or area should be considered individually.

26 model combinations, 9 sizes from 3 kW through 35 kW.

These horizontal heaters are designed for rugged industrial applications in hazardous locations such as oil refineries, petrochemical plants, pulp and paper mills, coal mines, grain elevators, etc., where the possibility of explosion or fire exists due to the presence of flammable gases, vapors, powdered metals or dusts. Heaters are UL Listed for Class I, Divisions 1 & 2, Groups C and D; Class II, Division 1, Groups E, F and G, and Class II, Division 2, Groups F and G. The UL temperature code shall be T3B 329°F (165°C) for Class I and II, indicating maximum operating surface temperatures. Before selecting any heater for a particular application, refer to Article 500 of the National Electric Code, as well as other applicable Standards. Abbreviated descriptions of UL classes, groups, and divisions are as follows.

Class I: Locations in which flammable gas or vapors may be present, such as, but not limited to:

- Group C: Atmospheres such as ethylene, alcohol, carbon monoxide, or hydrogen sulfide.

- Group D: Atmospheres such as acetone, gasoline, natural gas, propane or other gases or vapors of equivalent hazard.

Class II: Locations in which combustible dusts may be present, such as, but not limited to:

- Group E: Atmospheres containing combustible metal dust regardless of resistivity or other combustible dust of similar hazard characteristics.
- Group F: Atmospheres containing carbon black, charcoal, coal or coke dust or dust of similar hazard characteristics.
- Group G: Atmospheres containing flour, starch, grain dust or dusts of similar hazards.

Division I: Location in which ignitable concentrations of flammable material exist under normal operating conditions.

Division II: Locations in which flammable materials will normally be confined within closed containers and escape only in the case of abnormal conditions. Any equipment approved for Division I is automatically also approved for Division II.

For further information, please consult the National Electric Code (NEC) and National Fire Prevention Association (NFPA) standards.

Low Installation Cost

Transformers, contactors and fuses are factory-furnished and factory-wired when required. Terminal blocks facilitate connection of power supply and control wiring. Modine electric unit heaters are lightweight and require no special reinforcement to suspend them.

Easy to Service

Fan and motor are exposed and can be removed without lowering the unit heater. A hinged bottom panel permits full access to controls on models HER, horizontal units. Vertical delivery and Power-Throw™ models have separate control boxes externally mounted on the units. Motors are totally enclosed, permanently lubricated, and thermally protected. Electrical contactors, fuses, and transformers are all safely enclosed in control compartments.

Application Flexibility

Total Heating

Units can meet the total heating requirement in most industrial plants, commercial and recreational buildings, and in special-purpose structures such as animal shelters. The features that make them the ideal selection for these types of buildings are a long heat throw, uniform heat delivery and low installation and maintenance costs. High up and out-of-the-way, unit heaters provide heat into work areas for clean, safe, economical heating comfort.

Supplemental Heating

They are ideal for spot heating applications during short periods of occupancy in the area to be heated. In out-of-the-way locations, remote from areas served by the building's main heating systems, electric unit heaters can often eliminate the expense of extending gas, steam, or hot water lines.

Stand-by/Back-up Heating

Where fossil fuel supplies are interruptible or undependable, electric unit heaters are recommended as a stand-by or back-up heating system to supply comfort to an entire building or any part of it.

Figure 4.1 - Model HER & PTE Controls and Features

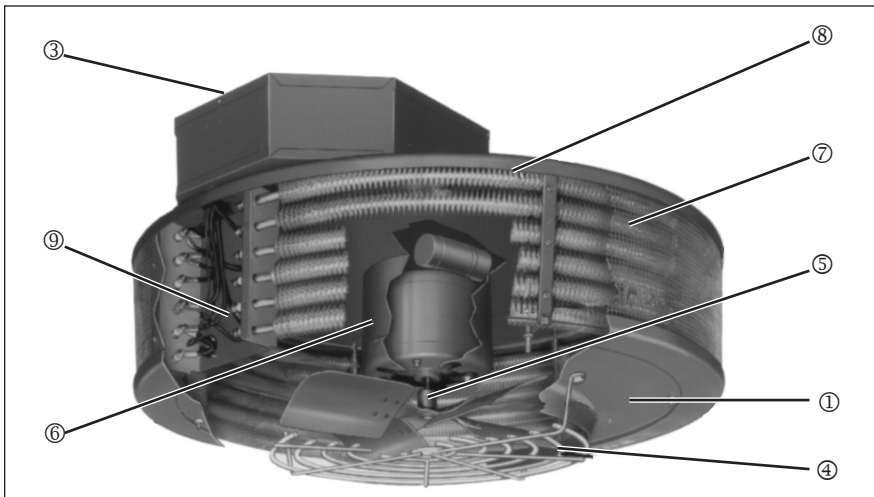
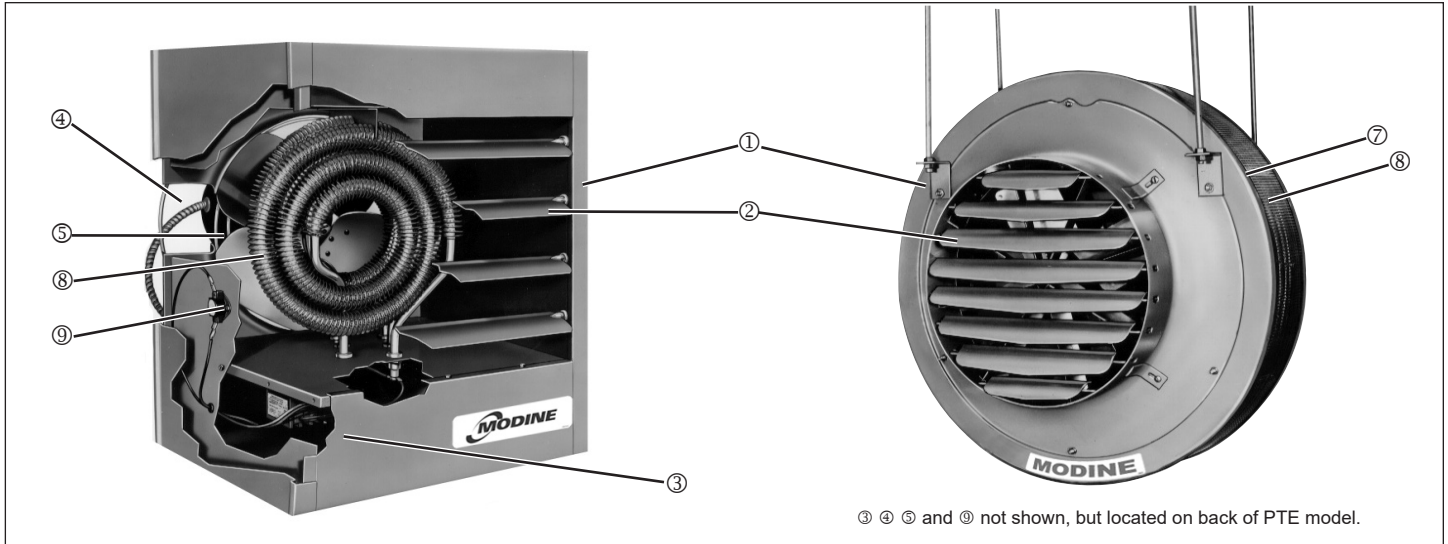

- ① **Casing** - The casing is cleaned and phosphatized prior to electrostatic application of a baked-on, gray-green polyester powdercoat paint.
- ② **Adjustable Air Deflector Blades (HER & PTE units only)** - Adjustable up and down, blades provide control over the horizontal air delivery of the unit heater.
- ③ **Control Compartment** - Safely encloses power and control terminal blocks, contactor(s), fuses and transformer. Terminal blocks provide easy access for field wiring. On model HER horizontal units, a hinged bottom panel swings down for full access to the control compartment.
- ④ **Safety Fan Guard** - Formed from heavy gauge steel rod stock, the fan guard is attached to the unit heater casing and provides a rigid support for the motor and protection from the exposed fan.
- ⑤ **Motor/Fan** - The totally enclosed, thermally protected, continuous-duty motor is mounted to the fan guard utilizing rubber vibration absorbing material. The lightweight aluminum propeller type fan is connected directly to the motor shaft and is statically balanced for peak performance and low sound level.

- ⑥ **Motor Heat Shield (VE units only)** - Protects the motor from heated air passing through the unit heater.
- ⑦ **Protective Screen (VE & PTE units only)** - The aluminum screen protects heating elements from accidental damage and further enhances the appearance of the unit heater.
- ⑧ **Heating Element** - Nickel-chromium wire elements are enclosed in powder-filled aluminum coated steel tubes to which spiraled fins are permanently fused for maximum heat transfer. Elements are resistant to thermal shock and vibration.
- ⑨ **Automatic Reset Overheat Control** - In the event of overheating, this control interrupts the power supply to the heating elements. The control automatically resets itself once the heater cools to a safe temperature. Control includes a switch located in terminal box with a capillary tube around bottom heating element.

Features

Figure 5.1 - Model HEX Controls and Features

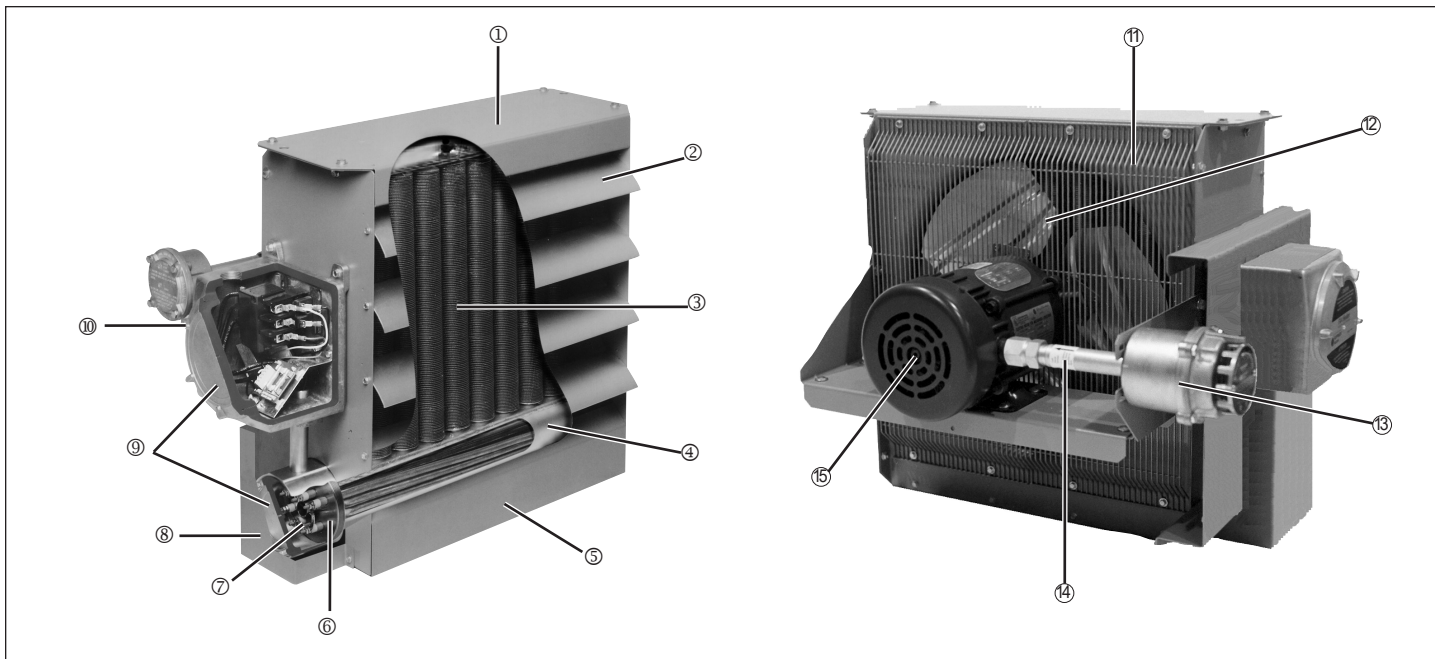

- ① **Epoxy coated 14 gauge steel cabinet** contains heater core, motor, and fan assembly. All fasteners are plated for corrosion protection.
- ② **Adjustable extruded aluminum louvers** allow directional control of airflow.
- ③ **Liquid to air finned tube heat exchanger core.** An Ethylene Glycol and water solution is used as the heat transfer fluid, providing freeze protection to -49°F (-45°C). A pressure relief valve protects the core from overpressure damage. Heaters are UL Listed for Class I, Divisions 1 & 2, Groups C and D, and Class II, Division 1, Groups E, F and G, and Class II, Division 2, Groups F and G. UL temperature code shall be T3B 329°F (165°C) for Class I and II, indicating maximum operating surface temperatures. Refer to page 3 for additional details.
- ④ **Low watt density metal sheathed immersion type heating elements** in the liquid filled lower tank feature a Teflon® liner to keep elements away from outer surfaces. (Teflon® is a registered trademark of E.I du Pont de Nemours & Co.).
- ⑤ **The core** is easily removable through the bottom of the heater for ease of service.
- ⑥ **Automatic reset, bimetal, high-limit** provides over temperature protection and is rated for 100,000 cycles of service.
- ⑦ **Factory wiring** to tin plated copper bus bars for effective handling of high current flow.
- ⑧ **Outer protective cover** protects against high surface temperatures.
- ⑨ **Threaded explosion proof covers** on junction boxes.
- ⑩ **NEMA Type 7 & 9 enclosures** with large, heavy-duty aluminum data plate houses the built-in control transformer, convenient terminals for 120V room thermostat wiring connection, load carrying contactor with severe duty coil, and fuse protection for contactor coil, including a spare fuse in a convenient holder.
- ⑪ **Narrow gap two-piece safety fan guard** shields all moving parts.
- ⑫ **Heavy gauge embossed fan blades.**
- ⑬ **Optional factory installed explosion proof thermostat.**
- ⑭ **Factory wired motor connections** with copper conductor wires enclosed in steel conduit. Conduit is reverse threaded for easy motor removal.
- ⑮ **Thermally protected, automatic reset explosion-proof motor**

Teflon® is a registered trademark of E.I du Pont de Nemours & Co.

Features

Figure 6.1 - Model MEW Controls and Features

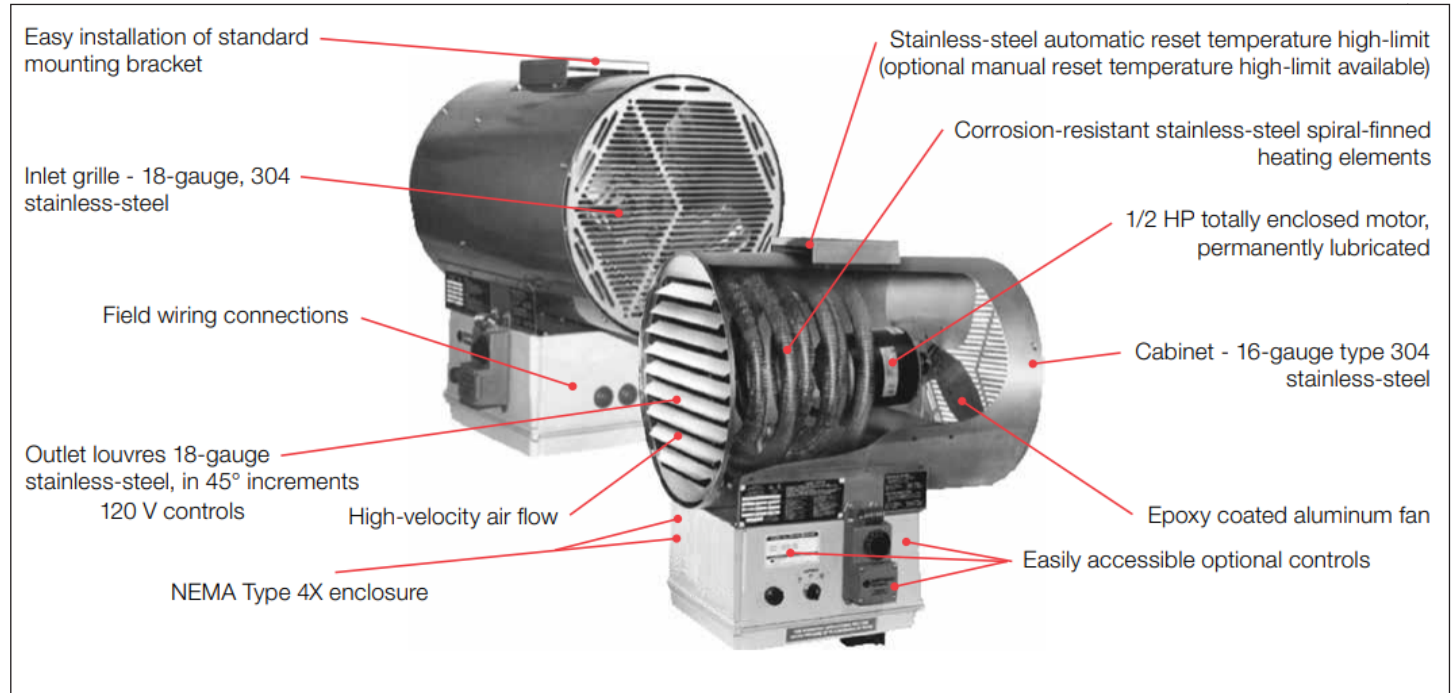

NEMA Type 4X rating for water penetration allows for increased safety and productivity.

Epoxy coated fan blades for added corrosion protection.

16-gauge stainless steel cabinet enables resistance to corrosion resulting in longer life.

Custom configured stainless steel elements enable improved heat distribution and corrosion protection.

Stainless steel wall/ceiling mount kit allow for greater mounting flexibility.

120V controls create better contractor pull-in reliability

Stainless steel temperature high-limit option available for increased safety and reliability

PERFORMANCE DATA - ALL MODELS



Table 7.1 - Unit Motor Data - All Models

Location & Air Delivery Type		Model	Heating Capacity				Air Data ①			
			High Stage		Low Stage		Airflow (CFM) ②	Temp Rise (°F)	Heat Throw (ft.)	Maximum Mounting Height (ft.) ④
			kW	Btu/hr	kW	Btu/hr				
Standard Locations	Horizontal Delivery	HER 30	3	10,200	n/a	n/a	380	25	12	8
		HER 50	5	17,100	n/a	n/a	380	42	12	8
		HER 75	7.5	25,600	n/a	n/a	530	45	14	8
		HER100	10	34,100	n/a	n/a	830	38	20	9
		HER125	12.5	42,700	n/a	n/a	830	48	20	10
		HER150	15	51,200	n/a	n/a	830	57	20	10
		HER200	20	68,200	n/a	n/a	1300	49	25	11
		HER250	25	85,300	n/a	n/a	1300 ④	61	25	12
		PTE300	30	102,400	15	51,200	2575	40	75	17
	PTE400	40	136,500	20	68,200	2575	54	60	15	
	PTE500	50	170,600	25	85,300	2575	70	45	14	
	Vertical Delivery	VE 50	5	17,100	n/a	n/a	800	21	See Table 7.3 for Throw/Mounting Height Data.	
		VE 75	7.5	25,600	n/a	n/a	800	31		
		VE 100	10	34,100	n/a	n/a	940	36		
		VE 150	15	51,200	n/a	n/a	1340	38		
		VE 200	19	64,800	n/a	n/a	1600	41		
		VE 250	25	85,300	n/a	n/a	1600	55		
VE 300		30	102,400	15	51,200	2575	40			
VE 400		40	136,500	20	68,200	2575	54			
Hazardous Locations (Explosion Proof) ③	Horizontal Delivery	HEX ___-3	3	10,250	n/a	n/a	500	19	15	7
		HEX ___-5	5	17,050	n/a	n/a	500	31.6	15	7
		HEX ___-7.5	7.5	25,600	n/a	n/a	850	27.9	30	10
		HEX ___-10	10	34,100	n/a	n/a	850	37.2	30	10
		HEX ___-15	15	51,200	n/a	n/a	1750	27.1	40	10
		HEX ___-20	20	68,250	n/a	n/a	1750	36.1	40	10
		HEX ___-25	25	85,300	n/a	n/a	3600	21.9	70	20
		HEX ___-30	30	102,350	n/a	n/a	3600	26.3	70	20
HEX ___-35	35	119,450	n/a	n/a	3950	28	70	20		
Washdown Electric Unit Heater	Horizontal Delivery	MEW ___-030	3	10,250	n/a	n/a	700	13.5	22	8.5
		MEW ___-050	5	17,050	n/a	n/a	700	22.5	22	8.5
		MEW ___-075	7.5	25,600	n/a	n/a	700	33.8	22	8.5
		MEW ___-100	10	34,100	n/a	n/a	700	45	22	8.5
		MEW ___-150	15	51,200	n/a	n/a	1450	32.6	35	11.5
		MEW ___-200	20	68,250	n/a	n/a	1450	43.6	22	11.5
		MEW ___-250	25	85,300	n/a	n/a	2100	37.5	44	12.3
		MEW ___-300	30	102,350	n/a	n/a	2100	45.1	44	12.3
		MEW ___-350	35	119,450	n/a	n/a	2100	52.6	44	12.3
		MEW ___-390	39	133,100	n/a	n/a	2100	58.6	44	12.3

- ① Airflow shown is at 70°F ambient and heating at full rated capacity.
- ② For HER, airflow CFM is for inlet. For PTE and VE, airflow CFM is outlet.
- ③ For HEX units above 6000 feet above sea level, altitude limits may exist. Refer to the latest revision of Installation & Service Manual 2-519.
- ④ MEW maximum mounting height for vertical orientation

Table 7.2 - Unit Motor Data - All Models

Model	Motor Information				
	Motor HP	Motor Type	Motor Bearing Type		
HER 30	1/40	Totally Enclosed, Shaded Pole	Sleeve		
HER 50					
HER 75					
HER 100	1/15				
HER 125					
HER 150					
HER 200					
HER 250					
PTE300	1/6			Totally Enclosed, Permanent Split Capacitor	Ball
PTE400					
PTE500					
VE 50	1/15	Totally Enclosed, Shaded Pole	Sleeve		
VE 75					
VE 100					
VE 150	1/8	Totally Enclosed, Permanent Split Capacitor	Ball		
VE 200					
VE 250	1/6				
VE 300					
VE 400					
VE 500					
HEX5_60-3.0	1/2			Explosion Proof	Ball
HEX5_60-5.0					
HEX5_60-7.5					
HEX5_60-10.0					
HEX5_60-15.0					
HEX5_60-20.0					
HEX5_60-25.0					
HEX5_60-30.0					
HEX5_60-35.0					
MEW__-030	1/2	Totally Enclosed, Permanently lubricated	Ball		
MEW__-050					
MEW__-075					
MEW__-100					
MEW__-150					
MEW__-200					
MEW__-250					
MEW__-300					
MEW__-350					
MEW__-390					

Performance Data

Heat Spread and Mounting Height

Refer to Table 7.1 and Figures 7.2 through 7.5 for the recommended mounting heights and accompanying heat spread of vertical units without an air deflector and with the three air deflectors offered.

Table 7.3 - Heat Spread and Mounting Height (Ft.) [Ⓢ]

Model No.	With No Deflector		With Deflector							
	Max. Height	Spread (S)	Truncone		Cone-Jet		Louvers			
			H	S	Vertical [Ⓢ]	Vertical [Ⓢ]	Vertical [Ⓢ]	Vertical [Ⓢ]	45° [Ⓢ]	45° [Ⓢ]
VE 50	13	20	9	24	18	23	15	13	8	23
VE 75	11	17	8	20	15	20	13	11	8	20
VE100	12	18	8	22	17	22	14	12	8	22
VE150	17	26	11	30	23	30	20	17	10	30
VE200	20	30	13	36	27	35	23	20	12	35
VE250	17	26	11	31	23	31	20	18	10	31
VE300	20	31	15	36	28	36	24	21	12	36
VE400	18	27	13	32	24	32	21	18	11	32
VE500	16	24	12	29	22	29	19	16	10	29

[Ⓢ] With 70°F ambient air and heating at full capacity

[Ⓢ] Indicates pitch of adjustable louvers. 45° louvers are available for one- or two-way deflection

Figure 7.3 - Vertical Air Outlet Accessories

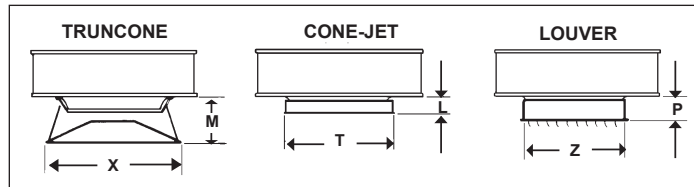

Table 7.4 - Vertical Air Outlet Accessories

Model No.	Truncone		Cone-Jet		Louvers	
	M	X	L	T	P	Z
VE50-VE250	12 1/2	22	6 1/2	18 7/8	6 1/2	16 7/8
VE300-VE-500	12 1/2	27	7 1/2	24 3/4	7 1/2	19 3/4

Figure 7.4 - Without Deflector

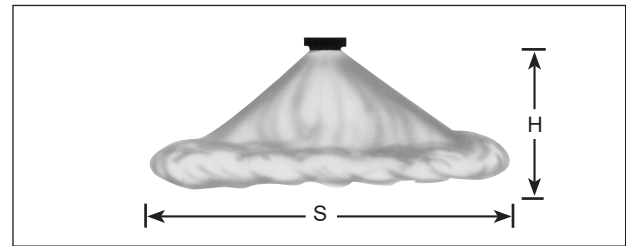

Figure 7.5 - With Truncone

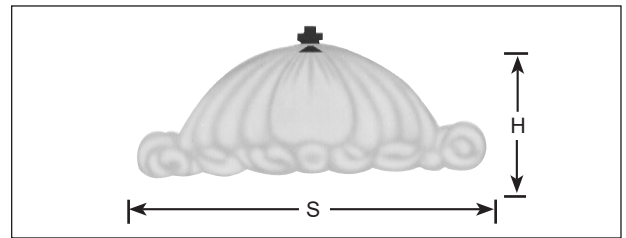

Figure 7.6 - With Cone-Jet

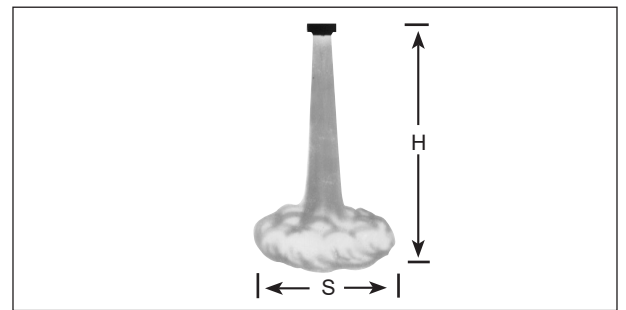

Figure 7.7 - With One- or Two-Way Louvers

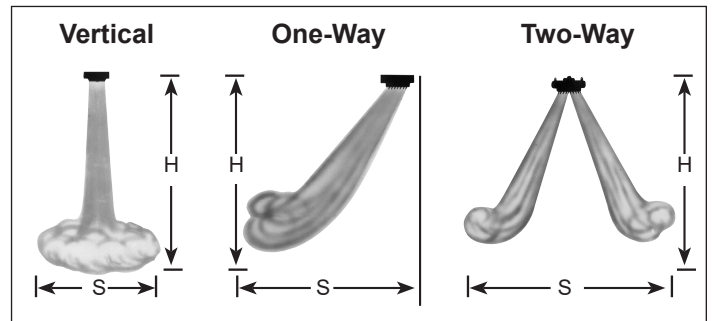
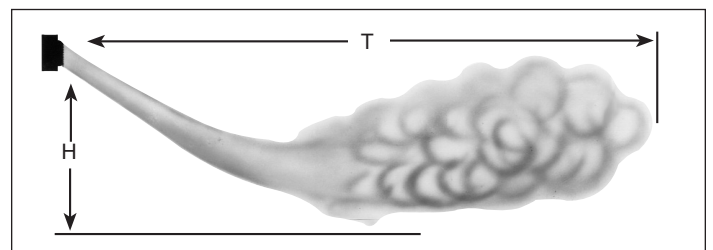

Figure 7.8 - Mounting Height & Heat Throw - Models HER, PTE, & HEX (refer to Table 6.1)



DIMENSIONAL DATA - ALL MODELS



Dimensional Data

Figure 8.1 - Model HER Dimensions (inches)

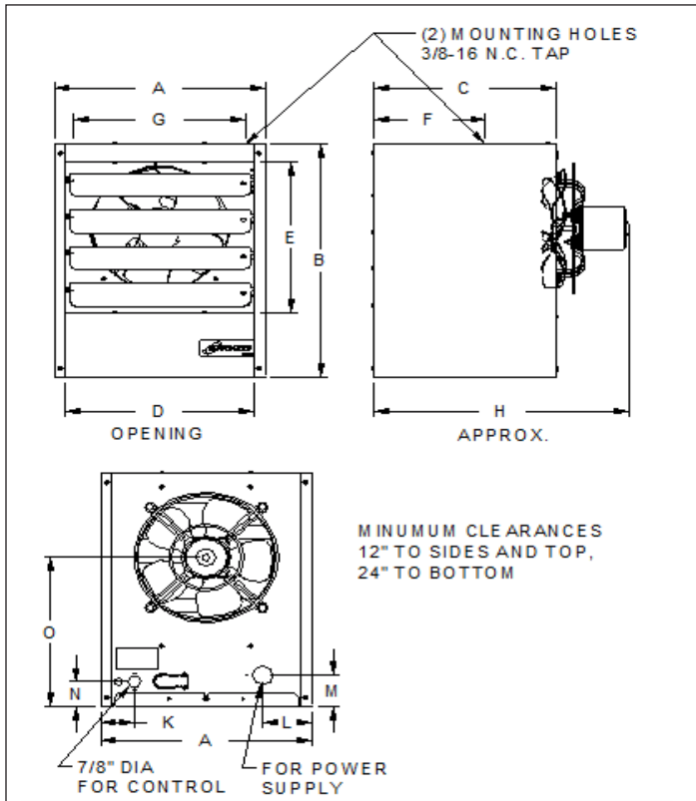

	MODEL							
Dim.	HER 30	HER 50	HER 75	HER 100	HER 125	HER 150	HER 200	HER 250
A	14-1/4	14-1/4	16-7/8	16-7/8	16-7/8	16-7/8	18-7/8	18-7/8
B	17-1/2	17-1/2	20-7/8	20-7/8	20-7/8	20-7/8	24	24
C	12-1/4	12-1/4	14-3/4	14-3/4	14-3/4	14-3/4	20	20
D	12-7/8	12-7/8	14-1/2	14-1/2	14-1/2	14-1/2	16-1/2	16-1/2
E	11-3/8	11-3/8	13	13	13	13	16	16
F	7-1/2	7-1/2	8-7/8	9-5/8	9-5/8	9-5/8	12-5/8	12-5/8
G	11-5/8	11-5/8	13-1/2	13-1/2	13-1/2	13-1/2	15-1/2	15-1/2
H	17-1/4	17-1/4	20-1/4	21-1/4	21-1/4	21-1/4	26-1/2	26-1/2
K	2-1/4	2-1/4	2-1/4	2-1/4	2-1/4	2-1/4	3-1/4	3-1/4
L	3-3/8	3-3/8	3-1/4	3-1/4	3-1/4	3-1/4	4-1/4	4-1/4
M	2-3/8	2-3/8	2-1/4	2-1/4	2-1/4	2-1/4	2-1/2	2-1/2
N	1-7/8	1-7/8	2-1/4	2-1/4	2-1/4	2-1/4	2-1/2	2-1/2
O	11-1/8	11-1/8	12-3/4	12-3/4	12-3/4	12-3/4	14-1/2	14-1/2
Fan Dia.	9	9	12	12	12	12	14	14
Wt. Lbs. ①	34 ①	34 ①	52 ①	67 ①	65 ①	74 ①	97 ①	98 ①

① Approximate Shipping Weight Add 7 lbs. for 480 and 600 Volt Models.

Figure 8.2 - Model PTE Dimensions (inches)

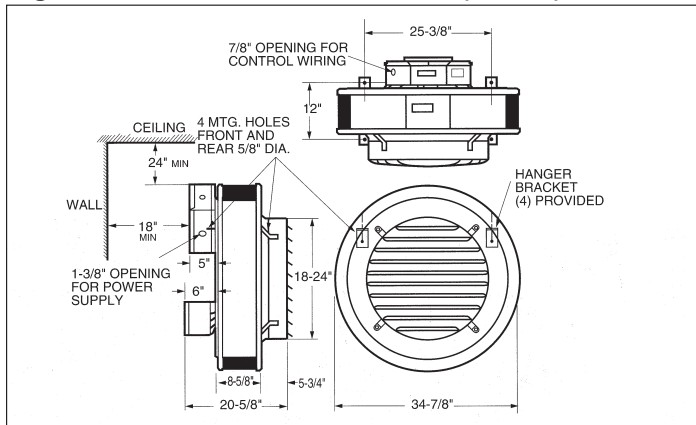
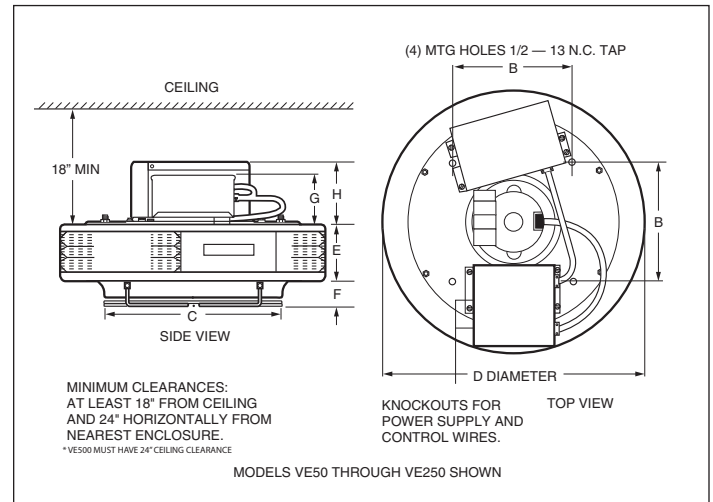

Figure 8.3 - Model VE Dimensions (inches)



	Model								
Dim.	VE50	VE75	VE100	VE150	VE200	VE250	VE300	VE400	VE500
B	11 3/8	11 3/8	11 3/8	11 3/8	11 3/8	11 3/8	18 3/8	18 3/8	18 3/8
C	14 1/2	14 1/2	14 1/2	14 1/2	14 1/2	14 1/2	19 1/2	19 1/2	19 1/2
D	24 7/8	24 7/8	24 7/8	24 7/8	24 7/8	24 7/8	34 7/8	34 7/8	34 7/8
E	4 1/4	4 1/4	5	5	5	5	8 5/8	8 5/8	8 5/8
F	4 3/4	4 3/4	4 3/4	4 3/4	4 3/4	4 3/4	2 1/8	2 1/8	2 1/8
G	4 3/4	4 3/4	4 3/4	4 3/4	4 3/4	4 3/4	4 3/4	4 3/4	4 3/4
H	6 1/4	6 1/4	6 1/4	6 1/4	6 1/4	6 1/4	6 1/4	6 1/4	6 1/4
Fan Dia.	14	14	14	14	14	14	19	19	19
Approx. Wt. Lbs.	62	64	66	70	72	73	122	125	129

Figure 8.4 - Model HEX Dimensions (inches)

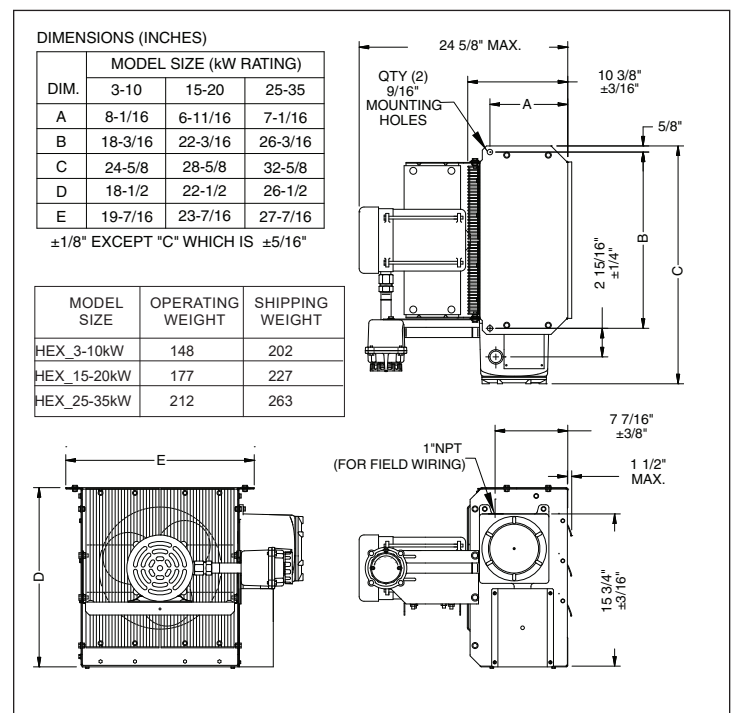
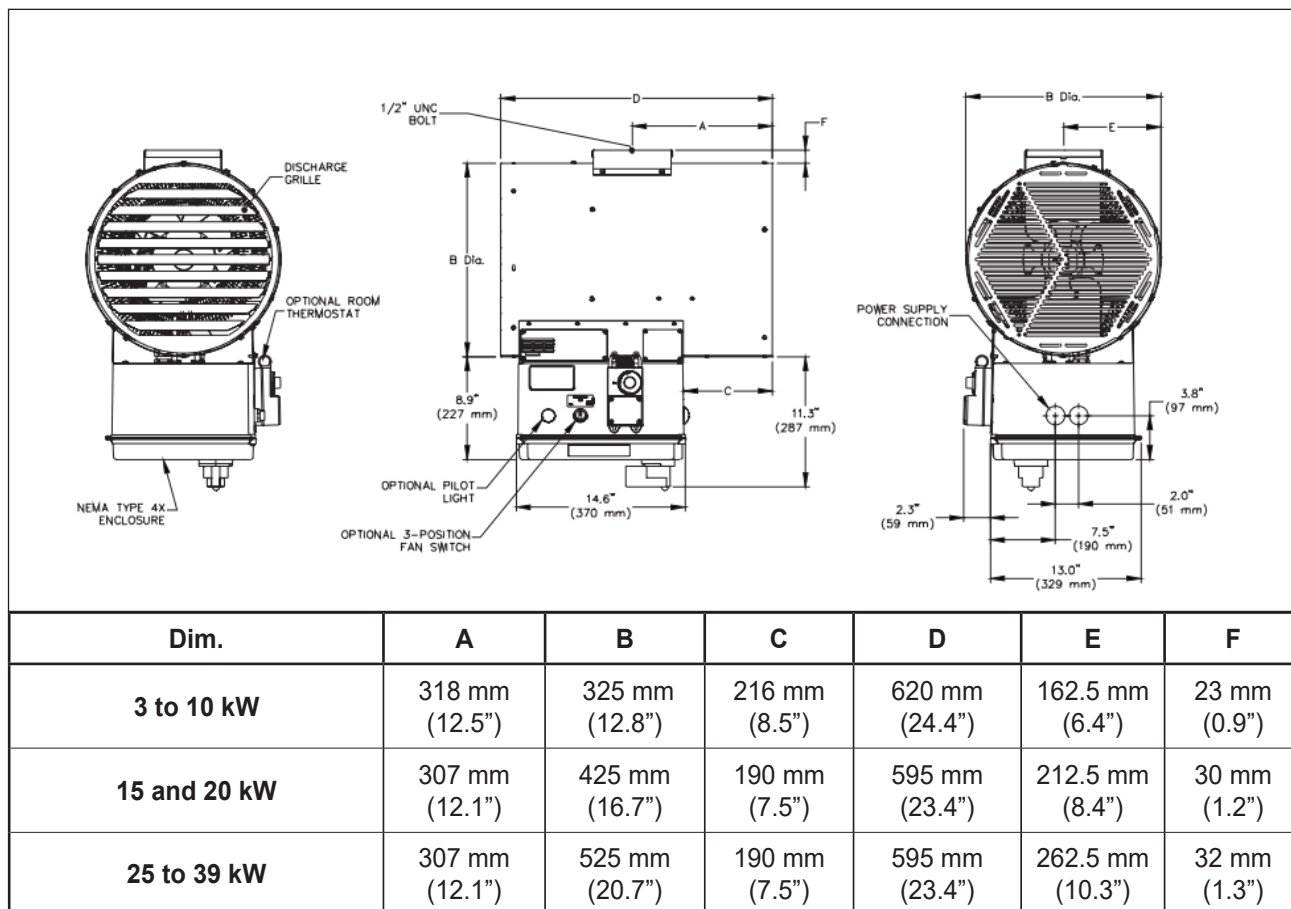

Figure 8.5 - Model MEW Dimensions



ACCESSORIES - FIELD INSTALLED

Thermostats

The unit-mounted thermostat in Figure 9.1 is provided as a field installed kit for a model HER series only. Temperature range of the dial setting is from 40°F to 90°F.

Other thermostats offered (not unit-mounted) are:

- Line-voltage single stage
- Line-voltage, 2-stage (available on PTE and VE models 300, 400 and 500)
- Low-voltage single stage (requires Low-Voltage Control kit.)

Figure 9.1 - Unit-Mounted Thermostat

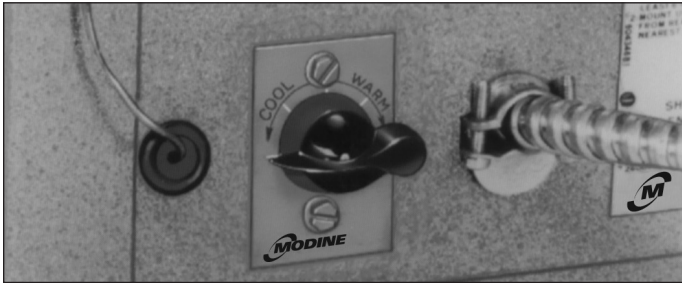

Low-Voltage Control

This control permits use of a low-voltage thermostat control of electric unit heaters. High capacity models VE300, VE400, VE500 and all PTE series heaters cannot operate in two stages with a low-voltage thermostat; however, they will respond in one stage with full operation of all elements. On model HER series, this control cannot be combined with the unit-mounted thermostat.

Summer-Winter Switch

In the winter position, the thermostat will cycle the fan and heating elements. In the summer position, the switch will permit the fan to run continuously while the heating elements are controlled by the thermostat. Maximum switch rating is 10A at 250 volts. Kit includes switch, conduit box, wire nuts, and installation instructions.

**Figure 9.2
Low-Voltage Control**

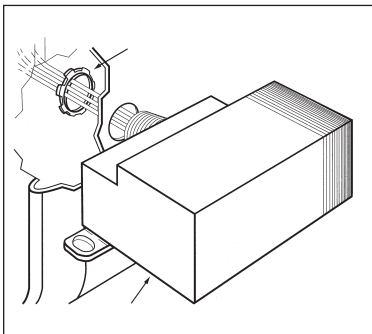

**Figure 9.3
Summer-Winter Switch**



Vertical Unit Air Deflector Blades

Blades used to deflect airflow in directions left or right of unit heater. Used in addition to standard horizontal deflector blades. Not available for Power-Throw™ models.

Vertical Unit Air Deflectors (refer to page 7 for more info)

- The cone-jet allows the discharge air stream to be adjusted from a concentrated high velocity jet to a broadened air stream to cover a larger area.
- The truncone causes a broad discharge air stream covering a larger area than possible with the cone-jet.
- The one-way louver allows the discharge air stream to be adjusted in one direction.
- The two-way louver allows the discharge air stream to be adjusted in two directions.

Pipe Suspension Adapter Kit

To facilitate threaded-pipe suspension mounting, a pipe-adapter kit is available that includes two drilled pipe caps and two 3/8 - 16 x 1 1/2" capscrews. One kit is required to pipe-mount HER series and two kits must be ordered to mount VE series unit heaters. This kit cannot be used with Power-Throw™ (PTE series) unit heaters.

Wall Mounting Bracket

For easier unit installation, where ceiling suspension is not feasible, a wall-mounting bracket is available for models HER50 through HER250 and PTE300 through PTE500. The one-point suspension illustrated in Figure 9.4 permits swiveling the unit 90° horizontally for most effective air flow direction. Fasteners for mounting to wall are not furnished.

**Figure 9.4
Wall Mounting Bracket**



Hanging Mounting Kit (HMK) ①
Simple and economical if adequate overhead structure exists. Requires 1/2" pipe, cut and threaded (not supplied)

Wall Mounting Kit (WMK) ①
Ideal for use in buildings that have substantial walls. the Z sections provide additional support where necessary.

Basic Mounting Kit (BMK) ①
Suitable for applications where the support arm can be bolted or welded directly to structural steel or concrete.

**Figure 9.5
HEX Mounting Kits ①**

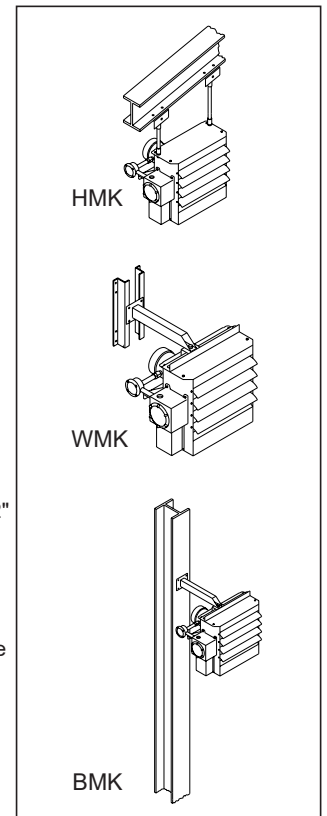

① Available for HEX models only.

Figure 9.5
MEW Wall Mounting Bracket

1. The heater must be permanently mounted with the control box at the bottom.
2. The mounting surface must be strong enough to:
 - a. Support the heater's weight.
 - b. Provide sufficient stiffness to prevent excessive vibration.
 - c. Withstand harsh situations such as transportable installations.
 - d. The single bolt mounting is not designed in contemplation of high dynamic loads that can occur during transportation. For heaters that are to be installed prior to transportation it is recommended that temporary blocking or strapping be used to limit movement of the heater with respect to the mounting structure. Inspection of the mounting bolt for correct tensioning is also recommended after arrival at site to ensure no loosening has occurred in transportation.
3. Install the heater at least 6 ft (1.8 m) from the floor.
4. Install the bracket (see Figure 2 - 5 for installation instructions).
 - a. Orient the heater to its final position before tightening all hardware.
 - b. In higher vibration installations use of a removable thread locking compound such as Loctite® 243 Blue Thread locker is recommended.
 - c. Correct tensioning of the mounting bolt will include full compression of the split lock washer and inspection for correct thread engagement. The mounting bolt/nut should be torqued to 65 - 75 ft-lbs.
 - d. Ensure that all safety pins are installed in the bolt(s) and clevis pin(s).
5. Louvered discharge grille can be rotated in 45° increments. Heater only complies with U.S. Coast Guard regulations when the grille is installed such that the airflow is directed downward.
6. For maximum tilt angles, see Figure 2. For maximum mounting height, see general specifications table on page 13.

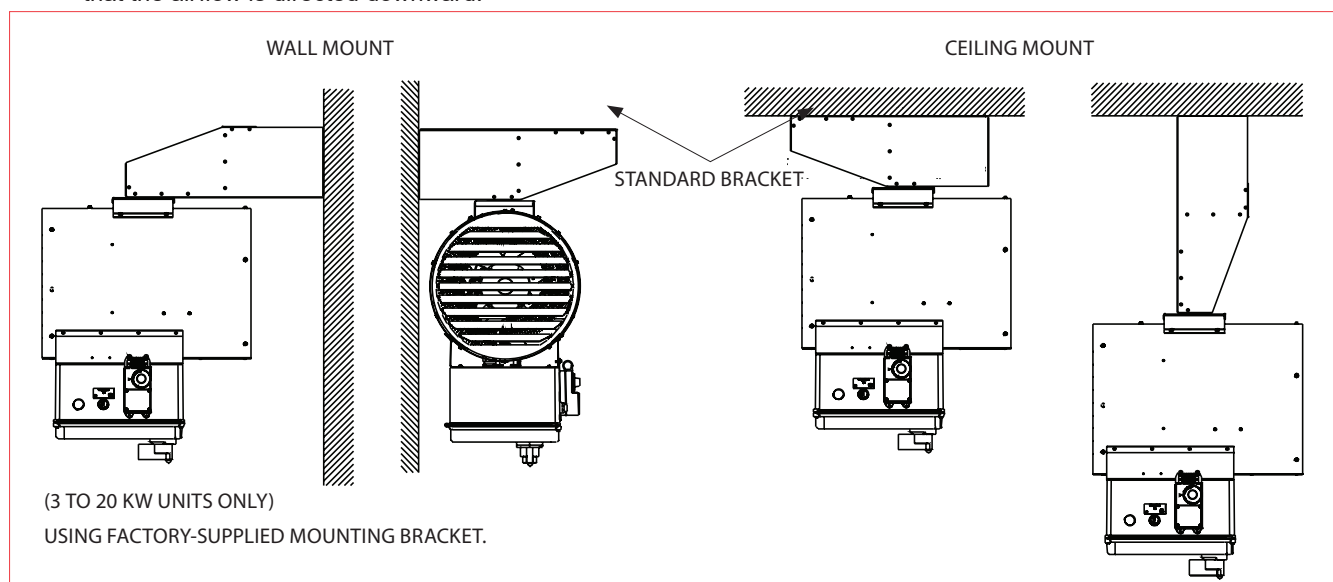
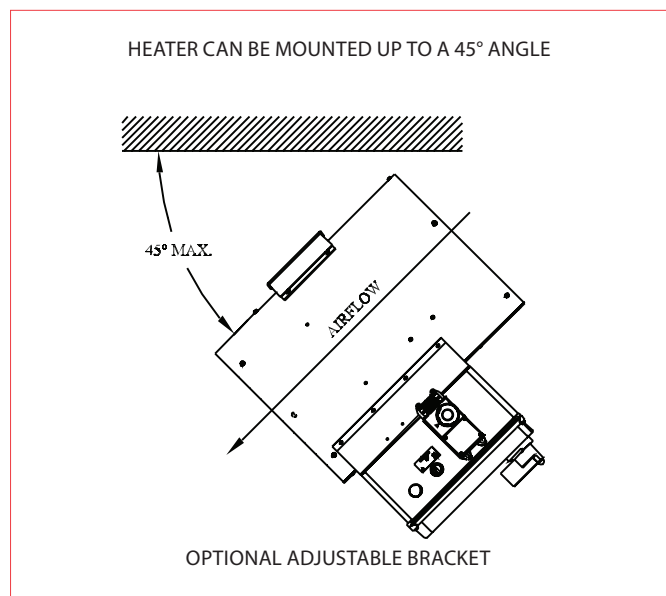

UNIT SELECTION - ALL MODELS



To order a Modine electric unit heater, specify:

1. Model Number:

- HER - Horizontal Electric Unit Heater
- VE - Vertical Electric Unit Heater
- PTE - Power-Throw™ Horizontal Electric Unit Heater
- HEX - Horizontal Explosion Proof Electric Unit Heater
- MEW - Washdown Electric Unit Heater

2. Select the full model number from Table 10.1 by locating the model series from Step 1 within Table 10.1 at the intersection of the kW rating and supply voltage required. If that selection shows "-", then there is not a model available matching those parameters.

3. Add any required accessories as shown on page 7 and 9.

Table 10.1 - Full Model Number Selection

		Supply Voltage and Power Code						
		208V/1ph	240V/1ph	208V/3ph	240V/3ph	V/3ph	600V/3ph	
Electric Unit Heater Type	kW Rating	11	12	31	32	33	34	
Standard Locations	Horizontal Air Delivery	3	HER 30C 1101	HER 30C 1201	HER 30C 3101	HER 30C 3201	HER 30C 3301	HER 30C 3401
		5	HER 50C 1101	HER 50C 1201	HER 50C 3101	HER 50C 3201	HER 50C 3301	HER 50C 3401
		7.5	HER 75C 1101	HER 75C 1201	HER 75C 3101	HER 75C 3201	HER 75C 3301	HER 75C 3401
		10	HER100C 1101	HER100C 1201	HER100C 3101	HER100C 3201	HER100C 3301	HER100C 3401
		12.5	-	-	HER125C 3101	HER125C 3201	HER125C 3301	HER125C 3401
		15	-	-	HER150C 3101	HER150C 3201	HER150C 3301	HER150C 3401
		20	-	-	HER200C 3101	HER200C 3201	HER200C 3301	HER200C 3401
		25	-	-	HER250C 3101	HER250C 3201	HER250C 3301	HER250C 3401
		30	-	-	-	-	PTE300C 3301	PTE300C 3401
		40	-	-	-	-	PTE400C 3301	PTE400C 3401
	50	-	-	-	-	PTE500C 3301	PTE500C 3401	
	Vertical Air Delivery	5	-	VE 50C 1201	VE 50C 3101	VE 50C 3201	VE 50C 3301	VE 50C 3401
		7.5	-	VE 75C 1201	VE 75C 3101	VE 75C 3201	VE 75C 3301	VE 75C 3401
		10	-	VE 100C 1201	VE 100C 3101	VE 100C 3201	VE 100C 3301	VE 100C 3401
		15	-	-	VE 150C 3101	VE 150C 3201	VE 150C 3301	VE 150C 3401
		20	-	-	-	VE 200C 3201	VE 200C 3301	VE 200C 3401
		25	-	-	-	-	VE 250C 3301	VE 250C 3401
		30	-	-	-	-	VE 300C 3301	VE 300C 3401
		40	-	-	-	-	VE 400C 3301	VE 400C 3401
		50	-	-	-	-	VE 500C 3301	VE 500C 3401
Hazardous Locations (Explosion Proof)		Horizontal Air Delivery	3	HEX5-208160-3.0	HEX5-240160-3.0	HEX5-208360-3.0	HEX5-240360-3.0	HEX5-360-3.0
	5		HEX5-208160-5.0	HEX5-240160-5.0	HEX5-208360-5.0	HEX5-240360-5.0	HEX5-360-5.0	-
	7.5		HEX5-208160-7.5	HEX5-240160-7.5	HEX5-208360-7.5	HEX5-240360-7.5	HEX5-360-7.5	--
	10		-	HEX5-240160-10.0	HEX5-208360-10.0	HEX5-240360-10.0	HEX5-360-10.0	-
	15		-	-	-	HEX5-240360-15.0	HEX5-360-15.0	-
	20		-	-	-	-	HEX5-360-20.0	-
	25		-	-	-	-	HEX5-360-25.0	-
	30		-	-	-	-	HEX5-360-30.0	-
	35		-	-	-	-	HEX5-360-35.0	-
Washdown Electric Unit Heater	Horizontal Air Delivery	3	MEW-208160-030	MEW-240160-030	MEW-208360-030	MEW-240360-030	MEW-480360-030	MEW-600360-030
		5	MEW-208160-050	MEW-240160-050	MEW-208360-050	MEW-240360-050	MEW-480360-050	MEW-600360-050
		7.5	MEW-208160-075	MEW-240160-075	MEW-208360-075	MEW-240360-075	MEW-480360-075	MEW-600360-075
		10	-	MEW-240160-100	MEW-208360-100	MEW-240360-100	MEW-480360-100	MEW-600360-100
		15	-	-	MEW-208360-150	MEW-240360-150	MEW-480360-150	MEW-600360-150
		20	-	-	-	-	MEW-480360-200	MEW-600360-200
		25	-	-	-	-	MEW-480360-250	MEW-600360-250
		30	-	-	-	-	MEW-480360-300	MEW-600360-300
		35	-	-	-	-	MEW-480360-350	MEW-600360-350
		39	-	-	-	-	MEW-480360-390	MEW-600360-390

A. Standards

- A.1.a. Units shall be UL and C-UL listed for safe operation, construction, and performance. Units shall be listed for use in both the U.S. and Canada for commercial and industrial installations. (Models HER, VE, and PTE)
- A.1.b. Explosion proof units, model HEX5 shall be UL listed and CSA certified for use in the following hazardous areas:
- Class I, Divisions 1 & 2, Groups C & D
 - Class II, Division 1, Groups E, F & G
 - Class II, Division 2, Groups F & G
 - Class I, Zones 1 & 2, Group IIA & IIB
- Units shall be rated for National Electrical Code and Canadian Electrical Code Temperature Code T3B 165°C (329°F).

B. Mechanical Configuration

- B.1.a. Heater shall be a Modine model HER horizontal air delivery electric unit heater of the size, capacity, and voltage as listed in the equipment schedule.
- B.1.b. Heater shall be a Modine Power-Throw™ model PTE horizontal air delivery electric unit heater of the size, capacity, and voltage as listed in the equipment schedule.
- B.1.c. Heater shall be a Modine model VE vertical air delivery electric unit heater of the size, capacity, and voltage as listed in the equipment schedule.
- B.1.d. Heater shall be a Modine model HEX5 horizontal air delivery electric unit heater of the size, capacity, and voltage as listed in the equipment schedule.

C. Unit Casing

- C.1. Unit shall have a steel casing that is treated for corrosion resistance and painted with an electrostatically applied, baked on, gray-green polyester powdercoat paint finish. (Models HER, VE, and PTE)
- C.2.a. Model HER unit shall have a squared corner casing and the top shall have two threaded holes (3/8" - 16 TAP) for threaded rod suspension. The bottom of casing shall have a hinged panel for service access to wiring and controls.
- C.2.b. Model PTE unit shall consist of two circular steel covers bolted together with the heating element supports. The air discharge side cover shall have a die-formed fan venturi. The back cover shall have a depression for motor mounting with openings for cooling-air circulation for the motor. Four hanging brackets shall be provided for use with 5/8" diameter suspension rods.
- C.2.c. Model VE unit shall consist of two circular steel covers bolted together with the heating element supports. The bottom cover shall have a die-formed fan venturi. The top cover shall include an inner cone for motor mounting and to provide a heat shield from radiant and convective heat from the heating elements.
- C.2.d. Model HEX5 shall be fabricated from 14 gauge steel with a baked epoxy powder coating over a 5-stage pretreatment including iron phosphate, for protection from corrosive atmospheres. The cabinet shall include two (2) 9/16" mounting holes located on the top.

D. Heating Elements

- D.1.a. Elements shall consist of a nickel-chromium resistance wire surrounded with magnesium oxide and sheathed in steel spiral-finned tubes. Elements shall have kilowatt rating as listed in the equipment schedule. (Models HER, VE, and PTE)
- D.1.b. The heat exchanger shall be fluid-to-air type consisting of steel tubes with roll-formed aluminum fins and be vacuum charged. The heat exchanger shall be protected by a preset 100 psig (690 kPa) pressure-relief valve, aluminum body, no serviceable parts. The heat exchanger shall be filled to design level with a custom-

blended, long-life solution of ethylene-glycol, water, and corrosion inhibitors. The heat exchanger shall have three heavy-duty immersion heating elements brazed into a heavy steel bulkhead. The elements shall consist of high-quality resistance wire embedded in a compacted magnesium oxide refractory and sheathed in metal tubing. The heater is to be protected by a snap-action bimetal temperature high-limit, which shall not be affected by altitude or changes in atmospheric pressure. The high-limit shall be an automatic reset type, and will shut off the heater if the exchanger temperature rises due to a lack of heat dissipation.

E. Motor and Propeller Fan

- E.1.a. Each unit shall have a single 208-230V/60Hz/1ph motor. The motor shall be totally enclosed, continuous-duty, with automatic resetting, thermal-overload protection. Propeller fan shall be directly connected to the motor shaft and be statically balanced. The motor shall be mounted to the unit with rubber vibration absorbing material. (Models HER, VE, and PTE)
- E.1.b. Each unit shall have a ball bearing, permanently lubricated, thermally protected explosion-proof motor rated for continuous duty. The fan blades shall be aluminum to prevent sparking. Propeller fan shall be directly connected to the motor shaft and be statically balanced. The fan shall be shielded with a heavy-duty epoxy coated guard of two piece construction to provide easy maintenance and cleaning of the fan and motor. The guard shall not allow a 1/4" or larger probe to enter. (Model HEX5 only)

F. Electrical

- F.1. All units shall have built-in contactors and control circuit transformers (where required) to provide single-source power connection.
- F.1.a. Models VE and PTE, sizes 300 through 500 shall have two sets of contactors to provide for two-stage operation.
- F.1.b. Model HEX5 shall have a contactor coil that is encapsulated severe duty and separately fuse-protected.
- F.2. Fuse blocks and factory-supplied fuses shall be installed on all models except HER 30, 50, and 75 with 208 volt or 230-volt single or 3-phase power supply. A wiring diagram and grounding lug shall be included in each control compartment.
- F.3.a. Transformers shall be factory installed on all models with 460 and 600 volt, 3 phase power supply to permit 230 volt motor operation. (Models HER, VE, and PTE)
- F.3.b. Transformers shall be factory installed on all HEX5 models with the primary voltage being the same as the heater voltage and the secondary being 120V grounded circuit.
- F.4. Electrical control components shall be safely enclosed in a separate junction box. A wiring diagram and a grounding lug shall be included in each power junction box.
- F.4.a. The Model HEX5 control center shall be enclosed in an explosion-proof control enclosure with a large threaded cover for easy access. The control center shall include a printed circuit board with a terminal block for room thermostat connection and in-line fuse protection, with both an operating fuse and a spare fuse.
- F.5. (opt) The HEX5 heater shall be supplied with a built-in explosion-proof room thermostat mounted on the control enclosure side of the heater.

G. Air Deflectors

- G.1.a. Adjustable horizontal air deflectors shall be furnished. (Models HER and PTE)
- G.1.b. Louvers shall be individually adjustable and made of anodized extruded aluminum. (Model HEX5)

Products from Modine are designed to provide indoor air-comfort and ventilation solutions for residential, commercial, institutional and industrial applications. Whatever your heating, ventilating and air conditioning requirements, Modine has the product to satisfy your needs, including:

HVAC

- Unit Heaters:
 - Gas
 - Hydronic
 - Electric
 - Oil
- Ceiling Cassettes
- Duct Furnaces
- Hydronic Cabinet Unit Heaters, Convectors
- Infrared Heaters
 - Gas
 - Electric
- Make-up Air Systems
- Unit Ventilators

Ventilation

- Packaged Rooftop Ventilation

School Products

- Vertical Packaged Classroom HVAC:
 - DX Cooling/Heat Pump
 - Horizontal/Vertical Unit Ventilators

Specific catalogs are available for each product. Catalogs 75-136 and 75-137 provide details on all Modine HVAC equipment.



Modine Manufacturing Company

1500 DeKoven Avenue

Racine, Wisconsin 53403-2552

Phone: 1.800.828.4328 (HEAT)

www.modinevac.com

© Modine Manufacturing Company 2023