



**2-528**

August 2023

# INSTALLATION AND SERVICE MANUAL

## Overhead Electric Infrared Heaters

### Models MEL

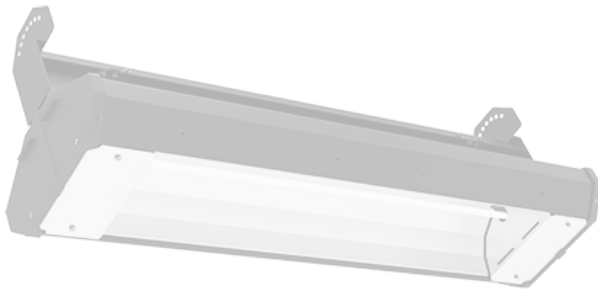

#### INSTRUCTIONS APPLY TO:

- Installation  Operation  Maintenance

#### **▲ WARNING ▲**

Improper installation, adjustment, alteration, service or maintenance can cause property damage, injury or death. Read the installation, operating, and service/ maintenance instructions thoroughly before installing or servicing this equipment.

#### **▲ WARNING ▲**

Outdoor residential use only. Installation of this infrared heater system in residential indoor spaces, RVs, mobile homes, etc. may result in property damage, fire, serious injury, or death.

#### **FOR YOUR SAFETY**

The use and storage of gasoline or other flammable vapors and liquids in the vicinity of this appliance is hazardous.

#### **Inspection on Arrival**

1. Inspect unit upon arrival. In case of damage, report it immediately to transportation company and your local Modine sales representative.
2. Check rating plate on unit to verify that power supply and motor specification requirements meet available electric power at the point of installation.
3. Inspect unit upon arrival for conformance with description of product ordered (including specifications where applicable).

#### **IMPORTANT**

The use of this manual is specifically intended for a qualified installation and service agency. A qualified installation and service agency must perform all installation and service of these appliances.

#### **HAZARD INTENSITY LEVELS**

- **DANGER:** Failure to comply will result in severe personal injury or death and property damage
- **WARNING:** Failure to comply could result in severe personal injury or death and/or property damage.
- **CAUTION:** Failure to comply could result in minor personal injury and/or property damage.

#### **CONTENTS**

Section	Page
1. Safety .....	3
2. Installation .....	11
3. Maintenance .....	18
4. Parts List .....	20
5. Limited Warranty.....	23

#### **These heaters must NOT be used in the following applications:**

- Enclosed swimming pool areas
- Areas with contaminated atmospheres.
- Areas requiring explosion-proof equipment.
- Process heating applications.

#### **ATTENTION**

Mount a copy of these instructions adjacent to the heater and retain a copy for future reference.

# Contents

**1.0 Safety** ..... **3**

    Safety Symbols..... 3

    Applications ..... 3

    Model Number Designation Chart ..... 4

    Available Models and Specifications ..... 4

    Clearances to Combustibles ..... 7

    Safety Labels and Their Locations ..... 9

    Standards, Certifications, and Government Regulations..... 10

**2.0 Installation** ..... **11**

    Design ..... 11

    Heater Mounting ..... 13

    Lamp Installation ..... 15

    Outdoor Application..... 16

    Electrical Wiring..... 16

**3.0 Maintenance** ..... **18**

    Troubleshooting Guide ..... 19

    Heater Assembly Components ..... 20

    Parts List..... 21

**4.0 Limited Warranty**..... **23**

## **WARNING**

### **California Proposition 65**

This product can expose you to chemicals including lead, which is known to the State of California to cause birth defects or other reproductive harm.

For more information, go to [www.P65Warnings.ca.gov](http://www.P65Warnings.ca.gov).

# 1.0 Safety

## ⚠ WARNING



Improper installation, adjustment, alteration, service, or maintenance can cause property damage, serious injury, or death. Read and understand the installation, operating, and maintenance instructions thoroughly before installing or servicing this equipment. Only trained, qualified personnel with proper electrical experience may install or service this equipment.

### Safety Symbols

Safety is the most important consideration during installation, operation, and maintenance of the infrared heater. You will see the following symbols and signal words when there is a hazard related to safety or property damage.

#### ⚠ WARNING

**Warning** indicates a potentially hazardous situation which, if not avoided, could result in death or injury.

#### ⚠ CAUTION

**Caution** indicates a potentially hazardous situation which, if not avoided, could result in minor or moderate injury.

#### NOTICE

**Notice** indicates a potentially hazardous situation which, if not avoided, could result in property damage.

### Applications

This is not an explosion proof heater. No MEL series heater may be used in a Class 1 or Class 2 Explosive Environment. Consult your local fire marshal, insurance carrier, and other authorities for approval if the proposed installation is in question.

#### Commercial / Industrial (Indoors & Outdoors)

Infrared heaters are designed and certified for use in industrial and commercial buildings such as warehouses, manufacturing plants, aircraft hangars, and vehicle maintenance shops. For maximum safety, the building must be evaluated for potential hazards before installing the heater system. A critical safety factor to consider before installation is the clearances to combustibles.

#### Outdoor Residential Only

This heater is **NOT** approved for use in an indoor residential application. This includes, but is not limited to, attached garages, living quarters, solariums, etc. Consult the local fire marshal and/or insurance provider if unsure of your application.

## ⚠ WARNING



#### Not For Residential Use.

Installation of this infrared heater system in residential indoor spaces, RVs, mobile homes, etc. may result in property damage, fire, serious injury, or death.

Chart 1.1 • Model Number Designation Chart

Series	Material Type	Lamp Quantity	Voltage	
MEL-24	B = Black Powder Coat with Black Nylon End Caps	1	120	277
MEL-33		2	208	480
MEL-46		3	240	575

Model Configuration Examples: MEL-24B1-120

Chart 1.2 • Available Models and Specifications - 24"

Series	Lamp Type	Voltage*	Total Amps	Total Watts	BTU/h
MEL-24B1-120	H.O. Medium Wave	120 V	11.30	1,360	4,641
MEL-24B1-208	H.O. Medium Wave	208 V	6.53	1,360	4,641
MEL-24B1-240	H.O. Medium Wave	240 V	5.66	1,360	4,641
MEL-24B1-277	H.O. Medium Wave	277 V	4.90	1,360	4,641
MEL-24B1-480	H.O. Medium Wave	480 V	2.83	1,360	4,641
MEL-24B2-120	H.O. Medium Wave	120 V	22.60	2,720	9,281
MEL-24B2-208	H.O. Medium Wave	208 V	13.06	2,720	9,281
MEL-24B2-240	H.O. Medium Wave	240 V	11.32	2,720	9,281
MEL-24B2-277	H.O. Medium Wave	277 V	9.80	2,720	9,281
MEL-24B2-480	H.O. Medium Wave	480 V	5.66	2,720	9,281
MEL-24B3-208	H.O. Medium Wave	208 V	19.59	4,080	13,922
MEL-24B3-240	H.O. Medium Wave	240 V	16.98	4,080	13,922
MEL-24B3-277	H.O. Medium Wave	277 V	14.70	4,080	13,922
MEL-24B3-480	H.O. Medium Wave	480 V	8.49	4,080	13,922

Chart 1.3 • Available Models and Specifications - 33"

Series	Lamp Type	Voltage*	Total Amps	Total Watts	BTU/h
MEL-33B1-208	H.O. Medium Wave	208 V	10.20	2,125	7,251
MEL-33B1-240	H.O. Medium Wave	240 V	8.85	2,125	7,251
MEL-33B1-277	H.O. Medium Wave	277 V	7.67	2,125	7,251
MEL-33B1-480	H.O. Medium Wave	480 V	4.42	2,125	7,251
MEL-33B2-208	H.O. Medium Wave	208 V	20.40	4,250	14,502
MEL-33B2-240	H.O. Medium Wave	240 V	17.70	4,250	14,502
MEL-33B2-277	H.O. Medium Wave	277 V	15.34	4,250	14,502
MEL-33B2-480	H.O. Medium Wave	480 V	8.84	4,250	14,502
MEL-33B3-277	H.O. Medium Wave	277 V	23.01	6,375	21,752
MEL-33B3-480	H.O. Medium Wave	480 V	13.26	6,375	21,752

\* Heaters are configured at the factory for single phase wiring. If three phase service is desired, it must be wired as such in the field by a trained installer / electrical contractor.

Chart 1.4 • Available Models and Specifications - 46"

Series	Lamp Type	Voltage*	Total Amps	Total Watts	BTU/h
MEL-46B1-277	H.O. Medium Wave	277 V	11.55	3,200	10,919
MEL-46B1-480	H.O. Medium Wave	480 V	6.66	3,200	10,919
MEL-46B1-575	H.O. Medium Wave	575 V	5.56	3,200	10,919
MEL-46B2-277	H.O. Medium Wave	277 V	23.10	6,400	21,838
MEL-46B2-480	H.O. Medium Wave	480 V	13.32	6,400	21,838
MEL-46B2-575	H.O. Medium Wave	575 V	11.12	6,400	21,838
MEL-46B3-480	H.O. Medium Wave	480 V	19.98	9,600	32,757
MEL-46B3-575	H.O. Medium Wave	575 V	16.68	9,600	32,757

\* Heaters are configured at the factory for single phase wiring. If three phase service is desired, it must be wired as such in the field by a trained installer / electrical contractor.

## Clearances to Combustibles

### ⚠ WARNING



Placement of explosive objects, flammable objects, liquids, and vapors close to the heater may result in explosion, fire, property damage, serious injury, or death. Do not store or use explosive objects, liquids, or vapors in the vicinity of the heater.

Failure to comply with the published clearances to combustibles could result in personal injury, death, and/or property damage.

The outside surfaces of the heater are hot during operation and after operation. If contact is made, permanent skin damage may occur. Do not move, handle, or service the unit during operation or while hot.

### ⚠ CAUTION



Signs shall be posted specifying the maximum permissible stacking height in order to maintain clearances to combustibles.

#### Hazards Include:

For maximum safety the building must be evaluated for hazards before installing the heater system. Examples include, but are not limited to:

- Gas and electrical lines
- Combustible and explosive materials
- Chemical storage areas
- Areas of high chemical fume concentrations
- Provisions for accessibility to the heater
- Adequate clearances around air openings
- Vehicle parking areas
- Vehicles with lifts or cranes
- Storage areas with stacked materials
- Lights
- Sprinkler heads
- Overhead doors and tracks
- Dirty, contaminated environment

A critical safety factor to consider before installation is the clearances to combustibles. **Clearance to combustibles** is defined as *the minimum distance you must have between the indicated surface and the combustible item*. Considerations must also be made for moving objects around the infrared heater. The following is a partial list of items to maintain clearances from:

#### Combustible Items Include:

- Wood
- Paper
- Fabric
- Chemicals
- Wall or roof insulation
- Plastics

#### Moving Objects Include:

- Overhead doors
- Vehicles on lifts
- Cranes
- Hoists

When installing the infrared heater system, the minimum clearances to combustibles must be maintained. These distances are shown in Chart 1.5 and on the heater. If you are unsure of the potential hazards, consult your local fire marshal, fire insurance carrier, or other qualified authorities on the installation of infrared heaters for approval of the proposed installation.

Chart 1.5 • Clearances to Combustibles in Inches (Millimeters) - see Figure 1.1

Length	Mounting Angle	Side		End	Top	Below	Min. Mtg. Height	
		Front	Behind				US	Canada
<b>Single Element</b>								
24" 33" 46"	0°	16 (407)	16 (407)	12 (305)	6 (153)	56 (1423)	6 ft.	2.4 m
	45°	47 (1194)	4 (102)	12 (305)	10 (254)	40 (1016)		
<b>Double Element</b>								
24" 33" 46"	0°	28 (712)	28 (712)	26 (661)	6 (153)	86 (2185)	7.5 ft.	2.4 m
	45°	86 (2185)	4 (102)	26 (661)	10 (254)	86 (2185)		
<b>Triple Element</b>								
24" 33" 46"	0°	31 (788)	31 (788)	34 (864)	9 (229)	105 (2667)	9 ft.	2.8 m
	45°	105 (2667)	4 (102)	34 (864)	10 (254)	105 (2667)		

\* Heaters mounted on an angle between 0° and 45° must maintain clearances posted for 0° or 45°, whichever is greater.

\*\* Clearances to combustibles must be maintained when using recessed mount kits (P/N: ELx-FRxx). For additional information, refer to form # LSH123a - Recessed Mounting Frame Installation Instructions or contact the factory.

**NOTE:** Ensure that building materials with a low heat tolerance (i.e, awnings, fabrics, plastics, sprinklers, insulation, etc.) are protected against degradation. This may require the heater to be mounted at a distance in excess of the published clearances to combustibles. Contact the material manufacturer for specific details.

Figure 1.1 • Clearances to Combustibles

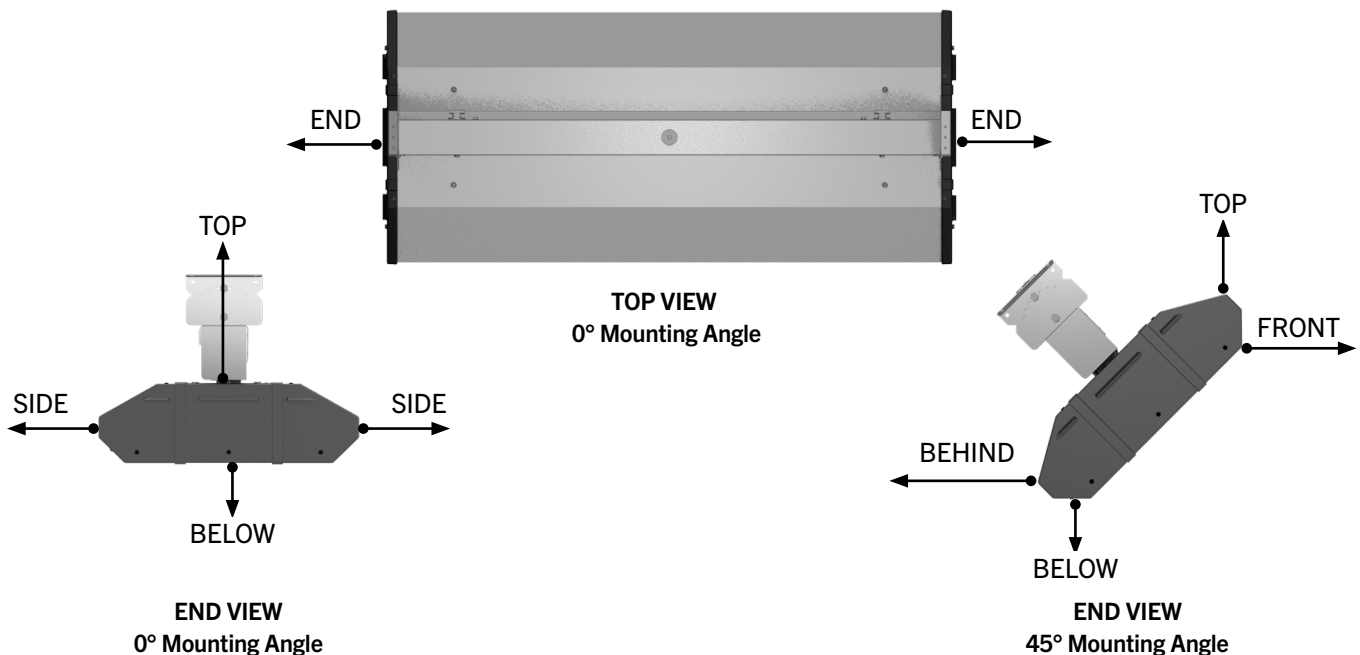



# Safety Labels and Their Locations

It is important to provide warnings to alert individuals to potential hazards and safety actions. Signs should state the hazards for the particular application and be legible to the building occupants. Consult the factory or a factory representative for additional information on signage compliance.

Safety warning labels must be maintained on the infrared heater. Illustrations of the safety labels and their locations are pictured below. When no longer legible, they must be replaced. Contact either your local distributor or the product manufacturer for obtaining replacement signs or labels.

## Top View

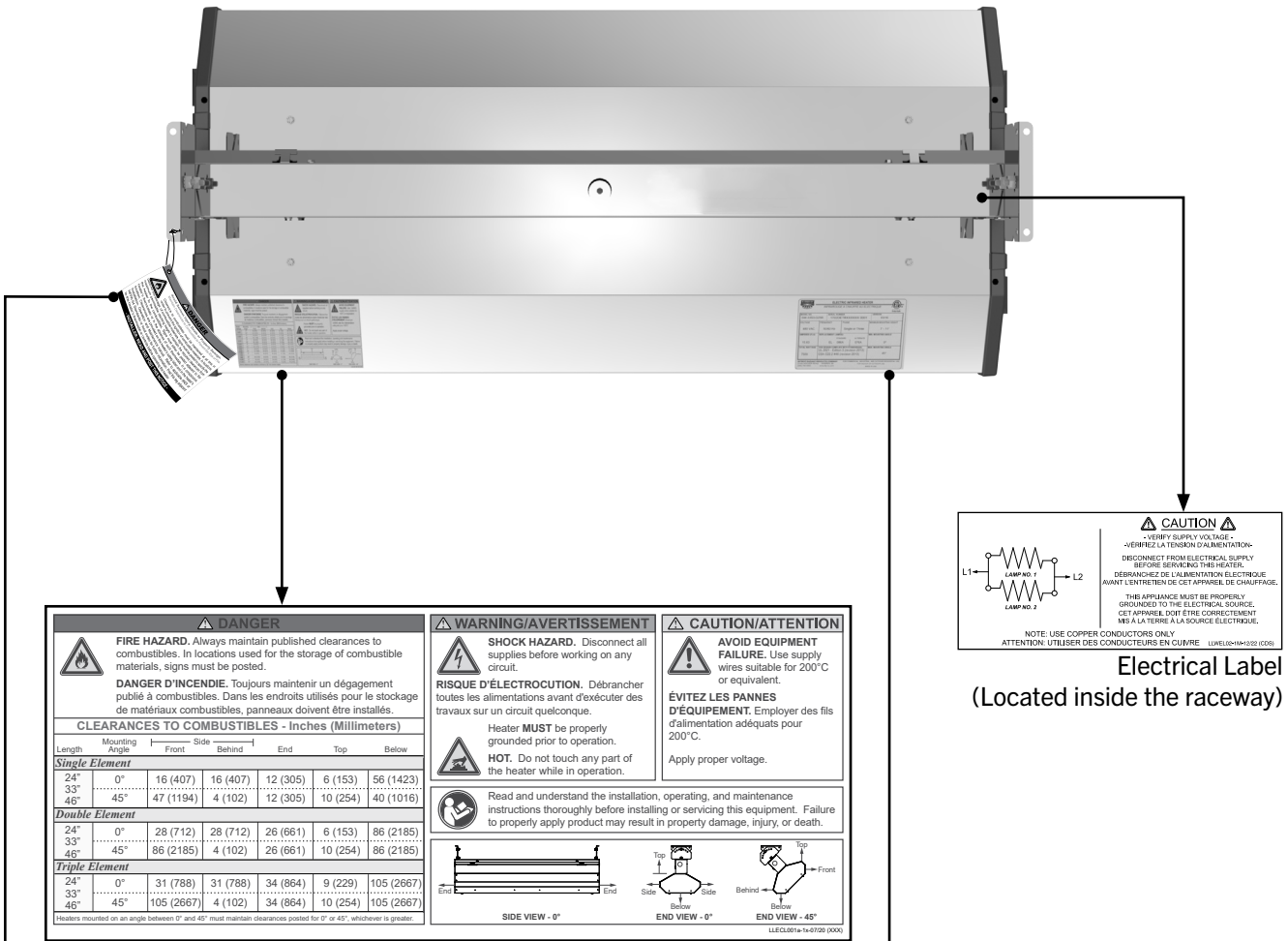

DANGER		WARNING/AVERTISSEMENT		CAUTION/ATTENTION																																																																																														
<p><b>FIRE HAZARD.</b> Always maintain published clearances to combustibles. In locations used for the storage of combustible materials, signs must be posted.</p> <p><b>DANGER D'INCENDIE.</b> Toujours maintenir un dégagement publié à combustibles. Dans les endroits utilisés pour le stockage de matériaux combustibles, panneaux doivent être installés.</p>		<p><b>SHOCK HAZARD.</b> Disconnect all supplies before working on any circuit.</p> <p><b>RISQUE D'ÉLECTROCUTION.</b> Débrancher toutes les alimentations avant d'exécuter des travaux sur un circuit quelconque.</p>		<p><b>AVOID EQUIPMENT FAILURE.</b> Use supply wires suitable for 200°C or equivalent.</p> <p><b>ÉVITEZ LES PANNES D'ÉQUIPEMENT.</b> Adoptez des fils d'alimentation adéquats pour 200°C.</p>																																																																																														
<p><b>CLEARANCES TO COMBUSTIBLES - Inches (Millimeters)</b></p> <table border="1"> <thead> <tr> <th rowspan="2">Length</th> <th rowspan="2">Mounting Angle</th> <th colspan="2">Side</th> <th rowspan="2">End</th> <th rowspan="2">Top</th> <th rowspan="2">Below</th> </tr> <tr> <th>Front</th> <th>Behind</th> </tr> </thead> <tbody> <tr> <td colspan="7"><b>Single Element</b></td> </tr> <tr> <td>24"</td> <td>0°</td> <td>16 (407)</td> <td>16 (407)</td> <td>12 (305)</td> <td>6 (153)</td> <td>56 (1423)</td> </tr> <tr> <td>33"</td> <td>45°</td> <td>47 (1194)</td> <td>4 (102)</td> <td>12 (305)</td> <td>10 (254)</td> <td>40 (1016)</td> </tr> <tr> <td>46"</td> <td>45°</td> <td>86 (2185)</td> <td>4 (102)</td> <td>26 (661)</td> <td>10 (254)</td> <td>86 (2185)</td> </tr> <tr> <td colspan="7"><b>Double Element</b></td> </tr> <tr> <td>24"</td> <td>0°</td> <td>28 (712)</td> <td>28 (712)</td> <td>26 (661)</td> <td>6 (153)</td> <td>86 (2185)</td> </tr> <tr> <td>33"</td> <td>45°</td> <td>86 (2185)</td> <td>4 (102)</td> <td>26 (661)</td> <td>10 (254)</td> <td>86 (2185)</td> </tr> <tr> <td>46"</td> <td>45°</td> <td>105 (2667)</td> <td>4 (102)</td> <td>34 (864)</td> <td>9 (229)</td> <td>105 (2667)</td> </tr> <tr> <td colspan="7"><b>Triple Element</b></td> </tr> <tr> <td>24"</td> <td>0°</td> <td>31 (788)</td> <td>31 (788)</td> <td>34 (864)</td> <td>9 (229)</td> <td>105 (2667)</td> </tr> <tr> <td>33"</td> <td>45°</td> <td>105 (2667)</td> <td>4 (102)</td> <td>34 (864)</td> <td>10 (254)</td> <td>105 (2667)</td> </tr> <tr> <td>46"</td> <td>45°</td> <td>105 (2667)</td> <td>4 (102)</td> <td>34 (864)</td> <td>10 (254)</td> <td>105 (2667)</td> </tr> </tbody> </table> <p>Heaters mounted on an angle between 0° and 45° must maintain clearances posted for 0° or 45°, whichever is greater.</p>						Length	Mounting Angle	Side		End	Top	Below	Front	Behind	<b>Single Element</b>							24"	0°	16 (407)	16 (407)	12 (305)	6 (153)	56 (1423)	33"	45°	47 (1194)	4 (102)	12 (305)	10 (254)	40 (1016)	46"	45°	86 (2185)	4 (102)	26 (661)	10 (254)	86 (2185)	<b>Double Element</b>							24"	0°	28 (712)	28 (712)	26 (661)	6 (153)	86 (2185)	33"	45°	86 (2185)	4 (102)	26 (661)	10 (254)	86 (2185)	46"	45°	105 (2667)	4 (102)	34 (864)	9 (229)	105 (2667)	<b>Triple Element</b>							24"	0°	31 (788)	31 (788)	34 (864)	9 (229)	105 (2667)	33"	45°	105 (2667)	4 (102)	34 (864)	10 (254)	105 (2667)	46"	45°	105 (2667)	4 (102)	34 (864)	10 (254)	105 (2667)
Length	Mounting Angle	Side		End	Top			Below																																																																																										
		Front	Behind																																																																																															
<b>Single Element</b>																																																																																																		
24"	0°	16 (407)	16 (407)	12 (305)	6 (153)	56 (1423)																																																																																												
33"	45°	47 (1194)	4 (102)	12 (305)	10 (254)	40 (1016)																																																																																												
46"	45°	86 (2185)	4 (102)	26 (661)	10 (254)	86 (2185)																																																																																												
<b>Double Element</b>																																																																																																		
24"	0°	28 (712)	28 (712)	26 (661)	6 (153)	86 (2185)																																																																																												
33"	45°	86 (2185)	4 (102)	26 (661)	10 (254)	86 (2185)																																																																																												
46"	45°	105 (2667)	4 (102)	34 (864)	9 (229)	105 (2667)																																																																																												
<b>Triple Element</b>																																																																																																		
24"	0°	31 (788)	31 (788)	34 (864)	9 (229)	105 (2667)																																																																																												
33"	45°	105 (2667)	4 (102)	34 (864)	10 (254)	105 (2667)																																																																																												
46"	45°	105 (2667)	4 (102)	34 (864)	10 (254)	105 (2667)																																																																																												
<p>Read and understand the installation, operating, and maintenance instructions thoroughly before installing or servicing this equipment. Failure to properly apply product may result in property damage, injury, or death.</p>																																																																																																		
<p><b>HOT.</b> Do not touch any part of the heater while in operation.</p>																																																																																																		
<p>Apply proper voltage.</p>																																																																																																		
<p>Diagram showing SIDE VIEW - 0°, END VIEW - 0°, and END VIEW - 45°.</p>																																																																																																		

**CAUTION**

VERIFY SUPPLY VOLTAGE - VÉRIFIEZ LA TENSION D'ALIMENTATION

DISCONNECT FROM ELECTRICAL SUPPLY BEFORE SERVICING THIS HEATER. DÉBRANCHEZ DE L'ALIMENTATION ÉLECTRIQUE AVANT L'ENTRETIEN DE CET APPAREIL DE CHAUFFAGE.

THIS APPLIANCE MUST BE PROPERLY GROUNDED TO THE ELECTRICAL SOURCE. CET APPAREIL DOIT ÊTRE CORRECTEMENT MIS À LA TERRE À LA SOURCE ÉLECTRIQUE.

NOTE: USE COPPER CONDUCTORS ONLY. ATTENTION: UTILISER DES CONDUCTEURS EN CUIVRE. (UL6186-1-010) (CSA)

Electrical Label (Located inside the raceway)

F/N: LLECL001a - Clearances to Combustibles Label

**WARNING**

Avoid Serious Injury, Death, or Property Damage. Maintain Clearances to Combustible to Prevent the Risk of Fire.

Clearances to combustibles must be maintained at all times in order to prevent the ignition of combustible materials. In locations used for the storage of combustible materials, signs must be posted to specify the maximum permissible stacking height to maintain the required clearances from the heater to the combustibles. Signs must either be posted adjacent to the heater's thermostats or, in the absence of such thermostats, in a conspicuous location. Clearances are provided on the heater's safety label and in the heater's Installation, Operation, and Maintenance manual. Product installation and operation must comply with applicable standards, codes, and regulations. Post this tag adjacent to the heater's thermostat or controls before operating the heater.

California Proposition 65

This product can expose you to chemicals including lead and carbon monoxide, which are known to the State of California to cause birth defects or other reproductive harm.

For more information go to [www.P65Warnings.ca.gov](http://www.P65Warnings.ca.gov).

**- INSTALLER: READ AND POST THIS NOTICE -**

F/N: LL001 - Clearance Safety Tag (Affix adjacent to heater's controller)

**ELECTRIC INFRARED HEATER**

INFRAROUGE À CHAUFFE AU ÉLECTRIQUE

MODEL NUMBER / NUMÉRO DE MODÈLE: MEL-24B1-120

SERIAL NUMBER / NUMÉRO DE SÉRIE: 2002MODIXXXXXX0001

VOLTAGE / TENSION: 120	WATTS RANGE / PLAGE DE PUISSANCE: 750-1600	PHASE: Single	VERSION: 01/20
MIN. MOUNTING HEIGHT / HAUTEUR MINIMALE DE MONTAGE: 10'	MIN. MOUNTING ANGLE / MIN. ANGLE DE SUPPORT: 0°	MAX. MOUNTING ANGLE / MAX. ANGLE DE SUPPORT: 45°	FREQUENCY / FRÉQUENCE: 50/60 Hz

UL 2021 - Edition 6 (revision 2018) • CSA C22.2 46-13 (R2018)

Element Part Number: EL-HO-A24

Output Wave: H.O. Medium

Amps per Lamp / Total Amps: 11.30 / 11.30

Watts per Lamp / Total Watts: 1360 / 1360

Modine Manufacturing Company  
21400 Hoover Road, Warren, MI 48089  
(586) 759-9550

FOR COMMERCIAL, INDUSTRIAL, AND OUTDOOR RESIDENTIAL USE. FOR INDOOR OR OUTDOOR USE. MADE IN USA.

Rating Plate

## **Standards, Certifications, and Government Regulations**

Installation of this infrared heater must comply with all applicable local, state, and national specifications, regulations, and building codes. Contact the local building inspector and/or fire marshal for guidance.

The heater must be electrically grounded in accordance with the following codes:

**United States:** Refer to National Electrical Code®, ANSI/NFPA 70 (latest edition).  
Wiring must conform to the latest edition of National Electrical Code®, local ordinances, and any special diagrams from the manufacturer.

**Canada:** Refer to Canadian Electrical Code CSA C22.1 Part 1 (latest edition).

**Modine units comply with or are certified by one or more of the following organizations or standards:**

- UL 2021
- CSA 22.2 #46 - M1988

## 2.0 Installation

### ⚠ WARNING



Read and understand the installation, operation, and maintenance instructions thoroughly before installing or servicing this equipment.

### Design

To ensure a safe, properly designed heating system, a layout should be developed for the correct placement of the infrared heater(s).

Aside from safety factors such as clearances to combustibles (see Chart 1.5 on page 8), consideration should also be given to factors such as the environment (e.g., cold/drafty, average, protected), heat coverage (sq. ft.) needed, heater centers, the distance behind a person or work station(s), etc. Also, the effective infrared surface temperature of a person or object may be diminished with wind above 5 mph. Wind barrier(s) may be required. Most importantly, clearances to combustibles **must** always be maintained! Refer to hazards on page 7.

When positioning the heaters, keep in mind the location of combustible materials, lights, sprinkler heads, overhead doors, storage areas with stacked materials, gas and electrical lines, parked vehicles, cranes, etc. Refer to page 6 for minimum clearances to verify that a safe installation exists.

This installation manual, along with national, state, provincial, and local codes, addresses these issues. It is critical that you read, understand, and follow all guidelines and instructions. Always inspect and evaluate the mounting conditions, application, and wiring.

When heated, materials high in hydrocarbons (solvents, paint thinner, mineral spirits, formaldehydes, etc.) can evaporate and/or degrade. This may result in odors or fumes being emitted into the environment. To correct this problem, clean the area and/or introduce additional ventilation. Heaters installed and serviced in accordance with the installation manual do not emit foul odors into the environment.

**IMPORTANT:** Fire sprinkler heads must be located at an appropriate distance from the heater to avoid an inadvertent discharge. This distance may exceed the published clearances to combustibles. Certain applications may require the use of high temperature sprinkler heads or relocation of the heaters.

### ⚠ CAUTION

Fire sprinkler systems containing propylene glycol, antifreeze, or other potentially flammable substances shall not be used in conjunction with this heater without careful consideration for, and avoidance of, inadvertent discharge hazards. For further information consult applicable NFPA codes. Always observe applicable state and local codes.

Chart 2.1 • Estimating Required Heat Load

Type of Building	Watts Required per Square Foot at Floor Level*
Insulated	5 to 10
Uninsulated	10 to 15
Outdoor Sheltered	20 to 30
Outdoor Unsheltered	25 to 40

\* For load purposes only, not for determining coverage.

When comfort heating people, two heaters should be used to heat both sides of the individual. Heater installation shall comply with all IOPM, NEC, ANSI/NFPA-70, CEC, and local restrictions.

Chart 2.2 • Heating Application Chart

Series	Lamp Quantity	Minimum Mounting Height (Ft.)		Recommended Mounting Height (Ft.)** [Dim. A]	Recommended Distance Between Heaters (Ft.) [Dim. B]	Approximate† Square Foot Coverage
		US	Canada			
MEL-24	1	6 ft.	2.4 m	10 to 12	5 to 10	100 to 200
	2	7.5 ft.	2.4 m	10 to 12	6 to 12	150 to 250
	3	9 ft.	2.8 m	12 to 14	7 to 14	200 to 300
MEL-33	1	6 ft.	2.4 m	10 to 12	6 to 12	200 to 300
	2	7.5 ft.	2.4 m	12 to 14	7 to 14	250 to 350
	3	9 ft.	2.8 m	12 to 14	8 to 16	300 to 400
MEL-46	1	6 ft.	2.4 m	12 to 14	7 to 14	300 to 400
	2	7.5 ft.	2.4 m	14 to 16	8 to 16	350 to 450
	3	9 ft.	2.8 m	14 to 16	9 to 18	400 to 500

\*\* Clearances to combustibles published in this manual and on safety labels must be maintained at all times. Factory recommended mounting heights are listed as a guideline. If infrared heaters are mounted too low or too high, they may result in discomfort or lack of heat.

† Approximation only. Mounting height and environmental conditions will impact performance.

Figure 2.1 • Heating Application

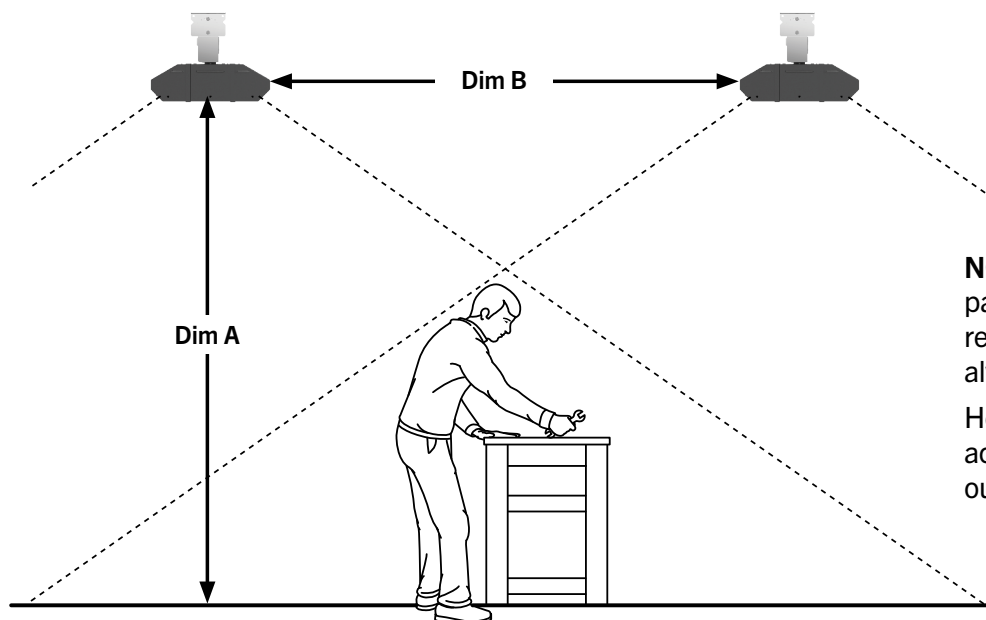

**NOTE:** Typical height above patrons is 2 to 6 ft. (minimum required mounting height must always be maintained).

Heat loads estimated are to achieve a perceived 10° to 15°F outdoor temperature rise.

## Heater Mounting

### ⚠ WARNING



Improper suspension of the infrared heater may result in collapse and being crushed. Always suspend from a permanent part of the building structure that can support the total force and weight of the heater.



Failure to maintain minimum clearance to combustibles may result in fire and/or explosion, property damage, serious injury, or death. Always maintain minimum clearances and post signs or provided tags (F/N: LL001) adjacent to heater's controller. Signs should state the hazards for the particular application and be legible to the building occupants. Consult the factory or a factory representative for additional information on signage compliance.

The heater can be suspended with chains or rigid threaded rod. Local codes, or conditions that would cause the unit to move (e.g., wind drafts, blowers, crane rails, etc.), may require rigid threaded rod. Consult all applicable codes before installation.

Clearances to combustibles must be maintained when using recessed mount kits (P/N: ELx-FRxx). For additional information, refer to form # LSH123a - Recessed Mounting Frame Installation Instructions or contact the factory.

The heater must be level from end to end and may be 0° to 45° on horizontal. Refer to Figures 2.2 and 2.3.

Figure 2.2 • Heater Dimensions

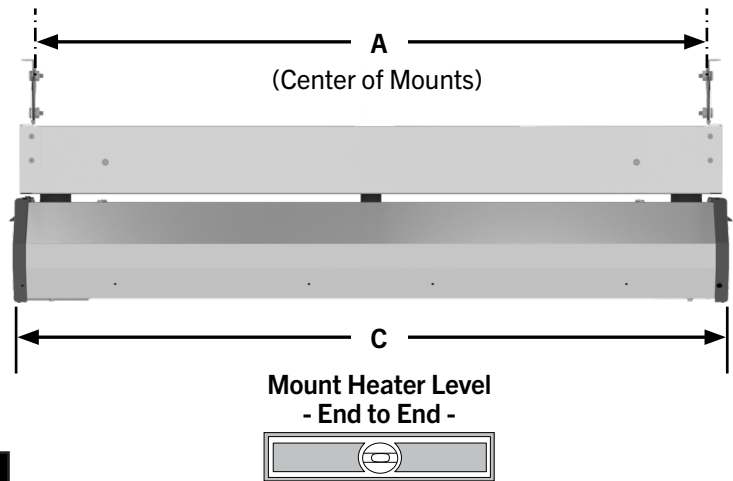
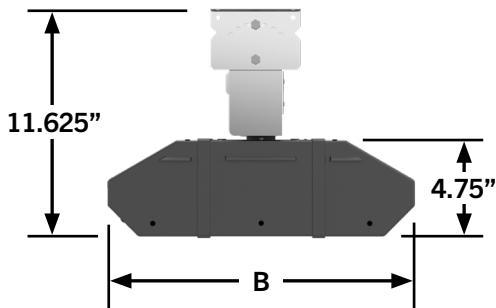
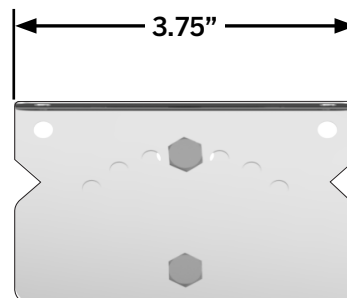

Chart 2.3 • Physical Dimensions (inches)

Model No.	A	B	C
MEL-24B1	23.50	9.625	24.50
MEL-24B2	23.50	15.25	24.50
MEL-24B3	23.50	21.00	24.50
MEL-33B1	32.50	9.625	33.50
MEL-33B2	32.50	15.25	33.50
MEL-33B3	32.50	21.00	33.50
MEL-46B1	45.50	9.625	46.50
MEL-46B2	45.50	15.25	46.50
MEL-46B3	45.50	21.00	46.50

Figure 2.3 • Mounting Centers



## Top Channel Assembly

- ① Attach the mounting brackets to the top wire raceway. On each end, place (1)  $\frac{1}{4}$ " x  $\frac{1}{2}$ " bolt through the bottom hole of the mounting bracket and through the bottom hole of the top wire raceway. Place (1)  $\frac{1}{4}$ " lock nut on each bolt. Do not tighten completely. Refer to Figure 2.4.

**NOTE:** The mounting brackets are **NOT** required for chain suspension.

- ② Adjust wire raceway to desired mounting angle.
- ③ On each side, place (1)  $\frac{1}{4}$ " x  $\frac{1}{2}$ " bolt through slot in the mounting bracket and the hole in the top wire raceway. Place (1)  $\frac{1}{4}$ " lock nut on each bolt and tighten.
- ④ Tighten lock nuts from Step 1.
- ⑤ Hook heater body into mounted wire raceway. Unit will hang freely by the "T" hinge, leaving both hands free to wire unit. Refer to Figure 2.4.
- ⑥ Run supplied high temperature wires out to field supplied junction box. **DO NOT** make connections inside the wire raceway.
- ⑦ Close wire raceway using the (4) #8-32 x  $\frac{3}{8}$ " grounding screws provided in hardware pack.

Figure 2.4 • Top Channel Assembly

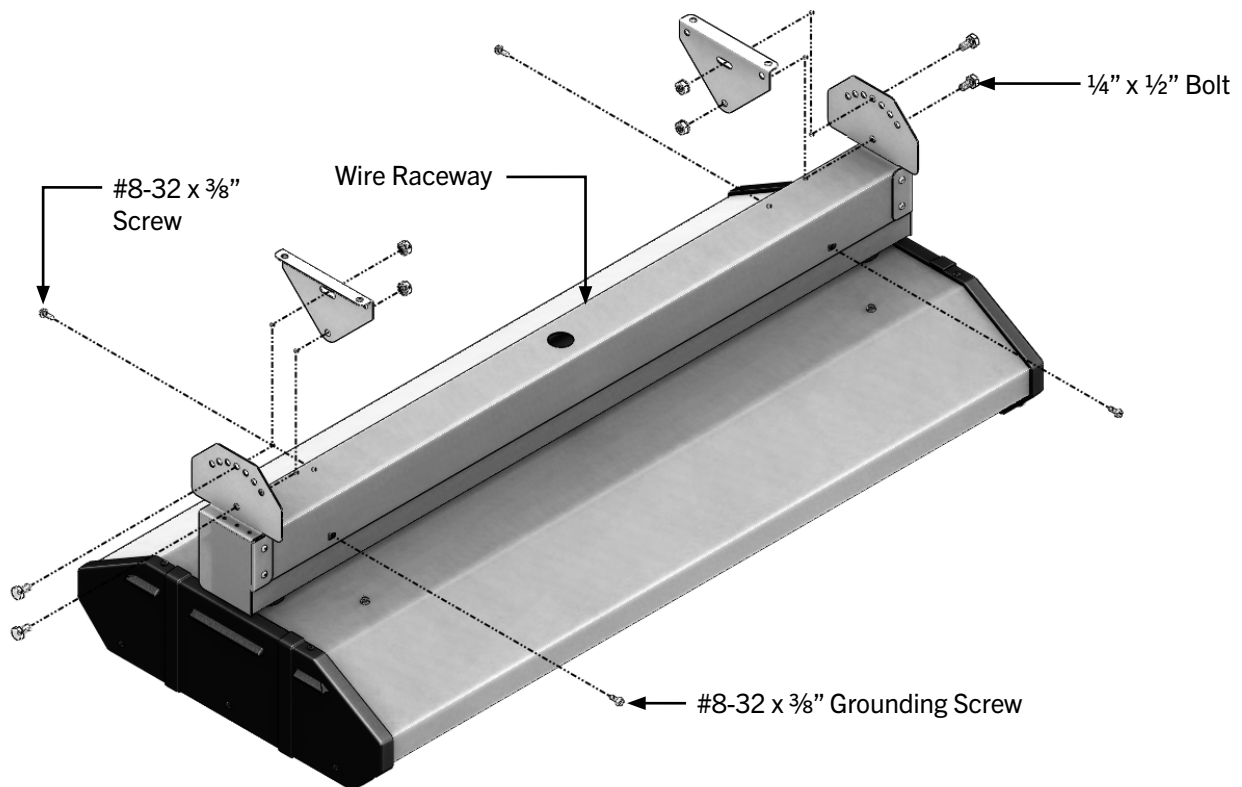

## Lamp Installation

### ⚠ CAUTION

Disconnect power prior to installing or replacing supplied quartz lamp(s). The elements can and should be installed prior to mounting the heater.

- ① Ensure appliance is OFF and is cool to the touch.
- ② Remove both service access panels using a ¼" nut driver.
- ③ Open lamp retainers by rotating the retainers on both sides of the unit (see Figure 2.5).
- ④ Position heating elements in "U" slots and firmly press the ceramic connector end into the clip(s), one end at a time. Avoid handling the quartz glass as much as possible.
- ⑤ Remove the top element wire retaining nut. Slide the ring terminal over the bolt until it meets the bottom retaining nut. Replace top retaining nut and torque to 15 in.-lbs. Do not overtighten.
- ⑥ Rotate the lamp retainer into closed position.
- ⑦ Repeat steps 3 through 6 until all heating elements have been installed.
- ⑧ After heating elements have been installed, the quartz glass should be wiped down with alcohol using a clean cloth.
- ⑨ Reinstall the service access panels.

Figure 2.5 • Lamp Installation

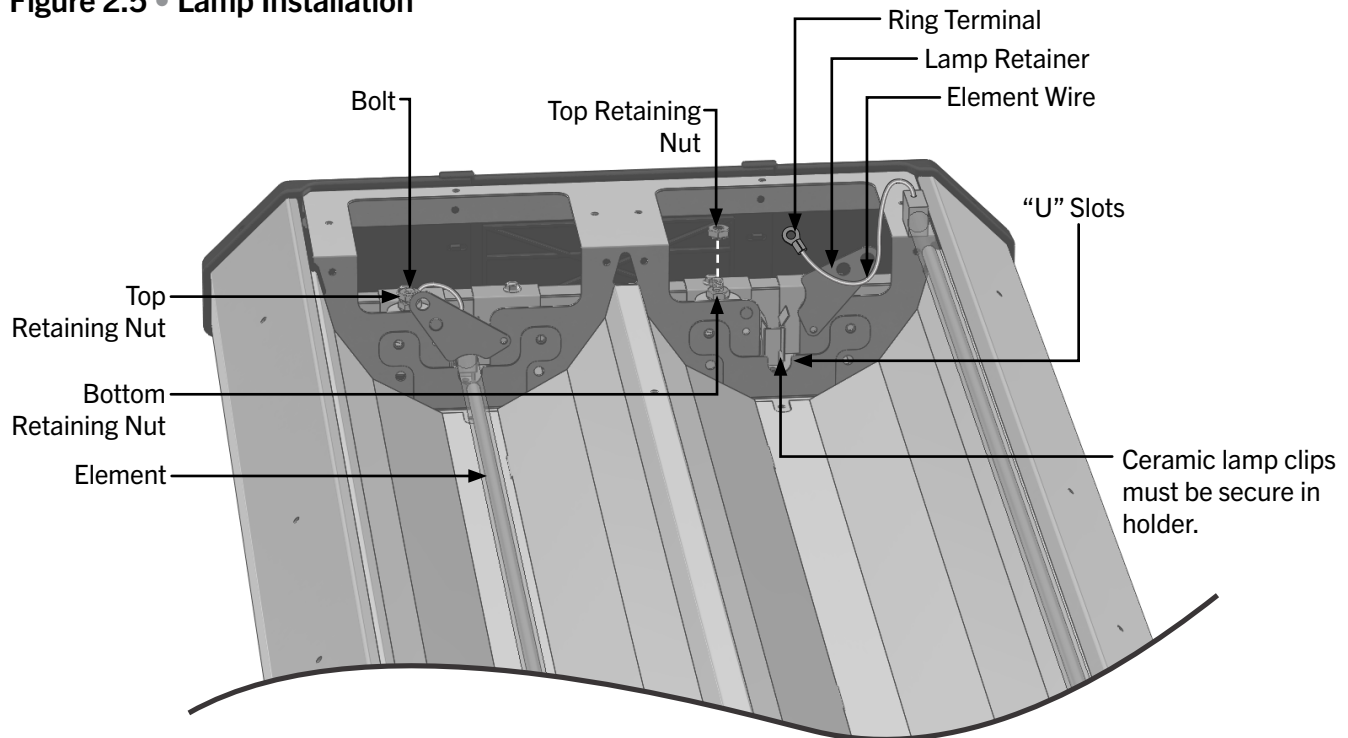

**NOTE:** MEL series heaters are designed for use with quartz lamp infrared heating elements only. They are NOT intended to be used with straight metal rod heating elements. Replace lamps with parts from Modine only!

## Outdoor Applications

### ⚠ CAUTION

For totally exposed outdoor applications (not ceiling protected) ensure connections are made as illustrated in Figure 2.6.

Figure 2.6 • Outdoor Application

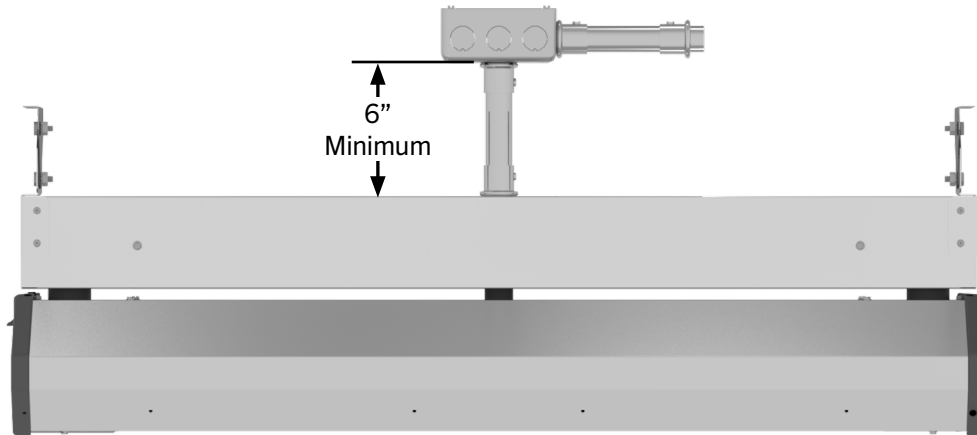

**NOTE:** All conduit, conduit fittings, and junction boxes are field supplied. Must be NEMA Type 4X or equivalent. Heater must be suspended from mounting brackets.

## Electrical

### ⚠ WARNING



#### Electric Shock

Field wiring to the heater must be connected and grounded in accordance with national, state, provincial, and local codes, and to the guidelines in this manual. In the United States, refer to the most current revisions to the ANSI/NFPA 70 Standard and in Canada, refer to the most current revisions to the CSA C22.1 Part I Standard.

Disconnect power to heater before servicing.

Failure to follow these instructions can result in death or electrical shock.

This fixture is equipped with high temperature silicone lead wires to make connections to branch circuit. Remove the wire ties prior to making electrical connections.

Wiring connections should always be through one of the knockouts in the top wire raceway. Wire connections must also be made outside of the top of the wire raceway. Consult the factory or a qualified electrician for details on staging.

Supply wires must be a copper conductor type with a minimum size of 10 AWG suitable for at least 200°C.

The heater must be connected to the earthing conductor (green wire) installed by the factory.

Reference top of page 16 for use in outdoor applications.



## Wiring Diagrams

Figure 2.7 • Wiring Diagram for Units with 1 Lamp



Figure 2.8 • Wiring Diagram for Units with 2 Lamps

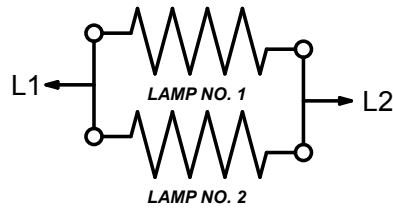
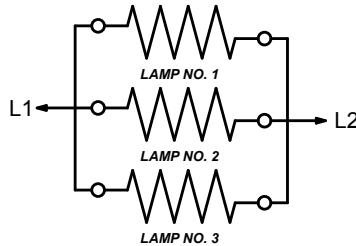

Figure 2.9 • Wiring Diagram for Units with 3 Lamps



## Field Wiring

Figure 2.10 • Single Phase Service  
Heaters are built as single phase.

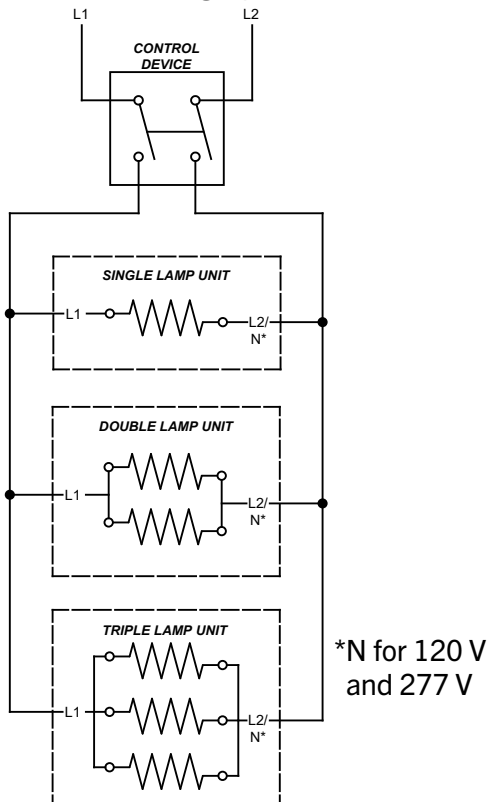
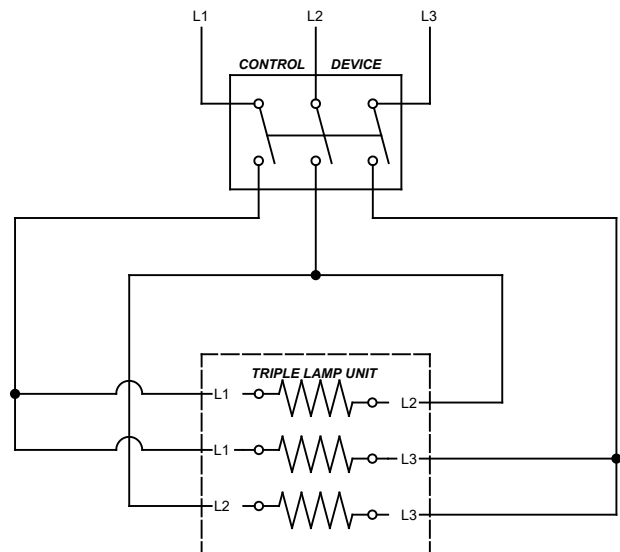

Figure 2.11 • Three Phase Service  
Field configured.





### Troubleshooting Guide

Key					
	Start Question		Process Question		Corrective Action

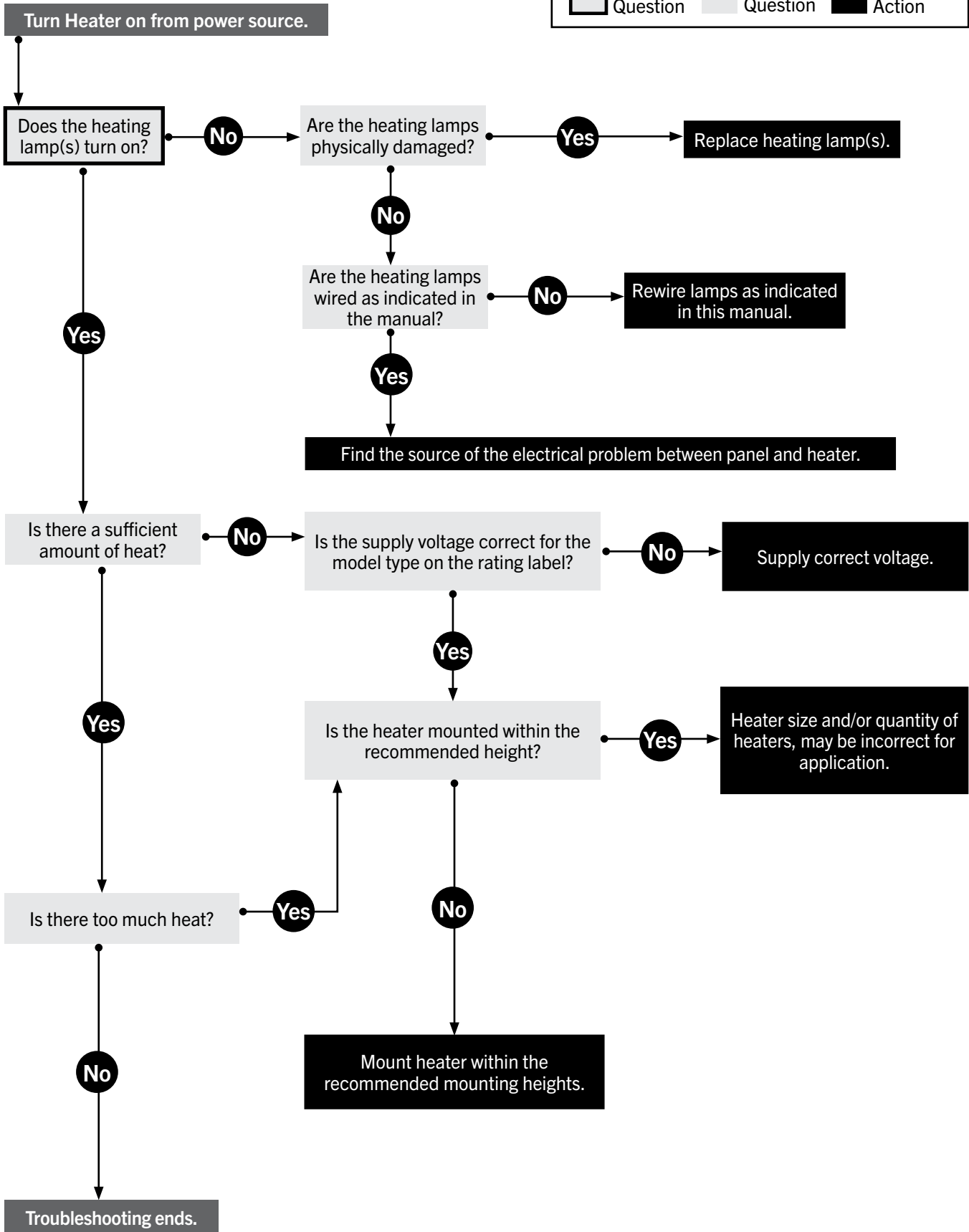

## Heater Assembly Components

For complete information on MEL series replacement parts, contact your installation contractor.

Figure 3.1 • Components

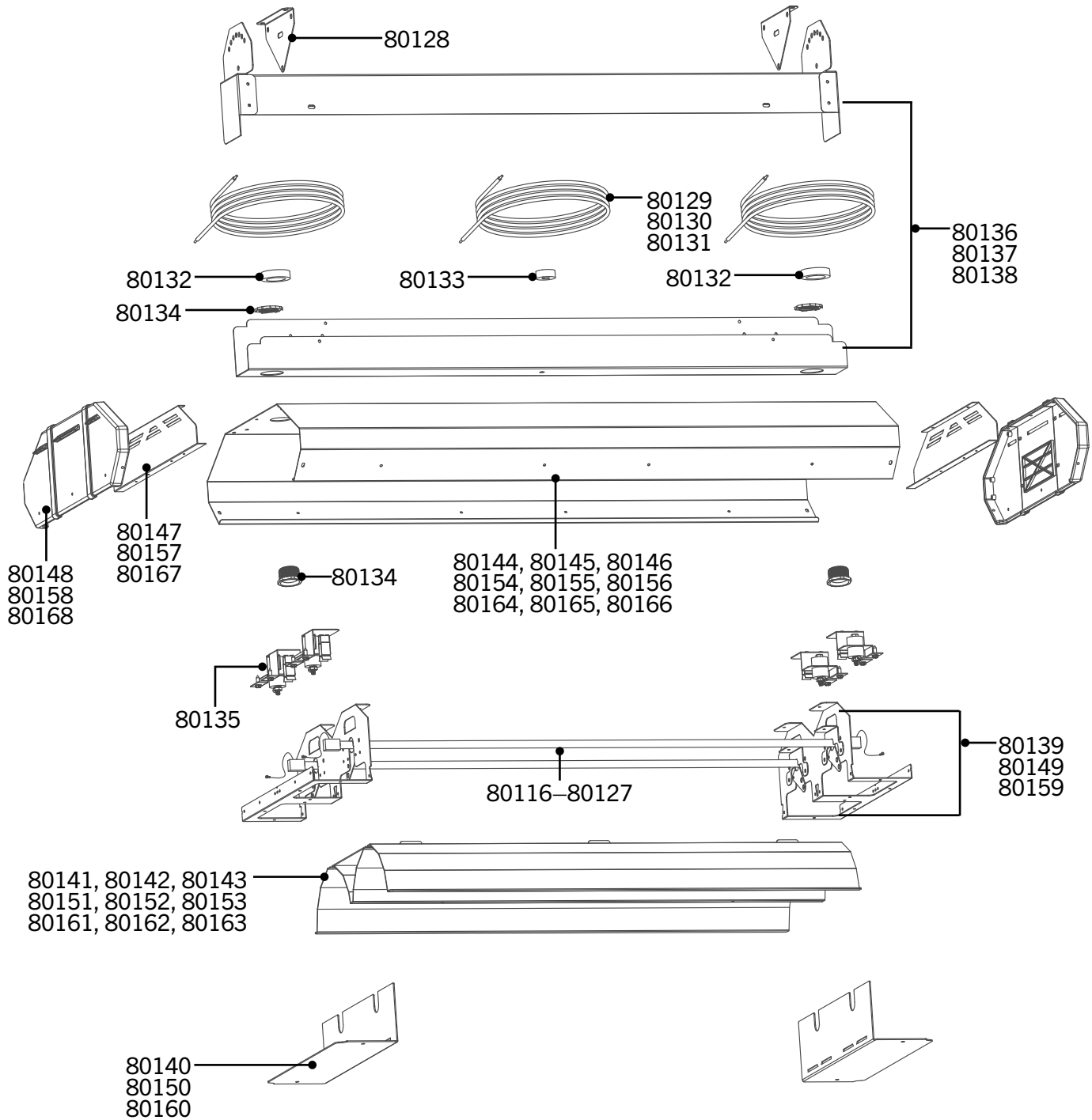

## Parts List

Chart 3.1 • General Parts

Part No.	Description	Part No.	Description
80128	Mounting Brackets (set of 2)	<b>Double Element Model-Specific Parts</b>	
80129	12 Gauge Wire Length for 33" (specify color)	80149	Chassis Assembly with Lamp Stopper
80130	12 Gauge Wire Length for 24" (specify color)	80150	Service Access Panel - Vented
80131	12 Gauge Wire Length for 46" (specify color)	80151	Reflector, 24" Model
80132	Large Rubber Spacer (End - 2 per heater)	80152	Reflector, 33" Model
80133	Small Rubber Spacer (Center)	80153	Reflector, 46" Model
80134	Wire Bushing	80154	Shell Assembly, 24" Model
80135	Element Connector Assembly	80155	Shell Assembly, 33" Model
80136	Wire Raceway Assembly, 24" Model	80156	Shell Assembly, 46" Model
80137	Wire Raceway Assembly, 33" Model	80157	Rain Shield - Vented
80138	Wire Raceway Assembly, 46" Model	80158	Nylon End Panel
<b>Single Element Model-Specific Parts</b>		<b>Triple Element Model-Specific Parts</b>	
80139	Chassis Assembly with Lamp Stopper	80159	Chassis Assembly with Lamp Stopper
80140	Service Access Panel - Vented	80160	Service Access Panel - Vented
80141	Reflector, 24" Model	80161	Reflector, 24" Model
80142	Reflector, 33" Model	80162	Reflector, 33" Model
80143	Reflector, 46" Model	80163	Reflector, 46" Model
80144	Shell Assembly, 24" Model	80164	Shell Assembly, 24" Model
80145	Shell Assembly, 33" Model	80165	Shell Assembly, 33" Model
80146	Shell Assembly, 46" Model	80166	Shell Assembly, 46" Model
80147	Rain Shield - Vented	80167	Rain Shield - Vented
80148	Nylon End Panel	80168	Nylon End Panel

Chart 3.2 • Elements

Part No.	Description
80116	120 V, 1360 W, 24" Long
80117	208 V, 1360 W, 24" Long
80118	240 V, 1360 W, 24" Long
80119	277 V, 1360 W, 24" Long
80120	480 V, 1360 W, 24" Long
80121	208 V, 2125 W, 33" Long
80122	240 V, 2125 W, 33" Long
80123	277 V, 2125 W, 33" Long
80124	480 V, 2125 W, 33" Long
80125	277 V, 3200 W, 46" Long
80126	480 V, 3200 W, 46" Long
80127	575 V, 3200 W, 46" Long

# WARRANTY

## Heating and Indoor Air Quality Products

This Warranty (the "Warranty") shall apply to Products (as defined below) sold by Modine Manufacturing Company, a Wisconsin corporation ("Seller") to you ("Buyer").

Seller hereby warrants that during the Applicable Warranty Period (as defined below) its Products shall be free from defects in material and factory workmanship under normal use and service, subject to the EXCLUSIONS described below and according to the terms outlined in this Warranty.

If Seller receives written notice of a breach of this Warranty prior to the end of the Applicable Warranty Period (which such notice shall include the model and serial numbers of the Product, as well as the date and a reasonably detailed description of the Product's alleged failure), Buyer shall with Seller's prior written approval, return the applicable Product or component thereof to Seller with shipping charges prepaid; if upon examination by Seller such Product or component thereof is disclosed to have been defective, then Seller will, without charge to Buyer, at Seller's option, either repair the Product, replace defective parts in the Product, or offer an entire replacement unit of the Product; provided that the warranty period for a Product that has been repaired or provided with replacement parts shall not extend beyond the original Applicable Warranty Period, nor shall any replacement parts provided for a Product be under any warranty beyond the original Applicable Warranty Period for the Product; similarly, if Seller provides an entire replacement unit of the Product, the warranty period for the replacement unit is limited to the remainder of the original Applicable Warranty Period. Seller shall have no responsibility for installation, service, field labor, shipping, handling, or other costs or charges, except as expressly provided in this Warranty. Buyer shall have no remedy hereunder for any defective part returned without proper written authorization from Seller, as described above.

For purposes of this Warranty and subject to the exclusions described below, the term "Products" shall mean parts or equipment manufactured by Seller, sold to Buyer pursuant to a purchase contract between Buyer and Seller (most often initiated by a purchase order issued by Buyer and accepted by Seller), and expressly described in such contract. The term "Products" shall not include third-party parts or equipment furnished by Seller, except that, to the extent assignable, Seller will assign to Buyer the benefits (together with all limitations and exclusions) of the thirdparty manufacturer's warranty for such parts or equipment. This Warranty extends only to the original purchase contract between Buyer and Seller and is nontransferable, except that this Warranty may be assigned to an Authorized End User (as defined below). All replaced parts or equipment shall become Seller's property. For purposes of this Warranty, the term "Applicable Warranty Period" shall mean the warranty period set forth in the table below for each type or class of Product described on the table; provided that, when the Product is to be used as a component part of equipment manufactured by Buyer, the Applicable Warranty Period shall be limited to one (1) year after the date of shipment from Seller, notwithstanding anything in the table below to the contrary. For purposes of this Warranty, the term "Authorized End User" shall mean any third-party that purchases the Product directly or indirectly from Buyer for the Authorized End User's own use upon the first installation of the Product and not for resale.

BUYER HEREBY ACKNOWLEDGES THAT ITS REMEDIES FOR BREACH OF THIS WARRANTY, EXCLUSIVE OF ALL OTHER REMEDIES PROVIDED BY LAW, ARE LIMITED AS DESCRIBED ABOVE.

EXCLUSIONS AND LIMITATIONS: This Warranty is subject to the following exclusions and limitations:

The term "Products" shall not include and this Warranty shall not apply to any of the following items: refrigerant gas, belts, filters, fuses and other items consumed or worn out by normal wear and tear.

In addition, this Warranty shall not apply to:

- (1) Products or components thereof that are damaged or adversely affected by conditions beyond Seller's control, including but not limited to polluted or contaminated or foreign matter contained in the air or water utilized for heat exchanger (condenser) cooling or if the failure of the part is caused by improper air or water supply, or improper or incorrect sizing of power supply;
- (2) Any Products or components thereof which have been repaired or altered outside the factory of Seller in any way, or otherwise subject to unauthorized repairs or alterations, so as, in the judgment of Seller, to affect the Product's durability or performance;
- (3) Materials or labor of any kind not furnished by Seller, or any charges for any such labor or materials, whether such labor, materials or charges thereon are due to replacement of parts, adjustments, repairs, or any other work done by any party other than Seller;
- (4) Labor or other costs incurred for diagnosing, repairing, removing, installing, shipping, servicing, or handling of either defective or replacement parts;
- (5) Any Products removed from their original location for reinstallation in another location;
- (6) Any Products or components thereof which have been operated, maintained, or serviced contrary to Seller's written installation, operation, and/or servicing instructions or owner's manual;
- (7) Damages resulting from operation with an inadequate or interrupted supply of air or water;
- (8) Any Products or components thereof which have been subjected to misuse, negligence, faulty installation, improper servicing, accident, excessive thermal shock, excessive humidity, physical damage, impact, abrasion, improper operation, or other operating conditions in excess of or contrary to those for which such equipment was designed;
- (9) With respect to gas-fired or oil-fired units, any Products or components thereof if the input to the Product exceeds the rated input (as indicated on the Product's serial plate) by more than five percent (5%);
- (10) Any Products or components thereof which, in the judgment of Seller, have been installed in a corrosive atmosphere, marine, or coastal application, subjected to corrosive fluids or gases, or damaged or adversely affected by the effects of the physical or chemical properties of water or steam or other liquids or gases used in the Products or any component thereof;
- (11) Damage or failure to start resulting from improper voltage conditions, blown fuses, open circuit breakers, or other inadequacy or interruption of electrical service or fuel supply; or
- (12) Any Products or components thereof from which the serial number has been altered, defaced or removed.

BUYER AGREES THAT THE WARRANTIES AND REMEDIES DESCRIBED HEREIN ARE THE ONLY WARRANTIES AND REMEDIES PROVIDED BY SELLER WITH RESPECT TO THE PRODUCTS AND TO THE MAXIMUM EXTENT PERMITTED UNDER APPLICABLE LAW SHALL BE IN LIEU OF AND EXCLUSIVE OF ALL OTHER WARRANTIES AND REMEDIES WHATSOEVER, EITHER EXPRESS OR IMPLIED, WHETHER ARISING FROM LAW, COURSE OF DEALING, USAGE OF TRADE, OR OTHERWISE, **INCLUDING BUT NOT LIMITED TO WARRANTIES OF MERCHANTABILITY, FITNESS FOR A PARTICULAR PURPOSE, AND NON-INFRINGEMENT, EACH OF WHICH SELLER HEREBY EXPRESSLY DISCLAIMS.** SELLER NEITHER ASSUMES (NOR HAS AUTHORIZED ANY PERSON TO ASSUME) ANY OTHER WARRANTY OR LIABILITY IN CONNECTION WITH ANY PRODUCTS. REPRESENTATIONS AND CONDITIONS, EXPRESS OR IMPLIED BY STATUTE, TRADE USAGE, OR OTHERWISE, ARE EXCLUDED AND WILL NOT APPLY TO THE PRODUCTS UNDER THIS WARRANTY, EXCEPT FOR WARRANTIES WHICH BY LAW CANNOT BE EXCLUDED OR LIMITED. Without limiting the foregoing, Seller makes no and specifically disclaims all representations and/or warranties

that the Products will detect the presence of, or eliminate, prevent, treat, or mitigate the spread, transmission, or outbreak of any pathogen, disease, virus, or other contagion, including but not limited to COVID19.

BUYER AGREES THAT IN NO EVENT WILL SELLER BE LIABLE FOR COSTS OF PROCESSING, LOST REVENUES OR PROFITS, INJURY TO GOODWILL, OR ANY OTHER SPECIAL, CONSEQUENTIAL, OR INCIDENTAL DAMAGES OF ANY KIND RESULTING FROM THE PURCHASE OF THE PRODUCTS, OR FROM BUYER'S USE OF ANY PRODUCT, WHETHER ARISING FROM BREACH OF WARRANTY, NONCONFORMITY TO ORDERED SPECIFICATIONS, DELAY IN DELIVERY, OR ANY OTHER LOSS SUSTAINED BY THE BUYER.

OPTIONAL SUPPLEMENTAL WARRANTY

Buyer may purchase from Seller a supplemental warranty with respect to Products which shall extend the Applicable Warranty Period as set forth in the express terms and conditions described in the supplemental warranty agreement. Such supplemental warranty terms may include an additional four (4) years on certain compressors, an additional five (5) years "all parts" warranty, an additional four (4) or nine (9) years on certain heat exchangers, and/or such additional supplemental warranty terms as Seller chooses to make available to its customers from time to time.

COMPONENT	APPLICABLE MODELS		APPLICABLE WARRANTY PERIOD (WHICHEVER OCCURS FIRST)	
			Time from Date of First Beneficial Use by Buyer or Authorized End User	Time from Date of Shipment from Seller
Heat Exchangers and/or Coils	Gas Fired Unit Heaters with Tubular Style Heat Exchangers (e.g. HD, HDS, PTS, BTS, etc.)	Aluminized or Stainless Steel	10 YEARS	126 MONTHS
	Gas Fired Unit Heaters with Clam-Shell Style Heat Exchangers (e.g. PDP, BDP, etc.)	Aluminized Steel (not in high-humidity applications)	10 YEARS (must be Stainless Steel in high-humidity applications)	126 MONTHS
		Aluminized Steel (in high-humidity applications)	1 YEAR	18 MONTHS
		Stainless Steel	10 YEARS	126 MONTHS
	Low Intensity Infrared Units		5 YEARS	66 MONTHS
	Indoor and Outdoor Duct Furnaces and System Units, Steam/Hot Water Units, Oil-Fired Units, Electric Units, Cassettes, Vertical Unit Ventilators, Geothermal Units		1 YEAR	18 MONTHS
Burners and Elements	Low Intensity Infrared Units		2 YEARS	30 MONTHS
	High Intensity Infrared and Electric Infrared Units		1 YEAR	18 MONTHS
Compressors	Condensing Units for Cassettes		5 YEARS	66 MONTHS
	Vertical Unit Ventilators, Geothermal Units		1 YEAR	18 MONTHS
Sheet Metal Parts	All Products		1 YEAR	18 MONTHS
Components excluding Heat Exchangers, Coils, Condensers, Burners, Sheet Metal	All Products		2 YEARS	30 MONTHS

As Modine Manufacturing Company has a continuous product improvement program, it reserves the right to change design and specifications without notice.

