



STEAM/HOT WATER UNIT HEATERS



MODEL HSB/HC



MODEL V/VN



MODEL PT/PTN



MODEL HCH



MODEL BCH

Table of Contents	Page
I. Design Benefits	
A. Application, Design, Construction Overview.....	3
B. Unit Features – Horizontal Delivery Unit Heaters.....	4
C. Unit Features – Vertical Delivery Unit Heaters.....	5
D. Unit Features – Power-Throw™ Horizontal Delivery Unit Heaters.....	5
E. Options and Accessories.....	6
F. Power Code Descriptions & Control Sequence.....	7
II. Performance Data	
A. Breeze™ AccuSpec Sizing and Selection Program.....	8
B. Steam Conversion Tables.....	9
C. Steam Performance Data – Standard Models.....	12
D. Steam Performance Data – Low Outlet Temperature Models.....	13
E. Steam Conversion Tables – Example Calculations.....	14
F. Hot Water Conversion Tables.....	15
G. Hot Water Performance Data – Standard Models.....	18
H. Hot Water Performance Data – Low Outlet Temperature Models.....	19
I. Hot Water Performance Data – High Efficiency Low EWT Models.....	20
J. Hot Water Conversion Tables – Example Calculations.....	21
K. Maximum Mounting Heights for Outlet Accessories, Dimensions.....	22
L. Motor Data, Step-Down Transformer Accessory Data.....	23
M. Cooling Performance Data.....	24
III. Dimensional Data	
A. Dimensions – Horizontal Air Delivery Models.....	25
B. Dimensions – Horizontal Air Delivery High Efficiency Models.....	26
C. Dimensions – Vertical Air Delivery Models.....	27
IV. Model Identification	28
V. Specifications	29

Refer to page 8 for information regarding the
Breeze™ AccuSpec Sizing and Selection Program



As Modine Manufacturing Company has a continuous product improvement program,
it reserves the right to change design and specifications without notice.

Application, Design, Construction Overview - All Units

Wide Product Selection

- Ratings as low as 11,300 Btu/hr for hot water to as high as 952,000 Btu/hr for steam, based on standard conditions.
- Horizontal, Vertical, and Power-Throw™ (high velocity horizontal air delivery) models offer maximum application flexibility.
- Ratings are shown as Btu/hr (based on 2 PSI steam, 60°F entering air conditions), eliminating the need to convert from EDR. This simplifies the matching of unit ratings to building heat loss.

Application Flexibility

- Horizontal and Power-Throw™ units are furnished with louvers for directional control of heated air. Vertical units are available with various louver, truncone, and cone-jet deflector options to accommodate many different air distribution patterns. See page 22 for more information.
- Units are available as low outlet temperature (LOT) models. LOT models have coils with fewer fins per inch to reduce the output rating. This is a benefit for applications where the steam pressure exceeds 30 PSI and mounting height is critical; the lower output results in outlet air temperatures that approximate that of standard coils at standard steam pressure. LOT models are also well suited for dirty environments where the increased fin spacing decreases the build-up of foreign particles. Finally, LOT models offer lower airside resistance resulting in greater allowable mounting heights and greater heat throw.
- Vertical and Power-Throw™ units are available with 90/10 cupro-nickel coils for high pressure/temperature applications, up to 250 PSI or 400°F.
- Side piping connections on the HC/BCH/HCH horizontal air delivery model allow for low clearance installations.
- Explosion-proof motors are available for use in hazardous areas. See page 8 for additional details.
- Design assures the correct relationship between air temperature, velocity, and air volume for greater heat throw; air is delivered to the floor at maximum mounting height, increasing comfort and reducing fuel costs.

Ease of Installation/Maintenance = Reliability

- Units are compact and lightweight, requiring fewer contractor hours to install.
- All units include an electrical junction box, either integral to the motor or mounted on the unit casing, to allow for easy electrical connections.
- All motors are enclosed air over. All single phase and explosion-proof motors include internal overload protection to protect the motor from insulation damaging heat, resulting in longer motor life.
- Different suspension options are available for most units including threaded rod or pipe hanger adapters.
- All units are component tested for proper motor function and the coils are leak tested under pressure to ensure proper function when the unit arrives at the jobsite.
- Fins on all units are vertical to limit build-up of foreign particles, prolonging periods between cleanings. Fins on vertical and Power-Throw™ units are exposed for easy cleaning.

Blends with the Environment

- Quiet operation is assured through the use of carefully selected motors, fans, and scientifically designed venturi fan shrouds.
- HSB/HC/BCH/HCH models have squared off corners for a clean, defined appearance. Vertical and Power-Throw™ units have a pleasing circular symmetry.
- Casings are treated for corrosion resistance and finished with a neutral gray-green baked-on, electrostatically applied polyester powder coat paint finish.
- Casings are treated for corrosion resistance and finished with a gray baked-on, electrostatically applied polyester powder coat paint finish.

Unit Features - Horizontal Delivery Unit Heaters

Horizontal delivery unit heaters are the most popular of all types. These units are ideal for heating buildings with large open areas and low ceilings. They are used to counter heat loss along outside building walls, especially where windows are present.

In addition to the features noted on page 2, features that enhance the popularity of the horizontal delivery unit heater are:

- HSB units have top and bottom supply and return connections. This permits the unit to be rotated 360° without piping changes.
- HC units have side supply and return connections. This permits the unit to be installed in low clearance areas.
- HCH/BCH high efficiency units have side supply and return connections. This permits the unit to be installed in low clearance areas.
- BCH high efficiency units utilize blower fans, ideal for applications with static-pressure.
- Units have a 2-piece casing for easy coil access.
- All models have tapped holes for suspension by threaded rod or optional pipe hanger adapter kit, except HSB 18 and HSB 24 which mount directly to and are supported by the supply and return piping.
- Serpentine copper tube coil design has high resistance to thermal shock, even under high steam pressures.
- Absence of coil headers eliminates potential leaks and increases coil face area without increasing overall size of unit.
- Coil designed for greater water carrying capacity with lower friction loss.



Figure 4.1 - Unit Features

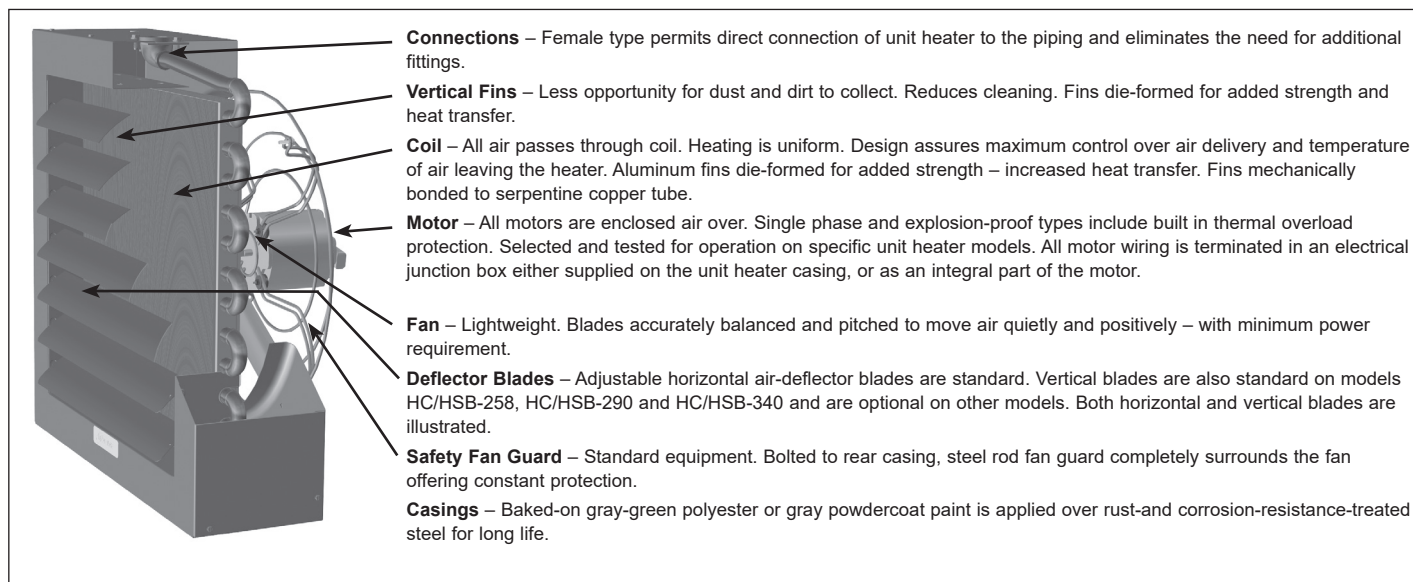

Unit Features - Vertical Delivery Unit Heaters

Vertical delivery unit heaters are ideal for heating buildings with high ceilings or areas that require the heater to be mounted above obstructions such as craneways. Selection from a variety of heat throw patterns is made easy by choosing from four types of air deflectors. Heat throw patterns range from a high-velocity narrow jet to a gentle-velocity broad based cone of heated air.

In addition to the features noted on page 2, features that enhance the popularity of the vertical delivery unit heater are:

- Extended motor life with the use of the standard motor cooling cone. The cooling cone protects the motor from intense radiant and convection heat from the coil when the fan is not running. The cone also meters a controlled volume of ambient air over the motor to reduce motor temperature, when the motor is running.
- All models through V/VN 279 have tapped holes for threaded rod or optional pipe hanger adapter kit.
- All models V/VN 333 and larger have angle-iron mounting bracket with 5/8" diameter hanger holes.
- All vertical units are supplied with an outlet fan guard covering the opening in the bottom of the unit.



Figure 5.1 - Unit Features

<p>Motor-Cooling Cone – Shields motor from coil heat - prolongs life of insulation, windings, and lubricant. Prolongs motor life (V/VN models only).</p>		<p>Junction Box – All motor wiring is terminated in an electrical junction box either supplied on the unit heater casing or as an integral part of the motor.</p>
<p>Coil – Aluminum fins firmly bonded to tubes for maximum heat transfer. Steam and water-carrying passages between extra-heavy steel pipe connections are copper for model V/PT and cupro-nickel for model VN/PTN.</p>		<p>Motor Easily Removable – Modine design permits motor to be removed through opening below the unit especially important where heaters are installed close to ceiling (V/VN models only).</p>
<p>Motor – All motors are enclosed air over. Single phase and explosion-proof types include built in thermal overload protection. Selected and tested for operation on specific unit heater models.</p>		<p>Vertical Fins – Less opportunity for dust and dirt to collect. Exposed for easy cleaning with air hose and brush.</p>
<p>Fan – Accurately balanced to operate quietly and at lowest possible power cost.</p>		<p>Casings – Baked-on, gray-green polyester powder coat paint applied over rust- and corrosion-resistance treated steel lasts longer.</p>

Unit Features - Power-Throw™ Horizontal Delivery Unit Heaters

Power-Throw™ horizontal delivery unit heaters are ideal for heating large buildings where a number of smaller units can be replaced by a few larger Power-Throw™ units. This results in a more economical installation. Their high velocity air delivery results in the greatest heat throw available.

Power-Throw™ units are also ideally suited for blanketing doors that frequently open.

Because of high velocity air delivery, care must be taken to avoid directing the air stream at building occupants.

In addition to the features noted on page 2, features that enhance the popularity of the Power-Throw™ horizontal delivery unit heater are:

- All models through PT/PTN 279 have hanger brackets with 5/8" diameter hanger holes for 3-point suspension.
- All models larger than PT/PTN 279 have hanger brackets with 5/8" diameter hanger holes for 2-point suspension and angle supports for 4-point suspension.
- Air distribution is controlled by a standard adjustable position horizontal louver assembly.
- The air stream can be concentrated into a high velocity jet or broadened to cover a greater area.
- Fan blades are properly balanced and pitched to move large volumes of high velocity air at relatively low sound levels.
- Refer to Figure 5.1 for features similar to the V/VN vertical models.



Options and Accessories

Table 6.1
Factory Mounted Options

Factory Mounted Option	Description
Fingerproof Fan Guard	Standard fan guard may be factory replaced with fingerproof fan guard. For HSB/HC/HCH units only. Not available for units with explosion-proof motors.

Table 6.2
Field Installed Accessories for Horizontal Models

Field Installed Accessories	Description
Vertical Deflector Blades	Blades used to deflect airflow in directions left or right of unit heater. Used in addition to standard horizontal deflector blades. Vertical deflector blades are standard on HSB/HC models 258 through 340.
Solid State Speed Control	Not available for Power-Throw™ models. Allows for remote control of airflow volume by controlling fan speed. Available only on HSB/HC models 18 through 108 with Power Code 01.
Discharge Hoods	Available for HCH units. 30°, 60°, and 90° downward deflector hoods
Drain Pan	Available for HCH units for cooling capability.

Table 6.3
Field Installed Accessories for Vertical Models

Field Installed Accessories	Description
Cone-Jet	The cone-jet allows the discharge air stream to be adjusted from a concentrated high velocity jet to a broadened air stream to cover a larger area. See page 22 for additional information.
Truncone	The truncone causes a broad discharge air stream covering a larger area than possible with the cone-jet. See page 22 for additional information.
One Way Louver	The one-way louver allows the discharge air stream to be adjusted in one direction. See page 22 for additional information.
Two Way Louver	The two-way louver allows the discharge air stream to be adjusted in two directions. See page 22 for additional information.

Table 6.4
Field Installed General Accessories

Field Installed Accessories	Description
Thermostat	Honeywell T4051A1003, 50-80°F range, 16A @ 115V, 8A @ 230V
Thermostat	Honeywell T451A3005, 44-86°F range, 9.8A @ 115V, 4.9A @ 230V
Thermostat	Johnson Controls T22BBC-1, 40-90°F range, Auto/Off/Fan switch, 10A @ 115V, 4.9A @ 230V
Explosion-proof Thermostat	Honeywell T6051B1006, 46-84° range, 10.2A @ 115V, 6.5A @ 230V
Aquastat	Aquastat, 10 amps @ 115V; 6 amps @ 230V; 100°-240°F range, SPDT, 10°F Diff. Fixed, Johnson A19D-AC-1
Thermostat Guard	Clear plastic locking guard with tumbler lock and two keys. Available only on thermostat Item Codes 23124, 23125 and 90348.
Pipe Hanger Adapter Kit	Allows unit heater to be suspended by threaded pipe instead of threaded rod. Two kits are required for V and VN models. Kits are not available for HSB-18 and HSB-24 models or Power-Throw™ models.
Manual Starter	Toggle switch starter with thermal overload protection for remote on/off control of unit fan operation. Available for power codes 01 and 02 only.
Step-Down Transformer	For supply voltages of 208V/60Hz/1ph and all non-explosion-proof 3 phase voltages of 208, 230, 460 and 575, certain Model Numbers require that a 115V/60Hz/1 phase Power Code 01 unit heater be used with a shipped loose accessory transformer. See page 23 for additional information.

Power Code Descriptions & Control Sequence

Table 7.1
Power Code Descriptions

Power Code	Supply Voltage	Motor Enclosure	Motor Type	Thermal Overload Protection	Motor Starter
01	115/60/1	Enclosed Air Over	①	Yes	N/A
04	200-208/60/3	Enclosed Air Over	Polyphase Induction	No	Field Supplied/Installed
05	230/460/60/3	Enclosed Air Over	Polyphase Induction	No	Field Supplied/Installed
06	115/60/1	Explosion-proof ②	Split Phase	Yes	N/A
09	230/460/60/3	Explosion-proof ②	Polyphase Induction	Yes	Field Supplied/Installed
10	575/60/3	Enclosed Air Over	Polyphase Induction	No	Field Supplied/Installed

① Motors are shaded pole for models HSB/HC 18-33 and V/VN 42-95. Models HSB/HC 47-340 and V/VN 139-333 are permanent split capacitor.

② Explosion-proof motors are suitable for Class I, Group D, Class II, Groups F and G, and Class III, Division 1 and 2 environments. Canadian Standard Association (CSA) requirements state that the explosion-proof units may not be used with a fluid temperature in excess of 329°F or pressures greater than 87 psig and still maintain their T3B temperature rating.

Class I, Group D motors are for operations in areas containing gasoline, petroleum, naphtha, benzene, butane, propane, alcohol, acetone, lacquer solvent or natural gas.

Class II, Group F motors are for operations in areas containing carbon black, coal or coke dust.

Class II, Group G motors are for operations in areas containing flour, starch or grain dust.

Class III motors are for operations in areas containing easily ignitable fibers and flyings.

Control Sequence

The following control sequence descriptions are typical for steam/hot water unit heaters:

Intermittent Fan Operation - Hot Coil

When a room thermostat calls for heat, the motor is energized. Hot water or steam is continuously supplied to the unit heater, even when the motor is not running. When the thermostat is satisfied, the motor is de-energized.

Continuous Fan Operation - Intermittent Hot/Cold Coil

When a room thermostat calls for heat, a valve is opened, allowing steam or hot water to enter the unit heater. When the thermostat is satisfied, the valve is closed. The fan runs continuously.

Intermittent Fan Operation - Intermittent Hot/Cold Coil

When a room thermostat calls for heat, the motor is energized. At the same time, a valve is opened allowing steam or hot water to enter the unit heater. An aquastat may be attached to the supply or return piping to prevent fan operation until the coil is adequately heated to avoid cold air delivery. When the thermostat is satisfied, the valve closes and the motor is de-energized.



Modine Breeze™ AccuSpec Sizing and Selection Program

The Modine Breeze AccuSpec is the fastest way to generate performance data based on actual job conditions. The Breeze AccuSpec program is a web-based sizing and selection program. The program provides a series on step-by-step questions that allow for the easy configuration of Modine products. After a model has been configured, the program can generate Submittal Schedules, Submittal Data including performance and dimensional drawings, and Specifications.

Pictures for Visual Selection

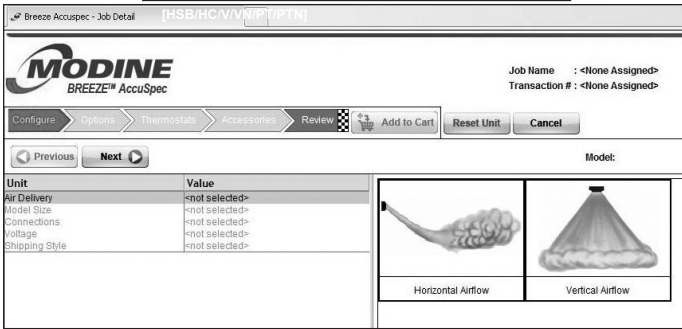

Capacities at Job Conditions

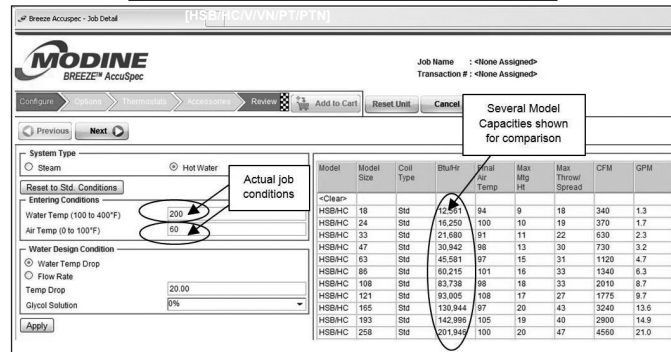

Submittal Schedules

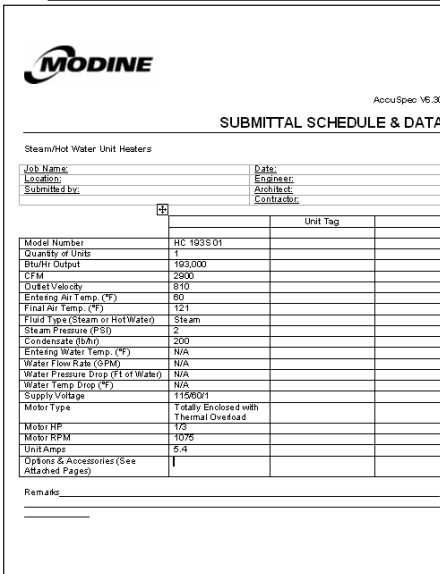

Unit Specific Dimensional Drawings

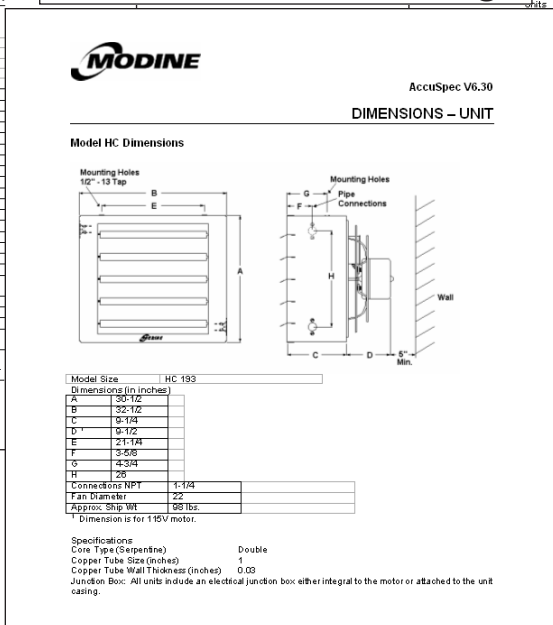

Job Specific Specifications

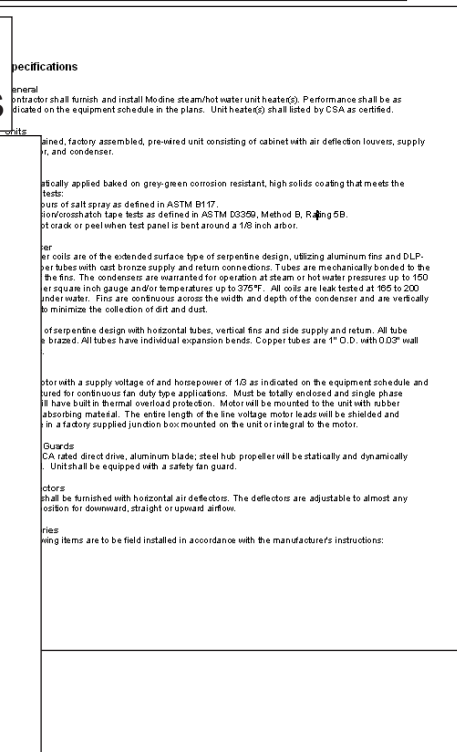

For access to the Breeze AccuSpec program, contact your local Modine sales representative.

Steam Conversion Tables

Table 9.1 and the formulas below are used to determine the heating capacity (Btu/hr) of a unit heater at a steam pressure and/or entering air temperature other than standard conditions of 2 lb. steam, 60°F entering air temperature.

Table 9.1
Steam Heating Capacity Conversion Factors

Unit Heater Type	Steam Pressure (PSIG)	Entering Air Temperature (°F)											
		-10	0	10	20	30	40	50	60	70	80	90	100
Horizontal Delivery	0	1.54	1.45	1.37	1.27	1.19	1.11	1.03	0.96	0.88	0.81	0.74	0.67
	2	1.59	1.50	1.41	1.32	1.24	1.16	1.08	1.00	0.93	0.85	0.78	0.71
	5	1.64	1.55	1.46	1.37	1.29	1.21	1.13	1.05	0.97	0.90	0.83	0.76
	10	1.73	1.64	1.55	1.46	1.38	1.29	1.21	1.13	1.06	0.98	0.91	0.84
	15	1.80	1.71	1.61	1.53	1.44	1.34	1.28	1.19	1.12	1.04	0.97	0.90
	20	1.86	1.77	1.68	1.58	1.50	1.42	1.33	1.25	1.17	1.10	1.02	0.95
	30	1.97	1.87	1.78	1.68	1.60	1.51	1.43	1.35	1.27	1.19	1.12	1.04
	40	2.06	1.96	1.86	1.77	1.68	1.60	1.51	1.43	1.35	1.27	1.19	1.12
	50	2.13	2.04	1.94	1.85	1.76	1.67	1.58	1.50	1.42	1.34	1.26	1.19
	60	2.20	2.09	2.00	1.90	1.81	1.73	1.64	1.56	1.47	1.39	1.31	1.24
	70	2.26	2.16	2.06	1.96	1.87	1.78	1.70	1.61	1.53	1.45	1.37	1.29
	75	2.28	2.18	2.09	1.99	1.90	1.81	1.72	1.64	1.55	1.47	1.40	1.32
	80	2.31	2.21	2.11	2.02	1.93	1.84	1.75	1.66	1.58	1.50	1.42	1.34
	90	2.36	2.26	2.16	2.06	1.97	1.88	1.79	1.71	1.62	1.54	1.46	1.38
	100	2.41	2.31	2.20	2.11	2.02	1.93	1.84	1.75	1.66	1.58	1.50	1.42
125	2.51	2.41	2.31	2.21	2.11	2.02	1.93	1.84	1.76	1.68	1.59	1.51	
150	2.60	2.50	2.40	2.30	2.20	2.11	2.02	1.93	1.84	1.76	1.67	1.59	
Vertical Delivery and Power-Throw	0	1.49	1.41	1.33	1.25	1.18	1.11	1.03	0.96	0.90	0.83	0.76	0.69
	2	1.52	1.45	1.37	1.29	1.22	1.15	1.07	1.00	0.93	0.86	0.80	0.73
	5	1.58	1.50	1.42	1.34	1.27	1.20	1.12	1.05	0.98	0.91	0.85	0.78
	10	1.64	1.57	1.49	1.41	1.34	1.27	1.19	1.12	1.05	0.98	0.91	0.85
	15	1.70	1.62	1.55	1.47	1.40	1.32	1.25	1.18	1.11	1.04	0.97	0.90
	20	1.75	1.67	1.60	1.52	1.45	1.37	1.30	1.23	1.16	1.09	1.02	0.96
	30	1.83	1.75	1.68	1.61	1.53	1.46	1.39	1.32	1.25	1.18	1.11	1.04
	40	1.90	1.82	1.75	1.68	1.61	1.53	1.46	1.39	1.32	1.25	1.18	1.11
	50	1.96	1.87	1.81	1.74	1.67	1.59	1.52	1.45	1.38	1.31	1.24	1.17
	60	2.02	1.94	1.87	1.79	1.72	1.64	1.57	1.50	1.43	1.36	1.29	1.22
	70	2.07	1.99	1.92	1.84	1.76	1.69	1.62	1.55	1.47	1.40	1.33	1.27
	75	2.10	2.02	1.94	1.86	1.79	1.71	1.64	1.57	1.49	1.42	1.36	1.29
	80	2.11	2.04	1.96	1.88	1.80	1.73	1.66	1.59	1.51	1.44	1.38	1.31
	90	2.15	2.08	2.00	1.92	1.84	1.77	1.69	1.62	1.55	1.48	1.41	1.34
	100	2.19	2.11	2.03	1.95	1.88	1.80	1.73	1.66	1.59	1.52	1.45	1.38
	125	2.27	2.19	2.11	1.99	1.91	1.88	1.81	1.74	1.67	1.60	1.53	1.46
	150	2.34	2.26	2.18	2.10	2.03	1.95	1.88	1.81	1.74	1.67	1.60	1.53
175	2.40	2.32	2.24	2.16	2.09	2.01	1.94	1.87	1.80	1.73	1.66	1.59	
200	2.45	2.37	2.29	2.22	2.14	2.07	1.99	1.92	1.85	1.78	1.71	1.64	
225	2.50	2.42	2.34	2.26	2.19	2.12	2.04	1.97	1.90	1.83	1.76	1.69	
250	2.54	2.46	2.38	2.31	2.23	2.16	2.09	2.01	1.94	1.87	1.80	1.73	

Applicable formulas (examples on page 14):

To find actual unit heater capacity when operated at non-standard (actual) conditions:

$$Btu_A = Btu_S \times \text{Heating Capacity Factor}$$

To select a heater capacity based on standard conditions to meet a heating capacity at non-standard (actual) conditions:

$$Btu_S = Btu_A \div \text{Heating Capacity Factor}$$

Where:

Btu_S = Capacity at standard conditions (2 lb. steam, 60°F entering air temperature) from Tables 12.1 through 13.2

Btu_A = Capacity at non-standard (actual) conditions



Steam Conversion Tables

Table 10.1 and the formulas below are used to determine the air temperature rise of a unit heater at a steam pressure and/or entering air temperature other than standard conditions of 2 lb. steam, 60°F entering air temperature.

Table 10.1
Air Temperature Rise Conversion Factors

Unit Heater Type	Steam Pressure (PSIG)	Entering Air Temperature (°F)											
		-10	0	10	20	30	40	50	60	70	80	90	100
Horizontal Delivery	0	1.33	1.28	1.24	1.17	1.12	1.07	1.01	0.96	0.90	0.84	0.78	0.72
	2	1.38	1.33	1.27	1.22	1.17	1.11	1.06	1.00	0.94	0.88	0.83	0.76
	5	1.43	1.38	1.33	1.27	1.21	1.16	1.11	1.05	1.00	0.93	0.88	0.82
	10	1.50	1.45	1.40	1.35	1.29	1.24	1.19	1.13	1.07	1.02	0.95	0.90
	15	1.56	1.51	1.46	1.42	1.36	1.31	1.24	1.19	1.14	1.08	1.02	0.97
	20	1.61	1.56	1.52	1.46	1.41	1.36	1.30	1.25	1.19	1.14	1.08	1.02
	30	1.70	1.65	1.61	1.55	1.51	1.46	1.40	1.35	1.29	1.24	1.18	1.12
	40	1.78	1.73	1.68	1.62	1.58	1.54	1.48	1.43	1.38	1.32	1.26	1.21
	50	1.84	1.79	1.74	1.69	1.65	1.60	1.55	1.50	1.45	1.39	1.33	1.28
	60	1.91	1.86	1.81	1.75	1.71	1.66	1.61	1.56	1.50	1.45	1.40	1.33
	70	1.95	1.91	1.86	1.81	1.76	1.71	1.66	1.61	1.56	1.51	1.45	1.39
	75	1.97	1.93	1.89	1.84	1.79	1.74	1.69	1.64	1.58	1.53	1.47	1.42
	80	2.00	1.95	1.91	1.86	1.82	1.76	1.72	1.66	1.61	1.56	1.49	1.44
	90	2.04	2.00	1.95	1.90	1.86	1.81	1.75	1.70	1.65	1.60	1.54	1.49
	100	2.08	2.04	1.99	1.95	1.89	1.85	1.79	1.75	1.69	1.64	1.59	1.53
125	2.17	2.13	2.09	2.04	1.99	1.94	1.89	1.84	1.79	1.74	1.68	1.63	
150	2.25	2.21	2.17	2.12	2.07	2.03	1.98	1.93	1.87	1.83	1.77	1.71	
Vertical Delivery and Power-Throw	0	1.36	1.31	1.25	1.19	1.13	1.08	1.02	0.96	0.90	0.84	0.78	0.72
	2	1.41	1.35	1.29	1.24	1.18	1.12	1.06	1.00	0.94	0.88	0.82	0.76
	5	1.46	1.40	1.35	1.29	1.23	1.17	1.12	1.06	1.00	0.94	0.88	0.82
	10	1.54	1.48	1.43	1.37	1.31	1.25	1.20	1.14	1.08	1.02	0.96	0.89
	15	1.61	1.55	1.49	1.44	1.38	1.32	1.26	1.20	1.14	1.09	1.02	0.97
	20	1.67	1.61	1.55	1.50	1.44	1.38	1.32	1.26	1.20	1.15	1.08	1.02
	30	1.77	1.71	1.65	1.60	1.54	1.48	1.42	1.36	1.30	1.25	1.18	1.12
	40	1.85	1.79	1.74	1.68	1.62	1.56	1.51	1.45	1.39	1.33	1.27	1.21
	50	1.92	1.86	1.81	1.75	1.69	1.64	1.58	1.52	1.46	1.40	1.34	1.28
	60	1.99	1.93	1.88	1.82	1.76	1.70	1.65	1.58	1.53	1.47	1.41	1.35
	70	2.05	1.99	1.94	1.88	1.82	1.76	1.70	1.65	1.59	1.53	1.47	1.41
	75	2.08	2.02	1.96	1.91	1.85	1.79	1.73	1.67	1.62	1.56	1.50	1.43
	80	2.10	2.04	1.99	1.93	1.87	1.81	1.75	1.70	1.64	1.58	1.52	1.46
	90	2.15	2.09	2.04	2.00	1.92	1.86	1.80	1.74	1.69	1.63	1.57	1.51
	100	2.19	2.14	2.08	2.02	1.97	1.91	1.85	1.79	1.73	1.67	1.61	1.55
	125	2.29	2.24	2.18	2.12	2.07	2.01	1.95	1.89	1.83	1.77	1.71	1.65
	150	2.39	2.33	2.27	2.22	2.16	2.10	2.04	1.99	1.93	1.87	1.81	1.75
175	2.46	2.41	2.35	2.29	2.24	2.18	2.12	2.06	2.00	1.94	1.88	1.82	
200	2.54	2.48	2.42	2.37	2.31	2.25	2.19	2.13	2.07	2.02	1.96	1.89	
225	2.60	2.54	2.49	2.43	2.37	2.32	2.26	2.20	2.14	2.08	2.02	1.96	
250	2.66	2.60	2.55	2.49	2.43	2.38	2.32	2.26	2.20	2.14	2.08	2.02	

Applicable formulas (examples on page 14):

To find actual air temperature rise of unit heater when operated at non-standard (actual) conditions:

$$ATR_A = (FAT_S - EAT_S) \times \text{Air Temperature Rise Factor}$$

To find actual final air temperature of unit heater when operated at non-standard (actual) conditions:

$$FAT_A = EAT_A + ATR_A$$

Where:

- EAT_S = Standard conditions entering air temperature (60°F)
- EAT_A = Non-standard (actual) entering air temperature
- FAT_S = Final air temperature at standard conditions from Tables 12.1 through 13.2
- FAT_A = Final air temperature at non-standard (actual) conditions
- ATR_A = Air temperature rise at non-standard (actual) conditions

PERFORMANCE DATA



Steam Conversion Tables

Table 11.1 is used to determine how steam pressures other than 2 lb. affect mounting height.

Table 11.1
Steam Unit Heater Mounting Height Correction Factors ① ②

Correction Factor	Steam Pressure, PSIG																		
	2	5	10	15	20	30	40	50	60	70	80	90	100	125	150	175	200	225	250
Correction Factor	1.00	0.97	0.94	0.92	0.89	0.86	0.84	0.82	0.80	0.79	0.77	0.76	0.76	0.74	0.72	0.71	0.70	0.69	0.68

① Factors are for use with entering air temperatures that range from 50° to 70°F.

② While all units are capable of operation on steam pressures greater than 30 lb., low outlet temperature models are ideally suited for steam pressures above 30 lb. when mounting height is critical.

Applicable formula (examples on page 14):

$$\text{Max. Mounting Height}_A = \text{Max. Mounting Height}_S \times \text{Correction Factor}$$

Where:

Max. Mounting Height_A = Maximum mounting height at actual conditions

Max. Mounting Height_S = Maximum mounting height at standard conditions

Table 11.2 is used to determine the rate of condensate production at steam pressures other than 2 lb.

Table 11.2
Properties of Steam

Gauge Pressure (PSIG)	Temp (°F)	Latent Heat (Btu/lb.)	Gauge Pressure (PSIG)	Temp (°F)	Latent Heat (Btu/lb.)	Gauge Pressure (PSIG)	Temp (°F)	Latent Heat (Btu/lb.)	Gauge Pressure (PSIG)	Temp (°F)	Latent Heat (Btu/lb.)
0	212.0	970.3	34	279.4	924.7	70	316.0	897.3	109	343.6	875.4
2	218.5	966.2	36	281.9	922.9	72	317.7	896.0	112	345.4	873.9
4	224.4	962.4	38	284.3	921.1	74	319.3	894.8	115	347.2	872.5
5	227.2	960.6	40	286.7	919.3	76	320.9	893.5	118	348.9	871.0
6	229.8	958.8	42	289.0	917.6	78	322.4	892.3	121	350.7	869.6
8	234.8	955.6	44	291.3	915.9	80	323.9	891.1	124	352.4	868.2
10	239.4	952.5	46	293.5	914.3	82	325.4	889.9	125	352.9	867.8
12	243.7	949.6	48	295.6	912.7	84	326.9	888.8	127	354.0	866.9
14	247.8	946.8	50	297.7	911.2	86	328.4	887.6	130	355.7	865.5
16	251.6	944.2	52	299.7	909.7	88	329.8	886.5	133	357.3	864.1
18	255.3	941.7	54	301.7	908.2	90	331.2	885.4	136	358.9	862.9
20	258.8	939.3	56	303.6	906.7	92	332.5	884.3	139	360.4	861.5
22	262.1	936.9	58	305.5	905.3	94	333.9	883.2	142	362.0	860.3
24	265.3	934.7	60	307.3	903.9	96	335.2	882.1	145	363.5	859.0
26	268.3	932.5	62	309.1	902.5	98	336.6	881.1	150	365.9	856.9
28	271.3	930.5	64	310.9	901.2	100	337.9	880.0	175	377.4	846.8
30	274.1	928.5	66	312.6	899.9	103	339.8	878.5	200	387.9	837.2
32	276.8	926.6	68	314.4	898.6	106	341.7	876.9	225	397.3	828.5
-	-	-	-	-	-	-	-	-	250	406.1	820.0

Applicable formula (examples on page 14):

$$\text{Condensate rate} = \text{Btu}_A \div \text{Latent Heat of Steam}$$

Where:

Btu_A = Capacity at actual operating conditions

PERFORMANCE DATA



Steam Performance Data - Standard Models

Table 12.1 - Performance Data for Standard Units at Standard Conditions of 2 lb. Steam and 60°F Entering Air High Motor Speed

Type	Model No.	Btu/hr	Sq. Ft. EDR	Air Data						Motor Data			
				Maximum Mounting Height (ft.) ①	Heat Throw or Spread @ Max. Height ①	CFM ②	Outlet Velocity (Fpm)	Final Air Temp. (°F)	Condensate lb/hr	Hp	Approx. RPM		
Horizontal Delivery	HSB/HC 18	18,000	75	8	17	340	625	107	19	1/60	1,550		
	HSB/HC 24	24,000	100	9	18	370	695	119	25	1/25	1,550		
	HSB/HC 33	33,000	138	10	21	630	690	108	34	1/25	1,550		
	HSB/HC 47	47,000	196	12	28	730	810	119	49	1/12	1,550		
	HSB/HC 63	63,000	263	14	29	1,120	690	111	65	1/12	1,550		
	HSB/HC 86	86,000	358	15	31	1,340	835	118	89	1/8	1,625		
	HSB/HC 108	108,000	450	17	31	2,010	790	109	112	1/8	1,625		
	HSB/HC 121	121,000	504	16	25	1,775	715	122	125	1/5	1,075		
	HSB/HC 165	165,000	688	19	40	3,240	880	106	171	1/3	1,075		
	HSB/HC 193	193,000	804	18	38	2,900	810	121	200	1/3	1,075		
	HSB/HC 258	258,000	1,075	19	44	4,560	750	111	267	1/2	1,075		
HSB/HC 290	290,000	1,208	20	46	4,590	765	117	300	1/2	1,075			
HSB/HC 340	340,000	1,417	20	46	5,130	735	120	352	1/2	1,075			
Power Throw™ ③	PT/PTN 279	279,000	1,163	16	100	5,460	2,165	111	289	1/2	1,075		
	PT/PTN 333	333,000	1,388	17	110	5,980	2,165	116	345	3/4	1,140		
	PT/PTN 385	385,000	1,604	17	115	7,680	1,860	110	398	1	1,140		
	PT/PTN 500	500,000	2,083	18	130	10,390	2,520	108	517	1 1/2	1,140		
	PT/PTN 610	610,000	2,542	20	140	11,750	2,315	112	631	1 1/2	1,140		
	PT 952	952,000	3,967	21	145	12,170	2,321	139	985	2	1,140		
Vertical Delivery ③	V/VN 42	42,000	175	11	15	17	11	950	825	103	43	1/30	1,050
	V/VN 59	59,000	246	14	19	21	14	1,155	1,005	111	61	1/30	1,050
	V/VN 78	78,000	325	15	20	23	15	1,590	1,065	109	81	1/15	1,050
	V/VN 95	95,000	396	15	20	23	15	1,665	1,120	118	98	1/15	1,050
	V/VN 139	139,000	579	18	24	27	18	2,660	1,285	112	144	1/6	1,075
	V/VN 161	161,000	671	20	27	30	20	2,945	1,420	115	167	1/3	1,075
	V/VN 193	193,000	804	22	30	33	22	3,500	1,690	116	200	1/3	1,075
	V/VN 212	212,000	883	22	30	33	22	3,610	1,740	120	219	1/3	1,075
	V/VN 247	247,000	1,029	26	34	39	26	4,820	1,910	111	256	1/2	1,075
	V/VN 279	279,000	1,163	30	37	45	30	5,460	2,165	111	289	1/2	1,075
	V/VN 333	333,000	1,388	30	37	45	30	5,980	2,165	116	345	3/4	1,140
	V/VN 385	385,000	1,604	30	36	45	30	7,680	1,860	110	398	1	1,140
	V/VN 500	500,000	2,083	37	44	56	37	10,390	2,520	108	517	1 1/2	1,140
V/VN 610	610,000	2,542	36	43	54	36	11,750	2,315	112	631	1 1/2	1,140	
V 952	952,000	3,967	37		56		12,170	2,321	139	985	2	1,140	

Table 12.2 - Performance Data for Standard Units at Standard Conditions of 2 lb. Steam and 60°F Entering Air Reduced Motor Speed ④

Type	Model No.	Btu/hr	Sq. Ft. EDR	Air Data						Motor Data	
				Maximum Mounting Height (ft.) ①	Heat Throw or Spread @ Max. Height ①	CFM ②	Outlet Velocity (Fpm)	Final Air Temp. (°F)	Condensate lb/hr	Hp	Approx. RPM
Horizontal Delivery	HSB/HC 18	14,000	58	8	10	220	415	118	14	1/60	1,000
	HSB/HC 24	18,000	75	9	11	230	440	131	19	1/25	1,000
	HSB/HC 33	25,000	104	10	13	395	440	118	26	1/25	1,000
	HSB/HC 47	38,000	158	12	17	450	515	137	39	1/12	1,000
	HSB/HC 63	47,000	195	14	17	685	430	122	49	1/12	1,000
	HSB/HC 86	64,000	265	15	19	825	525	131	66	1/8	1,000
	HSB/HC 108	81,000	340	17	19	1,255	500	119	84	1/8	1,000

① Horizontal units with horizontal louvers open 30° from vertical plane. Vertical types equipped with cone jet deflector, blades fully opened are shown in bold. Please see page 21 for additional outlet accessory performance data.

② Cfm for horizontal types is entering Cfm. Cfm for vertical and Power-Throw™ types is leaving Cfm.

③ V and PT models have copper tubes, VN and PTN models have 90/10 cupro-nickel tubes.

④ Requires Solid State Motor Speed Controller.

PERFORMANCE DATA



Steam Performance Data - Low Outlet Temperature Models

Table 13.1 - Performance Data for Low Outlet Temperature Units at Standard Conditions of 2 lb. Steam and 60°F Entering Air High Motor Speed

Type	Model No.	Btu/hr	Sq. Ft. EDR	Air Data						Motor Data			
				Maximum Mounting Height (ft.) ①	Heat Throw or Spread @ Max. Height ①		CFM ②	Outlet Velocity (Fpm)	Final Air Temp. (°F)	Condensate lb/hr	Hp	Approx. RPM	
Horizontal Delivery	HSB/HC 18L	15,900	66	9	20		364	655	100	16	1/60	1,550	
	HSB/HC 24L	19,300	80	11	21		435	795	100	20	1/25	1,550	
	HSB/HC 33L	29,500	123	12	24		695	745	99	31	1/25	1,550	
	HSB/HC 47L	32,000	133	14	32		855	910	94	33	1/12	1,550	
	HSB/HC 63L	52,500	219	16	33		1,170	710	101	54	1/12	1,550	
	HSB/HC 86L	61,500	256	17	36		1,510	910	97	64	1/8	1,625	
	HSB/HC 108L	86,500	360	19	36		2,150	825	97	90	1/8	1,625	
	HSB/HC 121L	88,000	367	18	29		2,070	800	98	91	1/5	1,075	
	HSB/HC 165L	143,000	596	21	45		3,480	930	97	148	1/3	1,075	
	HSB/HC 258L	190,000	792	22	51		4,655	750	98	197	1/2	1,075	
HSB/HC 290L	207,000	863	23	53		5,040	805	94	214	1/2	1,075		
HSB/HC 340L	255,000	1,063	23	53		5,575	775	102	264	1/2	1,075		
Power Throw™ ③	PT/PTN 610L	470,000	1,958	22	154		2,400	2,445	97	486	1-1/2	1,140	
Vertical Delivery ③	V/VN 42L	33,000	138	13	17	20	13	960	835	94	34	1/30	1,050
	V/VN 59L	44,000	183	16	22	24	16	1,190	1,035	96	45	1/30	1,050
	V/VN 78L	62,000	258	19	26	29	19	1,740	1,070	95	65	1/15	1,050
	V/VN 95L	71,000	296	19	26	29	19	1,760	1,180	99	73	1/15	1,050
	V/VN 139L	103,000	429	23	31	35	23	2,860	1,380	95	106	1/6	1,075
	V/VN 161L	127,000	529	26	35	39	26	3,400	1,640	96	132	1/3	1,075
	V/VN 193L	149,000	621	27	36	41	27	3,710	1,790	99	154	1/3	1,075
	V/VN 212L	163,000	679	27	36	41	27	3,830	1,845	102	169	1/3	1,075
	V/VN 247L	190,000	792	32	42	48	32	5,110	2,030	96	197	1/2	1,075
	V/VN 279L	215,000	896	36	45	54	36	5,790	2,300	96	222	1/2	1,075
	V/VN 333L	256,000	1,067	36	45	54	36	6,340	2,300	100	265	3/4	1,140
	V/VN 385L	296,000	1,233	36	43	54	36	8,140	1,970	95	307	1	1,140
	V/VN 500L	385,000	1,604	45	54	68	45	11,000	2,670	94	400	1-1/2	1,140
V/VN 610L	470,000	1,958	44	52	66	44	12,400	2,445	97	485	1-1/2	1,140	
V 952L	733,000	3,055	45	-	68	-	12,940	2,450	115	759	2	1,140	

Table 13.2 - Performance Data for Low Outlet Temperature Units at Standard Conditions of 2 lb. Steam and 60°F Entering Air Reduced Motor Speed ④

Type	Model No.	Btu/hr	Sq. Ft. EDR	Air Data						Motor Data		
				Maximum Mounting Height (ft.) ①	Heat Throw or Spread @ Max. Height ①		CFM ②	Outlet Velocity (Fpm)	Final Air Temp. (°F)	Condensate lb/hr	Hp	Approx. RPM
Horizontal Delivery	HSB/HC 18L	12,000	51	9	12		230	425	108	12	1/60	1,000
	HSB/HC 24L	14,400	60	11	13		265	490	109	15	1/25	1,000
	HSB/HC 33L	22,000	92	12	14		430	470	107	23	1/25	1,000
	HSB/HC 47L	24,300	101	14	19		540	580	101	25	1/12	1,000
	HSB/HC 63L	39,500	164	16	20		725	445	109	41	1/12	1,000
	HSB/HC 86L	46,000	192	17	22		925	565	105	48	1/8	1,000
HSB/HC 108L	65,000	270	19	22		1,330	520	104	67	1/8	1,000	

① Horizontal units with horizontal louvers open 30° from vertical plane. Vertical types equipped with cone jet deflector, blades fully opened are shown in bold. Please see page 21 for additional outlet accessory performance data.

② Cfm for horizontal types is entering Cfm. Cfm for vertical and Power-Throw™ types is leaving Cfm.

③ V and PT models have copper tubes, VN and PTN models have 90/10 cupro-nickel tubes.

④ Requires Solid State Motor Speed Controller.

Steam Conversion Tables - Example Calculations

Conversion factor example #1:

For an HSB340S operating at 30 lb. steam and 50°F entering air temperature, determine the following:

- Capacity (Btu/hr)
- Final air temperature (°F)
- Condensate (lb./hr)
- Maximum mounting height

Solution:

The factors/data necessary to solve this problem are as follows:

- Steam heating capacity conversion factor for 30 lb. steam and 50°F entering air is 1.43, from Table 9.1.
- Air temperature rise conversion factor is 1.40, from Table 10.1.
- The latent heat of steam at 30 lb. is 928.5 Btu/lb., from Table 11.2.
- The mounting height correction factor is 0.86, from Table 11.1.
- The standard rated capacity of an HSB 340 is 340,000 Btu/hr, from Table 12.1.
- The final air temperature of an HSB 340 at standard conditions is 120°F, from Table 12.1.
- The maximum mounting height at standard conditions is 20 feet, from Table 12.1.

$$\text{Btu}_A = \text{Btu}_S \times \text{Heating Capacity Factor} = 340,000 \times 1.43 = \underline{486,200 \text{ Btu/hr}}$$

$$\text{ATR}_A = (\text{FAT}_S - \text{EAT}_S) \times \text{Air Temp Rise Factor} = (120^\circ\text{F} - 60^\circ\text{F}) \times 1.40 = 84^\circ\text{F}$$
$$\text{FAT}_A = \text{EAT}_A + \text{ATR}_A = 50^\circ\text{F} + 84^\circ\text{F} = \underline{134^\circ\text{F}}$$

$$\text{Condensate rate} = \text{Btu}_A \div \text{Latent Heat of Steam} = 486,200 \div 928.5 = \underline{523.6 \text{ lb./hr}}$$

$$\text{Max. Mounting Height}_A = \text{Max. Mounting Height}_S \times \text{Correction Factor} = 20 \text{ feet} \times 0.86 = \underline{17.2 \text{ feet}}$$

Conversion factor example #2:

Which vertical unit heater model is required to deliver 155,500 Btu/hr at 20 lb. steam and 60°F entering air temperature. What will be the actual capacity and rate of condensate production for the selected unit?

Solution:

The factors/data necessary to solve this problem are as follows:

- Steam heating capacity conversion factor for 20 lb. steam and 60°F entering air is 1.23, from Table 9.1.
- The latent heat of steam at 20 lb. is 939.3 Btu/lb. from Table 11.2.

$$\text{Btu}_S = \text{Btu}_A \div \text{Heating Capacity Factor} = 155,500 \div 1.23 = 126,423 \text{ Btu/hr (at standard conditions)}$$

From Table 13.1, a V 139 model meets the requirement with a rated capacity of 139,000 Btu/hr at standard conditions.

$$\text{The capacity of the V 139 at actual conditions will be } \text{Btu}_A = \text{Btu}_S \times \text{Heating Capacity Factor} = 139,000 \times 1.23 = \underline{170,970 \text{ Btu/hr.}}$$

$$\text{Condensate rate} = \text{Btu}_A \div \text{Latent Heat of Steam} = 170,970 \div 939.3 = \underline{182.0 \text{ lb./hr.}}$$

Alternate Solution:

Low Outlet Temperature models are normally recommended for steam pressures above 30 lb. However, the use of these models with steam pressure less than 30 lb. is acceptable.

Based on the example above, a V 161L model, from Table 13.1, meets the requirement with a rated capacity of 127,000 Btu/hr at standard conditions.

$$\text{The capacity of the V 161L at actual conditions will be } \text{Btu}_A = \text{Btu}_S \times \text{Heating Capacity Factor} = 127,000 \times 1.23 = \underline{156,210 \text{ Btu/hr.}}$$

$$\text{Condensate rate} = \text{Btu}_A \div \text{Latent Heat of Steam} = 156,210 \div 939.3 = \underline{166.3 \text{ lb./hr.}}$$



Hot Water Conversion Tables

Table 15.1 and the formulas below are used to determine the heating capacity (Btu/hr) of a unit heater at a water temperature and/or entering air temperature other than standard conditions of 200° entering water temperature, 60° entering air temperature.

Table 15.1
Hot Water Heating Capacity Conversion Factors

Entering Water Temp. (°F)	Entering Air Temperature (°F)										
	0	10	20	30	40	50	60	70	80	90	100
60	0.462	0.380	0.300	0.222	0.146	0.072	0	0	0	0	0
70	0.539	0.456	0.375	0.296	0.219	0.145	0.071	0	0	0	0
80	0.615	0.531	0.450	0.370	0.293	0.217	0.143	0.071	0	0	0
90	0.692	0.607	0.524	0.444	0.366	0.289	0.214	0.141	0.070	0	0
100	0.769	0.683	0.599	0.518	0.439	0.361	0.286	0.212	0.140	0.069	0
110	0.846	0.759	0.674	0.592	0.512	0.434	0.357	0.283	0.210	0.138	0.068
120	0.923	0.835	0.749	0.666	0.585	0.506	0.429	0.353	0.279	0.207	0.137
130	1.000	0.911	0.824	0.740	0.658	0.578	0.500	0.424	0.349	0.276	0.205
140	1.077	0.987	0.899	0.814	0.731	0.651	0.571	0.494	0.419	0.345	0.273
150	1.154	1.063	0.974	0.888	0.805	0.723	0.643	0.565	0.489	0.414	0.342
160	1.231	1.139	1.049	0.962	0.878	0.795	0.714	0.636	0.559	0.483	0.410
170	1.308	1.215	1.124	1.036	0.950	0.867	0.786	0.706	0.629	0.552	0.478
180	1.385	1.291	1.199	1.110	1.024	0.940	0.857	0.777	0.699	0.621	0.547
190	1.462	1.367	1.274	1.184	1.097	1.012	0.929	0.848	0.768	0.690	0.615
200	1.539	1.443	1.349	1.258	1.170	1.084	1.000	0.918	0.838	0.759	0.684
210	1.615	1.519	1.424	1.332	1.243	1.157	1.071	0.989	0.908	0.828	0.752
220	1.692	1.594	1.499	1.406	1.312	1.229	1.143	1.060	0.978	0.897	0.820
230	1.769	1.670	1.573	1.480	1.390	1.301	1.214	1.130	1.048	0.966	0.889
240	1.846	1.746	1.649	1.554	1.463	1.373	1.286	1.201	1.118	1.035	0.957
250	1.923	1.822	1.723	1.628	1.536	1.446	1.357	1.272	1.188	1.104	1.025
260	2.000	1.898	1.798	1.702	1.609	1.518	1.429	1.342	1.257	1.173	1.094
270	2.077	1.974	1.873	1.776	1.682	1.590	1.500	1.413	1.327	1.242	1.162
280	2.154	2.050	1.948	1.850	1.755	1.663	1.571	1.483	1.397	1.311	1.230
290	2.231	2.126	2.023	1.924	1.829	1.734	1.643	1.554	1.467	1.380	1.300
300	2.308	2.202	2.098	1.998	1.902	1.807	1.714	1.625	1.537	1.449	1.367
310	2.385	2.278	2.173	2.072	1.974	1.879	1.786	1.695	1.607	1.518	1.436
320	2.462	2.354	2.248	2.146	2.048	1.952	1.857	1.766	1.677	1.587	1.504
330	2.539	2.430	2.323	2.220	2.121	2.024	1.929	1.837	1.746	1.656	1.572
340	2.615	2.506	2.398	2.294	2.194	2.096	2.000	1.907	1.816	1.725	1.641
350	2.692	2.581	2.473	2.368	2.267	2.168	2.071	1.978	1.886	1.794	1.709
360	2.769	2.657	2.548	2.442	2.340	2.241	2.143	2.049	1.956	1.863	1.778
370	2.846	2.733	2.622	2.516	2.413	2.313	2.214	2.119	2.026	1.932	1.846
380	2.923	2.809	2.697	2.590	2.486	2.385	2.286	2.190	2.096	2.001	1.914
390	3.000	2.885	2.772	2.664	2.560	2.458	2.357	2.261	2.165	2.070	1.983
400	3.077	2.961	2.847	2.738	2.633	2.530	2.429	2.331	2.235	2.139	2.051

Applicable formulas (examples on page 21):

To find actual unit heater capacity when operated at non-standard (actual) conditions:

Btu_A = Btu_S x Heating Capacity Factor

To select a heater capacity based on standard conditions to meet a heating capacity at non-standard (actual) conditions:

Btu_S = Btu_A ÷ Heating Capacity Factor

Where:

Btu_S = Capacity at standard conditions (200°F entering water temperature, 60°F entering air temperature) from Tables 18.1 through 19.2

Btu_A = Capacity at non-standard (actual) conditions



Hot Water Conversion Tables

Table 16.1 - Minimum Water Flow and Water Volume (gallons) ①

TYPE	Model	Min. GPM	Max. GPM	Coil Volume (gals)	Type	Model	Min. GPM	Max. GPM	Coil Volume (gals)	Type	Model	Min. GPM	Max. GPM	Coil Volume (gals)	Type	Model	Min. GPM	Max. GPM	Coil Volume (gals)
HORIZONTAL DELIVERY HSB/HC	18	0.25	5	0.13	HORIZONTAL DELIVERY HCH	22	0.80	10	0.30	POWER-THROW PT/PTN	279	4.50	60	0.97	VERTICAL DELIVERY VVN	42	0.50	10	0.15
	24	0.25	5	0.13		39	1.40	18	0.50		333	4.50	100	1.24		59	0.75	15	0.23
	33	0.40	10	0.41		67	2.60	31	0.77		385	4.50	100	1.24		78	1.00	20	0.31
	47	0.40	10	0.41		104	4.10	48	1.10		500	6.00	100	1.66		95	1.25	25	0.38
	63	0.50	20	0.66		170	6.80	77	1.80		610	6.00	100	1.98		139	1.00	30	0.43
	86	0.50	20	0.66		195	8.00	88	2.14		952	14.00	200	6.50		161	1.25	40	0.54
	108	0.50	30	0.98												193	1.50	50	0.65
	121	0.50	30	0.98												212	2.00	60	0.86
	165	2.00	30	1.35												247	2.00	60	0.86
	193	2.00	50	1.45												279	2.25	75	0.97
	258	2.50	70	2.20												333	2.25	75	1.24
	290	2.50	70	2.20												385	2.25	75	1.24
	340	2.50	70	2.50												500	3.00	100	1.66
																610	6.00	100	1.98
												952	14.00	200	6.50				

① Water flow and water volume is the same for standard coils and low-outlet temperature coils

Table 16.2 - Ethylene Glycol Correction Factors ②

Table 16.2 is used to determine how glycol solutions affect heater capacity. These factors should be applied to the heater capacity at actual entering water and air temperature conditions.

Solution Temperature (°F)	Ethylene Glycol Solution %						
	20%	30%	40%	50%	60%	70%	80%
60	0.99	0.96	0.93	0.89	0.85	0.81	0.76
100	0.99	0.96	0.93	0.89	0.85	0.81	0.76
150	0.99	0.96	0.94	0.90	0.87	0.83	0.78
200	0.99	0.96	0.94	0.92	0.88	0.85	0.81
250	0.98	0.96	0.94	0.92	0.89	0.86	0.82
300	0.98	0.95	0.95	0.92	0.90	0.87	0.83
350	0.98	0.95	0.95	0.93	0.91	0.88	0.84
400	0.97	0.95	0.95	0.93	0.92	0.89	0.85

② For Propylene Glycol solution correction factor, multiply Ethylene Glycol correction factor by 0.95.

Applicable formulas (examples on page 20):

To find actual unit heater capacity when operated with glycol solution:

$$Btu_{AG} = Btu_S \text{ (or } Btu_A) \times \text{Glycol Correction Factor}$$

To select a heater capacity based on standard conditions to meet a heating capacity with a glycol solution:

$$Btu_S \text{ (or } Btu_A) = Btu_{AG} \div \text{Glycol Correction Factor}$$

Where:

Btu_S = Capacity at standard conditions (200°F entering water temperature, 60°F entering air temperature) from Tables 18.1 through 19.2

Btu_A = Capacity at non-standard (actual) conditions

Btu_{AG} = Capacity with glycol solution

Table 16.3 - Hot Water Unit Heater Mounting Height Correction Factors ③

Table 16.3 is used to determine how hot water temperatures other than 200°F affect mounting height.

Entering Water Temperature, °F	Correction Factor	Entering Water Temperature, °F	Correction Factor	Entering Water Temperature, °F	Correction Factor
140	1.33	230	0.91	320	0.74
150	1.25	240	0.89	330	0.72
160	1.19	250	0.86	340	0.71
170	1.13	260	0.84	350	0.70
180	1.08	270	0.82	360	0.69
190	1.04	280	0.80	370	0.67
200	1.00	290	0.78	380	0.66
210	0.97	300	0.77	390	0.65
220	0.94	310	0.75	400	0.64

③ Factors are for use with entering air temperatures that range from 50° to 70°F

Applicable formula (examples on page 20):

$$\text{Max. Mounting Height}_A = \text{Max. Mounting Height}_S \times \text{Correction Factor}$$

Where:

$\text{Max. Mounting Height}_A$ = Maximum mounting height at actual conditions

$\text{Max. Mounting Height}_S$ = Maximum mounting height at standard conditions

Hot Water Conversion Tables - Miscellaneous Formulas

Table 17.1 is used to determine how water temperature drop affects heater capacity in Btu, water flow rate in GPM and pressure drop in feet of water. These factors should be applied to the values at actual entering water and air temperature conditions.

Table 17.1
Correction Factors for Varying Water Temperature Drop ①

	Water Temperature Drop, °F											
	5	10	15	20	25	30	35	40	45	50	55	60
Btu Correction Factor	1.23	1.13	1.06	1.00	0.95	0.90	0.86	0.82	0.78	0.72	0.69	0.67
GPM Correction Factor	4.64	2.21	1.40	1.00	0.76	0.61	0.50	0.42	0.36	0.30	0.26	0.23
WPD Correction Factor	17.24	4.32	1.85	1.00	0.61	0.41	0.30	0.22	0.18	0.14	0.12	0.11

① Water temperature drop correction factors valid only for standard 200°F entering water and 60°F air temperature conditions.

Applicable formulas (examples on page 21):

To find actual unit heater capacity or flow rate or water pressure drop when operated at non-standard (actual) conditions:

$$\mathbf{Btu_A = Btu_S \times Btu \text{ Correction Factor}}$$

$$\mathbf{GPM_A = GPM_S \times GPM \text{ Correction Factor}}$$

$$\mathbf{WPD_A = WPD_S \times WPD \text{ Correction Factor}}$$

To select a heater capacity based on standard conditions to meet a heating capacity at non-standard (actual) conditions:

$$\mathbf{Btu_S = Btu_A \div Btu \text{ Correction Factor}}$$

Where:

- Btu_S = Capacity at standard conditions (200°F entering water temperature, 60°F entering air temperature) from Tables 18.1 through 19.2
- Btu_A = Capacity at non-standard (actual) conditions
- GPM_S = Flow rate at standard conditions (200°F entering water temperature, 60°F entering air temperature) from Tables 18.1 through 19.2
- GPM_A = Flow rate at non-standard (actual) conditions
- WPD_S = Water pressure drop at standard conditions (200°F entering water temperature, 60°F entering air temperature) from Tables 18.1 through 19.2
- WPD_A = Water pressure drop at non-standard (actual) conditions

Other miscellaneous useful formulas:

$$\mathbf{FAT_A = EAT_A + [(460 + EAT_A) \times (Btu_A) \div (573 \times Cfm_S)]} \quad \text{for HSB and HC units only}$$

$$\mathbf{FAT_A = EAT_A + [(460 + EAT_A) \div ((573 \times Cfm_S \div Btu_A) - 1)]} \quad \text{for V/VN and PT/PTN units only}$$

$$\mathbf{WTD_A = Btu_A \div (480 \times GPM_A)}$$

Where:

- EAT_A = Entering air temperature at actual conditions
- FAT_A = Final air temperature at actual conditions
- Btu_A = Capacity at actual conditions
- Cfm_S = Unit airflow as found in Tables 18.1 through 19.2
- GPM_A = Water flow rate at actual conditions in GPM
- WTD_A = Water temperature drop at actual conditions



Hot Water Performance Data - Standard Models

Table 18.1 - Performance Data for Standard Units at Standard Conditions of 200°F Entering Water and 60°F Entering Air High Motor Speed

Type	Model No.	Btu/hr	Water Data			Air Data					Motor Data			
			GPM	Pressure Drop (Ft. of Water)	Min/Max GPM	Maximum Mounting Height (ft.) ^①	Heat Throw or Spread @ Max. Height ^①	CFM ^②	Outlet Velocity (Fpm)	Final Air Temp. (°F)	Hp	Approx. RPM		
Horizontal Delivery	HSB/HC 18	12,600	1.3	0.5	0.3 / 5.0	9	18	340	615	93	1/60	1,550		
	HSB/HC 24	16,200	1.7	0.8	0.3 / 5.0	10	19	370	675	100	1/25	1,550		
	HSB/HC 33	21,700	2.3	0.2	0.4 / 10.0	11	23	630	675	91	1/25	1,550		
	HSB/HC 47	30,900	3.2	0.4	0.4 / 10.0	13	30	730	785	98	1/12	1,550		
	HSB/HC 63	45,600	4.7	0.6	0.5 / 20.0	15	31	1,120	680	97	1/12	1,550		
	HSB/HC 86	60,200	6.3	1.0	0.5 / 20.0	16	33	1,340	820	101	1/8	1,625		
	HSB/HC 108	83,700	8.7	2.8	0.5 / 30.0	18	33	2,010	775	98	1/8	1,625		
	HSB/HC 121	93,000	9.7	3.3	0.7 / 30.0	17	27	1,775	700	107	1/5	1,075		
	HSB/HC 165	130,900	13.6	8.6	2.0 / 30.0	20	43	3,240	870	96	1/3	1,075		
	HSB/HC 193	143,000	14.9	1.4	2.0 / 50.0	19	41	2,900	790	105	1/3	1,075		
	HSB/HC 258	201,900	21.0	5.7	2.5 / 70.0	20	47	4,560	740	100	1/2	1,075		
HSB/HC 290	228,600	23.8	7.1	2.5 / 70.0	22	50	4,590	750	105	1/2	1,075			
HSB/HC 340	271,100	28.2	11.3	2.8 / 70.0	22	50	5,130	720	108	1/2	1,075			
Power Throw™ ^③	PT/PTN 279	192,300	20.0	0.2	4.5 / 60.0	17	108	5,460	2,165	94	1/2	1,075		
	PT/PTN 333	238,500	24.8	0.4	4.5 / 100.0	18	117	5,980	2,165	99	3/4	1,140		
	PT/PTN 385	276,100	28.8	0.6	4.5 / 100.0	18	124	7,680	1,860	95	1	1,140		
	PT/PTN 500	358,000	37.3	0.5	6.0 / 100.0	19	138	10,390	2,520	93	1-1/2	1,140		
	PT/PTN 610	450,400	46.9	1.0	6.0 / 100.0	22	151	11,750	2,315	97	1-1/2	1,140		
	PT 952	721,600	75.2	1.1	14.0 / 200.0	23	150	12,166	2,321	120	2	1,140		
Vertical Delivery ^③	V/VN 42	30,100	3.1	0.6	0.5 / 10.0	12	16	18	12	950	825	90	1/30	1,050
	V/VN 59	42,600	4.4	0.5	0.8 / 15.0	15	20	22	15	1,155	1,005	96	1/30	1,050
	V/VN 78	57,000	5.9	0.5	1.0 / 20.0	16	22	24	16	1,590	1,065	95	1/15	1,050
	V/VN 95	69,300	7.2	0.5	1.3 / 25.0	16	22	24	16	1,665	1,120	101	1/15	1,050
	V/VN 139	106,600	11.1	2.6	1.0 / 30.0	19	26	29	19	2,660	1,285	99	1/6	1,075
	V/VN 161	123,200	12.8	2.2	1.3 / 40.0	21	29	32	22	2,945	1,420	101	1/3	1,075
	V/VN 193	147,200	15.3	2.2	1.5 / 50.0	23	32	35	24	3,500	1,690	101	1/3	1,075
	V/VN 212	161,700	16.8	1.5	2.0 / 60.0	23	32	35	24	3,610	1,740	104	1/3	1,075
	V/VN 247	188,700	19.7	2.1	2.0 / 60.0	28	37	41	28	4,820	1,910	98	1/2	1,075
	V/VN 279	212,600	22.2	2.1	2.3 / 75.0	32	40	48	32	5,460	2,165	98	1/2	1,075
	V/VN 333	260,100	27.1	3.8	2.8 / 75.0	32	40	48	32	5,980	2,165	102	3/4	1,140
	V/VN 385	302,100	31.5	5.0	3.3 / 75.0	32	39	48	32	7,680	1,860	98	1	1,140
	V/VN 500	391,700	40.8	4.8	3.0 / 100.0	39	47	59	40	10,390	2,520	96	1-1/2	1,140
V/VN 610	450,400	46.9	1.0	6.0 / 100.0	38	46	57	39	11,750	2,315	97	1-1/2	1,140	
V 952	721,600	75.2	1.1	14.0 / 200.0	39	-	59	-	12,166	2,321	120	2	1,140	

Table 18.2 - Performance Data for Standard Units at Standard Conditions of 200°F Entering Water and 60°F Entering Air Reduced Motor Speeds^④

Type	Model No.	Btu/hr	Water Data			Air Data				Motor Data	
			GPM	Pressure Drop (Ft. of Water)	Maximum Mounting Height (ft.) ^①	Heat Throw or Spread @ Max. Height ^①	CFM ^②	Outlet Velocity (Fpm)	Final Air Temp. (°F)	Hp	Approx. RPM
Horizontal Delivery	HSB/HC 18	9,900	1.3	0.5	9	11	220	400	101	1/60	1,000
	HSB/HC 24	12,400	1.7	0.8	10	12	230	425	109	1/25	1,000
	HSB/HC 33	16,700	2.3	0.2	11	14	395	430	98	1/25	1,000
	HSB/HC 47	23,600	3.2	0.4	13	18	450	490	107	1/12	1,000
	HSB/HC 63	34,600	4.7	0.6	15	18	685	420	106	1/12	1,000
	HSB/HC 86	45,900	6.3	1.0	16	20	825	515	110	1/8	1,000
	HSB/HC 108	64,300	8.7	2.8	18	20	1,255	490	106	1/8	1,000

① Horizontal units with horizontal louvers open 30° from vertical plane. Vertical types equipped with cone jet deflector, blades fully opened are shown in bold. Please see page 21 for additional outlet accessory performance data.

② Cfm for horizontal types is entering Cfm. Cfm for vertical and Power-Throw™ types is leaving Cfm.

③ V and PT models have copper tubes, VN and PTN models have 90/10 cupro-nickel tubes.

④ Requires Solid State Motor Speed Controller.

PERFORMANCE DATA



Hot Water Performance Data - Low Outlet Temperature Models

Table 19.1 - Performance Data for Low Outlet Temperature Units at Standard Conditions of 200°F Entering Water and 60°F Entering Air – High Motor Speed

Type	Model No.	Btu/hr	Water Data			Air Data					Motor Data			
			GPM	Pressure Drop (Ft. of Water)	Min/Max GPM	Maximum Mounting Height (ft.) ^①	Heat Throw or Spread @ Max. Height ^①	CFM ^②	Outlet Velocity (Fpm)	Final Air Temp. (°F)	Hp	Approx. RPM		
Horizontal Delivery	HSB/HC 18L	11,300	1.2	0.4	0.3 / 5.0	10	21	364	650	88	1/60	1,550		
	HSB/HC 24L	13,700	1.4	0.6	0.3 / 5.0	12	22	435	775	88	1/25	1,550		
	HSB/HC 33L	19,300	2.0	0.2	0.4 / 10.0	13	26	695	730	85	1/25	1,550		
	HSB/HC 47L	21,100	2.2	0.2	0.4 / 10.0	15	34	855	890	82	1/12	1,550		
	HSB/HC 63L	37,900	4.0	0.4	0.5 / 20.0	17	35	1,170	695	89	1/12	1,550		
	HSB/HC 86L	44,600	4.6	0.6	0.5 / 20.0	18	38	1,510	890	87	1/8	1,625		
	HSB/HC 108L	66,100	6.9	1.8	0.8 / 30.0	20	38	2,150	815	88	1/8	1,625		
	HSB/HC 121L	66,700	6.9	1.9	0.8 / 30.0	19	31	2,070	785	89	1/5	1,075		
	HSB/HC 165L	113,200	11.8	6.6	2.0 / 30.0	23	48	3,480	920	89	1/3	1,075		
	HSB/HC 258L	147,400	15.4	3.2	2.5 / 70.0	23	54	4,655	735	89	1/2	1,075		
HSB/HC 290L	161,100	16.8	3.7	2.5 / 70.0	25	57	5,040	800	89	1/2	1,075			
HSB/HC 340L	200,900	20.9	6.6	2.5 / 70.0	25	57	5,575	760	93	1/2	1,075			
Power Throw™ ^③	PT/PTN 610L	344,900	35.9	0.6	6.0 / 100.0	24	158	12,400	2,445	86	1 1/2	1,140		
Vertical Delivery ^③	V/VN 42L	23,000	2.4	0.4	0.5 / 10.0	14	18	21	14	960	835	83	1/30	1,050
	V/VN 59L	32,600	3.4	0.3	0.8 / 15.0	17	23	25	17	1,190	1,035	86	1/30	1,050
	V/VN 78L	43,600	4.5	0.3	1.0 / 20.0	20	28	31	21	1,740	1,170	84	1/15	1,050
	V/VN 95L	53,100	5.5	0.3	1.3 / 25.0	20	28	31	21	1,760	1,180	89	1/15	1,050
	V/VN 139L	81,200	8.5	1.6	1.0 / 30.0	24	33	37	25	2,860	1,380	87	1/6	1,075
	V/VN 161L	93,900	9.8	1.3	1.3 / 40.0	28	37	41	28	3,400	1,640	86	1/3	1,075
	V/VN 193L	112,500	11.7	1.3	1.5 / 50.0	29	38	43	29	3,710	1,790	89	1/3	1,075
	V/VN 212L	123,400	12.9	0.9	2.0 / 60.0	29	38	43	29	3,830	1,845	91	1/3	1,075
	V/VN 247L	143,600	15.0	1.2	2.0 / 60.0	34	45	51	35	5,110	2,030	87	1/2	1,075
	V/VN 279L	162,200	16.9	1.2	2.3 / 75.0	38	48	57	39	5,790	2,300	87	1/2	1,075
	V/VN 333L	198,300	20.7	2.3	2.3 / 75.0	38	48	57	39	6,340	2,300	90	3/4	1,140
	V/VN 385L	229,100	23.9	3.0	2.3 / 75.0	38	46	57	49	8,140	1,970	87	1	1,140
V/VN 500L	295,000	30.7	2.8	3.0 / 100.0	48	57	72	49	11,000	2,670	85	1 1/2	1,140	
V/VN 610L	344,900	35.9	0.6	6.0 / 100.0	47	55	70	48	12,400	2,445	86	1 1/2	1,140	
V 952L	546,700	56.9	0.7	14.0 / 100.0	48		72		12,800	2,440	102	2	1,140	

Table 19.2 - Performance Data for Low Outlet Temperature Units at Standard Conditions of 200°F Entering Water and 60°F Entering Air – Reduced Motor Speeds^④

Type	Model No.	Btu/hr	Water Data			Air Data				Motor Data	
			GPM	Pressure Drop (Ft. of Water)	Maximum Mounting Height (ft.) ^①	Heat Throw or Spread @ Max. Height ^①	CFM ^②	Outlet Velocity (Fpm)	Final Air Temp. (°F)	Hp	Approx. RPM
Horizontal Delivery	HSB/HC 18L	8,700	1.2	0.4	10	13	230	410	94	1/60	1,000
	HSB/HC 24L	10,400	1.4	0.6	12	14	265	475	95	1/25	1,000
	HSB/HC 33L	14,700	2.0	0.2	13	16	430	455	91	1/25	1,000
	HSB/HC 47L	16,300	2.2	0.2	15	21	540	570	87	1/12	1,000
	HSB/HC 63L	29,000	4.0	0.4	17	21	725	435	96	1/12	1,000
	HSB/HC 86L	33,900	4.6	0.6	18	23	925	550	93	1/8	1,000
HSB/HC 108L	50,500	6.9	1.8	20	23	1,330	510	94	1/8	1,000	

① Horizontal units with horizontal louvers open 30° from vertical plane. Vertical types equipped with cone jet deflector, blades fully opened are shown in bold. Please see page 21 for additional outlet accessory performance data.

② Cfm for horizontal types is entering Cfm. Cfm for vertical and Power-Throw™ types is leaving Cfm.

③ V and PT models have copper tubes, VN and PTN models have 90/10 cupro-nickel tubes.

④ Requires Solid State Motor Speed Controller.

PERFORMANCE DATA



Hot Water Performance Data – High Efficiency Low EWT Models

Table 20.1 - Hot Water Performance Data for BCH and HCH High Efficiency Units at Standard Conditions of 140°F Entering Water and 60°F Entering Air – High Motor Speed

Model No.	Btu/hr	Water Data			Air Data					Motor Data	
		GPM	Pressure Drop (Ft. of Water)	Min/Max GPM	Maximum Mounting Height (ft.) ①	Heat Throw or Spread @ Max. Height ①	Entering CFM	Outlet Velocity (Fpm)	Final Air Temp. (°F)	Hp	Approx. RPM
BCH 103	102,994	10.3	4.7	4.1 / 48	11	39	1,919	524	109	1/2	1,000
BCH 218	217,832	21.8	12.8	8.0 / 88	11	40	3,718	512	113	1	1,000
HCH 22	21,688	2.2	4.90	0.8 / 10	8	27	370	408	113	1/25	1,550
HCH 39	38,547	3.9	1.50	1.4 / 18	8	28	660	409	113	1/25	1,550
HCH 67	66,875	6.7	2.60	2.6 / 31	9	33	1,150	456	113	1/6	1,075
HCH 104	104,204	10.4	4.80	4.1 / 48	11	39	1,830	503	112	1/6	1,075
HCH 170	169,564	17.0	7.40	6.8 / 77	11	42	2,780	475	115	1/2	1,140
HCH 195	194,917	19.5	10.40	8.0 / 88	11	40	3,200	455	115	1/2	1,140

Hot Water Conversion Tables - Example Calculations

Conversion factor example #1:

What is the capacity (Btu/hr), water flow rate (GPM), water temperature drop (°F) and final air temperature (°F) for an HSB 86 at 240°F entering water temperature (EWT) and 70°F entering air temperature (EAT)? What is the maximum mounting height?

Solution:

The factors/data necessary to solve this problem are as follows:

- Hot water heating capacity conversion factor for 240°F EWT and 70°F entering air is 1.201, from Table 15.1.
- The standard rated capacity of an HSB 86 is 60,200 Btu/hr, from Table 18.1.
- The standard rated capacity of an HSB 86 is based on water flow rate of 6.3 GPM, from Table 18.1.
- The standard high motor speed airflow of an HSB 86 is 1340 CFM, from Table 18.1.
- The maximum mounting height, at standard conditions for an HSB 86 is 16 feet, from Table 18.1.
- The mounting height correction factor for 240°F EWT is 0.89 from Table 16.2.

$$Btu_A = Btu_S \times \text{Heating Capacity Factor} = 60,200 \times 1.201 = \underline{72,300 \text{ Btu/hr}}$$

For water flow rate, since only the entering water and air temperature conditions have changed, the water flow rate will remain 6.3 GPM.

$$WTD_A = Btu_A \div (480 \times G_A) = 72,300 \text{ Btu/hr} \div (480 \times 6.3 \text{ GPM}) = \underline{23.9^\circ\text{F}}$$

$$FAT_A = EAT_A + [(460 + EAT_A) \times (Btu_A) \div (576 \times Cfm_S)] = 70^\circ\text{F} + [(460 + 70^\circ\text{F}) \times (72,300) \div (576 \times 1340)] = \underline{120^\circ\text{F}}$$

$$\text{Max. Mounting Height}_A = \text{Max. Mounting Height}_S \times \text{Correction Factor} = 16 \text{ ft.} \times 0.89 = \underline{14.2 \text{ feet}}$$

Conversion factor example #2:

Select a vertical unit heater model that can deliver at least 150,000 Btu/hr with 160°F EWT and 60°F EAT. What will be the required water flow rate, water temperature drop, final air temperature and maximum mounting height?

Solution:

The factors/data necessary to solve this problem are as follows:

- Hot water heating capacity conversion factor for 160°F EWT and 60°F entering air is 0.714, from Table 15.1.
- The mounting height correction factor for 160°F EWT is 1.19, from Table 16.2.

$Btu_S = Btu_A \div \text{Heating Capacity Factor} = 150,000 \div 0.714 = 210,084 \text{ Btu/hr}$ (at standard conditions)
From Table 18.1, a V 279 model will meet the requirement with a rated capacity of 212,600 Btu/hr at standard conditions.

The capacity of the V 279 at actual conditions will be $Btu_A = Btu_S \times \text{Heating Capacity Factor} = 212,600 \times 0.714 = \underline{151,796 \text{ Btu/hr}}$.

Since the capacity was calculated based off standard conditions with factors for changes in entering water and air temperature conditions, the water flow rate will remain 22.2 GPM.

$$WTD_A = Btu_A \div (480 \times GPM_A) = 151,796 \text{ Btu/hr} \div (480 \times 22.2 \text{ GPM}) = \underline{14.2^\circ\text{F}}$$

$$FAT_A = EAT_A + [(460 + EAT_A) \div ((576 \times Cfm_S \div Btu_A) - 1)] = 60^\circ\text{F} + [(460 + 60^\circ\text{F}) \div ((576 \times 5,460 \div 151,796) - 1)] = \underline{86.4^\circ\text{F}}$$

$$\text{Max. Mounting Height}_A = \text{Max. Mounting Height}_S \times \text{Correction Factor} = 40 \text{ ft. (with cone-jet deflector)} \times 1.19 = \underline{47.6 \text{ feet}}$$

Maximum Mounting Heights for Vertical Outlet Accessories, Dimensions

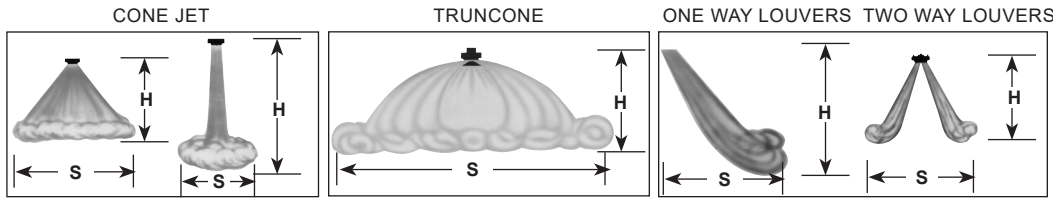

Table 22.1
Mounting Height/Spread for Vertical Unit Air Outlet Accessories ①②③④

Model	Cone-Jet				Truncone				One Way Louvers				Two Way Louvers			
	Standard		L.O.T.		Standard		L.O.T.		Standard		L.O.T.		Standard		L.O.T.	
	H	S	H	S	H	S	H	S	H	S	H	S	H	S	H	S
V/VN 42	15	11	17	13	8	19	9	23	13	11	15	13	8	22	9	26
V/VN 59	19	14	22	16	9	25	11	28	16	14	18	16	10	28	11	32
V/VN 78	20	15	26	19	11	26	14	33	17	15	22	19	11	30	13	38
V/VN 95	20	15	26	19	11	26	14	33	17	15	22	19	11	30	13	38
V/VN 139	24	18	31	23	13	32	17	40	21	18	26	23	13	36	16	46
V/VN 161	27	20	35	26	14	35	18	46	23	20	30	26	14	40	18	52
V/VN 193	30	22	36	27	16	39	19	47	25	22	31	27	15	44	19	54
V/VN 212	30	22	36	27	16	39	19	47	25	22	31	27	15	44	19	54
V/VN 247	34	26	42	32	17	46	21	56	30	26	37	32	18	52	22	64
V/VN 279	37	30	45	36	18	53	22	63	35	30	41	36	21	60	25	72
V/VN 333	37	30	45	36	17	53	20	63	35	30	41	36	21	60	25	72
V/VN 385	36	30	43	36	17	53	20	63	35	30	41	36	21	60	25	72
V/VN 500	44	37	54	45	19	65	24	79	42	37	51	45	26	74	31	90
V/VN 610	43	36	52	44	19	63	24	77	41	41	50	44	25	72	30	88
V 952	-	-	-	-	-	-	-	-	45	56	54	65	26	66	31	82

- ① Data shown for standard 2 lb. steam, 60°F entering air temperature conditions. For louvers or cone-jet, data shown for deflectors in fully-opened position. For mounting height/spread at steam pressures other than 2 lb., multiply the value by the correction factor in Table 10.1.
- ② For mounting height and spread for hot water, multiply the values above by 1.06 to approximate the mounting height and spread at 200°F entering water temperature. For entering water temperature other than 200°F, multiply the values above by 1.06 and then multiply the correction factor in Table 15.2
- ③ All dimensions in feet.
- ④ V models have copper tubes and VN models have 90/10 cupro-nickel tubes.

Figure 22.2 - Vertical Air Outlet Accessories

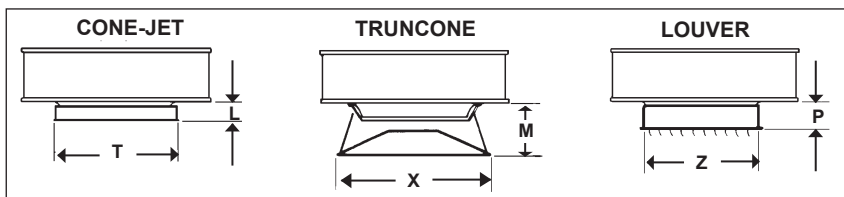

Table 22.2 - Vertical Air Outlet Accessories Dimensions ⑤

Model Number	Cone-Jet		Truncone		Louvers	
	L	T	M	X	P	Z
V 42, V 59	6-1/2	18-7/8	12	22	6-1/2	16-7/8
V 78, V 95	6-1/2	18-7/8	12	22	6-1/2	16-7/8
V 139, V 212	7-1/2	24-3/4	13	27	7-1/2	19-3/4
V 247, V 279	8	26-7/8	16	34	8	22-3/4
V 333	8-1/2	28	16	34	8-1/2	22-3/4
V 385, V 500	10	22-3/4	21	41	10	27-3/4
V 610	10-1/2	36-3/4	21	41	10-1/2	30-3/4
V-952	-	-	-	-	19-1/2	32

⑤ All dimensions in inches.

Motor Data, Step-Down Transformer Accessory Data

Table 23.1 - Motor Data ① ②

Model Number	Motor HP ③	Available Motor Type, Voltage and Power Code							
		Enclosed Air Over						Explosion-proof	
		115/60/1	208/60/1	230/60/1	208/60/3	230/460/3	575/60/3	115/60/1	230/460/60/3
		01	N/A	02	04	05	10	06	09
HSB/HC 18	1/60	✓	④	④	④	④	④	✓	-
HSB/HC/HCH 22, 39, 24, 33	1/25	✓	④	④	④	④	④	✓	-
HSB/HC 47, 63	1/12	✓	④	④	④	✓ ⑤	④	✓	-
HSB/HC/HCH 67, 104, 86, 108	1/6, 1/8	✓	④	④	④	✓ ⑤	④	✓	-
HSB/HC 121	1/5	✓	④	④	✓ ⑤	✓ ⑤	④	✓	✓
HSB/HC/HCH 165, 170, 193, 195	1/3, 1/2 ⑥	✓	④	④	④	✓ ⑤	✓ ⑤	④	✓ ✓
HSB/HC 258-340	1/2	✓	④	④	✓ ⑤	✓ ⑤	④	✓	✓
V/VN 42, 59	1/30	✓	④	④	✓ ⑤	✓ ⑤	④	✓	-
V/VN 78, 95	1/15	✓	④	④	✓ ⑤	✓ ⑤	④	✓	-
V/VN 139	1/5	✓	④	④	✓ ⑤	✓ ⑤	④	✓	✓
V/VN 161-212	1/3, 1/2 ⑥	✓	④	④	✓ ⑤	✓ ⑤	④	✓	✓
V/VN 247	1/2	✓	④	④	✓ ⑤	✓ ⑤	④	✓	✓
V/VN, PT/PTN 279	1/2	✓	④	④	✓ ⑤	✓ ⑤	④	✓	✓
V/VN, PT/PTN 333	3/4	✓	④	④	✓ ⑤	✓ ⑤	④	-	-
V/VN, PT/PTN 385	1	-	-	-	✓	✓	✓	-	✓
V/VN, PT/PTN 500, 610	1-1/2	-	-	-	✓	✓	✓	-	✓
V, PT 952	2	-	-	-	-	✓	-	-	✓

- ① Ratings shown are for Standard and Low Outlet Temperature Models.
- ② All HSB/HC units, V/VN 42 thru V/VN, PT/PTN 333 motor HP listed for power code 01. V/VN PT/PTN 333 thru V/VN, PT/PTN 610 motor HP listed for power code 04 and V/PT 952 motor HP listed for power code 05.
- ③ For model sizes V/VN/PT/PTN 385 and above, motors for Power Codes 04, 05, and 10 do not have thermal overload protection.
- ④ For supply voltages of 208V/60Hz/1ph and all non-explosion-proof 3 phase voltages of 208, 230, 460 and 575, Model Numbers indicated with Note ④, require that a 115V/60Hz/1 phase Power Code 01 unit heater be used with a shipped loose accessory transformer. See Table 23.2 for Transformer Sizes.
- ⑤ For non-explosion-proof 3 phase supply voltages of 208, 230, and 460, Model Numbers indicated with Note ⑤, can be ordered with a Power Code (208V/3ph=04, 230/460V/3ph=05) that provides a motor matched to the supply voltage with amp draw as shown. Alternately, a 115V/60Hz/1 phase Power Code 01 unit heater could be used with a shipped loose accessory transformer. See Table 23.2 for Transformer Sizes.
- ⑥ Explosion-proof 115/60/1 motor is 1/2 HP.

Figure 23.1 Field Installed Transformer Accessory



Table 23.2 - Step-Down Transformer Accessory Selection

Model Number	208/230V/60Hz/1 or 3 phase	230/460V/60Hz/3 phase	575V/60Hz/3 phase
	kVA	kVA	kVA
HSB/HC 18-63	0.50	0.25	0.25
HSB/HC 86-121	0.50	0.50	0.50
HSB/HC 165-193	1.00	0.75	0.75
HSB/HC 258-340	1.00	1.00	1.00
V/VN 42-59	0.50	0.25	0.25
V/VN 78-139	0.50	0.50	0.50
V/VN 161-212	1.00	0.75	0.75
V/VN 247-333	1.00	1.00	1.00
PT/PTN 279-333	1.00	1.00	1.00

kVA Size	Ship Wt. (Lb.)
0.25	7
0.50	13
0.75	15
1.00	19

PERFORMANCE DATA



Cooling Performance Data for High Efficiency HCH and BCH

Table 24.1 - HCH Cooling Performance Data (45°F Entering Water and 80°F Entering Air)

Model No.	Entering DB Air Temp (°F)	Entering WB Air Temp (°F)	CFM	Entering Water Temp (°F)	Flow GPM (Water)	Water Temp Rise (°F)	Total Capacity (MBH)	Sensible Capacity (MBH)	Leaving DB Air Temp (°F)	Leaving WB Air Temp (°F)
HCH 22	80	67	370	45	2.2	10	10.6	8.0	61	58
HCH 39	80	67	660	45	3.5	10	17.6	13.3	62	59
HCH 67	80	67	1150	45	6.7	10	32.3	23.8	61	58
HCH 104	80	67	1,830	45	10.0	10	50.8	37.9	61	58
HCH 170	80	67	2,780	45	17.0	10	85.4	62.0	60	57
HCH 195	80	67	3,200	45	20.0	10	103.0	73.6	59	57

Table 24.2 - BCH Cooling Performance Data (45°F Entering Water and 80°F Entering Air)

Model No.	Entering DB Air Temp (°F)	Entering WB Air Temp (°F)	CFM	Fan Speed	Entering Water Temp (°F)	Flow GPM (Water)	Water Temp Rise (°F)	Total Capacity (MBH)	Sensible Capacity (MBH)	Leaving DB Air Temp (°F)	Leaving WB Air Temp (°F)
BCH 103	80	67	1,919	High	45	10	10	50.1	37.5	62	59
BCH 218	80	67	3,718	High	45	23	10	115.0	82.4	60	57
BCH 103	80	67	370	Medium	45	9	10	46.2	34.5	61	58
BCH 218	80	67	660	Medium	45	21	10	106.5	76.0	59	57
BCH 103	80	67	1,150	Low	45	9	10	44.2	32.5	59	57
BCH 218	80	67	1,830	Low	45	13	10	63.3	63.3	61	60

Dimensions - Horizontal Air Delivery Models

Figure 25.1 - Model Dimensions HSB 18-193

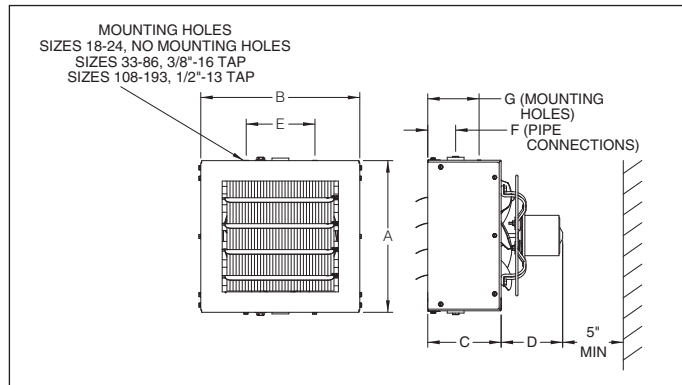

Figure 25.2 - Model Dimensions HSB 258-340

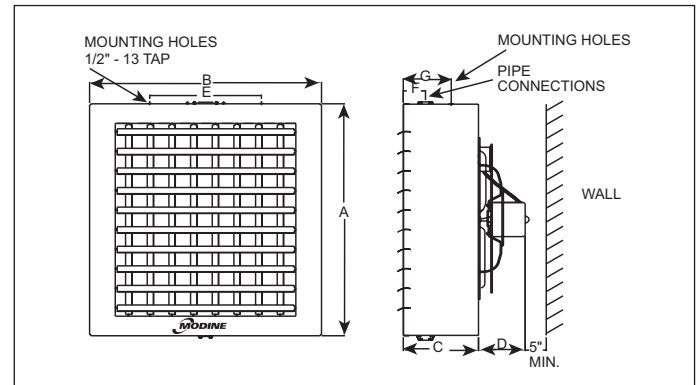

Figure 25.3 - Model Dimensions HC 18-165

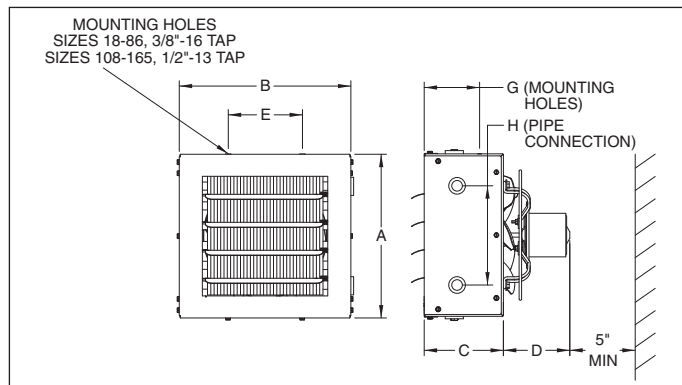

Figure 25.4 - Model Dimensions HC 193-340 ①

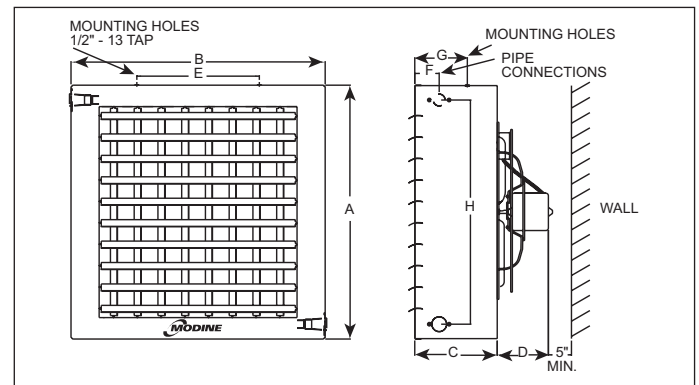

Table 25.1 - Model HSB and HC Dimensions ② ③

① Vertical deflector blades shown are standard on models HC 258-340 and optional on model HC 193.

Model Number	A	B	C	D		E	F	G	H	Female Connections NPT	Fan Diameter	Approx. Shipping Wt. lb.
				115 Std. Motor	115V Exp. Motor							
HSB 18	12-3/8	13	5	5	12-1/4	-	3	-	-	3/4	9	16
HSB 24	12-3/8	13	5	6-1/2	12-1/4	-	3	-	-	3/4	9	20
HSB 33	16-3/8	17-1/2	7-1/4	6-1/2	11-3/4	11	3-5/8	6	-	1-1/4	12	34
HSB 47	16-3/8	17-1/2	7-1/4	8	11-3/4	11	3-5/8	6	-	1-1/4	12	36
HSB 63	20-7/16	21-1/2	7-1/2	8	12	15	3-5/8	6	-	1-1/4	14	48
HSB 86	20-7/16	21-1/2	7-1/2	9	12	15	3-5/8	6	-	1-1/4	14	52
HSB 108	24-7/16	25-1/2	7-1/3	8	13-1/4	18	3-3/4	6-3/8	-	1-1/4	18	74
HSB 121	24-7/16	25-1/2	7-1/3	7-1/2	13-1/4	18	3-3/4	6-3/8	-	1-1/4	18	76
HSB 165	30-1/2	30-1/2	9-1/4	9-1/2	14-7/8	21-1/4	3-3/4	6-3/8	-	1-1/4	22	92
HSB 193	30-1/2	30-1/2	9-1/4	9-1/2	14-7/8	21-1/4	3-3/4	6-3/8	-	1-1/4	22	98
HSB 258	38-1/2	38-1/2	12-1/2	10-1/2	15	18-1/2	3-5/8	7-7/8	-	1-1/4	22	162
HSB 290	38-1/2	38-1/2	12-1/2	10-1/2	15	18-1/2	3-5/8	7-7/8	-	1-1/4	24	168
HSB 340	38-1/2	44-1/2	12-1/2	10-1/2	15	18-1/2	3-5/8	7-7/8	-	1-1/4	24	176
HC 18	11-1/2	13	5	5	12-1/4	5-5/8	2-1/4	4-1/8	7-1/2	1/2	9	16
HC 24	11-1/2	13	5	6-1/2	12-1/4	5-5/8	2-1/4	4-1/8	7-1/2	1/2	9	20
HC 33	15	17-1/2	7-1/4	6-1/2	11-3/4	11	3-5/8	6	10	3/4	12	34
HC 47	15	17-1/2	7-1/4	8	11-3/4	11	3-5/8	6	10	3/4	12	35
HC 63	18-1/2	21-1/2	7-1/2	8	12	15	3-5/8	6	14	3/4	12	48
HC 86	18-1/2	21-1/2	7-1/2	9	12	15	3-5/8	6	14	3/4	14	52
HC 108	22-1/2	25-1/2	7-1/3	8	13-1/4	18	3-5/8	6-3/8	18	3/4	18	74
HC 121	22-1/2	25-1/2	7-1/3	7-1/2	13-1/4	18	3-5/8	6-3/8	18	3/4	18	76
HC 165	26-1/2	29-1/2	9-1/4	9-1/2	14-7/8	21-1/4	3-5/8	6-3/8	22	3/4	22	92
HC 193	30-1/2	32-1/2	9-1/4	9-1/2	14-7/8	21-1/4	3-5/8	4-3/4	26	1-1/4	22	98
HC 258	38-1/2	38-1/2	12-1/2	10-1/2	15	18-1/2	3-5/8	8	34	1-1/4	22	163
HC 290	38-1/2	38-1/2	12-1/2	10-1/2	15	18-1/2	3-5/8	8	34	1-1/4	24	168
HC 340	38-1/2	44-1/2	12-1/2	10-1/2	15	18-1/2	3-5/8	8	34	1-1/4	24	176

② All dimensions in inches.

③ Dimensions shown are for Standard and Low Outlet Temperature Models.

Dimensions - Horizontal Air Delivery Models

Figure 26.1 - Model Dimensions HCH 22-195

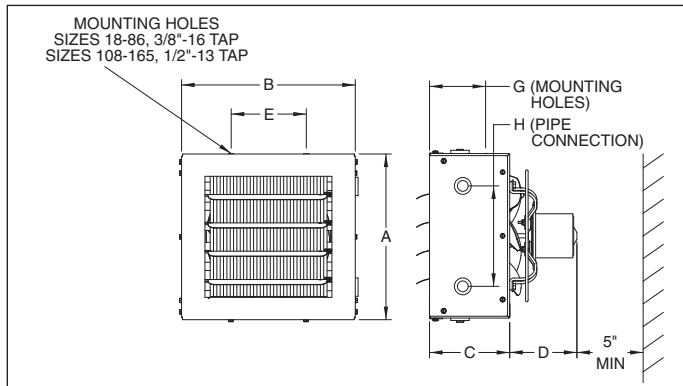

Table 26.2- Model Dimensions HCH 22-195 ①

Model Number	A	B	C	D		E	F		G	H	Connections Copper Tube OD (in.)	Fan Diameter (in.)	Shipping Wt. lb.
				115V Std. Motor	Exp. Motor		Inlet	Outlet					
HCH 22	14.5	20.2	8.4	7	11.5	11.0	3.1	5.7	6.5	7.2	0.5	9	32
HCH 39	18.5	24.5	8.4	7	11.5	15.0	3.1	5.7	6.6	13.2	0.875	12	46
HCH 67	22.5	29.0	9.7	10	16	18.5	3.1	5.7	6.7	17.2	1.125	14	80
HCH 104	26.5	33.0	9.7	8.5	15	21.0	3.2	5.8	6.7	21.2	1.125	18	93
HCH 170	34.5	39.5	11.2	10.5	17	22.0	3.2	5.8	6.7	29.2	1.375	19	145
HCH 195	34.5	45.5	11.2	10.5	17	24.0	3.2	5.8	6.7	29.2	1.375	20	160

① All dimensions in inches.

Figure 26.2 - Model Dimensions BCH 103

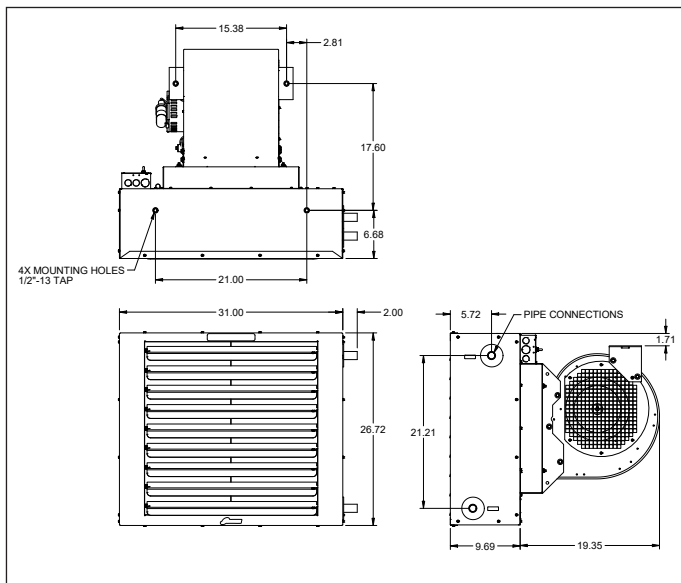
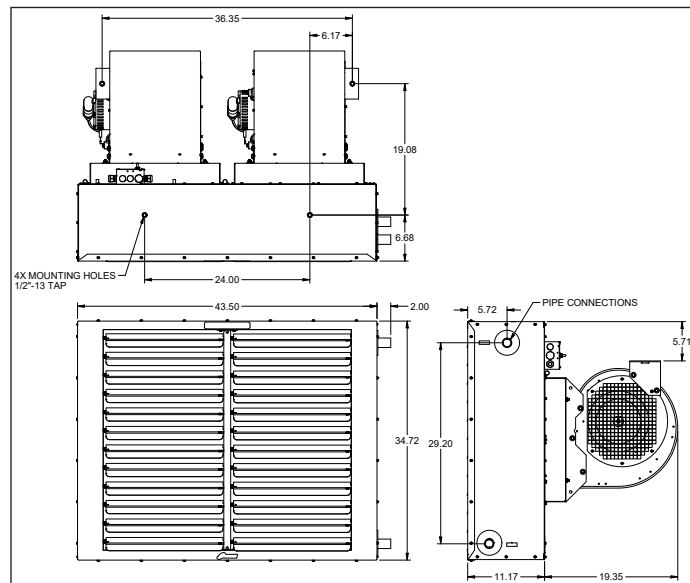

Figure 26.3 - Model Dimensions BCH 218



Dimensions - Vertical Air Delivery Models

Figure 27.1 - Model V/VN and PT/PTN Dimensions

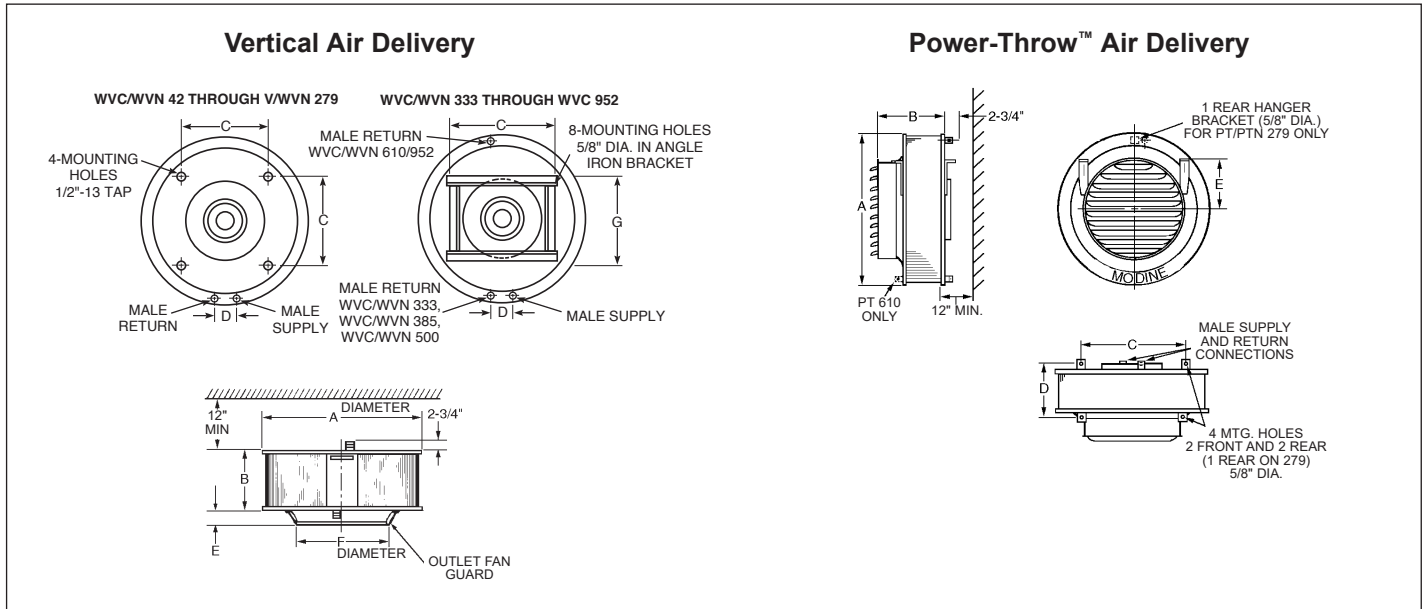

Table 27.1 - Model V/VN and PT/PTN Dimensions ①②③

Model Number	A	B	C	D	E	F	G	Fan Diameter	Male Connections NPT		Approx. Shipping Wt. (lb.)
									Top	Bottom	
V/VN 42	24-3/4	3-5/8	11-3/8	2-1/8	4-3/8	14-1/2	-	14	1-1/4	1-1/4	36
V/VN 59	24-3/4	5-1/8	11-3/8	2-1/8	4-3/8	14-1/2	-	14	1-1/4	1-1/4	42
V/VN 78	24-3/4	6-5/8	11-3/8	2-1/8	2-5/8	16-1/2	-	16	1-1/4	1-1/4	46
V/VN 95	24-3/4	8-1/8	11-3/8	2-1/8	2-5/8	16-1/2	-	16	1-1/4	1-1/4	48
V/VN 139	34-3/4	6-7/8	18-3/8	2-1/8	3	19-1/2	-	19	1-1/2		70
V/VN 161	34-3/4	8-3/8	18-3/8	2-1/8	3	19-1/2	-	19	1-1/2		80
V/VN 193	34-3/4	9-7/8	18-3/8	2-1/8	3	19-1/2	-	19	1-1/2		86
V/VN 212	34-3/4	12-7/8	18-3/8	2-1/2	3	19-1/2	-	19	2	1-1/4	94
V/VN 247	34-3/4	12-7/8	18-3/8	2-1/2	3	21-1/2	-	21	2	1-1/4	108
V/VN 279	34-3/4	14-3/8	18-3/8	2-1/2	3	21-1/2	-	21	2	1-1/4	112
V/VN 333	43-1/4	14-5/8	31-1/2	2-7/8	3-1/8	22-1/2	18-1/5	22	2-1/2	1-1/2	166
V/VN 385	43-1/4	14-1/2	31-1/2	2-7/8	3-1/2	27-1/2	18-1/5	27	2-1/2	1-1/2	168
V/VN 500	43-1/4	19	31-1/2	2-7/8	3-1/2	27-1/2	18-1/5	27	2-1/2	1-1/2	360
V/VN 610	51-1/2	19-1/8	31-3/8	-	3-3/4	30-1/2	31-3/8	30	2-1/2	1-1/2	450
V 952	53-3/4	21-1/8	30	-	3-1/2	31	30	30	3	3	487
PT/PTN 279	34-3/4	22-5/8	25-1/4	16-3/4	16-3/4	-	-	21	2	1-1/4	122
PT/PTN 333	43-1/4	23-7/8	30	15-3/4	14-3/8	-	-	22	2-1/2	1-1/2	176
PT/PTN 385	43-1/4	25-3/4	30	15-3/4	14-3/8	-	-	27	2-1/2	1-1/2	184
PT/PTN 500	43-1/4	29	30	20-1/4	14-3/8	-	-	27	2-1/2	1-1/2	376
PT/PTN 610	51-1/2	29-5/8	30	20-3/8	21	-	-	30	2-1/2	1-1/2	472
PT 952	53-3/4	26-3/8	30	23-1/8	26-7/8	-	-	30	3	3	487

① All dimensions in inches.
 ② Dimensions shown are for Standard and Low Outlet Temperature Models.
 ③ See page 23 for optional air outlet accessory dimensions.

Model Identification

Figure 29.1
Model Number Designation

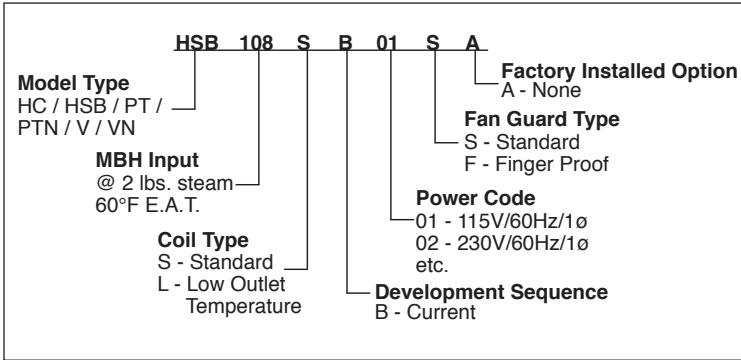

Figure 29.2
Serial Number Designation

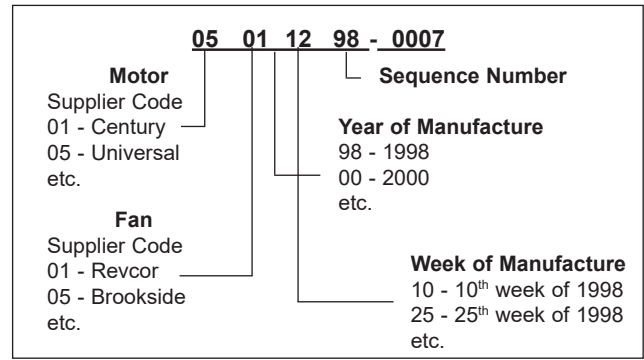

Figure 29.3
Model Identification Plate

HYDRONIC UNIT HEATER		Made in U.S.A.	STEAM/HOT WATER COIL	 3087217 Intertek Conforms to UL Std. 1995 / Cert. to CAN/CSA Std. C222 No.236-05 CRN OH9234.5C	INSTALL UNIT AT LEAST 8 FT. ABOVE THE FLOOR AND OUT OF REACH. INSTALLER 45M MINIMUM AU DESSUS DU SOL ET HORS D'ATTEINTE.	5H087890000 Rev. A	
MODEL NUMBER NUMERO DE MODELE	PT 500SB04SA	SERIAL NUMBER NUMERO DE SERIE	15013519-5127				
MOTOR HP 1-1/2 V/HZ/PH	200/60/3	FLA	5.6	MCA	7	MOP	15
CLEARANCE TO COMBUSTIBLE MATERIAL / DÉGAGEMENT DE MATIÈRES COMBUSTIBLES		0 IN / CM					
Modine Manufacturing Company 1500 DeKoven Avenue, Racine, WI 53403-2552		Phone: 800-828-4328 www.modinehvac.com					

Specification for Horizontal, Vertical and Power-Throw™ Models

General

Contractor shall furnish and install steam/hot water unit heater model _____. Performance shall be as indicated on the equipment schedule in the plans. Units shall be listed by CSA as certified to CAN/CSA-C22.2 No. 236-05 "Heating and Cooling Equipment" and UL Std. No. 1995 "Heating and Cooling Equipment." Additionally for Canada, the units shall have CRN registered heat exchangers.

Casing

HSB and HC Models - Casings on model sizes 18 through 86 are 20 gauge steel (18 gauge on all other models) and consist of front and back halves. Both halves are joined together at the top and bottom utilizing the condenser mounting screws. Casing top is provided with threaded hanger connections for unit suspension (except for HSB 18 and HSB 24 which are directly mounted to the supply and return piping). Fan venturi is formed in casing back half.

Vertical and Power-Throw™ Models - Casings consist of two circular 18 gauge steel covers. With the coil in between, the covers are securely bolted together to form a single unit. The bottom cover has a die-formed fan venturi. The top cover incorporates a motor cooling cone, which shields the motor from coil heat therefore prolonging motor life. An opening is also provided for circulation of motor cooling air.

All Models - Casing shall be treated to prevent corrosion and painted with a corrosion resistant, baked, polyester powdercoat gray-green finish.

Condenser

Condenser coils are of the extended surface type, utilizing aluminum fins and DLP-type copper tubes with malleable iron supply and return connections for HSB units, cast bronze connections for HC models and Schedule 40 steel pipe for V/PT models. Tubes are mechanically bonded to the collars of the fins. The condensers are warranted for operation at steam or hot water pressures and temperatures up to 150 psig and 375°F for copper coils and 250 psig and 400°F for 90/10 cupro-nickel coils.

Fins are continuous across the width and depth of the condenser and are vertically oriented to minimize the collection of dirt and dust.

Canadian Standards Association (CSA) requirements state that explosion-proof units (Power Codes 06 and 09) may not be used with fluid temperatures in excess of 329°F or pressures in excess of 87 psig and still maintain their explosion-proof rating for National Electric Code ignition temperature rating T3B for grain dust.

All coils are leak tested at 165 to 200 psig, air under water.

Horizontal Models - Coils are of serpentine design with horizontal tubes, vertical fins and center supply and return connections at top and bottom of unit (except HC models, which have side connections). All tube bends are brazed. All tubes have individual expansion bends. Copper tubes are 1" O.D. with 0.030" wall thickness (except HSB/HC 18 and 24 which are 5/8" O.D. with 0.028" wall thickness).

Vertical and Power-Throw™ Models - Coils are circular, providing for natural expansion. Each tube is continuous between supply and return header. All tube joints are silver soldered. Copper tubes are 5/8" O.D. with 0.028" wall thickness.

Motors - See page 8 for Power Code and motor descriptions and page 23 for motor amp draw information. Motors are designed for continuous duty and can operate in a maximum ambient temperature of 104°F(40°C).

Fans/Fan Guards - Fans are aluminum on all units and are secured to a steel hub. Each fan is balanced and is designed specifically for the unit heater on which it is installed. Horizontal units are equipped with a combination fan guard/motor-mounting bracket. The guard is constructed of steel rod. Vertical units are supplied with an outlet fan guard covering the opening in the bottom of the unit.

Air Deflectors - Horizontal units, including the Power-Throw™ units, are furnished with horizontal air deflectors as standard. The deflectors are adjustable to almost any desired position for downward, straight or upward airflow. Vertical deflectors are available as an accessory for HSB/HC models through size 193, standard on model sizes 258-340. See page 22 for air outlet accessories for vertical models.

PAGE INTENTIONALLY LEFT BLANK

PAGE INTENTIONALLY LEFT BLANK

Products from Modine are designed to provide indoor air-comfort and ventilation solutions for residential, commercial, institutional and industrial applications. Whatever your heating, ventilating and air conditioning requirements, Modine has the product to satisfy your needs, including:

HVAC

- Unit Heaters:
 - Gas
 - Hydronic
 - Electric
 - Oil
- Ceiling Cassettes
- Duct Furnaces
- Hydronic Cabinet Unit Heaters and Convectors
- Infrared Heaters
- Make-up Air Systems
- Unit Ventilators

School Products

- Vertical Packaged Classroom HVAC:
 - DX Cooling/Heat Pump
 - Water/Ground Source Heat Pump
 - Horizontal/Vertical Unit Ventilators

Specific catalogs are available for each product. Catalogs 75-136 and 75-137 provide details on all Modine HVAC equipment.



Modine Manufacturing Company

1500 DeKoven Avenue
Racine, Wisconsin 53403-2552
Phone: 1.800.828.4328 (HEAT)
www.modinevac.com

© Modine Manufacturing Company 2026