

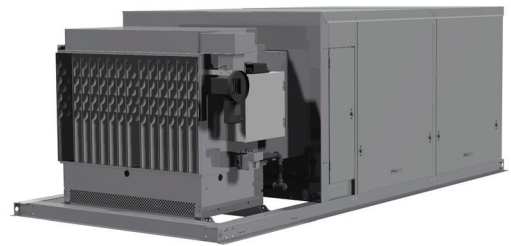

GAS-FIRED INDOOR AND OUTDOOR DUCT FURNACES

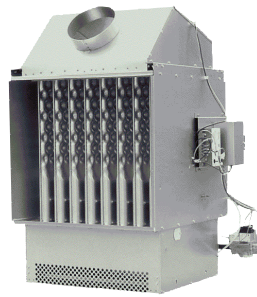

**INDOOR GRAVITY AND POWER VENTED
DFG/DFP, DBG/DBP, DCG/DCP**

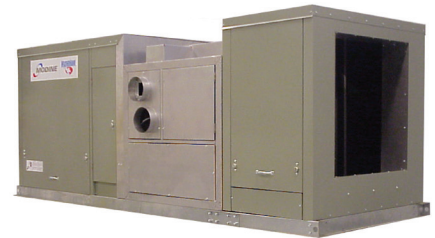

**INDOOR SEPARATED COMBUSTION
DFS, DBS, DCS**



**OUTDOOR GRAVITY AND POWER EXHAUSTED
"H" SERIES**



A complete line of both indoor and outdoor heating and ventilating equipment is offered. This catalog describes in detail the gas-fired, gravity vented, power vented, and separated combustion duct furnace/make-up air units.

Depending on the requirements of the application, the duct furnace can be ordered either by itself, a furnace with a blower section, a furnace with a blower and cooling coil sections, a

furnace with a blower and downturn sections, or a furnace with a blower, cooling coil, and downturn sections. With these configurations, the units can satisfy a building's heating, make-up air, cooling, or ventilating requirements.

This catalog describes the design benefits, construction features, performance data, unit selection procedure, control applications, and the optional and accessory devices available.

Refer to the Page 75 (inside back cover)
for Model Nomenclature

Table of Contents	Page
Features and Benefits	3
Duct Furnace Design Features	4-5
Duct Furnace Performance Data	6
Duct Furnace Pressure Drop Curves	7
Duct Furnace Unit Selection	8
Duct Furnace Unit Dimensions	9-13
System Unit Design Features	14-15
System Unit General Performance Data	16-17
Model Nomenclature Description	18-22
Options	24-26
Thermostats	27
Accessories	28
Control Applications	29-33
System Unit Selection	34-35
Option & Accessory Pressure Drop Data	36
Blower Performance Data	37-39
Sheave Arrangements	40
Electrical Data	41
Motor Data	42-44
System Unit Dimensions - Indoor Gravity Vented / Power Vented / Separated Combustion	46-51
System Unit Dimensions - Outdoor Gravity Vented / Power Vented	52-55
Dimensions - Indoor Unit Base	56
Dimensions - Outdoor Unit Base	57
Dimensions - Roof Curbs (Outdoor)	58
Dimensions - Rainhood and Birdscreen (Outdoor)	59
Dimensions - Remote Panel	59
System Unit Weights	60
Cooling Cabinet Specifications	62-63
DX Cooling Coil Performance Data	64-65
Chilled Water Cooling Coil Performance Data	66-67
Cooling Coil Dimensions	68
Evaporative Cooler Specifications and Dimensions (Outdoor)	69-70
Specifications	71-74
Model Nomenclature	75

WARNING

Do not locate ANY gas-fired unit in areas where chlorinated, halogenated or acid vapors are present in the atmosphere.

WARNING

Appliances must not be installed where they may be exposed to a potentially explosive or flammable atmosphere.

As Modine Manufacturing Company has a continuous product improvement program, it reserves the right to change design and specifications without notice.

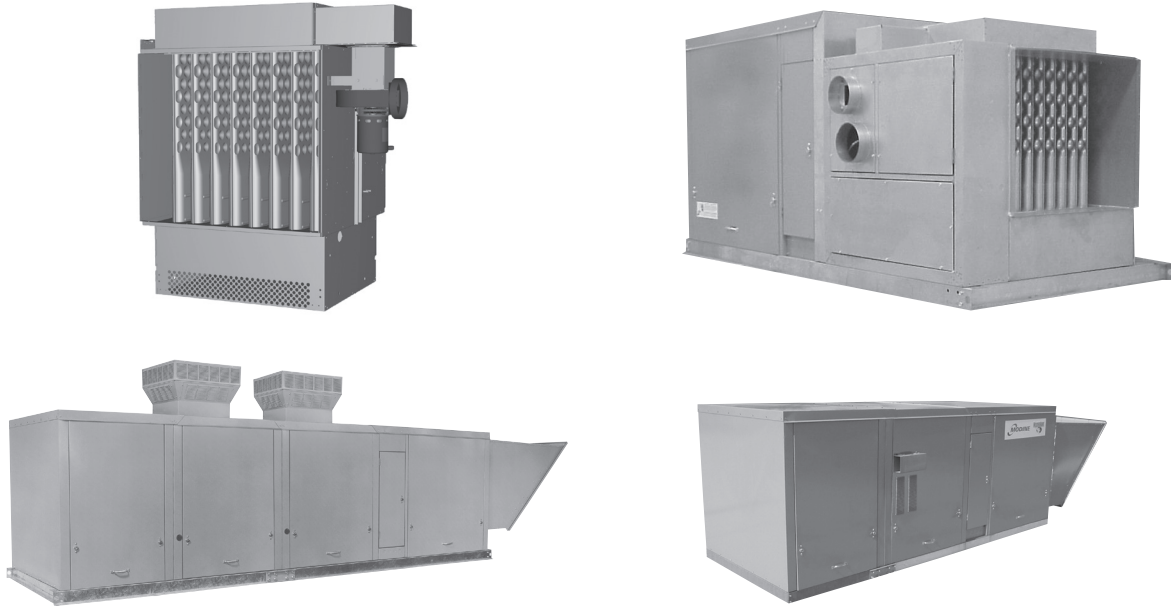

Table 3.1 - Product Features and Benefits

	Feature	Benefit
Full Product Line Offering	All models are 80% thermally efficient	Saves fuel compared with less efficient equipment
	Blower performance up to 3.0" W.C.	Applications can include longer ductwork lengths or accessories with higher pressure drops
	DX or chilled water section with factory installed coil	One unit can provide both heating and cooling
	Building management system compatible controls	Allows for energy savings by operating the unit only during the required time periods
	Safety control devices (Smoke detectors and gas safety switches)	Insures the safety of the building occupants
	Input ranges from 75,000 to 1,200,000 Btu/Hr	Flexible units to accommodate a variety of heating requirements
Easy To Install and Service	Separate line and low voltage terminal strips (premium units) or low voltage terminal connections (standard units)	Allows for quick and accurate field wiring connections
	Dead-Front disconnect switches	Saves labor time compared to field mounting a box type disconnect switch
	Job specific wiring diagrams	Allows for easy troubleshooting
	Gas manifold positioned to allow for easy burner/pilot access and servicing	Prevents the need to disconnect the gas piping when servicing the burner
	Design provides simplified heat exchanger removal	The heat exchanger can be removed without disconnecting gas, electrical, or ductwork connections (separated combustion and outdoor units)
	Gas manifold designed for easy orifice inspection	Simplifies the service inspection process

Indoor Gravity Vented (DFG)

The indoor gravity vented duct furnace was designed to be an economical choice for use with a building's heating, heating/cooling and make-up air systems. Available in 11 gravity vented model sizes, the unit covers a wide variety of applications. They have input ranges from 75,000 to 400,000 Btu/Hr and can operate on either natural or propane gas. The airflow direction can be specified when ordering the unit. The duct furnace is certified for location either upstream or downstream from cooling coils and has a drain pan that allows connection to a condensate drain line. Because the unit relies on a natural draft to vent properly, power vented units should be considered if the vent system is horizontal or if the space in which the unit is located is generally under a negative pressure.

Indoor Power Vented (DFP)

Model DFP includes all the items featured for Model DFG, but adds an integral power exhauster that allows for:

- Vertical or horizontal venting with the smallest diameter vent pipe possible.
- The ability to overcome reasonable negative pressures seen in buildings with inadequate make up air.
- Improved building efficiency through the reduction of off-cycle vent losses.

Figure 4.1 - Indoor Duct Furnaces

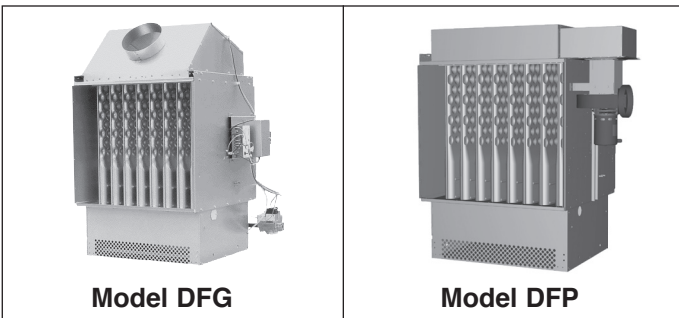

Indoor Separated Combustion (DFS)

Model DFS builds upon the advantages of the Power Vented Model DFP, but is specifically designed for buildings with hostile environments, such as dirty or high humidity applications. This model features:

- Separate electrical and gas control access with fully gasketed doors to seal components from the environment.
- Combustion air that is drawn from outside to ensure the unit has plenty of fresh, clean air.
- Since combustion air is introduced from outside, off-cycle vent losses are essentially eliminated, further improving building efficiency.
- Horizontal or vertical two-pipe or concentric venting options.

Figure 4.2 - Indoor Duct Furnaces

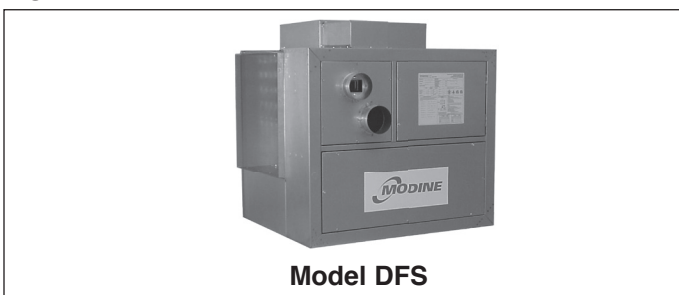

Outdoor Gravity & Power Exhausted (HFG/HFP)

The outdoor duct furnace was designed for use with a building's heating, heating/cooling and make-up air systems. Available in 11 gravity vented or power exhausted model sizes, the unit covers a wide variety of applications. They have input ranges from 75,000 to 400,000 Btu/Hr and can operate on either natural or propane gas. The airflow direction can be specified when ordering the unit. The duct furnace is certified for location either upstream or downstream from cooling coils and has holes to drain any condensate that may form on the roof.

Figure 4.3 - Outdoor Duct Furnaces

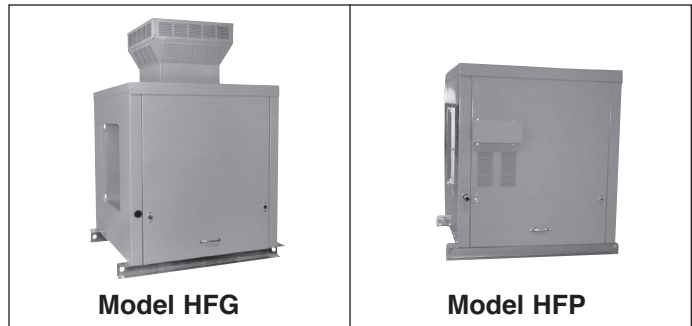

Standard Features:

- CSA and/or ETL certification for US and Canada.
- 80% minimum thermal efficiency.
- 20 gauge aluminized steel cabinet (DFG, DFP, DFS).
- 18 gauge aluminized steel cabinet with a baked-on polyester powder paint finish on exterior casing parts (HFG, HFP).
- Rail type mounting base for slab installation (HFG, HFP).
- 115V step down transformer with 24V gas controls.
- Aluminized steel heat exchanger & burner with stainless steel separator strip.
- Intermittent pilot ignition, continuous retry control system with single-stage gas valve for operation on natural gas.
- Right side access to burner and gas controls (when looking into the discharge) with slide-out burner drawer.
- Side or bottom gas connection access.
- Separate electrical, venting, and gas control access with fully gasketed doors (DFS).
- High limit safety control.
- Certified to 3.0" W.C. external static pressure.
- Control terminal board (DFG, DFP).
- Separate line and low voltage terminal strips (DFS, HFG, HFP).
- Blocked vent safety switch (DFG).
- Combination combustion air/exhaust vent cap (HFG).
- Power exhauster motor (DFP, DFS, HFP).
- Differential pressure vent switch (DFP, DFS).
- Power exhauster pre-purge and post-purge (DFP, DFS).

Optional Features - Factory Installed

- 409 stainless steel heat exchanger and burner.
- 409 stainless steel drip pan.
- Note:** A 409 stainless steel heat exchanger and burner is recommended when installed downstream of a cooling coil or evaporative cooler, or when the combined entering/return air to the unit is below 40°F.
- Control system for operation on propane gas.
- Two-stage or electronic modulation controls.
- Building management compatible gas controls for electronic modulation using a 0-10VDC or 4-20mA signal.
- Multiple furnace electronic amplifier for controlling up to 4 duct furnaces with one discharge air sensor.
- Control step down transformers for 208/230V/1Ph and 208/230/460/575V/3Ph.
- Left side access to burner and gas controls.
- Adjustable differential air flow proving system.
- Fan delay timer.
- High and/or low gas pressure switches.
- Manual reset high limit switch.
- Timed freeze protection.
- Supply air fire stat.
- Control relay - double pole, double throw.
- Installed duct thermostat – two-stage.
- Installed duct thermostat – electronic modulation (DFS, HFG, HFP).
- Premium control box and gas control string with separate line and low voltage terminal strips (DFG, DFP).

Accessories - Field Installed

- Power exhauster with vent adapter (DFG).
- Concentric vent kits—horizontal and vertical (DFS only - see Figure 5.1).
- Power exhauster step down transformers for 460V and 575V (DFP, DFS, HFP).
- Electronic programmable room thermostats for single and two stage units.
- Smoke detector.
- 7-day digital and mechanical time clocks.
- Single-stage room thermostats.
- Two stage room and duct thermostats.
- Room thermostat guards.
- Electronic two stage duct thermostats.
- Electronic modulating room and duct thermostats and a room override for the duct thermostat.
- Summer/winter switch.
- Condensate connection drain kits.
- Pipe hanger adapter kits.
- 5-10 PSI gas pressure regulator.
- 4 foot exhaust vent extension (HFG, HFP).

Figure 5.1 - Concentric Vent Kits (Model DFS)

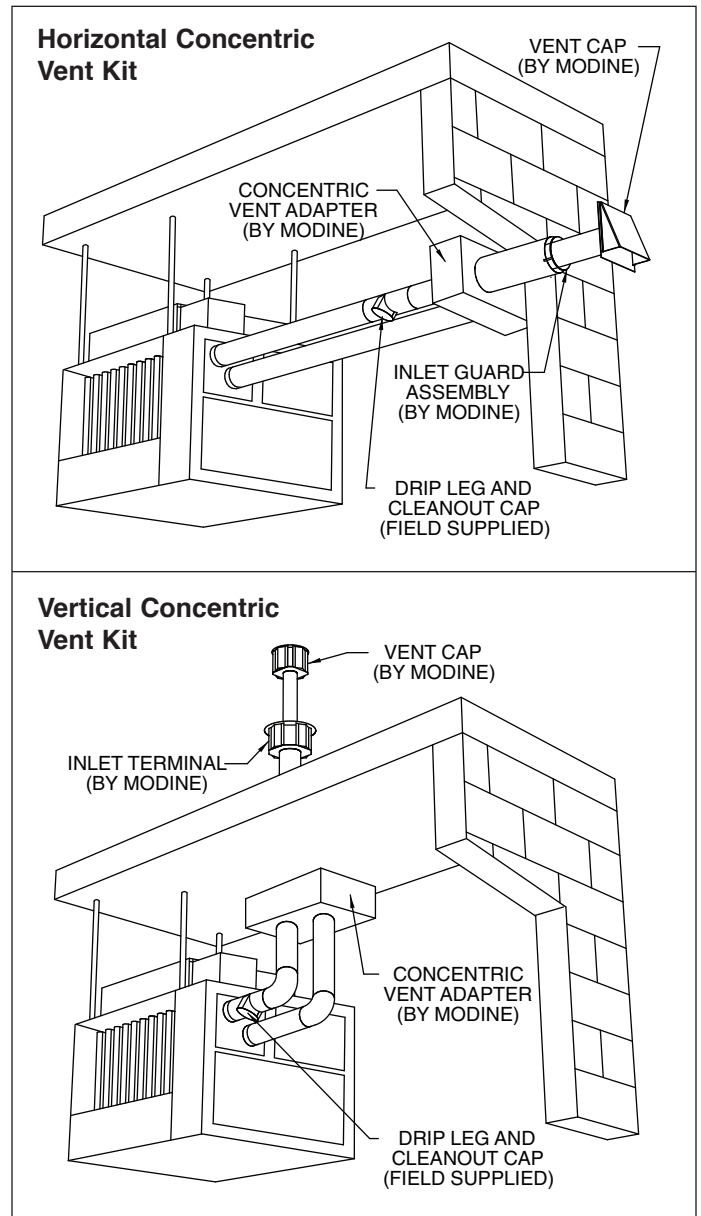

Variable Air Movement Applications

When the air mover supplied by others can provide variable air movement (i.e. 2-speed or variable frequency drive units), the certified allowable minimum CFM of the outdoor duct furnace can be 66% of the minimum listed CFM in Table 6.2 if the unit is applied as follows:

1. The unit is provided with two-stage or electronic modulation gas controls.
2. The unit is provided with a factory installed discharge air controller.
3. The system does not include a room thermostat.

The factory installed discharge air thermostat will prevent the unit from firing above the allowable 100°F rise when the unit is at or above the minimum CFM by monitoring the discharge air and going to low fire. A room thermostat cannot be used, because it is located remote from the unit and could cause the unit to over-fire.

DUCT FURNACE PERFORMANCE DATA



Table 6.1 - Air Temperature Rise - Low Temperature Rise Separated Combustion/Outdoor Duct Furnaces ① ② ③

Model Size	Btu/Hr		Air Temperature Rise Through Unit (°F)								
			20	25	30	35	40	45	50	55	60
	Input	Output	Max	CFM							Min
75	75,000	60,000	2778	2222	1852	1587	1389	1235	1111	1010	926
100	100,000	80,000	3704	2963	2469	2116	1852	1646	1481	1347	1235
125	125,000	100,000	4630	3704	3086	2646	2315	2058	1852	1684	1543
150	150,000	120,000	5556	4444	3704	3175	2778	2469	2222	2020	1852
175	175,000	140,000	6481	5185	4321	3704	3241	2881	2593	2357	2160
200	200,000	160,000	7407	5926	4938	4233	3704	3292	2963	2694	2469
225	225,000	180,000	8333	6667	5556	4762	4167	3704	3333	3030	2778
250	250,000	200,000	9259	7407	6173	5291	4630	4115	3704	3367	3086
300	300,000	240,000	11111	8889	7407	6349	5556	4938	4444	4040	3704
350	350,000	280,000	12963	10370	8642	7407	6481	5761	5185	4714	4321
400	400,000	320,000	14815	11852	9877	8466	7407	6584	5926	5387	4938

Table 6.2 - Air Temperature Rise - High Temperature Rise Separated Combustion/Outdoor Duct Furnaces and All Gravity Vented Indoor Duct Furnaces ① ② ③

Model Size	Btu/Hr		Air Temperature Rise Through Unit (°F)											
			20 ④	40 ④	50 ④	60	65	70	75	80	85	90	95	100 ⑤
	Input	Output	Max	CFM										Min
75	75,000	60,000	2778	1389	1111	926	855	794	741	694	654	617	585	556
100	100,000	80,000	3704	1852	1481	1235	1140	1058	988	926	871	823	780	741
125	125,000	100,000	4630	2315	1852	1543	1425	1323	1235	1157	1089	1029	975	926
150	150,000	120,000	5556	2778	2222	1852	1709	1587	1481	1389	1307	1235	1170	1111
175	175,000	140,000	6481	3241	2593	2160	1994	1852	1728	1620	1525	1440	1365	1296
200	200,000	160,000	7407	3704	2963	2469	2279	2116	1975	1852	1743	1646	1559	1481
225	225,000	180,000	8333	4167	3333	2778	2564	2381	2222	2083	1961	1852	1754	1667
250	250,000	200,000	9259	4630	3704	3086	2849	2646	2469	2315	2179	2058	1949	1852
300	300,000	240,000	11111⑥	5556	4444	3704	3419	3175	2963	2778	2614	2469	2339	2222
350	350,000	280,000	11111⑦	6481	5185	4321	3989	3704	3457	3241	3050	2881	2729	2593
400	400,000	320,000	11111⑦	7407	5926	4938	4558	4233	3951	3704	3486	3292	3119	2963

- ① Ratings are shown for elevations up to 2000 feet. For higher elevations, the input rating should be reduced at the rate of 4% per 1000 feet elevation above sea level. For Canada, in elevations between 2000 and 4500 feet, the unit must be derated to 90% of the rating listed above.
- ② All units except DFG are approved for use in California by CEC.
- ③ High air temperature rise separated combustion/outdoor units include an air distribution baffle and restrictor change when compared to the low air temperature rise separated combustion/outdoor units. Field conversion of a high air temperature rise to a low air temperature rise unit (or the opposite) requires a factory supplied conversion kit.
- ④ For separated combustion/outdoor units, the certified range of the High Temperature Rise Duct Furnaces is 20°-100°F but it is recommended that they be used from 60°-100°F to reduce the system pressure drop. All gravity vented indoor duct furnaces are supplied with a factory installed air baffle. For applications where an air temperature rise less than 60°F is desired, it is recommended to remove this baffle to reduce system pressure drop.
- ⑤ For Variable Air Movement Applications, see page 5.
- ⑥ For High Temp Rise Separated Combustion and Outdoor Furnaces the max CFM is 9578 due to the maximum 3" W.C. static pressure on the heat exchanger. See Figure 7.2.
- ⑦ The maximum CFM for the 350 and 400 results in a 23°F and a 27°F air temperature rise (respectively) based on the maximum unit pressure drop.

Air Temperature and External Static Pressure Limits

The maximum allowable discharge air temperature is 150°F. The maximum allowable air temperature rise for Low Air Temperature Rise Separated Combustion/Outdoor Units is 60°F. The maximum allowable air temperature rise for High Air Temperature Rise Separated Combustion/Outdoor and all Gravity Vented Units is 100°F. All duct furnaces are designed for a maximum allowable static pressure of 3.0" W.C. on the heat exchanger.

Figure 6.1 - Recommended Unit Configurations

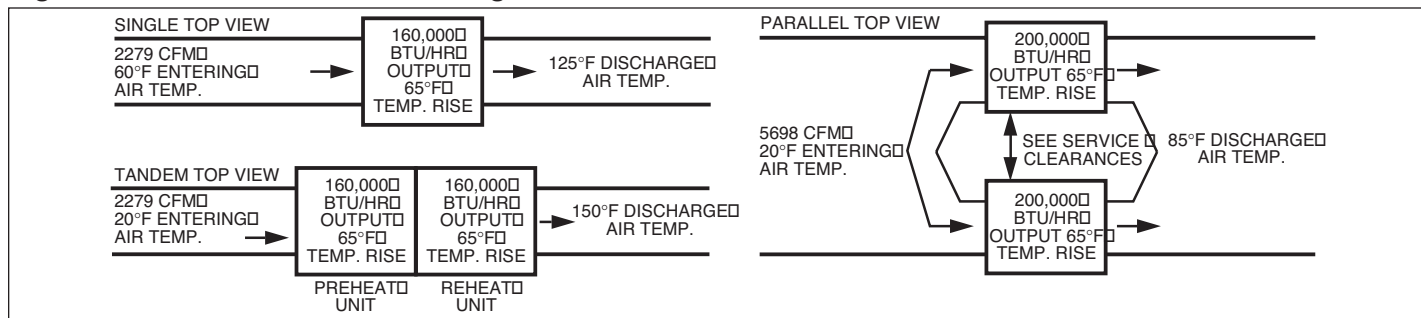

Figure 7.1
Low Air Temperature Rise Separated Combustion/Outdoor Duct Furnace and Gravity Vented Indoor Duct Furnace Without Baffle Pressure Drop vs CFM curves

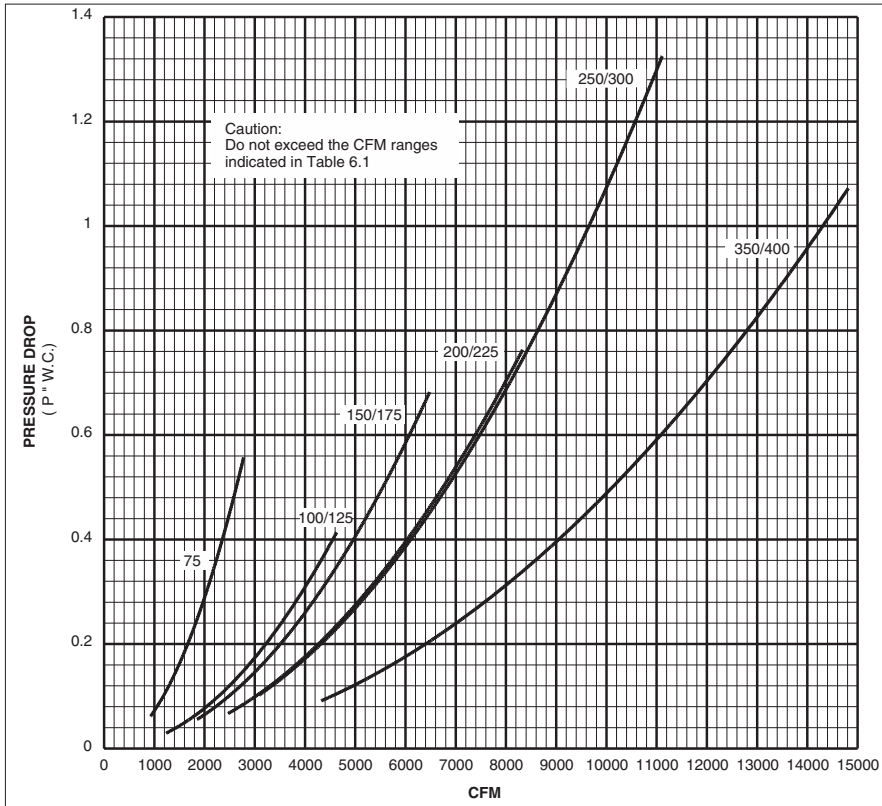
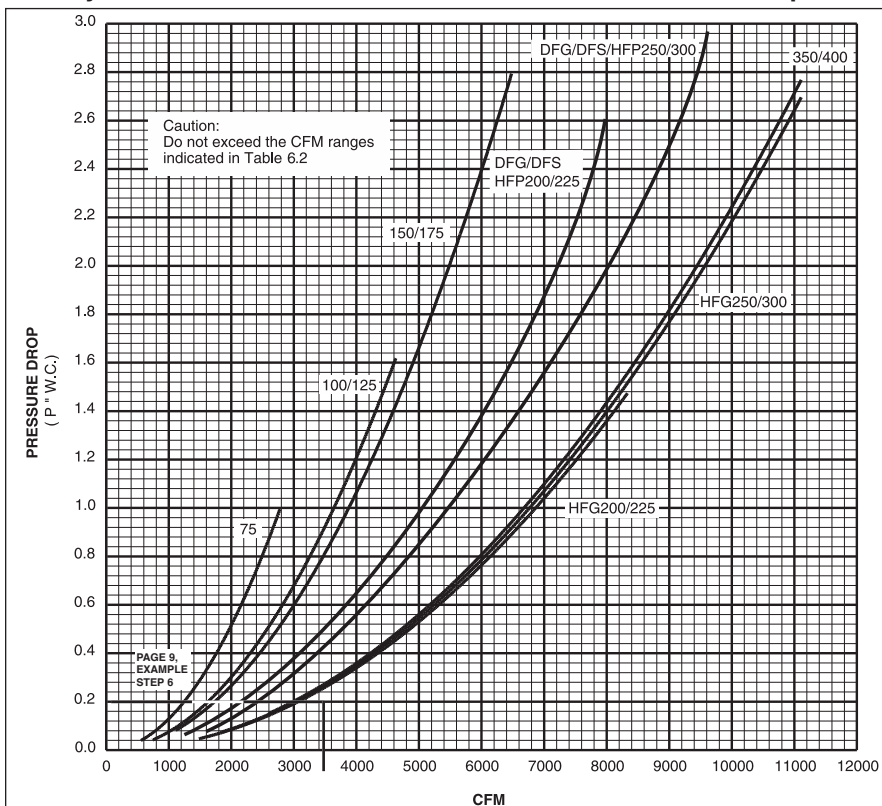

Figure 7.2
High Air Temperature Rise Separated Combustion/Outdoor Duct Furnace and Gravity Vented Indoor Duct Furnace With Baffle Pressure Drop vs CFM curves



Selecting Model and Determining Duct Furnace Pressure Drop

CAUTION

Do not provide less than the minimum CFM throughput shown in Tables 6.1 and 6.2 unless the unit meets Variable Air Movement Applications conditions.

Selecting Model

To select the proper outdoor duct furnace, two of the following three pieces of information must be given.

Either:

1. The required Btu/Hr output.
2. The required CFM.
3. The required ΔT ($^{\circ}F$).

The formula in step 3B will calculate the third item.

Then use the following procedure:

1. Determine the required Btu/Hr output.
2. Determine the Btu/Hr input required based on the outputs shown in Tables 6.1 and 6.2.
3. Determine the required air temperature rise through the duct furnace. The temperature rise is determined by either of the following methods:
 - A. Using Table 6.1 and 6.2 - Air Temperature Rise find the model number of the unit with the required output Btu/Hr. Follow the row until the air volume (CFM) is found. Then proceed up the column to locate the corresponding temperature rise.
 - B. Using the algebraic formula:

$$\Delta T (^{\circ}F) = \frac{\text{Btu/Hr output}}{\text{CFM} \times 1.08}$$
4. Determine the unit air temperature rise style. Based on the required air temperature rise, determine if a high temperature rise or a low temperature rise unit is needed. Low temperature rise units can only be used if the required temperature rise is between 20 $^{\circ}$ -60 $^{\circ}$ F. High temperature rise units are used when the temperature rise is between 60 $^{\circ}$ -100 $^{\circ}$ F.

For Variable Air Movement Applications:

The selection of the unit should be based on the low speed temperature rise of the unit. Thus, if the high speed air temperature rise is 40 $^{\circ}$ F and the low speed air temperature rise is 80 $^{\circ}$ F, a high air temperature rise unit should be selected.

Determining Duct Furnace Pressure Drop

To determine the duct furnace pressure drop, use the following procedure:

5. Based on the style (high or low air temperature rise) of unit, determine which pressure drop curve should be used. Figure 7.1 for Low Air Temperature Rise units and Figure 7.2 for High Air Temperature Rise units.
6. Enter either figure at the required CFM and follow up the curves until the CFM intersects with the curve for the duct furnace Btu/Hr input that was selected. Move horizontally across to the left and read the pressure drop.

Selection Example

Model and Duct Furnace Pressure Drop Selection

Given:

1. Btu/Hr output = 240,000 Btu/Hr
2. Temperature Rise = 65 $^{\circ}$ F

Selection:

1. The required Btu/Hr output = 240,000 Btu/hr.
2. From either Table 6.1 and 6.2, the HFG300 has an
Input = 300, 000 Btu/hr
Output = 240,000 Btu/Hr
3. The required temperature rise is 65 $^{\circ}$ F. Using Table 6.2 for a 65 $^{\circ}$ F air temperature rise, the CFM can be found to be 3419. Also, the CFM can be calculated by using the equation:

$$\text{CFM} = \frac{\text{Btu/Hr output}}{\Delta T (^{\circ}F) \times 1.08} \quad \text{or} \quad \frac{240,000}{65 \times 1.08} = 3419$$

4. Since the 65 $^{\circ}$ F air temperature rise is between 60 $^{\circ}$ -100 $^{\circ}$ F, the unit would be a high air temperature rise unit.
5. To determine the pressure drop, use Figure 7.2 for high temperature rise units.
6. Enter the bottom of the table at 3419 CFM until it intersects the HFG300 curve. Then move horizontally across to the left and read the pressure drop of 0.26" W.C.

Figure 9.1
Indoor Gravity Vented Duct Furnace Dimensions (DFG)

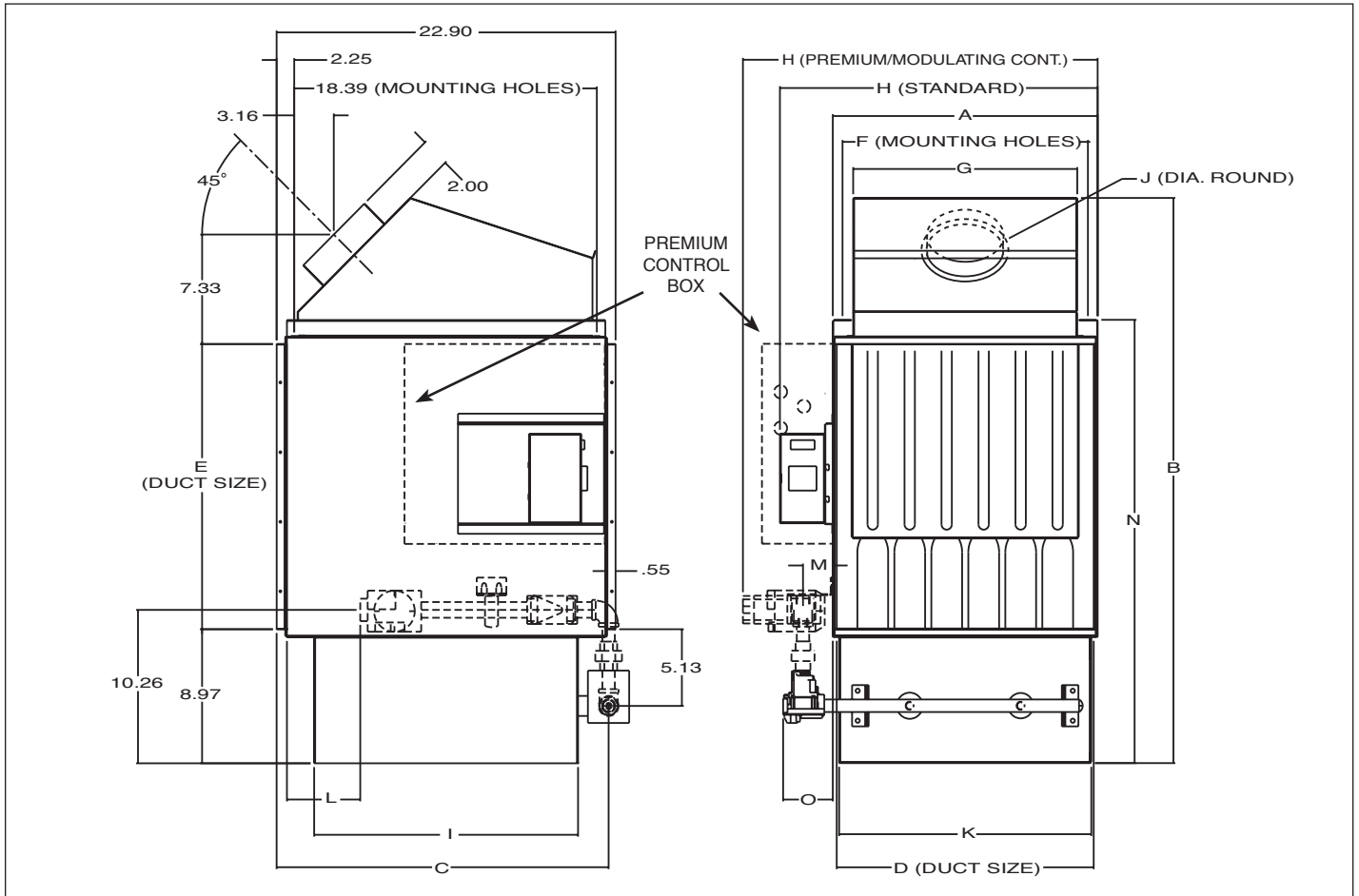

Table 9.1
Indoor Gravity Vented Duct Furnace Dimensions (DFG)

(All dimensions in inches)

Dimensions	Model Size					
	75	100/125	150/175	200/225	250/300	350/400
A	15.41	17.90	22.16	24.29	27.33	38.83
B	37.80	37.80	37.80	41.80	41.80	41.80
C	22.43	22.43	22.43	24.09	24.09	24.09
D	15.21	17.70	21.96	24.09	27.13	38.63
E	19.07	19.07	19.07	23.07	23.07	23.07
F	14.09	16.59	20.85	22.98	26.01	37.51
G	12.65	15.14	19.41	21.60	24.60	36.14
H (standard)	18.98	21.47	25.73	28.06	31.40	42.40
H (premium/modulating cont.)	21.48	23.97	28.24	30.30	33.31	44.84
I	17.83	17.83	17.83	20.68	20.68	20.68
J	5	6	7	7	8/10	10
K	14.55	17.04	21.31	23.26	26.44	37.80
L (min. approx.)	5.0	5.0	5.0	6.6/6.1	6.1	6.1/5.8
M	2.01	2.01	2.01	1.94	1.94	1.94
N	29.65	29.65	29.65	33.65	33.65	33.65
O (max. approx.)	5.6	5.6	5.6	6.8/6.2	6.2	8.3/8.6
Gas Connection Pipe Size (max. std.)	1/2	1/2	1/2	1/2 / 3/4	3/4	3/4
Gas Connection Pipe Size (max. prem.)	3/4	3/4	3/4	3/4	3/4	3/4
Approx. Weight (lbs.)	Unit Shipping	89	113	140	175	284
	Unit Net	73	95	121	155	251

Figure 10.1
Indoor Power Vented Duct Furnace Dimensions

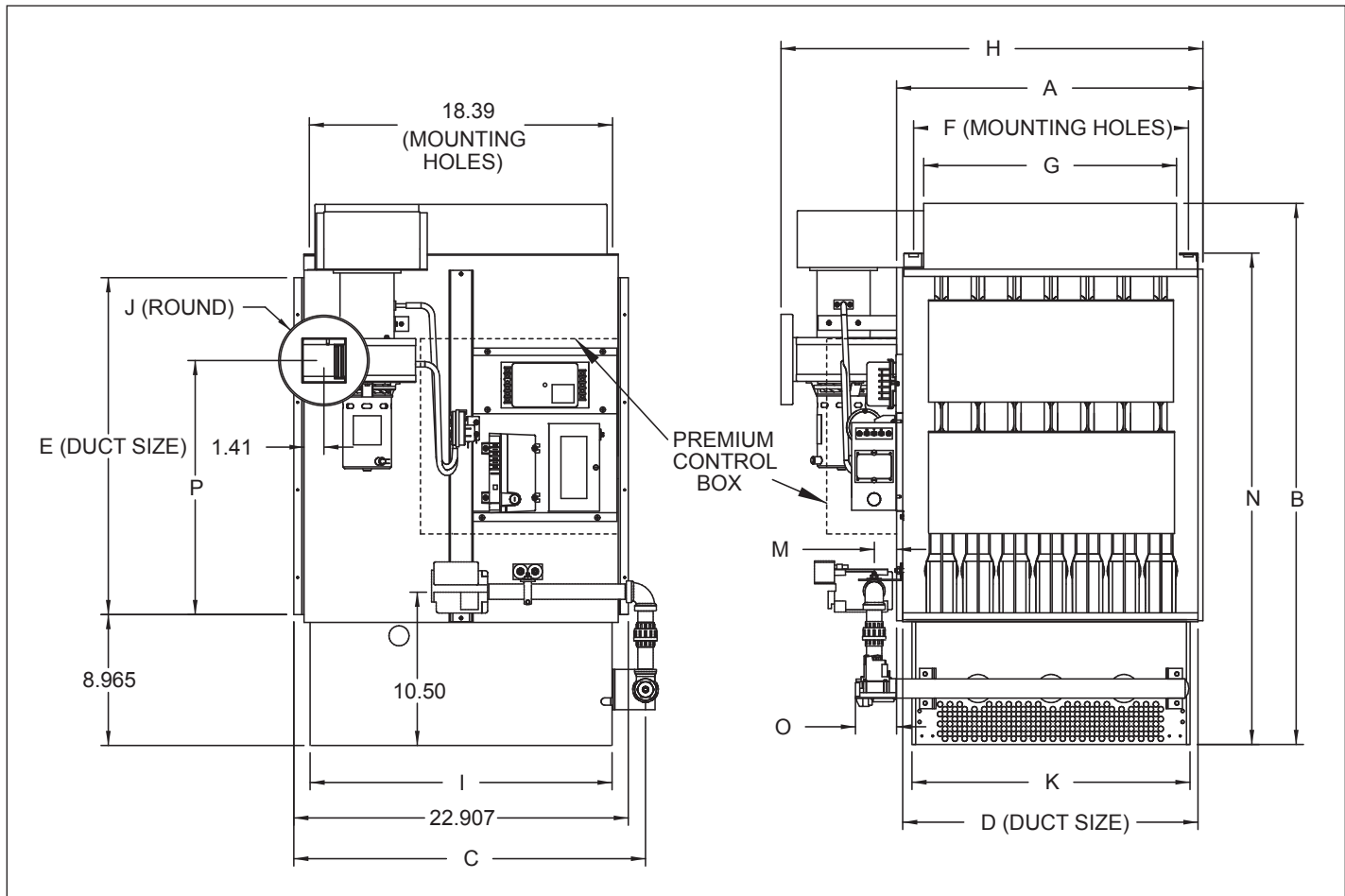

Table 10.1
Indoor Power Vented Duct Furnace Dimensions

(All Dimensions in inches)

Dimensions	Model Size						
	75	100/125	150/175	200/225	250/300	350/400	
A	15.41	17.90	22.16	24.29	27.33	38.83	
B	33.05	33.05	33.05	37.05	37.05	37.05	
C (standard)	22.43	22.43	22.43	24.09	24.09	24.09	
D	15.21	17.70	21.96	24.09	27.13	38.63	
E	19.07	19.07	19.07	23.07	23.07	23.07	
F	14.09	16.59	20.85	22.98	26.01	37.51	
G	12.65	15.14	19.41	21.60	24.60	36.14	
H	23.75	26.26	30.51	32.78	35.79	47.32	
I	17.83	17.83	17.83	20.68	20.68	20.68	
J	4	4	4	6	6	6	
K	14.55	17.04	21.31	23.26	26.44	37.80	
M	2.01	2.01	2.01	1.94	1.94	1.94	
N	29.65	29.65	29.65	33.65	33.65	33.65	
O (max. approx.) (standard)	5.6	5.6	5.6	6.8/6.2	6.2	8.3/8.6	
P	14.03	14.03	14.03	17.40	17.40	17.40	
Gas Connection Pipe Size (max. std.)	1/2	1/2	1/2	1/2 / 3/4	3/4	3/4	
Gas Connection Pipe Size (max. prem.)	3/4	3/4	3/4	3/4	3/4	3/4	
Approx. Weight (lbs.)	Unit Shipping	101	125	152	187	225	296
	Unit Net	85	107	133	167	193	263

Figure 11.1
Indoor Separated Combustion Duct Furnace Dimensions (DFS)

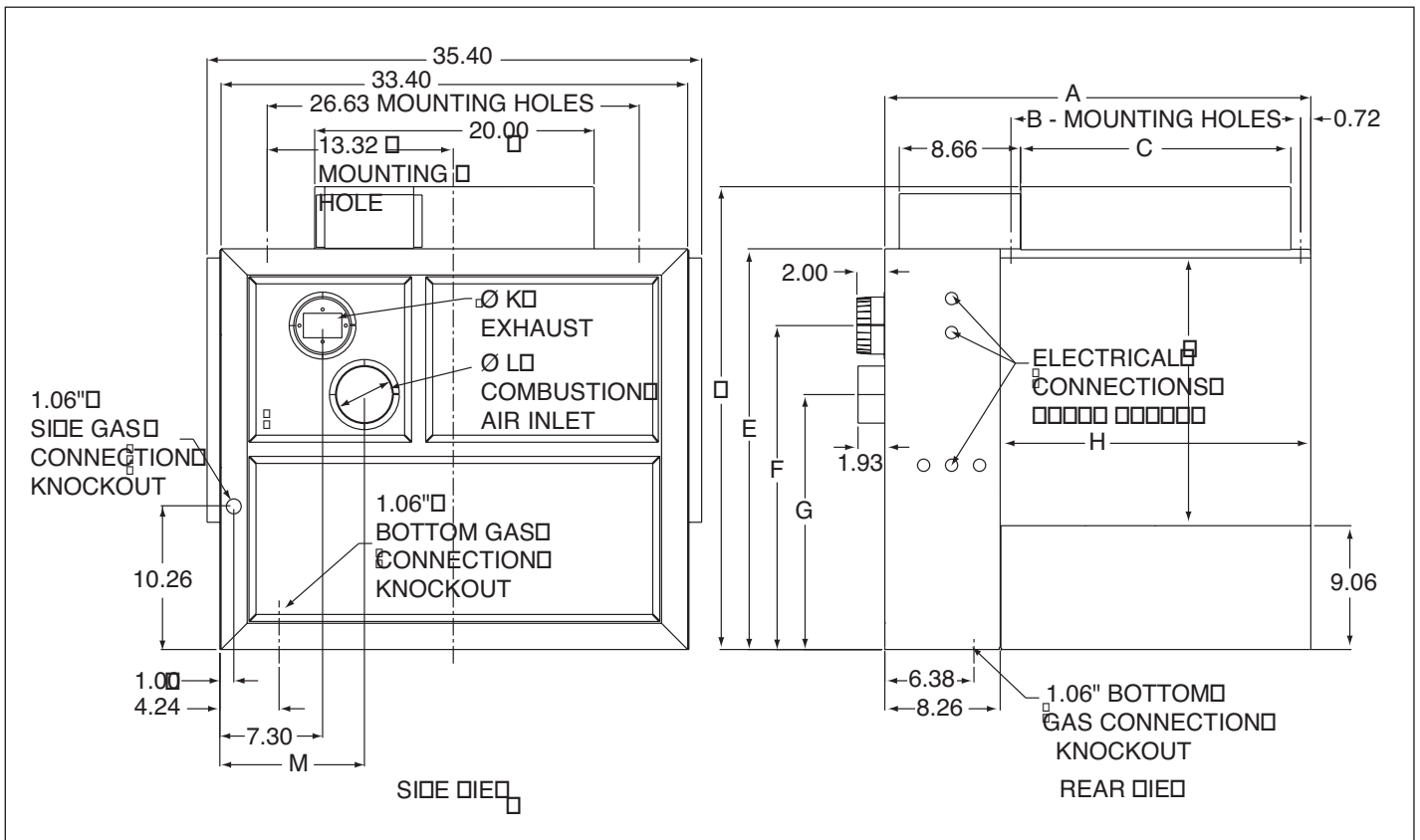

Table 11.1
Indoor Separated Combustion Duct Furnace Dimensions (DFS)
 (All dimensions in inches)

Dimension	Model Size					
	75	100/125	150/175	200/225	250/300	350/400
A	23.74	26.24	30.50	32.60	35.60	47.14
B	13.98	16.48	20.74	22.85	25.85	37.39
C	12.58	15.08	19.34	21.45	24.48	36.00
D	33.04	33.04	33.04	37.04	37.04	37.04
E	28.61	28.61	28.61	32.61	32.61	32.61
F	23.08	23.08	23.08	26.43	26.43	26.43
G	18.19	18.19	18.19	19.21	19.21	19.21
H (duct width)	15.12	17.62	21.88	23.99	26.99	38.53
J (duct height)	18.90	18.90	18.90	22.90	22.90	22.90
K ①	3.86	3.86	3.86	5.86	5.86	5.86
L ①	4.17	4.17	4.17	6.18	6.18	6.18
M	10.26	10.26	10.26	9.60	9.60	9.60
Gas Connection Pipe Size		1/2"	1/2"	1/2"	3/4"	3/4"
Approx. Weight (lbs.)	Unit Shipping	226	250	273	325	454
	Unit Net	151	170	188	230	329

① Nominal vent pipe size is 4" (Models 75-175) and 6" (Models 200-400). Exhaust pipe installed over collar. Combustion air pipe installed inside collar.

Figure 12.1 - Outdoor Gravity Vented Duct Furnace Dimensions (HFG)

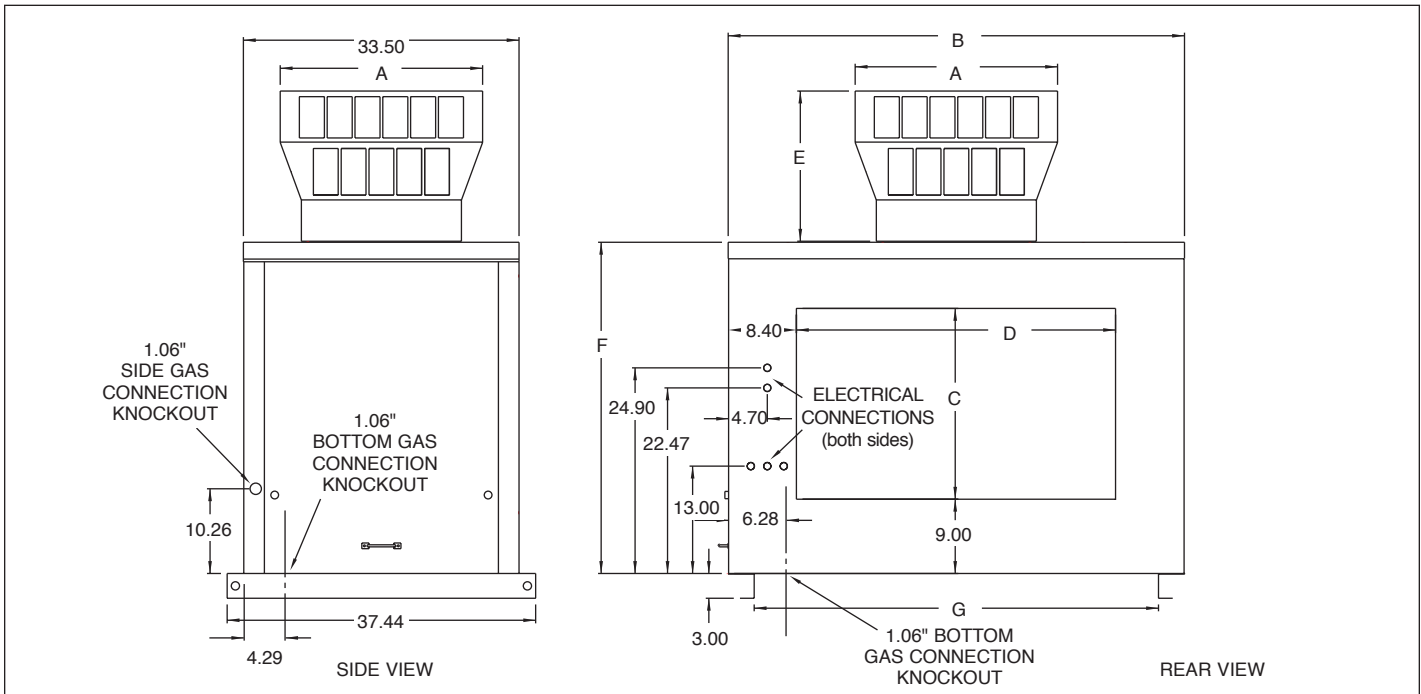

Figure 12.2 Rail or Slab Type Mounting Base

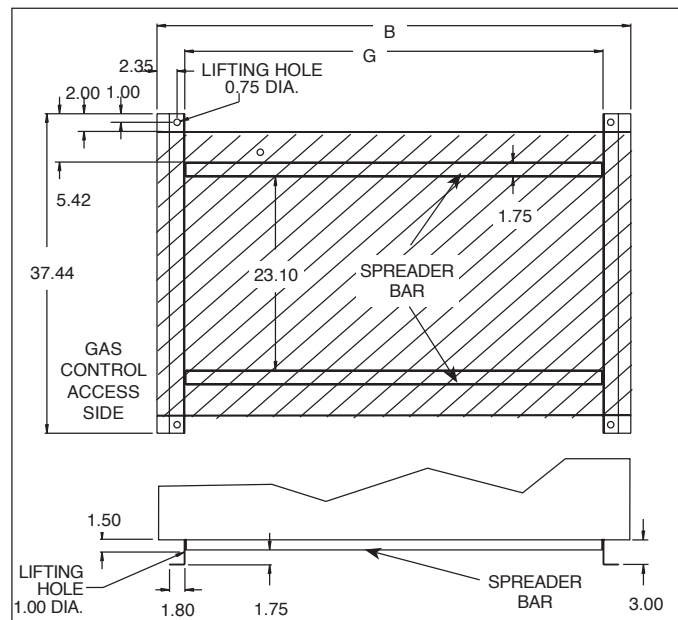
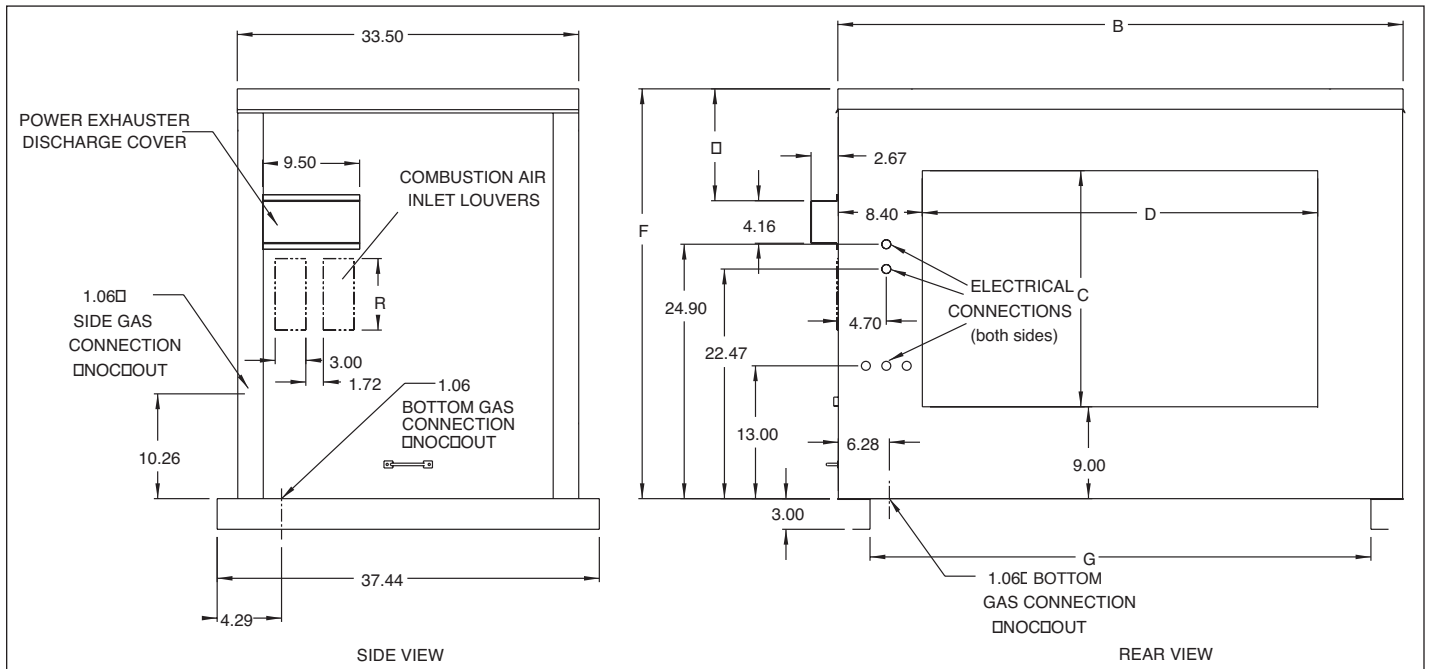
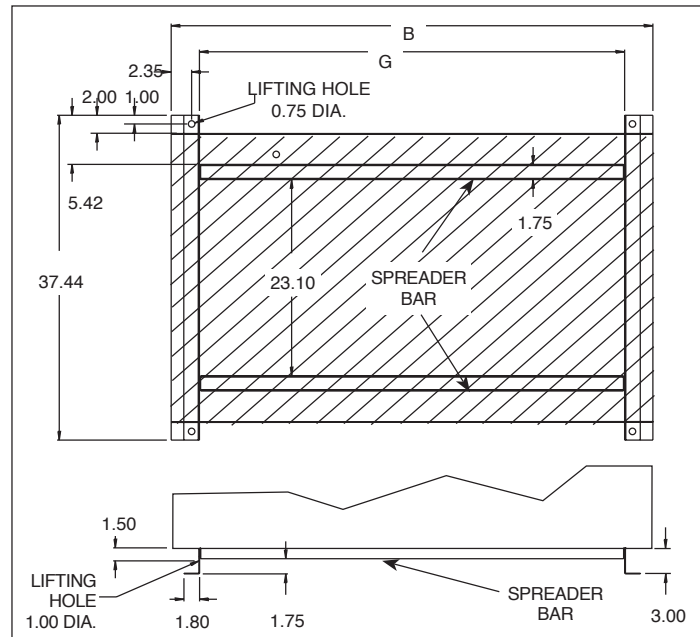

Table 12.1 Outdoor Gravity Vented Duct Furnace Dimensions (HFG) (All dimensions in inches)

Model Size	75	100/125	150/175	200/225	250/300	350/400
A	19.22	19.22	19.22	19.22	21.31	24.64
B	31.96	34.46	38.72	40.84	43.86	55.38
C (duct height)	18.98	18.98	18.98	22.98	22.98	22.98
D (duct width)	15.18	17.69	21.94	24.06	27.09	38.60
E	14.20	14.20	14.20	14.20	15.18	18.38
F	36.11	36.11	36.11	40.11	40.11	40.11
G	25.50	28.00	32.25	34.38	37.40	48.92
Gas Connection Pipe Size	1/2"	1/2"	1/2"	1/2"	3/4"	3/4"
Approx. Weight (lbs.)	Unit Shipping	282	305	333	383	525
	Unit Net	207	225	248	288	400
	Cap Net	16	16	16	16	26

Figure 13.1 - Outdoor Power Exhausted Duct Furnace Dimensions (HFP)

**Figure 13.2
Rail or Slab Type Mounting Base**

**Table 13.1
Outdoor Power Vented Duct Furnace Dimensions (HFP) (All dimensions in inches)**

Model Size	75	100/125	150/175	200/225	250/300	350/400
B	31.96	34.46	38.72	40.84	43.86	55.38
C (duct height)	18.98	18.98	18.98	22.98	22.98	22.98
D (duct width)	15.18	17.69	21.94	24.06	27.09	38.60
F	36.11	36.11	36.11	40.11	40.11	40.11
G	25.50	28.00	32.25	34.38	37.40	48.92
Q	10.95	10.95	10.95	11.58	11.58	11.58
R	7	7	7	9.9	9.9	9.9
Gas Connection Pipe Size	1/2"	1/2"	1/2"	1/2"	3/4"	3/4"
Approx. Weight (lbs.)	Unit Shipping	292	315	343	398	540
	Unit Net	217	235	258	303	415

Indoor Gravity Vented (DGB/DCG)

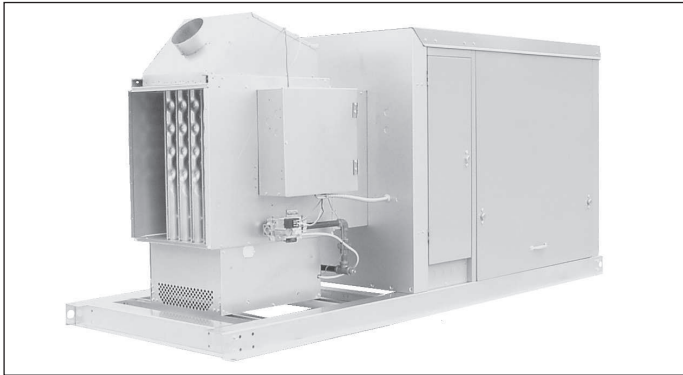
The indoor gravity vented duct furnace with blower, and/or cooling sections was designed for use with a building's heating, heating/ventilating/cooling and make-up air systems. They have input ranges from 75,000 to 1,200,000 Btu/Hr and can operate on either natural or propane gas. The airflow ranges from 556 to 14,500 CFM and the airflow direction can be specified when ordering the unit. The unit can be provided with a cooling coil section with either a factory installed DX or chilled water cooling coil or the coil can be provided by others.

Figure 14.1 - Indoor Gravity Vented Duct Furnace with Blower Section (DBG)



Indoor Power Vented (DBP/DCP)

Models DBP and DCP include all the items featured for Model DBG and DCG, but adds an integral power exhaust that allows for:

- Vertical or horizontal venting with the smallest diameter vent pipe possible.
- The ability to overcome reasonable negative pressures seen in buildings with inadequate make up air.
- Improved building efficiency through the reduction of off-cycle vent losses.

Figure 14.2 - Indoor Power Vented Duct Furnace with Blower Section and Cooling Coil Cabinet (DCP)

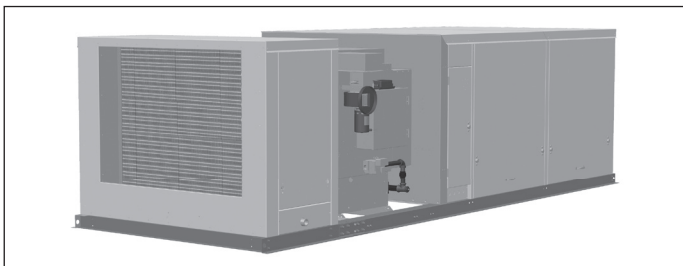

Indoor Separated Combustion (DBS/DCS)

Model DBS and DCS builds upon the advantages of the Power Vented Model DBP and DCP, but is specifically designed for buildings with hostile environments, such as dirty or high humidity applications. This model features:

- Separate electrical and gas control access with fully gasketed doors to seal components from the environment.
- Combustion air that is drawn from outside to ensure the unit has plenty of fresh, clean air.
- Since combustion air is introduced from outside, off-cycle vent losses are essentially eliminated, further improving building efficiency.
- Horizontal or vertical two-pipe or concentric venting options.

Figure 14.3 - Indoor Separated Combustion Multiple Duct Furnace with Blower Section (DBS)

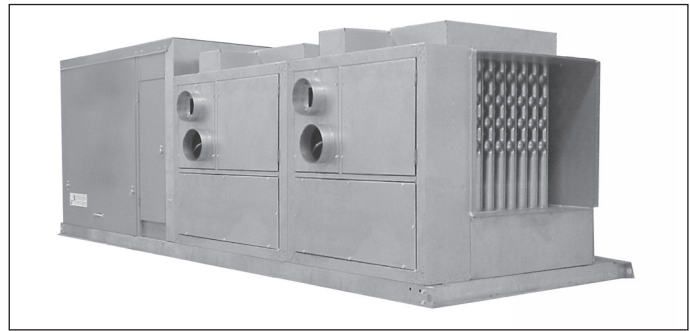

Outdoor Gravity Vented & Power Exhausted

The outdoor duct furnace with blower, cooling, and/or downturn plenum sections was designed for use with a building's heating, heating/ventilating/cooling and make-up air systems. They have input ranges from 75,000 to 1,200,000 Btu/Hr and can operate on either natural or propane gas. The airflow ranges from 556 to 14,500 CFM and the airflow direction can be specified when ordering the unit. The unit can be provided with a cooling coil section with either a factory installed DX or chilled water cooling coil or the coil can be provided by others.

Figure 14.4 - Outdoor Duct Furnace with Blower, Cooling Cabinet, and Downturn Plenum Sections (HPG)

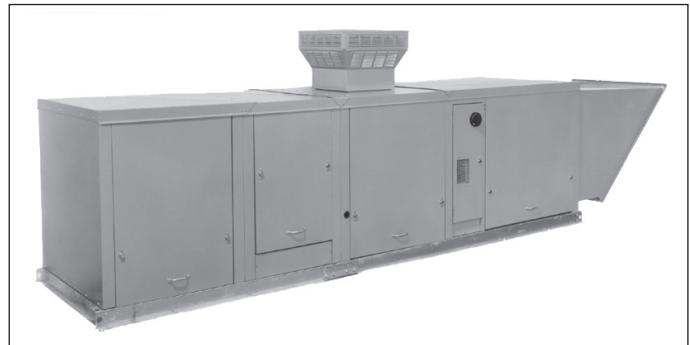

Figure 14.5 - Outdoor Multiple Duct Furnace with Blower and Downturn Plenum Sections (HDG)



Standard Features:

All duct furnace standard features as listed on page 5, with the addition of the following:

- ETL certification of the entire system unit.
- 18 gauge aluminized steel blower cabinet with a baked-on polyester powder paint finish on exterior casing parts.
- 1" Insulation for the blower and/or cooling cabinet sections (outdoor units only).
- Blower performance up to 3.0" W.C. external static pressure.
- Open drip proof blower motors.
- Separate line and low voltage terminal strips in blower electrical compartment.
- Fan time delay relay.
- Combination suspension and slab type mounting base (indoor units).
- Combination roof curb and slab type mounting base (outdoor units).
- Adjustable belt drive.
- Premium control box (DBG, DCG, DBP, DCP).

Optional Features - Factory Installed

Available with all duct furnace optional features as listed on page 5, with the addition of the following:

- Totally-enclosed and high efficiency motors.
- Motor starters with one normally open contact.
- Variable frequency drive.
- 1" or 2" permanent, 2" FARR® Aeropleat III (MERV 7) disposable, or 2" FARR® 30/30 (MERV 8) filters.
- 18 gauge aluminized steel DX or chilled water coil cabinet with a baked-on polyester powder paint finish.
- Optional factory installed cooling coil (see page 62 for CFM/performance ranges).
- 1" Insulation for the blower and/or cooling cabinet sections (standard on outdoor units).
- Double wall construction for blower, and/or cooling cabinet sections.
- Downturn plenum section with 1" insulation (outdoor units only).
- Double wall construction for downturn plenum section (outdoor units only).
- Discharge air dampers (Downturn plenum units only).
- Two position, modulating, building pressure sensing, three position, or building management (0-10VDC or 4-20mA) damper actuators.
- Economizer warm-up packages.
- Dead-front disconnect switches.
- Step-down transformers for 460/575V/3Ph.
- Left side access to blower, burner, and gas controls.
- Mild temperature thermostat.
- Supply and/or return air firestats.
- Blower door interlock switch.
- Convenience outlet.
- Blower and motor vibration isolation.
- Pillow block bearings.
- Extended grease lines.
- Burner/blower/damper service switches.
- 6 or 10 point circuit analyzer.
- Evaporative cooling section (outdoor units only).

Accessories - Field Installed

Available with all duct furnace accessory features as listed on page 5, with the addition of the following:

- Remote control panels.
- Evaporative cooler fill and drain kits (units with evaporative coolers only).
- Insulated roof curbs (outdoor units only).
- Roof curb discharge and return air connection kits (outdoor units only).

SYSTEM UNIT PERFORMANCE DATA



Table 16.1
General Performance Data - Models With Blower

Model Size (Digits 4-6)	75		100		125		150		175	
Btu/Hr Input ①	75,000	75,000	100,000	100,000	125,000	125,000	150,000	150,000	175,000	175,000
Btu/Hr Output ①	60,000	60,000	80,000	80,000	100,000	100,000	120,000	120,000	140,000	140,000
Blower Style (Digit 16 Letter)	A or B	C or D	C or D	E or F	C or D	E or F	C or D	E or F	C or D	E or F
Max. Temp. Rise (°F)	100	100	100	85	100	100	100	100	100	100
Min. Temp. Rise (°F)	28	20	21	20	27	20	33	20	39	23
Max. CFM ②	1980	2778	3450	3704	3450	4630	3350	5556	3350	5556
Min. CFM ② ③	556	556	741	875	926	926	1111	1111	1296	1296

Model Size (Digits 4-6)	200			225			250		
Btu/Hr Input ①	200,000	200,000	200,000	225,000	225,000	225,000	250,000	250,000	250,000
Btu/Hr Output ①	160,000	160,000	160,000	180,000	180,000	180,000	200,000	200,000	200,000
Blower Style (Digit 16 Letter)	C or D	E or F	G or H	C or D	E or F	G or H	E or F	G or H	I, J, or K
Max. Temp. Rise (°F)	100	85	85	100	95	95	100	100	96
Min. Temp. Rise (°F)	44	28	23	49	32	26	31	26	20
Max. CFM ②	3400	5250	6500	3400	5250	6500	6000	7250	9259
Min. CFM ② ③	1481	1750	1750	1667	1750	1750	1852	1852	1925

Model Size (Digits 4-6)	300			350			400		
Btu/Hr Input ①	300,000	300,000	300,000	350,000	350,000	350,000	400,000	400,000	400,000
Btu/Hr Output ①	240,000	240,000	240,000	280,000	280,000	280,000	320,000	320,000	320,000
Blower Style (Digit 16 Letter)	E or F	G or H	I, J, or K	E or F	G or H	I, J, or K	E or F	G or H	I, J, or K
Max. Temp. Rise (°F)	100	100	100	100	100	100	100	100	100
Min. Temp. Rise (°F)	37	31	20	45	37	22	52	42	25
Max. CFM ②	6000	7250	11111	5700	7000	12000	5700	7000	12000
Min. CFM ② ③	2222	2222	2222	2593	2593	2593	2963	2963	2963

Model Size (Digits 4-6)	500			600			700		
Btu/Hr Input ①	500,000	500,000	500,000	600,000	600,000	600,000	700,000	700,000	700,000
Btu/Hr Output ①	400,000	400,000	400,000	480,000	480,000	480,000	560,000	560,000	560,000
Blower Style (Digit 16 Letter)	G or H	I, J, or K	L	G or H	I, J, or K	L	G or H	I, J, or K	L
Max. Temp. Rise (°F)	120	120	120	120	120	120	120	120	120
Min. Temp. Rise (°F)	53	40	40	63	40	40	76	40	40
Max. CFM	7000	9259	9259	7000	11111	11111	6850	12963	12963
Min. CFM ③	3086	3086	3086	3704	3704	3704	4321	4321	4321

Model Size (Digits 4-6)	800			840		960	
Btu/Hr Input ①	800,000	800,000	800,000	1,050,000	1,050,000	1,200,000	1,200,000
Btu/Hr Output ①	640,000	640,000	640,000	840,000	840,000	960,000	960,000
Blower Style (Digit 16 Letter)	G or H	I, J, or K	L	I, J, or K	L	I, J, or K	L
Max. Temp. Rise (°F)	120	120	120	120	120	120	120
Min. Temp. Rise (°F)	87	46	41	60	60	68	63
Max. CFM	6850	13000	14500	12963	12963	13000	14500
Min. CFM ③	4938	4938	4938	6481	6481	7407	7407

① Ratings are shown for elevations up to 2000 ft. For higher elevations the input rating should be reduced at the rate of 4% for each 1000 feet above sea level. For Canada, in elevations between 2000 and 4500 feet, the unit must be derated to 90% of the rating listed above.

② For Cooling capacities see page 62.

③ For Variable Air Movement Applications, see page 20.



Table 17.1
Air Temperature Rise

Btu/Hr ①		Air Temperature Rise through Unit (°F)																
Input	Output	20	25	30	35	40	45	50	55	60	65	70	75	80	85	90	95	100
		Max	CFM															Min②
75,000	60,000	2778	2222	1852	1587	1389	1235	1111	1010	926	855	794	741	694	654	617	585	556
100,000	80,000	3704	2963	2469	2116	1852	1646	1481	1347	1235	1140	1058	988	926	871	823	780	741
125,000	100,000	4630	3704	3086	2646	2315	2058	1852	1684	1543	1425	1323	1235	1157	1089	1029	975	926
150,000	120,000	5556	4444	3704	3175	2778	2469	2222	2020	1852	1709	1587	1481	1389	1307	1235	1170	1111
175,000	140,000	-	5185	4321	3704	3241	2881	2593	2357	2160	1994	1852	1728	1620	1525	1440	1365	1296
200,000	160,000	-	5926	4938	4233	3704	3292	2963	2694	2469	2279	2116	1975	1852	1743	1646	1559	1481
225,000	180,000	-	6667	5556	4762	4167	3704	3333	3030	2778	2564	2381	2222	2083	1961	1852	1754	1667
250,000	200,000	9259	7407	6173	5291	4630	4115	3704	3367	3086	2849	2646	2469	2315	2179	2058	1949	1852
300,000	240,000	11111	8889	7407	6349	5556	4938	4444	4040	3704	3419	3175	2963	2778	2614	2469	2339	2222
350,000	280,000	-	10370	8642	7407	6481	5761	5185	4714	4321	3989	3704	3457	3241	3050	2881	2729	2593
400,000	320,000	-	11852	9877	8466	7407	6584	5926	5387	4938	4558	4233	3951	3704	3486	3292	3119	2963

Btu/Hr ①		Air Temperature Rise through Unit (°F)																
Input	Output	40	45	50	55	60	65	70	75	80	85	90	95	100	105	110	115	120
		Max	CFM															Min②
500,000	400,000	9259	8230	7407	6734	6173	5698	5291	4938	4630	4357	4115	3899	3704	3527	3367	3221	3086
600,000	480,000	11111	9877	8889	8081	7407	6838	6349	5926	5556	5229	4938	4678	4444	4233	4040	3865	3704
700,000	560,000	12963	11523	10370	9428	8642	7977	7407	6914	6481	6100	5761	5458	5185	4938	4714	4509	4321
800,000	640,000	14500	13000	11852	10774	9877	9117	8466	7901	7407	6972	6584	6238	5926	5644	5387	5153	4938
1,050,000	840,000	-	-	-	-	12963	11966	11111	10370	9722	9150	8642	8187	7778	7407	7071	6763	6481
1,200,000	960,000	-	-	-	-	-	13675	12698	11852	11111	10458	9877	9357	8889	8466	8081	7729	7407

① Ratings are shown for elevations up to 2000 ft. For higher elevations the input rating should be reduced at the rate of 4% for each 1000 feet above sea level. For Canada, in elevations between 2000 and 4500 feet, the unit must be derated to 90% of the rating listed above.

② For Variable Air Movement Applications, see page 20.

Air Temperature Limits

The maximum allowable discharge air temperature is 150°F. The maximum allowable air temperature rise per furnace for Low Air Temperature Rise Units is 60°F. All system units are designed for a maximum allowable total static pressure of 3.0" W.C.

Model Digit Descriptions

Once the first six digits of the model number have been determined from model nomenclature, page 75, the pages 18 through 22 detail the specification of the additional model number digits. For the complete model nomenclature description see page 75.

Digit 7

Heat Exchanger/Burner/Drip Pan Material (HE)

Specifies the material for the heat exchanger, burner, and drip pan material. A 409 stainless steel heat exchanger and burner is recommended when the unit is installed downstream of a cooling coil or evaporative cooler, or when combined entering/return air to the unit is below 40°F.

- A = Aluminized steel heat exchanger, burner, and drip pan
- S = 409 Stainless steel heat exchanger and burner and an aluminized steel drip pan
- T = 409 Stainless steel heat exchanger, burner and drip pan

Digit 8

Development Sequence (DS)

Used for internal factory purposes to indicate the style of controls used on the unit.

- F = Single stage gas controls
- M = Two stage or electronic modulating

Digit 9

Access Side (AS)

Determines the side of the unit on which the controls are accessed. The control side is determined by looking in the discharge of the unit (air blowing into your face) and then specifying the access side (right or left hand). Includes access to gas controls, vent connections, electrical control wiring, motor and motor sheave adjustment, the damper motor, and linkage adjustment. For duct furnaces it also indicates the discharge side of the unit for any optionally mounted discharge air components.

- R = Right Hand
- L = Left Hand

Digit 10

Air Temperature Rise (ATR)

Indicates the temperature range of each duct furnace.

For Indoor Gravity Vented Duct Furnaces:

All Units are factory supplied with an air distribution baffle to direct the air toward the bottom of the heat exchanger where the heat exchanger tubes are the warmest. The baffle is required because of the low air volume (CFM) that is going through the duct furnace. This applies to units having an air temperature rise from 60 to 100°F. If the application will be operating with an air temperature rise less than 60°F it is recommended that the baffle be removed in the field to reduce pressure drop through the unit. Select N for this digit.

For Separated Combustion and Outdoor Duct Furnaces:

High air temperature rise units (20°-100°F) include an air distribution baffle to direct the air toward the bottom of the heat exchanger where the heat exchanger tubes are the warmest. The baffle is required because of the low air volume (CFM) that is going through the duct furnace. The primary restrictor plate is factory sized to provide the 80% efficiency of the unit. High air temperature rise units are certified to be used at down to a 20°F rise, however, it is recommended to use them from the 60°-100°F range to reduce the system pressure drop. Low air temperature rise units do not include an air distribution baffle and thus the pressure drop of the unit is reduced. However, the primary restrictor plate is factory sized to provide the 80% efficiency of the unit.

For System Units:

The primary restrictor is changed for separated combustion and outdoor units to provide the 80% efficiency of the unit. For gravity vented no changes are made. The blower section transition insures the proper distribution of the airflow across the heat exchanger.

Multiple Furnace Units 500-960

For Models DBG500-960, Digit 10=N

For Models DBS/HBG/HBP/HDG/HDP500-960, Digit 10=L

Specifying the Air Temperature Rise for Variable Air Movement Applications (Separated Combustion and Outdoor Only)

The selection of the unit should be based on the low speed temperature rise of the unit. Thus, if the high speed air temperature rise is 40°F and the low speed air temperature rise is 80°F, a high air temperature rise unit should be selected.

- H = High Temperature Rise - 20°-100°F
- L = Low Temperature Rise - 20°-60°F

Digit 11

Gas Type (GT)

Determines the type of gas that will be used with the unit and the style of ignition controller. The type of gas determines the orifices used on the unit. The orifices are sized for elevations up to 2000 feet. For United States elevations of 2000 feet or greater, specify this at the time of ordering and the unit will be derated 4% per 1000 feet of elevation. In Canada for elevations of 2000 to 4500 feet, the unit is derated 10%.

N = Natural gas with continuous retry ignition controller

A 100% shut-off with continuous retry ignition controller is used. On a call for heat, the system will attempt to light the pilot for 70 seconds. If the pilot is not sensed for any reason, the ignition control will wait for approximately six minutes with the combination gas control closed and no spark. After six minutes, the cycle will begin again. After three cycles, some ignition controllers lockout for approximately one hour before the cycle begins again. This will continue indefinitely until the pilot flame is sensed or power is interrupted to the system.

P = Propane gas with continuous retry ignition controller (Gravity vented and separated combustion indoor units)

A 100% shut-off with continuous retry ignition controller is used. On a call for heat, the system will attempt to light the pilot for 70 seconds. If the pilot is not sensed for any reason, the ignition control will wait for approximately six minutes with the combination gas control closed and no spark. After six minutes, the cycle will begin again. After three cycles, some ignition controllers lockout for approximately one hour before the cycle begins again. This will continue indefinitely until the pilot flame is sensed or power is interrupted to the system.

P = Propane gas with lockout ignition controller (Outdoor units)

For propane gas units, a 100% shut-off with lockout ignition controller is used. On a call for heat, the system will attempt to light the pilot for 70 seconds. If the pilot is not sensed for any reason, the ignition control will lockout, the pilot gas valve will shut off and the sparking will cease. The system will not attempt to relight until power has been interrupted to the controls and the controls are reset via the thermostat.

Digit 12

Gas Valve (GV)

Determines the type of gas valve provided with each unit.

1 = Single-stage

Single-stage gas controls utilize a single-stage combination gas control, an ignition control, and a single-stage low voltage thermostat. The unit fires at 100% full fire based on a call for heat from a room thermostat (thermostat ordered separately).

2 = Two-stage

Two-stage gas controls utilize a two-stage combination gas control, an ignition control, and a two-stage low voltage thermostat. The unit fires at 50% fire on low stage or 100% fire on high stage of the unit based on the call for heat from either a room or duct thermostat (thermostat ordered separately).

4 = Electronic Modulation

Electronic modulation gas controls utilize an electronic modulating/regulating gas control, combination gas valve, an ignition control, modulating amplifier and either a modulating room thermostat or modulating duct thermostat with remote temperature set point adjuster. The thermostat can modulate the system gas flow between 40% and 100% full fire. Requires the addition of either the room or duct electronic modulating thermostat.

When the duct thermostat is utilized, a room override thermostat can be added. When calling for heat, the room override thermostat provides full fire operation until the space temperature is satisfied. Control is then returned to the duct sensing control. In this situation, either the duct thermostat or the room override thermostat can call for heat.

5 = Electronic Modulation - Master (duct furnaces only)

Used in higher Btu/Hr input applications where more than one duct furnace is being used with electronic modulating gas controls. Allows one duct sensing thermostat to control the firing rate of the Master duct furnace and up to three Slave duct furnaces (See 6 = Slave). Utilizes the same controls as described in 4 = Electronic Modulation, except that a single duct furnace amplifier is replaced by a multiple furnace amplifier. The multiple furnace amplifier sends a signal to all of the gas valves so that they modulate at the same percentage. When the thermostat is satisfied, the amplifier cuts power to the combination gas valves of the Master unit and all Slave units, which prevents gas flow to both the main and pilot burners.

6 = Electronic Modulation - Slave (duct furnaces only)

Requires one Master unit. The Slave furnace includes an electronic modulating/regulating gas control, combination gas valve, and an ignition control, but no modulating amplifier and does not require a discharge air thermostat. The modulating gas valve receives the modulation percentage from the Master duct furnace. Up to three Slave duct furnaces can be connected to one Master unit.

7 = Electronic Modulation - 0-10 Vdc External Input

Allows for control of the duct furnace firing rate by a Building Management System (BMS). Utilizes an electronic modulating/regulating gas control, combination gas valve, an ignition control, modulating signal conditioner, and an inverted 0-10 Vdc input signal provided by a BMS (0 Vdc being high fire and 10 Vdc being low fire). The signal conditioner can modulate the gas flow between 40% and 100% full fire. When the BMS thermostat (supplied by others) is satisfied, the BMS heat contact (supplied by others) opens to cut power to the combination gas valve which prevents gas flow to both the main and pilot burners.

8 = Electronic Modulation - 4-20 mA External Input

Allows for control of the duct furnace firing rate by a Building Management System (BMS). Utilizes an electronic modulating/regulating gas control, combination gas valve, an ignition control, modulating signal conditioner, and an inverted 4-20 mA input signal provided by a BMS (4 mA being high fire and 20 mA being low fire). The signal conditioner can modulate the gas flow between 40% and 100% full fire. When the BMS thermostat (supplied by others) is satisfied, the BMS heat contact (supplied by others) opens to cut power to the combination gas valve which prevents gas flow to both the main and pilot burners.

Digit 13

Additional Safety Switches (SS)

Provides additional gas train safety devices.

A low gas pressure switch monitors the gas supply pressure ahead of all the gas controls and shuts off the electric supply to the ignition controller and combination gas valve if low gas pressure is experienced. This will shut off all gas flow to the burner. If the gas pressure to the unit is below the normal operating pressure, the burner

could have difficulty lighting properly. The switch has an automatic reset so that if the gas pressure is interrupted and then returned, the switch will automatically allow the unit to operate when gas conditions are returned to the allowable range of the pressure switch. A high gas pressure switch monitors the gas supply pressure downstream of all the gas controls and shuts off the electric supply to the ignition controller and combination gas valve if high gas pressure is experienced right before the manifold. This will shut off all gas flow to the burner. If the gas pressure to the unit is too high, the gas controls could be damaged and cause the unit to over fire. The switch has a manual reset so that if the gas pressure is too high, a service person must check the unit to make sure that none of the gas controls have been damaged by the high gas pressure and then reset the switch to allow the unit to operate when the gas conditions are returned to the allowable range of the pressure switch.

If no additional safety switches are ordered, a standard control box may be selected for the gravity vented indoor duct furnace. This option is not available for indoor gravity vented system units, indoor separated combustion units or outdoor units, all which require the use of the premium Control box.

0 = No Additional Safety Switches (Premium Control Box)

1 = Low Gas Pressure Switch (Premium Control Box)

2 = High Gas Pressure Switch (Premium Control Box)

3 = High and Low Gas Pressure Switch (Premium Control Box)

4 = No Additional Safety Switches (Standard Control Box)

Digit 14

Supply Voltage (SV)

Indicates the supply voltage for the unit. For duct furnace units, this specifies the line voltage to 24V control transformer that will be provided with the unit. For system units, this specifies the control transformer voltage in addition to the blower motor voltage.

A = 115V/60Hz/1Ph

E = 230V/60Hz/3Ph

B = 208V/60Hz/1Ph

F = 460V/60Hz/3Ph

C = 230V/60Hz/1Ph

G = 575V/60Hz/3Ph

D = 208V/60Hz/3Ph

Digit 15

Transformer (TR)

Indicates the size of the step-down transformer that converts line voltage power to low voltage for use with the gas controls. The transformer size is rated in volt-amperes (VA). 40 VA transformers are Class II with integral fusing. 75 VA transformers are Class II with a 3.2A circuit breaker. 150 VA and 250 VA transformers include separate primary fusing. The size of the transformer should be specified based on Table 19.1.

1 = 40 VA

4 = 250 VA ①

2 = 75 VA ①

0 = None

3 = 150 VA ①

Table 19.1

Gas Control Transformer Sizing

Model Size	Unit Type	Controlling	Digit 15
75-400	Non Master Duct Furnace		1
	Master Duct Furnace	1 Slave ①	2
	Master Duct Furnace	2 Slaves ②	3
	Master Duct Furnace	3 Slaves ②	3
	Slave Duct Furnace		0
	All System Units		2
500-800	All		3
840-960	Digit 12 = 1, 2, or 3		3
	Digit 12 = 4, 7, or 8		4

① Digit 13 must equal 0,1,2, or 3

② When Digit 14 = F or G, Digit 13 must equal 0,1,2, or 3

Note: When specifying a duct furnace, only the first fifteen digits of the model need to be specified. The additional eight digits are for System units.



Digit 16

Blower Size and Bearing Type (BB)

All System units are offered with at least two blower sizes available with the units 200,000 Btu/Hr input and greater offering three blower sizes (See Table 16.1). To determine the proper blower size, review the blower performance curves for the desired model size and insure that the required CFM and total static pressure (internal static pressure + external static pressure) are on the curve selected. For additional information on determining the proper blower size, review the Sizing and Selection Example on pages 34 and 35.

The blower assembly is available with either spider bearings or greaseable pillow block ball bearings. The spider bearing option includes blower mounted bearing brackets with ball bearings. Spider bearings are designed for use in low blower RPM and low motor horsepower applications. For units where Digit 16 is A, C, E, or G, the recommended limits are 1900 blower RPM and a 5 Hp motor. For units where Digit 16 = I, the required limits are 1200 blower RPM and a 10 Hp motor.

The pillow block bearing option includes two heavy duty pillow block bearing housings with internal ball bearings that are rigidly fastened to two 18 gauge minimum blower support channels. Pillow block bearings are available for all applications, but are required for high blower rpm and high motor horsepower applications that exceed the spider bearing limits.

- A = 9-7 blower wheel with spider bearings
- B = 9-7 blower wheel with pillow block bearings
- C = 9-9 blower wheel with spider bearings
- D = 9-9 blower wheel with pillow block bearings
- E = 12-12 blower wheel with spider bearings
- F = 12-12 blower wheel with pillow block bearings
- G = 15-15 blower wheel with spider bearings
- H = 15-15 blower wheel with pillow block bearings
- I = 18-18 blower wheel with spider bearings under 15 Hp
- J = 18-18 blower wheel with pillow block bearings under 15 Hp
- K = 18-18 blower wheel with pillow block bearings for 15 Hp & up
- L = 20-18 blower wheel with pillow block bearings

Digit 17

Motor Horsepower (HP)

The required motor horsepower is determined by the required CFM and total static pressure (internal static pressure + external static pressure) when plotted on the blower performance curve selected. When determining the motor horsepower, always select the motor horsepower to the right of the job conditions. For additional information on selecting the proper motor horsepower, review the Sizing and Selection Example on pages 34 and 35. Refer to pages 42 through 44 to determine if the selected motor has thermal overload protection. Motors that do not have internal thermal overload protection and all three phase motors, require a motor starter that is either factory installed or supplied by others and field installed.

- | | |
|--------------|---------------------------------|
| A = 1/3 Hp | L = 1/3 Hp with motor starter |
| B = 1/2 Hp | M = 1/2 Hp with motor starter |
| C = 3/4 Hp | N = 3/4 Hp with motor starter |
| D = 1 Hp | P = 1 Hp with motor starter |
| E = 1-1/2 Hp | Q = 1-1/2 Hp with motor starter |
| F = 2 Hp | R = 2 Hp with motor starter |
| G = 3 Hp | S = 3 Hp with motor starter |
| H = 5 Hp | T = 5 Hp with motor starter |
| I = 7-1/2 Hp | W = 7-1/2 Hp with motor starter |
| J = 10 Hp | X = 10 Hp with motor starter |
| K = 15 Hp | Y = 15 Hp with motor starter |
| V = 20 Hp | Z = 20 Hp with motor starter |

Digit 18

Motor Type (MT)

Blower motors are available in Open Drip Proof (ODP), Totally Enclosed (TE) and High Efficiency (HE) ODP and TE. All motors are continuous duty, ball bearing type, Class "B" insulated with a rigid base. For the list of available motors based on supply voltage, refer to pages 42 through 44. These tables also include frame sizes, amp draws, service factors,

efficiencies, thermal overload protection, and weights. Motors that do not have internal thermal overload protection and all three phase motors require a motor starter that is either factory installed or supplied by others and field installed. Where applicable, all motors meet the Requirements of the Energy Policy Act of 1992.

Variable Air Volume Applications

Units may be supplied with variable frequency drives for applications where variable air volume is required. The minimum air flow may be varied between 30 and 100% of the full speed airflow depending on the controls selection of the unit. Due to the extra restrictions of the controller all selections must be performed with the AccuSpec configuration software. Within AccuSpec, three variable frequency drive speed control changeover options are available:

1. Two speed which may be controlled by a manual high/low switch which may be factory mounted on the control panel or shipped loose for field installation, or by exhaust fan interlocks.
2. Floating building pressure sensing which utilizes a photohelic pressure controller to adjust the building pressure by varying the amount of makeup air supplied to the space.
3. Building management control which allows for an external signal of 0-10VDC of 4-20mA to adjust the unit airflow.

Additionally, when the air mover supplied by others can provide variable air movement (i.e. two-speed units), the certified allowable minimum CFM of the System units can be 66% of the minimum listed CFM in Table 16.1 if the unit is applied as follows:

1. The unit is provided with two-stage or electronic modulation gas controls.
2. The unit is provided with a factory installed discharge air controller.
3. The system does not include a room thermostat.

The factory installed discharge air thermostat will prevent the unit from firing above the allowable 100°F rise when the unit is at or above the minimum CFM by monitoring the discharge air and going to low fire. A room thermostat, because it is located remote from the unit, could cause the unit to over-fire.

- 1 = Open Drip Proof (ODP)
- 2 = ODP, High Efficiency (ODP HE)
- 5 = Totally Enclosed (TE)
- 6 = TE, High Efficiency (TE HE)

Digit 19

Sheave Arrangement (SA)

All System units are provided with adjustable motor sheaves so that the blower RPM can be adjusted for slight increases or decreases in the actual job external static pressure as compared to the design external static pressure. The adjustable motor sheaves can also be used to increase or decrease the CFM of the unit. The adjustment range of the sheave is shown in the Sheave Selection Tables on page 40.

Digits 20 and 21

Air Control (AC)

The Air Control digits determine the entering air locations to the blower, the type of damper motor, and the damper motor controller. If a damper motor is provided, it is mounted directly to the shaft of the fresh air damper. If fresh air and return air dampers are provided, the two dampers are mechanically linked to provide easy adjustment at the job site. All fresh air dampers are ultra low leak, Class II leakage resistance (less than 10 CFM/ft² at 1" W.C.) dampers with self-compensating stainless steel side seals and santoprene and galvanized steel blade seals. All return air dampers, which are used for air balancing, shall be low leak, Class III leakage resistance (less than 40 CFM/ft² at 1" W.C.) dampers with self-compensating stainless steel side seals and santoprene blade seals. All damper motors are spring return (except Air Control HP), so when the damper motor is de-energized the fresh air opening is closed. All two-position damper motors contain one normally open and one normally closed end switch.

The Fresh Air and Return Air openings are defined as follows:
The fresh air opening is defined as a back inlet to the unit.
The return air opening is defined as a bottom inlet to the unit.

AA = Return Air Opening

This configuration is typically used for heating only units in which 100% of the air is recirculated from the space. In this configuration, the unit does not contain a damper and the back of the unit does not contain an opening for outside air.

BA = Fresh Air Opening

This configuration is typically used for heating only units in which 100% of the air is recirculated from the space. In this configuration, the unit does not contain a damper and the bottom of the unit does not contain an opening for return air.

CA = Fresh Air and Return Air Openings

This configuration is typically used for heating only units in which the return air will be brought to the unit from both the bottom and the back of the unit. In this configuration, the unit does not contain a damper in either opening.

DA = Fresh Air Dampers with Two-Position Damper Motor with No Return Air

This configuration is typically used for 100% make-up air units. In this configuration, the bottom of the unit does not contain an opening for return air.

EA = Fresh Air and Return Air Dampers with Two-Position Damper Motor

This configuration is typically used for heating and make-up air units that require 100% outside air during the daytime (or occupied mode) and 100% return air during the evening (or unoccupied mode). The damper motor can be energized by a switch (day/night, occupied/unoccupied, etc.) to control the damper position.

EQ = ASHRAE Cycle I - Fresh Air and Return Air Dampers with Two-Position Damper Motor with Warm-Up Thermostat

This configuration is typically used for heating and make-up air units that require 100% outside air during the daytime (or occupied mode) and 100% return air during the evening (or unoccupied mode). The damper motor can be energized by a switch (day/night, occupied/unoccupied, etc.) to control the damper position. The warm-up thermostat is provided so that when the unit is switched into the 100% outside air mode, the return air temperature is monitored and prevents the fresh air damper from opening until the temperature of the return air has reached the desired set point (usually 5°F below the room temperature).

FA = Fresh Air Dampers and Return Air Opening with Two-Position Damper Motor

This configuration is typically used for heating and make-up air units that require a mix of outside air and return air during the daytime (or occupied mode) and 100% return air during the evening (or unoccupied mode). The damper motor can be energized by a switch (day/night, occupied/unoccupied, etc.) to control the damper position.

GA = Fresh Air and Return Air Dampers with Modulating Damper Motor with 0-10 Vdc External Input Signal

This configuration is typically used for heating and make-up air units that require a mix of outside air and return air with the percentages being controlled by a Building Management System (BMS). The BMS would provide the control of the dampers through a 0-10Vdc external input signal.

GB = Fresh Air and Return Air Dampers with Modulating Damper Motor with 4-20 mA External Input Signal

This configuration is typically used for heating and make-up air units that require a mix of outside air and return air with the percentages being controlled by a Building Management System (BMS). The BMS would provide the control of the dampers through a 4-20 mA external input signal.

GC = Fresh Air and Return Air Dampers with Modulating Damper Motor with Minimum Positioner

This configuration is typically used for heating and make-up

air units that require a mix of outside air and return air with the percentage of outside air being the same at all times. Includes a factory mounted manual positioner in the blower section electrical cabinet that can be field set for the desired outside air percentage. When the unit is energized, the outside air damper would open to the preset percentage.

GD = Fresh Air and Return Air Dampers with Modulating Damper Motor with Remote Positioner

This configuration is typically used for heating and make-up air units that require a mix of outside air and return air with the percentage of outside air being changed throughout the day. The remote positioner is field mounted in the space so that the percentage of outside air can be manually changed from the space depending on the ventilation requirement. If a remote monitoring panel is ordered, the remote positioner can be mounted on the panel. When the unit is energized, the outside air damper would open to the preset percentage.

GE = Fresh Air and Return Air Dampers with Modulating Damper Motor for Three Positions

This configuration provides three positions (100% return air, a field adjustable percentage of outside and return air, and 100% outside air) of air control. It is typically used for heating and make-up air units that require 100% return air during the evening, a mix of outside air and return air during most of the daytime, and 100% outside air when an exhaust fan is operating. Includes a factory mounted manual positioner in the blower section electrical cabinet that can be field set for the desired outside and return air percentage. Also includes terminal strip contacts to provide 100% outside air when an exhaust fan contact (by others) is closed.

GF = Fresh Air and Return Air Dampers with Modulating Damper Motor with A350P Proportional Temperature Controller

This configuration is typically used for heating and make-up air units that require a mix of outside air and return air with the percentage of outside air being controlled by a proportional temperature controller. The proportional temperature controller monitors the temperature of the mixed fresh and return air and is usually set at 55°F to allow for first stage cooling. The proportional temperature controller will open the fresh air dampers and simultaneously close the return air dampers to maintain the preset mixed air temperature in the blower section of the unit. The fresh air dampers will modulate from zero to 100% open depending on the mixed air temperature. Includes a factory mounted A350P proportional temperature controller in the blower section electrical cabinet that can be field set for the desired outside air position with the sensing bulb factory mounted in the mixed air stream of the blower section.

GG = Fresh Air and Return Air Dampers with Modulating Damper Motor with Minimum Positioner and A350P Proportional Temperature Controller

This configuration is typically used for heating and make-up air units that require a mix of outside air and return air with the percentage of outside air being controlled by proportional temperature controller with a required percentage of outside air at all times. The minimum positioner sets the minimum percentage of outside air that will be provided at all times. The proportional temperature controller monitors the temperature of the mixed fresh and return air and is usually set at 55°F to allow for first stage cooling. The proportional temperature controller will open the fresh air dampers and simultaneously close the return air dampers to maintain the preset mixed air temperature in the blower section of the unit. The fresh air dampers will modulate from the minimum percentage (set by the minimum positioner) to 100% open depending on the mixed air temperature. Includes a factory mounted minimum positioner and A350P proportional temperature controller in the blower section electrical cabinet that can be field set for the desired outside air position with the sensing bulb factory mounted in the mixed air stream of the blower section.

GH = Fresh Air and Return Air Dampers with Modulating Damper Motor with Remote Positioner and A350P Proportional Temperature Controller

This configuration is typically used for heating and make-up air units that require a mix of outside air and return air with the percentage of outside air being controlled by proportional temperature controller with a required percentage of outside air at all times. The remote positioner (field mounted) sets the minimum percentage of outside air that will be provided at all times. The proportional temperature controller monitors the temperature of the mixed fresh and return air and is usually set at 55°F to allow for first stage cooling. The proportional temperature controller will open the fresh air dampers and simultaneously close the return air dampers to maintain the preset mixed air temperature in the blower section of the unit. The fresh air dampers will modulate from the minimum percentage (set by the remote positioner) to 100% open depending on the mixed air temperature. Includes a factory mounted A350P proportional temperature controller in the blower section electrical cabinet that can be field set for the desired outside air position with the sensing bulb factory mounted in the mixed air stream of the blower section. If a remote monitoring panel is ordered, the remote positioner can be mounted on the panel.

GJ = Fresh Air and Return Air Dampers with Modulating Damper Motor with Fresh Air Enthalpy Controller

This configuration is typically used for heating and make-up air units that require first stage ventilation in the summer. The load on the mechanical cooling system is reduced by mixing the percentage of outside air and return air based on the outside enthalpy, which is a combination of the temperature and humidity. As the enthalpy of the outside air decreases, the outdoor air damper opens to bring in more outside air to reduce the cooling load of the building. The enthalpy controller includes an adjustable minimum outside air positioner.

GK = ASHRAE Cycle II - Fresh Air and Return Air Dampers with Modulating Damper Motor with Minimum Positioner, A350P Proportional Temperature Controller, and Warm-Up Thermostat

Identical to Air Control GG with the addition of a factory installed warm-up thermostat. The warm-up thermostat is provided so that when the unit is switched into the daytime mode, the return air temperature is monitored and prevents the fresh air damper from opening until the temperature of the return air has reached the desired set point (usually 5°F below the room temperature).

GM = ASHRAE Cycle II - Fresh Air and Return Air Dampers with Modulating Damper Motor with Remote Positioner, A350P Proportional Temperature Controller, and Warm-Up Thermostat

Identical to Air Control GH with the addition of a factory installed warm-up thermostat. The warm-up thermostat is provided so that when the unit is switched into the daytime mode, the return air temperature is monitored and prevents the fresh air damper from opening until the temperature of the return air has reached the desired set point (usually 5°F below the room temperature).

GN = ASHRAE Cycle III - Fresh Air and Return Air Dampers with Modulating Damper Motor with A350P Proportional Temperature Controller, and Warm-Up Thermostat

Identical to Air Control GF with the addition of a factory installed warm-up thermostat. The warm-up thermostat is provided so that when the unit is switched into the daytime mode, the return air temperature is monitored and prevents the fresh air damper from opening until the temperature of the return air has reached the desired set point (usually 5°F below the room temperature).

HP = Fresh Air and Return Air Dampers with Floating Damper Motor with Space Pressure Controller

This configuration is typically used to maintain a slightly positive pressure in the building to reduce infiltration. It is also used to provide heating and make-up air for buildings that have multiple exhaust loads that cannot be interlocked to one make-up air unit. Includes a field installed photohelic pressure controller, relay, outside air pressure sensor, and 50 feet of 1/8" tubing to connect to the sensor. The photohelic pressure controller allows for easy adjustment of the high and low building pressure limits and includes an indicator showing the actual building pressure. The fresh air and return air dampers float to keep the building pressure between the desired limits. The limits are field adjustable between 0 and 0.25" W.C. When the unit is de-energized, a relay contact closes the outside air dampers.

JA = Manual Fresh Air and Return Air Dampers

This configuration is typically used for heating and make-up air units for which the damper position will never change. Includes a manual stop to hold the dampers open.

KA = Manual Fresh Air Dampers and Return Air Opening

This configuration is typically used for heating and make-up air units for which the damper position will never change. Includes a manual stop to hold the dampers open.

Digit 22

Evaporative Cooling (EC) (Outdoor Units)

The factory installed evaporative cooling option provides an economical means of supplying conditioned air to a space. Available in two media types and depths. For additional information on specification and selection, see pages 69-70.

- 0 = No Evaporative Cooler
- 3 = 6" Munsters® CELdek Media
- 4 = 12" Munsters® CELdek Media
- 5 = 6" Munsters® GLASdek Media
- 6 = 12" Munsters® GLASdek Media
- A - 6" CELdek Media, Stainless Steel Casing
- B - 12" CELdek Media, Stainless Steel Casing
- C - 6" GLASdek Media, Stainless Steel Casing
- D - 12" GLASdek Media, Stainless Steel Casing

Digit 23

Cooling Coil (CC)

For units with the cooling cabinet option (model sizes 75-400 only), this option indicates if the cooling coil is to be provided factory installed or by others. For determining the maximum size of the cooling coil and dimensions of the cabinet, see page 62.

- 0 = Coil By Others
- 1 = Factory Installed Coil

THIS PAGE INTENTIONALLY LEFT BLANK

Figure 24.1
Factory Mounted Option Locations

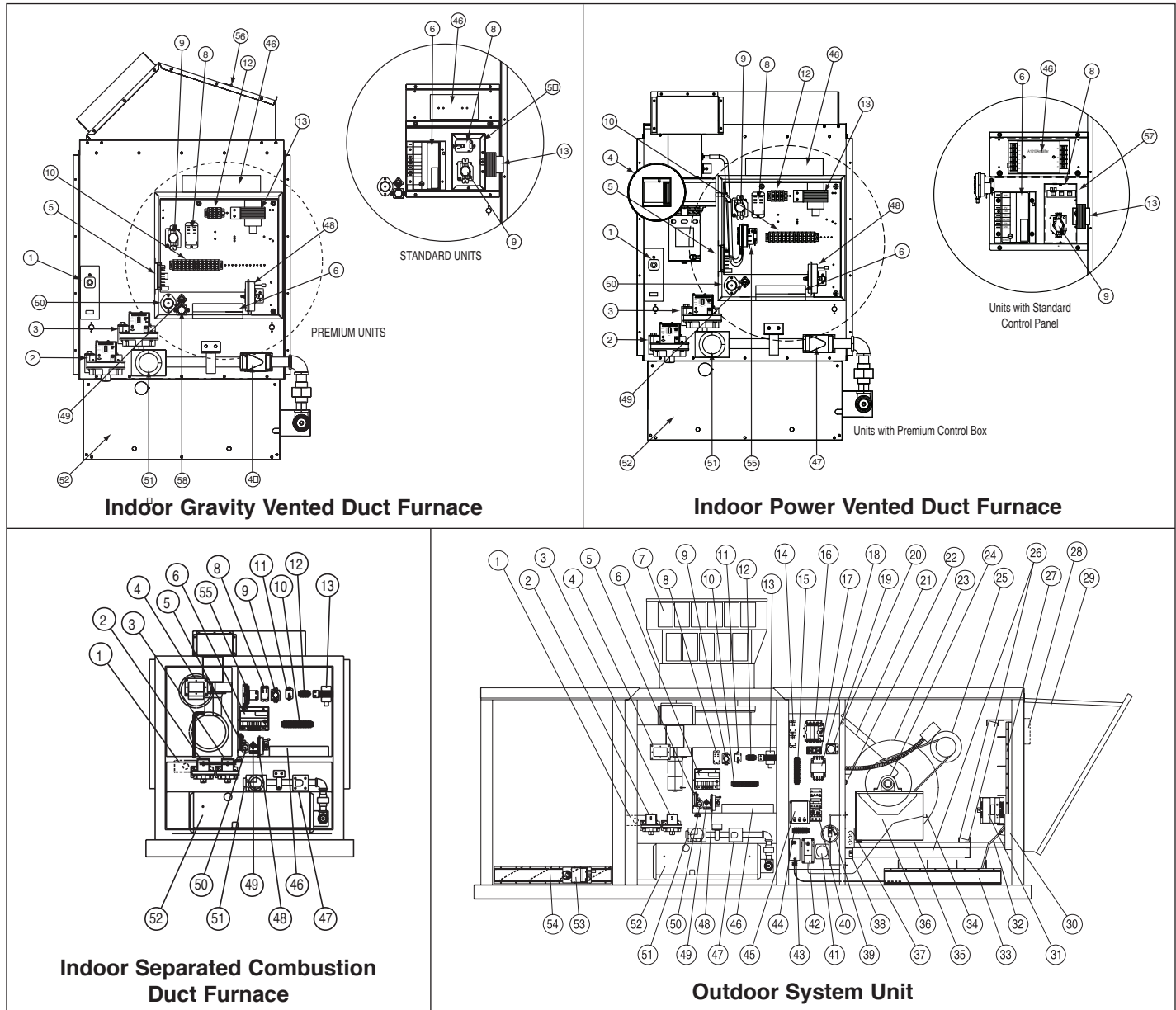

NOTE: Common blower cabinet for all above units.

- | | | |
|---|--|---|
| <ol style="list-style-type: none"> 1. Discharge Thermostat 2. Low Gas Pressure Switch 3. High Gas Pressure Switch 4. Power Exhauster 5. Timed Freeze Protection 6. Ignition Controller 7. Combustion Air/Exhaust Cap 8. Control Relay 9. Time Delay Relay 10. Furnace Low Voltage Terminal Strip 11. Power Exhauster Relay 12. Furnace Supply Power Terminal Strip 13. Control Step Down Transformer 14. Control Relay 15. Blower Low Voltage Terminal Strip 16. Dead Front Disconnect Switch 17. Step Down Transformer Fuses 18. Step Down Transformer 19. Factory Installed Minimum Positioner 20. Extended Grease Line Zerk Fittings | <ol style="list-style-type: none"> 21. Extended Grease Lines 22. Return Air Fire Stat 23. Blower Housing 24. Pillow Block Bearings 25. Blower Motor 26. Filters 27. Fresh Air Damper 28. Enthalpy Sensor (Outdoor only) 29. Rainhood and Birdscreen (Outdoor only) 30. Direct Drive Damper Actuator 31. Enthalpy Controller 32. Damper to Damper Linkage 33. Return Air Damper 34. Proportional Temp Controller Sensor 35. Motor and Blower Vibration Isolation 36. Blower Support 37. Convenience Outlet 38. Blower Door Switch 39. Dirty Filter Switch 40. Motor Starter/VFD control | <ol style="list-style-type: none"> 41. Mild Temperature Thermostat (Outdoor only) 42. Proportional Temp Controller 43. Warm-Up Stat 44. Blower Supply Power Terminal Strip 45. Service Switches 46. Electronic Modulating Amplifier 47. Electronic Modulating Gas Valve 48. Air Flow Proving Switch 49. High Limit Switch 50. Supply Air Fire Stat 51. Main Gas Valve 52. Burner Box 53. Direct Drive Damper Actuator (Outdoor only) 54. Discharge Damper (Outdoor only) 55. Differential Pressure Switch (Sep. Comb. only) 56. Blocked Vent Safety Switch 57. Control Terminal Board 58. Energy Cut off Switch |
|---|--|---|

The following list details the factory installed options available. For the location of all options, see Figure 24.1

Filters

All filters include an adjustable filter rack for 1" or 2" filters. Available filters are:

1" Permanent	2" Farr® Aeropleat (MERV 7)
2" Permanent	2" Farr® 30/30 (MERV 8)

Double Wall Construction

Includes a 22 gauge aluminized steel metal liner covering 1-1/2# density insulation (ordered separate for indoor units). The metal unit allows the interior of the unit to be wiped down for cleaning and conforms to ASHRAE Standard 62-2001 - Ventilation for Acceptable Indoor Air Quality. Available for Blower, Cooling and Downturn sections where applicable.

Motor and Blower Vibration Isolation (35)

Includes rubber-in-shear grommets to isolate the blower and motor assembly from the casing. The blower duct connection is not rigidly mechanically fastened and the 1/4" thick gasketing around the duct transition provides vibration isolation.

Air Flow Proving Switch (48)

The air flow proving switch is factory installed in the duct furnace electrical junction box. The air flow proving switch monitors the pressure differential between the duct furnace and the atmosphere. The purpose of the air flow proving switch is to cut power to the gas controls if a positive pressure is not measured by the switch. This could be caused by a lack of air movement through the heat exchanger.

Note: The air flow proving switch will prevent any heat exchanger warm-up because the gas controls cannot be energized until air flow is proven.

Timed Freeze Protection (5)

The timed freeze protection system is factory installed in the duct furnace electrical junction box with the sensor (30°-75°F adjustable) factory installed in the discharge air stream. On initial start-up, the timed delay in the system allows the unit to go through the normal ignition sequence. The timed delay is an automatic reset switch and adjustable for 1-10 minutes. In the event that the unit fails to fire after this period, the discharge air sensor will sense the cold air and will shut down the entire unit.

Mild Temperature Thermostat (41)

The mild temperature thermostat is factory installed in the blower electrical section for System Units and it senses outdoor air temperature. The purpose of the mild temperature thermostat (45°-75°F adjustable) is to cut power to the gas controls during mild weather so that the unit does not cycle in an attempt to maintain a very low air temperature rise. The mild temperature thermostat is usually set at approximately 60°F or 5°-10°F below the duct or room thermostat.

For Indoor units and Outdoor non-system units, the mild temperature thermostat (25°-225°F adjustable) is shipped loose for field installation in the inlet air stream.

For Outdoor 500-960 field installed mild temperature thermostats (either 25°-255°F or 0°-100°F adjustable) can be used to cut power to individual duct furnaces based on outside air temperature to reduce the amount of gas control cycling. One, two, or three mild temperature stats can be used based on the number of duct furnaces.

Supply Air Fire Stat (50)

The supply air fire stat is factory installed in the duct furnace electrical junction box with the sensor in the discharge air stream. In case of elevated temperatures (200°F) in the supply air, the manual reset switch shuts down the entire unit.

Return Air Fire Stat (22)

The return air fire stat is factory installed in the blower section electrical junction box with the sensor in the return air stream. In case of elevated temperatures (120°F) in the return air, the manual reset switch shuts down the entire unit.

Extended Grease Lines (21) (Requires Blower Pillow Block Bearings)

Includes factory installed grease lines extending from the blower bearings to the outside of the unit cabinet. Also includes zerk fittings for applying grease. Requires grease for initial start-up.

Control Relay (8)

Includes a 24v relay coil with double-pole, double throw (DPDT) contacts for sequence of operation control switching. The two normally open and two normally closed contacts are rated with a maximum of 30 amps @ 115V/1Ph. The relay is mounted in either the duct furnace junction box or the electrical section depending on the relay function.

Convenience Outlet (37)

Includes a factory installed 15 amp @ 115V ground fault circuit interrupter (GFCI) service receptacle in the blower section of the unit. Requires a separate field connected 115V/1Ph power supply.

Blower Door Safety Switch (38)

Includes a safety switch that breaks power in the unit low voltage control circuit when the blower door is opened.

Manual Reset High Limit Switch (49)

The manual reset high limit switch is factory installed in place of the standard automatic reset high limit switch located in the duct furnace electrical junction box. In case of a failure of the blower motor, blockage of the inlet air, etc., the manual reset switch prevents the unit from cycling on the high limit for a prolonged period of time. To prevent building freezing, this option is not recommended for heating units that are the only source of building heat.

Time Delay Relay (9) (Duct Furnace Units Only, Standard on System Units)

The time delay relay is factory installed in the duct furnace electrical junction box. The standard duct furnace is provided for instantaneous fan operation. On a call for heat, the blower is energized (control by others) at the same time as the gas controls. The optional time delay relay allows the gas controls to operate for approximately 30 seconds before the blower starts. This allows the heat exchanger a warm-up period so that the initial delivered air is not cool. The time delay relay also keeps the motor running for approximately 30 seconds after the call for heat has been satisfied to remove the residual heat from the heat exchanger.

2-Position Damper Limiter (Air Control EA and FA Only)

Mechanically prevents the outside air damper from opening completely and results in a fixed outside/return air percentage any time the dampers are energized. The outside air percentage must be specified when ordering and cannot be changed in the field.

Dirty Filter Pressure Switch (39)

Includes an adjustable differential pressure switch factory installed in the blower section. The switch monitors the filter pressure drop to determine if the filters are dirty. Required for remote monitoring panels with a dirty filter light.

Evaporative Cooling and Power Exhausted Step Down Transformers (18)

Evaporative cooling units which have a supply voltage of 208V/1Ph, 208V/3Ph, 460V/3Ph, or 575V/3Ph or power exhausted units that have 460V/3Ph, or 575V/3Ph require a step down transformer for the pump motor. Refer to electrical data for transformer sizing.

Discharge Air Damper (Downturn plenum outdoor units only) (54)

Used in 100% make-up air applications to prevent the building air from infiltrating back into the unit. Includes a factory installed discharge air damper and two-position damper motor located in the downturn plenum. The discharge damper is an ultra low leak, Class II leakage resistance (less than 10 CFM/ft² at 1" W.C.) damper with self-compensating stainless steel side seals and santoprene and galvanized steel blade seals. The damper motor includes end switches to prevent the blower from operating when the damper is not open.

Variable Frequency Drive (40)

The VFD controller adjusts the motor RPM to vary the unit airflow. The minimum air flow may be varied between 30 and 100% of the full speed airflow depending on the controls selection of the unit. The control changeover options are two speed, floating building pressure sensing, and building management control.

Circuit Analyzer (See Figure 26.1)

Used to quickly assist service personnel in trouble shooting. Monitors the unit firing sequence and vital operating steps. Lights will come on as a point of operation is passed and proven. If any light is not lit, that is the point where failure occurred. Circuit analyzer is mounted on the door of the blower section electrical compartment. There are 6 and 10 point analyzers available. Select circuit analyzer appropriate to the number of points to be monitored. The following points are available:

Point To Be Analyzed	Required Control Device
24V Transformer Power	None
Door Switch	Door Switch
Smoke Detector	Smoke Detector
Freeze Protection	Freeze Thermostat
Fire Stat	Fire Stat
Amplifier Power	Electronic Modulation Controls
Call For Heat	None
Air Flow Proving	Air Flow Proving Switch
Mild Temp Stat	Mild Temp Thermostat
Low Gas Pressure	Low Gas Pressure Switch
High Gas Pressure	High Gas Pressure Switch
High Limit	None
Burner On	None
Low Stage Heat	Two-Stage Controls
High Stage Heat	Two-Stage Controls
Warm Up Stat	Warm Up Thermostat
Dampers Open	Two Position Dampers
Mod Supply Air	Modulating Dampers
Dampers Opening	Floating Dampers
Dampers Closing	Floating Dampers
Blower On	None
Blower On (High)	Two-Speed VFD
Blower On (Low)	Two-Speed VFD
Evap On	Evaporative Cooler
Cool On	Control Relay (Cooling Circuit By Others)

Figure 26.1
Circuit Analyzer



Factory Installed Dead Front Disconnect Switches (See Figures 26.2 and 26.3)

Includes a disconnect switch that must be turned "OFF" before entry to the electrical control cabinet can be obtained. Switch can be manually overridden for purposes of servicing the unit. Factory installed in the door of the blower electrical compartment. Fusible and circuit breaker switches available. For fusible switches, includes blades and fuse holders (fuses not included). Provisions for Class "J" time delay fuses.

Field Installed Disconnect Switches

Includes a NEMA 3R disconnect switch to cut power to all electrical components of the unit before servicing. Non-fusible and fusible switches available. For fusible switches, includes blades and fuse holders (fuses not included). Provisions for Class "H" time delay fuses.

Figure 26.2
Electrical Section

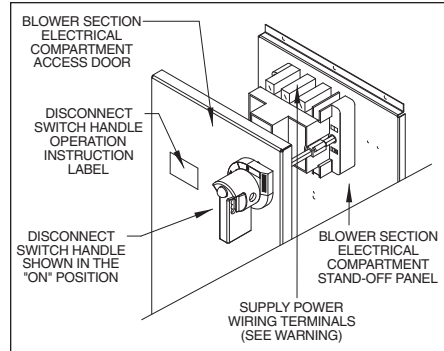

Figure 26.3
Electrical Section Wiring

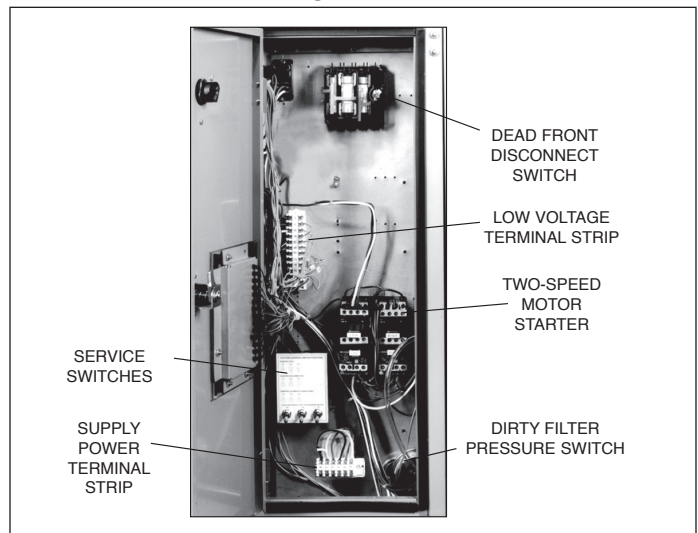
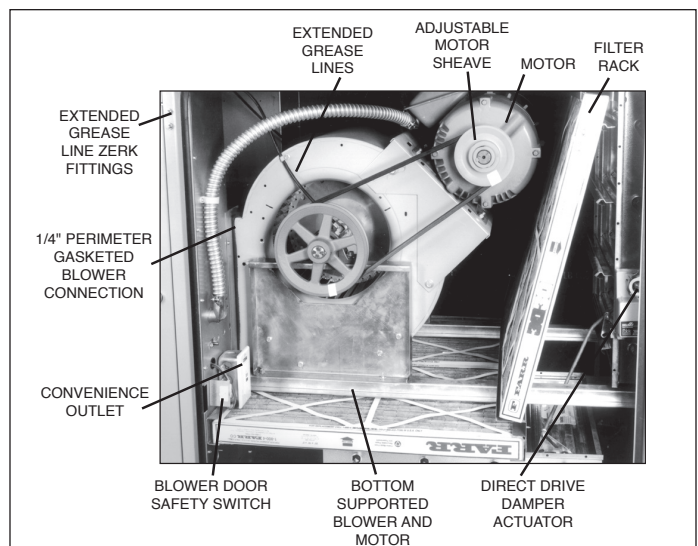

Figure 26.4
Blower Section

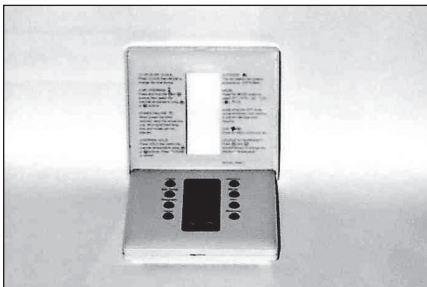

**Table 27.1
Factory and Field Installed**

	Type	Installation	Description
Single-stage Thermostats	Room	Field	White Rogers 1C20-101: 50°-90°F, 1.0A @ 24VAC
	Room	Field	White Rogers 1C26-101: 50°-90°F, 1.0A @ 24VAC, Heat/Off & Fan On/Auto switches
	Room - Programmable Figure 27.1	Field	Robertshaw 300-225 7-day programmable thermostat. One heat and one cool stage; Fan On/Auto and Heat/Off/Cool/Auto System Switching; 2 to 4 events per day; Override feature; One auxiliary output terminal.
Two-stage Thermostats	Room - Digital (With Switching)	Field	Honeywell TH5220D1029 digital non-programmable room stat with switching - range 40-90°F
	Room - Programmable Figure 27.1	Field	Robertshaw 300-229 7-day programmable thermostat. Two heat and two cool stages; Fan On/Auto and Heat/Off/Cool/Auto System Switching; 2 to 4 events per day; Override feature; One auxiliary output terminal.
	Duct ① ②	Factory or Field	Honeywell T678A1015 - 0-100°F temperature range; 20 foot capillary; 8 amp rating @ 120V.
	Duct Figure 27.3	Factory	Johnson Controls Electronic Temp Control with factory installed SET189A-600R Temp Sensor. Shipped loose A350 temp selector and one (up to two) S350 Stage Adder.
	Duct Figure 27.3	Field	Johnson Controls Electronic Temp Control with field installed SET189A-600R Temp Sensor, A350 temp selector and one (up to two) S350 Stage Adder.
Electronic Modulating Gas Control Thermostats	Duct Figure 27.4	Factory	Maxitrol Discharge Air Sensor TS121 and Mixing Tube MT2R-12. Range 55-90°F. REQUIRES THE ADDITION OF THE SET POINT ADJUSTER - Maxitrol TD121 (See below).
	Duct Figure 27.4	Field	Maxitrol Discharge Air Sensor TS121 and Mixing Tube MT1R-12. Range 55-90°F. REQUIRES THE ADDITION OF THE SET POINT ADJUSTER - Maxitrol TD121 (See below).
	Set Point Adjuster Figure 27.4	Field	Field Set Point Adjuster - Maxitrol TD 121 (For use with Maxitrol Duct Sensing System).
	Room Override Figure 27.4	Field	Can only be used with Maxitrol Duct Sensing System described above. Includes Maxitrol T115 room override stat. Temperature range 40-90°F.
	Room - Figure 27.2	Field	Maxitrol Selectra-Stat T120. Temperature range 60-85°F.

- ① For non-cooling indoor gravity and power vented units, the thermostat is factory installed with sensing tube shipped on the side of the unit for field installation.
- ② One or two duct stats can be used on Model Sizes 500-960 based on gas valve selection.

**Figure 27.1
7-Day Programmable Thermostat**



**Figure 27.2
Maxitrol Selectra-stat**



**Figure 27.3
System 350 Components**



**Figure 27.4
Maxitrol Duct Sensing Components**



Rainhood and Birdscreen (29)

(Outdoor only)

Used to prevent entry of rain into the fresh air opening of the unit. Fully assembled and constructed of 20 gauge polyester powder painted aluminized steel with internal baffles and a meshed bird screen. Not for use with units with evaporative coolers.

7-Day Electronic Programmable Time Clock

7-day/24-hour digital programmable time clock that features 7-day power-outage carryover of program and time of day without the use of batteries. The control allows for simple and inexpensive control of functions such as automatic temperature setback (requires setback thermostat purchased separately), reduction of outside air during periods when the building is not occupied, and switching main supply fans from continuous to intermittent operation.

As a 24-hour control, the same ON/OFF program is utilized each day of the week, Saturday and/or Sunday, or any other day may be skipped. When schedules vary from day to day, the 7-day programming capability allows for a different schedule each day of the week, with up to 16 set points available. Requires a 115V/1Ph power supply by others.

7-Day Econo-Timer

The 7 day push pin style appliance timer allows for simple and inexpensive control of functions such as automatic temperature setback (requires setback thermostat purchased separately), reduction of outside air during periods when the building is not occupied, and switching main supply fans from continuous to intermittent operation. The time clock shall be mounted in a suitable enclosure (by others) complying with the requirements of all local codes and the NEC. The terminals of the time clock are line voltage so the base must be located in a NEMA 1 enclosure (by others). Requires 115V/1Ph power supply by others.

Smoke Detector

Low profile duct style photoelectronic smoke detector designed to detect the presence of smoke in the duct. Once the smoke is sensed, the smoke detector will de-energize the unit. Must be installed indoors and duct velocity range must be between 500 to 4000 feet per minute. Double pole, double throw contacts, manual reset. For duct widths of up to 1-1/2 feet. For greater duct widths, smoke detector tube extensions are available for up to 8 foot wide ducts.

Gas Pressure Regulator

Fisher Type S-100, 3/4 inch pressure regulator for 5 to 10 PSI inlet pressure capacity, 30 MBH to 400 MBH. Natural or propane gas.

Thermostat Guards

Clear plastic for room thermostats. Guard is locking type and comes complete with two keys.

Summer/Winter Switch

Allows a choice of fan operation of the duct furnace/make-up air unit, the summer/winter toggle switch kit is available for field installation. In the summer position, the fan runs continuously for ventilation and the heating circuit is disabled. In the winter position for single-stage and two-stage gas control units, the thermostat will cycle the fan and the heating circuit. In the winter position for mechanical modulating and electronic modulating gas control units, the fan runs continuously for ventilation and the thermostat will cycle the heating circuit.

4' Extended Vent Kit (Outdoor only)

Gravity Vented Units

Includes the components required for the modification of the standard combustion air/vent cap to allow the vent cap to be extended approximately four feet above the unit. Includes the vent pipe, vent cap, and secondary restrictor.

Power Exhausted Units

Includes the components required for the modification of the standard vent discharge cover to allow the vent cap to be extended approximately four feet above the unit. Includes the vent pipe, vent cap, 90° elbow, exhaust collar, and strap clamp.

Remote Monitoring Panels

Used to control the operation of the make-up air unit. Standard remote panels include 2 lights (Heat On and Blower On) and a Summer/Off/Winter Switch. Custom remote panels are available, see page 59.

Roof Curbs (Outdoor only)

16" high roof curb is constructed of 16 gauge galvanized steel and designed to support the system units. The curb does not extend to the optional evaporative cooler section. The roof curb is shipped knocked down for field assembly and includes 1" x 4" nailer strips and curb gasket material. For flat roofs only and available insulated or uninsulated.

Discharge Air Connections and/or Return Air Connections (Outdoor only)

Used in conjunction with the roof curb, allows the discharge and/or return air ductwork connections to be made before the unit arrives at the job site.

“Heating Only” or “Heating and Recirculating” Operation

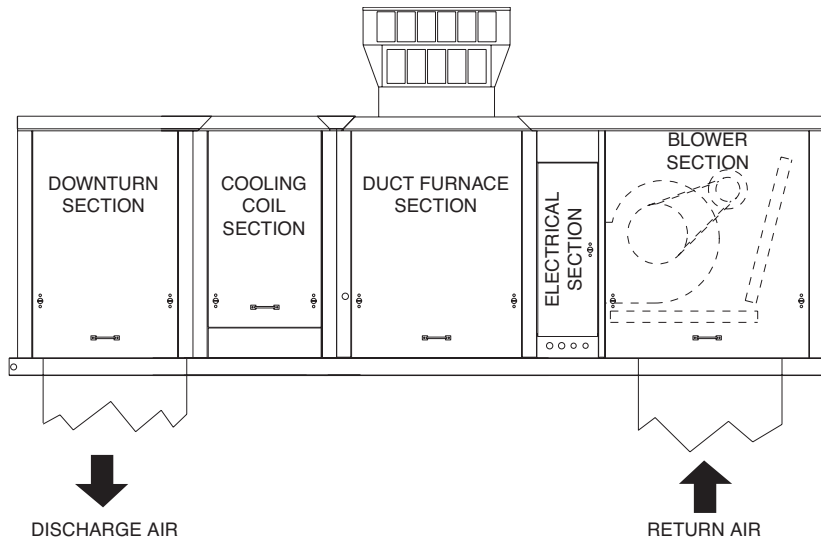

Method	Heating Control Device	Gas Valve (Digit 12)	Air Control (Digits 20 & 21)
A	Single-stage Room Thermostat	1-Single Stage	AA
B	Two-stage Room Thermostat	2-Two Stage	AA
C	Wall-mounted Selectra-stat	4, 7, or 8 - Electronic Modulating	AA

Various control application methods are illustrated on this page and on the following pages as guides to the types of systems available and the components necessary to obtain the desired control function. Under each application category, such as, “Heating Only”, several methods of operation are described. These methods are labeled as “A”, “B”, “C”, etc. The required components for a particular method of control are labeled in each diagram with the appropriate corresponding letter designation. As an example, under “Heating Only”, using method “A”, single-stage control, the required components would be: Single-Stage Heating Controls and a Single-Stage Room Thermostat. Method “B” would use the components labeled “B”. An operating description of each application method is given beneath the appropriate illustration.

Method A Single-stage heating of a space requires a single-stage control system with a single-stage room thermostat. The gas controls and blower motor are cycled each time the room thermostat calls for heat and the burner is fired at full rated input until the room temperature is satisfied. When the room thermostat is satisfied, both the burner and the blower motor are turned off.

Method B Two-stage heating of a space requires a two-stage control and a two-stage room thermostat. The first stage of burner fire and the blower motor are cycled by the first stage of the room thermostat on a call for heat. If the room thermostat cannot be satisfied by the low fire of the burner (50% firing rate) and the room temperature continues to fall, the second stage of the thermostat will activate the high fire or second stage of the burner. The burner will then fire at 100% of full rated input. When the second stage of the thermostat is satisfied, the burner is again fired at 50% of rated input until the first stage of the thermostat is satisfied. When both stages of the thermostat are satisfied, both the burner and blower motor will be shut off.

Method C Electronic modulating for space heating requires electronic modulating gas controls and a wall-mounted modulating thermostat. Upon a call for heat, the thermostat will energize the modulating regulator and fire the burner at 40% of full rated input. If the initial firing rate is not sufficient to satisfy the room temperature, the modulating thermostat will increase the rate of fire until the required room temperature is reached. If the room temperature should exceed the thermostat set point by as little as 1°F, the thermostat will shut off the burner and blower motor.

NOTE: The heating and recirculating operation can be achieved using the same components as shown for “Heating Only”. The only modification is that the blower motor is provided with constant power and runs continuously while the burner is cycled by the room thermostat whenever heat is required.

NOTE: Outdoor unit shown for demonstration purposes only. The above control application applies to all system units.

NOTE: Any of these sequences can include the cooling coil section. Also, the evaporative cooling option can be included on the units with outside air.

“Heating and Recirculating with Minimum Outside Air” Operation

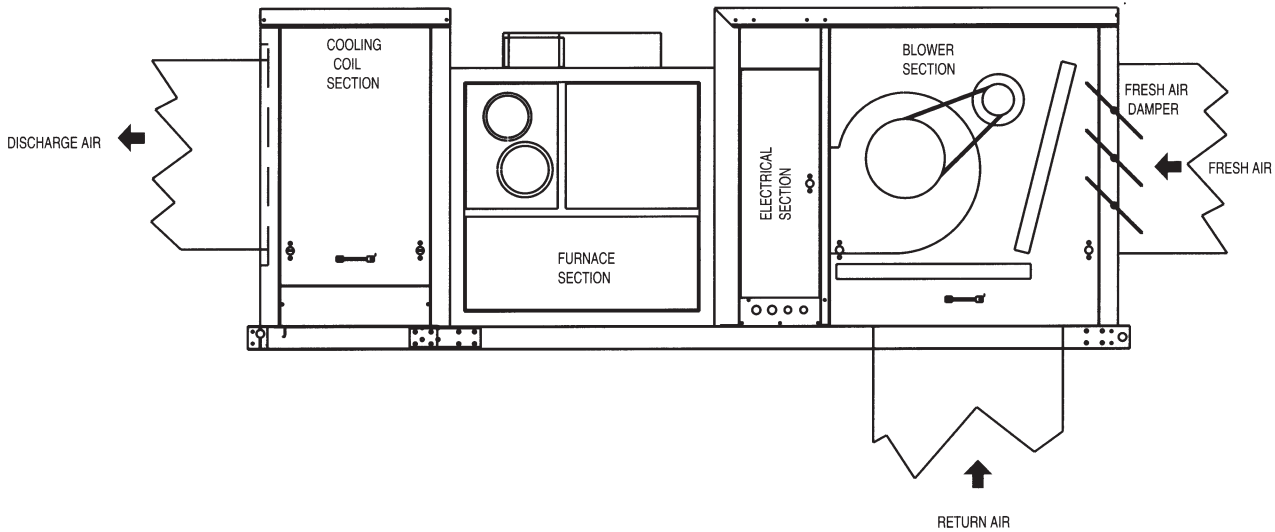

Method	Heating Control Device	Gas Valve (Digit 12)	Air Control (Digits 20 & 21) ①
A	Single-stage Room Thermostat	1-Single Stage	FA, GC, or GD
B	Two-stage Room Thermostat	2-Two Stage	FA, GC, or GD
C	Wall-mounted Selectra-stat	4, 7, or 8 - Electronic Modulating	FA, GC, or GD

Method A Single-stage heating and recirculating with minimum outside air requires: 1) a single-stage control system, 2) a single-stage room thermostat, and 3) a set of fresh air dampers with either a manual or automatic damper control. With this method, the blower motor is provided with constant power and runs continuously. The burner is cycled by the room thermostat each time the thermostat calls for heat. Either a two-position or modulating damper can be used with this system.

Method B Two-stage heating and recirculating with minimum outside air requires: 1) a two-stage control system, 2) a two-stage room thermostat, and; 3) a set of fresh air dampers with either manual or automatic damper control. With this method, the blower is provided with constant power and runs continuously. The burner is controlled by the two-stage thermostat and fires at either 50% or 100% of full-rated input. Upon a call for heat from the first stage of the room thermostat, the burner is fired at 50% of rated input. If the room temperature continues to fall and the set point of the second stage of the thermostat is reached, the second stage of the burner is energized and the burner fires at 100% of full-rated input. As the room

temperature is satisfied, the burner first returns to 50% fire and, if the temperature reaches the set point of the first stage of the room thermostat, the burner is turned off. Either a two-position or modulating damper motor can be used with this system.

Method C Electronic modulation and air recirculation with minimum outside air requires: 1) an electronic modulating control system, 2) a modulating room thermostat, and 3) a set of fresh air dampers with manual or automatic control. With this method, the blower is provided with constant power and runs continuously. The burner is controlled by the modulating room thermostat. Upon a call for heat, the thermostat will energize the gas modulating regulator and fire the burner at 40% of full rated input. If the initial firing rate is not sufficient to maintain the desired room temperature, the modulating thermostat will increase the rate of burner fire until the thermostat set point is reached. If the room temperature should exceed the thermostat setting by as little as 1°F, the thermostat will shut off the burner. Either a two-position or modulating damper motor can be used with this system.

① If Air Control FA is used with the 2-position Damper Limiter option, the damper stroke is limited to the desired minimum outside air position at the factory and cannot be changed. Power is supplied to the damper motor anytime the system is in operation. The damper motor drives the fresh air damper open to the predetermined minimum position. If power is interrupted, the dampers will return to the closed position.

If Air Control GC or GD is used, then the minimum positioner is used to operate the damper motor. With the positioner it is possible to set the dampers to any desired minimum outside air open position. This position can be changed at any time by adjusting the positioner to another setting.

NOTE: Separated combustion unit shown for demonstration purposes only. The above control application applies to all system units.

NOTE: Any of these sequences can include the cooling coil section.

“Heating and Recirculating with Minimum Outside Air and Mixed Air Temperature Control” Operation

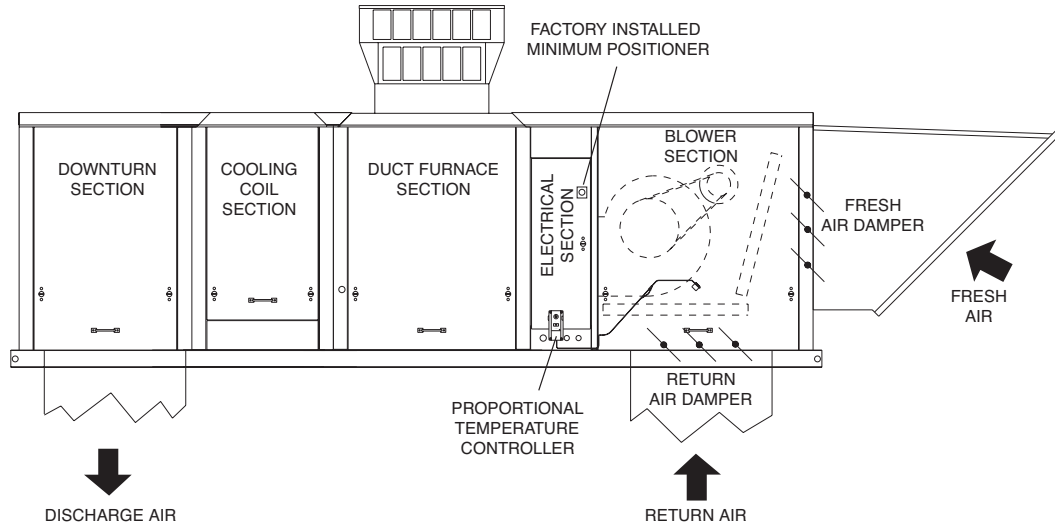

Method	Heating Control Device	Gas Valve (Digit 12)	Air Control (Digits 20 & 21)
A	Single-stage Room Thermostat	1-Single Stage	GG or GH
B	Two-stage Room Thermostat	2-Two Stage	GG or GH
C	Wall-mounted Selectra-stat	4, 7, or 8 - Electronic Modulating	GG or GH

Method A Single-stage heating and recirculating with minimum outside air and mixed air temperature requires: 1) a single-stage control system, 2) a single-stage room thermostat, 3) a minimum positioner for minimum outside air setting of dampers, 4) fresh and return air modulating dampers, and, 5) a mixed air temperature controller. With this method the blower motor is provided with constant power and the blower runs continuously. The burner is cycled by the room thermostat each time the thermostat calls for heat. The minimum positioner is used to set the minimum outside air damper position and can be adjusted to provide different levels of minimum outside air depending upon the requirements of the space being heated. The proportional temperature controller, located in the blower section of the outdoor make-up air unit, senses the mixed temperature of the fresh and return air and modulates the fresh and return air dampers to maintain a preset mixed air temperature.

Method B Two-stage heating and recirculating with minimum outside air and mixed air temperature control requires: 1) a two-stage control system, 2) a two-stage room thermostat, 3) a minimum positioner for minimum outside air setting of dampers, 4) fresh and return air modulating dampers, and, 5) a mixed air temperature controller. With this method, the blower is provided with constant power and runs continuously. The burner is controlled by the two-stage room thermostat and fires the burner at either 50% or 100% of full-rated input. On a call for heat from the first stage of the thermostat, the burner is fired at 50% of rated input. If the room temperature continues to fall and the set point of the second stage of the thermostat is reached, the second stage of the burner is energized and the burner fires at 100% of full-rated input. As the room temperature is satisfied, the burner first returns to 50%

fire and, as the temperature reaches the set point of the first stage of the room thermostat, the burner is turned off. The minimum positioner can be adjusted to provide different levels of minimum outside air depending upon the requirements of the space being heated. The proportional temperature controllers, located in the blower section of the outdoor make-up air unit, senses the mixed temperature of the fresh and return air and modulates the fresh and return air dampers to maintain a preset mixed air temperature.

Method C Electronic modulation and air recirculation with minimum outside air and mixed air temperature control requires: 1) an electronic modulating control system, 2) a modulating room thermostat, 3) a minimum positioner for minimum outside air settings of dampers, 4) fresh and return air modulating dampers, and, 5) a mixed air temperature controller. With this method, the blower is provided with constant power and runs continuously. The burner is controlled by the modulating room thermostat. Upon a call for heat, the thermostat will energize the gas modulating regulator and fire the burner at 40% of full rated input. If the initial firing rate is not sufficient to maintain the desired room temperature, the modulating thermostat will increase the rate of burner fire until the thermostat set point is reached. If the room temperature should exceed the thermostat setting by as little as 1°F, the thermostat will shut off the burner. The minimum positioner can be adjusted to provide different levels of minimum outside air depending on the requirements of the space being heated. The proportional temperature controller located in the blower section of the outdoor make-up air unit, senses the mixed temperature of the fresh and return air and modulates the fresh and return air dampers to maintain a preset mixed air temperature.

NOTE: Outdoor unit shown for demonstration purposes only. The above control application applies to all system units.

NOTE: Any of these sequences can include the cooling coil section. Also, the evaporative cooling option can be included on the units with outside air.

“Heating and Recirculating with Space Pressure Sensing Control” Operation

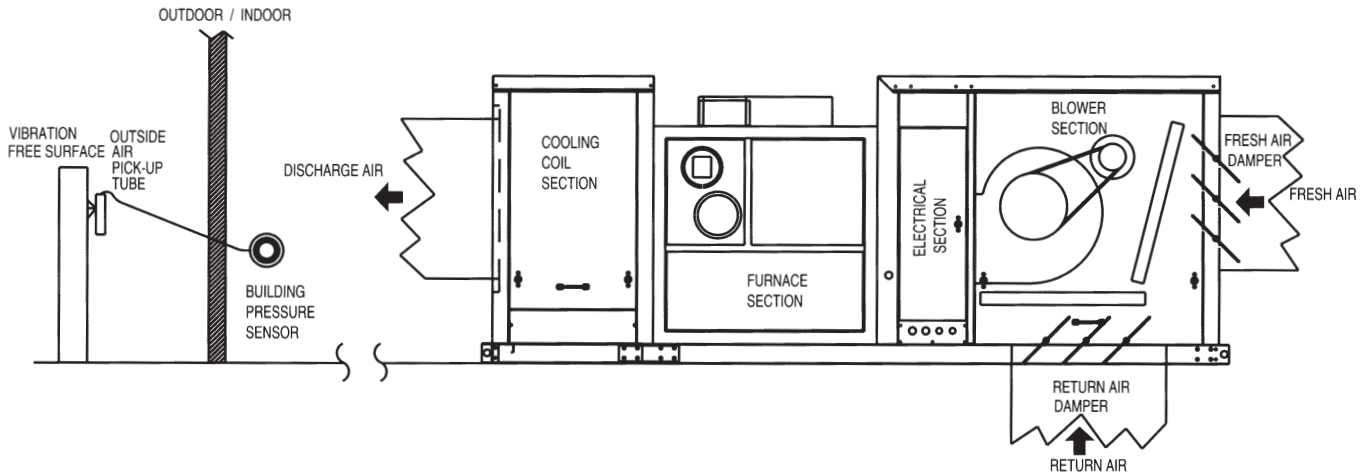

Method	Heating Control Device	Gas Valve (Digit 12)	Air Control (Digits 20 & 21)
A	Two-stage Duct & Two-stage Room Stat	2-Two Stage	HP
B	Maxitrol Duct Sensing System with Room Override	4, 7, or 8 - Electronic Modulating	HP

Method A Two stage heating and recirculating with space pressure sensing requires: 1) a two stage control system, 2) a two stage duct thermostat, 3) two stage room thermostat, 4) fresh and return air dampers, 5) a floating damper actuator, and 6) a space pressure sensor with outside air pick-up tube. With this method the blower motor is provided with constant power and the blower runs continuously. The burner is controlled by either the two stage duct thermostat or the two stage room thermostat and fires the burner at either 50% or 100% of the full rated input. The duct thermostat fires the burner to maintain the desired discharge air temperature and the room thermostat fires the burner to maintain the desired room temperature. On a call for heat from the first stage of either thermostat, the burner is fired at 50% of the rated input. If the discharge or room temperature continues to fall and the set point of the second stage of the thermostat is reached, the second stage of the burner is energized and the burner fires at 100% of the full rated input. As the discharge or room temperature is satisfied, the burner first returns to 50% fire and as the temperature reaches the set point of the first stage of the thermostat, the burner is turned off. The space pressure sensor controls the damper position by measuring the differential between the outside air pressure and the space pressure. The space pressure can be adjusted to keep a positive space pressure between 0 and 0.25" W.C. When the space pressure is above the desired set point, the fresh air damper starts to close and the return air damper opens to bring in less outside air since the space pressure is getting too high. When the space pressure is below the desired set point, the fresh air damper opens to bring in more outside air. When the unit is shut off, the fresh air damper is driven closed.

Method B Electronic modulation heating and recirculating with space pressure sensing requires: 1) an electronic modulating control system, 2) a modulating duct thermostat, 3) a room override thermostat, 4) fresh and return air dampers, 5) a floating damper actuator, and 6) a space pressure sensor with outside air pick-up tube. With this method the blower motor is provided with constant power and the blower runs continuously. The burner is controlled by either the modulating duct thermostat or the single stage room override thermostat. The duct thermostat fires the burner to maintain the desired discharge air temperature and the room override thermostat fires the burner to maintain the desired room temperature. On a call for heat from the duct thermostat, the duct thermostat will energize the gas controls and fire the burner at 40% of the full rated input. If the initial firing rate is not sufficient to maintain the desired discharge temperature, the modulating thermostat will increase the rate of burner fire until the thermostat set point is reached. If the discharge temperature should exceed the duct thermostat setting by as little as 1°F, the thermostat will shut off the burner. On a call for heat from the room override thermostat, the room override thermostat provides full fire operation until the room temperature is satisfied. The space pressure sensor controls the damper position by measuring the differential between the outside air pressure and the space pressure. The space pressure can be adjusted to keep a positive space pressure between 0 and 0.25" W.C. When the space pressure is above the desired set point, the fresh air damper starts to close and the return air damper opens to bring in less outside air since the space pressure is getting too high. When the space pressure is below the desired set point, the fresh air damper opens to bring in more outside air. When the unit is shut off, the fresh air damper is driven closed.

NOTE: Separated Combustion unit shown for demonstration purposes only. The above control application applies to all system units.

NOTE: Any of these sequences can include the cooling coil section.

“100% Make-up Air” Operation

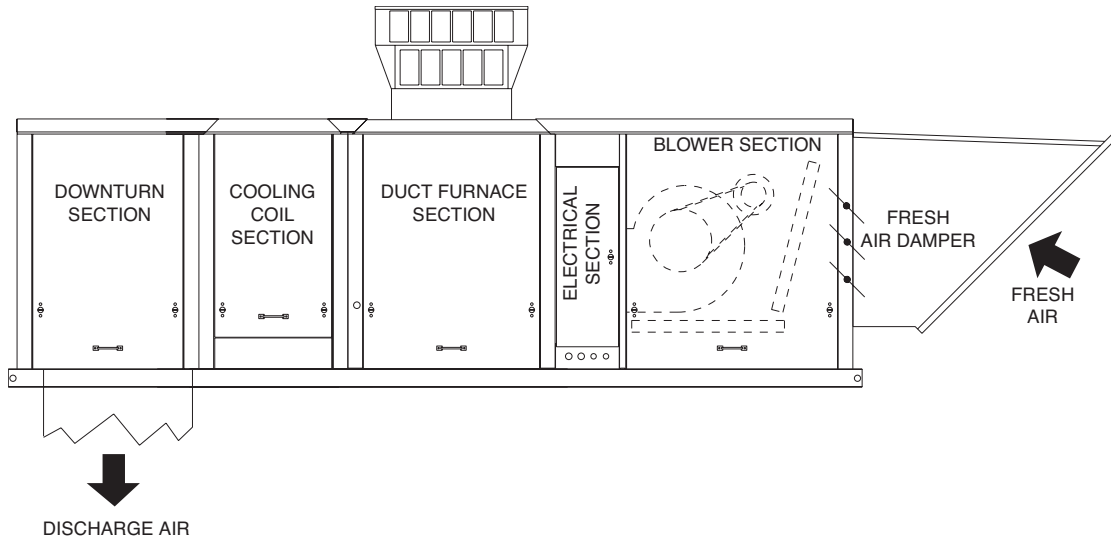

Method	Heating Control Device	Gas Valve (Digit 12)	Air Control (Digits 20 & 21)
A	Two-stage Duct Thermostat	2-Two Stage	DA
B	Maxitrol Duct Sensing System	4, 7, or 8 - Electronic Modulating	DA

Method A Two-stage make-up air systems require: 1) a two-stage control system, 2) a two-stage duct stat, and 3) a set of fresh air dampers. With this method of make-up air, the blower motor is provided with constant power anytime the system is on and the blower runs continuously. The burner is controlled by a two-stage duct stat which senses discharge air from the unit. The burner is fired at 50% and 100% of full-rated input, depending on the demand from the two-stage duct stat. The first stage of fire is at 50% of rated input. If this is not sufficient to maintain the desired discharge temperature, the second stage of the burner is energized by the second stage of the duct stat to achieve 100% fire. The fresh air damper is of the two-position type, either open or closed. It is always open whenever power is supplied to the make-up air unit. If power is interrupted, the damper will return to the closed position.

Method B Electronic modulating make-up air systems require 1) an electronic modulating control system, 2) a duct sensing system, and 3) a set of fresh air dampers. With this system, the sensing probe of the duct sensing system is placed in the discharge air stream to sense the discharge air temperature. If the discharge air temperature is lower than the duct sensing system setpoint adjuster, the sensing probe will send a signal to the modulating valve and low fire will begin. Low fire is 40% of full-rated input. If this firing rate is not sufficient to achieve the desired temperature, the valve will continue to open and allow firing rates between 40% and 100% of full-rated input until the discharge air temperature is satisfied. The fresh air damper is of the two-position type, either open or closed. It is always open whenever power is supplied to the make-up air unit. If power is interrupted, the damper will return to the closed position. The blower also runs continuously as long as power is supplied to the make-up air unit. This system can be used with an override thermostat.

NOTE: Outdoor unit shown for demonstration purposes only. The above control application applies to all system units.

NOTE: Any of these sequences can include the cooling coil section. Also, the evaporative cooling option can be included on the units with outside air.

Selection Procedure

In order to properly select an indirect-fired heating, ventilating, cooling or make-up air unit, it is necessary to have the following basic information.

- 1. Required air handling capacity (CFM).**
The air capacity of the unit is usually determined by the ventilation air requirements, exhaust load of the building, infiltration losses, or the air turns/changes of the space.
- 2. Outdoor and indoor design temperature.**
The outdoor design temperature is determined by using the ASHRAE Guide design temperatures for the city where the equipment is to be installed. For heating and ventilating units, the desired room temperature would be used as the indoor design temperature. In the case of 100% make-up air units, the discharge air temperature should be at least equal to the temperature of the air being exhausted.
- 3. Required heating output capacity (Btu/Hr).**
The heating output capacity of the unit is determined by using the formula:
$$\text{BTU/HR} = \text{CFM} \times \text{Temp. Rise (}^\circ\text{F)} \times 1.08$$
- 4. External static pressure to unit.**
The external static pressure (E.S.P.) is determined using the ASHRAE Guide for duct losses, or may be provided by the design engineer.
- 5. Unit configuration with options and accessories (Rainhood, filters, dampers, or evaporative cooler).**
The unit configuration is determined by the location where the unit is to be installed. The critical options and accessories are those that add internal static pressure (I.S.P.) to the unit. Once these items are determined, the pressure drop curves would be used to calculate the total pressure drop (T.S.P.).
$$\text{Total Static Pressure} = \text{Internal} + \text{External Static Pressure}$$
- 6. Heat exchanger material.**
The heat exchanger type is determined by the application. The standard heat exchanger material is aluminized steel. A 409 stainless steel heat exchanger and burner is recommended when the unit is installed downstream of a cooling coil or evaporative cooler, or when the combined entering/return air to the unit is below 40°F.
- 7. Type of fuel.**
Either natural or propane gas determined by the design engineer.
- 8. Gas control staging method.**
Either single stage, two stage or electronic modulation determined by the design engineer.
- 9. Main power supply voltage to unit.**
- 10. Altitude at which unit is to be installed.**

With this information a basic unit can be selected as shown in the following example.

Selection Example Conditions

In the following example, an outdoor unit is used for demonstration purposes. Use same procedure for all indoor units.

Select an indirect-fired, 100% make-up air unit to meet the following conditions:

1. CFM at sea level = 5,000 CFM
2. Outdoor design temp. = 10°F
Indoor design temp. = 70°F
3. Heating output capacity =
 $5000 \text{ CFM} \times (70^\circ\text{F} - 10^\circ\text{F}) \times 1.08 = 324,000 \text{ Btu/Hr}$
4. External Static Pressure = 0.65" WC
5. The Gravity Vented unit with the controls on the Right Hand Side is to be provided with the following:
2" Permanent Filters, a Rainhood with Fresh Air Damper, and a Downturn
6. Heat exchanger and burner = 409 Stainless Steel
7. Gas Type = Natural
8. Gas Controls = Electronic Modulating with Duct Sensing
9. Supply Voltage: 460V/60Hz/3Ph
10. Altitude: 1000 feet

With the information listed above, the basic model, using the Model Nomenclature shown on page 75, can be selected as shown in the following example:

- 1. Determine the Model Configuration and Venting:**
The Model Configuration is determined by the required sections of the unit (Blower and Downturn) and the venting style (Gravity) that are obtained from item #5. Using the Model Nomenclature on page 75 the Model Configuration and Venting = HDG.
- 2. Determine the Furnace Input Rating (MBH):**
Using the Heating output capacity, the Furnace Input Rating is determined from Table 17.1. The closest model to 324,000 Btu/Hr output has an Btu/Hr Input rating of 400,000 Btu/Hr so the Furnace Input Rating = 400.
- 3. Determine the Heat Exchanger/Burner/Drip Pan Material:**
From item #2 listed above, the Heat Exchanger and Burner required are 409 Stainless Steel. Because the Drip Pan material is not specified, the standard Aluminized Steel drip pan will be used. Thus, the Heat Exchanger/Burner/Drip Pan Material = S.
- 4. Determine the Development Sequence:**
From item #8 listed above, the modulating gas controls result in the Development Sequence = M.
- 5. Determine the Access Side:**
From item #5 listed above, the Right Hand Gas controls result in the Access Side = R.
- 6. Determine the Air Temperature Rise:**
From item #2 listed above, the Air Temperature Rise is 60°F (70°F - 10°F). However, using the output capacity of the HDG400 @ 5000 CFM, the resulting temperature rise is 59.3°F (320,000 / (5000 x 1.08)). Since the rise is less than 60°F, the Air Temperature Rise = L.
- 7. Determine the Gas Type:**
From item #7 listed above, the Natural Gas results in the Gas Type = N.
- 8. Determine the Gas Valve:**
From item #8 listed above, the Electronic Modulating with Duct Sensing results in the Gas Valve = 4.
- 9. Determine the Additional Safety Switches:**
Since no additional safety switches were specified, the Additional Safety Switches = 0.

10. Determine the Supply Voltage:

From item #9 listed above, the 460V/60Hz/3Ph results in the Supply Voltage = F.

11. Determine the Transformer:

Using Table 19.1 with the selected Unit Type = HDG, the Transformer = 2.

12. Determine the Blower Size and Bearing Type:

Using Table 16.1, the Model Size 400 has three available blowers for which the performance tables are shown on pages 36-38. Since all of the blower performance tables can provide the required 5000 CFM, the total static pressure for each blower performance curve must be determined.

A) The Pressure Drop of an option or accessory is determined by entering the right of the table at the desired CFM and reading across the table until the CFM intersects the desired item. For this example, in table 36.1 the 2" Permanent Filter is used. At the point of intersection, read across the table to the right and read the pressure drop, in inches of water column for the filters. For this example, the pressure drop is 0.06" W.C. This method is used to determine the pressure drop for the other options and accessories. As a result:

For the Model Size 400 with Digit 16 = E,F,G, or H:	
2" Permanent Filters:	0.06" W.C.
Rainhood:	0.11" W.C.
Downturn:	0.07" W.C.
Internal Static Pressure Drops	0.24" W.C.

The Total Static Pressure for the system is determined by Internal Static + External Static = Total Static Pressure
For this example 0.24" + 0.65" = 0.89" W.C. T.S.P.

From page 36, for the Model Size 400 with Digit 16 = I, J, or K:	
2" Permanent Filters:	0.04" W.C.
Rainhood:	0.11" W.C.
Downturn:	0.07" W.C.
Internal Static Pressure Drops	0.22" W.C.

The Total Static Pressure for the system is determined by Internal Static + External Static = Total Static Pressure
For this example 0.22" + 0.65" = 0.87" W.C. T.S.P.

B) Using the total static pressure (T.S.P.) calculated in step 12a, use blower performance tables for the Model Size 400 (Table 38.1).

Using Table 38.1, enter the table at the required 5000 CFM for E.F. blowers, and follow the CFM line to the right until it intersects with the T.S.P. line of 0.75" W.C. which is shown at the top of the table. At the point of intersection of these two columns, read the required horsepower and blower RPM. Repeat this process for 1.00" T.S.P and iterate to determine the BHP and RPM for 0.89" W.C. For this example the horsepower is 5 and the blower RPM is 1280.

Following this procedure for G,H blowers (Using 5000 CFM and 0.89" W.C. T.S.P), the horsepower is 5 hp and 920 RPM. Following this procedure for I,J,H blowers (Using 5000 CFM and 0.87" W.C. T.S.P), the horsepower is 3 hp and 700 RPM. Although I,J,H blowers results in a 3 hp motor, this blower requires the use of the extended cabinet length. As a result, for purposes of this selection example G,H blowers will be used.

Since the Bearing Type was not specified, the standard spider bearings will be used. Thus, using Table 38.1 with spider bearings, the Blower Size and Bearing Type = G.

13. Determine the Motor Horsepower:

The motor horsepower determined in step 12 was a 3 Hp. Since the supply voltage is 460V/60Hz/3Ph, a motor starter will need to be provided either with the unit or by others. For purposes of this selection, a motor starter by others will be used so the Motor Horsepower = G.

14. Determine the Motor Type:

The motor type was not specified so for purposes of this selection the standard open drip proof motor will be used so the Motor Type = 1.

15. Determine the Sheave Arrangement:

To establish the Sheave Arrangement, the motor frame size must be determined. The Motor Data tables on pages 42 to 44 contain the motor frame size.

A) Using the Supply Voltage (460V/60Hz/3Ph), enter the correct Motor Data table (Table 44.1). Using Model Nomenclature Digits 17 and 18 (G1) determined in steps 13 and 14, find the motor frame size (182T).

B) Using the Motor Frame Size enter the Sheave Selection table for the selected blower determined by step 13 (Table 40.4). Using the RPM calculated in step 12 (920 RPM), select the sheave range that contains the required RPM. Find the intersection with the Motor Frame Size to determine the Sheave Selection. For this example with a 182T frame with 920 RPM, from Table 40.4, the Sheave Arrangement = I.

16. Determine the Air Control:

The Air Control option is selected based on the required damper configuration. The available damper selections are detailed on pages 20 through 22. For this selection, a 100% fresh air unit without return air was required so the Air Control = DA.

17. Determine the Evaporative Cooler:

An evaporative cooler was not specified so for purposes of this selection the Evaporative Cooler = 0.

18. Determine the Cooling Coil:

A cooling coil cabinet was not specified so for purposes of this selection the Cooling Coil = 0.

Based on the previous steps, the model number for the base unit is the following:

HDG400SMRLN40F2GG1IDA00

Once the basic model has been determined, the additional options and accessories outlined on page 24 to 28 can be added to the unit.

IMPORTANT

When selecting the required motor horsepower, the horsepower must always be read off the curve to the right of the data point determined from the intersection point of the cfm and T.S.P. lines.

Table 40.1 - Digit 19 – Sheave Arrangement for Digit 16 = A or B (9-7 Blower Units)

Motor Frame Size	RPM Range				
	656-1001	978-1265	1150-1561	1526-1858	1763-2147
48	A	C			
56	B	D	F	H	J
143 or 145		E	G	I	K

Table 40.2 - Digit 19 – Sheave Arrangement for Digit 16 = C or D (9-9 Blower Units)

Motor Frame Size	RPM Range				
	656-1001	978-1265	1150-1561	1526-1858	1763-2147
48	A	C			
56	B	D	F	I	L
143 or 145		E	G	J	M
182 or 184			H	K	N

Table 40.3 - Digit 19 – Sheave Arrangement for Digit 16 = E or F (12-12 Blower Units)

Motor Frame Size	RPM Range					
	468-715	644-874	863-1078	1029-1332	1150-1438	1327-1659
48	A					
56	B	C	F	Q		
143 or 145		D	G	I	L	
182 or 184		E	H	J	M	O
213 or 215				K	N	P

Table 40.4 - Digit 19 – Sheave Arrangement for Digit 16 = G or H (15-15 Blower Units)

Motor Frame Size	RPM Range				
	410-625	568-771	767-958	934-1136	1136-1380
48	A				
56	B	D	G	O	
143 or 145	C	E	H	J	
182 or 184		F	I	K	M
213 or 215				L	N

Table 40.5 - Digit 19 – Sheave Arrangement for Digit 16 = I or J (18-18 Blower Units under 15 Hp motor)

Motor Frame Size	RPM Range					
	491-624	586-744	682-821	821-1009	995-1161	1101-1285
56	A	D				
143 or 145	B	E	H			
182 or 184	C	F	I	K	O	
213 or 215		G	J	L	P	S
254				M	Q	T
256				N	R	U

Table 40.6 - Digit 19 – Sheave Arrangement for Digit 16 = K (18-18 Blower Units with 15 Hp motor & up)

Motor Frame Size	RPM Range			
	826-1009	995-1161	1101-1285	1232-1438
254	A	C	E	
256	B	D	F	
284	G	I	K	M
286	H	J	L	N

Table 40.7 - Digit 19 – Sheave Arrangement for Digit 16 = L (20-18 Blower Units)

Motor Frame Size	RPM Range					
	491-649	626-765	765-901	901-1059	995-1161	1101-1285
143 or 145	A	C				
182 or 184	B	D	F	L		
213 or 215		E	G	M	R	
254			H	N	S	W
256			I	O	T	X
284			J	P	U	Y
286			K	Q	V	Z

Total Unit Amp Draw

The total unit amp draw is a combination of the motor, the control step down transformer, the power exhaustor motor, and the evaporative cooler pump motor (or step down transformer for 208V/1Ph, 208V/3Ph, 460V/3Ph, or 575V/3Ph units) where applicable. The control step down transformer includes damper actuators, ignition controllers, gas valves, control relays, amplifiers, and motor starters.

$$\begin{aligned}
 &\text{Motor Amp Draw (Tables 42.1 to 44.2)} &&= \\
 &\text{Control Step Down Transformer Amp Draw (Table 41.1)} &&= \\
 &\text{Power Exhauster Motor Amp Draw (Table 41.1)} &&= \\
 &\text{Evaporative Cooler Amp Draw (Table 41.2)} &&= \\
 &&&+ \text{_____} \\
 &\text{Total Amp Draw} &&=
 \end{aligned}$$

Table 41.1
Control Step Down Transformer and Power Exhauster Amp Draws

Digit 14		Control Step Down Transformer Amp Draw					Power Exhauster Amp Draw ①			
Supply Voltage		Digit 15 - Transformer					Model Size			
		0	1	2	3	4	75-175	200-400	500-800	840-960
A	115/60/1	0	0.35	0.65	1.3	2.17	1.4	2.00/2.40	4.00/4.80	6.00/7.20
B	208/60/1	0	0.19	0.36	0.72	1.2	0.7	1.10/1.40	2.20/2.80	3.30/4.20
C	230/60/1	0	0.17	0.33	0.65	1.09	0.66/0.60	0.95/1.30	1.90/2.60	2.85/3.90
D	208/60/3	0	0.19	0.36	0.72	1.2	0.7	1.10/1.40	2.20/2.80	3.30/4.20
E	230/60/3	0	0.17	0.33	0.65	1.09	0.66/0.60	0.95/1.3	1.90/2.60	2.85/3.90
F	460/60/3 ⑥	0	0.09	0.16	0.33	0.54	0.54②	0.54②/1.08③	1.08③/1.63④	1.63④/2.17⑤
G	575/60/3 ⑥	0	0.07	0.13	0.26	0.43	0.43②	0.43②/0.87③	0.87③/1.03④	1.30④/1.74⑤

Table 41.2
Evaporative Cooler Amp Draws for Outdoor Units (Digit 22 = 3, 4, 5, 6, A, B, C, or D)

Model Size	Digit 14 (Supply Voltage)						
	A (115/60/1)	B ② (208/60/1)	C (230/60/1)	D ② (208/60/3)	E (230/60/3)	F ⑥ (460/60/3)	G ⑥ (575/60/3)
All	1.00	1.20	0.50	1.20	0.50	0.54	0.43

① When 2 amp draws are listed, the first is for Outdoor units and the second is for Separated Combustion units.

② Amp draw is for a 250 VA transformer.

③ Amp draw is for a 500 VA transformer.

④ Amp draw is for a 750 VA transformer.

⑤ Amp draw is for a 1000 VA transformer.

⑥ Only include amp draw for gravity vented models. For power vented models, the step down transformer amp draw is included in the Power Exhauster Motor Amp Draw. Amp draw is for 250 VA step down transformer.

Table 42.1
Motor Data for Digit 14 = A - 115V/60Hz/1Ph

Digits 17&18	Motor Size (HP)	Motor Type ①	Frame Size	Amp. Draw	Service Factor	Weight (lbs)	Efficiency (%) ②
A1	1/3 ③	ODP	56	6.6	1.35	25	N/A
A5	1/3 ③	TENV	48	5.0	1.00	25	N/A
B1	1/2 ③	ODP	56	9.0	1.25	23	N/A
B5	1/2 ③	TEFC	56	8.0	1.15	28	N/A
C1	3/4 ③	ODP	56	11.0	1.25	25	N/A
C5	3/4 ③	TE	56	11.0	1.15	30	N/A
D1	1 ③	ODP	56	13.4	1.15	32	N/A
D5	1 ③	TE	56	13.4	1.15	37	N/A
E1	1 1/2 ③	ODP	56	18.0	1.15	40	N/A
E5	1 1/2 ③	TE	56	15.2	1.15	45	N/A
F1 or R1	2	ODP	145T	21.0	1.15	49	N/A
F5 or R5	2	TE	182T	20.0	1.15	54	N/A
G1 or S1	3	ODP	184T	34.0	1.15	81	N/A
G5 or S5	3	TE	184T	32.0	1.00	83	N/A

Table 42.2 - Motor Data for Digit 14 = B - 208V/60Hz/1Ph

Digits 17&18	Motor Size (HP)	Motor Type ①	Frame Size	Amp. Draw	Service Factor	Weight (lbs)	Efficiency (%) ②
A1	1/3 ③	ODP	56	3.0	1.35	25	N/A
B1	1/2 ③	ODP	56	4.1	1.25	23	N/A
B5	1/2 ③	TEFC	56	4.0	1.15	28	N/A
C1	3/4 ③	ODP	56	5.5	1.25	25	N/A
C5	3/4 ③	TE	56	5.4	1.15	30	N/A
D1	1 ③	ODP	56	6.8	1.15	32	N/A
D5	1 ③	TE	56	6.8	1.15	37	N/A
E1	1 1/2 ③	ODP	56	9.3	1.15	40	N/A
E5	1 1/2 ③	TE	56	8.2	1.15	45	N/A
F1 or R1	2	ODP	145T	11.3	1.15	49	N/A
F5 or R5	2	TE	182T	10.8	1.15	54	N/A
H1 or T1	5	ODP	184T	23.0	1.15	87	N/A
H5 or T5	5	TE	184T	22.8	1.00	86	N/A

Table 42.3 - Motor Data for Digit 14 = C - 230V/60Hz/1Ph

Digits 17&18	Motor Size (HP)	Motor Type ①	Frame Size	Amp. Draw	Service Factor	Weight (lbs)	Efficiency (%) ②
A1	1/3 ③	ODP	56	3.3	1.35	25	N/A
A5	1/3 ③	TENV	48	2.5	1.00	25	N/A
B1	1/2 ③	ODP	56	4.5	1.25	23	N/A
B5	1/2 ③	TEFC	56	4.0	1.15	28	N/A
C1	3/4 ③	ODP	56	5.5	1.25	25	N/A
C5	3/4 ③	TE	56	5.5	1.15	30	N/A
D1	1 ③	ODP	56	6.7	1.15	32	N/A
D5	1 ③	TE	56	6.7	1.15	37	N/A
E1	1 1/2 ③	ODP	56	9.0	1.15	40	N/A
E5	1 1/2 ③	TE	56	7.6	1.15	45	N/A
F1 or R1	2	ODP	145T	10.5	1.15	49	N/A
F5 or R5	2	TE	182T	10.0	1.15	54	N/A
G1 or S1	3	ODP	184T	17.0	1.15	81	N/A
G5 or S5	3	TE	184T	16.0	1.00	83	N/A
H1 or T1	5	ODP	184T	22.0	1.15	87	N/A
H5 or T5	5	TE	184T	20.2	1.00	86	N/A

① Refer to page 44 for Motor Type abbreviations.

② Motors manufacturers do not rate single-phase motors for efficiency.

③ Single phase motors, 1-1/2HP and smaller, feature integral thermal overload protection. 2HP and larger require external protection. The optional motor starter for those sizes provides overcurrent protection.

Table 43.1
Motor Data for Digit 14 = D - 208V/60Hz/3Ph ①

Digits 17&18	Motor Size (HP)	Motor Type ②	Frame Size	Amp. Draw	Service Factor	Weight (lbs)	Efficiency (%)
A1 or L1	1/3	ODP	56	1.5	1.35	17	N/A
A5 or L5	1/3	TE	48	1.2	1.00	15	N/A
B1 or M1	1/2	ODP	56	2.1	1.25	18	N/A
B5 or M5	1/2	TEFC	56	2.1	1.15	18	N/A
C1 or N1	3/4	ODP	56	2.7	1.25	21	N/A
C5 or N5	3/4	TEFC	56	2.7	1.15	30	N/A
D1 or P1	1	ODP	143T	3.1	1.15	40	82.5%
D2 or P2	1	ODP HE	143T	3.2	1.15	30	84.0%
D5 or P5	1	TEFC	56	3.5	1.15	28	N/A
D6 or P6	1	TE HE	143T	3.5	1.15	68	84.5%
E1 or Q1	1 1/2	ODP	145T	5.9	1.15	43	80.0%
E2 or Q2	1 1/2	ODP	145T	4.8	1.00	35	89.5%
E5 or Q5	1 1/2	TEFC	56	4.8	1.15	33	N/A
E6 or Q6	1 1/2	TE HE	145T	4.9	1.15	62	84.0%
F1 or R1	2	ODP	145T	7.2	1.15	43	82.0%
F2 or R2	2	ODP	145T	5.8	1.00	74	89.5%
F5 or R5	2	TE	145T	7.0	1.15	52	84.0%
F6 or R6	2	TE HE	145T	6.5	1.15	66	86.5%
G1 or S1	3	ODP	182T	10.0	1.15	78	81.5%
G2 or S2	3	ODP HE	182T	8.9	1.15	83	89.5%
G5 or S5	3	TE	182T	10.0	1.15	83	87.5%
G6 or S6	3	TE HE	182T	9.4-9.1	1.15	92	88.5%
H1 or T1	5	ODP	184T	16.0	1.15	76	84.0%
H2 or T2	5	ODP HE	182T	15.7	1.15	94	89.5%
H5 or T5	5	TE	184T	14.2	1.15	90	87.5%
H6 or T6	5	TE HE	184T	15.0	1.15	99	88.5%
I1 or W1	7 1/2	ODP	213T	26.9	1.15	106	81.5%
I2 or W2	7 1/2	ODP HE	213T	22.3	1.15	141	91.7%
I5 or W5	7 1/2	TE	213T	24.0	1.15	126	89.5%
I6 or W6	7 1/2	TE HE	213T	22.0	1.15	158	90.2%
J1 or X1	10	ODP	215T	32.6	1.15	120	84.0%
J2 or X2	10	ODP HE	215T	29.0	1.15	126	91.7%
J5 or X5	10	TE	215T	29.0	1.15	130	87.5%
J6 or X6	10	TE HE	215T	27.6	1.15	200	90.2%
K1 or Y1	15	ODP	254T	45.6	1.15	147	87.5%
K2 or Y2	15	ODP HE	254T	43.4	1.15	220	93.0%
K5 or Y5	15	TE	254T	42.0	1.15	250	91.0%
K6 or Y6	15	TE HE	254T	40.3	1.15	259	91.7%
V1 or Z1	20	ODP	256T	61.6	1.15	200	87.5%
V2 or Z2	20	ODP HE	256T	57.0	1.15	250	93.6%
V6 or Z6	20	TE HE	256T	54.0	1.15	290	91.7%

① Motors have no thermal overload.

② Refer to page 44 for Motor Type abbreviations.

Table 43.2
Motor Data for Digit 14 = E - 230V/60Hz/3Ph ①

Digits 17&18	Motor Size (HP)	Motor Type ②	Frame Size	Amp. Draw	Service Factor	Weight (lbs)	Efficiency (%)
A1 or L1	1/3	ODP	56	1.6	1.35	17	N/A
A5 or L5	1/3	TE	48	1.2	1.00	15	N/A
B1 or M1	1/2	ODP	56	2.2	1.25	18	N/A
B5 or M5	1/2	TEFC	56	2.2	1.15	18	N/A
C1 or N1	3/4	ODP	56	2.8	1.25	21	N/A
C5 or N5	3/4	TEFC	56	2.8	1.15	30	N/A
D1 or P1	1	ODP	143T	3.1	1.15	36	82.5%
D2 or P2	1	ODP HE	143T	3.2	1.15	30	84.0%
D5 or P5	1	TEFC	56	3.6	1.15	28	N/A
D6 or P6	1	TE HE	143T	3.0	1.15	68	85.5%
E1 or Q1	1 1/2	ODP	145T	4.4	1.15	42	84.0%
E2 or Q2	1 1/2	ODP	145T	5.6	1.00	35	89.5%
E5 or Q5	1 1/2	TEFC	56	4.8	1.15	33	N/A
E6 or Q6	1 1/2	TE HE	145T	5.0	1.15	62	86.5%
F1 or R1	2	ODP	145T	5.8	1.15	43	84.0%
F2 or R2	2	ODP	145T	5.8	1.00	74	89.5%
F5 or R5	2	TE	145T	5.8	1.15	52	84.0%
F6 or R6	2	TE HE	145T	6.0	1.15	64	85.5%
G1 or S1	3	ODP	182T	9.4	1.15	81	86.5%
G2 or S2	3	ODP HE	182T	8.6	1.15	74	89.5%
G5 or S5	3	TE	182T	8.2	1.15	83	87.5%
G6 or S6	3	TE HE	182T	8.0	1.15	110	89.5%
H1 or T1	5	ODP	184T	14.0	1.15	87	87.5%
H2 or T2	5	ODP HE	184T	13.6	1.15	94	89.5%
H5 or T5	5	TE	184T	13.0	1.15	90	87.5%
H6 or T6	5	TE HE	184T	13.0	1.15	117	90.2%
I1 or W1	7 1/2	ODP	213T	19.6	1.15	121	88.5%
I2 or W2	7 1/2	ODP HE	213T	19.4	1.15	160	91.7%
I5 or W5	7 1/2	TE	213T	20.0	1.15	126	89.5%
I6 or W6	7 1/2	TE HE	213T	19.2	1.15	194	91.7%
J1 or X1	10	ODP	215T	26.8	1.15	138	89.5%
J2 or X2	10	ODP HE	215T	25.2	1.15	220	91.7%
J5 or X5	10	TE	215T	26.0	1.00	138	89.5%
J6 or X6	10	TE HE	215T	25.0	1.15	213	90.2%
K1 or Y1	15	ODP	254T	38.6	1.15	215	91.0%
K2 or Y2	15	ODP HE	254T	37.8	1.15	217	93.0%
K5 or Y5	15	TE	254T	40.0	1.15	250	91.0%
K6 or Y6	15	TE HE	254T	38.0	1.15	322	92.4%
V1 or Z1	20	ODP	256T	50.0	1.15	233	91.0%
V2 or Z2	20	ODP HE	256T	49.0	1.15	250	93.6%
V5 or Z5	20	TEFC	256T	51.0	1.15	287	91.0%
V6 or Z6	20	TE HE	256T	48.2	1.15	368	93.0%

① Motors have no thermal overload.

② Refer to page 44 for Motor Type abbreviations.

Table 44.1
Motor Data for Digit 14 = F - 460V/60Hz/3Ph ①

Digits 17&18	Motor Size (HP)	Motor Type ②	Frame Size	Amp. Draw	Service Factor	Weight (lbs)	Efficiency (%)
A1 or L1	1/3	ODP	56	0.8	1.35	17	N/A
A3 or L3	1/3	TE	48	0.6	1.00	15	N/A
B1 or M1	1/2	ODP	56	1.1	1.25	18	N/A
B5 or M5	1/2	TEFC	56	1.1	1.15	18	N/A
C1 or N1	3/4	ODP	56	1.4	1.25	21	N/A
C5 or N5	3/4	TEFC	56	1.4	1.15	30	N/A
D1 or P1	1	ODP	143T	1.6	1.15	36	82.5%
D2 or P2	1	ODP HE	143T	1.5	1.15	30	84.0%
D5 or P5	1	TEFC	56	1.8	1.15	28	N/A
D6 or P6	1	TE HE	143T	1.5	1.15	68	85.5%
E1 or Q1	1 1/2	ODP	145T	2.2	1.15	42	84.0%
E2 or Q2	1 1/2	ODP	145T	2.4	1.00	35	89.5%
E5 or Q5	1 1/2	TEFC	56	2.4	1.15	33	N/A
E6 or Q6	1 1/2	TE HE	145T	2.5	1.15	62	86.5%
F1 or R1	2	ODP	145T	2.9	1.15	43	84.0%
F2 or R2	2	ODP	145T	2.9	1.00	74	89.5%
F5 or R5	2	TE	145T	2.9	1.15	52	84.0%
F6 or R6	2	TE HE	145T	3.0	1.15	64	85.5%
G1 or S1	3	ODP	182T	4.5	1.15	81	86.5%
G2 or S2	3	ODP HE	182T	4.3	1.15	74	89.5%
G5 or S5	3	TE	182T	4.1	1.15	83	87.5%
G6 or S6	3	TE HE	182T	4.0	1.15	110	89.5%
H1 or T1	5	ODP	184T	7.0	1.15	87	87.5%
H2 or T2	5	ODP HE	184T	6.8	1.15	94	89.5%
H5 or T5	5	TE	184T	6.5	1.15	90	87.5%
H6 or T6	5	TE HE	184T	6.5	1.15	117	90.2%
I1 or W1	7 1/2	ODP	213T	9.8	1.15	121	88.5%
I2 or W2	7 1/2	ODP HE	213T	9.7	1.15	160	91.7%
I5 or W5	7 1/2	TE	213T	10.0	1.15	126	89.5%
I6 or W6	7 1/2	TE HE	213T	9.6	1.15	194	91.7%
J1 or X1	10	ODP	215T	13.4	1.15	138	89.5%
J2 or X2	10	ODP HE	215T	12.6	1.15	220	91.7%
J5 or X5	10	TE	215T	13.0	1.00	138	89.5%
J6 or X6	10	TE HE	215T	12.5	1.15	213	90.2%
K1 or Y1	15	ODP	254T	19.3	1.15	215	91.0%
K2 or Y2	15	ODP HE	254T	18.9	1.15	217	93.0%
K5 or Y5	15	TE	254T	20.0	1.15	250	91.0%
K6 or Y6	15	TE HE	254T	19.0	1.15	322	92.4%
V1 or Z1	20	ODP	256T	25.0	1.15	233	91.0%
V2 or Z2	20	ODP HE	256T	24.5	1.15	250	93.6%
V5 or Z5	20	TEFC	256T	25.5	1.15	287	91.0%
V6 or Z6	20	TE HE	256T	24.1	1.15	368	93.0%

① Motors have no thermal overload.

Table 44.2
Motor Data for Digit 14 = G - 575V/60Hz/3Ph ①

Digits 17&18	Motor Size (HP)	Motor Type ②	Frame Size	Amp. Draw	Service Factor	Weight (lbs)	Efficiency (%)
A5 or L5	1/3	TEFC	56	0.6	1.15	16	N/A
B1 or M1	1/2	ODP	56	0.9	1.25	25	N/A
B5 or M5	1/2	TEFC	56	0.9	1.15	24	N/A
C1 or N1	3/4	ODP	56	0.9	1.25	28	N/A
C5 or N5	3/4	TEFC	56	1.1	1.15	33	N/A
D1 or P1	1	ODP	143T	1.1	1.15	41	82.5%
D5 or P5	1	TEFC	56	1.5	1.15	28	77.0%
D6 or P6	1	TE HE	143T	1.2	1.15	68	85.5%
E1 or Q1	1 1/2	ODP	145T	1.8	1.15	48	84.0%
E5 or Q5	1 1/2	TEFC	145T	2.0	1.15	72	84.0%
E6 or Q6	1/12	TE HE	145T	1.7	1.15	66	85.5%
F1 or R1	2	ODP	145T	2.3	1.15	50	84.0%
F5 or R5	2	TEFC	145T	2.3	1.15	65	84.0%
F6 or R6	2	TE HE	145T	2.4	1.15	66	86.5%
G1 or S1	3	ODP	182T	3.4	1.15	72	86.5%
G5 or S5	3	TEFC	182T	3.4	1.15	98	87.5%
G6 or S6	3	TE HE	182T	3.2	1.15	100	89.5%
H1 or T1	5	ODP	184T	5.2	1.15	91	87.5%
H5 or T5	5	TEFC	184T	5.2	1.15	89	87.5%
H6 or T6	5	TE HE	184T	5.2	1.15	117	89.5%
I1 or W1	7 1/2	ODP	213T	7.8	1.15	113	88.5%
I5 or W5	7 1/2	TEFC	213T	8.0	1.15	142	89.0%
I6 or W6	7 1/2	TE HE	213T	7.6	1.15	192	90.2%
J1 or X1	10	ODP	215T	10.3	1.15	123	89.5%
J5 or X5	10	TE	215T	10.4	1.15	154	89.5%
J6 or X6	10	TE HE	215T	9.6	1.15	200	90.2%
K1 or Y1	15	ODP	254T	15.4	1.15	184	91.0%
K5 or Y5	15	TE	254T	16.0	1.15	250	91.0%
K6 or Y6	15	TE HE	254T	15.2	1.15	326	92.4%
V1 or Z1	20	ODP	256T	20.8	1.15	255	91.0%
V5 or Z5	20	TEFC	256T	20.4	1.15	287	91.0%
V6 or Z6	20	TE HE	256T	19.5	1.15	368	93.0%

① Motors have no thermal overload

② Motor Type Abbreviations

- ODP Open Drip Proof
- ODP HE Open Drip Proof, High Efficiency
- TE Totally Enclosed
- TEFC Totally Enclosed, Fan Cooled
- TE HE Totally Enclosed, High Efficiency
- TENV Totally Enclosed, Non-Ventilating

THIS PAGE INTENTIONALLY LEFT BLANK

Figure 46.1
DBG Indoor Gravity Vented Blower Package Unit Dimensions

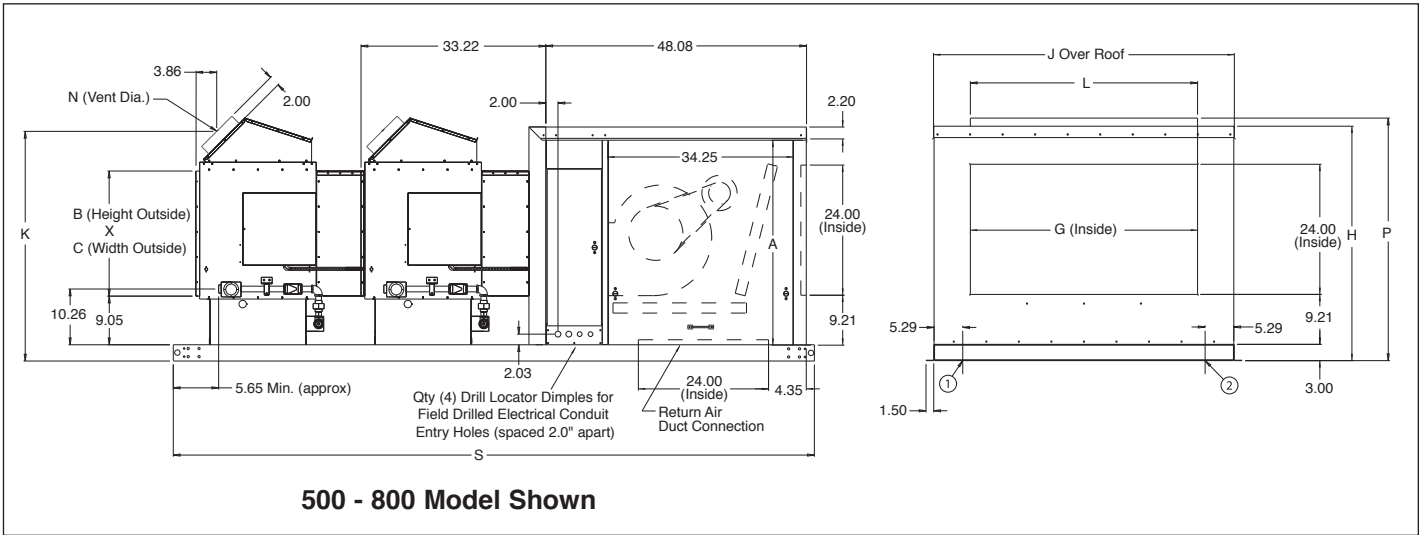

Figure 46.2
DCG Indoor Gravity Vented Cooling Package Unit Dimensions

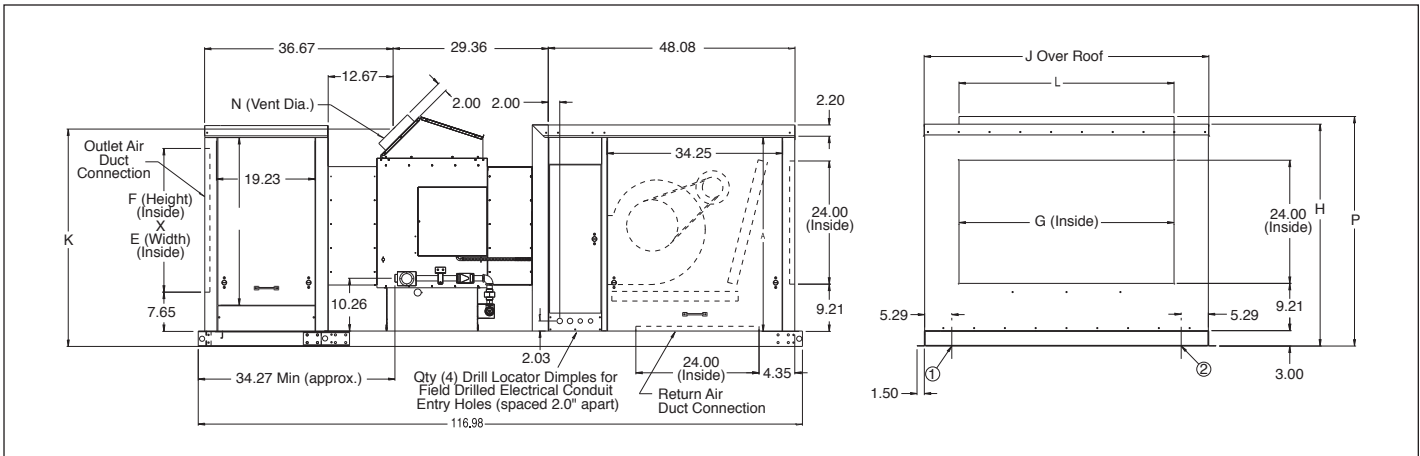

Table 46.1
DBG/DCG Indoor Gravity Vented Unit Dimensions (All dimensions in Inches)

Model Size	Blower Type (Digit 16)	Qty. of Furnaces	Dimensions														Gas Conn.
			A	B	C	D	E	F	G	H	J	K	L	N	P	S	
75	All	1	37.75	19.07	15.21	28.75	18.00	25.50	20.02	39.23	32.06	38.37	12.65	5	40.80	87.77	1/2
100/125	All	1	37.75	19.07	17.70	28.75	21.00	25.50	20.02	39.23	34.56	38.37	15.14	6	40.80	87.77	1/2
150/175	All	1	37.75	19.07	21.96	28.75	24.00	25.50	23.99	39.23	38.82	38.37	19.41	7	40.80	87.77	1/2
200/225	All	1	37.75	23.07	24.09	32.75	27.00	30.50	23.99	43.23	40.94	42.37	21.60	7	44.80	87.77	1/2 / 3/4
250/300	E, F, G, or H	1	37.75	23.07	27.13	32.75	30.00	30.50	29.96	43.23	44.05	42.37	24.60	8/10	44.80	87.77	3/4
350/400	E, F, G, or H	1	37.75	23.07	38.63	32.75	42.00	30.50	41.90	43.23	55.57	42.37	36.14	10	44.80	87.77	3/4
500/600	G or H	2	37.75	23.07	27.13	32.75	n/a	n/a	29.96	43.23	44.05	42.37	24.60	8/10	44.80	120.90	3/4
700/800	G or H	2	37.75	23.07	38.63	32.75	n/a	n/a	41.90	43.23	55.57	42.37	36.14	10	44.80	120.90	3/4

① For Right Hand Access Units - Drill Locator Dimples for Field Drilled Electrical Conduit Entry Holes (spaced 2.0" apart)

② For Left Hand Access Units - Drill Locator Dimples for Field Drilled Electrical Conduit Entry Holes (spaced 2.0" apart)

Figure 47.1

DBG Indoor Gravity Vented Blower Package Unit Dimensions with Blower Type I, J, K, or L

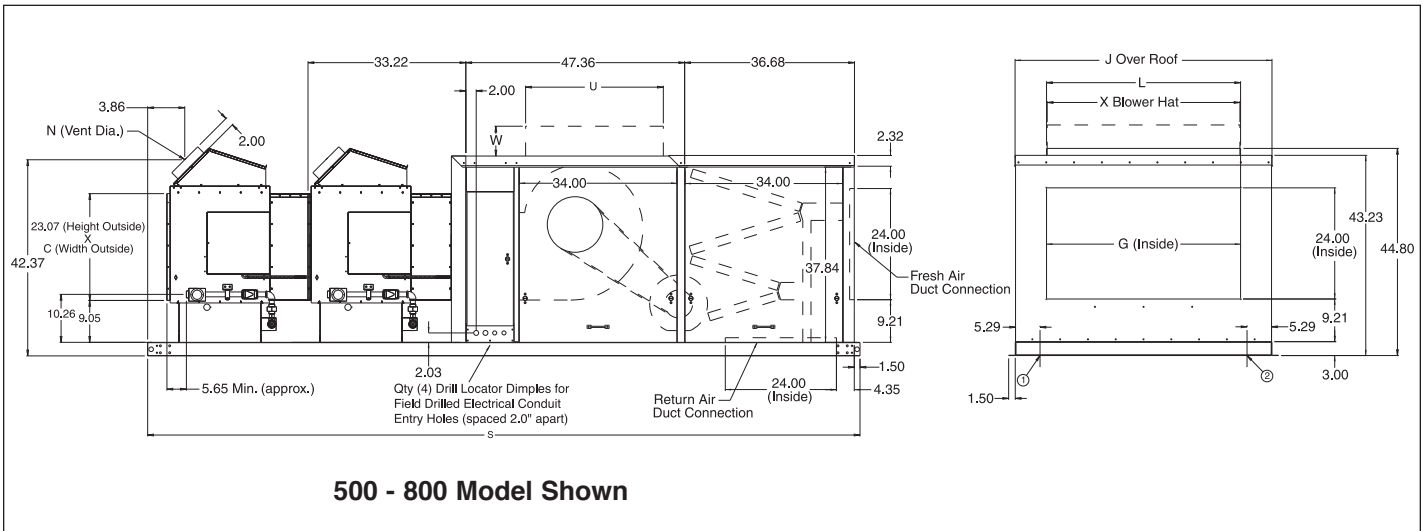

Figure 47.2

DCG Indoor Gravity Vented Cooling Package Unit Dimensions with Blower Type I, J, K, or L

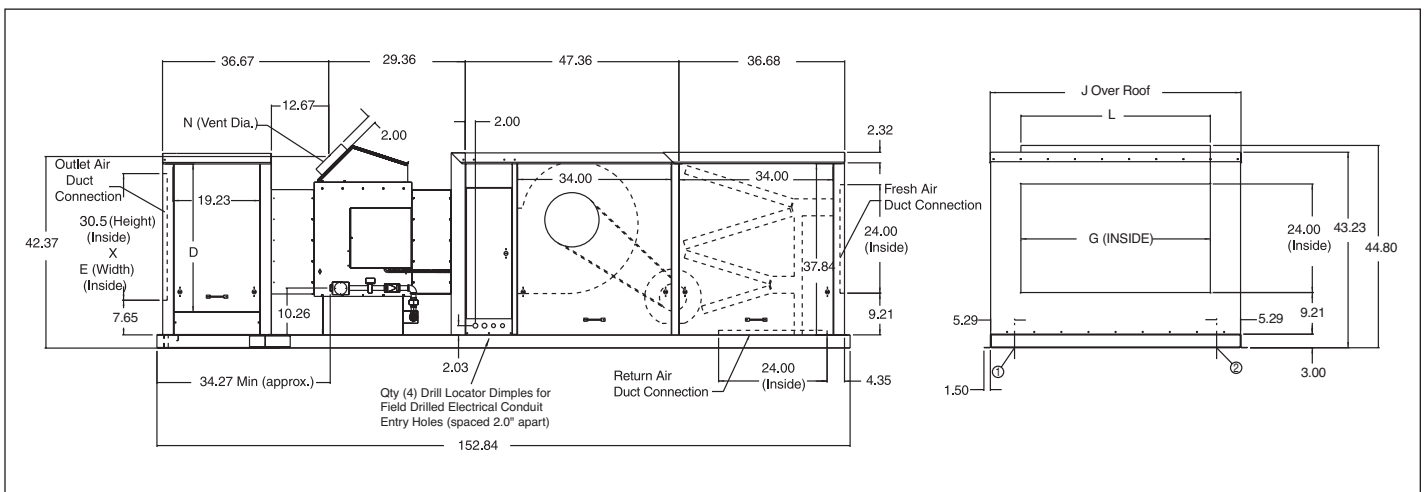

Table 47.1

DBG/DCG Indoor Gravity Vented Unit Dimensions with Blower Type I, J, K, or L (All dimensions in inches)

Model Size	Blower Type (Digit 16)	Qty. of Furnaces	Dimensions										Gas Conn.
			C	E	G	J	L	N	S	U ^③	W ^③	X ^③	
250/300	I, J, or K	1	27.13	30.00	29.96	44.05	24.60	8/10	123.35	n/a	n/a	n/a	3/4
350/400	I, J, or K	1	38.63	42.00	41.90	55.07	36.14	10	123.35	n/a	n/a	n/a	3/4
500/600	I, J, K, or L	2	27.13	n/a	29.96	44.05	24.60	8/10	156.76	29.74	6.5	41.62	3/4
700/800	I, J, K, or L	2	38.63	n/a	41.90	55.57	36.14	10	156.76	29.74	6.5	41.62	3/4
840/960	I, J, K, or L	3	38.63	n/a	41.90	55.57	36.14	10	185.99	29.74	6.5	41.62	3/4

① For Right Hand Access Units - Drill Locator Dimples for Field Drilled Electrical Conduit Entry Holes (spaced 2.0" apart)

② For Left Hand Access Units - Drill Locator Dimples for Field Drilled Electrical Conduit Entry Holes (spaced 2.0" apart)

③ Applies to units with Digit 16 = L only.

Figure 48.1 - DBP Indoor Power Vented Blower Package Unit Dimensions

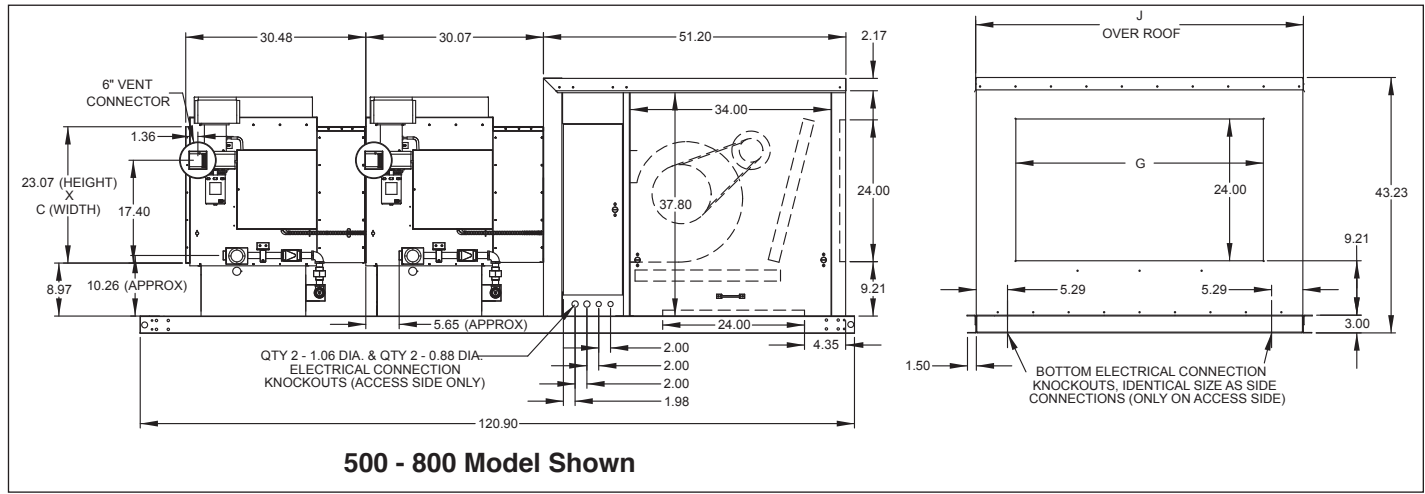

Figure 48.2 - DCP Indoor Power Vented Cooling Package Unit Dimensions

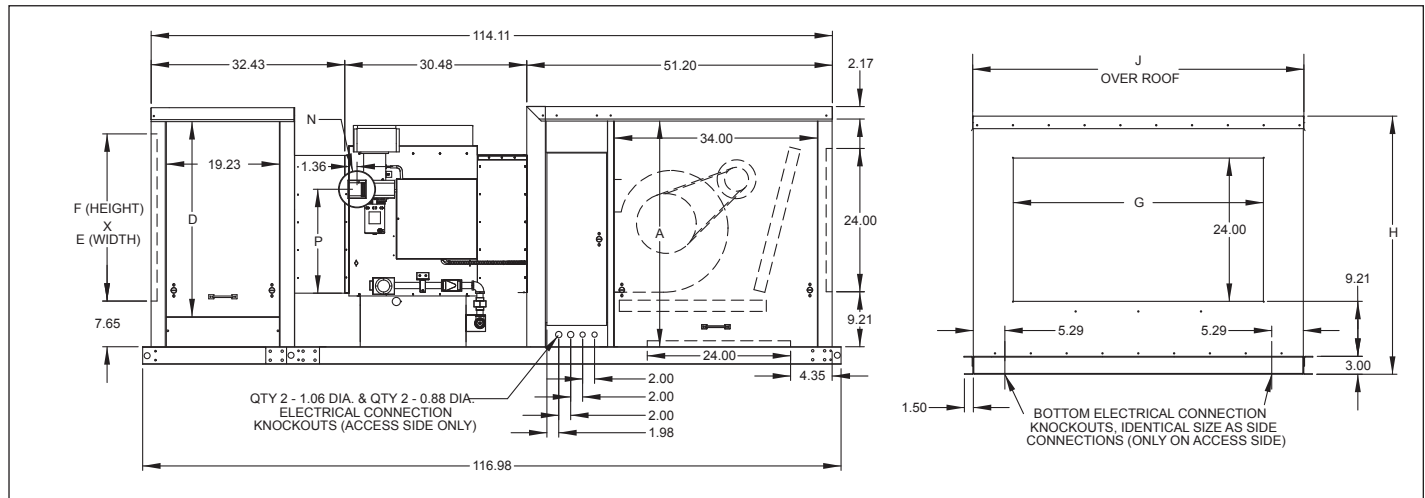

Table 48.1 - DBP/DCP Indoor Power Vented Unit Dimensions (All dimensions in inches)

Model Size	Blower Type (Digit 16)	Qty. of Furnaces	Dimensions														Gas Conn.
			A	B	C	D	E	F	G	H	J	K	L	N	P	S	
75	All	1	37.75	19.07	15.21	28.75	18.00	25.00	20.02	39.23	32.06	38.37	12.65	5	40.80	87.77	1/2
100/125	All	1	37.75	19.07	17.70	28.75	21.00	25.00	20.02	39.23	34.56	38.37	15.14	6	40.80	87.77	1/2
150/175	All	1	37.75	19.07	21.96	28.75	24.00	25.00	23.99	39.23	38.82	38.37	19.41	7	40.80	87.77	1/2
200/225	All	1	37.75	23.07	24.09	32.75	27.00	28.00	23.99	43.23	40.94	42.37	21.60	7	44.80	87.77	1/2 / 3/4
250/300	E, F, G, or H	1	37.75	23.07	27.13	32.75	30.00	28.00	29.96	43.23	44.05	42.37	24.60	8/10	44.80	87.77	3/4
350/400	E, F, G, or H	1	37.75	23.07	38.63	32.75	42.00	28.00	41.90	43.23	55.57	42.37	36.14	10	44.80	87.77	3/4
500/600	G or H	2	37.75	23.07	27.13	32.75	n/a	n/a	29.96	43.23	44.05	42.37	24.60	8/10	44.80	120.90	3/4
700/800	G or H	2	37.75	23.07	38.63	32.75	n/a	n/a	41.90	43.23	55.57	42.37	36.14	10	44.80	120.90	3/4

① For Right Hand Access Units - Location of electrical connection knock-outs are identical sizes as side electrical connections.

② For Left Hand Access Units - Location of electrical connection knock-outs are identical sizes as side electrical connections.

Figure 49.1 - DBP Indoor Power Vented Blower Package Unit Dimensions with Blower Type I, J, K, or L

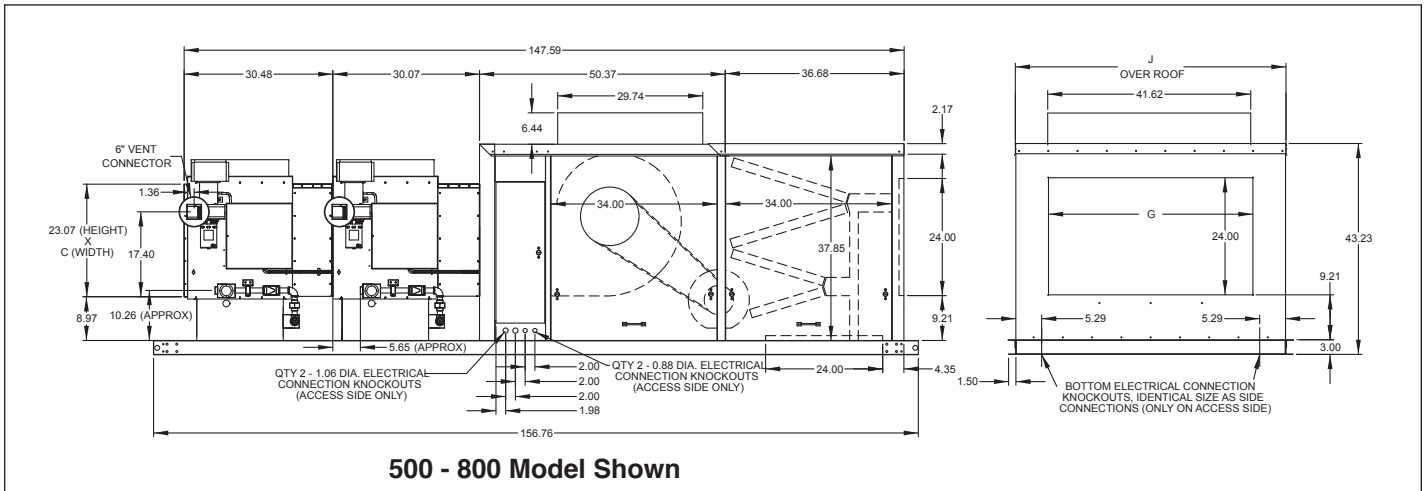

Figure 49.2 - DCP Indoor Power Vented Cooling Package Unit Dimensions with Blower Type I, J, K, or L

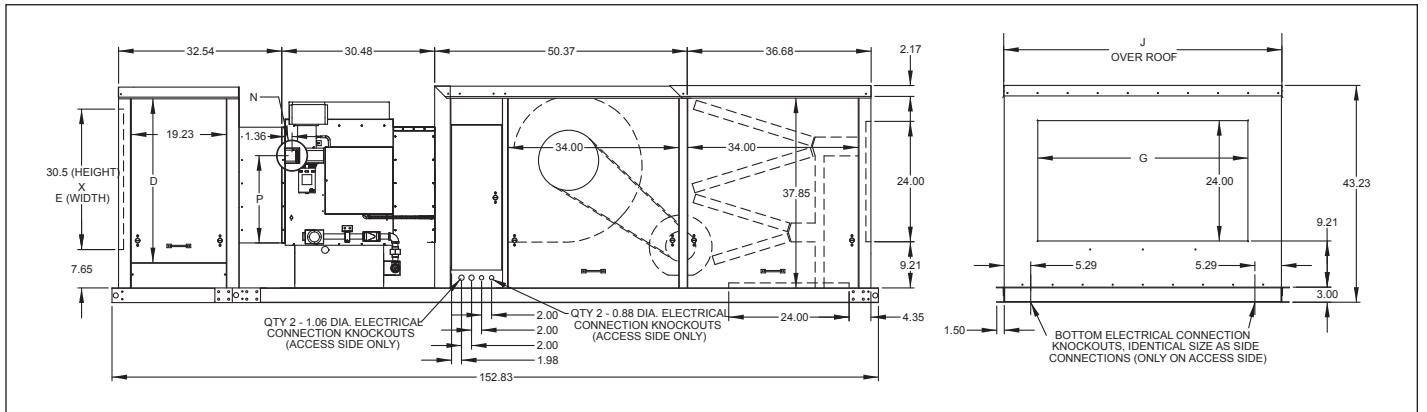
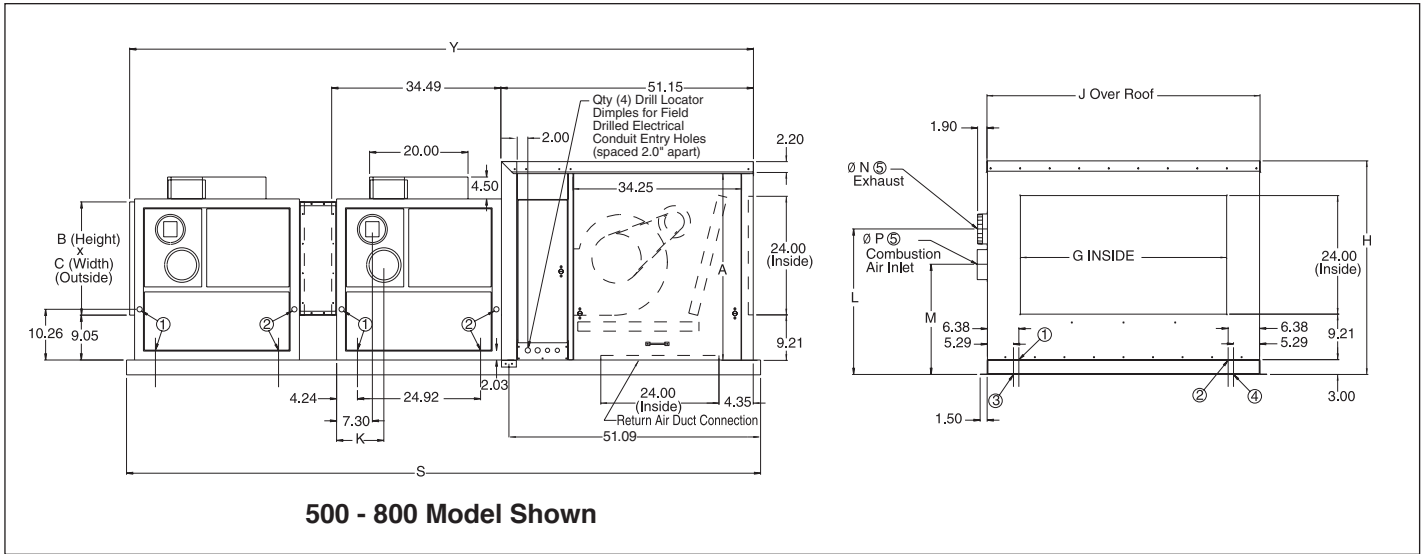

Table 49.1 - DBP/DCP Indoor Power Vented Unit Dimensions with Blower Type I, J, K, or L (All dimensions in inches)

Model Size	Blower Type (Digit 16)	Qty. of Furnaces	Dimensions										Gas Conn.
			C	E	G	J	L	N	S	U ^③	W ^③	X ^③	
250/300	I, J, or K	1	27.13	30.00	29.96	44.05	24.60	8/10	123.35	n/a	n/a	n/a	3/4
350/400	I, J, or K	1	38.63	42.00	41.90	55.07	36.14	10	123.35	n/a	n/a	n/a	3/4
500/600	I, J, K, or L	2	27.13	n/a	29.96	44.05	24.60	8/10	156.76	29.74	6.5	41.62	3/4
700/800	I, J, K, or L	2	38.63	n/a	41.90	55.57	36.14	10	156.76	29.74	6.5	41.62	3/4
840/960	I, J, K, or L	3	38.63	n/a	41.90	55.57	36.14	10	185.99	29.74	6.5	41.62	3/4

① For Right Hand Access Units - Location of electrical connection knock-outs are identical sizes as side electrical connections.
 ② For Left Hand Access Units - Location of electrical connection knock-outs are identical sizes as side electrical connections.
 ③ Applies to units with Digit 16 = L only.

Figure 50.1
DBS Separated Combustion Blower Package Unit Dimensions



500 - 800 Model Shown

Figure 50.2
DCS Separated Combustion Cooling Package Unit Dimensions

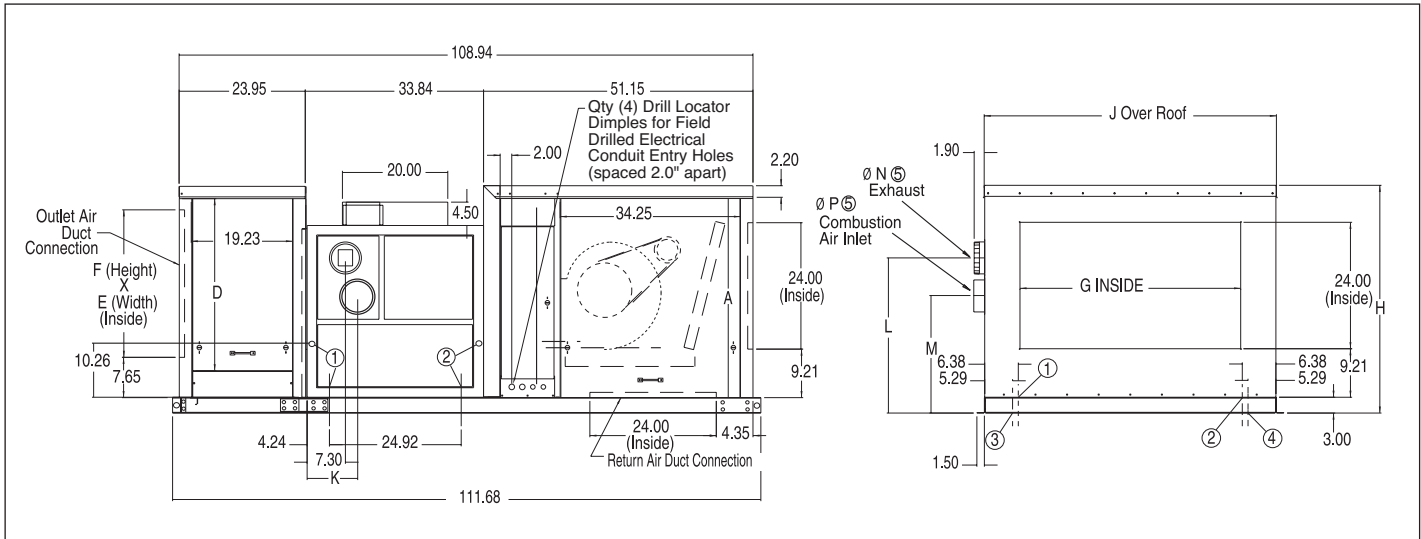

Table 50.1
DBS/DCS Indoor Separated Combustion Unit Dimensions (All dimensions in inches)

Model Size	Blower Type (Digit 16)	Qty. of Furnaces	Dimensions																Gas Conn.
			A	B	C	D	E	F	G	H	J	K	L	M	N 5	P 5	S	Y	
75	All	1	33.75	18.90	15.18	28.75	18.00	25.50	20.02	39.23	32.06	10.26	23.08	18.19	3.86	4.17	87.77	85.69	1/2
100/125	All	1	33.75	18.90	17.67	28.75	21.00	25.50	20.02	39.23	34.56	10.26	23.08	18.19	3.86	4.17	87.77	85.69	1/2
150/175	All	1	33.75	18.90	21.95	28.75	24.00	25.50	23.99	39.23	38.82	10.26	23.08	18.19	3.86	4.17	87.77	85.69	1/2
200/225	All	1	37.75	22.90	24.05	32.75	27.00	30.50	23.99	43.23	40.94	9.60	26.43	19.21	5.86	6.18	87.77	85.69	1/2
250/300	E, F, G, or H	1	37.75	22.90	27.05	32.75	30.00	30.50	29.96	43.23	44.05	9.60	26.43	19.21	5.86	6.18	87.77	85.69	3/4
350/400	E, F, G, or H	1	37.75	22.90	38.60	32.75	42.00	30.50	41.90	43.23	55.07	9.60	26.43	19.21	5.86	6.18	87.77	85.69	3/4
500/600	G or H	2	37.75	22.90	27.05	32.75	n/a	n/a	29.96	43.23	44.05	9.60	26.43	19.21	5.86	6.18	128.77	126.78	3/4
700/800	G or H	2	37.75	22.90	38.60	32.75	n/a	n/a	41.90	43.23	55.57	9.60	26.43	19.21	5.86	6.18	128.77	126.78	3/4

- ① For Right Hand Access Units - Location of drill locator dimples for field drilled gas connection entry holes - one side of unit and one on bottom.
- ② For Left Hand Access Units - Location of drill locator dimples for field drilled gas connection entry holes - one side of unit and one on bottom.
- ③ For Right Hand Access Units - Location of drill locator dimples for field drilled electrical connection entry holes - identical sizes as side electrical connections.
- ④ For Left Hand Access Units - Location of drill locator dimples for field drilled electrical connection entry holes - identical sizes as side electrical connections.
- ⑤ Nominal vent pipe size is 4" (Models 75-175) and 6" (Models 200-800). Exhaust pipe installed over collar. Combustion air pipe installed inside collar.

Figure 51.1
DBS Separated Combustion Blower Package Unit Dimensions with Blower Type I, J, K, or L

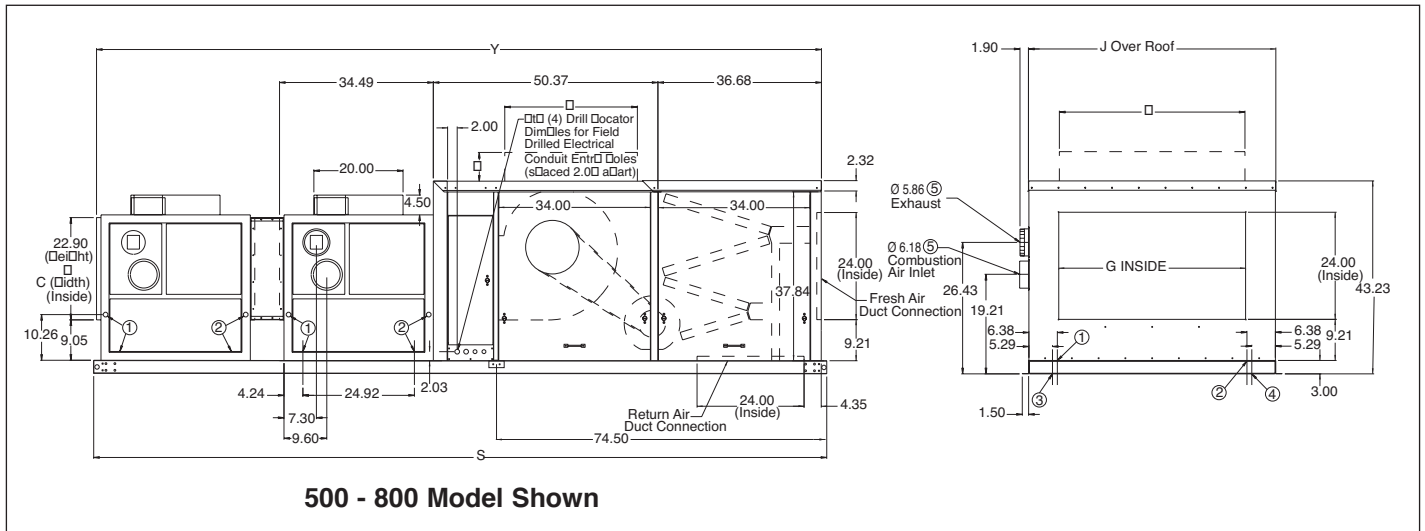

Figure 51.2
DCS Separated Combustion Cooling Package Unit Dimensions with Blower Type I, J, or K

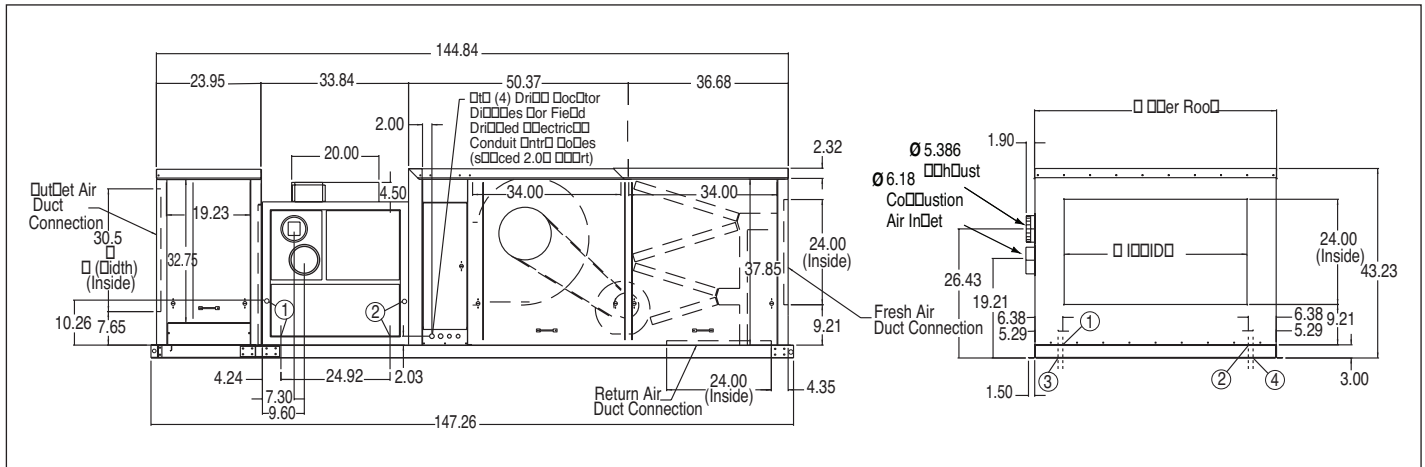

Table 51.1
DBS/DCS Indoor Separated Combustion Unit Dimensions with Blower I, J, K, or L
(All dimensions in inches)

Model Size	Blower Type (Digit 16)	Qty. of Furnaces	Dimensions									Gas Conn.
			C	E	G	J	S	U ^⑥	W ^⑥	X ^⑥	Y	
250/300	I, J, or K	1	27.05	30.00	29.96	44.05	123.63	n/a	n/a	n/a	121.53	3/4
350/400	I, J, or K	1	38.60	42.00	41.90	55.07	123.63	n/a	n/a	n/a	121.53	3/4
500/600	I, J, K, or L	2	27.05	n/a	29.96	44.05	164.63	29.74	6.50	41.62	147.55	3/4
700/800	I, J, K, or L	2	38.60	n/a	41.90	55.57	164.63	29.74	6.50	41.62	147.55	3/4
840/960	I, J, K, or L	3	38.60	n/a	41.90	55.57	205.77	29.74	6.50	41.62	203.67	3/4

- ① For Right Hand Access Units - Location of drill locator dimples for field drilled gas connection entry holes - one side of unit and one on bottom.
- ② For Left Hand Access Units - Location of drill locator dimples for field drilled gas connection entry holes - one side of unit and one on bottom.
- ③ For Right Hand Access Units - Location of drill locator dimples for field drilled electrical connection entry holes - identical sizes as side electrical connections.
- ④ For Left Hand Access Units - Location of drill locator dimples for field drilled electrical connection entry holes - identical sizes as side electrical connections.
- ⑤ Nominal vent pipe size is 4" (Models 75-175) and 6" (Models 200-800). Exhaust pipe installed over collar. Combustion air pipe installed inside collar.
- ⑥ Applies to units with Digit 16 = L only.

Figure 52.1
HBG/HBP Outdoor Blower Package Unit Dimensions

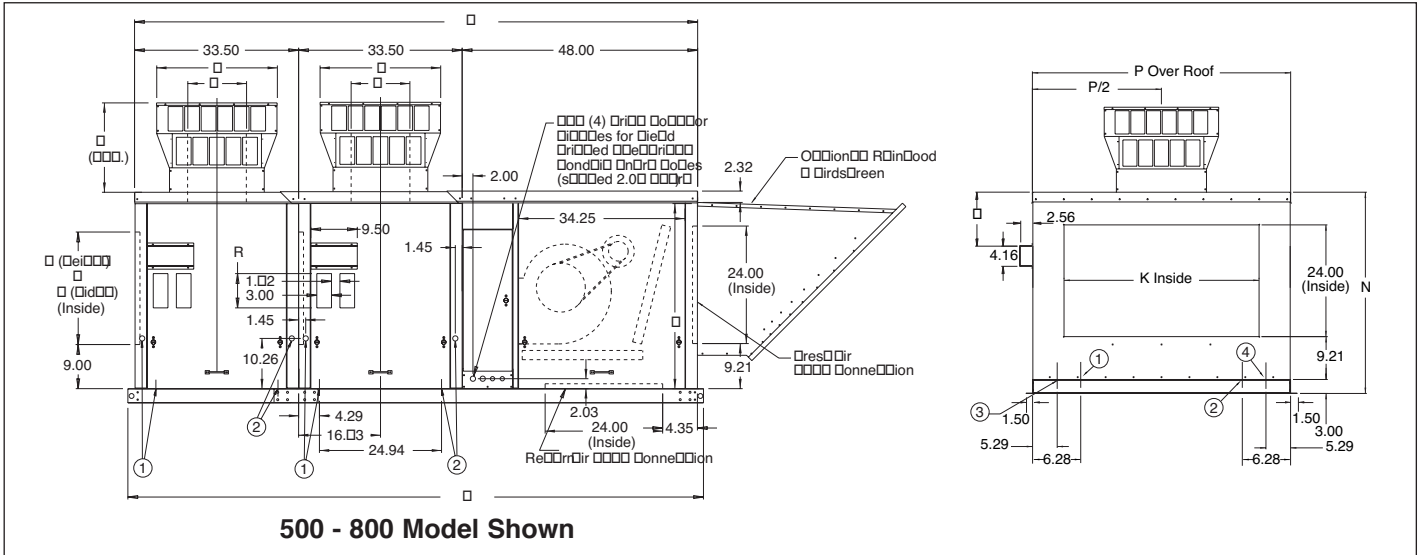

Figure 52.2
HDG/HDP Outdoor Downturn Package Unit Dimensions

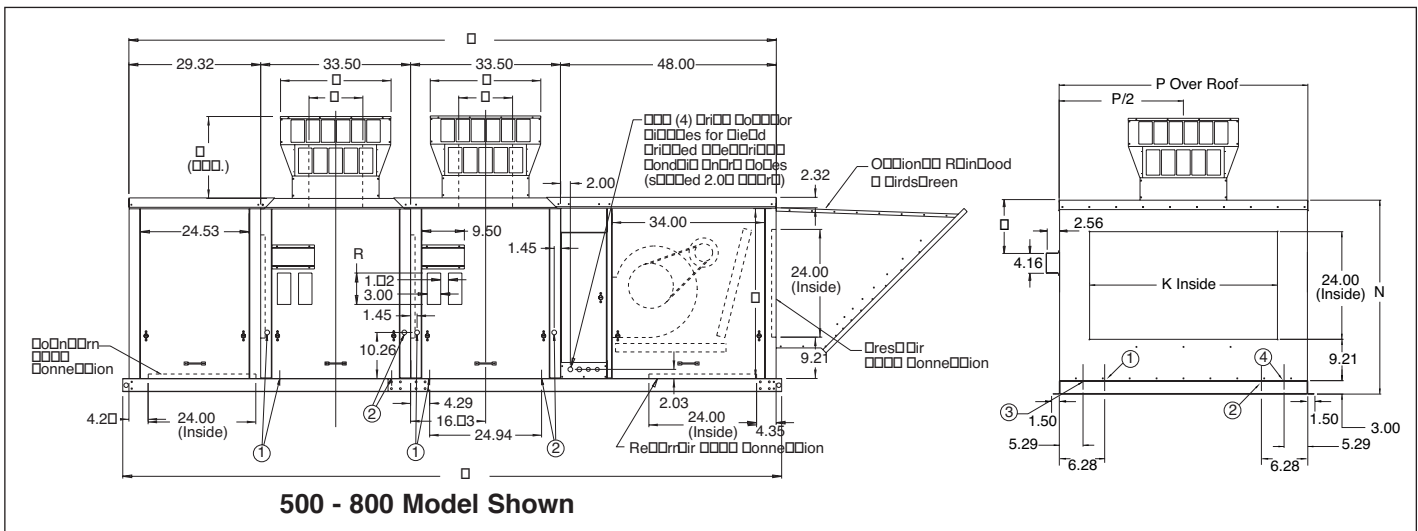

Table 52.1
HBG/HBP/HDG/HDP Outdoor Unit Dimensions (All dimensions in inches)

Model Size	Blower Type (Digit 16)	Qty. of Furnaces	Dimensions														Gas Conn.	
			A	B ⑤	C ⑤	D ⑤	E	F	K	N	P	Q ⑤	R ⑤	S	T	Y		Z
75	All	1	33.75	19.22	8.62	14.07	18.98	15.18	20.02	39.23	32.06	10.75	7.00	84.41	113.63	81.49	110.82	1/2
100/125	All	1	33.75	19.22	8.62	14.07	18.98	17.69	20.02	39.23	34.56	10.75	7.00	84.41	113.63	81.49	110.82	1/2
150/175	All	1	33.75	19.22	8.62	14.07	18.98	21.94	23.99	39.23	38.82	10.75	7.00	84.41	113.63	81.49	110.82	1/2
200/225	All	1	37.75	19.22	8.62	14.07	22.98	24.06	23.99	43.23	40.94	11.58	9.90	84.41	113.63	81.49	110.82	1/2
250/300	E, F, G, or H	1	37.75	21.31	10.62	15.05	22.98	27.09	29.96	43.23	44.05	11.58	9.90	84.41	113.63	81.49	110.82	3/4
350/400	E, F, G, or H	1	37.75	24.64	12.62	18.25	22.98	38.60	41.90	43.23	55.07	11.58	9.90	84.41	113.63	81.49	110.82	3/4
500/600	G or H	2	37.75	21.31	10.62	15.05	22.98	27.09	29.96	43.23	44.05	11.58	9.90	117.53	146.77	114.94	144.12	3/4
700/800	G or H	2	37.75	24.64	12.62	18.25	22.98	38.60	41.90	43.23	55.07	11.58	9.90	117.53	146.77	114.94	144.12	3/4

- ① For Right Hand Access Units - Location of drill locator dimples for field drilled gas connection entry holes - one side of unit and one on bottom.
- ② For Left Hand Access Units - Location of drill locator dimples for field drilled gas connection entry holes - one side of unit and one on bottom.
- ③ For Right Hand Access Units - Location of drill locator dimples for field drilled electrical connection, entry holes identical as side electrical connections.
- ④ For Left Hand Access Units - Location of drill locator dimples for field drilled electrical connection, entry holes identical as side electrical connections.
- ⑤ For Gravity Vented Models, the combustion air/vent cap is required so only dimensions B, C and D apply. For Power Vented Models, the power exhauster discharge cover and inlet louvers are included so only dimensions Q and R apply.

Figure 53.1
HBG/HBP Outdoor Blower Package Unit Dimensions with Blower Type I, J, K, or L

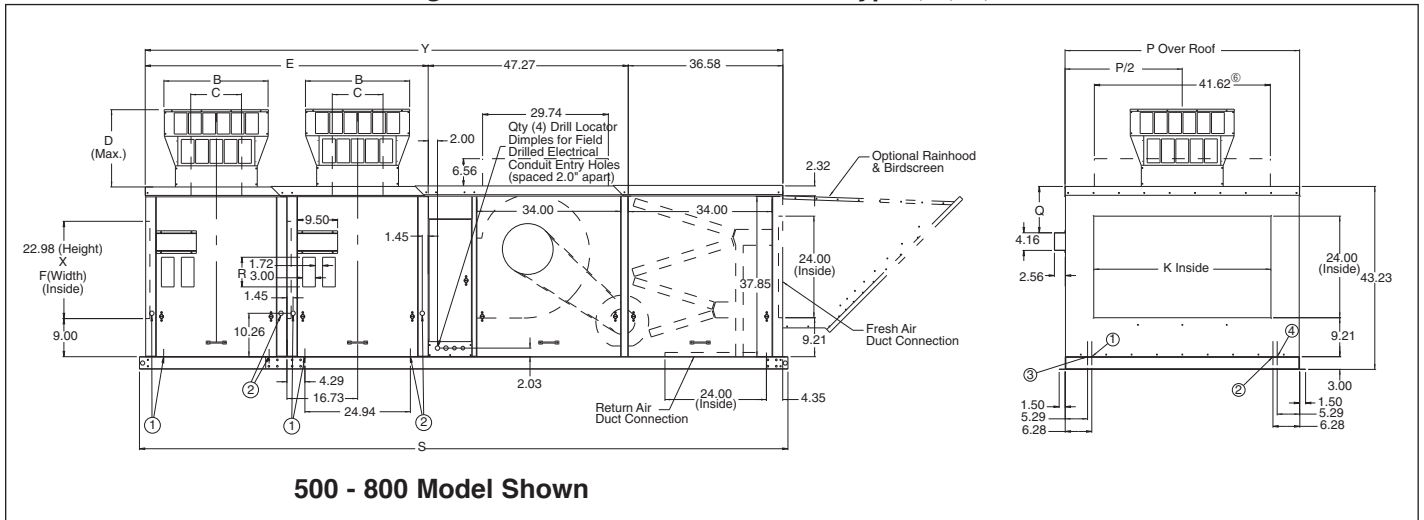

Figure 53.2
HDG/HDP Outdoor Downturn Package Unit Dimensions with Blower Type I, J, K, or L

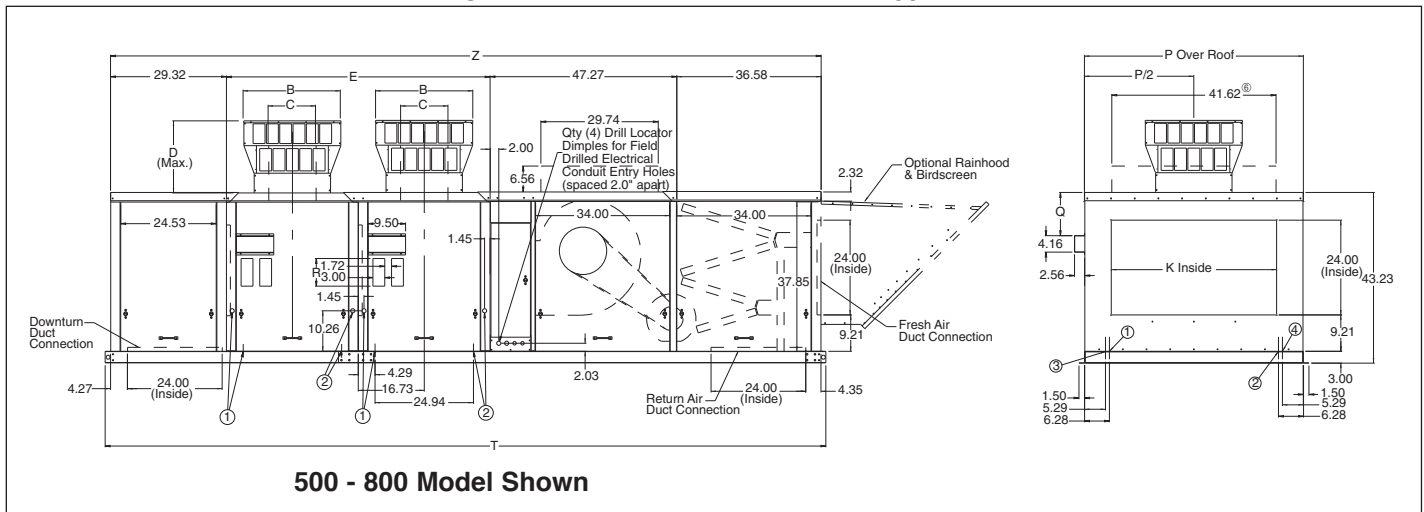
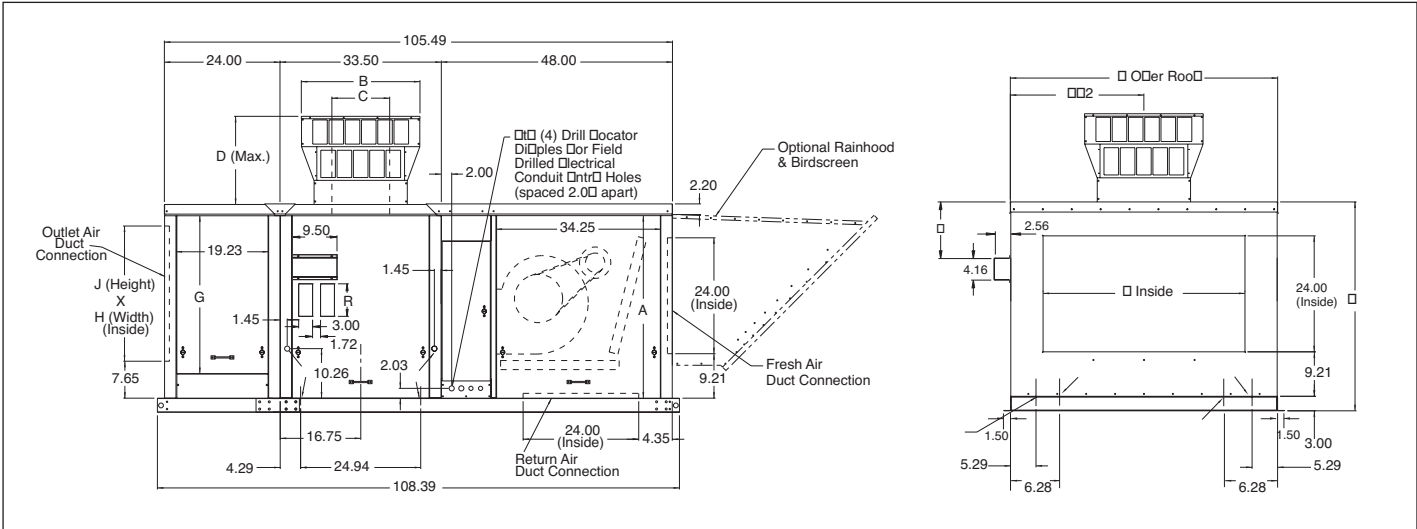

Table 53.1
HBG/HBP/HDG/HDP Outdoor Unit Dimensions with Blower I, J, K, or L (All dimensions in inches)

Model Size	Blower Type (Digit 16)	Qty. of Furnaces	Dimensions													Gas Conn.
			B ⑤	C ⑤	D ⑤	E	F	K	P	Q ⑤	R ⑤	S	T	Y	Z	
250/300	I, J, or K	1	21.31	10.62	15.05	33.50	27.09	29.96	44.05	11.58	9.90	120.00	149.22	117.34	146.66	3/4
350/400	I, J, or K	1	24.64	12.62	18.25	33.50	38.60	41.90	55.57	11.58	9.90	120.00	149.22	117.34	146.66	3/4
500/600	I, J, K, or L	2	21.31	10.62	15.05	67.00	27.09	29.96	44.05	11.58	9.90	153.12	182.36	150.74	180.00	3/4
700/800	I, J, K, or L	2	24.64	12.62	18.25	67.00	38.60	41.90	55.57	11.58	9.90	153.12	182.36	150.74	180.00	3/4
840/960	I, J, K, or L	3	24.64	12.62	18.25	100.50	38.60	41.90	55.57	11.58	9.90	186.52	215.77	184.14	213.40	3/4

- ① For Right Hand Access Units - Location of drill locator dimples for field drilled gas connection entry holes - one side of unit and one on bottom.
- ② For Left Hand Access Units - Location of drill locator dimples for field drilled gas connection entry holes - one side of unit and one on bottom.
- ③ For Right Hand Access Units - Location of drill locator dimples for field drilled electrical connection, entry holes identical as side electrical connections.
- ④ For Left Hand Access Units - Location of drill locator dimples for field drilled electrical connection, entry holes identical as side electrical connections.
- ⑤ For Gravity Vented Models, the combustion air/vent cap is required so only dimensions B, C and D apply. For Power Vented Models, the power exhauster discharge cover and inlet louvers are included so only dimensions Q and R apply.
- ⑥ Applies to units with Digit 16 = L only.

**Figure 54.1
HCG/HCP Outdoor Cooling Package Unit Dimensions**



**Figure 54.2
HPG/HPP Outdoor Packaged Unit Dimensions**

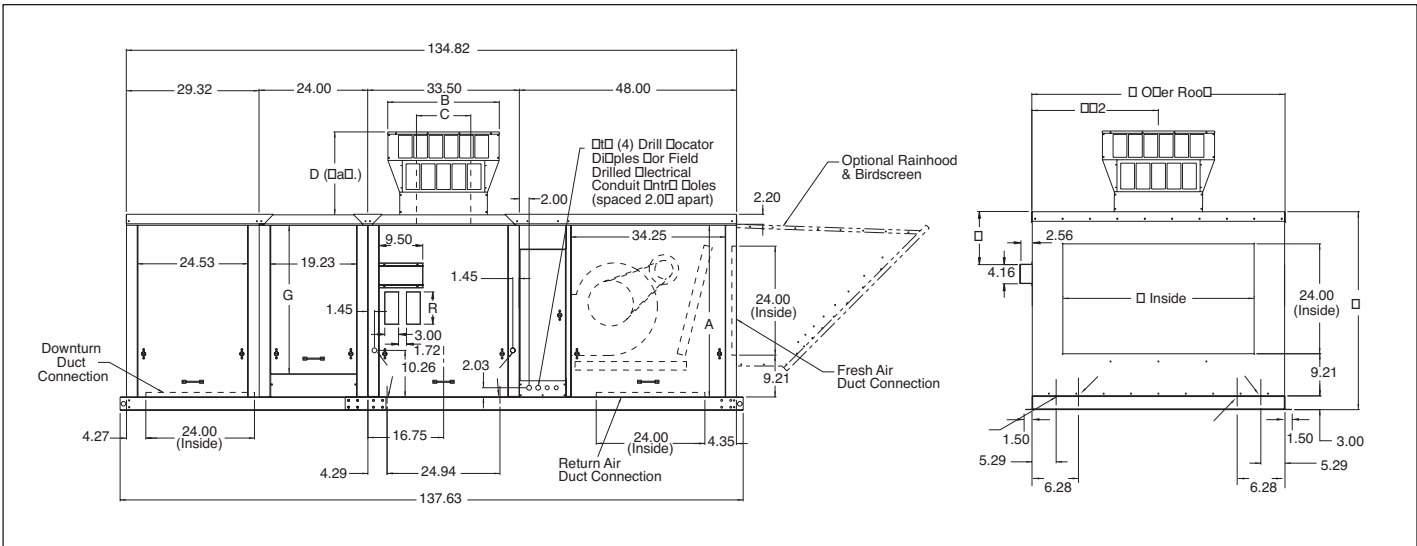

**Table 54.1
HCG/HCP/HPG/HPP Outdoor Unit Dimensions (All dimensions in inches)**

Model Size	Blower Type (Digit 16)	Dimensions											Gas Conn.	
		A	B ⑤	C ⑤	D ⑤	G	H	J	K	N	P	Q ⑤		R ⑤
75	All	33.75	19.22	8.62	14.07	28.75	18.00	25.50	20.02	39.23	32.06	10.75	7.00	1/2
100/125	All	33.75	19.22	8.62	14.07	28.75	21.00	25.50	20.02	39.23	34.56	10.75	7.00	1/2
150/175	All	33.75	19.22	8.62	14.07	28.75	24.00	25.50	23.99	39.23	38.82	10.75	7.00	1/2
200/225	All	37.75	19.22	8.62	14.07	32.75	27.00	30.50	23.99	43.23	40.94	11.58	9.90	1/2
250/300	E, F, G, or H	37.75	21.31	10.62	15.05	32.75	30.00	30.50	29.96	43.23	44.05	11.58	9.90	3/4
350/400	E, F, G, or H	37.75	24.64	12.62	18.25	32.75	42.00	30.50	41.90	43.23	55.57	11.58	9.90	3/4

- ① For Right Hand Access Units - Location of drill locator dimples for field drilled gas connection entry holes - one side of unit and one on bottom.
- ② For Left Hand Access Units - Location of drill locator dimples for field drilled gas connection entry holes - one side of unit and one on bottom.
- ③ For Right Hand Access Units - Location of drill locator dimples for field drilled electrical connection, entry holes identical as side electrical connections.
- ④ For Left Hand Access Units - Location of drill locator dimples for field drilled electrical connection, entry holes identical as side electrical connections.
- ⑤ For Gravity Vented Models, the combustion air/vent cap is required so only dimensions B, C and D apply. For Power Vented Models, the power exhauster discharge cover and inlet louvers are included so only dimensions Q and R apply.

Figure 55.1
HCG/HCP Outdoor Cooling Package Unit Dimensions with Blower Type I, J, or K

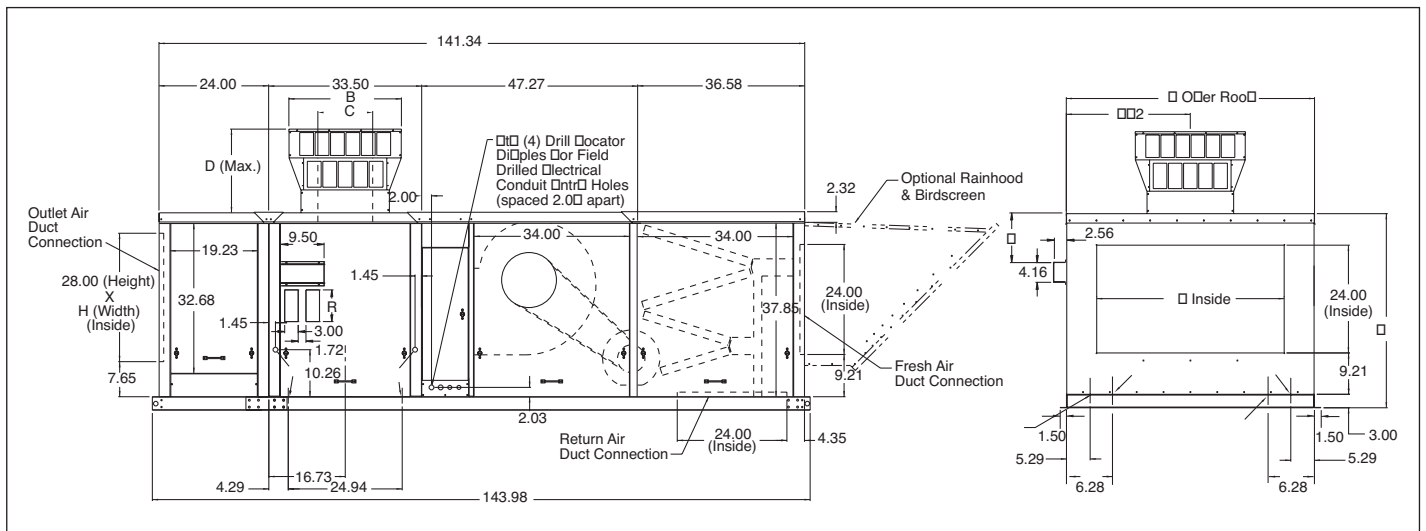

Figure 55.2
HPG/HPP Outdoor Packaged Unit Dimensions with Blower Type I, J or K

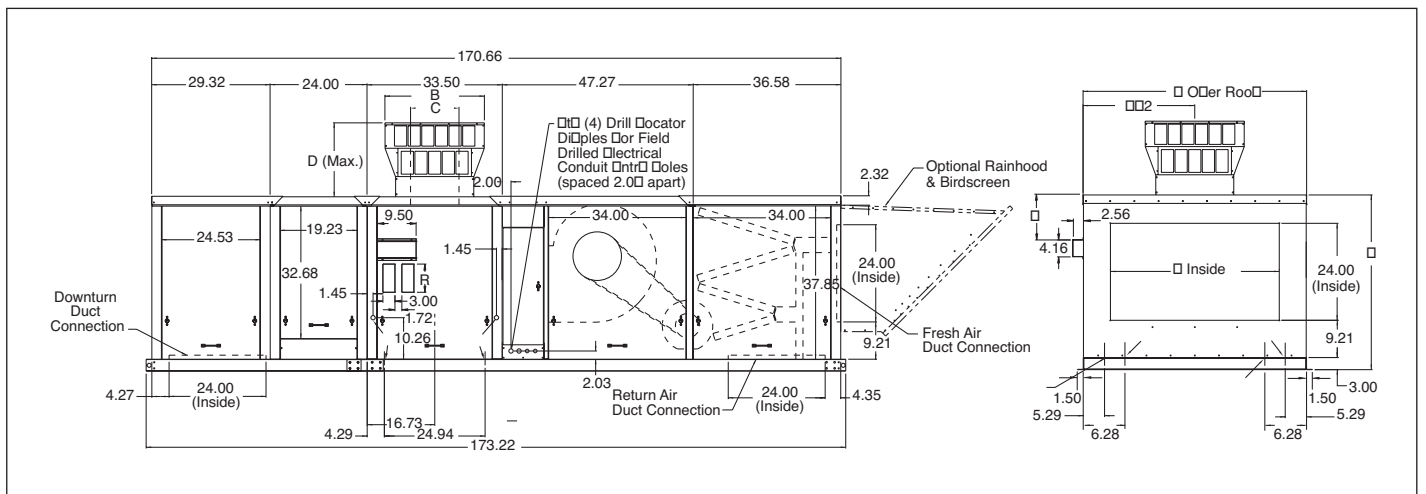

Table 55.1
HCG/HCP/HPG/HPP Outdoor Unit Dimensions (All dimensions in inches)

Model Size	Blower Type (Digit 16)	Dimensions										Gas Conn.
		B ⑤	C ⑤	D ⑤	F	H	K	N	P	Q ⑤	R ⑤	
250/300	I, J, or K	21.31	10.62	15.05	27.09	30.00	29.96	43.23	44.05	11.58	9.90	3/4
350/400	I, J, or K	24.64	12.62	18.25	38.60	42.00	41.90	43.23	55.07	11.58	9.90	3/4

- ① For Right Hand Access Units - Location of drill locator dimples for field drilled gas connection entry holes - one side of unit and one on bottom.
- ② For Left Hand Access Units - Location of drill locator dimples for field drilled gas connection entry holes - one side of unit and one on bottom.
- ③ For Right Hand Access Units - Location of drill locator dimples for field drilled electrical connection, entry holes identical as side electrical connections.
- ④ For Left Hand Access Units - Location of drill locator dimples for field drilled electrical connection, entry holes identical as side electrical connections.
- ⑤ For Gravity Vented Models, the combustion air/vent cap is required so only dimensions B, C and D apply. For Power Vented Models, the power exhauster discharge cover and inlet louvers are included so only dimensions Q and R apply.

Figure 56.1
Unit Base Dimensions

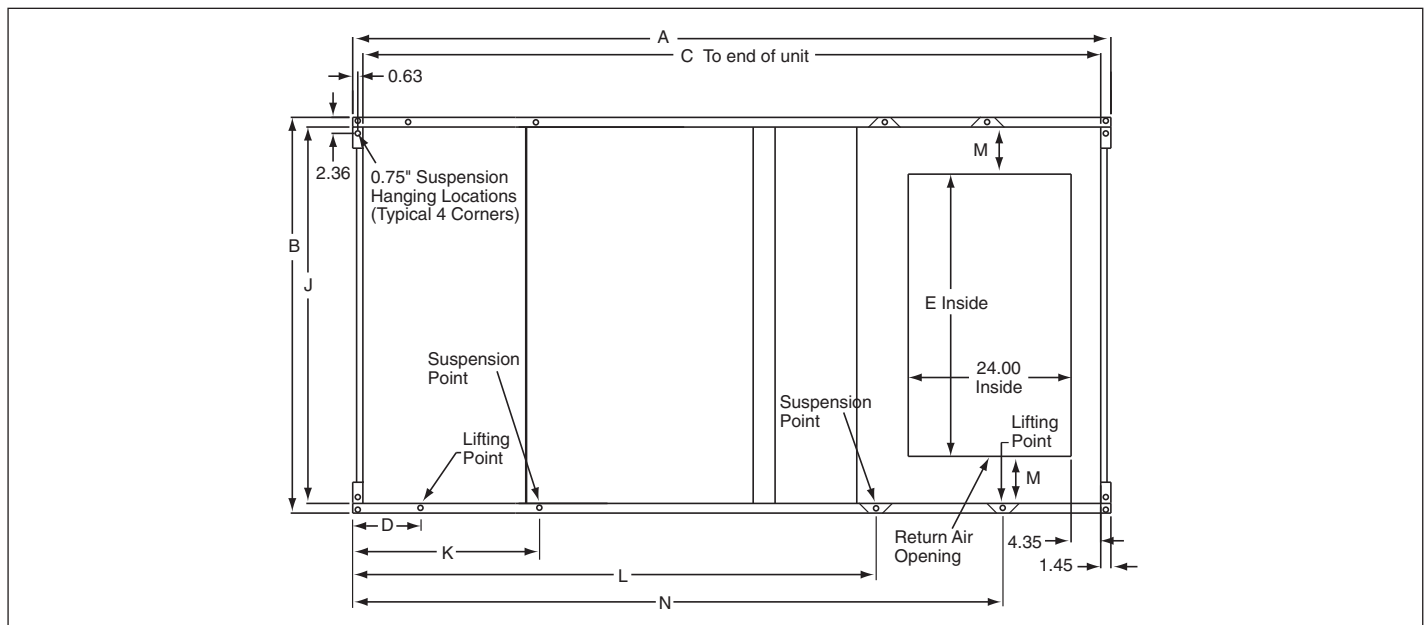

Table 56.1
Indoor Blower Package Unit Base Rail Dimensions (all dimensions in inches)

Model Size	Blower Type (Digit 16)	Dimensions															
		DBG						DBS						DBG & DBS			
		A	C	D	N	K	L	A	C	D	N	K	L	B	E	J	M
75	All	87.77	81.30	-	-	-	-	87.77	84.73	-	-	-	-	34.85	19.52	32.00	6.23
100/125	All	87.77	81.30	-	-	-	-	87.77	84.73	-	-	-	-	37.36	19.52	34.50	7.49
150/175	All	87.77	81.30	-	-	-	-	87.77	84.73	-	-	-	-	41.61	23.49	38.75	7.63
200/225	All	87.77	81.30	-	-	-	-	87.77	84.73	-	-	-	-	43.71	23.49	40.85	8.69
250/300	E,F,G, or H	87.77	81.30	-	-	-	-	87.77	84.73	-	-	-	-	46.75	29.46	43.89	7.21
250/300	I, J, or K	123.35	117.26	-	-	-	-	123.62	120.57	-	-	-	-	46.75	29.46	43.89	7.21
350/400	E,F,G, or H	87.77	81.30	-	-	-	-	87.77	84.73	-	-	-	-	58.27	41.40	55.41	7.00
350/400	I, J, or K	123.35	117.26	-	-	-	-	123.62	120.57	-	-	-	-	58.27	41.40	55.41	7.00
500/600	G, or H	120.90	111.68	34.12	89.14	34.12	-	128.77	119.54	42.00	97.03	42.00	-	46.75	29.46	43.89	7.21
500/600	I, J, K, or L	156.76	147.53	34.12	117.82	82.27	-	164.63	155.41	42.00	125.70	91.15	-	46.75	29.46	43.89	7.21
700/800	G, or H	120.90	111.68	34.12	89.14	34.12	-	128.77	119.54	42.00	97.03	42.00	-	58.27	41.40	55.41	7.00
700/800	I, J, K, or L	156.76	147.53	34.14	117.82	82.27	-	164.63	155.41	42.00	125.70	90.15	-	58.27	41.40	55.41	7.00
840/960	I, J, K, or L	185.99	176.75	30.31	147.06	63.36	147.06	205.77	196.52	48.58	166.84	82.94	166.84	58.27	41.40	55.41	7.00

Table 56.2
Indoor Cooling Package Unit Base Rail Dimensions (all dimensions in inches)

Model Size	Blower Type (Digit 16)	Dimensions									
		DCG		DCS		DCG & DCS					
		A	C	A	C	B	E	F	G	J	M
75	All	116.98	114.07	111.75	108.75	34.85	19.52	81.88	56.96	32.00	6.23
100/125	All	116.98	114.07	111.75	108.75	37.36	19.52	81.88	56.96	34.50	7.49
150/175	All	116.98	114.07	111.75	108.75	41.61	23.49	81.88	56.96	38.75	7.63
200/225	All	116.98	114.07	111.75	108.75	43.71	23.49	81.88	56.96	40.85	8.69
250/300	E, F, G, or H	116.98	114.07	111.75	108.75	46.75	29.46	81.88	56.96	43.89	7.21
250/300	I, J, or K	152.84	149.93	147.60	144.60	46.75	29.46	117.73	92.81	43.89	7.21
350/400	E, F, G, or H	116.98	114.07	111.75	108.75	58.27	41.40	81.88	56.96	55.41	7.00
350/400	I, J, or K	152.84	149.93	147.60	144.60	58.27	41.40	117.73	92.81	55.41	7.00

Figure 57.1 - Unit Base Dimensions

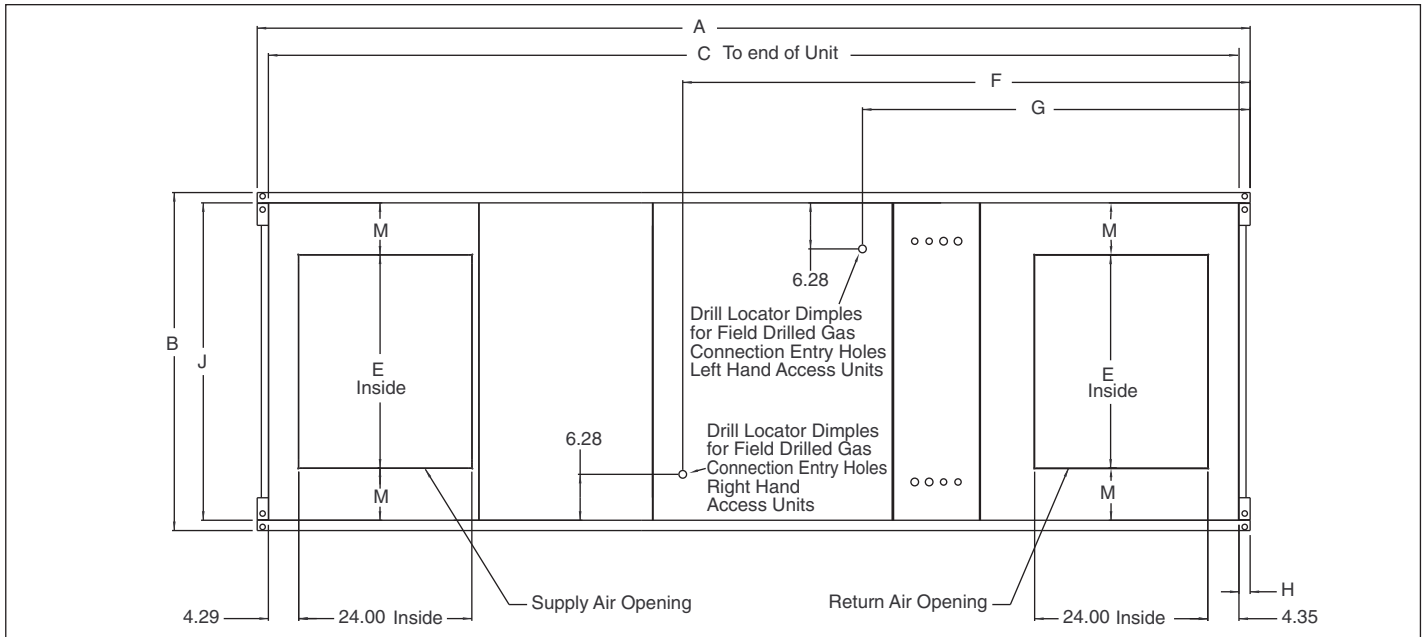

Table 57.1 - HBG/HBP & HDG/HDP Outdoor Unit Base Rail Dimensions (All dimensions in inches)

Model Size	Blower Type (Digit 16)	Dimensions										
		HBG/HBP		HDG/HDP		HBG/HBP/HDG/HDP						
		A	C	A	C	B	E	F ①	G ①	H	J	M
75	All	84.41	81.49	113.63	110.82	34.85	19.52	78.66	53.72	1.53	32.00	6.23
100/125	All	84.41	81.49	113.63	110.82	37.36	19.52	78.66	53.72	1.53	34.50	7.49
150/175	All	84.41	81.49	113.63	110.82	41.61	23.49	78.66	53.72	1.53	38.75	7.63
200/225	All	84.41	81.49	113.63	110.82	43.71	23.49	78.66	53.72	1.53	40.85	8.69
250/300	E,F,G, or H	84.41	81.49	113.63	110.82	46.75	29.46	78.66	53.72	1.53	43.89	7.21
250/300	I, J, or K	120.00	117.34	149.22	146.66	46.75	29.46	114.23	84.29	1.28	43.89	7.21
350/400	E,F,G, or H	84.41	81.49	113.63	110.82	58.27	41.40	78.66	53.72	1.53	55.41	7.00
350/400	I, J, or K	120.00	117.34	149.22	146.66	58.27	41.40	114.23	82.29	1.28	55.41	7.00
500/600	G or H	117.53	114.94	146.77	144.12	46.75	29.46	78.66	53.72	1.53	43.89	7.21
500/600	I, J, K, or L	153.12	150.74	182.36	180.00	46.75	29.46	114.23	82.29	1.28	43.89	7.21
700/800	G or H	117.53	114.94	146.77	144.12	58.27	41.40	78.66	53.72	1.53	55.41	7.00
700/800	I, J, K, or L	153.12	150.74	182.36	180.00	58.27	41.40	114.23	82.29	1.28	55.41	7.00
840/960	I, J, K, or L	186.52	184.14	215.77	213.40	58.27	41.40	114.23	82.29	1.28	55.41	7.00

Table 57.2 - HCG/HCP & HPG/HPP Outdoor Unit Base Rail Dimensions (All dimensions in inches)

Model Size	Blower Type (Digit 16)	Dimensions										
		HCG/HCP		HPG/HPP		HCG/HCP/HPG/HPP						
		A	C	A	C	B	E	F	G	H	J	M
75	All	108.39	105.49	137.63	134.82	34.85	19.52	78.66	53.72	1.53	32.00	6.23
100/125	All	108.39	105.49	137.63	134.82	37.36	19.52	78.66	53.72	1.53	34.50	7.49
150/175	All	108.39	105.49	137.63	134.82	41.61	23.49	78.66	53.72	1.53	38.75	7.63
200/225	All	108.39	105.49	137.63	134.82	43.71	23.49	78.66	53.72	1.53	40.85	8.69
250/300	E,F,G, or H	108.39	105.49	137.63	134.82	46.75	29.46	78.66	53.72	1.53	43.89	7.21
250/300	I, J, or K	143.98	141.34	173.22	170.66	46.75	29.46	114.23	82.29	1.28	43.89	7.21
350/400	E,F,G, or H	108.39	105.49	137.63	134.82	58.27	41.40	78.66	53.72	1.53	55.41	7.00
350/400	I, J, or K	143.98	141.34	173.22	170.66	58.27	41.40	114.23	82.29	1.28	55.41	7.00

① Gas connection for first furnace. For Models 500-800 add 33.5" for second furnace gas connection.
For Model 840-960 add 33.50" and 67.00" for second and third furnace gas connections.

Figure 58.1 - Roof Curb Dimensions

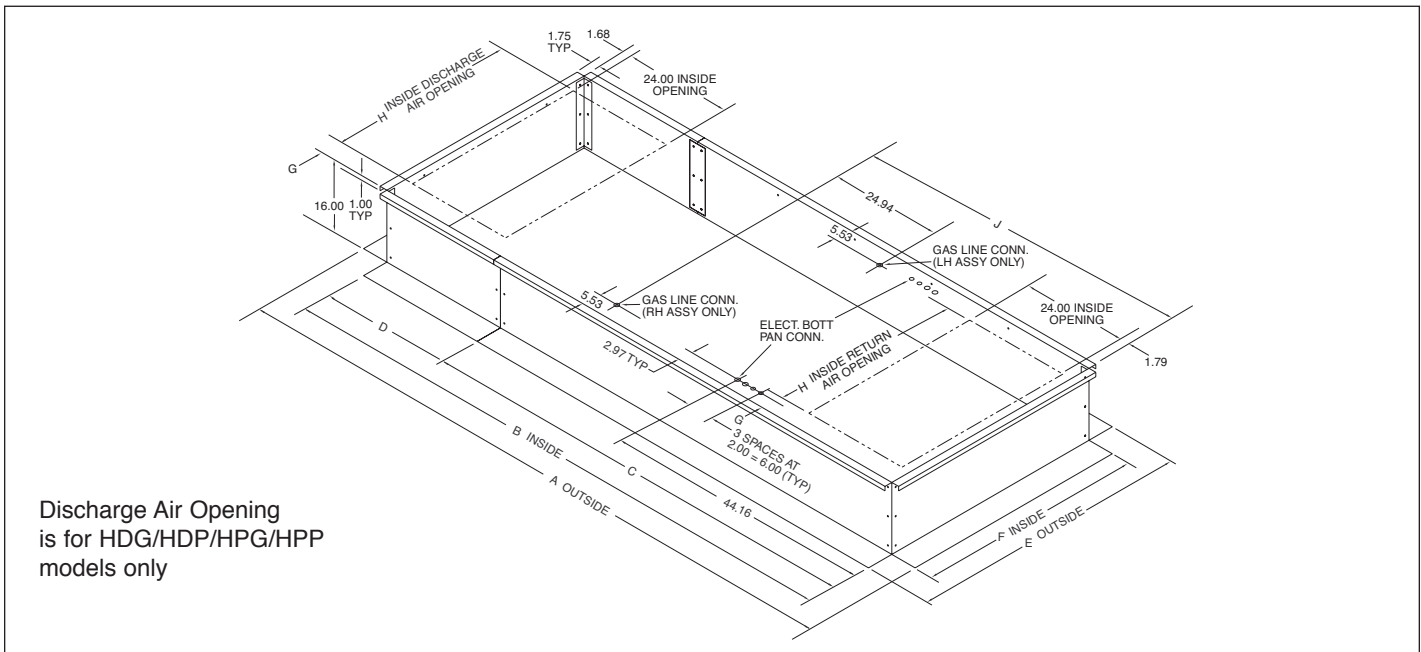

Table 58.1 - HBG/HBP & HDG/HDP Roof Curb Dimensions (All dimensions in inches)

Model Size	Blower Type (Digit 16)	Dimensions												
		HBG/HBP				HDG/HDP				HBG/HBP/HDG/HDP				
		A	B	C	D	A	B	C	D	E	F	G	H	J ①
75	All	88.77	76.77	-	-	117.98	105.98	-	-	39.33	27.33	3.97	19.52	74.84
100/125	All	88.77	76.77	-	-	117.98	105.98	-	-	41.84	29.84	5.22	19.52	74.84
150/175	All	88.77	76.77	-	-	117.98	105.98	-	-	46.18	34.18	5.41	23.49	74.84
200/225	All	88.77	76.77	-	-	117.98	105.98	-	-	48.22	36.22	6.43	23.49	74.84
250/300	E,F,G, or H	88.77	76.77	-	-	117.98	105.98	-	-	51.25	39.25	4.96	29.46	74.84
250/300	I, J, or K	124.61	112.61	-	-	153.83	141.63	105.98	35.85	51.25	39.25	4.96	29.46	110.41
350/400	E,F,G, or H	88.77	76.77	-	-	117.98	105.98	-	-	62.76	50.76	4.74	41.40	74.84
350/400	I, J, or K	124.61	112.61	-	-	153.83	141.63	105.98	35.85	62.76	50.76	4.74	41.40	110.41
500/600	G or H	121.89	109.89	-	-	151.10	139.10	105.98	33.12	51.25	39.25	4.96	29.46	74.84
500/600	I, J, K, or L	157.74	145.74	105.98	39.76	186.98	174.98	105.98	69.00	51.25	39.25	4.96	29.46	110.41
700/800	G or H	121.89	109.89	-	-	151.10	139.10	105.98	33.12	62.76	50.76	4.74	41.40	74.84
700/800	I, J, K, or L	157.74	145.74	105.98	39.76	186.98	174.98	105.98	69.00	62.76	50.76	4.74	41.40	110.41
840/960	I, J, K, or L	191.14	179.14	105.98	73.16	220.39	208.39	105.98	102.41	62.76	50.76	4.74	41.40	110.41

Table 58.2 - HCG/HCP & HPG/HPP Roof Curb Dimensions (All dimensions in inches)

Model Size	Blower Type (Digit 16)	Dimensions												
		HCG/HCP				HPG/HPP				HCG/HCP/HPG/HPP				
		A	B	C	D	A	B	C	D	E	F	G	H	J
75	All	112.74	100.74	-	-	141.98	129.98	100.74	29.24	39.33	27.33	3.97	19.52	74.84
100/125	All	112.74	100.74	-	-	141.98	129.98	100.74	29.24	41.84	29.84	5.22	19.52	74.84
150/175	All	112.74	100.74	-	-	141.98	129.98	100.74	29.24	46.18	34.18	5.41	23.49	74.84
200/225	All	112.74	100.74	-	-	141.98	129.98	100.74	29.24	48.22	36.22	6.43	23.49	74.84
250/300	E,F,G, or H	112.74	100.74	-	-	141.98	129.98	100.74	29.24	51.25	39.25	4.96	29.46	74.84
250/300	I, J, or K	148.59	136.59	105.98	30.61	177.83	165.83	105.98	59.85	51.25	39.25	4.96	29.46	110.41
350/400	E,F,G, or H	112.74	100.74	-	-	141.98	129.98	100.74	29.24	62.76	50.76	4.74	41.40	74.84
350/400	I, J, or K	148.59	136.59	105.98	30.61	177.83	165.83	105.98	59.85	62.76	50.76	4.74	41.40	110.41

① Gas connection for first furnace. For Models 500-800 add 33.5" for second furnace gas connection. For Model 840-960 add 33.50" and 67.00" for second and third furnace gas connections.

Figure 59.1
Rainhood and Birdscreen Dimensions (Outdoor Only)
(All dimensions in inches)

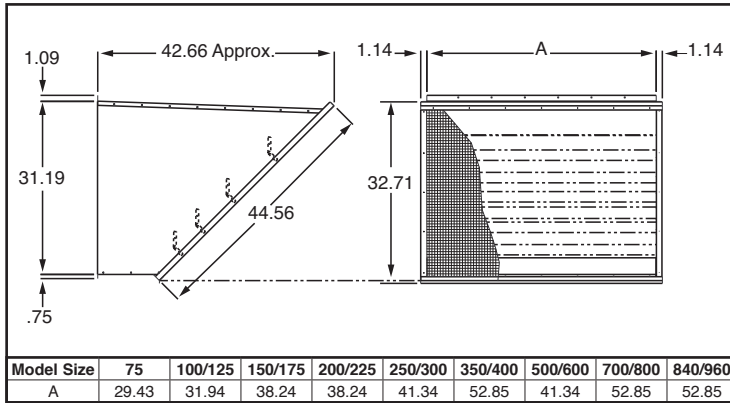

Custom Remote Monitoring Panels

Custom remote monitoring panels are available with any combination of light, switch, and/or thermostat panels. Specify the number of lights, switches, and/or thermostat as desired. All lights and switches must be tagged only with the listed tags.

Available Light Tags

- Heat On
- Blower On
- Blower On (High)
- Blower On (Low)
- Dirty Filters
- Cool On
- Evap On
- Smoke Alarm
- Power On

Available Switch Tags

- 2 Position Tags
- Day/Night
- Occupied/Unoccupied
- On/Off
- Heat/Off
- High/Low
- Summer/Winter
- Heat/Cool
- Auto/Off
- 3 Position Tags
- Heat/Vent/Cool
- Summer/Off/Winter
- Heat/Off/Vent
- On//Off/ Auto
- Cool//Off Auto

Thermostat Panel Style

<input type="checkbox"/> None
<input type="checkbox"/> Single Stage
<input type="checkbox"/> Two Stage
<input type="checkbox"/> Electronic Set Point Adjustor Maxitrol TD121

Figure 59.2
Remote Panel Dimensions (All dimensions in inches)

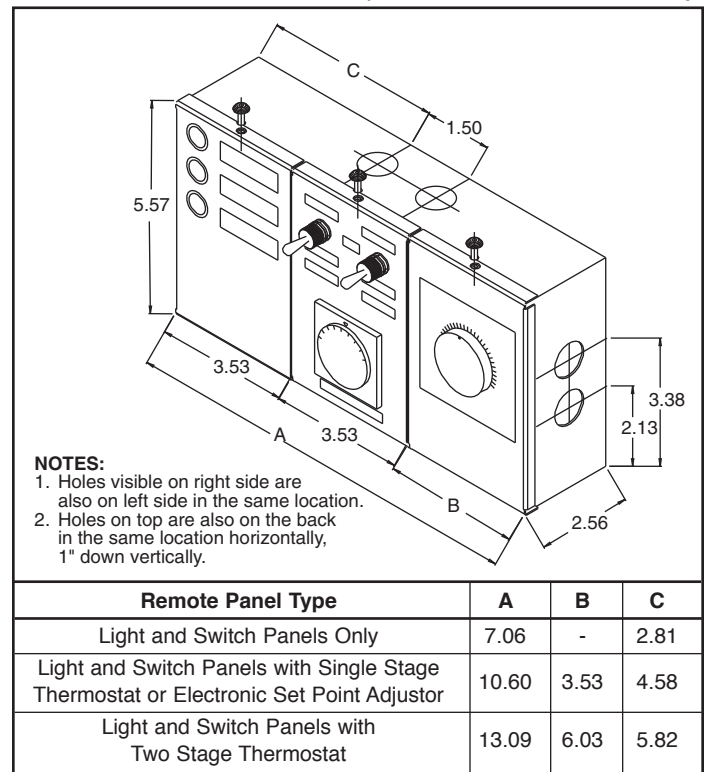

Table 60.1 - Base Unit Weights

Model Size	Blower Type (Digit 16)	Type of Unit													
		Blower Only					Blower + Cooling					Blower + Downturn		Blower + Cooling + Downturn	
		DBG	DBP	DBS	HBG (w/cap)	HBP	DCG	DCP	DCS	HCG (w/cap)	HCP	HDG (w/cap)	HDP	HPG (w/cap)	HPP
75	All	236	248	373	445	439	343	355	480	552	546	546	540	653	647
100/125	All	272	284	409	480	474	382	394	519	590	584	584	578	694	688
150/175	All	308	320	441	517	511	423	435	556	632	626	627	621	742	736
200/225	All	365	377	515	589	588	491	503	641	715	714	708	707	834	833
250/300	E,F,G, or H	396	408	568	637	626	526	538	698	767	756	758	747	888	877
250/300	I, J, or k	645	657	817	886	875	775	787	947	1016	1005	1007	996	1137	1126
350/400	E,F,G, or H	482	494	652	758	738	631	643	801	907	887	896	876	1045	1025
350/400	I, J, or k	763	775	933	957	1019	912	924	1082	1106	1168	1095	1157	1244	1306
500/600	G or H	577	589	843	981	959	n/a	n/a	n/a	n/a	n/a	1102	1080	n/a	n/a
500/600	I, J, k, or L	826	838	1092	1230	1208	n/a	n/a	n/a	n/a	n/a	1351	1329	n/a	n/a
700/800	G or H	733	745	981	1193	1153	n/a	n/a	n/a	n/a	n/a	1331	1291	n/a	n/a
700/800	I, J, k, or L	1014	1026	1262	1392	1352	n/a	n/a	n/a	n/a	n/a	1530	1490	n/a	n/a
840/960	I, J, k, or L	1265	1277	1591	1827	1767	n/a	n/a	n/a	n/a	n/a	1965	1905	n/a	n/a

Table 60.2 - Option Weights

Model Size	Blower Type (Digit 16)	Motor	Filters	Dampers		Insulation		Double Wall				Rainhood	Evap Cooler
				Fresh Air	Fresh & Return Air	DBG, DBP, DBS	DCG, DCP, DCS	DBG, DBP, DBS, HBG, HBP	DCG, DCP, DCS, HCG, HCP	HDG, HDP	HPG, HPP	"H" Series	"H" Series
75	All	See Motor Data	6	26	46	5	10	38	72	73	107	65	See Evap Cooler Data
100/125	All		6	26	46	5	10	38	72	73	107	67	
150/175	All		6	29	52	5	10	43	77	78	112	70	
200/225	All		6	29	52	7	12	46	85	86	125	72	
250/300	E,F,G, or H		8	33	60	7	12	46	87	88	129	83	
250/300	I, J, or k		15	33	60	14	19	93	134	135	176	83	
350/400	E,F,G, or H		12	38	70	7	12	53	101	102	150	90	
350/400	I, J, or k		17	38	70	14	19	96	144	145	193	90	
500/600	G or H		8	33	60	7	n/a	46	n/a	88	n/a	83	
500/600	I, J, k, or L		15	33	60	14	n/a	93	n/a	135	n/a	83	
700/800	G or H		12	38	70	7	n/a	53	n/a	102	n/a	90	
700/800	I, J, k, or L		17	38	70	14	n/a	96	n/a	145	n/a	90	
840/960	I, J, k, or L		17	38	70	14	n/a	96	n/a	145	n/a	90	

THIS PAGE INTENTIONALLY LEFT BLANK

Cooling Section Specifications for sizes 75-400

Models with a cooling section can be provided with either a factory installed direct expansion (DX) evaporator, a chilled fluid (for use with water, ethylene glycol, or propylene glycol fluids) coil, or the coil can be field supplied and installed by others. The cooling section is located downstream of the duct furnace heat exchanger in a blow-through configuration, preventing condensation on the heat exchanger in the cooling mode. Thus, a stainless steel heat exchanger is not required when a cooling section is used. (However, a stainless steel heat exchanger is still recommended when the combined entering/return air to the unit is below 40°F.)

The cooling section includes a full coverage, 3-way sloping 409 stainless steel drain pan to remove condensate from coil headers, thermal expansion valves, and refrigerant piping. Insulation is standard on outdoor units and optional on indoor units and double wall construction is optional on all units. The cabinet includes two doors, a removable upper door for service access to the coil once the plumbing has been installed and a lower door which includes a factory supplied 1" stubbed drain connection to the exterior of the cabinet. Field connections for coil inlet and outlet piping can be made through the cabinet corner post or back of the unit. The cooling section duct transition includes 1-1/2" flanges for fastening the sides of the coil. The bottom duct transition is angled to remove any condensation that may be entrained in the supply air stream.

For field supplied coils, do not exceed the factory installed coil dimensions. When obtaining the specifications from a coil manufacturer, it is important to obtain the pressure drop through the coil so that the proper motor horsepower can be selected.

Figure 62.1
Cooling Section

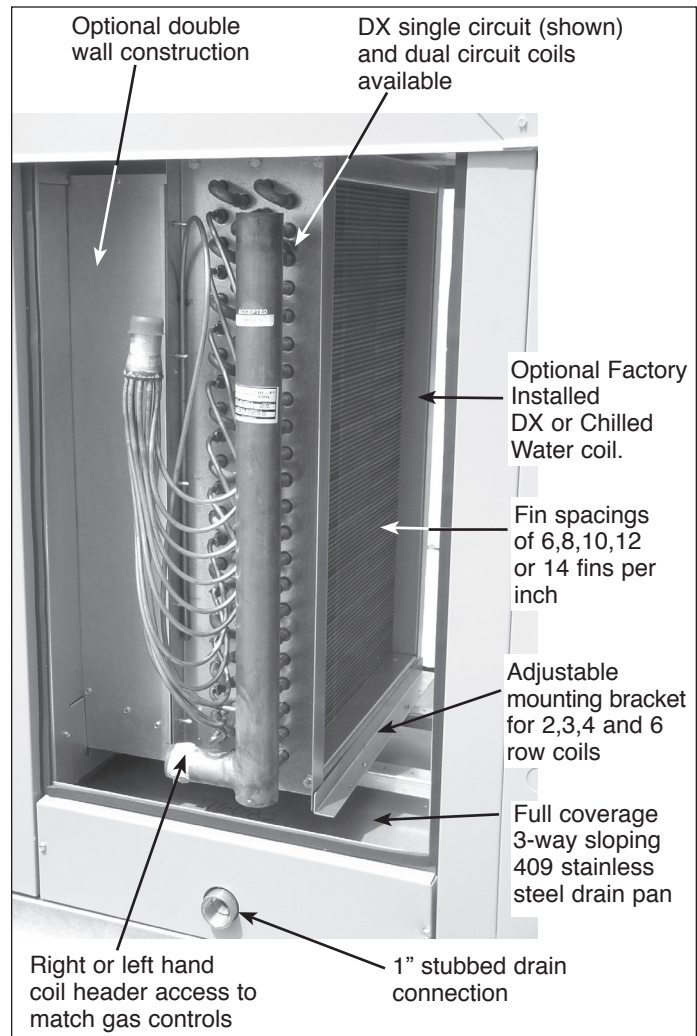

Table 62.1
Cooling Coil Performance Limits

Model Size	DX - Single Circuit		DX - Dual Circuit		Chilled Water		Min CFM (All Units)	Max. Cooling Tons ^② ^③	
	Max CFM ^①	Coil Area (Sq. Ft.)	Max CFM ^①	Coil Area (Sq. Ft.)	Max CFM ^①	Coil Area (Sq. Ft.)		DX Coils	Chilled Water Coils
75	1891	3.44	1707	3.10	1676	3.05	609 ^④	9.38	10.56
100	2206	4.01	2048	3.72	2011	3.66	741 ^⑤	11.43	12.62
125	2206	4.01	2048	3.72	2011	3.66	926	11.43	12.62
150	2521	4.58	2416	4.39	2372	4.31	1111	13.42	14.77
175	2521	4.58	2416	4.39	2372	4.31	1296	13.42	14.77
200	3352	6.09	3165	5.76	3214	5.84	1481	18.12	19.28
225	3352	6.09	3165	5.76	3214	5.84	1667	18.12	19.28
250	3724	6.77	3538	6.43	3592	6.53	1852	20.24	21.33
300	3724	6.77	3538	6.43	3592	6.53	2222	20.24	21.33
350	5214	9.48	4996	9.08	5073	9.22	2593	27.26	29.25
400	5214	9.48	4996	9.08	5073	9.22	2963	27.26	29.25

^① Based on 550 feet per minute (FPM) coil face velocity.

^② 1 Ton = 12,000 Btu/Hr

^③ Based on 95°F Entering Dry Bulb, 75° Entering Wet Bulb - Refer to page 65 for refrigerant conditions and page 67 for chilled water conditions.

^④ Model Size 75 CFM listed for Chilled Water - DX Single Circuit CFM minimum is 688 and DX Dual Circuit CFM min is 621.

^⑤ Model Size 100 CFM listed for Chilled Water - DX Single Circuit CFM minimum is 802 and DX Dual Circuit CFM min is 745.



Cooling Coil Selection

Modine Breeze™ AccuSpec selection software is the preferred method of cooling coil sizing and selection because of the variety of inlet air conditions and unit airflow. The following tables provide general performance of the cooling coil options available.

Unit Selection Information

Cooling coil selection requires the following inputs:

Cooling Coil Selection Inputs (All Coils)

- **Model Size** to determine cabinet dimensions.
- **Airflow** in Actual Cubic Feet Per Minute (ACFM) and Altitude. **Note:** For manual selection in performance tables, the ACFM needs to be converted to Standard Cubic Feet Per Minute (SCFM).
- **Entering Air Conditions** (Dry and Wet Bulb) to the coil. Units with both outside and return air require the mixed air temperature to be calculated - See below for Mixed Air Temperature Calculation. Refer to the ASHRAE Fundamentals Handbook for Cooling Climatic Design Information for outside air data.
- **Cooling capacity** required in MBH or Tons.

DX Cooling Additional Inputs

- **Refrigerant** is R410A. Consult factory for other refrigerants.
- **Evaporator circuiting** - Single Circuit (1-Stage Cooling) or Dual Circuit (2-Stage Cooling)
- **Suction Temperature** (°F)
- **Liquid Temperature** (°F)
- **Refrigerant Super Heat Temperature** (°F)

Chilled Water Additional Inputs

- **Fluid Type:** Water, Ethylene Glycol, or Propylene Glycol.
- **Mixture Percent:** For Glycol solutions, the percentage of the solution that is either ethylene or propylene (0-60%).
- **Entering Fluid Temperature** (°F)
- **Fluid Flow Rate** (GPM) or Leaving Fluid Temperature °F

MIXED AIR TEMPERATURE CALCULATION

The cooling coil capacity is based on the mixed air temperature seen by the cooling coil. When outside air and return air streams are mixed and then delivered to the cooling coil, the mixed air temperature must be calculated to determine the capacity.

Mixed Air Dry Bulb Formula

$$\frac{\text{Outside Air DB} \times \text{Percent Outside Air} + \text{Return Air DB} \times \text{Percent Return Air}}{\text{Mixed Air Dry Bulb}}$$

Mixed Air Dry Bulb Formula

$$\frac{\text{Outside Air Enthalpy} \times \text{Percent Outside Air} + \text{Return Air Enthalpy} \times \text{Percent Return Air}}{\text{Mixed Air Enthalpy}}$$

The Outside and Return Air Enthalpy is determined from Table 63.1 and the Mixed Air Enthalpy is converted back to a Mixed Air Wet Bulb using the same table.

Table 63.1

Enthalpy of Saturated Air for Various Wet Bulb Temp.

Wet Bulb Temp (°F)	Enthalpy (Btu/lb)	Wet Bulb Temp (°F)	Enthalpy (Btu/lb)	Wet Bulb Temp (°F)	Enthalpy (Btu/lb)
60	26.47	70	34.1	80	43.7
61	27.16	71	34.96	81	44.79
62	27.86	72	35.84	82	45.91
63	28.58	73	36.74	83	47.06
64	29.32	74	37.67	84	48.24
65	30.07	75	38.62	85	49.45
66	30.84	76	39.58		
67	31.63	77	40.58		
68	32.43	78	41.59		
69	33.25	79	42.63		

Example:

A heating & make-up air unit in Chicago is operating at 5000 CFM and is designed to deliver a maximum of 30% outside air. The outside design air conditions are 88°F DB / 73°F WB and the return air conditions are 75°F DB / 63°F WB.

The mixed dry bulb is calculation is

$$\begin{aligned} 88^\circ\text{F DB} \times .30 &= 26.4^\circ\text{F} \\ + 75^\circ\text{F DB} \times .70 &= + 52.5^\circ\text{F} \\ \hline \text{Mixed Air Dry Bulb} &= 78.9^\circ\text{F} \end{aligned}$$

To determine the mixed wet bulb the enthalpies must be determined. Using Table 63.1, 73°F = 36.75 Btu/lb and 63°F = 28.58 Btu/lb. Thus

$$\begin{aligned} 36.75^\circ\text{F Btu/lb} \times .30 &= 11.03 \\ + 28.58^\circ\text{F Btu/lb} \times .70 &= + 20.01 \\ \hline \text{Mixed Air Enthalpy} &= 31.04 \text{ Btu/lb} \end{aligned}$$

Using the Table 63.1, 31.04 Btu/lb = 66.3°F

STANDARD (SCFM) AIRFLOW CALCULATION

For elevations above 1500 feet, the selection of a cooling coil using a catalog method requires the conversion of the airflow from actual CFM (ACFM) to standard CFM (SCFM). The Modine Breeze™ AccuSpec selection software is the preferred method of cooling coil sizing and selection because the airflow correction is automatically calculated. Blower motor Hp must be selected using ACFM as blowers are constant volume devices. Cooling coil performance tables are based on SCFM (standard air density) and therefore the air volume must be converted to ACFM to determine the performance. The formula for conversion is:

$$\text{SCFM} = \text{ACFM} \times \text{Air Density Correction Factor}$$

where the Air Density factor can be found in Table 63.2 for various temperatures and elevations. The air temperature used would be the Mixed Air Dry Bulb temperature.

Table 63.2

Air Density Correction Factor

Air Temp (°F)	Altitude (Feet)						
	0	1500	2000	3000	4000	5000	6000
60	0.98	1.02	1.06	1.09	1.14	1.18	1.22
70	1.00	1.06	1.08	1.12	1.26	1.20	1.25
80	1.02	1.08	1.10	1.14	1.18	1.22	1.27
90	1.04	1.10	1.12	1.16	1.20	1.25	1.30
100	1.06	1.12	1.14	1.18	1.22	1.27	1.32

DX COOLING COIL PERFORMANCE DATA



Table 64.1
DX Single Circuit Cooling Coil Performance Data (R410A Refrigerant)

Capacity based on 80°F Entering Dry Bulb, 67°F Entering Wet Bulb, 45°F Sat. Suction, 8°F Superheat, 110°F Liquid. ①②③

Model Size	Air Flow SCFM④	Face Velocity FPM	Fin Spacing FPI ⑤	2-Row Coil ⑤						6-Row Coil ⑤					
				Cooling ⑦		Air P.D. "W.C.	Final Air Temp		Dry Weight lbs.	Cooling ⑦		Air P.D. "W.C.	Final Air Temp		Dry Weight lbs.
				Total MBH	Sensible MBH		DB °F	WB °F		Total MBH	Sensible MBH		DB °F	WB °F	
75	859	250	8	10.46	10.46	0.04	68.7	63.5	44	33.17	23.12	0.17	55.1	54.7	77
			14	14.91	14.91	0.07	63.9	61.9	48	39.33	26.18	0.26	51.8	51.8	92
	1375	400	8	14.11	14.11	0.08	70.5	64.1	44	47.5	34.08	0.36	57.1	56.2	77
			14	20.6	20.6	0.14	66.1	62.6	48	58.36	39.85	0.54	53.2	53.2	92
	1891	500	8	17.14	17.14	0.17	71.6	64.4	44	59.13	43.62	0.61	58.6	57.3	77
			14	25.5	25.5	0.22	68.5	63.1	48	73.21	51.72	0.9	54.7	54.6	92
100 & 125	1003	250	8	13.18	13.18	0.05	67.8	63.2	47	39.77	27.4	0.17	54.7	54.3	85
			14	18.98	18.12	0.07	63.3	61.4	52	47.47	31.22	0.26	51.2	51.2	102
	1604	400	8	17.61	17.61	0.09	69.8	63.8	47	57.57	40.6	0.36	56.6	55.7	85
			14	26.05	26.01	0.15	65	62.2	52	69.25	46.97	0.54	52.9	52.9	85
	2206	550	8	21.34	21.34	0.14	71	64.2	47	70.64	51.53	0.61	58.4	57	85
			14	32.05	32.05	0.23	66.5	62.8	52	87.18	61.01	0.9	54.4	54.3	102
150 & 175	1146	250	8	16.12	15.45	0.05	67.5	62.9	50	47.54	32.16	0.17	54	53.6	93
			14	23.32	21.26	0.08	62.8	60.9	56	55.61	36.27	0.26	50.7	50.7	112
	1833	400	8	21.41	21.28	0.1	69.3	63.6	50	66.87	46.8	0.36	56.4	55.4	93
			14	31.98	30.47	0.15	64.6	61.9	56	80.33	54.18	0.54	52.6	52.6	112
	2521	550	8	25.82	25.82	0.15	70.5	64.1	50	82.25	59.48	0.61	58.2	56.8	93
			14	39.13	38.51	0.25	65.9	62.5	56	101.19	70.4	0.9	54.1	54.1	112
200 & 225	1523	250	8	22.81	21	0.05	67.2	62.6	61	64.74	43.4	0.17	53.6	53.2	116
			14	33.04	28.97	0.08	62.4	60.5	69	74.65	48.53	0.26	50.5	50.5	141
	2438	400	8	30.17	28.87	0.1	69	63.4	61	90.3	62.77	0.36	56.2	55.2	116
			14	45.14	41.42	0.17	64.3	61.5	69	108.03	72.55	0.54	52.4	52.4	141
	3352	550	8	36.2	35.57	0.17	70.2	63.9	61	110.9	79.64	0.61	58	56.7	116
			14	55.08	52.25	0.25	65.6	62.2	69	136.09	94.21	0.9	54	53.9	141
250 & 300	1862	275	8	29.93	25.95	0.06	67.1	62.3	64	78.81	52.75	0.19	53.8	53.3	125
			14	43.51	36.2	0.09	62	60	74	91.15	59.24	0.3	50.5	50.5	153
	2708	400	8	37.18	33.26	0.11	68.6	63	64	102.36	70.58	0.36	55.9	55	125
			14	55.52	47.87	0.17	63.6	60.9	74	122.19	81.52	0.54	52.1	52.1	153
	3724	550	8	44.35	40.85	0.19	69.8	63.6	64	126.07	89.55	0.61	57.7	56.4	125
			14	67.26	60.11	0.28	65.1	61.7	74	154.06	105.83	0.9	53.7	53.7	153
350 & 400	2607	275	8	49.23	38.84	0.06	66.2	61.4	78	118.26	77.11	0.19	52.6	52.1	161
			14	69.63	53.83	0.1	60.9	58.9	91	134.54	86.01	0.3	49.5	49.5	200
	3792	400	8	61.08	49.63	0.12	67.9	62.3	78	154.48	103.28	0.36	54.8	53.9	161
			14	86.12	69.99	0.18	62.9	60.2	91	181.44	118.51	0.54	51.1	51.1	200
	5214	550	8	71.85	60.43	0.2	69.3	63	78	189.5	130.47	0.61	56.8	55.5	161
			14	101.63	86.76	0.3	64.6	61.2	91	228.51	153.47	0.9	52.7	52.7	200

① Refer to the Breeze™ AccuSpec selection software for additional coil selections and performance at other conditions.
 ② Coils are rated in compliance with ARI 410
 ③ Coils Types Available: Single Circuit (Performance data shown above) and Dual Circuit Interlaced (Refer to Breeze AccuSpec for performance data).
 ④ For Dual Circuit Coils, refer to page 62 for maximum CFM
 ⑤ Coil Rows Available: 2, 3, 4, and 6
 ⑥ Fin Spacings Available: 8, 10, 12, and 14
 ⑦ 1 Ton = 12 MBH



DX COOLING COIL PERFORMANCE DATA

Table 65.1

DX Single Circuit Cooling Coil Performance Data (R410A Refrigerant)

Capacity based on 95°F Entering Dry Bulb, 75°F Entering Wet Bulb, 45°F Sat. Suction, 8°F Superheat, 110°F Liquid. ①②③

Model Size	Air Flow SCFM ④	Face Velocity FPM	Fin Spacing FPI ⑥	2-Row Coil ⑤						6-Row Coil ⑤					
				Cooling ⑦		Air P.D. "W.C.	Final Air Temp		Dry Weight lbs.	Cooling ⑦		Air P.D. "W.C.	Final Air Temp		Dry Weight lbs.
				Total MBH	Sensible MBH		DB °F	WB °F		Total MBH	Sensible MBH		DB °F	WB °F	
75	859	250	8	22.11	18.02	0.06	75.6	68.5	44	57.65	35.95	0.17	56.2	55.6	77
			14	31.8	24.84	0.09	68.2	65.3	48	65.9	40.12	0.26	51.8	51.8	92
	1375	400	8	28.94	24.68	0.12	78.4	69.7	44	81.03	52.16	0.36	59.9	58.5	77
			14	43.12	35.37	0.18	71.2	66.9	48	96.46	60.32	0.54	54.4	54.4	92
	1891	500	8	34.3	30.3	0.2	80.2	70.5	44	100.12	66.33	0.61	62.5	60.5	77
			14	52.27	44.53	0.28	73.2	68	48	122.58	78.61	0.9	56.5	56.4	92
100 & 125	1003	250	8	28.02	21.69	0.06	75	67.9	47	68.15	42.31	0.17	55.9	55.3	85
			14	39.84	29.87	0.09	67.4	64.5	52	77.48	47.08	0.26	51.5	51.5	102
	1604	400	8	36.65	29.62	0.12	77.9	69.3	47	95.87	61.34	0.36	59.6	58.2	85
			14	54.11	42.43	0.18	70.5	66.3	52	113.79	70.87	0.54	54.1	54.1	102
	2206	550	8	43.47	36.33	0.2	79.8	70.1	47	119.01	78.15	0.61	62.2	60.1	85
			14	63.89	52.81	0.3	72.8	67.6	52	144.64	92.32	0.9	56.2	56.2	102
150 & 175	1146	250	8	33.88	25.34	0.06	74.5	67.4	50	78.64	48.65	0.17	55.7	55.1	93
			14	47.96	34.9	0.09	66.8	63.9	56	89.3	54.12	0.26	51.3	51.3	112
	1833	400	8	44.66	34.65	0.12	77.5	68.9	50	110.72	70.55	0.36	59.4	58	93
			14	63.96	49.15	0.18	70.2	65.9	56	131.05	81.39	0.54	53.9	53.9	112
	2521	550	8	52.94	42.45	0.2	79.4	69.8	50	137.04	89.67	0.61	62.1	60	93
			14	75.3	61.05	0.3	72.6	67.4	56	166.49	105.97	0.9	56.1	56	112
200 & 225	1523	250	8	47.3	34.37	0.06	74.1	67	61	105.31	64.96	0.17	55.5	54.9	116
			14	66.62	47.35	0.09	66.2	63.3	69	119.49	72.28	0.26	51.1	51.1	141
	2438	400	8	62.01	46.85	0.12	77.2	68.6	61	148.38	94.27	0.36	59.2	57.8	116
			14	87.23	66.05	0.18	69.9	65.7	69	175.15	108.58	0.54	53.8	53.8	141
	3352	550	8	77.28	57.12	0.2	79.2	69.6	61	183.82	119.83	0.61	61.9	59.8	116
			14	102.76	81.95	0.3	72.4	67.1	69	222.22	141.23	0.9	56	55.9	141
250 & 300	1862	275	8	59.86	42.01	0.06	74.1	66.7	64	127.09	78.52	0.19	56	55.2	125
			14	82.5	57.71	0.1	66.3	63.2	74	145.34	88	0.3	51.2	51.2	153
	2708	400	8	73.22	53.32	0.12	76.8	68.1	64	166.89	105.47	0.36	58.9	57.6	125
			14	101.97	74.97	0.18	69.4	65.2	74	196.32	121.35	0.54	53.5	53.5	153
	3724	550	8	84.95	64.66	0.2	78.9	69.3	64	205.58	133.58	0.61	61.8	59.7	125
			14	120.95	93.12	0.3	71.8	66.6	74	248.81	157.69	0.9	55.8	55.7	153
350 & 400	2607	275	8	88.86	60.38	0.06	73.6	66.2	78	186.77	113.46	0.19	54.7	54	161
			14	121.91	82.94	0.1	65.5	62.4	91	209.42	125.77	0.3	50.3	50.3	200
	3792	400	8	108.28	76.37	0.12	76.4	67.7	78	242.62	151.11	0.36	58.1	56.7	161
			14	151.51	107.76	0.18	68.7	64.5	91	281.08	172.47	0.54	52.9	52.9	200
	5214	550	8	126.08	92.54	0.2	78.6	68.9	78	297.74	190.6	0.61	61.2	59.1	161
			14	179.36	133.46	0.3	71.3	66.1	91	353.49	222.79	0.9	55.4	55.4	200

① Refer to the Breeze™ AccuSpec selection software for additional coil selections and performance at other conditions.
 ② Coils are rated in compliance with ARI 410
 ③ Coils Types Available: Single Circuit (Performance data shown above) and Dual Circuit Interlaced (Refer to Breeze AccuSpec for performance data).
 ④ For Dual Circuit Coils, refer to page 62 for maximum CFM
 ⑤ Coil Rows Available: 2, 3, 4, and 6
 ⑥ Fin Spacings Available: 8, 10, 12, and 14
 ⑦ 1 Ton = 12 MBH

CHILLED WATER COOLING COIL PERFORMANCE DATA



Table 66.1
Chilled Water Cooling Coil Performance Data

Capacity based on 80°F Entering Dry Bulb, 67°F Entering Wet Bulb, 45°F Entering Water Temp, 70 GPM. ①②③

Model Size	Air Flow SCFM	Face Velocity FPM	Fin Spacing FPI ⑤	4-Row Coil ④							6-Row Coil ④						
				Cooling ⑥		Air P.D. ③	Water P.D. ③	Final Air		Dry Wt lbs	Cooling ⑥		Dry P.D.	Water P.D.	Final Air		Dry Wt lbs
				Total	Sen			DB	WB		Total	Sen			DB	WB	
				MBH	MBH	"W.C.	Ft H ₂ O	°F	°F	MBH	MBH	"W.C.	Ft H ₂ O	°F	°F	MBH	MBH
75	762	250	6	31.0	19.8	0.09	13.9	56.3	53.8	59	37.8	23.8	0.14	16.0	51.5	50.4	76
			10	38.1	24.1	0.15	13.9	51.1	50.2	65	43.4	27.0	0.23	16.0	47.6	47.3	84
			14	41.2	25.9	0.21	13.9	48.9	48.5	70	45.4	28.1	0.31	16.0	46.3	46.2	93
	1219	400	6	41.6	27.4	0.21	13.9	59.5	56.2	59	52.7	34.0	0.31	16.0	54.5	52.8	76
			10	52.7	34.3	0.32	13.9	54.2	52.8	65	62.9	40.0	0.49	16.0	50.0	49.6	84
			14	58.4	37.8	0.44	13.9	51.7	51.0	70	67.5	42.5	0.65	16.0	48.1	48.0	93
	1676	550	6	50.0	33.6	0.36	13.9	61.6	57.7	59	64.2	42.7	0.55	16.0	56.7	54.7	76
			10	63.7	43.0	0.54	13.9	56.6	54.8	65	78.5	51.2	0.82	16.0	52.1	51.4	84
			14	71.9	47.9	0.71	13.9	53.9	52.9	70	85.8	55.1	1.07	16.0	49.9	49.7	93
100 & 125	914	250	6	37.2	23.7	0.09	14.3	56.3	53.8	66	45.2	28.5	0.14	16.6	51.5	50.4	85
			10	45.6	28.8	0.15	14.3	51.2	50.2	72	51.9	32.3	0.23	16.6	47.7	47.4	95
			14	49.4	31.0	0.21	14.3	48.9	48.5	79	54.3	33.7	0.31	16.6	46.3	46.3	105
	1463	400	6	50.0	32.8	0.21	14.3	59.5	56.2	66	62.8	40.6	0.31	16.6	54.6	52.9	85
			10	62.8	41.1	0.32	14.3	54.3	52.9	72	75.3	47.9	0.49	16.6	50.1	49.6	95
			14	69.9	45.2	0.44	14.3	51.8	51.1	79	80.6	50.8	0.65	16.6	48.2	48.1	105
	2011	550	6	59.4	40.3	0.36	14.3	61.7	57.8	66	77.0	51.0	0.55	16.6	56.8	54.7	85
			10	76.1	51.4	0.54	14.2	56.7	54.8	72	93.9	61.2	0.82	16.5	52.2	51.5	95
			14	85.7	57.3	0.71	14.2	54.0	53.0	79	102.4	65.9	1.07	16.5	50.1	49.8	105
150 & 175	1186	275	6	46.5	29.8	0.11	14.7	57.0	54.3	72	57.0	36.1	0.16	17.2	52.2	50.9	95
			10	57.5	36.5	0.18	14.7	51.8	50.8	80	66.1	41.3	0.26	17.2	48.1	47.8	107
			14	62.6	39.5	0.24	14.6	49.5	49.1	88	69.6	43.2	0.36	17.2	46.7	46.6	119
	1725	400	6	58.4	38.5	0.21	14.7	59.6	56.3	72	74.0	47.8	0.31	17.1	54.7	52.9	95
			10	73.8	48.2	0.32	14.6	54.4	53.0	80	88.3	56.3	0.49	17.1	50.2	49.7	107
			14	82.0	53.1	0.44	14.6	51.9	51.2	88	94.9	59.7	0.65	17.1	48.3	48.2	119
	2372	550	6	70.0	47.5	0.36	14.6	61.7	57.8	72	90.1	59.9	0.55	17.1	56.9	54.8	95
			10	89.4	60.5	0.54	14.6	56.7	54.9	80	109.7	71.9	0.82	17.1	52.3	51.6	107
			14	100.4	67.3	0.71	14.6	54.1	53.1	88	120.1	77.4	1.07	17.1	50.2	49.9	119
200 & 225	1607	275	6	61.8	39.9	0.11	12.7	57.3	54.6	92	79.2	48.4	0.16	14.5	52.5	51.2	121
			10	76.2	48.7	0.18	12.7	52.3	51.2	103	88.2	55.3	0.26	14.5	48.5	48.2	137
			14	83.1	52.7	0.24	12.7	50.0	49.5	113	93.1	58.0	0.36	14.5	47.0	46.9	154
	2338	400	6	77.3	51.3	0.21	12.7	59.9	56.5	92	97.7	63.8	0.31	14.5	55.1	53.4	121
			10	97.0	64.1	0.32	12.7	54.9	53.5	103	116.5	74.9	0.49	14.5	50.7	50.2	137
			14	107.5	70.4	0.44	12.7	52.5	51.8	113	125.5	79.6	0.65	14.5	48.9	48.7	154
	3214	550	6	91.8	63.0	0.36	12.7	62.1	58.1	92	118.3	79.5	0.55	14.5	57.4	55.2	121
			10	116.4	79.7	0.54	12.7	57.3	55.4	103	143.8	95.1	0.82	14.5	52.9	52.2	137
			14	130.5	88.7	0.71	12.7	54.8	53.8	113	157.1	102.3	1.07	14.5	50.9	50.6	154
250 & 300	1861	285	6	70.5	45.6	0.12	12.9	57.6	54.8	99	86.9	55.3	0.17	14.9	52.8	51.5	131
			10	86.9	55.8	0.19	12.9	52.6	51.5	111	101.1	63.6	0.28	14.9	48.8	48.4	149
			14	94.7	60.5	0.26	12.9	50.3	49.8	123	106.9	66.7	0.39	14.9	47.3	47.1	167
	2613	400	6	86.0	57.3	0.21	12.9	60.0	56.6	99	108.8	71.0	0.31	14.9	55.2	53.4	131
			10	107.6	71.5	0.32	12.9	55.0	53.6	111	129.8	83.5	0.49	14.9	50.8	50.3	149
			14	119.4	78.4	0.44	12.9	52.6	51.9	123	139.9	88.7	0.65	14.8	49.0	48.7	167
	3592	550	6	101.5	70.2	0.36	12.9	62.1	58.2	99	131.2	88.5	0.55	14.9	57.5	55.3	131
			10	129.0	88.9	0.54	12.9	57.4	55.5	111	159.7	105.9	0.82	14.8	53.0	52.3	149
			14	144.8	98.8	0.71	12.9	54.9	53.9	123	174.1	113.8	1.07	14.8	51.0	50.8	167
350 & 400	2629	285	6	98.4	63.9	0.12	13.8	57.8	55.0	126	121.0	77.6	0.17	16.2	53.0	51.8	170
			10	120.9	78.0	0.19	13.8	52.9	51.8	143	141.1	89.1	0.28	16.2	49.0	48.7	196
			14	132.4	84.7	0.26	13.8	50.6	50.0	160	149.6	93.6	0.39	16.2	47.5	47.3	221
	3690	400	6	119.2	80.0	0.21	13.8	60.2	56.8	126	151.0	99.2	0.31	16.2	55.4	53.7	170
			10	149.3	99.6	0.32	13.8	55.3	53.8	143	179.8	116.2	0.49	16.2	51.2	50.7	196
			14	165.6	109.5	0.44	13.8	52.9	52.2	160	193.7	123.9	0.65	16.2	49.3	49.2	221
	5073	550	6	140.9	97.9	0.36	13.8	62.4	58.4	126	180.7	123.1	0.55	16.2	57.8	55.6	170
			10	177.5	123.8	0.54	13.8	57.7	55.8	143	219.0	147.0	0.82	16.1	53.5	52.8	196
			14	198.6	136.8	0.71	13.8	55.3	54.3	160	239.6	158.0	1.07	16.1	51.5	51.3	221

① Refer to the Breeze™ AccuSpec selection software for additional coil selections and performance at other conditions.

② Coils are rated in compliance with ARI 410

③ Coil Circuiting Available: 1/4, 1/2, 3/4 (Performance data shown above), and Full Circuiting and is calculated by the Breeze™ AccuSpec program.

④ Coil Rows Available: 4 and 6

⑤ Fin Spacings Available: 6, 8, 10, 12, and 14

⑥ 1 Ton = 12 MBH



CHILLED WATER COOLING COIL PERFORMANCE DATA

Table 67.1

Chilled Water Cooling Coil Performance Data

Capacity based on 95°F Entering Dry Bulb, 75°F Entering Wet Bulb, 45°F Entering Water Temp, 70 GPM. ①②③

Model Size	Air Flow SCFM	Face Velocity FPM	Fin Spacing FPI ⑤	4-Row Coil ④							6-Row Coil ④						
				Cooling ⑥		Air P.D.	Water P.D. ③	Final Air		Dry Wt lbs	Cooling ⑥		Air P.D.	Water P.D. ③	Final Air		Dry Wt lbs
				Total MBH	Sen MBH			°F	°F		Total MBH	Sen MBH			°F	°F	
75	762	250	6	46.0	28.0	0.09	13.9	61.5	57.8	59	56.1	33.7	0.14	16.0	54.6	53.0	76
			10	56.6	34.0	0.15	13.9	54.2	52.8	65	64.5	38.3	0.23	16.0	49.0	48.7	84
			14	61.3	36.7	0.21	13.9	51.0	50.4	70	67.6	39.9	0.31	16.0	47.1	47.0	93
	1219	400	6	61.5	38.6	0.21	13.9	66.0	61.1	59	77.9	48.0	0.31	16.0	59.0	56.6	76
			10	77.6	48.4	0.32	13.9	58.7	56.7	65	93.3	56.5	0.49	16.0	52.6	51.9	84
			14	86.4	53.3	0.44	13.9	55.0	54.1	70	100.1	60.1	0.65	16.0	49.9	49.8	93
	1676	550	6	73.2	47.5	0.36	13.9	69.1	63.2	59	95.1	60.2	0.55	16.0	62.2	59.0	76
			10	93.6	60.5	0.54	13.9	62.0	59.3	65	116.0	72.1	0.82	16.0	54.7	54.7	84
			14	105.7	67.4	0.71	13.9	58.2	56.9	70	126.7	77.7	1.07	16.0	52.6	52.3	93
100 & 125	914	250	6	55.2	33.5	0.09	14.3	61.5	57.8	66	67.2	40.4	0.14	16.6	54.6	53.1	85
			10	67.7	40.7	0.15	14.3	54.3	52.9	72	77.2	45.8	0.23	16.6	49.2	48.8	95
			14	73.3	43.9	0.21	14.2	51.0	50.5	79	80.9	47.8	0.31	16.5	47.2	47.1	105
	1463	400	6	73.5	46.2	0.21	14.2	66.1	61.2	66	93.2	57.5	0.31	16.5	59.1	56.7	85
			10	92.9	57.9	0.32	14.2	58.8	56.7	72	111.1	67.6	0.49	16.5	52.8	52.1	95
			14	103.2	63.7	0.44	14.2	55.2	54.2	79	119.8	71.9	0.65	16.5	50.1	49.8	105
	2011	550	6	87.4	56.8	0.36	14.2	69.2	63.3	66	113.2	71.8	0.55	16.5	62.3	59.2	85
			10	111.9	72.3	0.54	14.2	62.1	59.4	72	138.4	86.3	0.82	16.5	55.8	54.8	95
			14	126.1	80.6	0.71	14.2	58.4	57.0	79	151.4	92.9	1.07	16.5	52.7	52.4	105
150 & 175	1186	275	6	69.0	42.2	0.11	14.6	62.4	58.6	72	84.8	51.2	0.16	17.1	55.5	53.9	95
			10	85.2	51.6	0.18	14.6	55.2	53.7	80	98.4	58.6	0.26	17.1	49.8	49.4	107
			14	92.9	55.9	0.24	14.6	51.9	51.3	88	103.5	61.3	0.36	17.1	47.8	47.6	119
	1725	400	6	86.3	54.4	0.21	14.6	66.2	61.2	72	109.6	67.6	0.31	17.1	59.2	56.7	95
			10	108.9	68.1	0.32	14.6	58.9	56.9	80	130.8	79.4	0.49	17.1	52.9	52.2	107
			14	121.0	74.9	0.44	14.6	55.3	54.3	88	140.7	84.5	0.65	17.1	50.2	50.0	119
	2372	550	6	102.6	66.8	0.36	14.6	69.3	63.4	72	133.1	84.5	0.55	17.1	62.4	59.3	95
			10	131.1	85.0	0.54	14.6	62.3	59.5	80	162.4	101.3	0.82	17.1	56.0	54.9	107
			14	147.8	94.7	0.71	14.6	58.5	57.1	88	177.2	109.1	1.07	17.0	52.9	52.6	119
200 & 225	1607	275	6	91.5	56.3	0.11	12.7	63.0	59.0	92	112.8	68.4	0.16	14.5	56.1	54.3	121
			10	112.5	68.8	0.18	12.7	55.8	54.4	103	130.8	78.3	0.26	14.5	50.4	50.0	137
			14	123.0	74.4	0.24	12.7	52.7	51.9	113	138.4	82.1	0.36	14.5	48.3	48.1	154
	2338	400	6	114.0	72.4	0.21	12.7	66.7	61.6	92	144.4	90.0	0.31	14.5	59.8	57.3	121
			10	142.9	90.2	0.32	12.6	59.7	57.5	103	172.2	105.7	0.49	14.5	53.7	53.0	137
			14	158.3	99.1	0.44	12.6	56.3	55.2	113	185.5	112.5	0.65	14.5	51.0	50.8	154
	3214	550	6	134.6	88.7	0.36	12.7	69.8	63.8	92	174.3	112.1	0.55	14.5	63.1	59.9	121
			10	170.2	112.3	0.54	12.6	63.1	60.3	103	211.5	133.8	0.82	14.4	56.9	55.9	137
			14	190.6	124.6	0.71	12.6	59.6	58.2	113	231.4	144.1	1.07	14.4	54.0	53.6	154
250 & 300	1861	285	6	104.1	64.4	0.12	12.9	63.3	59.3	99	128.9	78.3	0.17	14.9	56.5	54.7	131
			10	128.5	78.7	0.19	12.9	56.3	54.7	111	149.9	89.9	0.28	14.8	50.8	50.4	149
			14	140.4	85.4	0.26	12.9	53.0	52.3	123	158.7	94.5	0.39	14.8	48.6	48.5	167
	2613	400	6	126.8	80.8	0.21	12.9	66.7	61.7	99	160.8	100.2	0.31	14.8	59.9	57.4	131
			10	158.7	100.4	0.32	12.9	59.9	57.7	111	191.5	117.7	0.49	14.8	53.8	53.2	149
			14	175.9	110.4	0.44	12.9	56.4	55.4	123	206.4	125.1	0.65	14.8	51.2	51.0	167
	3592	550	6	149.7	98.8	0.36	12.9	69.8	63.8	99	193.3	124.6	0.55	14.8	63.3	60.0	131
			10	188.7	125.1	0.54	12.8	63.2	60.4	111	235.0	149.1	0.82	14.8	57.1	56.0	149
			14	211.5	138.7	0.71	12.8	59.7	58.3	123	255.9	160.0	1.07	14.7	54.3	53.9	167
350 & 400	2629	285	6	285.0	145.4	0.12	13.8	63.6	59.5	126	179.6	109.6	0.17	16.2	56.9	55.0	170
			10	179.1	110.1	0.19	13.8	56.7	55.1	143	209.0	125.9	0.28	16.2	51.2	50.8	196
			14	195.5	119.5	0.26	13.8	53.4	52.8	160	222.0	132.5	0.39	16.1	48.9	48.8	221
	3690	400	6	175.9	112.7	0.21	13.8	67.1	62.0	126	222.7	139.7	0.31	16.1	60.4	57.8	170
			10	219.7	140.2	0.32	13.7	60.3	58.1	143	265.0	163.9	0.49	16.1	54.4	53.7	196
			14	243.5	153.8	0.44	13.7	56.9	55.8	160	286.2	174.5	0.65	16.1	51.8	51.5	221
	5073	550	6	206.7	137.8	0.36	13.7	70.2	64.1	126	265.5	173.3	0.55	16.1	63.8	60.5	170
			10	260.0	173.8	0.54	13.7	63.7	60.8	143	322.0	206.3	0.82	16.1	57.8	56.7	196
			14	289.5	192.1	0.71	13.7	60.4	58.9	160	351.0	221.8	1.07	16.0	55.0	54.7	221

① Refer to the Breeze™ AccuSpec selection software for additional coil selections and performance at other conditions.
 ② Coils are rated in compliance with ARI 410
 ③ Coil Circuits Available: 1/4, 1/2, 3/4 (Performance data shown above), and Full Circuits and is calculated by the Breeze™ AccuSpec program.
 ④ Coil Rows Available: 4 and 6
 ⑤ Fin Spacings Available: 6, 8, 10, 12, and 14
 ⑥ 1 Ton = 12 MBH

COOLING COIL DIMENSIONS



Figure 68.1 - DX Coil Drawing
(All dimensions in inches)

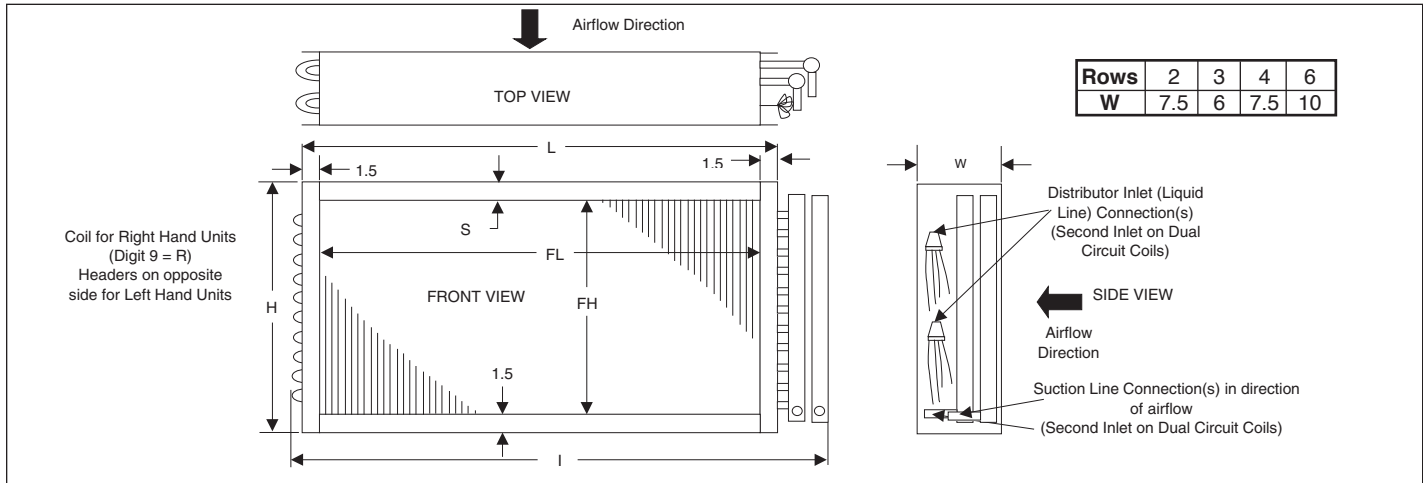

Table 68.1 - DX Coil Dimensions

Model Size	Cooling MBH	FH	H	S	Single Circuit			Dual Circuit		
					FL	I	L	FL	I	L
75	All	28	31	2	18	25	21	16	27	19
100/125	All	28	31	2	21	28	24	20	30	23
150/175	All	28	31	2	24	31	27	23	33	26
200/225	Below 185	33	35	0	27	34	30	26	36	29
	185 and Up	33	35	0	27	35	30			
250/300	Below 185	33	35	0	30	37	33	29	39	32
	185 and Up	33	35	0	30	38	33			
350/400	Below 185	33	35	0	42	49	45	40	51	43
	185 and Up	33	35	0	42	50	45			

Figure 68.2 - Chilled Water Coil Drawing
(All dimensions in inches)

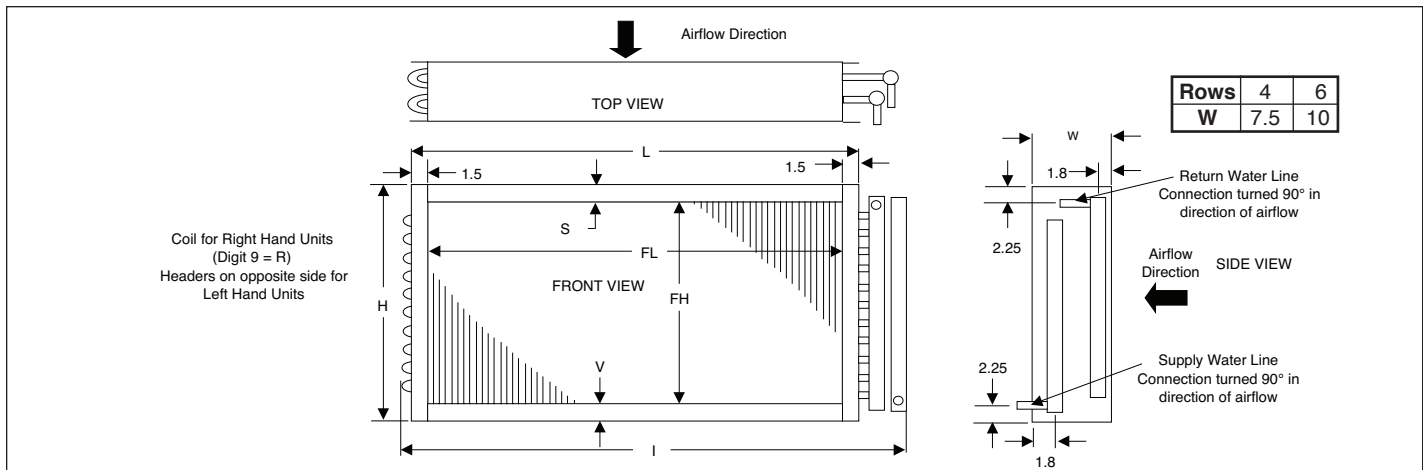

Table 68.2 - Chilled Water Coil Dimensions

Model Size	FH	H	S	V	FL	I	L	Supply Line	Return Line
75	27	30	1.5	1.5	16.25	25.50	19.25	1.50 MPT	1.50 MPT
100/125	27	30	1.5	1.5	19.50	28.75	22.50	1.50 MPT	1.50 MPT
150/175	27	30	1.5	1.5	23.00	32.25	26.00	1.50 MPT	1.50 MPT
200/225	33	34.5	0.5	1	25.50	34.75	28.50	1.50 MPT	1.50 MPT
250/300	33	34.5	0.5	1	28.50	37.75	31.50	1.50 MPT	1.50 MPT
350/400	33	34.5	0.5	1	40.25	49.50	43.25	1.50 MPT	1.50 MPT

Evaporative Cooling Module

All Outdoor models that include a blower section can be provided with a factory installed and wired evaporative cooling module. When applicable, evaporative cooling is one of the most economical means of supplying conditioned air to a space.

Evaporative cooling works on the principle of exchanging sensible heat from the entering warm air to latent heat of vaporization of the cooling water. A special wetting media is placed in the entering air stream of the cooling unit and water is fed down the media. As the air passes through the media, sensible heat from the air is simply transferred to the water in the cooling media, causing the water to evaporate. Because the sensible heat from the air is simply transferred to the water, and both the water vapor and cooled air remain in the system, there is no net energy change in the system. However, the dry bulb temperature of the air has been lowered and provides cooling for the space.

The temperature of the cooling air will be dependent on three criteria. These criteria are:

1. The design dry bulb temperature
2. The design wet bulb temperature
3. The percent effectiveness of the cooling media

The design dry and wet bulb temperatures can be obtained from the climatic table of the ASHRAE Fundamentals Handbook. The percent effectiveness of the cooling media is determined from the media performance curves shown in Curve 70.1 for either the 6" or 12" media based on the velocity across the media. The velocity can be determined by dividing the desired CFM of the unit by the face area of the cooling media for the unit. The media face areas are shown in the Evaporative Cooler Dimensional, Performance, and Weight Data Table 70.1. All evaporative coolers are designed to meet face velocities of 800 feet per minute without water carryover, thus eliminating the need for moisture elimination pads. For media pressure drops, refer to the evaporative cooling pressure drops included with the unit blower performance curves.

Evaporative coolers are available with 2 types of media:

1. Munters CELdek[®] Cellulose 6" and 12" media providing brand name media performance.
2. Munters GLASdek[®] Fiberglass 6" and 12" media which is a fiberglass media material for applications requiring UL 900, Class 2 fire rating and complies with NFPA codes. Required for ETL certification of System units.

Standard Features

- 6" Munters CELdek[®] evaporative cooling media.
- 18 gauge aluminized steel cabinet with a baked-on polyester powder paint finish on exterior casing parts.
- 304 stainless steel water reservoir.
- Factory installed and wired to electrical section terminal strip.
- Wire mesh birdscreen.
- Internal thermal overload protected motor.
- Front access to pump motor, media, and water connections.
- Float valve and bleed line.
- Adjustable leveling screws.
- Water inlet, drain, overflow connections (1/2" NPT).

Optional Features - Factory Installed

- 18 gauge 304 stainless steel cabinet - complete.
- 12" Munters CELdek[®] or 6" or 12" GLASdek[®] media.
- Pump motor for 230V/1Ph or 3Ph operation.
- Step-down transformers (250 VA) for 208V/1Ph or 208V/460V/575V/3Ph.

- Float switch - Prevents the pump motor from operating if the water level in the reservoir is below the switch.
- 1" polyester or aluminum mesh cleanable pre-filter.

Accessories - Field Installed

- Single stage duct thermostat.
- Manual remote operated fill and drain kit ①.
- Manual remote operated fill and drain kit with freeze protection ①.
- Automatic remote operated fill and drain kit ①.
- Automatic remote operated fill and drain kit with freeze protection ①.

① Valves rated for 50 PSI maximum water pressure.

Evaporative Cooling Performance Example

Determine the final dry bulb temperature for a model HBG200 with a rated air capacity of 4321 CFM with 12" GLASdek media. The unit is to be installed in Phoenix, Arizona. The ASHRAE guide shows a design dry bulb temperature of 109°F and a design wet bulb temperature of 71°F. This is plotted as Point A on Figure 70.2. Also determine the apparent cooling capacity of the evaporative cooler.

1. Determine the face velocity across the media located in Table 70.1. Find the model size and blower type of the selected unit and then find the corresponding media face area (For the model size 200 and all blowers, the media face area is 7.5 ft² of media). To calculate the face velocity:

$$\text{FPM} = \text{CFM} / \text{Media Face Area}$$

$$\text{or } 4321 \text{ CFM} / 7.5 \text{ ft}^2 = 576 \text{ FPM}$$

2. Determine the media percent effectiveness. Enter Figure 70.1 at 576 FPM and follow up the graph until the FPM line intersects with the 12" media % curve. At the point of intersection, read across to the left and find the percent effectiveness. For this example, the effectiveness is 89%.
3. Determine final dry bulb air temperature of conditioned air.

$$\text{LAT} = \text{EAT DB} - (\% \text{ Eff.} \times (\text{EAT DB} - \text{EAT WB}))$$

$$\text{LAT} = 109^\circ\text{F} - (0.89 \times (109^\circ\text{F} - 71^\circ\text{F})) = 75^\circ\text{F DB}$$

Once the final dry bulb temperature has been determined, the point of operation can be plotted on the psychrometric chart. The LAT dry bulb is 75°F and the wet bulb remains constant so it is 71°F. This is plotted as Point B on Figure 70.2.

4. Determine the cooling capacity of the unit. The cooling capacity of the unit is defined as the apparent cooling capacity because it is dependent on a specific set of temperature conditions. As these conditions change, so will the apparent cooling capacity.

$$Q = 1.08 \times (\text{EAT DB} - \text{LAT DB}) \times \text{CFM}$$

$$Q = 1.08 \times (109^\circ\text{F} - 75^\circ\text{F}) \times 4321 \text{ CFM} = 158,667 \text{ Btu/Hr}$$

5. Determine the pressure drop across the media and birdscreen. This number must be added to the internal static pressure of the unit when selecting a unit. This information is required to make a proper motor selection. The evaporative cooler pressure drop table can be found on page 36. Note that if the optional pre-filters are used, the proper pressure drop curve should be used.

Definition of Terms

EAT	=	Entering Air Temperature
LAT	=	Leaving Air Temperature
DB	=	Dry Bulb
WB	=	Wet Bulb
% Eff.	=	Percent Effectiveness
Q	=	Apparent Cooling Capacity

Figure 70.1
Evaporative Cooling Effectiveness Curve

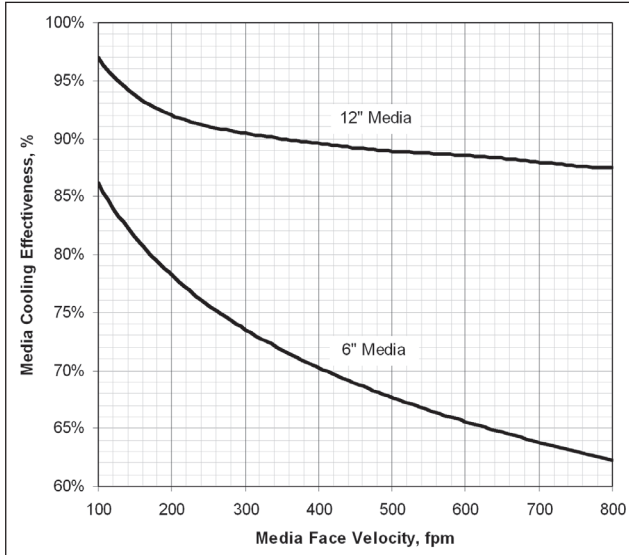

Figure 70.3
Evaporative Cooling Module

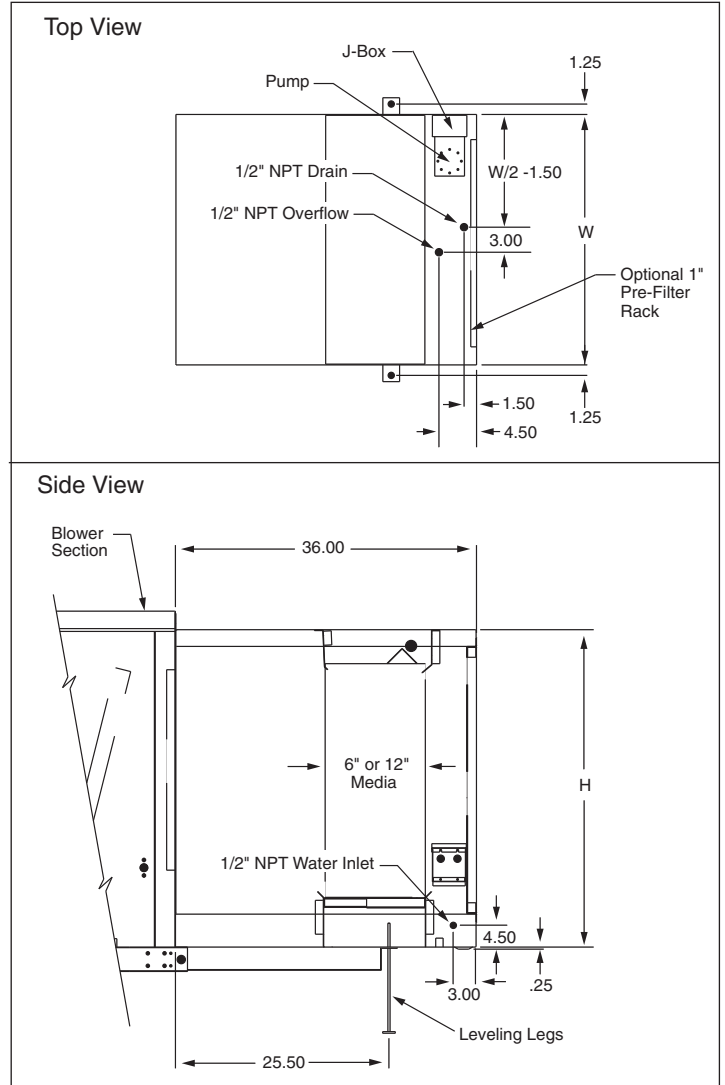

Figure 70.2
Psychrometric Chart

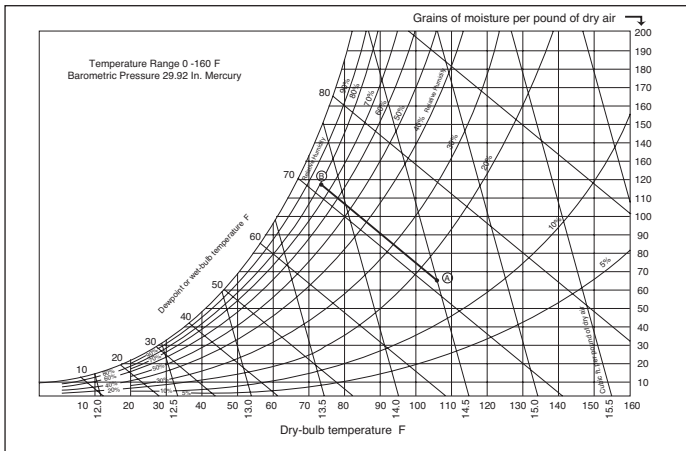

Table 70.1
Evaporative Cooler Dimensional, Performance, and Weight Data (All dimensions in inches)

Model Size	Blower Type (Digit 16)	H	W	Maximum Cooling CFM	Media Face Area (ft ²)	Face Velocity at Max CFM (ft/min)	6" Media ① (Digit 23 = 3 or 5)		12" Media ① (Digit 23 = 4 or 6)	
							Dry Weight	Operating Weight	Dry Weight	Operating Weight
75	All	34	30	2778	4.0	695	149	273	154	285
100/125	All	34	30	4000	5.0	800	154	280	159	295
150/175	All	34	36	5200	6.5	800	159	313	169	336
200/225	All	38	36	6000	7.5	800	164	318	174	341
250/300	E, F, G, or H	38	39	6500	8.1	800	171	338	182	363
250/300	I, J, or K	56	39	10400	13.0	800	200	371	214	404
350/400	E, F, G, or H	38	51	8500	10.6	800	211	433	228	473
350/400	I, J, or K	47	51	11050	13.8	800	225	450	244	496
500/600	G or H	38	39	6500	8.1	800	171	338	182	363
500/600	I, J, K or L	56	39	10400	13.0	800	200	371	214	404
700/800	G or H	38	51	8500	10.6	800	211	433	228	473
700/800	I, J, K or L	47	51	11050	13.8	800	225	450	244	496
840/960	I, J, K or L	47	51	11050	13.8	800	225	450	244	496

① All weights in pounds.

These specifications cover unit(s) _____ shown on the equipment schedule and in the plans.

General**A. Standards**

All unit(s) shall include:

- A.1. C.S.A. (Canadian Standards Association) design certification for use in both the US and Canada to the ANSI Z83.8 - latest revision, standard for "Gas Unit Heater and Gas-Fired Duct Furnaces" for safe operation, construction, and performance.
- A.2. ETL certified duct furnace, blower, cooling, downturn, and evaporative cooling sections to UL 1995/CSA C22.2 No. 236 "Heating and Cooling Equipment" and UL 795 "Commercial - Industrial Gas Heating Equipment" for electrical and mechanical safety.

B. Mechanical Configuration

All unit(s) shall have right side (opt left side), when looking into the discharge, access to all controls/venting and include:

- B.1. Furnace(s) section with 80% minimum efficiency provided by an indirect-fired heat exchanger with dimpled tube pattern for efficient heat transfer.
- B.2. Blower section containing a supply blower and motor with bottom support to provide rigidity. The blower connection shall be flexible with 1/4" gasket to prevent sound transmission into the supply ductwork.
- B.3. Electrical section isolated from the supply air stream including a hinged access door. Separate knock-outs shall be provided for both high and low voltage electrical connections. Provisions must be included for side access electrical connections for slab mounted units and bottom electrical connections for roof curb mounted or suspended units.
- B.4. Cooling coil cabinet section shall be shipped attached to and downstream of the heat exchanger. The blow through design shall prevent condensation on the heat exchanger in the cooling mode. The cabinet shall include a removable upper service access door and a stationary piping connection door. The drain pan shall be 409 stainless steel with drain and overflow connections.

Additional mechanical configurations for Outdoor only

- B.5. Downturn plenum section for downward deflection of the supply air.
- B.6. Evaporative cooling section shall be factory installed and wired to the terminal strip of the electrical section.
- B.7. Rainhood and birdscreen shall be pre-assembled from the factory and provided with internal baffles to prevent water entrainment in the supply air stream.
- B.8. Roof curb with wood nailing strips and assembly hardware. The roof curb members shall be 16" high to meet the National Roofing Contractors Association requirements and constructed from 16 gauge aluminized steel. The curb shall include:
 - B.8.a. (opt) insulation.
 - B.8.b. (opt) discharge air duct connector for field installation of ductwork prior to unit arrival.
 - B.8.c. (opt) return air duct connector for field installation of ductwork prior to unit arrival.

C. Indoor Gravity Vented Venting Arrangements

- C.1. The venting shall be gravity vented arrangement with a 45° angled round vent connection to allow for tighter installation to duct system components.

C. Indoor Separated Combustion Venting Arrangements

- C.2. The unit casing shall be designed for the venting/ combustion air arrangement to be separated from the room atmosphere. The unit shall have a factory mounted power exhauster enclosed in the unit casing to prevent the motor from being subjected to the room atmosphere. The unit shall also include a factory mounted differential pressure switch designed to prevent pilot and main burner ignition until positive venting has been proven. A removable gasketed door shall contain both the vent and combustion air connection collars to allow for servicing of the power exhauster.
- C.3. The unit shall include a factory supplied horizontal concentric vent kit allowing for a single penetration of the wall for both the combustion air supply and flue product exhaust.
- C.4. The unit shall include a factory supplied vertical concentric vent kit allowing for a single penetration of the roof for both the combustion air supply and flue product exhaust.
- C.5. The unit shall include two factory supplied vent caps for both the combustion air supply and flue product exhaust.

C. Outdoor Venting Arrangements

- C.6. The venting shall be a gravity vented arrangement with a combination combustion air / exhaust vent cap that minimizes the pressure differential between the inlet and exhaust of the venting system. This pressure differential shall reduce the burner flame disturbance to insure proper ignition when the unit is subjected to 40 mile per hour wind velocities. The cap shall prevent rain from entering the unit through the use of combustion air inlet louvers at a minimum of 6 inches from the unit roof.
- C.7. The venting shall be a power exhausted arrangement. The unit shall be tested to insure proper ignition when the unit is subjected to 40 mile per hour wind velocities.

D. Indoor Unit Casing

- D.1. The duct furnace(s) unit casing shall be constructed of not less than 20 gauge aluminized steel.
- D.2. The blower and cooling sections shall be constructed of not less than 18 gauge aluminized steel.
- D.3. All blower and cooling section exterior casing parts shall be painted with a baked-on gray-green polyester powder paint (7 mil thickness) for corrosion resistance.
- D.4. All blower and cooling section access side doors shall have heavy duty, draw tight, quarter turn latches.
- D.5. (opt) Blower and/or cooling sections shall include 1 inch, 1-1/2 lb density acoustical and thermal insulation. The insulation shall be made of glass fibers bonded with a thermosetting resin and overlaid with a fire-resistant black acrylic coating for additional strength. The acrylic coating must meet the requirements of ASTM C 665 for fungi resistance.

(opt) The blower and/or cooling sections shall include double wall construction in which 1 inch, 1-1/2 lb density insulation is covered by a 22 gauge aluminized steel liner. The liner shall conform to ASHRAE Standard 62-1989 Ventilation for Acceptable Indoor Air Quality.

Additional Unit Casing for Separated Combustion

- D.6. The duct furnace(s) shall include separate access doors for the power exhauster, electrical controls, and gas train to allow for simplified service of the unit.
- D.7. All duct furnace(s) doors shall be fully gasketed to prevent infiltration of the room air into the combustion process.

Outdoor Unit Casing

- D.8. The unit casing shall be constructed of not less than 18 gauge steel.
- D.9. All exterior casing parts shall be painted with a baked-on gray-green polyester powder paint (7 mil thickness) for corrosion resistance.
- D.10. All access side doors shall have heavy duty, draw tight, quarter turn latches.
- D.11. Blower, cooling, and downturn sections when provided shall include 1 inch, 1-1/2 lb density acoustical and thermal insulation. The insulation shall be made of glass fibers bonded with a thermosetting resin and overlaid with a fire-resistant black acrylic coating for additional strength. The acrylic coating must meet the requirements of ASTM C 665 for fungi resistance.
- D.12. (opt) The blower, cooling, and downturn sections when provided shall include double wall construction in which the standard insulation is covered by a 22 gauge aluminized steel liner. The liner shall conform to ASHRAE Standard 62-1989 Ventilation for Acceptable Indoor Air Quality.

E. Furnace Section

- E.1. The heat exchanger(s) shall be made of
20 gauge aluminized steel tubes and headers
(opt) 20 gauge 409 stainless steel tubes and headers

The thermal efficiency of the unit(s) shall be a minimum of 80% efficient for all air flow ranges. The restrictor shall be sized to maintain the unit(s) efficiency of 80% in the temperature range of 20°F-60°F or 20°F-100°F.

Each heat exchanger tube shall be individually and directly flame-fired. The heat exchanger tube shall be contoured and dimpled to provide efficient heat transfer and crimped to allow for thermal expansion and contraction. The flue collector box shall be made of 20 gauge aluminized steel.
- E.2. The heat exchanger(s) seams and duct connections shall be certified to withstand 3.0" W.C. external static pressure without burner flame disturbance.

- E.3. The burner(s) shall be made of the same material as the heat exchanger with a thickness of not less than 28 gauge. Burner(s) shall have non-clogging, slotted ports with a stainless steel separator strip designed for good lighting characteristics without noise of extinction for both natural and propane gas. The burner(s) shall be located for service removal without disconnecting the main gas supply piping.
- E.4. The bottom of the unit shall be angled for draining any condensation to the corners of the unit. The condensation shall be removed through openings in the bottom pan. The drain pan shall be constructed of 20 gauge aluminized steel.
(opt) 409 stainless steel.
- E.5. The gas manifold(s) piping shall allow for gas piping connection on the side of the unit for slab mounted units and through the unit bottom for roof curb mounted or suspended units. The manifold(s) shall include a ground joint union for ease of servicing of the orifices without removing the burner assembly or main gas valve string.
- E.6. The orifices shall be provided on both natural and propane gas with adjustable air shutters for controlling the primary air mixture.
- E.7. The ignition controller(s) shall be 100% shut-off with continuous retry for natural gas.
(opt) The ignition controller(s) shall be 100% shut-off with lockout for propane gas.
- E.8. The gas pressure shall be between 6-7" W.C for natural gas.
(opt) The gas pressure shall be 11-14" W.C. for propane gas.
- E.9. The solid state ignition system shall intermittently light the pilot each time the system is energized. Once the pilot is proven, the main gas valve shall open and allow gas flow to the main burner.
- E.10. The unit gas controls shall be provided with the following:
- E.10.a. Single-stage gas controls with a single-stage combination gas control, an ignition control, and a single-stage low voltage thermostat. The unit fires at 100% full fire based on a call for heat from a room thermostat.
- E.10.b. (opt) Two-stage gas controls with a two-stage combination gas control, an ignition control, and a two-stage low voltage thermostat. The unit fires at 50% fire on low stage or 100% fire on high stage of the unit based on the call for heat from either a room or duct thermostat.
- E.10.d. (opt) Electronic modulation gas controls with an electronic modulating/regulating gas control, combination gas valve, an ignition control, modulating amplifier, and either a modulating room thermostat or modulating duct thermostat with remote temperature set point adjuster. The thermostat can modulate the system gas flow between 40% through 100% full fire. The firing rate shall be controlled by a
(opt) duct sensor with remote temperature adjuster.
(opt) duct sensor with remote temperature adjuster and room override thermostat.
(opt) room thermostat.
- E.10.e. (opt) Electronic Modulation Master gas controls with an electronic modulating/ regulating gas control, combination gas valve, an ignition control, modulating amplifier and either a modulating room thermostat or modulating duct thermostat with remote temperature set point adjuster. The thermostat can modulate the gas flow between 40% through 100% full fire. Allows one duct sensing thermostat to control the firing rate of the Master duct furnace and up to three Slave duct furnaces. The Master furnace sends a signal to all of the gas valves so that they modulate at the same percentage. When the thermostat is satisfied, the amplifier cuts power to the combination gas valves of the Master unit and all Slave units which prevents gas flow to both the main and pilot burners. The firing rate shall be controlled by a
(opt) duct sensor with remote temperature adjuster.
(opt) duct sensor with remote temperature adjuster and room override thermostat.
(opt) room thermostat.
- E.10.f. (opt) Electronic Modulation Slave gas controls with an electronic modulating/regulating gas control, combination gas valve, and an ignition control, but does not include a modulating amplifier and does not require a discharge air thermostat. The modulating gas valve receives the modulation percentage from the Master duct furnace. Up to three Slave duct furnaces can be connected to one Master unit.
- E.10.g. (opt) Electronic Modulation - 0-10 Vdc External Input. Allows for control of the duct furnace firing rate by a Building Management System (BMS). Utilizes an electronic modulating/regulating gas control, combination gas valve, an ignition control, modulating signal conditioner, and an inverted 0-10 Vdc input signal provided by a BMS (0 Vdc being high fire and 10 Vdc being low fire). The gas controls can modulate the gas flow between 40% and 100% full fire. When the BMS thermostat (supplied by others) is satisfied, the BMS heat contact (supplied by others) opens to cut power to the combination gas valve which prevents gas flow to both the main and pilot burners.
- E.10.h. (opt) Electronic Modulation - 4-20 mA External Input. Allows for control of the duct furnace firing rate by a Building Management System (BMS). Utilizes an electronic modulating/regulating gas control, combination gas valve, an ignition control, modulating signal conditioner, and an inverted 4-20 mA input signal provided by a BMS (4 mA being high fire and 20 mA being low fire). The gas controls can modulate the gas flow between 40% and 100% full fire. When the BMS thermostat (supplied by others) is satisfied, the BMS heat contact (supplied by others) opens to cut power to the combination gas valve which prevents gas flow to both the main and pilot burners.
- E.11. A 1/8" manifold pressure tap shall be located after all valves to test the manifold pressure directly before the main burner orifices.
- E.12. The unit shall be provided with a single gas control transformer to step down the supply voltage to 24V.
- E.13. Separate line voltage and low voltage terminal strips shall be provided to prevent the unit from being miswired for premium unit and low voltage terminals for standard units.
- E.14. Automatic reset high limit switch.
(opt) Manual reset high limit switch.
- E.15. Provide the following factory installed options:
- E.15.a. (opt) A low gas pressure switch(s) prevents the burner from firing if the inlet gas pressure is below the minimum gas pressure.
- E.15.b. (opt) A high gas pressure switch(s) which prevents the burner from firing if the manifold gas pressure is above the maximum manifold gas pressure.
- E.15.c. (opt) An air flow proving switch shall be an adjustable differential pressure switch to insure air flow across the heat exchanger before allowing the gas controls to be energized.
- E.15.d. (opt) A timed freeze protection discharge air thermostat used to prevent building freeze up in the event of a burner failure. The timer shall be adjustable from 1 to 5 minutes.
- E.15.e. (opt) A manual reset supply air fire stat shall shut the system down if the temperature at the limit switch location exceeds 200°F.
- E.15.f. (opt) A time delay relay which delays the start of the blower to allow the heat exchanger a warm-up period after a call for heat. The time delay relay shall also continue the blower operation after the thermostat has been satisfied to remove any residual heat on the heat exchanger.
- E.16. The unit shall be orificed for up to 2000' elevation above sea level.
(opt) The unit shall be orificed for _____ elevation above sea level.
- F. Electrical Section**
- F.1. All electrical components shall carry UL, ETL, or CSA listing.
- F.2. The unit shall be supplied with a disconnect switch to disconnect power to the unit for servicing. The disconnect switch style shall be
- Dead-Front fusible.
 - Dead-Front circuit breaker.
 - field installed non-fusible box type.
 - field installed fusible box type.
- F.3. A single step down transformer shall be provided for all unit controls.
- F.4. For 460V and 575V units, a step down transformer from line voltage to 115V shall be provided for operation of the power exhaustor motor.

G. Blower Section

- G.1. The blower motor shall meet the following requirements.
- G.1.a. The blower motor type shall be
- Single-speed, open drip proof (ODP)
 - Single-speed, totally enclosed (TE)
 - Single-speed, ODP, high efficiency (ODP HE)
 - Single-speed, TE, high efficiency (TE HE)
- G.1.b. The motor shall be rated for
- | | |
|-------------------|-------------------|
| (a) 115V/60Hz/1Ph | (e) 230V/60Hz/3Ph |
| (b) 208V/60Hz/1Ph | (f) 460V/60Hz/3Ph |
| (c) 230V/60Hz/1Ph | (g) 575V/60Hz/3Ph |
| (d) 208V/60Hz/3Ph | |
- G.1.c. The motor horsepower shall be ____.
- G.1.d. The motor wiring shall be in flexible metal BX conduit.
- G.1.e. The motor shall be provided with an adjustable motor sheave to allow for minor adjustment of the blower rpm at the job site.
- G.1.f. The motor shall be controlled by a time delay relay (opt) and motor starter. (opt) and variable frequency drive.
- G.2. The unit shall contain a single supply blower that is supported from the bottom to prevent the blower flanges supporting the weight of the motor. The blower shall be a double width, double inlet (DWDI), forward curved, belt driven, assembly with (std) spider ball bearings. (opt) heavy duty, pillow block ball bearings. (opt) motor and blower vibration isolation using rubber-in-shear grommets. (opt) extended grease lines which include external zerk fittings for applying grease.
- G.3. (opt) The unit shall be provided with a filter rack with
- | | |
|--------------------------|---|
| (a) 1" permanent filters | (c) 2" FARR® Aeropleat 3 filters (MERV 7) |
| (b) 2" permanent filters | (d) 2" FARR® 30/30 filters (MERV 8) |
- G.4. (opt) Dampers and Damper Controllers
- G.4.a. All fresh air dampers are ultra low leak, Class II leakage resistance (less than 10 CFM/ft² at 1" W.C.) dampers with self-compensating stainless steel side seals and santoprene and galvanized steel blade seals. All return air dampers, which are used for air balancing, shall be low leak, Class III leakage resistance (less than 40 CFM/ft² at 1" W.C.) dampers with self-compensating stainless steel side seals and santoprene blade seals.
- G.4.b. The damper actuator shall be mounted directly to the shaft of the fresh air damper. If return air dampers are provided, a damper linkage rod shall be provided to set the positions of the opposed dampers.
- G.4.c. The damper actuator shall be spring return so when power is disconnected, the damper closes the outside air opening.
- G.4.d. All two-position damper actuators shall have one normally open and one normally closed end switch to prove that the damper has opened.
- G.4.e. Air Control AA - The unit shall be provided with a return air opening in the bottom of the unit.
- G.4.f. Air Control BA - The unit shall be provided with a fresh air opening in the back of the unit.
- G.4.g. Air Control CA = The unit shall be provided with fresh air and return air openings in both the bottom and the back of the unit.
- G.4.h. Air Control DA = The unit shall be provided with fresh air dampers with a two-position damper motor with no return air.
- G.4.i. Air Control EA = The unit shall be provided with fresh air and return air dampers with a two-position damper motor.
- G.4.j. Air Control EQ = The unit shall meet ASHRAE Cycle I and be provided with fresh air and return air dampers with a two-position damper motor with warm-up thermostat.
- G.4.k. Air Control FA = The unit shall be provided with fresh air dampers and return air opening with a two-position damper motor.
- G.4.l. Air Control GA = The unit shall be provided with fresh air and return air dampers with a modulating damper motor with 0-10 Vdc external input signal control.
- G.4.m. Air Control GB = The unit shall be provided with fresh air and return air dampers with a modulating damper motor with 4-20 mA external input signal control.
- G.4.n. Air Control GC = The unit shall be provided with fresh air and return air dampers with a modulating damper motor with minimum positioner.
- G.4.o. Air Control GD = The unit shall be provided with fresh air and return air dampers with a modulating damper motor with remote positioner.
- G.4.p. Air Control GE = The unit shall be provided with fresh air and return air dampers with a modulating damper motor for three positions.
- G.4.q. Air Control GF = The unit shall be provided with fresh air and return air dampers with a modulating damper motor with A350P proportional temperature controller.
- G.4.r. Air Control GG = The unit shall be provided with fresh air and return air dampers with a modulating damper motor with minimum positioner and A350P proportional temperature controller.
- G.4.s. Air Control GH = The unit shall be provided with fresh air and return air dampers with a modulating damper motor with remote positioner and A350P proportional temperature controller.
- G.4.t. Air Control GJ = The unit shall be provided with fresh air and return air dampers with a modulating damper motor with fresh air enthalpy controller.
- G.4.u. Air Control GK = The unit shall be meet ASHRAE Cycle II and be provided with fresh air and return air dampers with modulating a damper motor with minimum positioner, A350P proportional temperature controller, and warm-up thermostat.
- G.4.v. Air Control GM = The unit shall meet ASHRAE Cycle II and be provided with fresh air and return air dampers with a modulating damper motor with remote positioner, A350P proportional temperature controller, and warm-up thermostat.
- G.4.w. Air Control GN = The unit shall meet ASHRAE Cycle III and be provided with fresh air and return air dampers with a modulating damper motor with A350P proportional temperature controller, and warm-up thermostat.
- G.4.x. Air Control HP = The unit shall be provided with fresh air and return air dampers with a floating damper motor with photohelic space pressure controller.
- G.4.y. Air Control JA = The unit shall be provided with manual fresh air and return air dampers.
- G.4.z. Air Control KA = The unit shall be provided with manual fresh air dampers and return air opening.
- G.5. The unit shall be provided with the following factory installed options:
- G.5.a. (opt) A mild temperature thermostat used to automatically lock out the gas controls when the outdoor temperature reaches the desired set point.
- G.5.b. (opt) A manual reset return air fire stat that shuts the system down if the temperature in the blower section exceeds 120°F.
- G.5.c. (opt) A blower door safety switch that breaks power to the unit low voltage control circuit when the blower door is opened. The switch can be manually overridden for servicing.
- G.5.d. (opt) A set of three service switches for manual operation of the damper, blower, and burner by service personnel.
- G.5.e. (opt) A convenience outlet with a 115V GFCI service receptacle mounted in the blower compartment for a separate 115V power supply.
- G.5.f. (opt) A two-position damper limiter to manually fix the percentage of outside air for units with two-position fresh and return air dampers.
- G.5.g. (opt) A dirty filter pressure switch with an adjustable pressure switch with pick-up tubes to monitor the filter pressure drop and energize a remote panel light if the set pressure is exceeded.
- G.5.h. (opt) A circuit analyzer consisting of (6 or 10) lights that step through the sequence of operation for service personnel.
- G.5.i. (opt) A fresh air discharge damper that is ultra low leak, Class II leakage resistance (less than 10 CFM/ft² at 1" W.C.) dampers with self-compensating stainless steel side seals and santoprene and galvanized steel blade seals. The damper actuator shall be mounted directly to the shaft of the fresh air discharge damper. The damper actuator shall be spring return so when power is disconnected, the damper closes the outside air opening. The damper actuator shall have one normally open and one normally closed end switch to prove that the damper has opened.

H. Mounting Base

- H.1. The unit shall be provided with a 14 gauge, galvanized steel, rail type mounting base for slab installation with lifting and anchoring holes.
- H.2. The unit shall be provided with a 14 gauge, galvanized steel, combination curb and slab type mounting base with lifting and anchoring holes.

I. Evaporative Cooler for Outdoor Only

- I.1. The unit shall be provided with
 - (a) 6" Munters CELdek® media (c) 6" Munters GLASdek® media
 - (b) 12" Munters CELdek® media (d) 12" Munters GLASdek® media
- I.2.a. The casing of the evaporative cooler shall be 18 gauge aluminized steel with a baked-on polyester power paint (7 mil thickness) for corrosion resistance.
- I.2.b. The casing of the evaporative cooler shall be 18 gauge 304 stainless steel for corrosion resistance.
- I.3. The water reservoir shall be 18 gauge 304 stainless steel.
- I.4. The unit shall include a wire mesh birdscreen that is removable to allow front access to the pump motor, media, and water connections.
- I.5. The pump motor shall have internal thermal overload protection.
- I.6. Field adjustable leveling screws shall be provided to support the weight of the evaporative cooler on the roof.
- I.7. The evaporative cooler will be provided with the following factory installed controls:
 - I.7.a. A step down transformer for the pump motor.
 - I.7.b. A 1" permanent polyester cleanable pre-filter to prevent debris from entering the unit.
 - I.7.c. A float switch to prevent the pump motor from operating if the water level in the reservoir is below the switch.
 - I.7.d. A 1" aluminum mesh cleanable pre-filter to prevent debris from entering the unit.
- I.8. The evaporative cooler will be provided with the following field installed controls:
 - I.8.a. A single stage duct thermostat to control the operation of the pump motor.
 - I.8.b. A manually operated remote fill and drain kit to fill the water reservoir when the unit is in cooling mode. When not in operation, the water shall be drained to prevent the recirculation of stagnant water.
 - I.8.c. A manually operated remote fill and drain kit with freeze protection to fill the water reservoir when the unit is in cooling mode. When not in cooling mode, the water shall be drained to prevent the recirculation of stagnant water. The freeze thermostat shall prevent the evaporative cooler from filling when the outside air temperature is below the set point.
 - I.8.d. An automatic fill and drain kit to fill the water reservoir, controlled by a time clock, when the unit is in cooling mode. When not in cooling mode, the water shall be drained to prevent the recirculation of stagnant water.
 - I.8.e. An automatic fill and drain kit with freeze protection to fill the water reservoir, controlled by a time clock, when the unit is in cooling mode. When not in cooling mode, the water shall be drained to prevent the recirculation of stagnant water. The freeze thermostat shall prevent the evaporative cooler from filling when the outside air temperature is below the set point.

J. Accessory Control Devices

The following field installed accessory control devices shall be provided with the unit:

- J.1. A digital 7-day / 24-hour timer with SPDT switching. The timer shall have 16 programming set points with 7-day power outage carry-over.
- J.2. A push pin style appliance timer with SPST switching with 12 settings per day (2 hour per pin time increments).
- J.3. A mild temperature thermostat used to automatically lock out the gas controls when the outdoor temperature reaches the desired set point.
- J.4. A low profile duct style photoelectronic smoke detector with two DPDT contacts.
 - J.4.a. A smoke detector tube extension for duct widths between 1 to 2 feet.
 - J.4.b. A smoke detector tube extension for duct widths between 2 to 4 feet.
 - J.4.c. A smoke detector tube extension for duct widths between 4 to 8 feet.
- J.5. A freeze stat to shut the fresh air dampers if the outside temperature falls below the set point.
- J.6. A 1-5 psi gas pressure regulator to reduce the inlet gas pressure for the operating controls.
- J.7. A clear plastic thermostat guard with two keys for room thermostats.

- J.8. A DPDT summer winter switch for continuous fan in the summer position and intermittent fan and burner in the winter position.
- J.9. A remote manual positioner for controlling the percentage of fresh and return air on units provided with modulating damper actuators.
- J.10. A 4 foot vent extension to increase the height of the unit exhaust.
- J.11. A remote panel with the following
 - J.11.a. ___ indicator lights
 - J.11.b. ___ three position switch
 - J.11.c. ___ two position switches
 - J.11.d. ___ thermostat
 - J.11.e. ___ minimum damper positioner

K. Thermostats

The unit shall be provided with the following thermostat

- K.1. A single stage room thermostat with a 55°-95°F range.
- K.2. A single stage room thermostat with a 45°-75°F range
- K.3. A single stage room thermostat with a 45°-75°F range with sub-base for System auto/off and Fan auto/on control.
- K.4. A 7-day programmable room thermostat with with one heat and one cool stage. The thermostat shall have Fan on/auto and System heat/off/cool/auto switching. Programmable for 2 to 4 events per day with override feature and one auxiliary output terminal for damper control.
- K.5. A two-stage room thermostat with a 42°-88°F range.
- K.6. A two-stage room thermostat with a 42°-88°F range with sub-base for System auto/off and Fan auto/on control.
- K.7. A 7-day programmable room thermostat with with two heat and two cool stages. The thermostat shall have Fan on/auto and System heat/off/cool/auto switching. Programmable for 2 to 4 events per day with override feature and one auxiliary output terminal for damper control.
- K.8. A factory installed two-stage duct thermostat with a 0°-100°F range and 20 foot capillary.
- K.9. A field installed two-stage duct thermostat with a 0°-100°F range and 20 foot capillary.
- K.10. A factory installed two-stage duct thermostat with a 55°-175°F range and 20 foot capillary.
- K.11. A field installed two-stage duct thermostat with a 55°-175°F range and 20 foot capillary.
- K.12. A two-stage electronic duct thermostat with factory installed temperature sensor and field installed temperature selector and one (up to two) stage adder.
- K.13. A two-stage electronic duct thermostat with field installed temperature sensor, temperature selector and one (up to two) stage adder.
- K.14. A factory installed electronic modulating duct thermostat with a range of 55°-90°F.
- K.15. A remote set point adjuster for the electronic modulating duct thermostat.
- K.16. A field installed electronic modulating duct thermostat and set point adjuster with a range of 55°-90°F.
- K.17. A room override thermostat with a range of 40°-90°F for use with the electronic modulating duct thermostat.
- K.18. An electronic modulating room thermostat with a 60°-85°F range.

L. Cooling Coil

The unit shall be provided with a factory installed cooling coil with a face velocity not to exceed 550 feet per minute.

- L.1. A direct expansion (DX) single circuit cooling coil that is rated in compliance with ARI 410. The coil shall have 0.016 copper tubes with 0.0075 aluminized steel fins. The coil casing shall be galvanized steel with mounting flanges.
- L.2. A direct expansion (DX) dual circuit cooling coil that is rated in compliance with ARI 410. The coil shall have 0.016 copper tubes with 0.0075 aluminized steel fins. The coil casing shall be galvanized steel with mounting flanges.
- L.3. A chilled water cooling coil that is rated in compliance with ARI 410. The coil shall have 0.020 copper tubes with 0.0075 aluminized steel fins. The coil casing shall be galvanized steel with mounting flanges.



1	2	3	4 5 6	7	8	9	10	11	12	13	14	15	16	17	18	19	20 21	22	23
PT	UC	V	MBH	HE	DS	AS	ATR	GT	GV	SS	SV	TR	BB	HP	MT	SA	AC	EC	CC

1 - Product Type (PT)

- D - Indoor HVAC Unit
- H - Outdoor HVAC Unit

2 - Unit Configuration (UC)

- F - Furnace
- B - Blower Package - Furnace & Blower
- C - Cooling Package - Furnace, Blower, & Cooling Cabinet
- D - Downturn Package - Furnace, Blower, & Downturn
- P - Packaged Unit - Furnace, Blower, Cooling Cabinet, & Downturn

3 - Venting (V)

- G - Gravity
- P - Power
- S - Separated Combustion

4,5,6 - Furnace Input Rating (MBH) (Output on 840 & 960)

- 100 - 100,000 Btu/Hr Input
- 175 - 175,000 Btu/Hr Input
- 250 - 250,000 Btu/Hr Input
- 400 - 400,000 Btu/Hr Input
- 500 - 500,000 Btu/Hr Input
- 600 - 600,000 Btu/Hr Input
- 840 - 1,050,000 Btu/Hr Input
- 960 - 1,200,000 Btu/Hr Input

7 - Heat Exchanger/Burner/Drip Pan Material (HE)

- A - Aluminized Steel
- S - 409 Stainless Steel Heat Exchanger/Burner
- T - 409 Stainless Steel Heat Exchanger/Burner/Drip Pan

8 - Development Sequence Designation (DS)

- F - Single Stage
- M - Two-stage or Modulating

9 - Access Side (AS)

- R - Right Hand
- L - Left hand

10 - Air Temperature Rise (ATR)

- H - High 60°-100°F
- L - Low 20°-60°F
- N - Not Used (Indoor Gravity Vented Only)

11 - Gas Type (GT)

- N - Natural with ignition controller
- P - Propane with ignition controller

12 - Gas Valve (GV)

- 1 - Single Stage
- 2 - Two Stage
- 4 - Electronic Modulation
- 5 - Electronic Modulation Master
- 6 - Electronic Modulation Slave
- 7 - Electronic Modulation 0-10 Vdc External Input
- 8 - Electronic Modulation 4-20 mA External Input

13 - Additional Safety Switches (SS)

- 4 - No Switches (Standard)
- 0 - No Switches (Premium)
- 1 - Low Gas Pressure Switch (Premium)
- 2 - High Gas Pressure Switch (Premium)
- 3 - High and Low Gas Pressure Switch (Premium)

14 - Supply Voltage (SV)

- A - 115/60/1
- B - 208/60/1
- C - 230/60/1
- D - 208/60/3
- E - 230/60/3
- F - 460/60/3
- G - 575/60/3

15 - Transformer (TR)

- 1 - 40 VA
- 2 - 75 VA
- 3 - 150 VA
- 4 - 250 VA
- 0 - None

16- Blower Size & Bearing Type (BB)

- A - 9-7 Spider Bearings
- B - 9-7 Pillow Block Bearings
- C - 9-9 Spider Bearings
- D - 9-9 Pillow Block Bearings
- E - 12-12 Spider Bearings
- F - 12-12 Pillow Block Bearings
- G - 15-15 Spider Bearings
- H - 15-15 Pillow Block Bearings
- I - 18-18 Spider Bearings under 15 Hp
- J - 18-18 Pillow Block Bearings under 15 Hp
- K - 18-18 Pillow Block Bearings for 15 Hp & up
- L - 20-18 Pillow Block Bearings

17- Motor Horsepower (HP)

- A - 1/3 Hp
- B - 1/2 Hp
- C - 3/4 Hp
- D - 1 Hp
- E - 1-1/2 Hp
- F - 2 Hp
- G - 3 Hp
- H - 5 Hp
- I - 7-1/2 Hp
- J - 10 Hp
- K - 15 Hp
- V - 20 Hp
- L - 1/3 Hp with Motor Starter
- M - 1/2 Hp with Motor Starter
- N - 3/4 Hp with Motor Starter
- P - 1 Hp with Motor Starter
- Q - 1-1/2 Hp with Motor Starter
- R - 2 Hp Hp with Motor Starter
- S - 3 Hp with Motor Starter
- T - 5 Hp with Motor Starter
- W - 7-1/2 Hp with Motor Starter
- X - 10 Hp with Motor Starter
- Y - 15 Hp with Motor Starter
- Z - 20 Hp with Motor Start

18- Motor Type (MT)

- 1 - ODP
- 2 - ODP - High Eff.
- 5 - TE
- 6 - TE - High Eff.

19- Sheave Arrangement (SA)

- A - (See Sheave Tables)

20,21 - Air Control (AC)

- AA - RA Opening
- BA - FA Opening
- CA - FA & RA Openings
- DA - FA Dampers w/ 2 position motor (No RA)
- EA - FA & RA Dampers w/ 2 position motor
- EQ - ASHRAE Cycle I - ("EA" with Warm-up Stat)
- FA - FA Damper & RA Opening w/ 2 position motor
- GA - FA & RA Mod motor w/ 0-10 Vdc External Input
- GB - FA & RA Mod motor w/ 4-20 mA External Input
- GC - FA & RA Mod motor w/ Minimum Position
- GD - FA & RA Mod motor w/ Remote Position (On Remote Panel)
- GE - FA & RA Mod motor w/ 3 pos. damper (100% RA, Variable, 100% OA)
- GF - FA & RA Mod motor w/ A350P Proportional Temp Controller
- GG - FA & RA Mod motor w/ Minimum Position & Prop. Temp Controller
- GH - FA & RA Mod motor w/ Remote Position & Prop. Temp Controller
- GJ - FA & RA Mod motor w/ FA Enthalpy Controller
- GK - ASHRAE Cycle II - ("GG" with Warm-up Stat)
- GM - ASHRAE Cycle II - ("GH" with Warm-up Stat)
- GN - ASHRAE Cycle III - ("GF" with Warm-up Stat)
- HP - FA & RA Floating motor w/ Space Pressure Controller
- JA - Manual FA & RA Dampers
- KA - Manual FA Damper with Return Air Opening
- OA - Other

22 - Evaporative Cooling (EC)

- 3 - 6" CELdek Media
- 4 - 12" CELdek Media
- 5 - 6" GLASdek Media
- 6 - 12" GLASdek Media
- 0 - None
- A - 6" CELdek Media, Stainless Steel Casing
- B - 12" CELdek Media, Stainless Steel Casing
- C - 6" GLASdek Media, Stainless Steel Casing
- D - 12" GLASdek Media, Stainless Steel Casing

23 - Cooling Coil (CC)

- 0 - None
- 1 - Factory Installed Coil

Products from Modine are designed to provide indoor air-comfort and ventilation solutions for residential, commercial, institutional and industrial applications. Whatever your heating, ventilating and air conditioning requirements, Modine has the product to satisfy your needs, including:

HVAC

- Unit Heaters:
 - Gas
 - Hydronic
 - Electric
 - Oil
- Ceiling Cassettes
- Duct Furnaces
- Hydronic Cabinet Unit Heaters, Fin Tube, Convectors
- Infrared Heaters
- Make-up Air Systems
- Unit Ventilators

Ventilation

- Packaged Rooftop Ventilation

School Products

- Vertical Packaged Classroom HVAC:
 - DX Cooling/Heat Pump
 - Water/Ground Source Heat Pump
 - Horizontal/Vertical Unit Ventilators

Geothermal

- Water-to-Water
- Water-to-Air
- Combination

Specific catalogs are available for each product. Catalogs 75-136 and 75-137 provide details on all Modine HVAC equipment.



Modine Manufacturing Company

1500 DeKoven Avenue
Racine, Wisconsin 53403-2552
Phone: 1.800.828.4328 (HEAT)
www.modinehvac.com

© Modine Manufacturing Company 2013