

INSTALLATION INSTRUCTIONS
vibration isolation hangers and low profile ceiling mounting brackets[®]
models HD, HDB, HDS, and HDC

[®] ceiling mounting bracket kit accessory for model size 100 and 125 only

IMPORTANT

1. The use of this manual is specifically intended for a qualified installation and service agency. All installation and service of these kits must be performed by a qualified installation and service agency.
2. These instructions must also be used in conjunction with the Installation and Service (I&S) Manual originally shipped with the appliance being converted, in addition to any other accompanying component supplier literature.

VIBRATION ISOLATION HANGER KIT

Model Application

All mechanical equipment with moving parts has the potential to generate sound and vibration. Many factors can affect the level of vibration transmitted to the supporting structure including the installation method, design, and construction of the supporting structure, and the design of the unit itself.

Modine offers vibration isolation kits for Models HD/HDB & HDS/HDC, that when used in combination with these instructions, can reduce unit vibration transmitted to the structure to a negligible amount. The items and quantity required for installation are as follows:

Qty Req'd	Component	Source	Kit Item Code [Ⓛ]	
			36987	63053
	Vibration Isolator & 1.5" Fender Washer	In Kit	4	6
	3/8" Nuts	<i>By Others</i>	28	42
	3/8" Washer	<i>By Others</i>	16	24
	3/8" Threaded Rod	<i>By Others</i>	8	12

[Ⓛ] All Sizes without a Blower Enclosure Accessory uses kit 36987.
 All Sizes with a Blower Enclosure Accessory uses kit 63053.

To ensure that the maximum vibration isolation is achieved, follow these instructions in detail. For complete installation instructions, please refer to the latest revision of I&S Manual 6-583 for HD/HDB models and 6-584 for HDS/HDC models.

Assembly/Installation

The recommended procedure for assembly and installation is described as follows (for each step, refer to Figure 1.1):

1. Install the 3/8" threaded rod to the supporting structure in accordance with I&S Manual that shipped with the model being installed. Space the rods according to the hole locations on the unit. To increase the effectiveness of the isolation, ensure that the threaded rods are vertical. Creating a template of the rail spacing may be useful in transferring the distances.

2. Place a nut approximately 3/4" from the end of the hanging rod. Below this nut, install a washer and the vibration isolation hanger. The hanger should be in a vertical orientation with the neoprene isolator at the bottom. Secure the hanger with a washer and nut. The nuts above and below the vibration isolation hanger should be tightened to prevent the nuts from loosening.
3. Once the vibration isolation hanger has been adequately attached to the threaded rod, guide a section of threaded rod that will eventually be secured to the unit, through the bottom of the hanger so that it protrudes above the top of the neoprene isolator. Place the 1.5" fender washer that was included with the kit, followed by two nuts on the threaded rod and tighten the two nuts against each other to prevent the nuts from loosening.
4. At the end of the threaded rod, place one nut approximately 1-1/2" from the bottom end of the rod. Before suspending the unit, repeat steps 1-4 for the remaining suspension rod/vibration hangers.
5. Once the threaded rod/vibration hangers installation steps 1-4 are complete, suspend the unit by placing a washer on the end of the threaded rod, followed by the unit through the appropriate hole in the mounting bracket, followed by a washer, and two nuts. Repeat for the other suspension points. Ensure that the unit is level as outlined in the unit I&S Manual and tighten the nuts closest to the bracket on the bottom. This will secure the unit against the previously installed nut from step 4. Tighten the 2nd nut under the bracket so the double nut arrangement will keep the nuts from loosening.
6. Verify the unit is level, then continue with the installation instructions in the I&S Manual that shipped with the unit.

Figure 1.1 – Vibration Isolation Detail

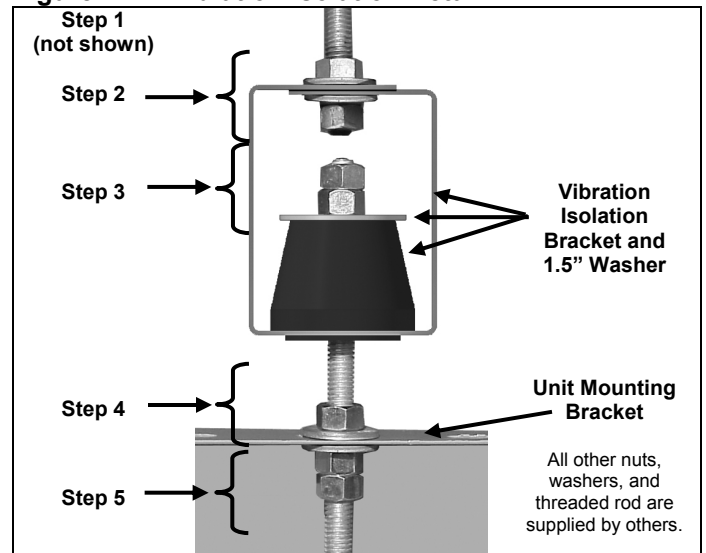

INSTALLATION – LOW PROFILE CEILING MOUNTING BRACKET ACCESSORY

MODELS HD/HDB, HDS/HDC, SIZES 100 & 125 ONLY

LOW PROFILE CEILING MOUNTING BRACKET ACCESSORY

Model Application

Models HD/HDB and HDS/HDC, size 100 and 125, come standard with provisions for mounting with threaded rod through the 3/8" mounting holes located in the top panel of the unit. For applications where the unit is to be mounted 1" from the ceiling, the low profile ceiling mounting bracket kit is an available accessory. The kit includes 2 brackets and hardware to mount the brackets to the unit.

To ensure that the unit is properly suspended, follow these instructions in detail. For complete installation instructions, please refer to the latest revision of I&S Manual 6-583 for HD/HDB models and 6-584 for HDS/HDC models.

Assembly/Installation

The recommended procedure for assembly and installation is described as follows (for each step, refer to Figure 2.1):

1. Review the model number on the unit serial plate to ensure that the brackets are being installed on the correct type of unit. These brackets can ONLY be used on models HD/HDB and HDS/HDC, sizes 100 and 125.
2. Attach both brackets to the unit suspension holes using the hardware supplied with the bracket kit. Each bracket is attached using (2) 3/8-16 x 1" hex head machine bolts and (2) 3/8" split washers. See Figure 2.1 for correct bracket orientation and hardware installation.
3. Install the unit to the building structure following the Installation and Service Instructions that originally shipped with the unit. Be sure to follow all cautionary notes.

Figure 2.1 – Low Profile Ceiling Bracket Installation

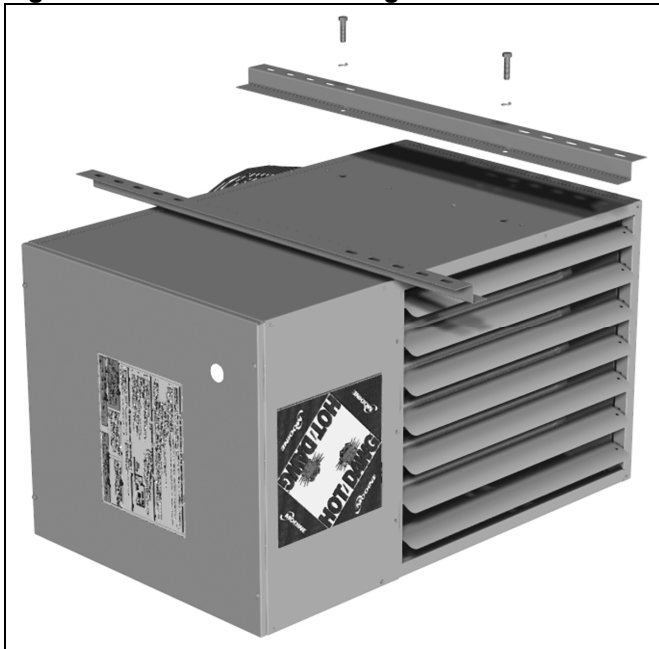

Modine Manufacturing Company has a continuous product improvement program, and therefore reserves the right to change design and specifications without notice.