

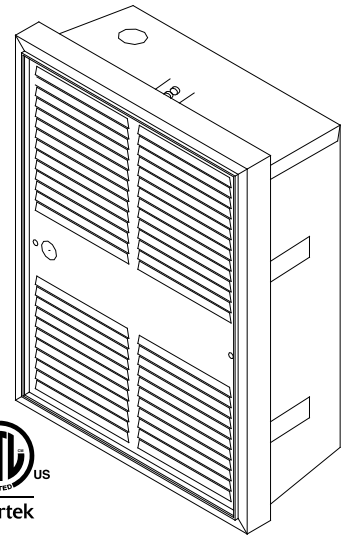

MADE IN THE U.S.A.

# 305 SERIES FAN FORCED WALL HEATER



CUSTOMER		DATE:	
PROJECT			
LOCATION			
ARCHITECT			
ENGINEER			
CONTRACTOR			
SUBMITTED BY			
APPROVED BY			
APPROVED BY			

## SUBMITTAL DATA SHEET

QTY	MODEL	TAG	WATTAGE	VOLTS	PHASE	AMPS	DISCONNECT	THERMOSTAT

NOTES/SPECIAL INSTRUCTIONS:

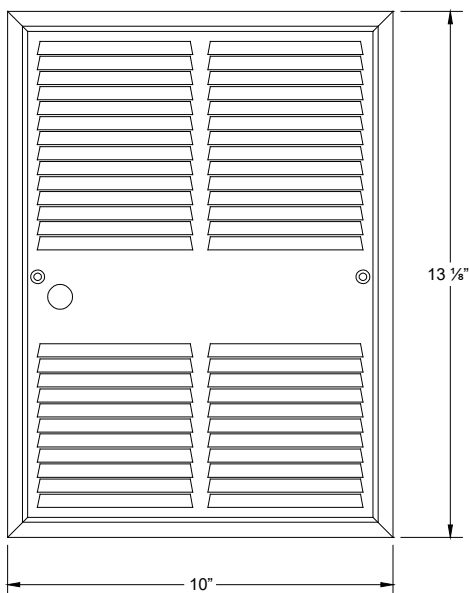

Rough In Dimensions  
9 1/4"W x 12 1/8"H x 3 5/8"D

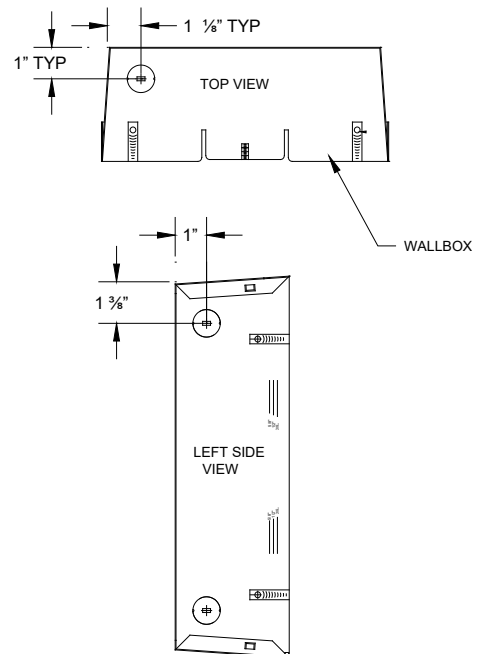

- Heavy-duty 18 gauge steel construction
- Powder coated paint finish
- Steel block fin element
- All units equipped with automatic over-heat limit protection
- Propeller style fan blade produces 100 CFM
- Dual wattage and voltage units available for 208/240 volts
- Surface Mounting Frames available for non-recessed and semi-recessed applications
- Units built with factory installed Tamper-Proof Thermostats, Automatic Fan Purge and Disconnect (see catalog for additional options)
- Made in U.S.A.

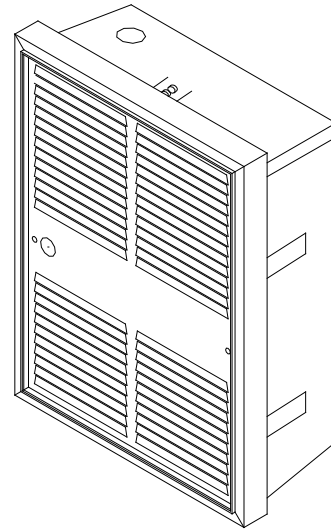

### Standard Models

MFG CATALOG NUMBER	MFG MODEL NUMBER	SELECTABLE INSTALLATION WATTAGE	MAX BTUs	VOLTS	MAX AMPS
TAMPERPROOF IN-BUILT DOUBLE POLE THERMOSTAT (40° - 100° TEMPERATURE RANGE)					
09962102	E3055T2DWB	750 or 1500	5120	120	12.5
09962202	E3058T2DWB	900 or 1800	6143	120	15.0
09962502	F3052T2DWB	1000 or 2000	6826	208	8.3
09456902	F30522T2DWB	500 or 750 or 1000 or 1250 or 1500 or 1750 or 2250	7680	208	10.8
09962802	H3052T2DWB	750 or 1000 - 1500 or 2000	6826	208 / 240	8.3
09457202	H30522T2DWB	500 or 750 or 1000 or 1250 or 1500 or 1750 or 2250	7680	240	9.4
09963102	G3052T2DWB	2000	6826	277	7.2

### Accessories

MFG CATALOG NUMBER	MFG MODEL NUMBER	DESCRIPTION
09969402	305EX8	1" EXTENDER
09969302	305EX16	2" EXTENDER
09969202	305EX32	4" SURFACE MOUNT FRAME

Note: Please see Draft Barrier Heaters - General Product Information in catalog for custom color availability.