

Macurco™

BUILDING & HOME SOLUTIONS

Whether you are looking for gas detection for a security system, building automation or HVAC system, for personal safety or for monitoring specific gases in potentially hazardous environments, Macurco has a gas detector to meet your needs.



Gas Boiler Controller

The Gas Boiler Controller used in conjunction with Macurco Gas detectors is used to shut down boilers in the presence of gas. Using a single detector or up to four gas detectors the controller can control up to 8 dry contact outputs. These outputs are designed to shut down the boiler system upon the detection of carbon monoxide and/or combustible gases such as natural gas or propane. If the detectors are programmed in latching mode then utilizing the Gas Boiler Controller you can reset the power to disengage the latched relay. The Gas Boiler Controller has a green power light, a red alarm light, a boiler reset button, and an audible buzzer.



Gas Boiler Controller

Key Features

- Shutdown up to 8 boilers individually via expansion relays
- Customize up to 8 10A SPDT Relays (sets of 2)
- Customize up to 4 expansion relay boards
- 24VDC driver for horn/strobe
- Opaque Polycarbonate, NEMA 4X/6P (IP66/68)
- Audible Buzzer
- Output power supports up to 4 detectors
- 24V or 120V options

Applications

- Boiler Rooms



Gas Boiler Controller

Specifications

Size	9.8" x 8" x 4.5" (24.9 X 20.3 X 11.4 cm)
Weight	3 lbs.
Voltage/Current	24 VAC/VDC or 120VAC
Operating Temperature	32°F to 125°F (0°C to 52°C)
Ambient Humidity	0% to 95% RH non-condensing
Mounting	6 mounting holes
Buzzer	90 dBA at 1 ft
Status Indicators	Green Light – Powered Up Red Light – Alarm Condition
Outputs	Relay Expansion Board – 2 SPDT, 250VAC, 10 A Max (resistive) 4 expansion board capacity (8 total relays)
Settings	Jumpers
Enclosure	NEMA 4X/6P (IP66/68)
Warranty	Two year limited warranty

Model Options

Description	Model Number
24 Volts - 2 Relays	GBC-24-2
24 Volts - 4 Relays	GBC-24-4
24 Volts - 6 Relays	GBC-24-6
24 Volts - 8 Relays	GBC-24-8
120 Volts - 2 Relays	GBC-120-2
120 Volts - 4 Relays	GBC-120-4
120 Volts - 6 Relays	GBC-120-6
120 Volts - 8 Relays	GBC-120-8

Accessories

Description	Model Number
CO Detector	CM-6
LEL Detector	GD-6
Horn and Strobe	HS-A, HS-B, HS-C, HS-R
Emergency Power Off	E Stop

Wiring Diagrams

Using Both Sensor Inputs

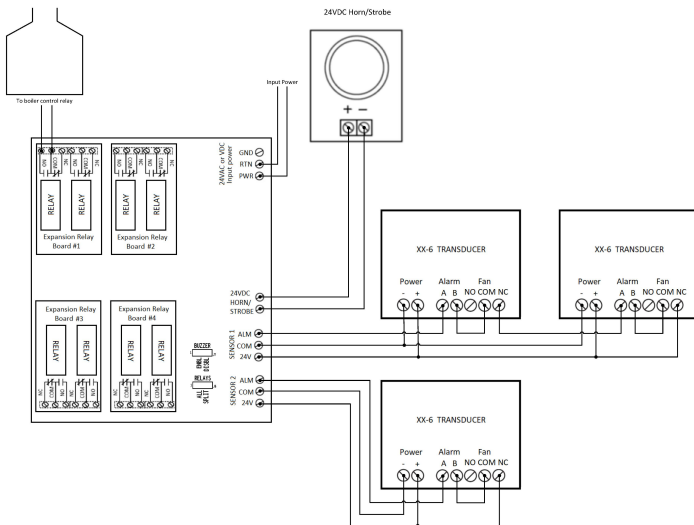

Only Using Sensor Input 1

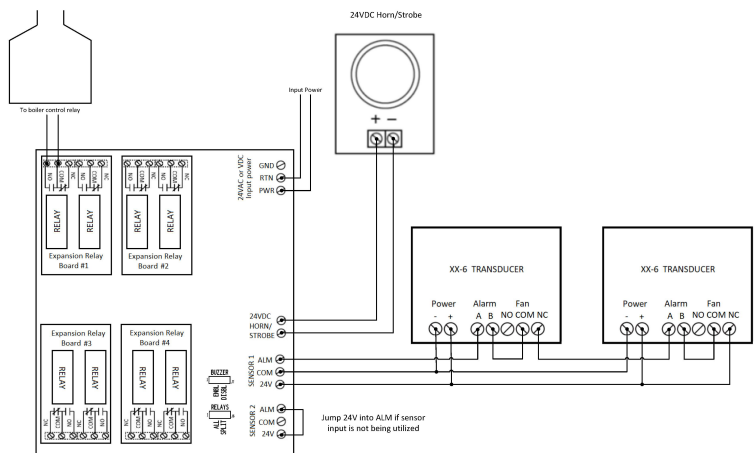

Since 1972 Macurco has been providing gas detection solutions for various applications. Macurco provides the highest quality gas detection solutions to customers worldwide.



Macurco Gas Detection
1504 W. 51st Street
Sioux Falls, SD 57105

Phone: 1-877-367-7891

Website: www.macurco.com

Email: info@macurco.com