

JOB NAME \_\_\_\_\_  
 ARCHITECT \_\_\_\_\_  
 ENGINEER \_\_\_\_\_  
 CONTRACTOR \_\_\_\_\_  
 LOCATION \_\_\_\_\_

**SUBMITTAL SHEET**  
 Form Number GRS0300.4 Effective Date 1/08  
 Replaces Form GRS0300.3

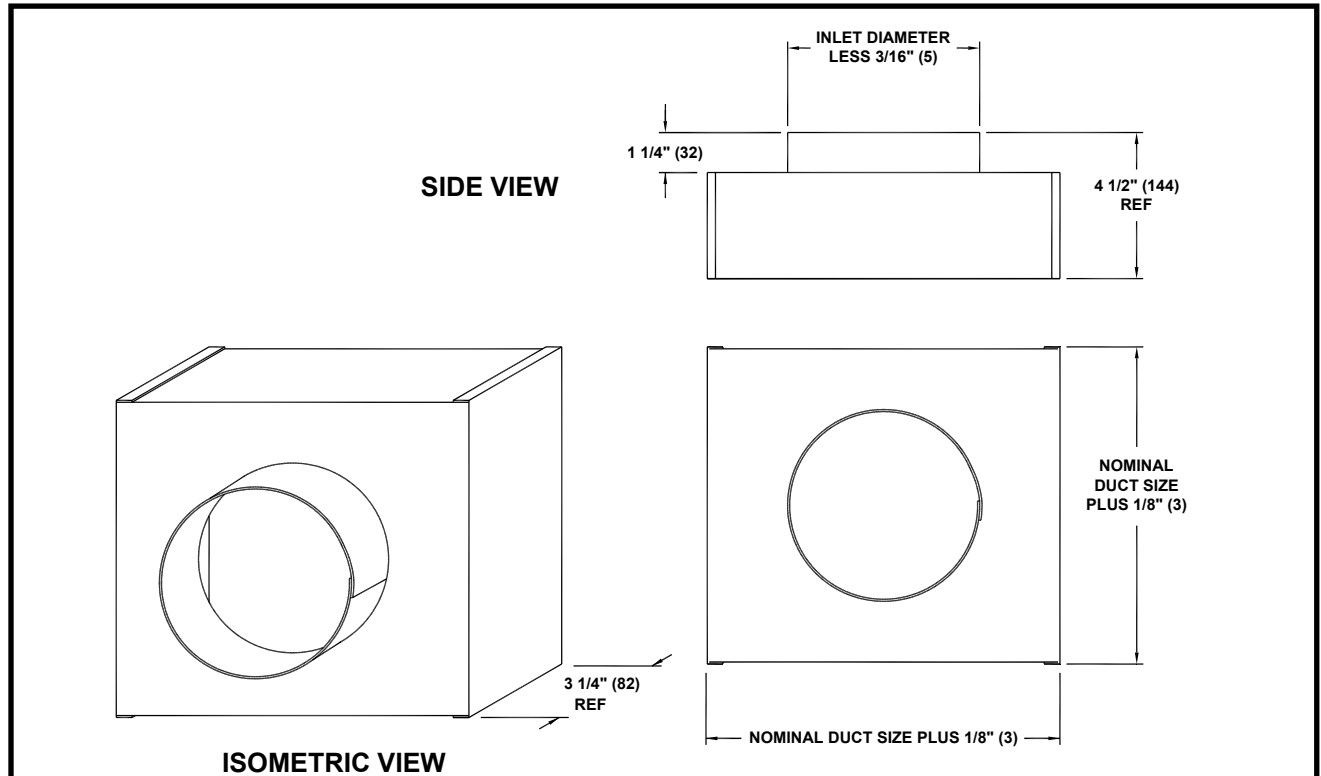

**SRAC325**  
**STEEL SQUARE TO ROUND ADAPTER**



		Inlet Diameters													
		4" (102)	5" (127)	6" (152)	7" (178)	8" (203)	9" (229)	10" (254)	12" (305)	14" (356)	15" (381)	16" (406)	18" (457)	20" (508)	22" (559)
Square Duct Sizes	6x6 (152x152)	•	•	•											
	8x8 (203x203)		•	•	•	•									
	9x9 (229x229)			•	•	•	•								
	10x10 (254x254)				•	•	•	•							
	12x12 (305x305)				•	•	•	•	•						
	14x14 (356x356)				•	•	•		•	•	•				
	15x15 (381x381)				•	•	•		•	•	•	•			
	16x16 (406x406)				•	•	•		•	•	•		•		
	18x18 (457x457)				•	•	•		•	•	•		•	•	
	20x20 (508x508)				•	•	•		•	•	•		•	•	•
	21x21 (533x533)				•	•	•		•	•	•		•	•	•
	22x22 (559x559)				•	•	•		•	•	•		•	•	•

**NOTES :**

- STANDARD CONSTRUCTION IS 24 GA. GALVANIZED STEEL.
- UNIT SHIPS SEPARATELY.
- THE SRAC325 IS DESIGNED FOR VARIOUS SQUARE NECK GRILLES, REGISTERS AND DIFFUSERS.
- MILL FINISH STANDARD.

**DIMENSIONS ARE GIVEN AS INCHES (MM)**