

7-Day Programmable Wall Heater LPW ECO2S Pro Series

Model Code:
LPW 20 45-ECO2S-PRO-WD
A B C D E F

- A: Series
- B: 12 - 120V 24 - 240V 20 - 208V
- C: Watts 45-(2500-4500W)
27-(1500-2750W)
- D: ECO2S 2-Stage Electronic Control
- E: ECO PRO Controller: 7-Day Programmable
Thermostat + Remote Temp Sensor
- F: White Dove



- Smart ECO2S design
- 7-Day programmable heating schedule
- 2-Stage heating
- Eco Pro Controller remote thermostat w/ temperature sensor
- Integrated BMS lockout circuit
- Auto Memory Feature: returns units to last settings after power outage
- Pic-A-Watt® element
- Multiple wattage options
- Compatible w/Optional wired or wireless RF window/door /Occupancy sensors
- Patented Smart Limit Protection®
- Whisper quiet squirrel cage blower
- Timer & Summer Fan Only Modes
- Solid riveted construction for consistent, long-term durability
- Display Lock Feature: for high traffic areas
- Bedroom "Environment" Feature: turns off the display when not in use
- Available in (4) new designer finishes
- 5-Year limited warranty

The LPW ECO2S Pro Series Electronic 2-Stage Smart Wall Heater w/ 7-Day Programmable RF Wireless Thermostat.

King's latest innovation, the LPW ECO2S PRO Smart Wall Heater, delivers next-level comfort control with the powerful ECO PRO Remote Thermostat, featuring a 7-day programmable heating schedule that puts personalized comfort right at your fingertips.

This advanced scheduling function allows users to set different heating profiles for each day of the week, aligning comfort with daily routines while optimizing energy efficiency. At the core of the system is the original ECO2S electronic controller, which ensures consistent warmth by minimizing temperature swings. During colder periods, it delivers full power to heat the room quickly, then automatically reduces wattage to maintain the set temperature while saving energy. The ECO PRO Remote Thermostat, equipped with an integrated temperature sensor, can be placed anywhere in the room to eliminate cold spots and ensure precise temperature control exactly where it's needed. Additional smart features include summer fan-only and timer modes, remote temperature adjustments, and King's exclusive dual Pic-A-Watt heating elements, allowing installers to easily select the ideal wattage during setup. An integrated BMS lockout circuit enables seamless integration with Building Management Systems, preventing the heater from operating during cooling cycles. The LPW ECO2S PRO is also compatible with optional wired or wireless RF window/door and occupancy sensors, automatically setting back temperatures when windows are open or when the room is unoccupied. With its intuitive programming, energy-saving design, and advanced sensing capabilities, the LPW ECO2S PRO redefines smart electric heating with comfort that adapts to your life.

Meet the ECO PRO CONTROLLER: 7-Day Programmable Thermostat with Remote Temperature Sensing



Eco Pro Controller

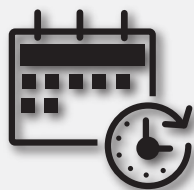

7-Day Programmable Heating Schedule



Balanced Heat Throughout the Space



Comfort, Right Where You Want It



Remote Temperature Sensing

7-Day Programmable Wall Heater LPW ECO2S Pro Series

“Complete” Stock Models For other color grill options replace -W suffix with -SN for Satin Nickel, -AD for Almondine, -OB for Oiled Bronze Grill

BASE MODEL	UPC	PRO CONTROLLER	VOLTS	COLOR	WATTS	AMPS	SHIP WEIGHT lbs
LPW1227-ECO2S-PRO-WD	70401	Included	120	White Dove	1500•1750•2000•2250•2500•2750	10.4 - 22.9	19.0
LPW2045-ECO2S-PRO-WD	70402	Included	208	White Dove	2500•3000•3500•4000•4500	10.8 - 21.6	19.0
LPW2445-ECO2S-PRO-WD	70403	Included	240/208*	White Dove	2500•3000•3500•4000•4500	9.4 - 18.8	19.0

*Dual rated heaters will draw 13% less amps and 25% less wattage when operated at 208V.

DESIGNER COLORS AVAILABLE



Factory Installed Options

ADD SUFFIX	DESCRIPTION
-WD	White Dove Color
-SN	Satin Nickel Color
-AD	Almondine Color
-OB	Oiled Bronze Color

NOTE: Not all configurations listed above are A stock code items. Refer to price book for the Stock code

Optional Control Accessories

MODEL	UPC	DESCRIPTION	SHIP WEIGHT lbs
ECO-PRO-RF-PIR-SENSOR	70422	Optional, RF Battery Powered PIR Occupancy Sensor for ECO Models	0.1
ECO-PRO-RF-WINDOW-SENSOR	70423	Optional, RF Battery Powered PIR Window or Door Sensor for ECO Models	0.2
ECO-PRO-CONTROLLER	70421	Replacement Pro Controller - 7-Day Programmable Thermostat/Remote Sensor/Remote	0.2

-All A'la Carte orders come in Kraft box packaging

Accessories

MODEL	UPC	DESCRIPTION	SHIP WEIGHT lbs
LPWSMF-WD	32620	LPW, Surface Mount Frame, White Dove Color	2.0
LPWSMF-AD	32623	LPW, Surface Mount Frame, Almondine Color	2.0
LPWSMF-SN	32621	LPW, Surface Mount Frame, Satin Nickel Color	2.0
LPWSMF-OB	32622	LPW, Surface Mount Frame, Oiled bronze Color	2.0

-All A'la Carte orders come in Kraft box packaging

Expand Your Control with Optional Wireless Sensors For Automatic Temperature Setback

eco2s+ PRO CONTROL

ECO Pro Controller
Programmable 7-Day Heating Schedule & Remote Temperature Sensor

+

RF Occupancy Sensor (optional)

Room Unoccupied
Setback Options: 45°F, 55°F, 60°F or 65°

or

RF Window/Door Sensor (optional)

Open Window or Door
Setback Options: 40°F, 45°F, 50°F or 55°

7-Day Programmable Wall Heater LPW ECO2S Pro Series

Dimensional Data

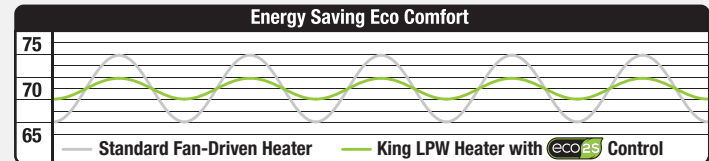
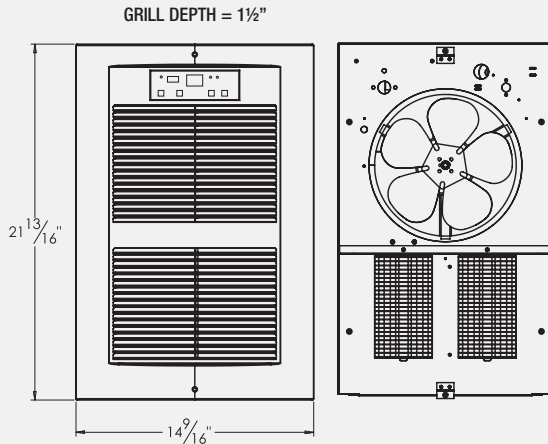
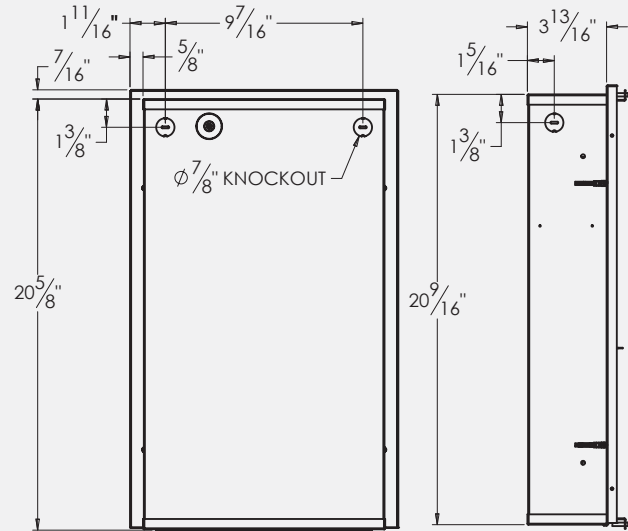
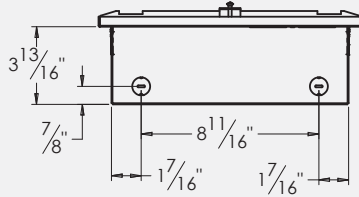

*Reduces temperature swings

Engineering Specifications

Contractor shall supply and install LPW-ECO2S Pro Series in-wall mounted forced-air electric heaters manufactured by King Electrical Mfg. Company, of the wattage and voltage as indicated on the plans.

Ratings: Heaters shall be available in wattages of 1500 to 2750 at 120 or 2500-4500 at 208, or 240 Volts

Motor: Heavy-duty, cast iron, unit bearing, permanently lubricated with 20cc oil reservoir, 1440 RPM. Enclosed impedance protected with intake air cooling motor for increased bearing life.

Fan: High efficiency, dynamically balanced 5-blade aluminum fan. 185 CFM.

ECO2S Electronic Control: Up, Down temperature mode. Automatic 2-Stage heating (High & ECO Modes). Start/Stop. Fan Only and Timer (1-9hours) Modes. Standard on all heaters. The control voltage is equal to the line voltage.

ECO2S PRO Remote 7-Day Thermostat: RF 2.4G RF Wireless Protocol. 7-day programmable touch sensitive thermostats with an integrated temperature sensor. Enables custom 7-day programmable heating schedules, functions as both a remote temperature sensor and a handheld remote control for heater operation.

Auto Memory Feature: Returns Unit To Last Settings After Power Outage.

Elements: Element assemblies shall consist of three steel sheathed heating tubes in a furnace-brazed, plate-finned, block design. Each sheathed tube shall contain coiled Ni-Chrome wire, embedded in an insulator of Magnesium Oxide. The element assembly shall provide up to five (5) possible wattage configurations available for selection during field installation. The use of external resistors,

cdiodes, or other weak links to obtain multiple wattages will not be accepted.

Thermal Overload: Heaters shall be equipped with King's patented thermal overload Smart Limit Protection®, which disconnects elements and motor in the event normal operating temperatures are exceeded. If thermal overload trips due to abnormal operating temperatures, thermal overload shall remain open until manually reset by turning the heater off for 15 minutes.

Fan / Heat / Off: Electronic Controller provides heating and summer fan-only operation.

Wall-Can: 20 gauge electro-galvanized steel with factory installed ground-wire. Minimum 4" clearance to floors and 6" to sidewalls. Components are assembled using solid mechanical rivets rather than spot welding, eliminating heat-affected zones and hidden weld defects. Riveted joints are fully visible and inspectable, providing consistent structural integrity under vibration and thermal cycling. Zero clearance to combustibles in the wall. Recommended 10" clearance to floors and 16" to sidewalls.

Grill: The grill shall be a louvered, one-piece curved front design with rounded edges on all four sides. The grill shall be epoxy powder-coated in white dove, almondine, satin nickel or oiled bronze.

Options: Wired for remote thermostat, retrofit grill, and surface wall-box.

Approvals: (E41422 cULus)