

# INSTALLATION AND MAINTENANCE



## KBU PlatinumX BMS Series Compact Plenum Heaters



DANGER

---

ELECTRIC SHOCK OR FIRE HAZARD

READ ALL WIRE SIZING, VOLTAGE REQUIREMENTS AND SAFETY DATA TO  
 AVOID PROPERTY DAMAGE AND PERSONAL INJURY

**ECO PRO Controller - Optional Accessory For BMS Models**

KBU PlatinumX BMS plenum rated heaters are to be operated at **voltage listed on the rating label**. It is important to verify the power supply voltage is the same as the nameplate voltage of the heater. Connecting the heater to an improper voltage or failure to follow the procedures as outlined in this manual can result in damage to the heater and void the warranty. Disconnect all power from the heater at the main service panel before attempting to install or service this unit. All electrical wiring must conform to local electrical codes. Heater circuit must be properly protected.

WARNING

**READ CAREFULLY** - Use the heater only as described in this manual. Any other use is not recommended and could result in fire, electric shock, and personal injury. Following these instructions will prevent difficulties that might occur during the installation and use of the heater. Please study the instructions first, as they may save considerable time and trouble during use, in addition to providing important safety information. Make sure to save these instructions for future use.

- WARNING** To prevent a possible electrical shock, disconnect all power coming to heater at main service panel before wiring or servicing.
- WARNING** All wiring must be in accordance with the National Electrical Code (Canadian Electrical Code in Canada) and all applicable local codes. The heater must be grounded as a precaution against electrical shock. Supply wiring must be copper and suitable for at least 75° C.
- WARNING** Verify power supply and control voltages coming to the heater match the ratings printed on the heater nameplate before energizing.
- WARNING** Heater must be installed so the minimum clearances shown in Specifications table are maintained.
- WARNING** This heater is NOT suitable for use in hazardous locations as described by the National Fire Protection Association (NFPA). This heater has hot and arcing or sparking parts inside. DO NOT use in areas where gasoline, paint or other flammable liquids are used or stored.
- WARNING** The mounting structure and anchoring hardware **MUST BE** capable of reliably supporting the weight of the heater plus mounting bracket if used. Refer to specifications table for heater weight.
- WARNING** Heater air flow **MUST** be directed parallel to or away from adjacent walls.
- WARNING** To prevent a possible fire, DO NOT block air intakes or exhaust openings in any manner. DO NOT allow foreign objects to enter grill openings as this may cause electric shock, fire or damage to heater.
- WARNING** Do not connect any ducting to the supply or exhaust of the heater. Product is not designed to be connected to duct.



**CAUTION—RISK OF ELECTRIC SHOCK  
DO NOT OPEN HEATER SHELL**



# KBU PLATINUMX BMS INSTALLATION

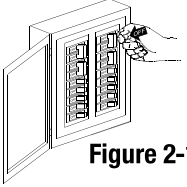

**CAUTION!**  
Turn OFF all electrical power to install heater

Figure 2-1



## Selecting A Location For Your Heater:

The KBU is designed to be placed in areas that are typically hard to reach with your conventional heating sources. This plenum-rated heater is approved for installation in concealed spaces (between finished ceilings and drop ceilings, plenum space, or inside a plenum).

It may be installed in areas that are not readily available to access and in certain areas that require freeze protection. The unit can be installed on any ceiling as long as front and rear intake clearances are met.

The direction of air flow should not be restricted by machinery, beams, columns or partitions, etc., and the air flow should be parallel to exposed walls rather than blowing directly at them.

Small areas can be heated by one unit heater. Large rooms require multi-unit installations. Number and capacity of units will be determined by volume of building and square footage of floor area to be heated.

When more than one heater is used in an area, the heaters should be arranged so that the air discharge of each heater supports the air flow of the others to provide best circulation of warm air.

(see air flow chart)

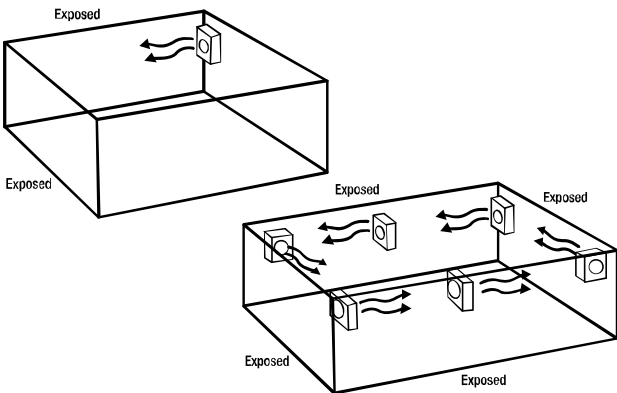

## Unpack & Inspect Your New Heater

Remove heater from the box and inspect it for any damage. Verify you have received the low clearance ceiling mount brackets.

## Tools Needed

You will need the following tools to install your unit heater:

- Screwdriver - (Square Head)
- Wire Cutters
- Pliers
- Adjustable Wrench
- Electric Drill

## Hardware Needed For Installation

You will also need the following hardware, which can be purchased from your local hardware store or electrical supply house:

- adequate gauge and length of wire for your application
- proper size fuses or breakers to handle amperage
- proper wire connectors for your application
- fasteners appropriate for application that are strong enough to hold unit

For certain applications conduit may be required. Check local electrical codes. Also, if you run the wiring in conduit and wish to be able to turn the heater, be sure to purchase enough flexible conduit to allow the heater to be turned.

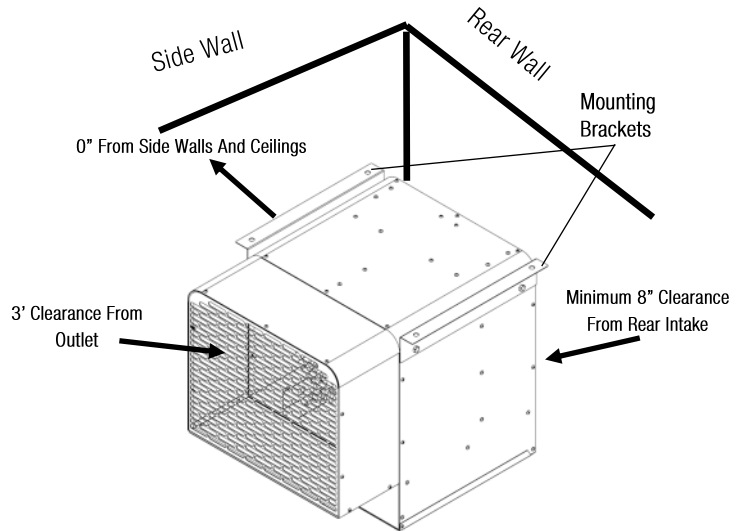

## Mounting Height

When mounting on the ceiling, the KBU requires 18 inches of clearance below the unit to access to the electrical compartment. A hinged panel secured by a screw will swing down, revealing the electrical compartment.

## Distance From Vertical and Side Walls

The KBU can be installed with zero clearance to all side walls and ceilings. Maintain proper rear-intake and outlet clearances.

# KBU PLATINUMX BMS INSTALLATION

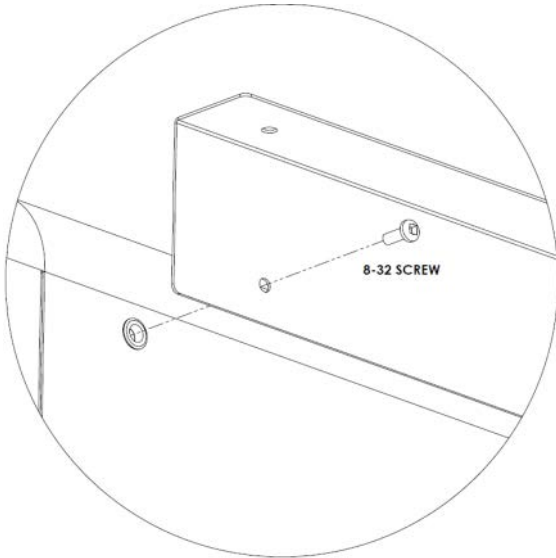

## Installing the Low Profile Ceiling Brackets to the Heater

The Plenum Heater comes with 2 L-Shaped plates that will attach to each side of the KBU.

Use 8-32 screws to attach the plates onto both sides of the KBU so that the mounting holes are at the top of the fixture, overhanging the sides. The long side of the bracket will be attaching directly into the side of the KBU heater. The shorter end of the bracket will hang outward and across the top. If installed correctly, the top of the bracket should be flush with the top of the KBU heater.

Using appropriately rated screws to hold the unit, you can now mount the KBU onto the ceiling using the 4 holes overhanging the left and right side. Reference the figure below for recommended mounting hardware and installation.

Reference the weights of each unit when selecting proper mounting hardware. Mounting screws should hold at least 3x the weight of the unit.

## Installing the Ceiling Mounting Bracket

The heater can be installed on a ceiling using 2 low-profile mounting brackets that are installed onto the heater. Locate a stud in the ceiling to securely fasten the low-profile mounting brackets to the supporting surface with 4 x 1/4"x20 fasteners strong enough to hold the unit, at least 1-1/4" in length.

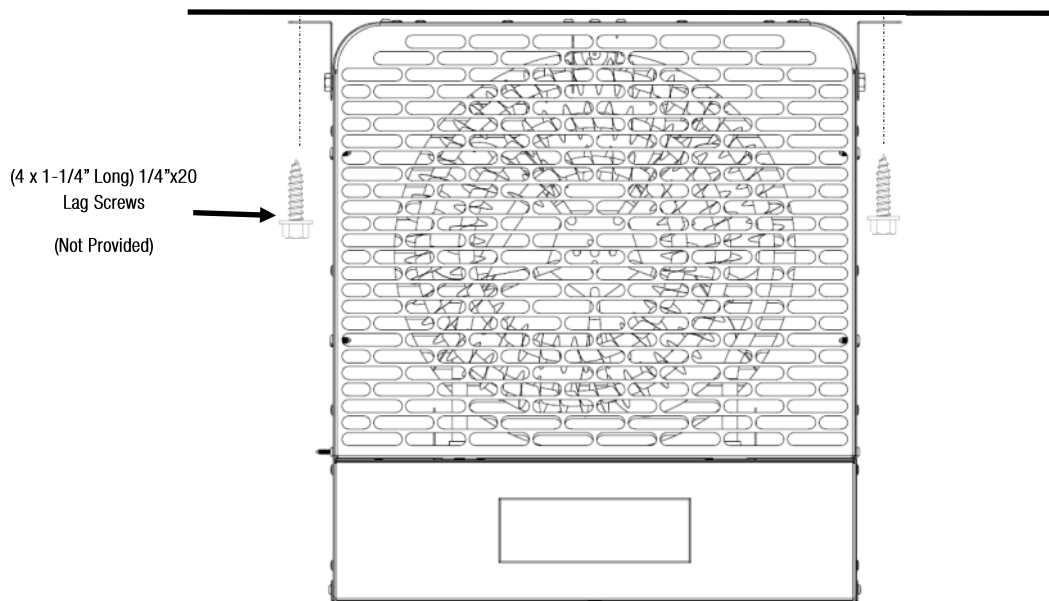

Ceiling Mount

# KBU PLATINUMX BMS WIRING

DANGER

ELECTRIC SHOCK OR FIRE HAZARD

LINE VOLTAGE IS PRESENT ON SOME OF THE TERMINALS ON THE CONTROL TERMINAL BOARD. ALWAYS DISCONNECT THE POWER FROM THE HEATER BEFORE MAKING ANY CONNECTIONS TO THE CONTROL BOARD TO PREVENT ELECTRIC SHOCK HAZARD.

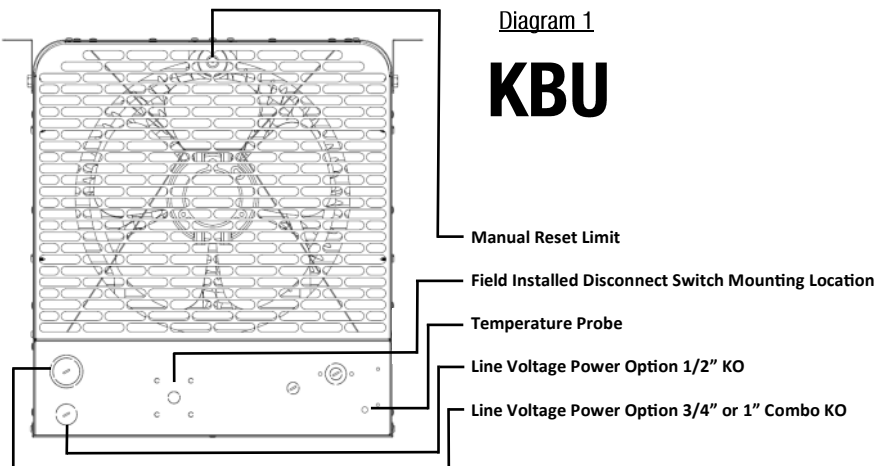

Diagram 1

## KBU

1. Connect heater to the voltage, and frequency specified on the nameplate.
2. Field wiring must be properly sized to carry the amperage of the heater in accordance with the NEC.
3. The electrical wiring compartment access door is hinged and has a screw on the bottom. Remove the screw to gain access.
4. Electrical knockouts are provided on the back of the heater close to the power contactor. Use the diameter that fits the required conduit fitting size. **See diagram 1 for more details.**
5. A ground terminal is provided. The ground wire should be connected before other connections are made.
6. The power contactor is equipped with lugs to accept the power supply wire. Copper wire must be rated at 600 V and 75° C for the heater branch circuit.
7. Each heater has a wiring diagram affixed to the inside of the access door. Consult diagram before making any field connections.
8. Single or three-phase power connections may be used with heater models marked -3MP. These units are factory wired for three phase. If these heaters are needed for use with single-phased power, reconnect the wires as indicated in the wiring diagram attached to the heater. Reference the "Notes" section on the wiring diagram.

**Note:** The mounting location for an optional field-installed disconnect switch (ordered separately) is shown above.

We're Here to Help!

For any difficulties installing or operating this product

Call Us Toll Free at:

1-800-603-5464 Option 2

7:00 am -3:30 pm PST Mon-Fri

Visit [king-electric.com](http://king-electric.com)

or email us at [tech@king-electric.com](mailto:tech@king-electric.com)

# OPERATING INSTRUCTIONS



## Operation

1. Push the  button, the heater will turn on and heat to the default setting of 72°F.
2. Once the room temperature reaches the set point, the heat elements will turn off, followed by a 3 minute fan delay period to exhaust excess heat from the case. Afterwards the unit will turn off.
3. In normal operation the display will show the current room temperature.

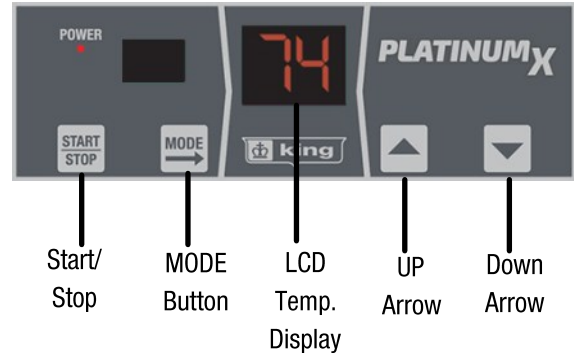
PlatinumX BMS / PRO Control Panel





## Room Temperature Selection

- During operation, push  or  arrow buttons to set the temperature from 40°F-95°F, Hold down the UP or DOWN arrow to speed up the selection process. The LCD will go back to display room temperature after 5 seconds.



## Timer Mode Selection

- During operation, press the  button 1 time, the display window will show the timer mode setup. Push  or  to set Timer from 1 hour—9 hours.

## Fan Only Mode Selection

- During operation, press the  button 2 times, the display window will show [ H ] Heat Mode or [ F ] Fan Only Mode.

Push  or  to switch between Fan Only and Heat modes.

## DISPLAY DIP SWITCH SETTINGS



BMS Model Defaults

### DIP SWITCH 1

OFF = EXTERNAL SENSOR or ECO PRO CONTROLLER  
ON = LOCAL SENSOR CONTROL (BMS DEFAULT)

### DIP SWITCH 2

OFF = 24V REMOTE STAT (CUSTOMER PROVIDED)  
ON = LOCAL STAT (CONTROL SETTING BY DISPLAY) (BMS DEFAULT)

### DIP SWITCH 3

OFF = WIRED DOOR/WINDOW/PIR SENSOR CONNECTED  
ON with A+B JUMPER INSTALLED = BMS LOCKOUT DISABLED (BMS DEFAULT)  
ON with A+B JUMPER REMOVED = BMS LOCKOUT ACTIVE

### DIP SWITCH 4

OFF = PIR OCCUPANCY SENSOR  
ON = WINDOW/DOOR SENSOR (BMS DEFAULT)

# OPERATING INSTRUCTIONS CONTINUED

## Display Lock Feature





Display Lock is designed for high traffic areas and deactivates the heater display buttons to prevent unwanted temperature adjustments. However settings can still be adjusted through the remote control.

- During operation, press the  button and HOLD for 5 seconds to set the display lock. [ L ] will appear on the display temporarily if a user attempts to make a temperature adjustment. While in Display Lock, heater can be adjusted using remote control.

## Setting “Environment” Mode

Two Environment Options: **Standard [ SF ]** and **Bedroom [ BE ]**.

Bedroom Mode turns off the display after 30 seconds for people using this heater in a light sensitive environment. Once any button is pressed the display turns back on.

- During operation, press the  and  buttons for 3 seconds. Then press  or  to select

Standard Mode [ SF ] or Bedroom Mode [ BE ]

## Factory Reset







- During operation, press and HOLD the  button for 5 seconds to reset to the factory settings. [ FA ] will flash on the display.

## Sensor Error Code

- During operation, if the display shows [ E1 ] that indicates an issue with the sensor and the sensor needs to be replaced. Contact customer support for assistance.

## Setting Differential Value

The differential or gap affects how often the heater cycles. The lower the differential setting, the more the heater will cycle. If heater cycles too often, raise the differential setting to a higher degree.

- Press the  and HOLD the  and  buttons for 5 seconds. The display will show the previously set  differential. Press  or  to adjust the differential value between -0 to -5.

PlatinumX BMS / PRO Control Panel

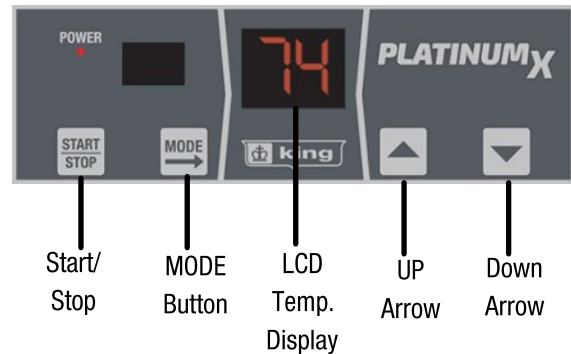

# PLATINUMX

## DISPLAY DIP SWITCH SETTINGS



BMS Model Defaults

### DIP SWITCH 1

OFF = EXTERNAL SENSOR or ECO PRO CONTROLLER  
ON = LOCAL SENSOR CONTROL (BMS DEFAULT)

### DIP SWITCH 2

OFF = 24V REMOTE STAT (CUSTOMER PROVIDED)  
ON = LOCAL STAT (CONTROL SETTING BY DISPLAY) (BMS DEFAULT)

### DIP SWITCH 3

OFF = WIRED DOOR/WINDOW/PIR SENSOR CONNECTED  
ON with A+B JUMPER INSTALLED = BMS LOCKOUT DISABLED (BMS DEFAULT)

ON with A+B JUMPER REMOVED = BMS LOCKOUT ACTIVE

### DIP SWITCH 4

OFF = PIR OCCUPANCY SENSOR  
ON = WINDOW/DOOR SENSOR (BMS DEFAULT)

# BMS LOCKOUT CIRCUIT (OPTIONAL)

KBU PlatinumX BMS models features onboard terminals (Figure A ) that allow connection to a Building Management System (BMS) to disconnect the heat output remotely when the A/C system is running.

When BMS takes control, heater functions will not work, the touch screen is locked, [BL] light appears on the heater display.

When BMS releases control, heater functions are available, heater resumes operating at previously programmed settings.

Refer to BMS system's Operations Manual for programming options and details.

See below for additional info.

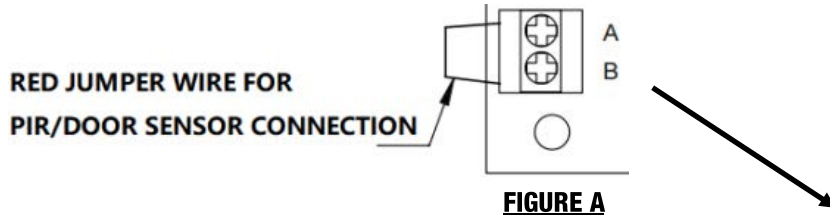

NOTE: DO NOT REMOVE RED JUMPER UNLESS BMS SYSTEM CONTROL IS BEING USED.

## CONNECTING A BUILDING MANAGEMENT SYSTEM (BMS) TO DISCONNECT HEATER OUTPUT REMOTELY

### Step 1: Wire Building Management System (BMS) To Heater

To utilize the BMS Lockout capabilities remove the red jumper wire between terminals A and B on the control terminal board. (See Figure A). Connect two wires from a dry contact (no voltage) of the BMS system to terminals A and B.

NOTE: DO NOT REMOVE THE RED JUMPER UNLESS CONTROL BY A BUILDING MANAGEMENT SYSTEM IS BEING USED.

### Step 2: Dip Switch Selection: On back of the Control Display, switch Dip Switch #3 to ON Position to activate BMS Lockout capabilities.

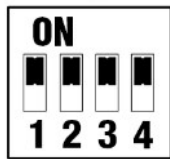

BMS Models Settings

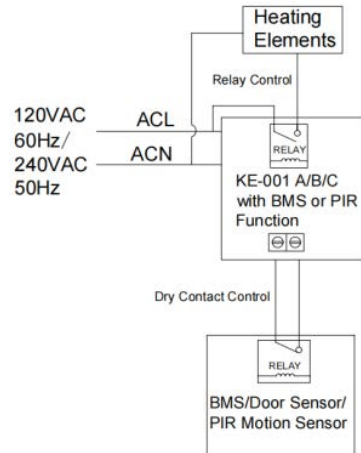

When BMS contacts are open, System is OFF regardless of room temp.

Control Display shows [BL]

Heater Display – Heater Locked Out



# WIRED AUXILIARY CONTROL OPTIONS (OPTIONAL)

KBU PlatinumX BMS models features onboard terminals (Figure A) that allow a wired auxiliary window/door sensor or PIR Occupancy Sensor for automatic triggering of a setback or off state when the contacts open for Window/Door sensor or close for the PIR Occupancy Sensor.



FIGURE A

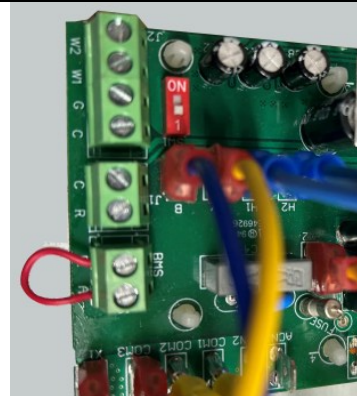

## CONNECTING A WIRED WINDOW/DOOR SENSOR or OCCUPANCY SENSOR TO THE SYSTEM

### Step 1: Wire Sensor To Heater

To utilize the Window/Door or PIR Occupancy Sensor capabilities remove the red jumper wire between terminals A and B on the control terminal board. (See Figure A). Connect two wires from a dry contact (no voltage) of the PIR motion sensor or door sensor to terminals A and B.

### Step 2:

#### Dip Switch Selection (Window/Door Sensor):

Switch Dip Switch #3 to OFF position to activate Window/Door or PIR Occupancy capabilities.  
Switch Dip Switch #4 to ON position to select Window/Door Sensor

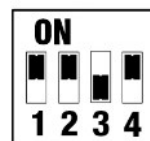

BMS Models Settings - Window/Door Sensor

#### Dip Switch Selection (PIR Occupancy Sensor):

Switch Dip Switch #3 to OFF Position to activate Window/Door or PIR Occupancy capabilities.  
Switch Dip Switch #4 to OFF position to select PIR Occupancy Sensor.

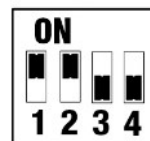

BMS Models Settings - PIR Occupancy Sensor

### Step 3: Select Environment Mode Option

When paired with an optional Window/Door or PIR Occupancy sensor there are two environmental modes to choose from when the sensor contacts open/close: Freeze Protection [FP] and OFF [OF].

Press the and HOLD the and buttons on the Control Display for 3 seconds.

Then Press or to select Freeze Protection or OFF mode.

#### Freeze Protection Mode:

When window/door contact is open or occupancy sensor contact is closed, heater sets back the set temp to 40F.

Control Display shows "FP".

#### OFF Mode:

When window/door contact is open or occupancy sensor contact is closed, System is OFF regardless of room temp.

Control Display shows "OF" Pro Controller display shows "OFF".

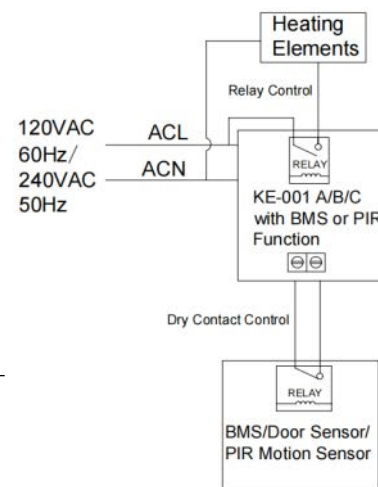

# CONNECTION OF OPTIONAL 24V REMOTE THERMOSTAT

## Controlling PlatinumX BMS with a Remote 24V Thermostat

KBU PlatinumX BMS heaters come standard with the provisions to connect any 24V remote wall thermostat, for remote temperature sensing and control. Provides silent operation control for use with a 24 Volt Thermostat. Follow steps below for setup and to select Sigle Stage or Two Stage Con-

### Step 1:

Dip Switch Selection On Display For Remote Thermostat—

Local or Remote Thermostat (Figure 1)

The # 2 dip switch on the back of the display is used for selecting between the onboard thermostat control and the optional remote wall thermostat control.

Set dip switch 2 to the OFF position to switch to 24V Remote Thermostat Control

### Step 2:

Dip Switch Selection On Controller PCB—1-Stage or 2-Stage Thermostat (Figure 2)

Refer to the thermostat operating instructions to determine if the thermostat is a single stage or two stage thermostat.

Select the dip switch setting required.

For 2-Stage Heating > Dip Switch = OFF

For 1-Stage Heating > Dip Switch = ON

### Step 3:

Wiring 24V Remote Thermostat to KBU Platinum (Figure 3)

Following thermostat manufacturer's instructions.

### 24V Remote Thermostat

### Local Thermostat (Default)

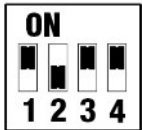

Dip switch #2:  
Off = Remote 24V  
Thermostat Control



Dip switch #2:  
On = Local Thermostat  
Control (default)

(BMS Models Settings Shown)

Figure 1: Back of Display



(BMS Models factory default shown)

Figure 2: Controller PCB



## Figure 3: Wiring Schematic Overview

### 1 DISPLAY (107774)

DIP SWITCH 1

OFF = EXTERNAL SENSOR or  
ECO PRO CONTROL (102806 or  
ECO-PRO-CONTROLLER)

ON = LOCAL SENSOR CONTROL  
(DEFAULT)

DIP SWITCH 2

OFF= REMOTE STAT (CUSTOMER  
PROVIDED)

ON = LOCAL STAT (CONTROL  
SETTING BY DISPLAY) (DEFAULT)  
CONTROL BOARD (107773)

DIP SWITCH 3

OFF= WIRED DOOR/WINDOW/PIR  
SENSOR CONNECTED

### 2 ON with A+B JUMPER INSTALLED = BMS LOCKOUT DISABLED (DEFAULT)

ON with A+B JUMPER REMOVED =  
BMS LOCKOUT ACTIVE

DIP SWITCH 4

OFF= PIR OCCUPANCY SENSOR

ON=WINDOW/DOOR SENSOR  
(DEFAULT)

### OPTIONAL 24V REMOTE THERMOSTAT (FIELD INSTALLED)

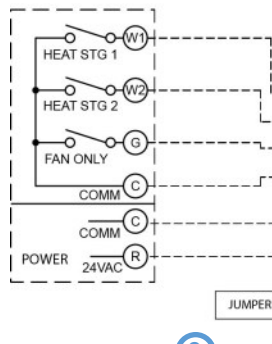

### DIP SWITCH SW1 3

ON = SINGLE STAGE REMOTE  
STAT (DEFAULT)

OFF = TWO STAGE REMOTE  
STAT

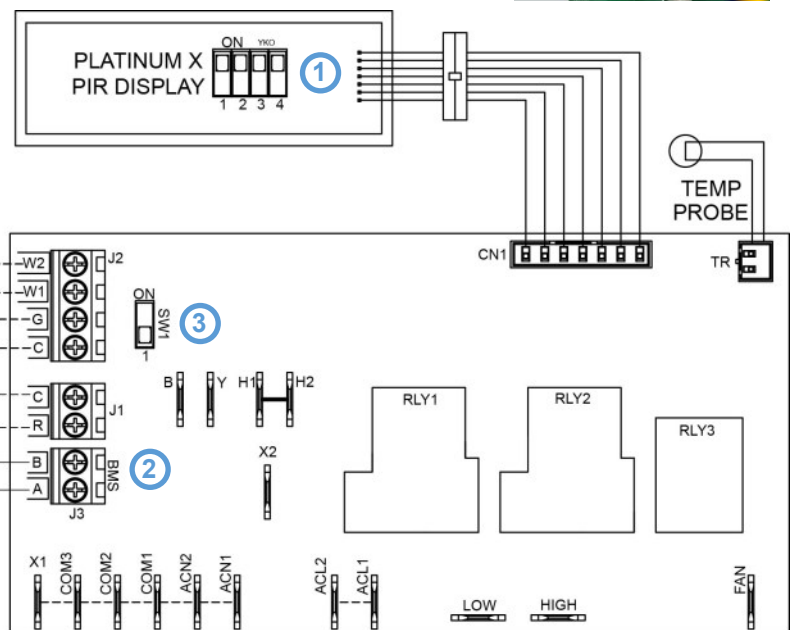

# CONNECTION OF OPTIONAL NEST LEARNING THERMOSTAT



To connect a Nest Learning to PlatinumX, you will need to run multi-conductor thermostat wire between the Nest Thermostat and the PlatinumX terminal board per the wiring diagram below. Thermostat wire is a class 2 power-limited circuit cable for use in thermostat control applications.

Nest King PlatinumX  
G ----- G, FAN ONLY

## Conventional 1 Stage Heating **PLATINUMX**

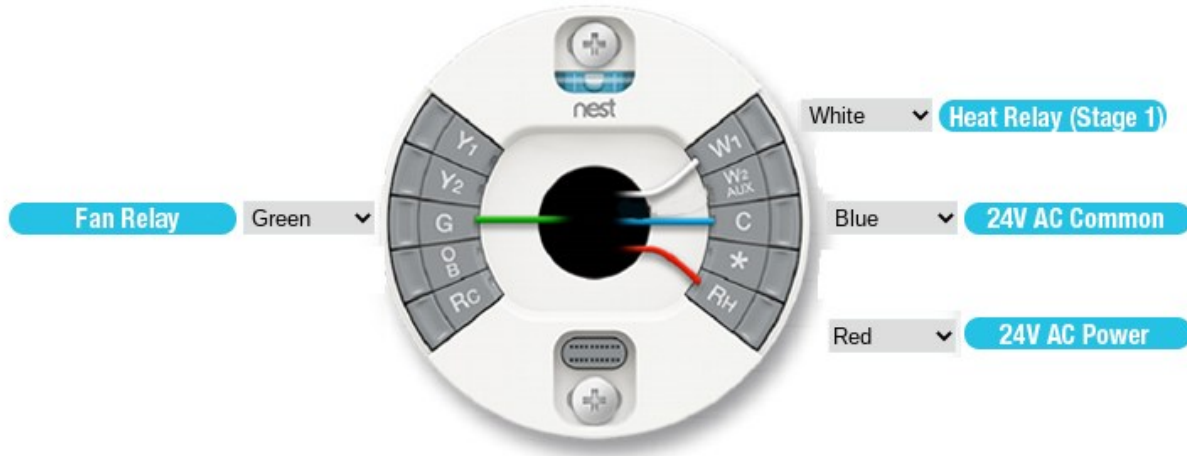

NOTES:

- Y1,Y2,OB,RC, & (\*) are for Heat Pumps and Air Conditioning, NOT USED on KING HEATERS. The C wire keeps the Nest battery power charged.

# CONNECTION OF OPTIONAL NEST BASIC / E THERMOSTAT



To connect a Nest / Nest E Series to PlatinumX, you will need to run multi-conductor thermostat wire between the Nest Learning Thermostat and the PlatinumX terminal board per the wiring diagram below. Thermostat wire is a class 2 power-limited circuit cable for use in thermostat control applications.

Nest King PlatinumX  
G ----- G, FAN ONLY  
W1 ----- W1, STAGE 1 HEAT  
R ----- R, POWER (24VAC)  
C ----- C, COMMON

## Conventional 1 Stage Heating **PLATINUMX**

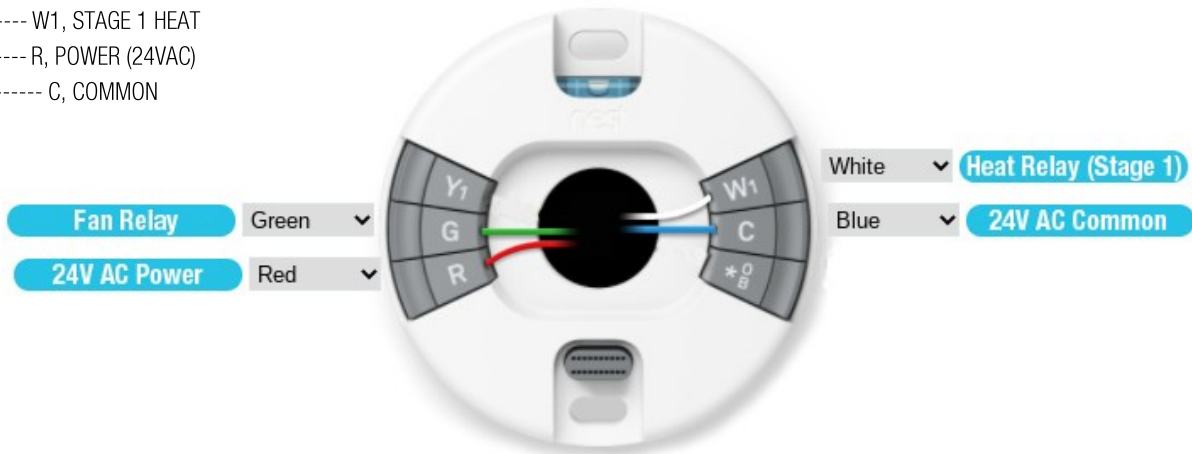

## CONNECTION OF OPTIONAL ECOBEE THERMOSTAT



To connect a Ecobee to PlatinumX, you will need to run multi-conductor thermostat wire between Ecobee Thermostat and the PlatinumX terminal board per the wiring diagram below. Thermostat wire is a class 2 power-limited circuit cable for use in thermostat control applications.

### Conventional 1 Stage Heating **PLATINUMX**

**Ecobee King PlatinumX**

- G ----- G, FAN ONLY
- W1 ----- W1, STAGE 1 HEAT
- RC ----- R, POWER (24VAC)
- C ----- C, COMMON

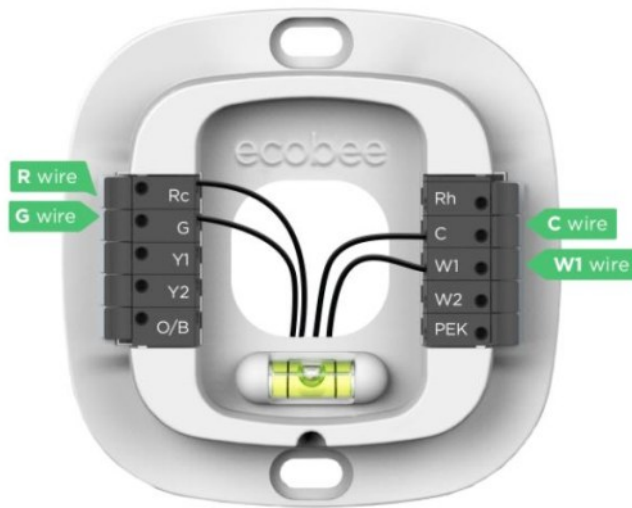

## CONNECTION OF OPTIONAL HONEYWELL THERMOSTAT



Model: RTH9585WF1004

To connect a Honeywell model RTH9585WF1004 to PlatinumX, you will need to run multi-conductor thermostat wire between the Honeywell Thermostat and the PlatinumX terminal board per the wiring diagram below. Thermostat wire is a class 2 power-limited circuit cable for use in thermostat control applications.

### Conventional 1 Stage Heating **PLATINUMX**

**Honeywell King PlatinumX**

- G -----G, FAN ONLY
- W-O/B ----- W1, STAGE 1 HEAT
- R ----- R, POWER (24VAC)
- C ----- C, COMMON

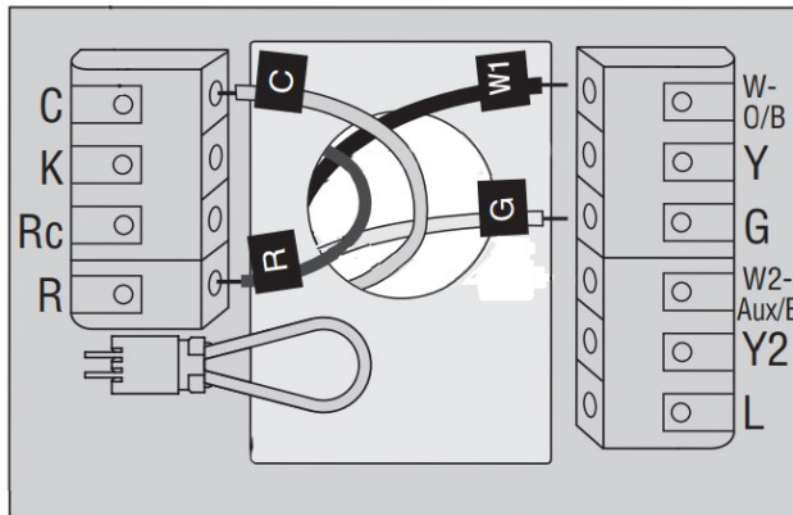

## TROUBLESHOOTING ERROR CODES

Display Code	Display Symbols	Type	Description of Code	Action (if Any)
LS	LS	ERROR	Low Sensor Signal	1. Check and verify Dip Switch settings are correct on the back of the display - reference instruction manual for settings. 2. Move Sensor closer to the heater or away from metal objects that might block the signal.
BA	BA	ERROR	Low Battery Indicator	Indicates batteries should be replaced.
E1	E1	ERROR	Onboard Sensor Error	Indicates an issue with the backup sensor inside the heater and the sensor needs to be replaced. Contact customer support for assistance.
L	L	FEATURE	Display Lock Mode	Press and HOLD Start/Stop button for 5 seconds to turn off Display Lock
BL	BL	OPTIONAL FEATURE	BUILDING MANAGEMENT SYSTEM - SYSTEM LOCKED	Displays when BMS System Contacts are OPEN
OF	OF	OPTIONAL FEATURE	WINDOW/DOOR/PROXIMINTY - SYSTEM OFF	Displays when Window/Door Contacts are OPEN or when Proximity Sensor Contacts are CLOSED
FP	FP	OPTIONAL FEATURE	WINDOW/DOOR/PROXIMINTY - FREEZE POTECTION MODE (40F SETBACK)	Displays when Window/Door Contacts are OPEN or when Proximity Sensor Contacts are CLOSED

## INTERNAL ALARM FOR OVERTEMPERATURE

### Internal Alarm for Overtemperature Scenarios

Each heater comes equipped with a buzzer that will turn on in the event that the manual-reset limit is tripped. Since the unit will be placed in low-traffic and unoccupied spaces, the buzzer will alert anyone nearby that the heater is not active and has an issue that needs to be addressed.

#### Scenarios that could set off the alarm:

- 1.) Inlet blockage restricting air flow
- 2.) Outlet blockage restricting air flow
- 3.) The fan is being restricted from moving
- 4.) The motor failed, stopping the fan from spinning
- 5.) A power outage or loss of power during operation (If the pre-programmed fan-delay does not run, the radiant heat from the elements could trip the temperature limit.)

#### How To Address an Active Alarm

In the event that the buzzer is going off on the unit, remove all power to the unit. Address the surrounding area to make sure there is nothing blocking or covering the unit that may cause excess temperature rises. Remove any objects or dust that may have been restricting the inlet airflow to the back of the unit.

If you do not see any further external issues, verify that the temperatures inside the unit have returned to room temperature. It will take up to 15 minutes for the fixture to cool down before any action can be taken. Once cooled, press the red button on the back side of the unit, located at the top and behind the screen. You should feel the button "compress" back down into it's normal position. If you cannot press the button down, the unit is still too hot.

Now that the manual overtemperature limit is reset, the buzzer will be deenergized when power is returned. Turn on the unit and verify that the motor and fan turn on. In the event that the motor and fan are not functioning, remove the unit from power and contact the maintenance line for repair or replacement.

# ECO PRO CONTROLLER INSTRUCTIONS

KBU PlatinumX BMS models can include an optional ECO PRO Controller, which is a Remote Thermostat, featuring a 7-day programmable heating schedule that puts personalized comfort right at your fingertips. This advanced scheduling function allows users to set different heating profiles for each day of the week, aligning comfort with daily routines while optimizing energy efficiency.

## Meet the ECO PRO CONTROLLER: 7-Day Programmable Thermostat with Remote Temperature Sensing



ECO PRO Controller



7-Day Programmable Heating Schedule



Balanced Heat Throughout the Space



Comfort, Right Where You Want It



Remote Temperature Sensing

# PAIRING ECO PRO CONTROLLER TO HEATER

## KBU PlatinumX with Optional Pro Controller

**IMPORTANT:** The ECO PRO Controller must be paired to the heater prior to use. If heater display shows "L5" the ECO PRO Controller has not been paired successfully. Repeat Pairing Process.

### HEATER DIP SWITCH SETTINGS

**Note:** Dip Switch #1 must be set to OFF for ECO PRO Controller

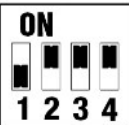

PRO Models Settings)

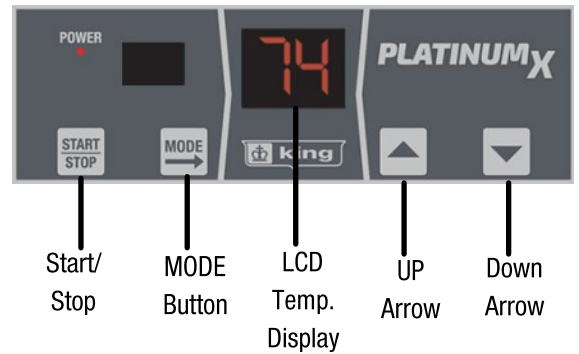

## PAIRING AND USAGE GUIDE

Since it is possible that more than one heater/PRO Controller would be used in a home, you must first pair the PRO Controller to a specific heater. Each PRO Controller has a unique ID number, which will be used in the pairing process. When installing the PRO Controller for the first time, users need to pair the PRO Controller with the heater so that the heater can learn and save the remote sensor's unique ID.

**Step 1:** On the Heater's Display Press and button at the same time for 5 seconds. The LED display will flash "id". Release buttons. The pairing mode will stay active for 20 seconds.

**Step 2:** Put the PRO Controller within 3 feet of the heater and then press and hold the button to enter pairing mode.

**Step 3:** The icon will appear on the PRO Controller, and the heater's display indicator lights will illuminate (LED tubes show 88) for 1 second and then turn off. **This means the Pro Controller and the heater have paired with each other successfully.**

**NOTE:** If the display flashes "id" for 20 seconds and then turns off, it means that the heater failed to pair with the PRO Controller and has exited the Pair mode. Repeat the above steps to pair the remote sensor.

**Step 4:** After pairing the PRO Controller successfully, put the PRO Controller in the room where you want to detect temperature. The heater display will now display the temperature from the remote sensor.

# Installing Batteries / Optional USB-C Adaptor

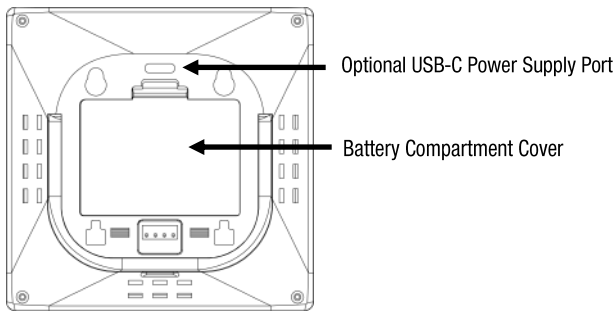

## Installing Batteries / Optional USB-C Adaptor

Open the battery cover and insert 3pcs AAA batteries.

**Important Note:** To conserve battery life the PRO Controller perform a handshake with the heater every 3 minutes. Users may experience up to a 3-minute delay. This delay only occurs when the display is asleep.

**Recommendation:** For instant communication, a standard USB-C cable and power adapter are recommended to provide constant power.

# Low Battery Indicator

## Low Battery Indicator

When batteries are low, "BA" will flash on the heater display and  icon appears on the Pro Controller to indicate batteries should be replaced.

**Note:** If batteries fail, the heater is designed to revert back to the onboard temperature sensor for temperature control until the batteries are replaced in the remote sensor.



# Wall Mounting Instructions

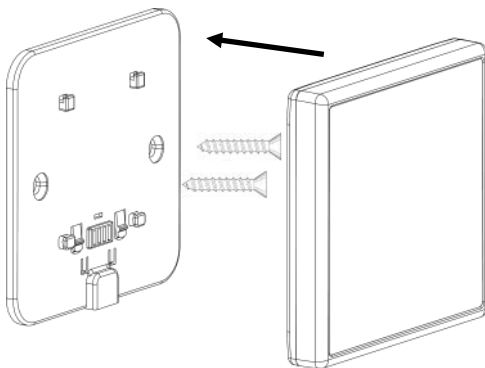

## Wall Mounting The PRO Controller

PRO Controller can be placed on any flat surface with extendable legs or it can be fixed to the wall with the mounting bracket. **Mounting Bracket Install:** Select location for the PRO Controller on the wall, Secure the bracket to with 2 appropriate anchors and screws. Insert PRO Controller into bracket.

# Low Signal Indicator

## Low Signal Indicator

When the PRO Controller is not paired with the heater or if the signal is being blocked. the display flashes "LS". After 10 minutes, the controller will automatically switch to work with the on-board temperature sensor, but the display will continue to flash "LS" until the signal restored.

1. Following Pairing process above to successfully pair the sensor.
2. Move PRO Controller closer to the heater or away from metal objects that might block the signal.

# INITIAL SETUP OF ECO PRO CONTROLLER

## INITIAL SETUP:

Press and hold  and  buttons for 5 seconds to enter SETTINGS steps:

### Setting#1: Set °Celsius or °Fahrenheit

Press  or  to select °C or °F (Default °F).

Press  to save setting and move to next step.

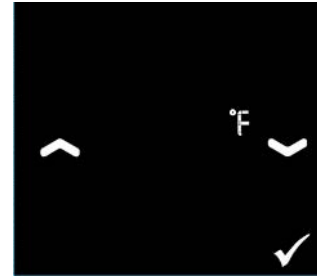

Setting °C or °F

### Setting#2: Set Clock

Press  or  to adjust Day → Hour → Minute.

Press  to save setting and move to next step.

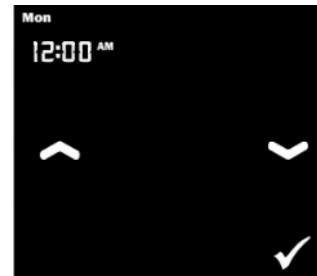

Setting Clock

### Setting#3: Set Temperature Offset:

The Offset value that you set will be added or subtracted from the ambient temperature reading shown on the display. This can be useful to match other temperature reading devices in the space.

Press  or  to adjust the Temperature Offset. (Range -4°F to +4°F)

Press  to save setting and move to next step. (Default 0°F)



Setting Temperature Offset

### Setting#4: Set Brightness:

Press  or  to select the screen's contrast level from 1 (Dimmest) to 7 (Brightest).

Press  to save setting and exit initial setup. (Default 5)



Setting Brightness

# INITIAL SETUP OF ECO PRO CONTROLLER - Cont.

## Setting#5: System OFF or Freeze Protection OFF:

This option sets the preferred setting when the  button is pressed.

Press  or  to select between System OFF or Freeze Protection OFF

Press  to save setting and move to next step.

**System Off** = Disables the relay output and heater will never turn on under any scenario.

When activated **OFF** is shown on display.

**Freeze Protection Off** = Heater will turn on if the ambient room temperature drops below 40F.

When activated **OFF**  is shown on display.

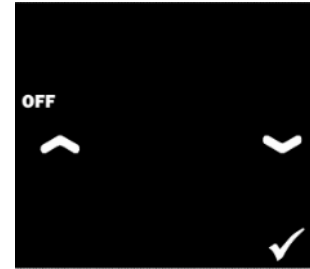

System Off

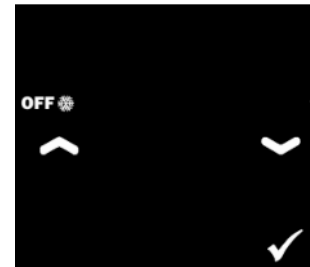

Freeze Protection Off

## Setting#6: WINDOW OPEN SETBACK Temperature (Optional Window/Door Sensor Accessory Required)

Sets the preferred setback temperature if an optional Window/Door sensor is connected to system.

Press  or  to select between 40°F (default), 45°F, 50°F, or 55°F.

Press  to save setting and move to next step.



Window Open Setback

## Setting#7: PIR UNOCCUPIED SETBACK Temperature (Optional PIR Occupancy Sensor Accessory Required)

Sets the preferred setback temperature if an optional PIR Occupancy Sensor is connected to system.

Press  or  to select between 45°F, 55°F, 60°F (default), or 65°F.

Press  to save setting and exit initial setup.





PIR Unoccupied Setback

## Setting#8: MULTIPLE HEATERS INSTALLATION SCENARIO (SAME ROOM OR DIFFERENT ROOMS)

Since ECO PRO Controller can be paired to multiple heaters, the status of each heater will be different under these two scenarios.

This option sets the control logic depending if multiple heaters are installed in a single room or different rooms.

Press  or  to select between 1 = Same Room (Default) or 0 = Different Rooms.



Press  to save setting and exit initial setup.

Note: At any time during the setup process you can Press and Hold the  button for several seconds to exit the initial setup early.

# OPERATION OF ECO PRO CONTROLLER

## PRESET SCENE TEMPERATURES:

ECO PRO Controller has 3 preset scene temperatures that you can quickly select to temporarily override the heating schedule, when your daily routine unexpectedly changes. Their default settings are shown in the following table:

Scene	Icon	Default Temp Settings
Home		70°F
Away		55°F
Sleep		60°F

## HOW TO USE A PRESET SCENE:

Short Press the Preset Scene Temperature Icon  and it will start flashing. With each addition press it will switch between the 3 preset scenes.

Once the Scene you desire is shown, Press  to save Preset Scene.

That preset temperature becomes the current setpoint until the next Heat Schedule period starts, when the heater returns to the programmed heating schedule.



## MODIFYING A PRESET SCENE TEMPERATURE:

Short Press the Preset Scene Temperature Icon  and it will start flashing. With each addition press it will switch between the 3 preset scenes.

Once the Scene you desire to modify is shown, Press  or  to adjust the temperature setpoint for that scene until the new desired setpoint temperature is shown.

Press  to save the new setpoint for the Preset Scene.

Note: This becomes the new setpoint, not only for the Preset Scene but also throughout your heating schedule where that scene is used.

# PROGRAMMING THE HEATING SCHEDULE

## DEFAULT HEATING SCHEDULE:

The ECO Pro Controller uses the PRESET SCENE TEMPERATURES setpoints (as described on the previous page) as the temperature setpoints for the time period in your heating schedule. The default heating schedule is shown in the following table. We recommend using the default schedule since it was designed to help reduce your heating expenses.





The schedule consists of 4 periods per day, which represents a typical work day.

The HOME  preset temperature is automatically used in Periods 1 and 3.

The AWAY  preset temperature is automatically used in Period 2.

The SLEEP  preset temperature is automatically used in Period 4.

You can have a different schedule for every day; i.e., each period can start at a different time every day.

Period	Icon	Scene	Mon	Tue	Wed	Thr	Fri	Sat	Sun
①		Home	6:00 AM	6:00 AM	6:00 AM	6:00 AM	6:00 AM	6:00 AM	6:00 AM
②		Leave	8:00 AM	8:00 AM	8:00 AM	8:00 AM	8:00 AM	8:00 AM	8:00 AM
③		Home	6:00 PM	6:00 PM	6:00 PM	6:00 PM	6:00 PM	6:00 PM	6:00 PM
④		Sleep	10:00 PM	10:00 PM	10:00 PM	10:00 PM	10:00 PM	10:00 PM	10:00 PM

The PRO Controller has been factory programmed with the above schedule.

## HOW TO MODIFY THE HEATING SCHEDULE:

**Step 1:** Press  to start the process.

Mon begins to flash. Press  or  to select the Day of the Week you would like to modify.



**Step 2:** Press  again to move to the next step and select the Time Period you would like to modify.

Period 1 icon  begins to flash. If changing Period 1, Press  again to move to next step. Or Press  or  to change to the Time Period you would like to modify such as Period 2  or Period 3  or Period 4 .



# PROGRAMMING THE HEATING SCHEDULE

## HOW TO MODIFY THE HEATING SCHEDULE - Continued:

**Step 3:** Press  again, Hour begins to flash. Press  or  to modify the Hour period starts.

**Step 4:** Press  again, Minutes begin to flash. Press  or  to modify Minutes period starts.

**Step 5:** Press  again to select the next period of the selected day to modify that period program according to the steps above.



After modifying the heat schedule as needed, Press  to save setting or wait for 15 seconds and the setting will be saved automatically.

## COPY & PASTE A DAY'S SCHEDULE - Save Time Programming!

If you would like to copy the schedule for a specific day and add it to other days of the week, follow these steps and save time!

**Step #1** After changing the schedule for a specific day (example Mon), Press  to save the day's schedule.

**Step #2** Press the  icon to copy the selected day's schedule (example Mon). The remaining Days of the Week will appear on the screen.



**Step #3** Press each day of the week that you want to paste Monday's schedule to. (For example: Tues, Wed, Thr, Fri).

As you press each day, a line will appear under the days you have selected.

**Step #4** Press  to confirm the pasted schedule.

## HEATING SCHEDULE OVERRIDE / ADJUSTING THE TEMPERATURE - (Temporary)

To adjust the desired temperature up or down, touch  and  on the thermostat home screen.

**Note: Adjusting the temperature will temporarily override the current set point until the next schedule period unless you want to use one of the schedule overrides below.**

# GENERAL OPERATION

## ECO PRO CONTROLLER OPERATING MODES

### SYSTEM MODES:

PRO Controller has 3 system modes (**Schedule**, **Override**, **Permanent Hold**) that indicate if the state of the system. The current mode is displayed to the right of the **Set To** temperature on the home screen. The **set duration** of the current mode is displayed to the right of that, showing the time the system mode is active until. This makes it easy to identify when the next system change will occur.

- Schedule:** System is running based on the programmed heating schedule.
- Override:** System, is running based on a manually set override for a limited amount of time.
- Permanent Hold:** System is running on a manually set override that will be permanently held until manually turned off.









### OPERATION MODES:

PRO Controller has 4 operation modes (**Heat**, **Timer**, **Hold**, **Fan Only**). The current mode is displayed on the left, under the **Date and Time** on the home screen. The **set duration** of the current mode is displayed at the bottom right of the **Set To** temperature, showing the time it is active until.



To cycle through the available operation modes, touch **Mode**  on the thermostat home screen and select the appropriate mode and settings.

- Heat:** This is the default operation mode based on the heating schedule you have programmed.
- Timer:** This is a **temporary** system override based on the current system settings, that will expire after on a length of time you set.
- Hold:** This is a **permanent** system override that holds the current system settings permanently, until manually canceled.
- Fan Only:** This is a operating mode to run the fan only, typically used in the summer for cooling.

### CHANGING THE OPERATION MODES:

**Timer Mode:** Press  once to enter into **Timer Mode**.  
 The timer Hour begins to flash. Press  or  to adjust the Hour for when the timer expires.  
 Press  and **Minutes** begin to flash. Press  or  to adjust.  
 Press  to save. Pro Controller will run based on current settings for that set period of time.

To cancel, press  three times get to Heat mode. Press  to save the mode.

**Hold Mode:** Press  two times to enter into **Hold Mode**.  
 Press  to save the mode.  
 Pro Controller will permanently hold the current temperature until manually canceled.

To cancel, press  two times get to Heat mode. Press  to save the mode.



Timer Mode



Hold Mode

# GENERAL OPERATION

## CHANGING THE OPERATION MODES - Continued:

**Fan Only Mode:** Press  three times to enter into Fan Only Mode.  
Press  to save the mode.

When fan mode is selected there is no heat output. Fan turns on when room temperature is higher than the set temperature. When room temperature drops to the set temperature, fan turns off.

**Note:** The system functions as a cooling thermostat.



Fan Only Mode

To cancel, press  one time get to Heat mode. Press  to save the mode.

**Heat Mode:** Press  four times to return to Heat Mode. System functions based on Programmed Heat Schedule again.  
Press  to save the mode.

## SYSTEM OFF/STANDBY FUNCTION:

Press  button to enter or exit Standby Mode.

System will enter "System Off" or "Freeze Protection Off", depending on what default was set during INITIAL SETUP



System Off



Freeze Protection Off

(Heat Stays OFF Regardless of Room Temp)

## MULTIPLE HEATERS PAIRED TO CONTROLLER - SYSTEM STATUS CHECK:

When multiple heaters are paired to a single ECO PRO Controller, if the heaters are installed in different rooms the status of each heater will be different based on the ambient temperature in each room. Follow the below steps to check the status of each heater:

Long press  for 5s to enter the check mode. The middle number represents different heaters, press  or  to check the status of each heater and the mode of it. Press  to exit the check mode.

# GENERAL OPERATION

## MAX TEMPERATURE LIMIT SETTING:

This setting allows the user to set a limit on the highest temperature setting allowed on the thermostat. It can be used in high traffic areas and can help prevent energy waste.

Press  button to enter OFF mode

Press and hold  and  button simultaneously for 5 seconds to enter **Max Temperature** setting mode

Press  or  to adjust the max temperature (40~95 °F)

Press  to confirm the setting or wait for 15 seconds and the setting will be saved automatically.

## DISPLAY LOCK MODE:

Display Lock is designed for high traffic areas and deactivates the heater display buttons to prevent unwanted temperature adjustments. However settings can still be adjusted through the remote control.

Press and hold  and  button simultaneously for 5 seconds to enter **Display Lock Mode**. All buttons on the Heater Display and ECO Pro Controller will be disabled until unlocked.

To Unlock: Press and hold  and  button for 5 seconds to exit **Display Lock Mode**.

**Note:** While in Display Lock Mode, the heater operates at the last known settings.



Display Lock

## LOW BATTERY INDICATOR

When running on battery power, when the batteries are low on power the display shows . Replace batteries or plug into wall power.



Low Battery Indicator

## FACTORY RESET UNIT

Press and hold  and  button simultaneously for 10 seconds.

All lights on the display will flash to confirm reset was completed and then the unit returns to its factory default settings & program.

## DISPLAY WAKEUP (Wall Adaptor Connected)

The controller has a proximity sensor, so as you approach the controller the display will turn on automatically (detection range is 5 feet). When there is no activity for 30 seconds, the display will turn off automatically.

If the display does not turn on when you approach the controller, you can also press the  icon on the display to wake it up.

## DISPLAY WAKEUP (Battery Powered)

When powered with batteries only, the display will automatically turn off after 15 seconds to save battery life.

Press the  icon the display to wake it up.

**Important Note:** To conserve battery life the PRO Controller perform a handshake with the heater every 3 minutes. Users may experience up to a 3-minute delay.

**Recommendation:** For instant communication, a standard USB-C cable and power adapter are recommended to provide constant power.

# CREATE A HEATING ZONE - Connect Multiple Heaters

## Control Temperatures and Save Energy with Zoned Heating Systems

A zoned heating system allows homeowners to control the temperature of each room or zone individually, thereby maximizing comfort and minimizing energy costs. A zoned system can be adjusted for numerous factors, including room usage, personal preferences, and environmental conditions. Zoned systems help homeowners use their heating systems more effectively by distributing heat where and when it is needed.

A single ECO Pro Controller can be paired to multiple heaters, creating a Heating Zone that is controlled by a single heating schedule. All heaters in this zone will be synchronized to the heating schedule of the ECO Pro Controller.

## Creating a Heating Zone

### Step 1: Pair Multiple Heaters To A Single ECO PRO Controller

Follow the **Pairing and Usage setup instructions on page 7** of this manual to pair each heater in the required heating zone to a single ECO PRO Controller. After pairing the first heater, repeat steps to pair each additional heater.

### Step 2: Program The Desired Heating Schedule

Follow the **Program The Heating Schedule instructions on page 14** to create a heating schedule for the ECO PRO Controller.

### Step 3: Operation

All heaters within this heating zone are now synchronized and will operate off the programmed heating schedule. Any changes made to the ECO PRO Controller will effect all heaters in this zone. The ambient room temperature will be detected at the location of the ECO PRO Controller, so proper placement of the ECO PRO Controller is important. Locate the ECO PRO Controller in the coldest spot in the heating zone to eliminate any cold areas within the zone.

DIAGRAM OF AN EXAMPLE HEATING ZONE

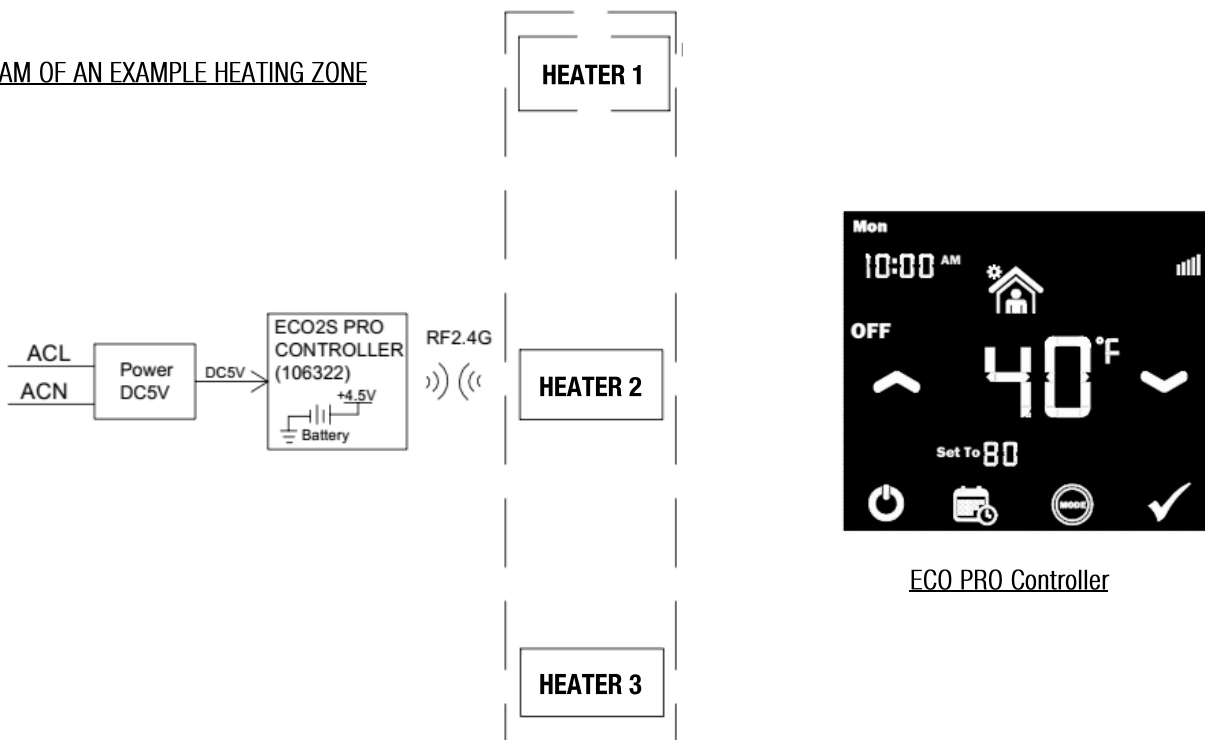

ECO PRO Controller