

Compact Unit Heater KBP PlatinumX Series



With U.S. & Global Materials



Model Code:

KBP 48 06 -3MP -MB -PLTMX
A B C D E F

A: Series
B: 20 - 208V, 24 - 240/208V
27 - 277V, 48 - 480V
C: Watts (950 to 5700)
D: -1 = Single Phase
-3 = Three Phase
-3MP = 1-3 Phase
E: -Mounting Bracket
F: -PLTMX = 1-Stage Electronic Control
+ 24V Remote Stat Provision

PLATINUMX

- Energy-Saving PlatinumX electronic controller
- Hand held remote & wall holder
- Built-In provision for optional 24V remote thermostat
- Compatible with NEST / any 24V WIFI stat
- Compatible with BMS systems
- Timer & Summer Fan Only Modes
- Auto Memory Feature: returns units to last settings after power outage
- 385 CFM output
- Adjustable louvers to direct air
- Built-In fan delay to dissipate heat
- Dual Pic-A-Watt® elements
- Patented Smart Limit® Protection
- Universal Wall/Ceiling bracket included
- 5-Year limited warranty

The KBP PlatinumX Compact Unit Heater

King's KBP PlatinumX series unit heaters are the most full-featured compact unit heaters on the market, with in-built electronic thermostat for accuracy and remote control for simple operation. Comes standard with a provision for adding an optional 24V thermostat, allowing for remote temperature control or integration with a building management system (BMS). Combined with summer fan-only and thermostat timer modes, the KBP PlatinumX adapts to your needs year-round.

Designed for rugged performance, the flow-through design efficiently moves air by pulling air from the back of the heater and discharges it out the front, easily heating a large space. The integral fan delay continues to dissipate heat from the elements during the cool down period, maximizing the heat exchange in the room. King's exclusive dual Pic-A-Watt steel fin elements allow customers to select from a range of wattage options, tailoring the heater to an area's specific heating requirements.

PlatinumX Electronic Controller Features

- Electronic control for accuracy
- Thermostat timer mode (1-9 Hours)
- Summer Fan only mode
- Large LED display
- Built-In fan delay
- Built-In provision for optional 24V remote thermostat
- Remote control and wall/ceiling bracket included
- Compatible with NEST / any 24V WIFI Stat
- Compatible with Building Management Systems (BMS)

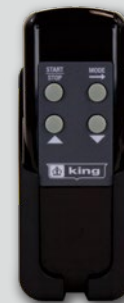

IR Remote

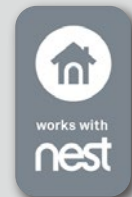

or Any 24V
WIFI Stat

Ordering Information - Electronic 1-Stage Thermostat

MODEL	UPC	WATTS	MAX BTUH (000)	PHASE	VOLTS	AMPS	CFM	TEMP. RISE	AIR THROW	MAX MOUNT HEIGHT (lbs.)	WT.
KBP2706-1-MB-PLTMX	70541	5700-4750-3800-2850-1900-950	19,454	1	277	14.5 - 3.6	385	33°F-8°F	12 ft.	8 ft.	26
KBP2005-3MP-MB-PLTMX	70542	5000-2900-2200	17,060	1-3**	208	15.8 - 7.9	385	41°F-23°F	12 ft.	8 ft.	26
KBP2406-3MP-MB-PLTMX	70543	5700-2850	19,454	1-3**	240/208*	13.7 - 6.9	385	47°F-8°F	12 ft.	8 ft.	26
KBP4806-3MP-MB-PLTMX	70544	5700-2850	19,454	1-3**	480	7.2	385	49°F	12 ft.	8 ft.	26

*Approved for 208V operation. Heater will draw 13% less Amps and 25% less wattage **3MP Prewired for 3-Phase, Field Convertible to 1-Phase

Optional Field-Installed Disconnect Kit

MODEL	UPC	DESCRIPTION
KBP-HFD-KIT	70470	KBP Heat/Disconnect Switch, 120-277V, Field Installed Kit
KBP-480HFD-KIT	70551	KBP Heat/Disconnect Switch, 480V, Field Installed Kit

Compact Unit Heater KB PlatinumX Series

Dimensional Data

Minimum clearance from combustibles: 18" from front, 2" from top, 6" from sides and 5" from rear. Minimum clearance 6' from floor.
(Optional Disconnect Switch Shown)

PLATINUMX

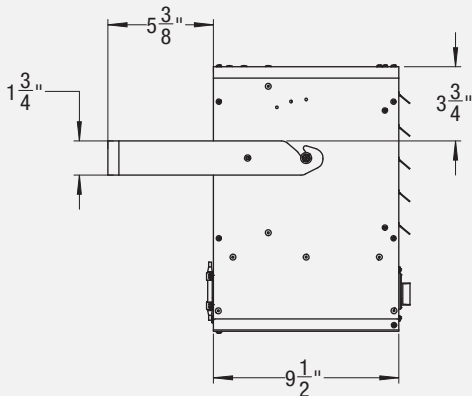
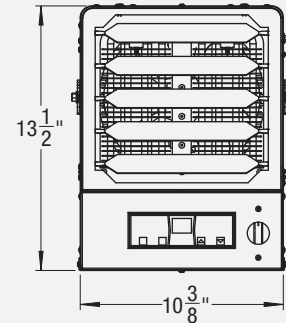
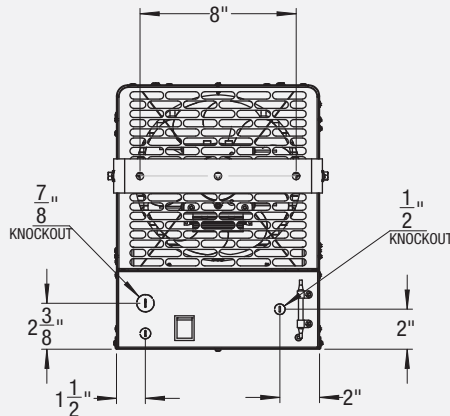
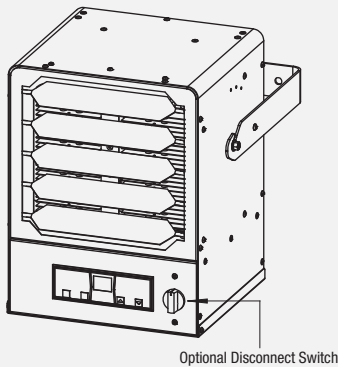

TEMPERATURE RISE PER WATTAGE CHART

WATTS	BTUH	CFM	TEMP. RISE	WATTS	BTUH	CFM	TEMP. RISE
950	3,242	385	8	3800	12,969	385	31
1000	3,413	385	8	4000	13,652	385	33
1900	6,485	385	16	4160	14,198	385	34
2000	6,826	385	16	4750	16,212	385	39
2850	9,727	385	23	5700	19,454	385	47
3000	10,239	385	25	6000	20,478	385	49

Engineering Specifications

Contractor shall supply and install KB PlatinumX Series unit heaters manufactured by King Electrical Mfg. Company. Heaters shall be of the wattage and voltage as indicated on the plans.

Construction: All exterior and interior metal enclosure parts are made from 20 gauge electrogalvanized Steel with a rust inhibiting baked enamel finish. Smooth rounded corners and protective edge trim give an attractive modern appearance.

PlatinumX Electronic Thermostat Control: Thermostat Temperature Range: 40° to 95°. Up, down temperature mode. Start/Stop. Standard on all heaters. Heaters 25kW and above are ECO2S+ 2-stage heaters.

Provision For 24V Remote Thermostat: Includes terminals to connect an optional 24V 2-Stage Thermostat. Compatible with NEST / any 24V WIFI Stat or for integration with a building management system (BMS).

Auto Memory Feature: Returns Unit To Last Settings After Power Outage.

Adjustable Outlet Louver: Louvers direct air up or down as needed for the heating application.

Rear Intake Screen: Heavy gauge steel screen protects against foreign objects making accidental contact with the rotating fan blade.

Pic-A-Watt Heating Elements: Exclusive King multi-tap element allows field adjustment to several wattages at time of installation. Steel sheath elements of various resistance are copper brazed to steel plate fins producing a multi-wattage heating element.

Unit Bearing Motor: Permanently lubricated, long life, unit bearing 4-Pole motor with 20 cc of oil. Enclosed rotor provides long-lasting, trouble-free operation. Thermally protected. 1500 RPM.

Aluminum Fan Blade: 5 blade fan mounted directly to the motor shaft for maximum efficiency.

CFM: 385

Universal Mounting Bracket: Combination ceiling/wall bracket is included with every heater.

Patented Smart Limit Protection (U.S. Patent #6,748,163 B2): Equipped with King's patented thermal overload Smart Limit Protection®, which disconnects elements and motor in the event normal operating temperatures are exceeded. If thermal overload trips due to abnormal operating temperatures, thermal overload shall remain open until manually reset by turning the heater off for 15 minutes. Automatically reset of thermal overloads, which allow the element to continue to cycle under abnormal conditions, will not be accepted.

Fan Delay: The fan continues to operate after the thermostat shuts off in order to remove the residual heat left in the elements. Power must not be interrupted.

Standard Color: Onyx Gray

Easy Installation: A quick access panel located on the bottom of the heater allows for quick wiring and easy maintenance for the life of the heater. Includes universal wall/ceiling bracket for simple installation.

Approvals: cULus (E41422)