

Compact Unit Heater KBP ECO2S Series



Model Code:

KBP 24 06 -1 -MB -ECO2S
A B C D E F

- A: Series
- B: 12 - 120V, 20 - 208V, 24 - 240/208V
- C: Watts (950 to 5700)
- D: -1 = Single Phase
- E: -Mounting Bracket
- F: -ECO2S = 2 Stage Electronic Control



- Energy-Saving ECO2S electronic controller
- 2-Stage heating
- Hand held remote & wall holder
- Timer & Summer Fan Only Modes
- Auto Memory Feature: returns units to last settings after power outage
- 385 CFM output
- Adjustable louvers to direct air
- Built-In fan delay to dissipate heat
- Dual Pic-A-Watt® elements
- Patented Smart Limit® Protection
- Universal Wall/Ceiling Bracket Included
- 5-Year Limited Warranty

KBP ECO2S 2-Stage Compact Unit Heater with IR Remote Control

The KBP ECO2S series compact unit heater delivers exceptional performance, energy efficiency, and user control, featuring King's innovative built-in ECO2S electronic thermostat with remote control. The heaters provide energy-efficient 2-stage heating, an Eco mode that automatically uses the lowest wattage needed, integrated fan-only and timer modes, and a convenient remote for simple operation.

Built for rugged performance, the flow-through design efficiently draws air in from the back and discharges it out the front, quickly heating large spaces. An integral fan delay continues to circulate heat during cool down, maximizing warmth. King's exclusive dual Pic-A-Watt steel fin elements provide a range of wattage options, letting you tailor the heater to the specific requirements of any area.

ECO2S Electronic Controller Features:

- Electronic control for accuracy
- Energy-saving automatic 2-stage heating
- Large LED display
- Remote control and wall bracket included
- Thermostat timer mode (1-9 Hours)
- Fan only mode
- Built-In fan delay



Ordering Information - Electronic 2-Stage Thermostat

MODEL	UPC	WATTS	MAX BTUH (000)	PHASE	VOLTS	AMPS	CFM	TEMP. RISE	AIR THROW	MAX MOUNT HEIGHT	WT. (lbs.)
KBP1230-1-MB-ECO2S	70454	(2850-1900-950)	9,727	1	120	23.8 - 15.8	385	23°F-8°F	12 ft.	8 ft.	26
KBP2005-1-MB-ECO2S	70455	(5000-4000-3600-2290-1450-950)	17,060	1	208	27.4 - 22.8	385	41°F-8°F	12 ft.	8 ft.	26
KBP2406-1-MB-ECO2S	70456	(5700-4750-3800-2850-1900-950)	19,454	1	240/208*	23.8 - 19.8	385	47°F-8°F	12 ft.	8 ft.	26

*Approved for 208V operation. Heater will draw 13% less Amps and 25% less wattage

Optional Field-Installed Disconnect Kit

MODEL	UPC	DESCRIPTION
KBP-HFD-KIT	70470	KBP Heat/Disconnect Switch, 120-277V, Field Installed Kit
KBP-S2-SMB	70570	Optional Swivel Mounting Bracket
KBP-S2-MB	70571	Replacement Universal Mounting Bracket

TEMPERATURE RISE PER WATTAGE CHART

WATTS	BTUH	CFM	TEMP. RISE	WATTS	BTUH	CFM	TEMP. RISE
950	3,242	385	8	3800	12,969	385	31
1000	3,413	385	8	4000	13,652	385	33
1900	6,485	385	16	4160	14,198	385	34
2000	6,826	385	16	4750	16,212	385	39
2850	9,727	385	23	5700	19,454	385	47
3000	10,239	385	25	6000	20,478	385	49

Dimensional Data

Minimum clearance from combustibles: 18" from front, 2" from top, 6" from sides and 5" from rear. Minimum clearance 6' from floor.
(Optional Disconnect Switch Shown)

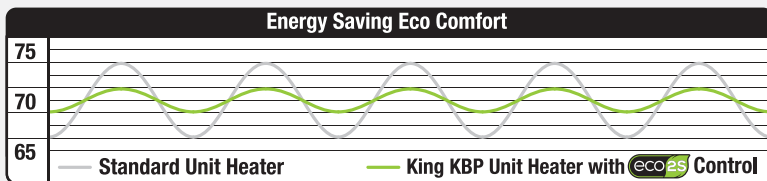
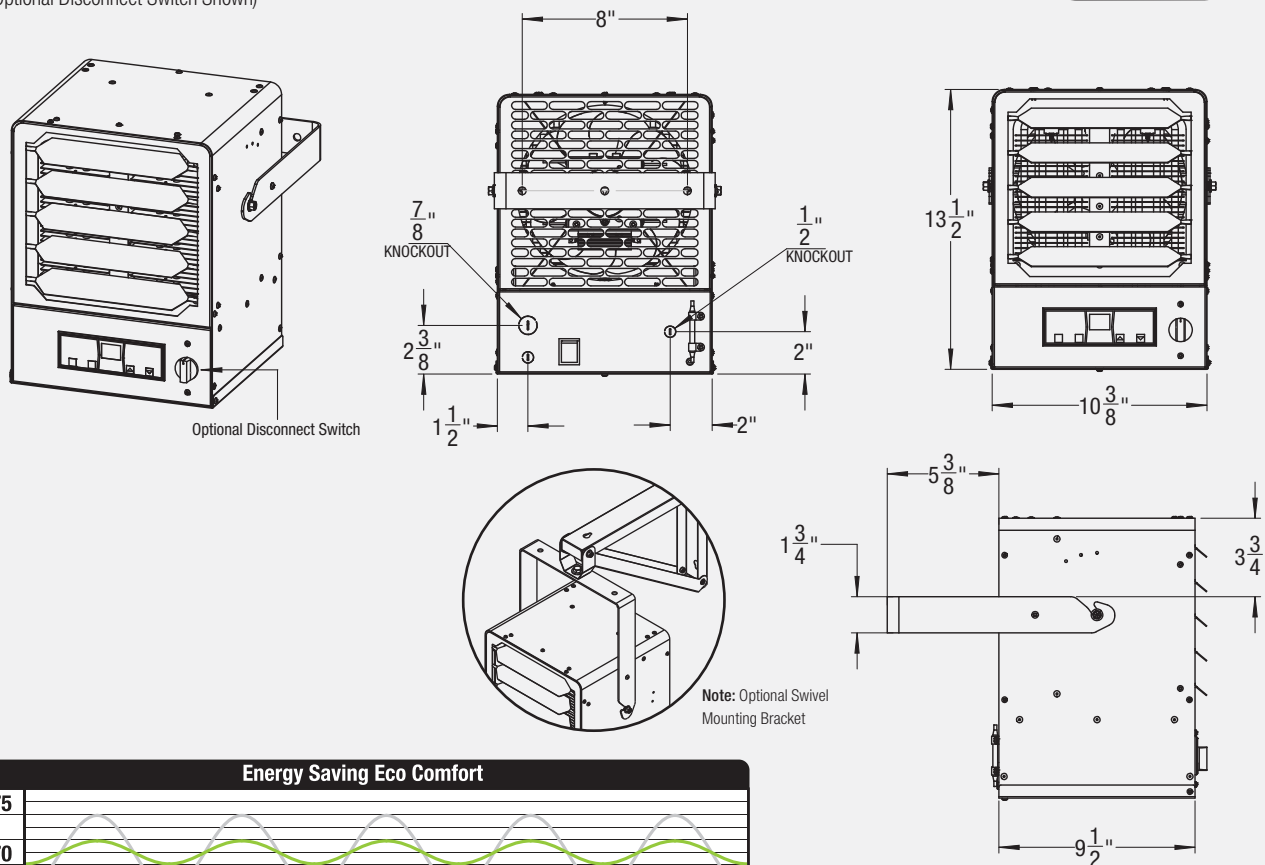

*Reduces temperature swings

Engineering Specifications

Contractor shall supply and install KBP ECO2S Series unit heaters manufactured by King Electrical Mfg. Company. Heaters shall be of the wattage and voltage as indicated on the plans.

Construction: All exterior and interior metal enclosure parts are made from 20 gauge electrogalvanized Steel with a rust inhibiting baked enamel finish. Smooth rounded corners and protective edge trim give an attractive modern appearance.

ECO2S Electronic Thermostat Control: Thermostat Temperature Range: 40° to 95°. Up, Down temperature mode. Automatic 2-Stage heating (High & ECO Modes). Start/Stop. Fan Only and Timer (1-9hours) Modes. Standard on all heaters.

Auto Memory Feature: Returns Unit To Last Settings After Power Outage.

Adjustable Outlet Louver: Louvers direct air up or down as needed for the heating application.

Rear Intake Screen: Heavy gauge steel screen protects against foreign objects making accidental contact with the rotating fan blade.

Pic-A-Watt Heating Elements: Exclusive King multi-tap element allows field adjustment to several wattages at time of installation. Steel sheath elements of various resistance are copper brazed to steel plate fins producing a multi-wattage heating element.

Unit Bearing Motor: Permanently lubricated, long life, unit bearing 4-Pole motor with 20 cc of oil. Enclosed rotor provides long-lasting, trouble-free operation. Thermally protected. 1500 RPM.

Aluminum Fan Blade: 5 blade fan mounted directly to the motor shaft for maximum efficiency.

CFM: 385

Universal Mounting Bracket: Combination ceiling/wall bracket is included with every heater.

Patented Smart Limit Protection (U.S. Patent #6,748,163 B2): Equipped with King's patented thermal overload Smart Limit Protection®, which disconnects elements and motor in the event normal operating temperatures are exceeded. If thermal overload trips due to abnormal operating temperatures, thermal overload shall remain open until manually reset by turning the heater off for 15 minutes. Automatically reset of thermal overloads, which allow the element to continue to cycle under abnormal conditions, will not be accepted.

Fan Delay: The fan continues to operate after the thermostat shuts off in order to remove the residual heat left in the elements. Power must not be interrupted.

Standard Color: Onyx Gray

Easy Installation: A quick access panel located on the bottom of the heater allows for quick wiring and easy maintenance for the life of the heater. Includes universal wall/ceiling bracket for simple installation.

Approvals: cULus (E41422)