

Lead Free Terminator G



Y-Pattern Multi-turn • Globe Valve • Threaded and Solder Connections • Memory Stop • 300 WOG



TGG

Features

- "Y" pattern globe style design
- Lead free dezincification brass
- Positive shut-off
- Offsetting pressure/temperature ports
- Multi-turn, 360° handwheel with vernier scale and digital readouts
- Built-in memory stop
- Precise flow measurement and flow balancing
- Contains less than 0.25% lead content by weight on wetted surfaces
- Lead Free compliant to NSF 372



Temperature and Pressure Rating

- 300 PSI
- -4°F to 250°F

Dimensions

Part Number	Size	A	B	C	Minimum Flow	Nominal Flow	Maximum Flow
TGG-AFF	1/2"	3.39	3.74	1.57	0.14	0.50-3.08	12.10
TGG-BFF	3/4"	3.54	3.74	1.65	0.26	3.80-5.50	17.40
TGG-CFF	1"	4.02	3.78	1.73	0.37	5.50-9.50	30.00
TGG-DFE	1-1/4"	4.72	3.78	1.85	0.60	9.50-14	44.60
TGG-EFF	1-1/2"	5.20	4.25	1.93	0.91	14-20	66.40
TGG-FFF	2"	6.46	4.37	2.09	1.52	20-33	107.20
TGG-ACC	1/2"	3.39	3.74	1.57	0.14	0.50-3.08	12.10
TGG-BCC	3/4"	3.54	3.74	1.65	0.26	3.80-5.50	17.40
TGG-CCC	1"	4.02	3.78	1.73	0.37	5.50-9.50	30.00
TGG-DCC	1-1/4"	4.72	3.78	1.85	0.60	9.50-14	44.60
TGG-ECC	1-1/2"	5.20	4.25	1.93	0.91	14-20	66.40
TGG-FCC	2"	6.46	4.37	2.09	1.52	20-33	107.20

Material Specifications

Part	Material
Body	Lead Free DZR Brass C69300
Bonnet	Lead Free DZR Brass C27453
Gasket	EPDM
Seat Seal	EPDM
Hand Wheel	Plastic

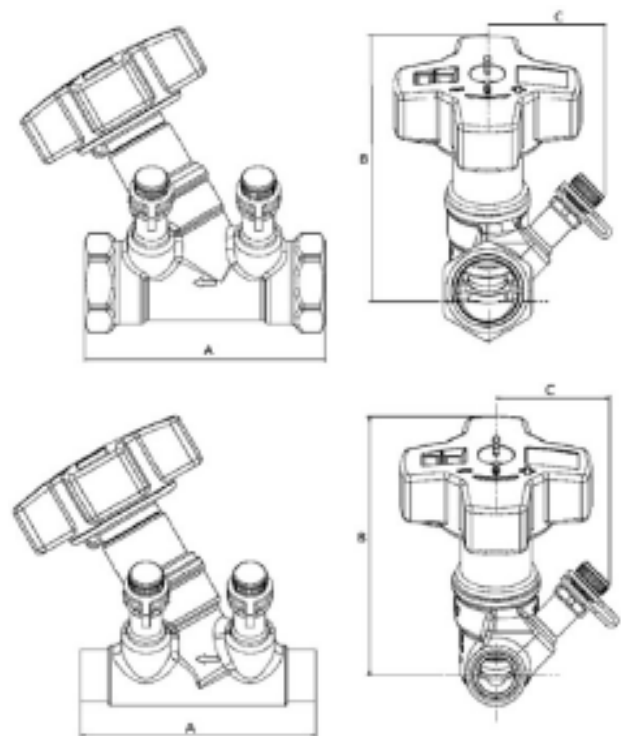

Cv Values

Handwheel Setting	1/2"	3/4"	1"	1-1/4"	1-1/2"	2"
1	0.21	0.39	0.56	0.92	1.39	2.32
1.5	0.29	0.56	0.75	1.28	1.97	3.25
2	0.37	0.70	0.89	1.53	2.38	4.18
2.5	0.44	0.82	1.04	1.80	2.78	5.10
3	0.52	0.96	1.19	2.09	3.25	6.03
4	0.72	1.31	1.74	3.13	4.76	8.82
5	1.00	1.80	2.67	4.76	7.19	13.80
6	1.36	2.44	4.18	6.84	10.30	19.40
7	1.88	3.36	5.80	9.05	13.90	24.60
8	2.96	4.47	7.54	11.30	17.10	29.00
9	3.65	5.22	9.16	13.30	19.80	33.20
10	4.12	5.92	10.2	15.2	22.6	36.5

Smart Part Ordering Guide

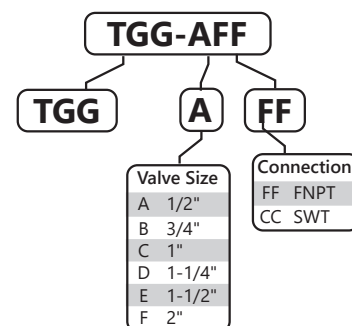

WARNING: This product can expose you to chemicals including lead, which is known to the State of California to cause cancer, and lead, which is known to the State of California to cause birth defects or other reproductive harm. For more information go to www.P65Warnings.ca.gov.

Y-Pattern Multi-turn • Globe Valve • Threaded and Solder Connections • Memory Stop • 300 WOG

TGG

0.50" - 2.00"

This diagram details the relationship between flow, pressure drop and valve preset points. Use the diagram to select the correct valve size and corresponding handwheel setting to fulfill the application requirements.

Determine the required flow in the circuit (A) and the pressure drop (B). Draw a line between these two values. Read off the corresponding Cv value on the Cv scale.

Determine the valve setting, in handwheel turns, by drawing a horizontal line (D) from the intersection point on the Cv scale to the corresponding valve setting position.

For the highest level of accuracy, it is recommended to choose a valve that has at least 3 open turns.

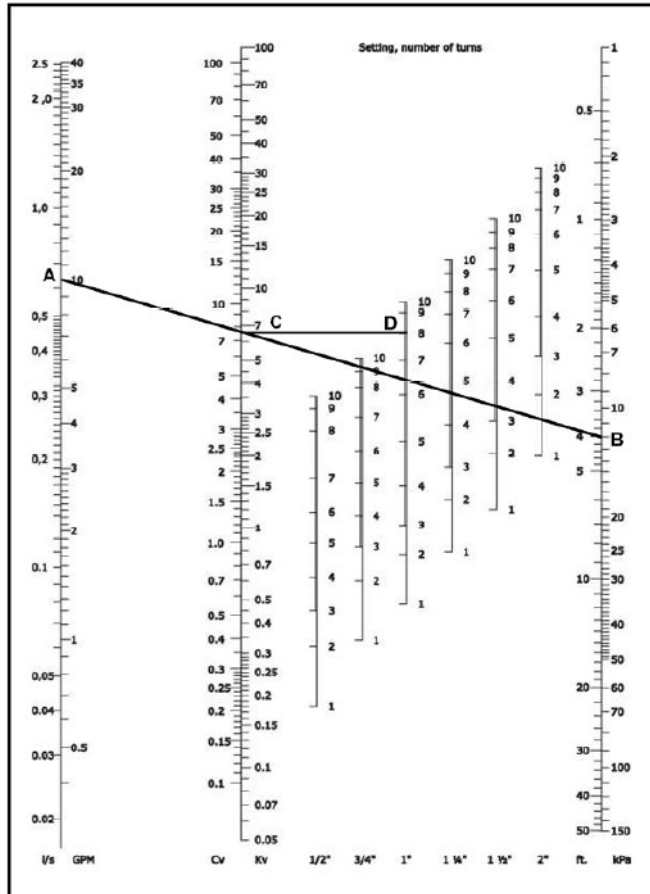

Example: A 1" valve is required to be open 8 turns for a Cv value of 7.5 at a flow rate of 10 gpm and a pressure drop of 4ft.

Installation Recommendations

Install the valve in the correct flow direction according to the arrow on the valve body and the distance parameters detailed in Figure 1. (Note: D = pipe diameter).

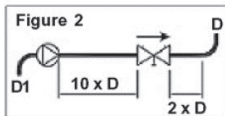
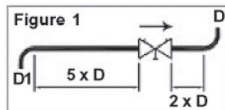

When used with a pump, it is recommended to use a straight length of pipe totaling 10 x D (instead of 5 x D) upstream or downstream to avoid turbulence that will affect the measuring accuracy. See Figure 2.

Turbulence can influence the measurements by up to 20% if this recommendation is not followed.

Cv values for TGG

Flow coefficient values (Cv's) at various handwheel settings.	1/2"	3/4"	1"	1-1/4"	1-1/2"	2"
Handwheel Setting	DN 15	DN 20	DN 25	DN 32	DN 40	DN 50
1	0.21	0.39	0.56	0.92	1.39	2.32
1.5	0.29	0.56	0.75	1.28	1.97	3.25
2	0.37	0.70	0.89	1.53	2.38	4.18
2.5	0.44	0.82	1.04	1.80	2.78	5.10
3	0.52	0.96	1.19	2.09	3.25	6.03
3.2	0.56	1.02	1.28	2.26	3.48	6.50
3.4	0.59	1.09	1.39	2.44	3.71	6.96
3.6	0.63	1.16	1.51	2.67	4.06	7.54
3.8	0.67	1.23	1.62	2.90	4.41	8.12
4	0.72	1.31	1.74	3.13	4.76	8.82
4.2	0.77	1.39	1.91	3.42	5.10	9.74
4.4	0.81	1.48	2.09	3.71	5.57	10.70
4.6	0.87	1.58	2.26	4.06	6.03	11.70
4.8	0.93	1.68	2.44	4.41	6.61	12.80
5	1.00	1.80	2.67	4.76	7.19	13.80
5.2	1.07	1.91	2.90	5.16	7.77	15.00
5.4	1.14	2.03	3.19	5.57	8.35	16.00
5.6	1.21	2.16	3.48	5.97	8.93	17.20
5.8	1.28	2.30	3.83	6.38	9.63	18.30
6	1.36	2.44	4.18	6.84	10.30	19.40
6.2	1.44	2.60	4.47	7.25	11.00	20.40
6.4	1.52	2.76	4.76	7.66	11.80	21.50
6.6	1.62	2.96	5.10	8.12	12.50	22.50
6.8	1.74	3.16	5.54	8.58	13.20	23.50
7	1.88	3.36	5.80	9.05	13.90	24.60
7.2	2.06	3.60	6.15	9.51	14.60	25.50
7.4	2.26	3.83	6.50	9.98	15.30	26.40
7.6	2.49	4.06	6.84	10.40	15.90	27.40
7.8	2.73	4.27	7.19	10.80	16.50	28.20
8	2.96	4.47	7.54	11.30	17.10	29.00
8.2	3.13	4.63	7.89	11.70	17.60	29.90
8.4	3.29	4.78	8.24	12.20	18.20	30.70
8.6	3.42	4.93	8.58	12.60	18.80	31.60
8.8	3.54	5.08	8.87	13.00	19.40	32.40
9	3.65	5.22	9.16	13.30	19.80	33.20
9.2	3.77	5.36	9.40	13.70	20.30	33.90
9.4	3.87	5.50	9.63	14.20	20.90	34.60
9.6	3.98	5.64	9.86	14.50	21.50	35.30
9.8	4.06	5.78	10.00	14.80	22.00	36.00
10	4.12*	5.92*	10.2*	15.2*	22.6*	36.5*

* Valve is fully open

Flow Measurement & Accuracy

Determined using the pressure drop diagram that is included in the operating instructions with each Jomar Balancing Valve.

The accuracy is highest when the valve is fully open. Therefore, it is recommended to choose a valve that can be opened at least three turns at the calculated pre-setting value. Figure 3 represents the flow measurement deviation in relation to handwheel turns.

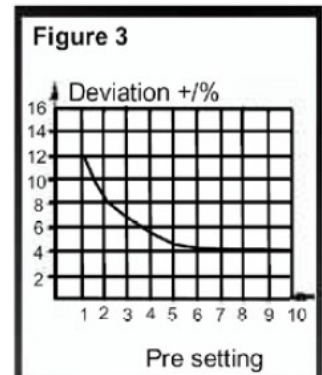

Correction for Liquids

Applies to liquids other than water. Correct the measured flow (q) by the density (Y) according to this formula. See Figure 4.

Figure 4

$$\text{Actual Flow} = \frac{qC_{BI}}{\sqrt{Y}}$$

Sizing a Balancing Valve

When the differential pressure and design flow are known, use this formula to calculate Cv value. See Figure 5.

Figure 5

$$C_v = 1.52 \frac{q}{\sqrt{\Delta p}}$$
 q in GPM, Δp in Ft. of H2O

$$C_v = \frac{q}{\sqrt{\Delta p}}$$
 q in GPM, √p in PSI