

Single Post Freestall System

J&D Manufacturing's Single Post Relax Fit and Ironside Freestall Systems give today's progressive farmer the proven features of our heavy-duty loops with the flexibility of our weld-free clamp system. The single row or head-to-head clamp system allows you to easily adjust the height of the loops so your cows can have the comfort they deserve. In today's changing world, why not invest in a freestall system that can change with the needs of the herd?

Features

Weld-free Clamp System:

- Weld-free design for system flexibility
- ¼" steel galvanized clamps
- Cross clamps and tee clamps include loop mounting hole and power tension hole for maximum stability
- Tight fitting ¼" steel control rail clamps with labor saving ½" carriage bolts and nylock nuts
- Designed for single row or head-to-head installations on wood or steel posts

Freestall Loops:

- Heavy-duty, 10-gauge, 2¾" galvanized tubing
- Relax Fit, Ironside, or Dog Bone loop design
- Relax Fit and Ironside standard sizes 5'6", 6', 6'6", 7', 7'6", 8', and 8'6"

Relax Fit

Ironside

- Dog Bone standard sizes 6', 6'6", 7', and 7'6"

Dog Bone

Control Rail:

- Available in 11 or 14-gauge, 1.9" galvanized tubing, or 10-gauge, 2¾" galvanized tubing
- Swaged on the end for easy assembly

Up-Post:

- Heavy-duty, 7-gauge, 2⅞" galvanized tubing
- Available in 60" to bolt on after concrete is poured or 72" to set in concrete allowing for 12" embedded and 60" protruding



⚠ WARNING: This product can expose you to chemicals including lead, which is known to the State of California to cause cancer and birth defects or other reproductive harm. For more information go to www.P65Warnings.ca.gov/product.

Single Post Freestall System

Single Post Components

Part #	Description
Weld Free Clamp Systems	
HF127	Mount, U-Bracket, 1/4" for 2 3/8" Post, Horiz., Single Row, w/Hdwr, HDG
HF127HH	Mount, U-Bracket, 1/4" for 2 3/8" Post, Horiz., Double Row, w/Hdwr, HDG
HF2323-3	Clamp, Tee w/Flange, 2 3/8" x 2 3/8", w/Hardware, HDG
HF2327-3	Clamp, Tee w/Flange, 2 3/8" X 2 7/8", w/Hardware, HDG
HF232323	Clamp, Cross, 2 3/8" X 2 3/8" X 2 3/8", w/Hardware, HDG
HF232723	Clamp, Cross, 2 3/8" X 2 7/8" X 2 3/8", w/Hardware, HDG
HF238U	Bracket, U for Wood or Metal Post 2 3/8", w/Hdwr, HDG (Set of 2)
HF3025	Clamp, U-Bolt Cross, 3" x 2 1/2", w/Hardware, Painted
HF819HV2	Mount, Horizontal/Vertical Pipe, for 2 3/8", w/Hdwr, HDG (Set of 2)
HF919HV	Mount, Horizontal/Vertical Pipe, for 1.9", w/Hdwr, HDG (Set of 2)
Control Rail	
TR1911	Control Rail, 1.9", 11 gauge, 288", Galvanized, Swaged
TR2375	Control Rail, 2 3/8", 10 gauge, 288", Galvanized, Swaged
HF42AB	Clamp, Control Rail 1.9" x 2 3/8", 1/4" HDG, Steel, with 1/2" Bolts
HF42B	Clamp, Control Rail 2 3/8" x 2 3/8", 1/4" Steel, HDG, with 1/2" Bolts
HF43*	2-Bolt Clamp, Control Rail 1.9" x 2 3/8", Cast Iron, HDG, with 1/2" Bolts
Up-Posts for Stall Systems	
HF27860	Up-Post, 2 7/8" X 59", Bolt Mount, HDG
HF27872	Up-Post, 2 7/8" x 72" (60" above cement), Cement-In, Galvanized

*Must be retightened 3 months after initial install, and yearly thereafter

See our Brisket Systems literature for all your brisket needs.
Bundle pricing is available on control rails.

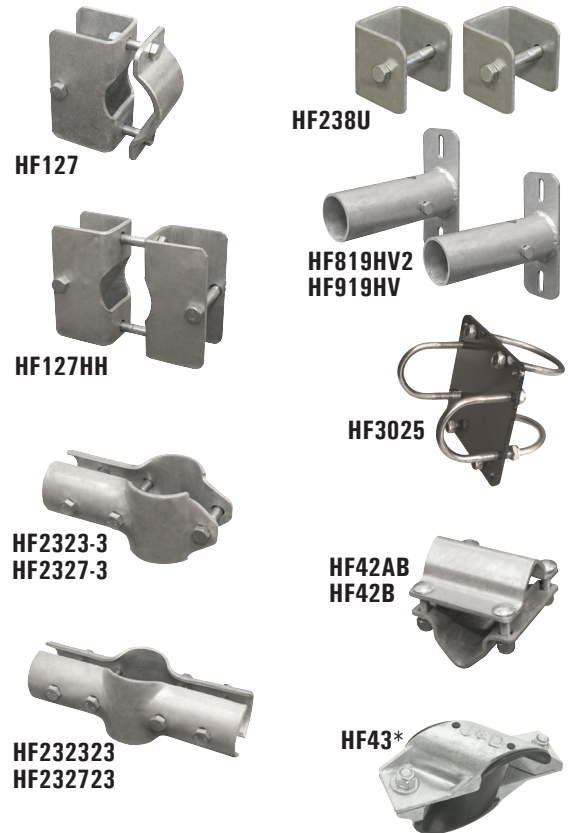

Galvanized Cow Loops - 2 3/8" OD - 10-Gauge

Ironside Loops

Part#	Length
TF856-H	5'6"
TF860-H	6'0"
TF866-H	6'6"
TF800-H	7'0"
TF876-H	7'6"
TF880-H	8'0"
TF886-H	8'6"

Relax Fit Loops

Part#	Length
TFY856-H	5'6"
TFY860-H	6'0"
TFY866-H	6'6"
TFY870-H	7'0"
TFY876-H	7'6"
TFY880-H	8'0"
TFY886-H	8'6"

Dog Bone Loops

Part#	Length
TFD860	6'0"
TFD866	6'6"
TFD800	7'0"
TFD876	7'6"

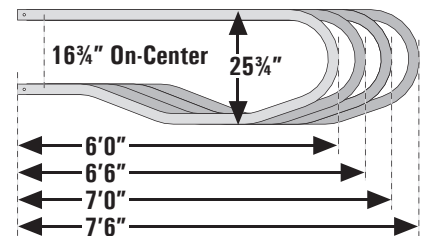
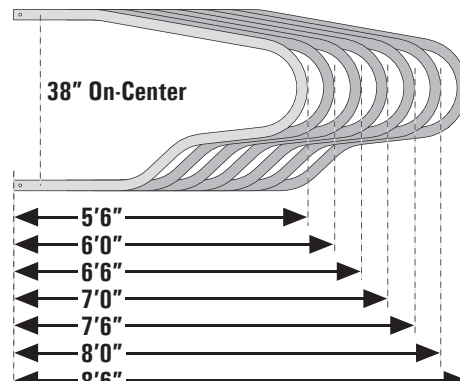
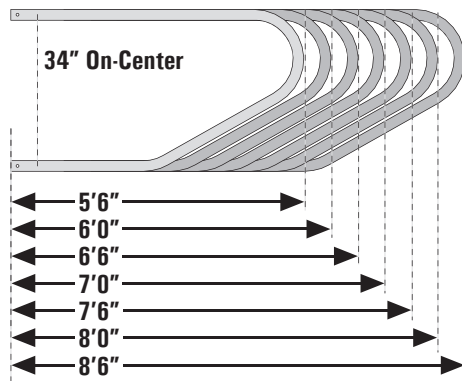

1.9" loops and components are available.
Contact your J&D representative for more information.

⚠ WARNING: This product can expose you to chemicals including lead, which is known to the State of California to cause cancer and birth defects or other reproductive harm. For more information go to www.P65Warnings.ca.gov/product.