

## CONTINUOUS INTERLOCK FATIGUE MAT SYSTEM

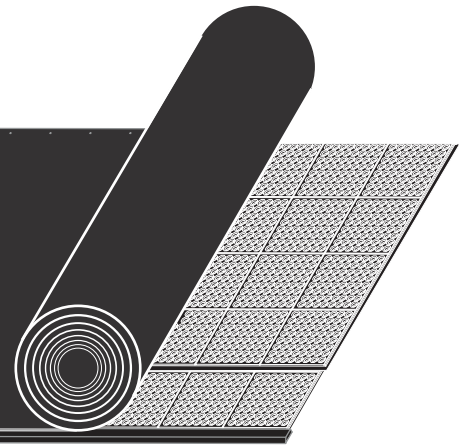

## WARRANTY

J&D Manufacturing warrants all products are free from defects in materials and workmanship under normal use for the period of one year from date of purchase. Our warranty does not cover normal or regular wear and tear. J&D Manufacturing can repair or replace at our option, any product or part of the product that is found to be defective. Our warranty applies to materials only, and does not include return freight, delivery, loss or damage to personal property, cost of removal or installation, any incidental or consequential damages or labor. This warranty does not apply to products which are misused, abused, altered, improperly installed or subject to negligence. All warranties must be approved through our warranty department. The original purchaser must present a copy of the invoice for the defective product. One year is our standard warranty unless specified on our literature or in the installation instructions or user manuals.

## RECOMMENDED TOOLS FOR INSTALLATION & ASSEMBLY (NOT PROVIDED)

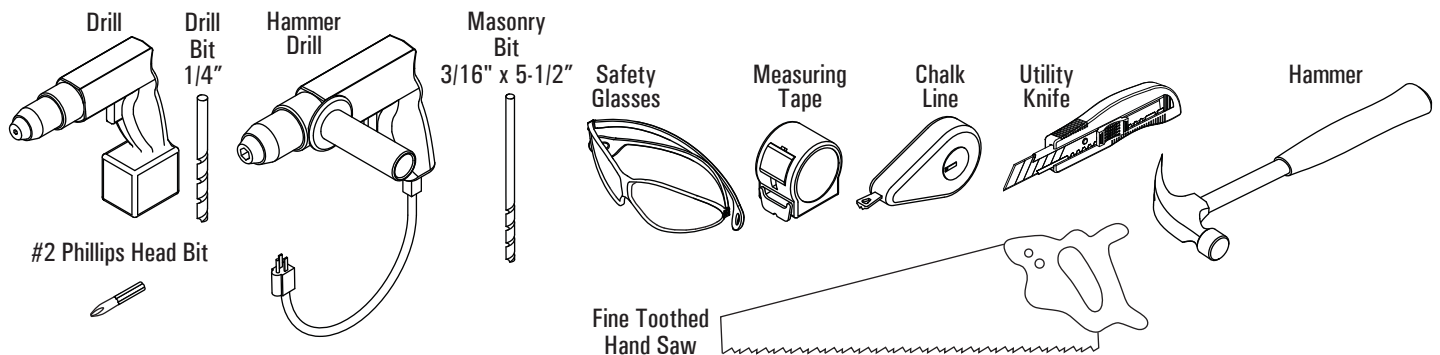

## INSTALLATION HARDWARE - TO SCALE

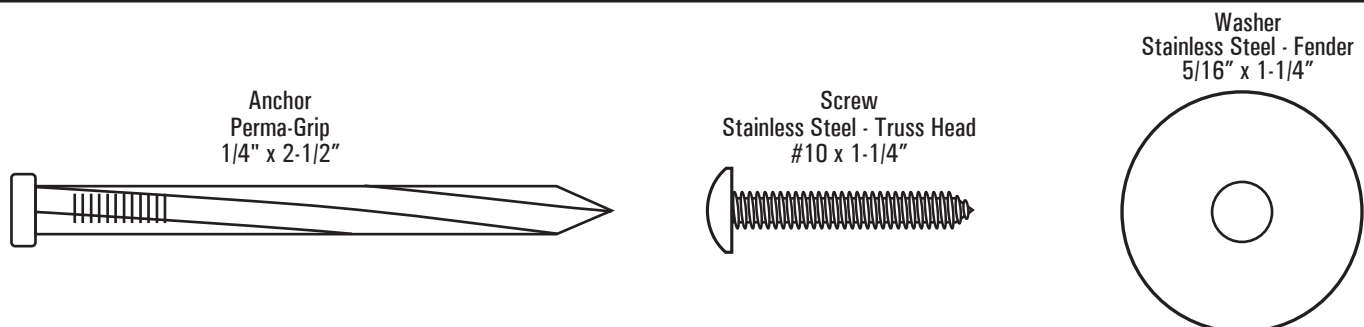

# PARTS LEGEND

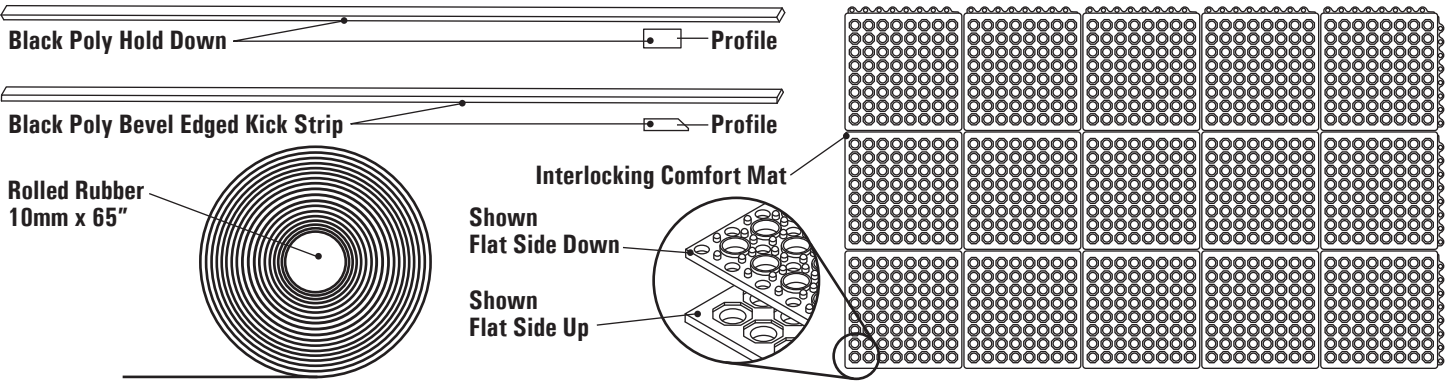

# INSTALLATION

Please read over all instructions carefully before you begin.  
If you have any questions please call your local dealer, or contact J&D Manufacturing at 1-800-998-2398.

Prepare the beveled poly kick strips for installation. Lay each kick strip on a flat surface as shown. Measure 1" in from the long square edge and use chalk line to mark entire length to assist in placement of installation hardware. Continue preparation by marking entire length in 24" increments and then mark 1/2" from each end. At the intersection of these horizontal and vertical marks, drill a hole through the kick strip using a 1/4" drill bit.

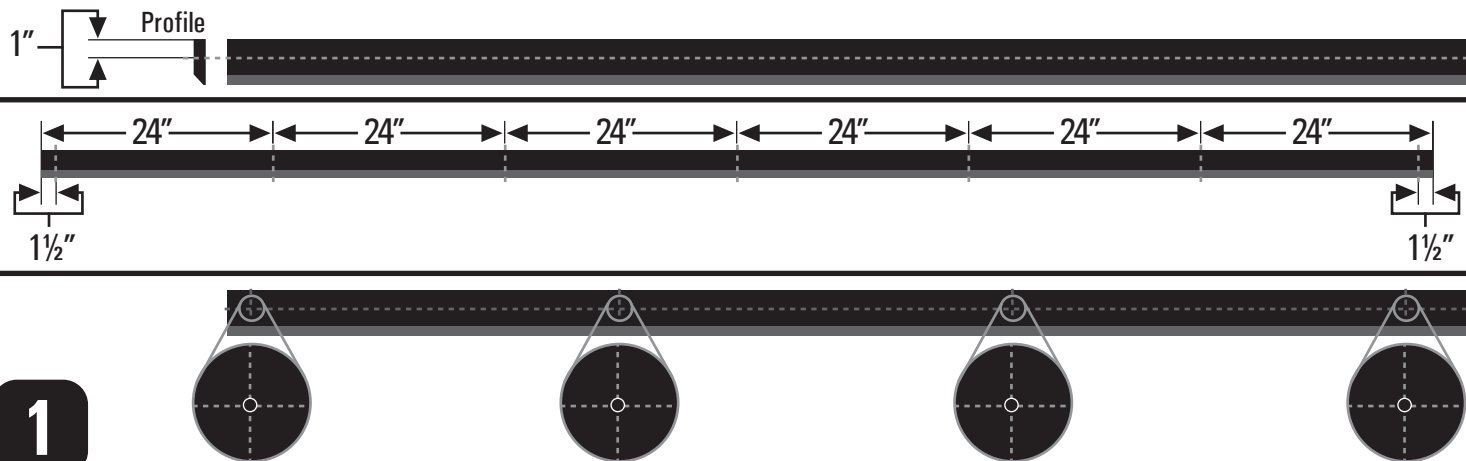

Prepare the poly hold downs for installation. Lay each hold down on a flat surface as shown. Measure 3/4" in from the long square edge and use chalk line to mark entire length to assist in placement of installation hardware. Continue preparation by marking entire length in 24" increments and then mark 1/2" from each end. At the intersection of these horizontal and vertical marks, drill a hole through the kick strip using a 1/4" drill bit.

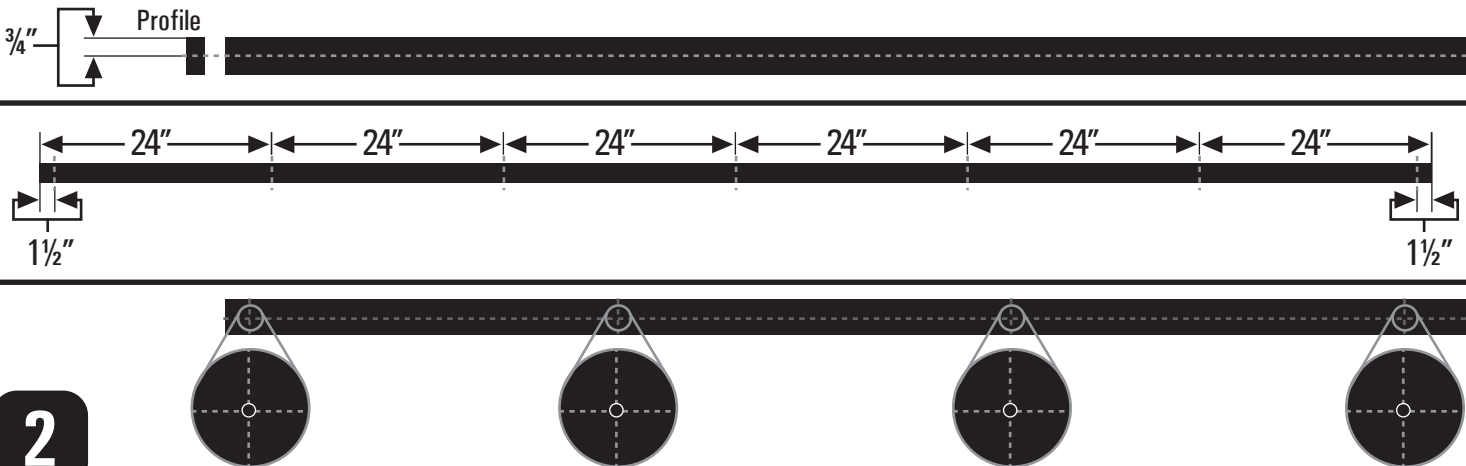

Measure  $\frac{1}{2}$ " from the curb edge. Use chalk line to mark entire length to indicate placement of poly kick strips.

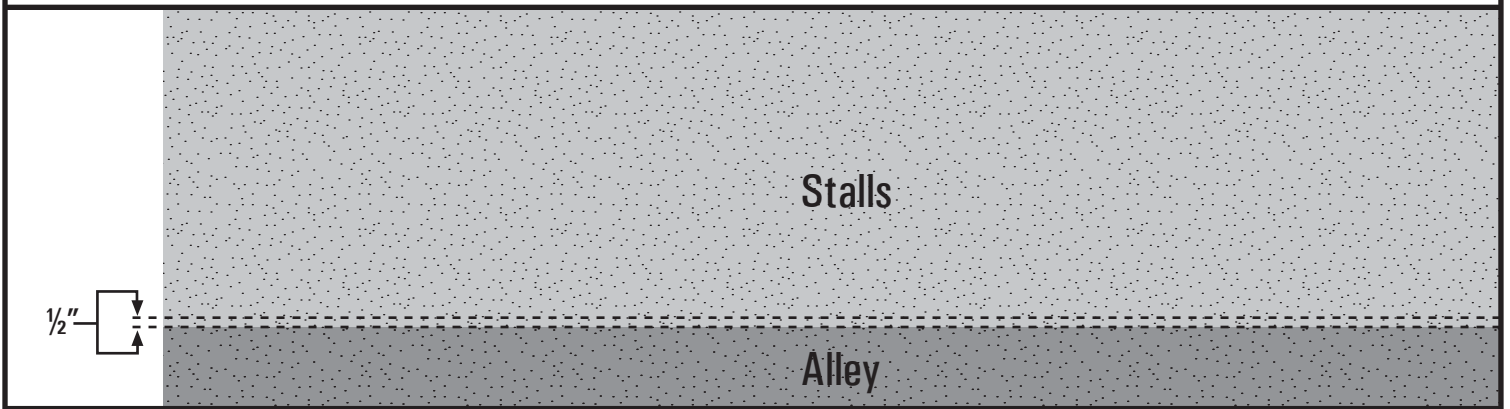

Lay out the poly kick strips with the beveled edge aligning with the marks made in **Step 3** above.

Using a  $\frac{3}{16}$ " x 5- $\frac{1}{2}$ " masonry bit and the pre-drilled holes in the poly kick strip made in **Step 1** as your guide, drill a hole into cement. Total hole depth should be 3- $\frac{1}{2}$ " from the kick strip surface to bottom of hole. Secure poly kick strip to cement by inserting a perma-grip anchor and seating it fully with a hammer. Repeat for each hole until all kick strips are fully installed. As you work your way across, make sure that the beveled edge of the kick strip stays aligned with your chalk line.

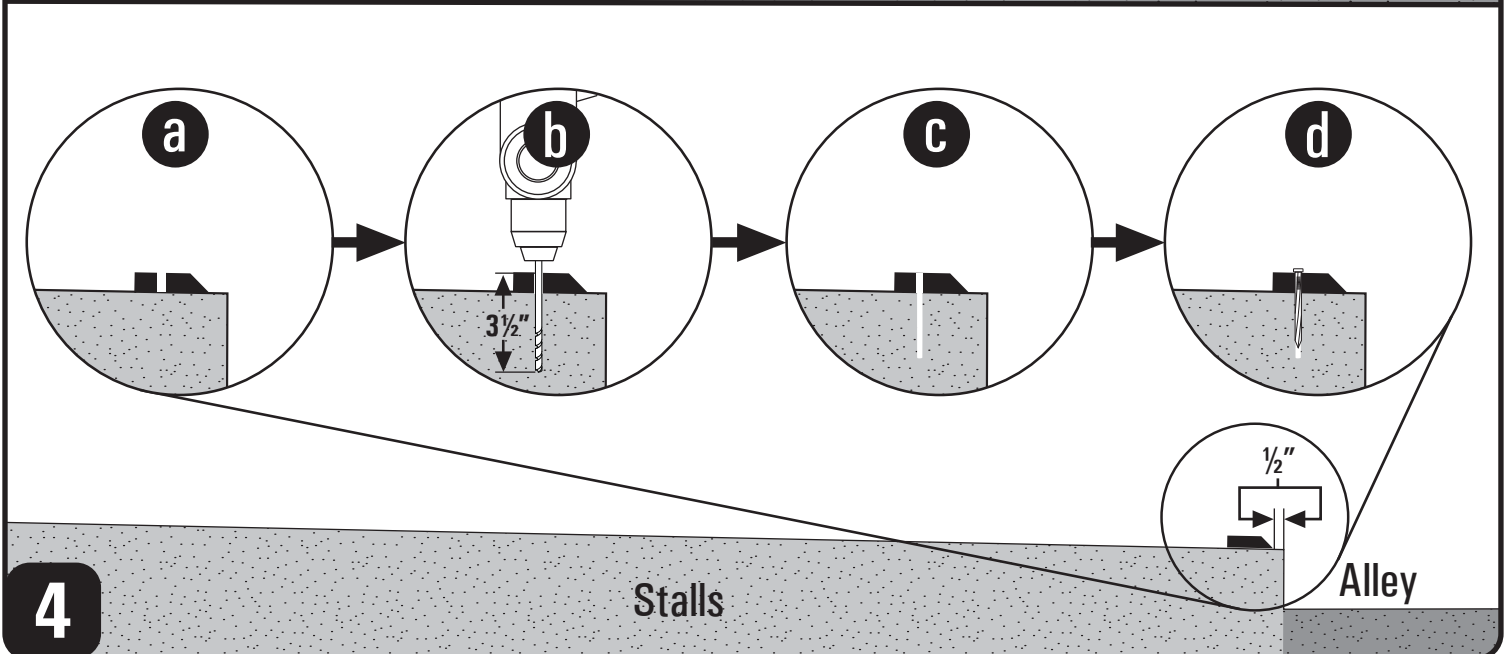
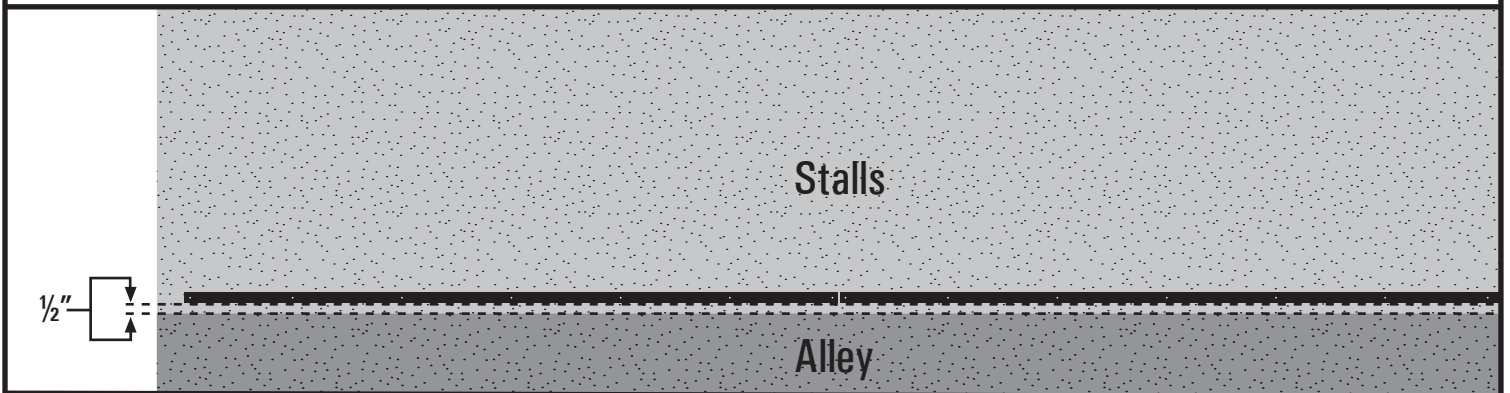

Once the kick strip has been installed, measure 61-3/4" from the square edge of the kick strip towards the head area of the stall as shown below. Use chalk line to mark entire length to indicate placement of the poly hold downs.

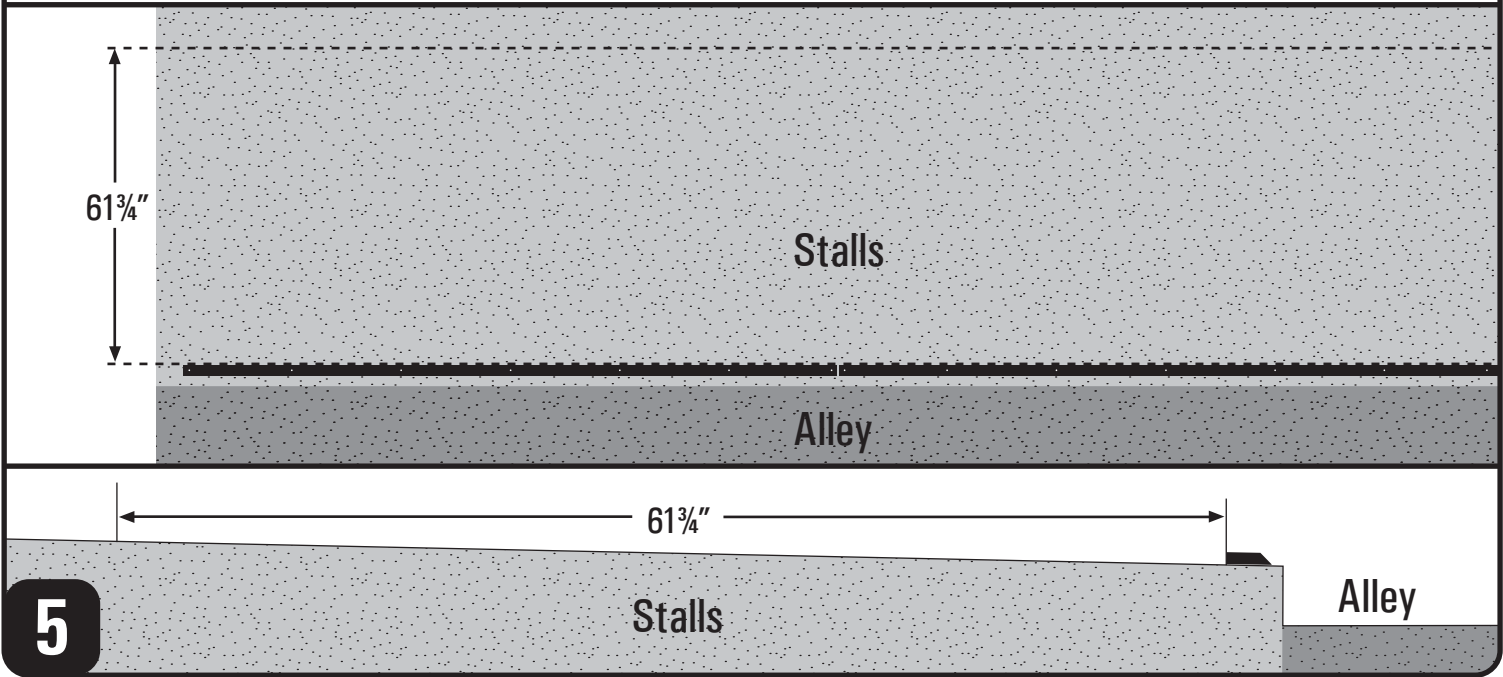

Lay out the poly hold downs aligning edge with the marks made in **Step 5** above.

Using a 3/16" x 5-1/2" masonry bit and the pre-drilled holes in the poly hold down made in **Step 2** as your guide, drill hole into cement. Total hole depth should be 3-1/2" from the hold down surface to bottom of hole. Secure poly hold down to cement by inserting a perma-grip anchor and seating it fully with a hammer. Repeat for each hole until fully installed. As you work your way across, make sure that the edge of the hold down stays aligned with your chalk line.

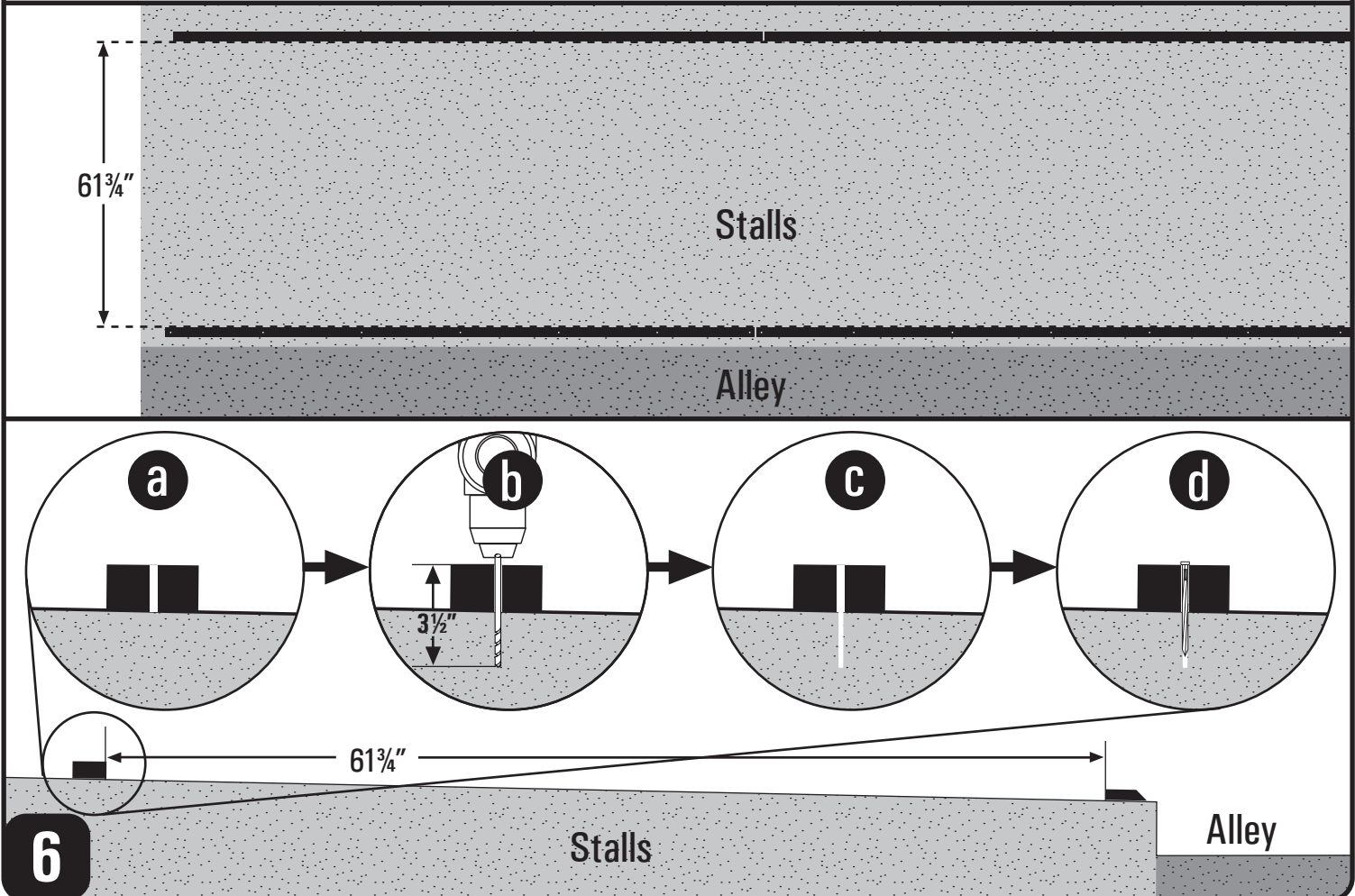

Take one of the hold downs prepared previously in **Step 2**. Measure 61-3/4" from each end and cut at both marks. You will now have two 61-3/4" pieces and a scrap piece which can be discarded. Measure 1-1/2" from the newly cut end of each 61-3/4" pieces. Drill a hole through the hold down using a 1/4" drill bit at the intersection of the new line and the horizontal line marked previously.

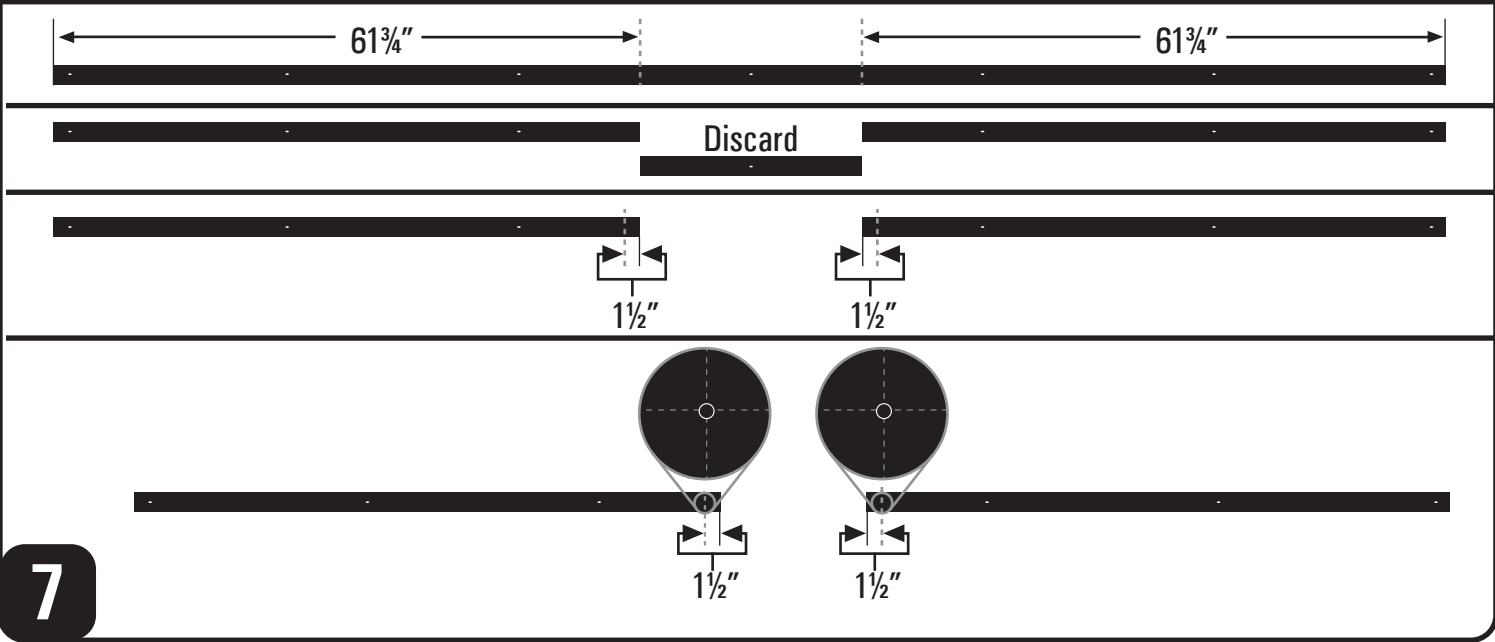

Arrange the poly hold down end pieces prepared in **Step 7** between the previously installed hold down and kick strip as shown below.

Using a 3/16" x 5-1/2" masonry bit and the pre-drilled holes made in **Step 2 and 7** as your guide, drill hole into cement. Total hole depth should be 3-1/2" from the hold down surface to bottom of hole. Secure poly hold down to cement by inserting a perma-grip anchor and seating it fully with a hammer. Repeat for each hole until fully installed.

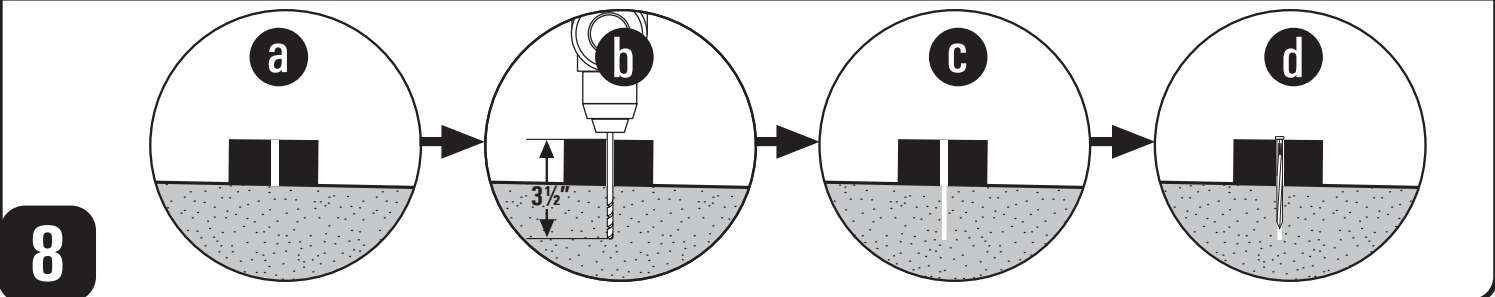
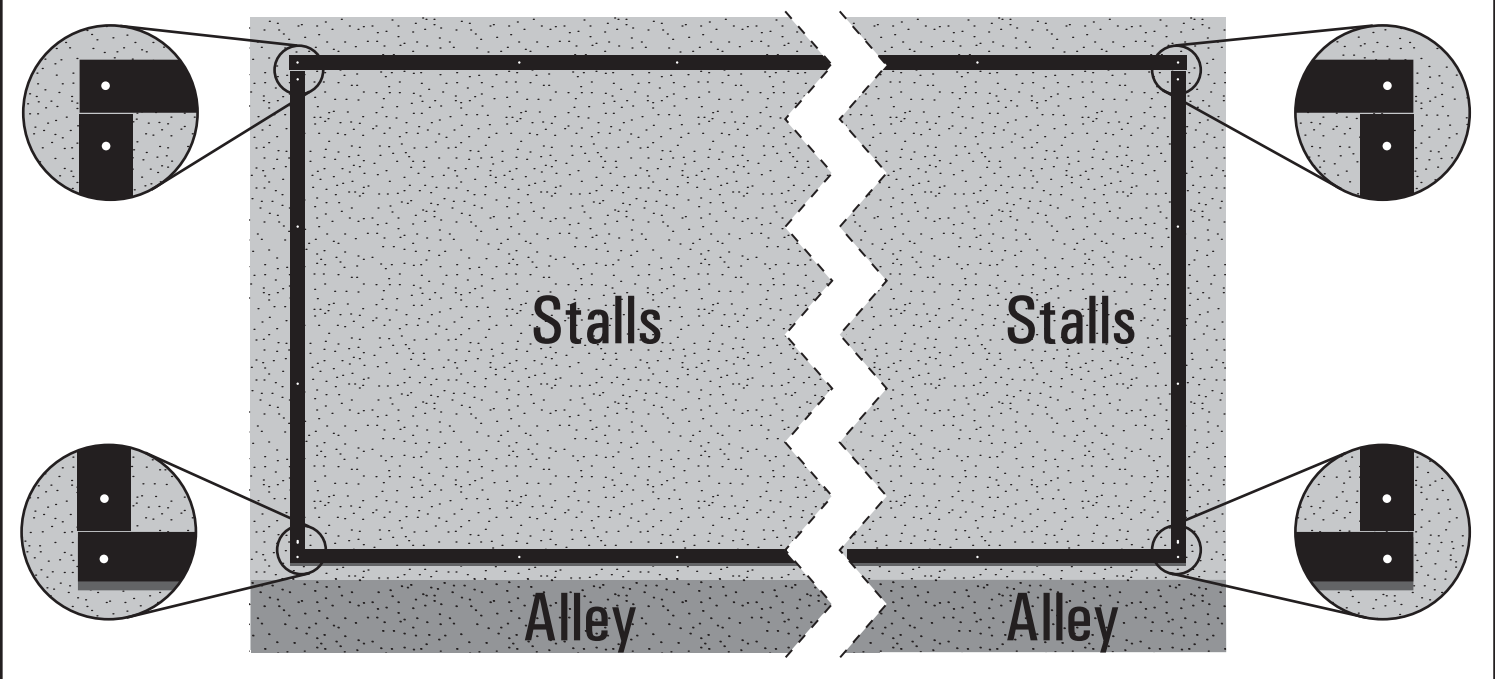

Install first layer of interlocking comfort mat. Lay down first interlocking mat with flat side up and straight edges pushed flush with kick strip on alley side and side hold down. Once the first interlocking mat is properly placed, lay down remaining mats and interlock mats together.

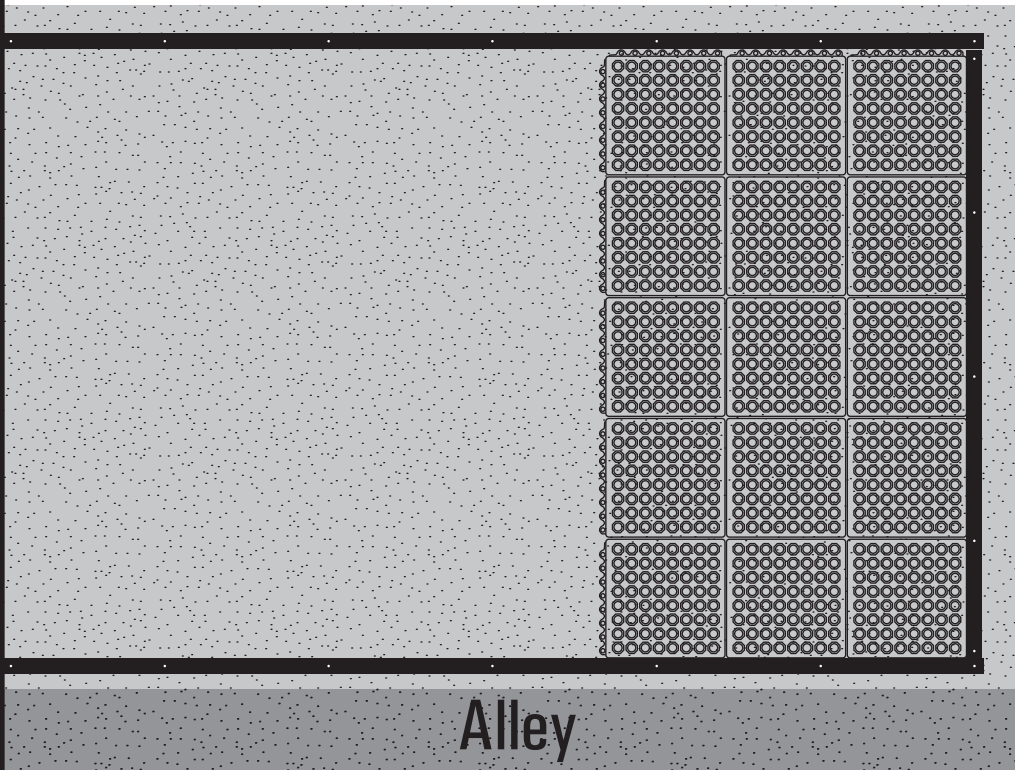

Flat Side Up

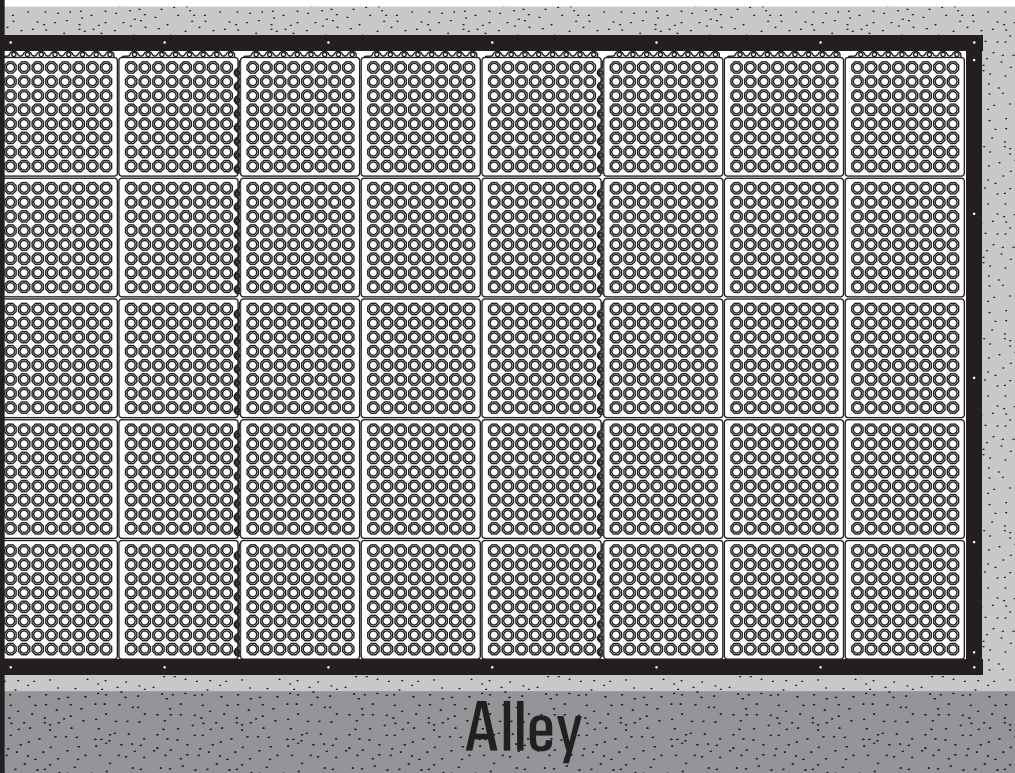
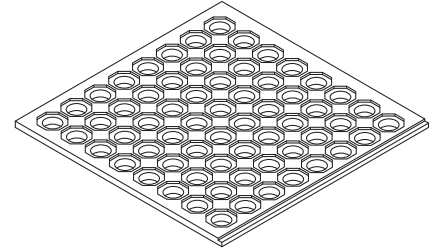

Flat Side Up

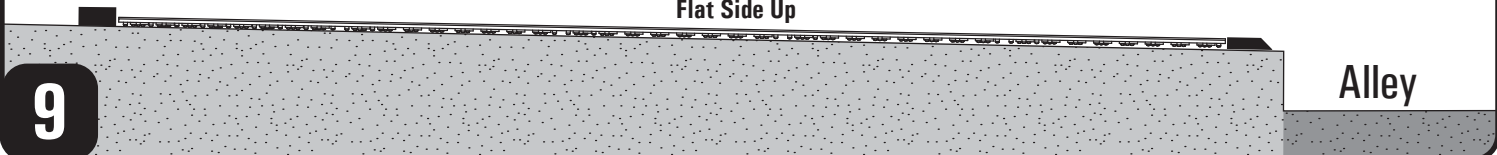

9

Prepare the second layer of interlocking mats by cutting off the bottom three squares of the five square by three square mat.

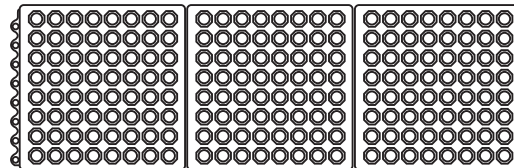
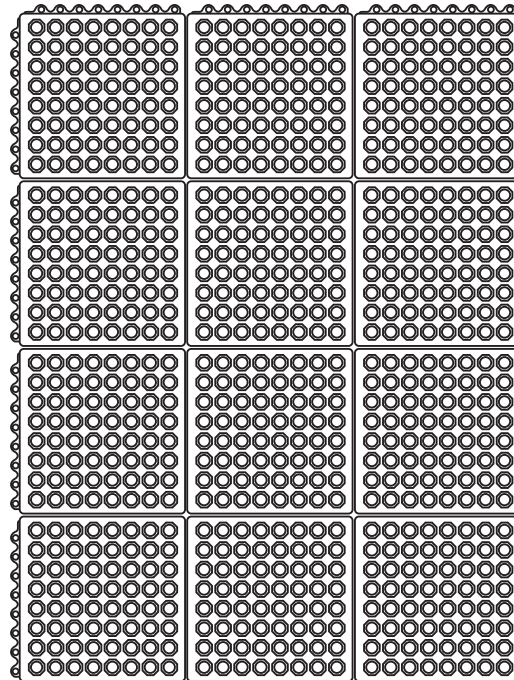
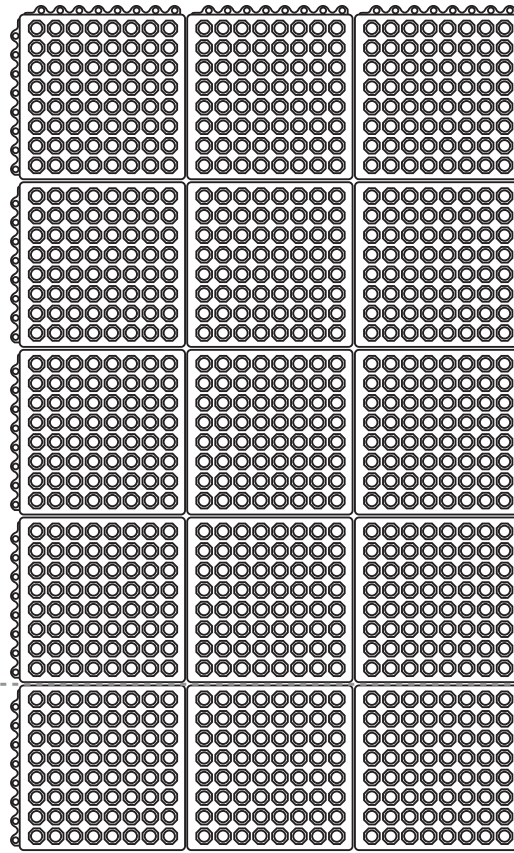

—Discard

10

Install second layer of interlocking comfort mats with flat side down. Second layer should be aligned with the hold down in the brisket area of the stall with seams offset from the first layer seams. Once the first interlocking mat is properly placed, lay down remaining mats and interlock mats together as shown below. Trim end pieces to fit remaining space from edge of interlock mat to side hold downs. For 3 layer system, repeat **Step 10** to trim mats. Install third layer flat side up and install as shown in **Step 11** making sure to offset seams from 1st and 2nd layers.

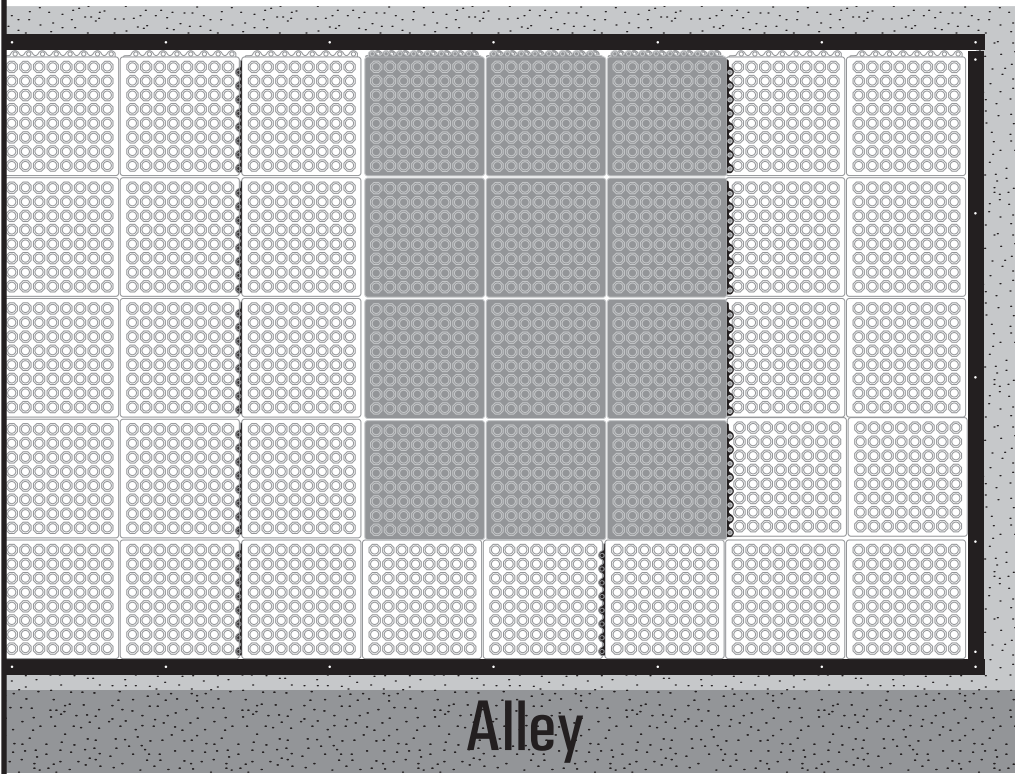

Flat Side Down

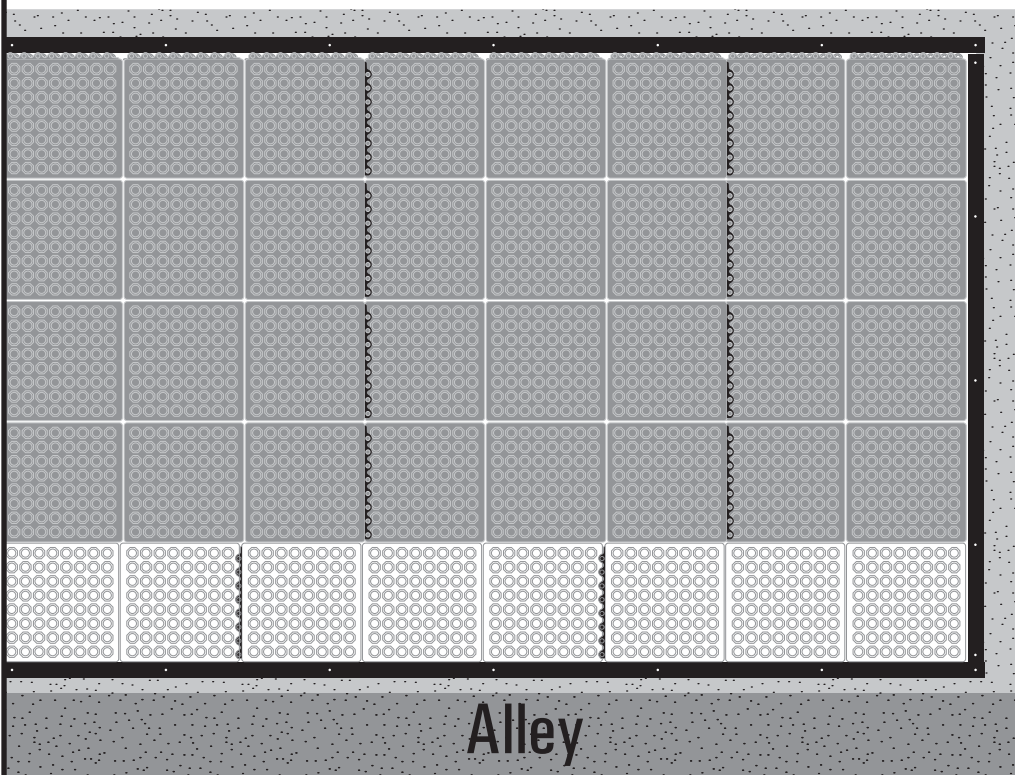
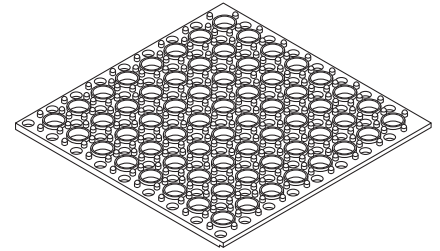

Flat Side Down

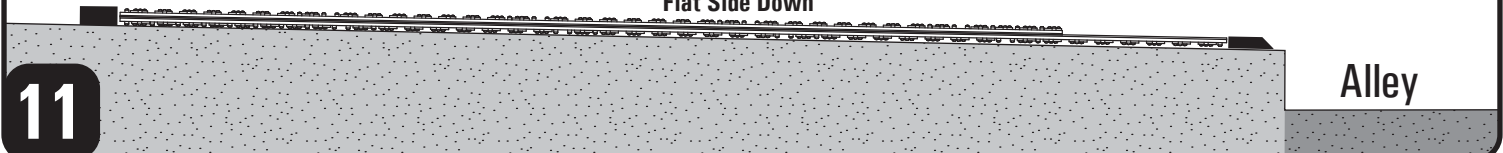

11

Once all interlocking mats are installed, roll out the rolled rubber on top of the stall area. Rubber needs to come to room temperature (at least 60°F) and relax for 48 hours before securing.

Leave rolled rubber unrolled at  
60°F + for 48 Hours

Alley

### 2 Layer Fatigue Mat System

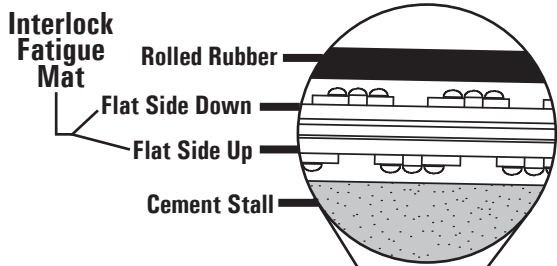

12

Alley

### 3 Layer Fatigue Mat System

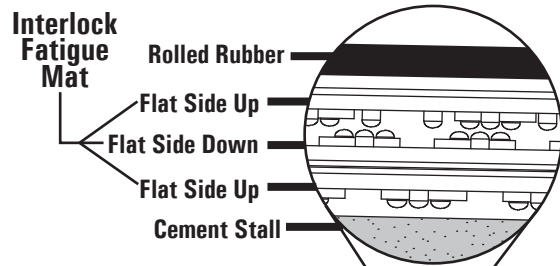

Alley

After rubber has been allowed to rest, measure 1" from brisket edge and 1" from each side. Use a chalk line to mark entire length and width of the rolled rubber as shown below. Starting in the corner, begin securing rolled rubber to the poly hold downs using a drill and #2 Phillips head bit. Secure corner of mat with #10 x 1-1/4" Stainless Steel Truss Head Screw and 5/16" x 1-1/4" Stainless Steel Fender Washer.

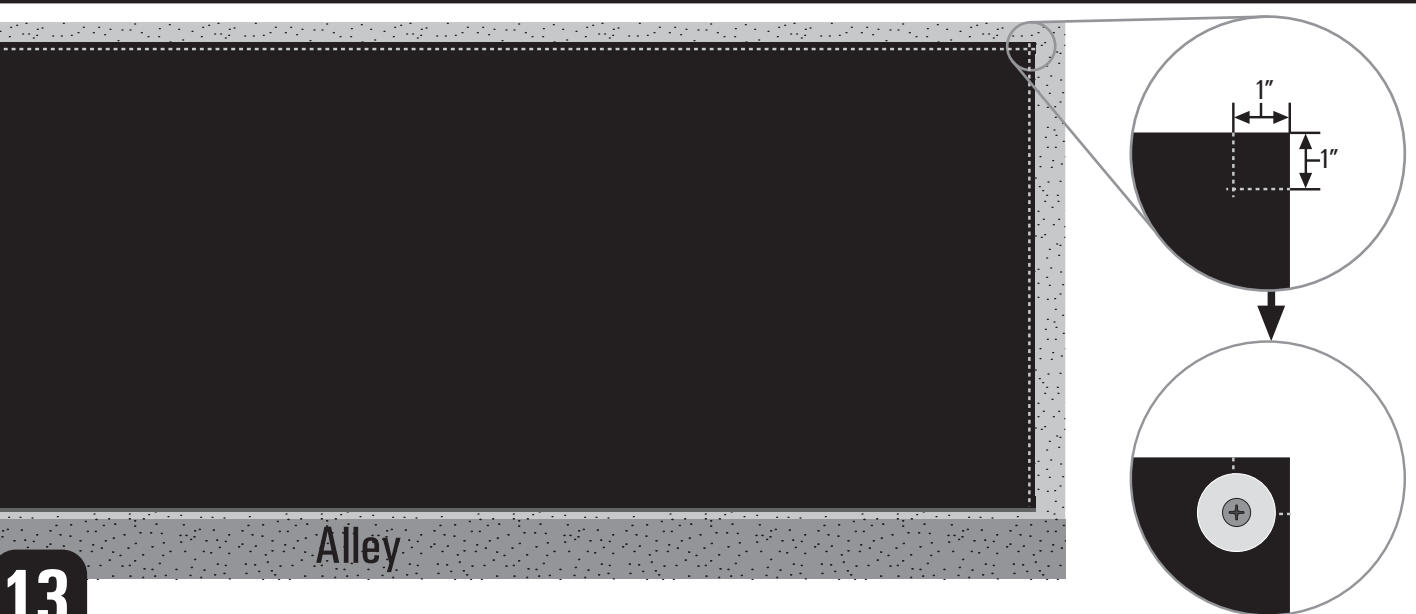

13

Alley

Starting your measurements from the first screw (**NOT** the rolled rubber edge), measure and mark every 8" across the brisket edge and down the starting side. Secure the short edge of the poly hold down first by pulling the rolled rubber so it lays flat. Install the rolled rubber to the poly hold downs using a #2 Phillips head bit to secure #10 x 1-1/4" Stainless Steel Truss Head Screw and 5/16" x 1-1/4" Stainless Steel Fender Washer at every 8" increment. You must stay in line with the previously marked chalk line while keeping the rolled rubber even with the hold down edge. Finish end by marking 1" from rubber edge and secure as mentioned above.

Once starting end is secure, continue this process across the entire length of the brisket edge of your installation until you reach the other end poly hold down. Finish installation by using the same measurements and instructions used on the starting end for the finishing end as described above.

**Do NOT screw down or otherwise fasten the rolled rubber on the alley edge.** The weight of the rolled rubber and the securing on the brisket and side edges will discourage lifting and movement. Hardware installed on this edge can cause animal discomfort and injury.

