

High Pressure Fog System



HPF Stainless Steel Lines
with 12", 18", 24", or 48"
Nozzle Spacing

- Reduces temperatures quickly and uniformly with minimal energy use
- Minimizes heat stress which improves feed conversion for increased production
- Easy to retrofit your current ventilation system
- Made from corrosion resistant materials for long life
- Anti-drip brass nozzles with end of line auto drain valve help keep your floor dry
- Reduces heat stress mortalities



HPF Stainless Steel
Panel Fan Ring Kit
with 12 Nozzles



Table of Contents

A: Warranty & Recommended Tools	N: Connecting Pump to Filter and Fogging System/s
B: Water Quality Requirements	O: Flushing System
C: Pump & Filter Kit Location Requirements & Recommendations	P: Filter Installation
D: Parts Identification	Q: Nozzle Installation
E: Guidelines for Assembling Components	R: Test & Adjust System
F: Filter System Assembly & Installation	S: Maintenance
G: Motor/Pump Shelf Assembly & Installation	T: End of Season & Winterizing
H: Motor & Pump Assembly & Installation	U: Maintenance Checklist
I: Hanging & Connecting Stainless Steel Lines	
J: J&D Panel Fan Ring Kit Installation	
K: Ring Kit Installation for (36" and Larger) Basket Fans	
L: Cross Kits Installation for Basket Fans	
M: Auto Drain Kit Installation & Assembly	

WARRANTY

One year is our standard warranty unless specified on our literature or in the installation instructions/user manuals, for pump warranty see pump manual.

J&D Mfg. warrants all products are free from defects in materials and workmanship under normal use for the period of one year from date of purchase, warranty does not cover normal or regular wear and tear. J&D Mfg can repair or replace at our option, any product or part of the product that is found to be defective. Our warranty applies to materials only and does not include return freight, delivery, loss or damage to personal property, cost of removal or installation, any incidental or consequential damages or labor. This warranty does not apply to products which are misused, abused, altered, improperly installed or subject to negligence. All warranties must be approved through our warranty department. The original purchaser must present a copy of the invoice for the defective product.

RECOMMENDED TOOLS & SUPPLIES FOR INSTALLATION AND ASSEMBLY (NOT PROVIDED)

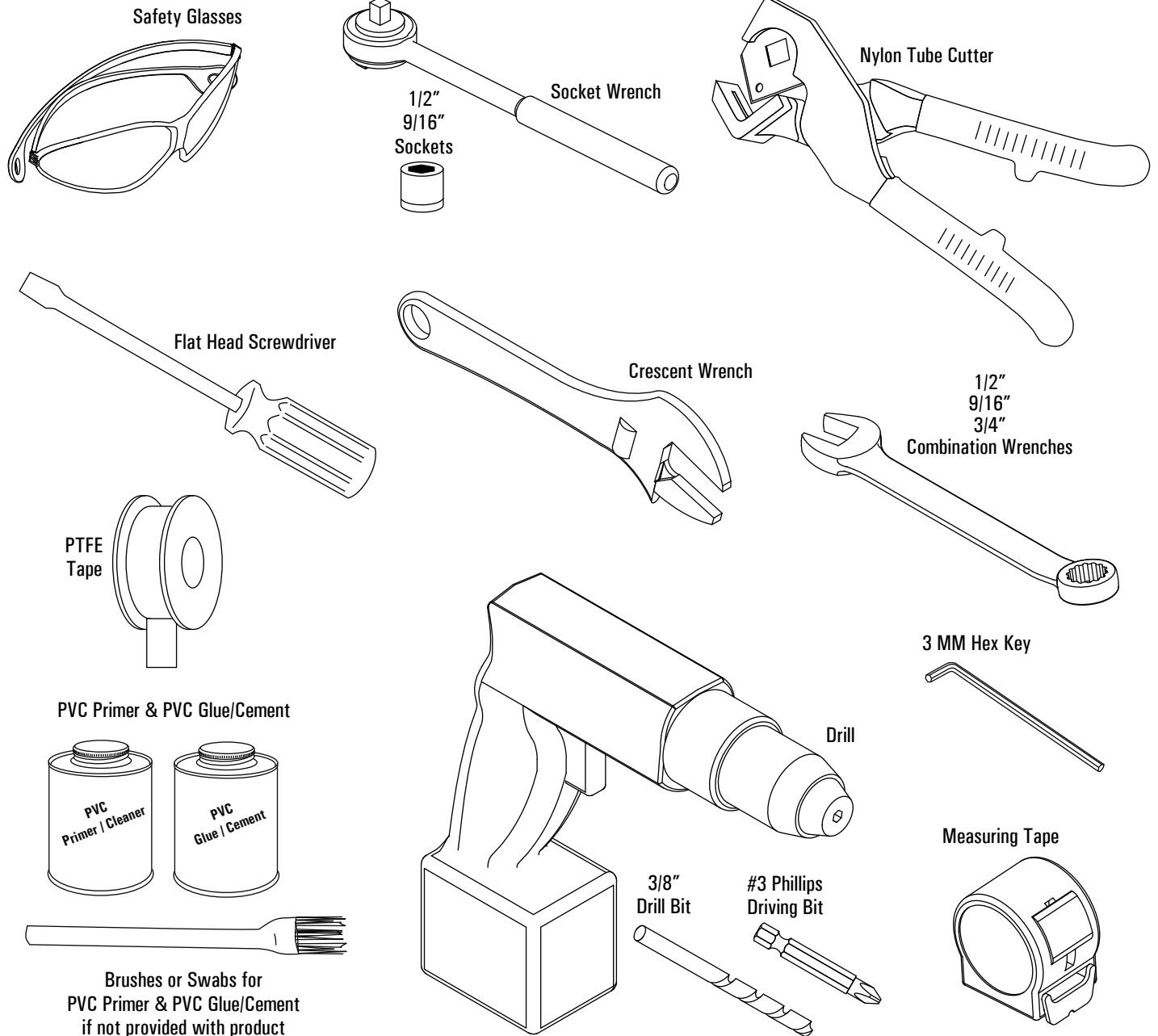

INSTALLATION

Please read over all instructions carefully before you begin. If you have any questions please call your local dealer, or contact J&D Manufacturing at 1-800-998-2398.

Water Quality Requirements

Thorough water testing and treatment of your intended water supply by qualified water treatment professionals is required to minimize mineral deposits and corrosion that may block or erode nozzles.

Shown are the basic parameters required of your water supply.

Additional requirements by your water treatment professionals may be justified.

Damage or clogging of nozzles or other elements of J&D's High Pressure Fogging system due to insufficiently treated water will not be covered by warranty.

Test	Required Parameters
Hardness	Less than 7gpg (120 parts per million or milligrams per liter)
PH	7.0 or higher
Dissolved Metals	Listed are the most common and problematic. <i>Consult with your water specialist on what additional dissolved metals you may need to correct.</i> <u>Iron</u> - Less than 0.3 parts per million <u>Manganese</u> - Less than 0.05 parts per million
TDS (Total Dissolved Solids)	Less than 500 milligrams per liter

Filter & Motor Space Requirements

The minimum space requirements needed for the filtration assembly are 54" in width and 37" in height

The minimum space requirements for the motor and pump shelf assembly are 31" in width and 37" in height.

Provided 3/4" x 5' Braided Hose for connecting filter assembly to pump allows for a 4' distance between the filtration assembly and the motor pump shelf assembly, however this distance can be extended if a longer (not provided) hose is acquired.

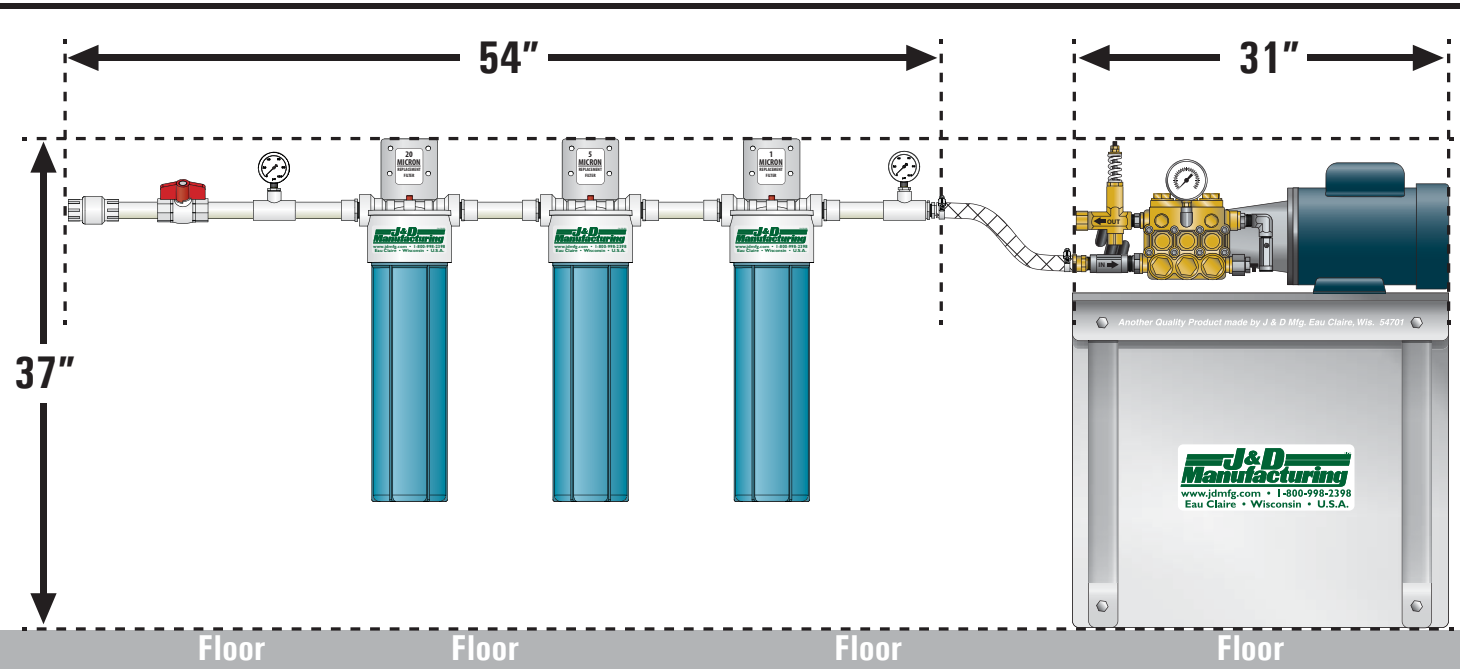

Filter & Motor Space Recommendations

Due to the nature of setup and maintenance of a filtration system, it is recommended that it be located in an area that has a floor drain or is some way protected so that water will not damage materials or structure. Additional precautions should be taken to ensure that water will not come in contact with electrical cords or outlets as this may result in severe injury or even death.

* Indicates shown to scale for ease of identification.

VHPF2520C - 3 Stage 2 1/2" Filter Kit

(6) **PP10461**
3/4"x1"
Adapter

(2) **SS0T**
1"x1"x1/2"
Tee

(1) **VHPR123**
Adapter
3/8" Slip Lock
x 3/8" MIPT

*(12) **HD10464**
Phillips Pan Head Screw
#14-10 x 3/4"

(1) **SS01**
1" Ball Valve

(2) **VHPR145**
Hose Clamp

20 MICRON
REPLACEMENT
FILTER

5 MICRON
REPLACEMENT
FILTER

1 MICRON
REPLACEMENT
FILTER

Set of 3 Filter Size Labels
for Mounting Brackets

(1) **VHPR146**
1" Spigot x
3/4" FPT
Reducer Bushing

(1) **PP10815**
Anti-Seize
Lubricant
2 Gram
Single Use
Pouch

(1) **SS03**
1" One Way
Check Valve

(1) **VHPR147**
Male Adaptor
3/4" MPT x
3/4" Insert

(3) **VHPR142**
Mounting Bracket for
2-1/2" Filter Housing

(2) **SS19**
1/2"x1/4"
Reducer

(1) **VHPR148**
Brass Adaptor
3/4" ID Barb x
3/4" Male
Hose Thread

(2) **VHPR149**
Water Supply
Low Pressure
Gauge

(1) **VHPR133**
2-1/2" Filter
Housing
Wrench

(1) **VHPR151**
1" PVC Tubing
2' Stick

(1) **VHPR152**
3/4" Braided Hose
5' Length

(1) **VHPR136**
20 Micron
2-1/2" Filter

(1) **VHPR137**
5 Micron
2-1/2" Filter

(1) **VHPR138**
1 Micron
2-1/2" Filter

(3) **SS05R**
O-Rings for
2-1/2" Filter Housing

(3) **VHPR135**
2-1/2" Filter
Housing Assembly

VHPR4520C - 3 Stage 4 1/2" Filter Kit

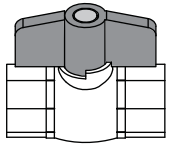

(1)
SS01
1" Ball Valve

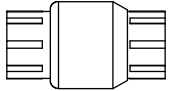

(1)
SS03
1" One Way
Check Valve



(2)
SS19
1/2"x1/4" Reducer

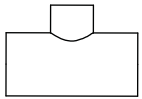

(2)
SS0T
1"x1"x1/2" Tee

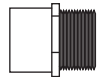

(6)
VHPR143
1"x1" Adapter

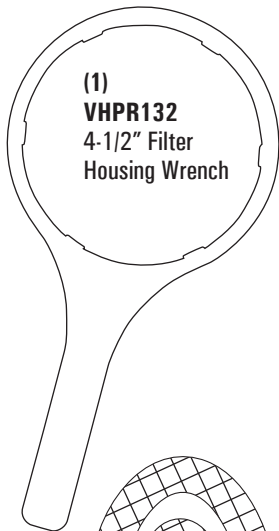

(1)
VHPR132
4-1/2" Filter
Housing Wrench

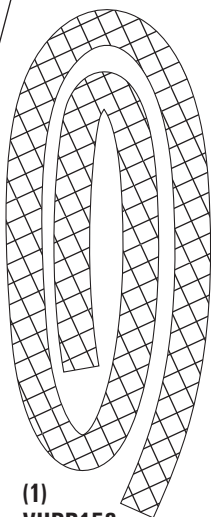

(1)
VHPR152
3/4" Braided Hose
5' Length



(1)
VHPR151
1" PVC Tubing
2' Stick



(2)
VHPR145
Hose Clamp



(1)
VHPR146
1" Spigot x 3/4" FPT
Reducer Bushing

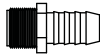

(1)
VHPR147
Male Adaptor
3/4" MPT x 3/4" Insert



(1)
VHPR148
Brass Adaptor
3/4" ID Barb x
3/4" Male Hose Thread

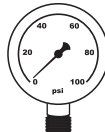

(2)
VHPR149
Water Supply
Low Pressure Gauge

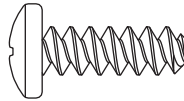

*(12)
HD10464
Phillips
Pan Head
Screw
#14-10 x 3/4"



(1) **PP10815**
Anti-Seize Lubricant
2 Gram
Single Use Pouch



(1)
VHPR123
Adapter
3/8" Slip Lock
x 3/8" MIPT

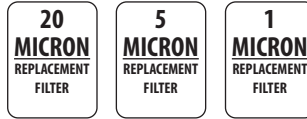

Set of 3 Labels Indicating Filter
Size for Mounting Brackets

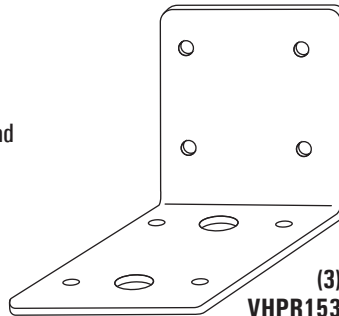

(3)
VHPR153
Mounting Bracket for
4-1/2" Filter Housing

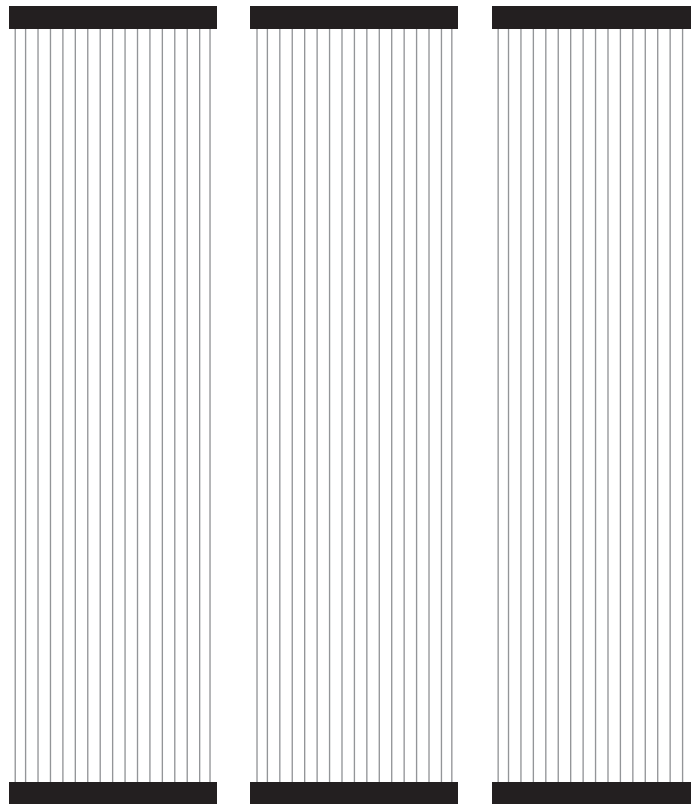

(1)
VHPR140
20 Micron
4-1/2" Filter

(1)
VHPR144
5 Micron
4-1/2" Filter

(1)
VHPR141
1 Micron
4-1/2" Filter

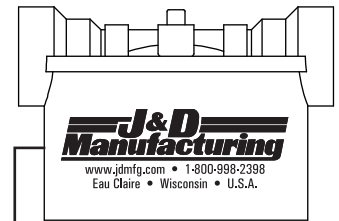

SS06R
O-Ring for
4-1/2" Filter Housing

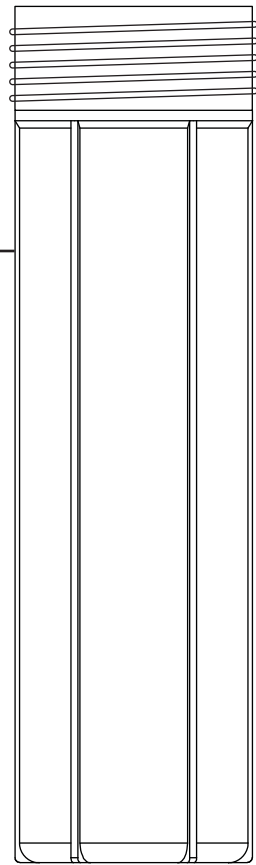

(3)
VHPR139
4-1/2" Filter
Housing Assembly

VHPRSHELF - Shelf for Motor and Pump

(1) Shelf

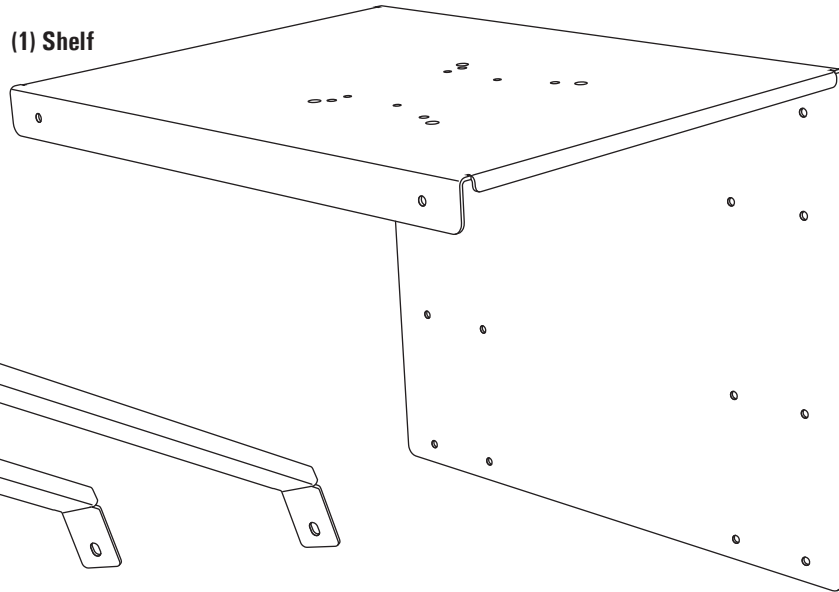

(2) Support Brackets

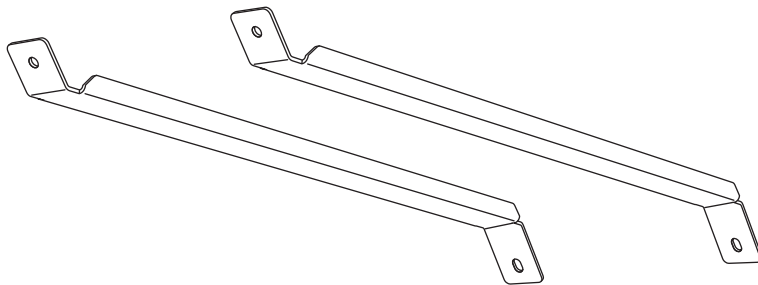

Hardware Packet Contents

(1) Large J&D Manufacturing Label



(1) Narrow J&D Manufacturing Label

Another Quality Product made by J & D Mfg. Eau Claire, Wis. 54701

Attaching Top of Brackets to Shelf

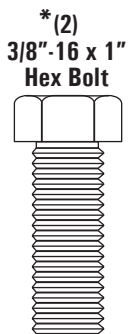

Attaching Pump to Motor

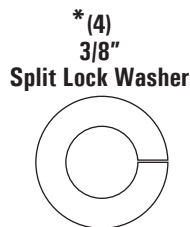
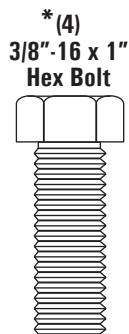

Mounting Motor to Shelf

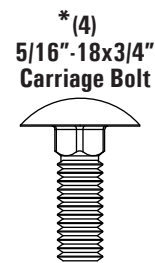
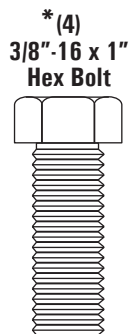

C-Face Motors

Each model of J&D C-Face pump motors will vary in size, configuration of components, and appearance, however, the functionality and purpose of the components remain the same.

Single Phase

- VHPM1
- VHPM2
- VHPM3
- VHPM5

3 Phase

- VHPM13
- VHPM33A
- VHPM53
- VHPM103-CFACE

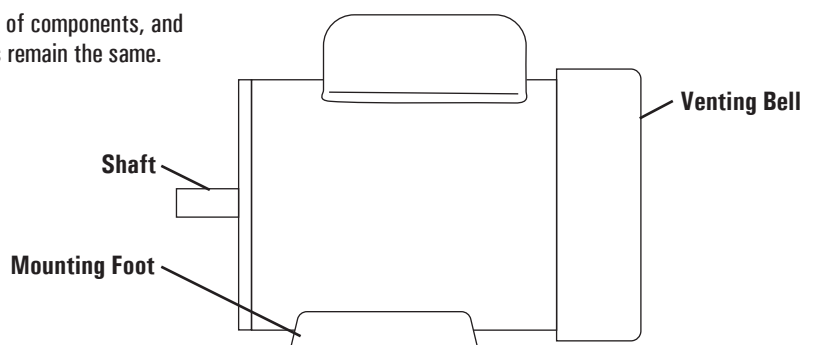

Pumps

Each model of J&D pumps will vary in size, configuration of components, and appearance, however, the functionality and purpose of the components remain the same. For detailed pump information please refer to the separate pump manual.

VHPP13 VHPP30

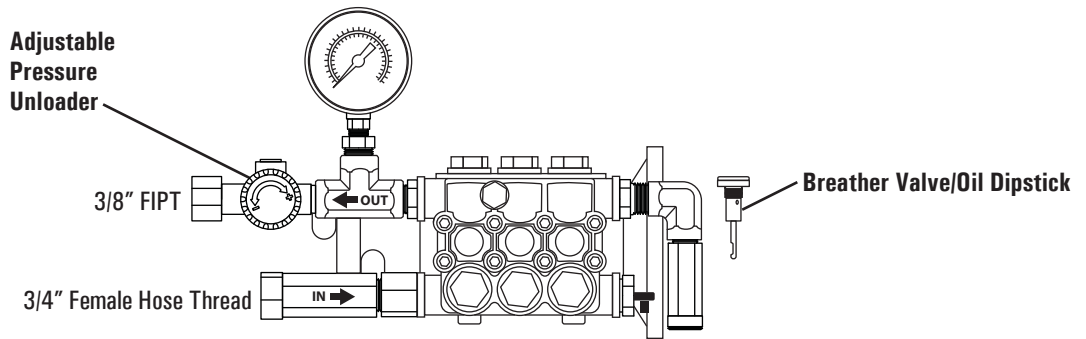

VHPP41

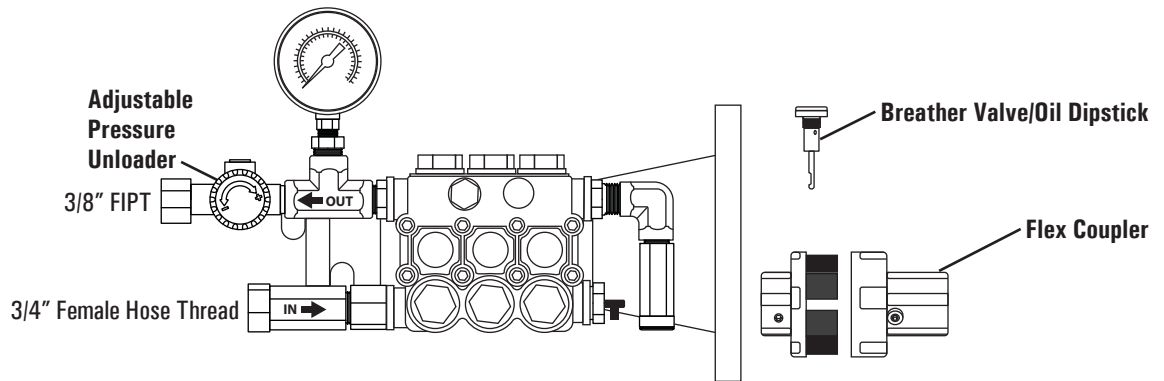

VHPP57

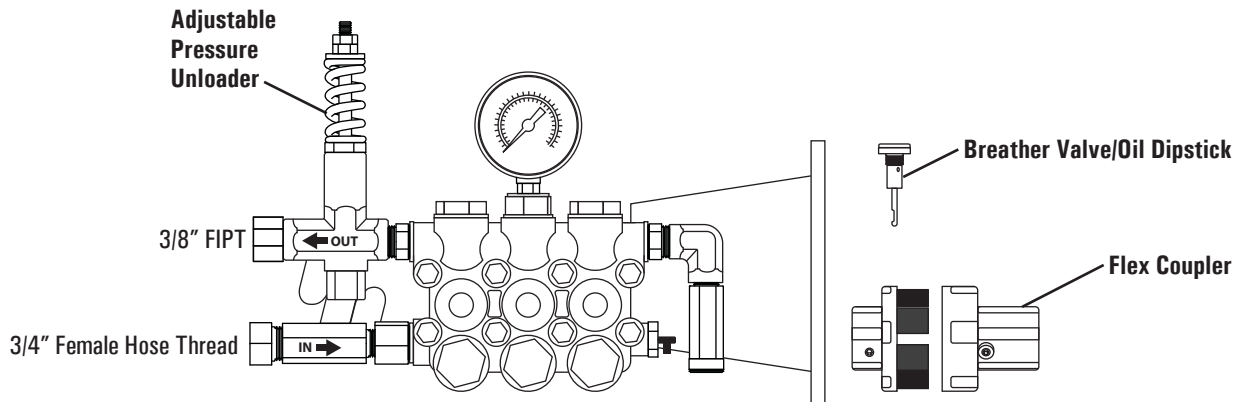

VHPP137

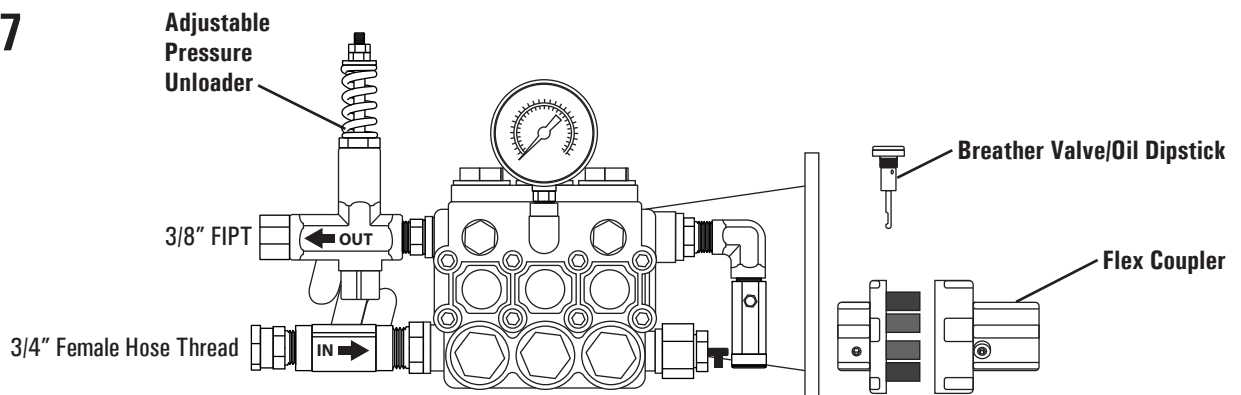

3/8" Slip Lock Connectors Compatible with VHPR122 High Pressure Nylon Tube

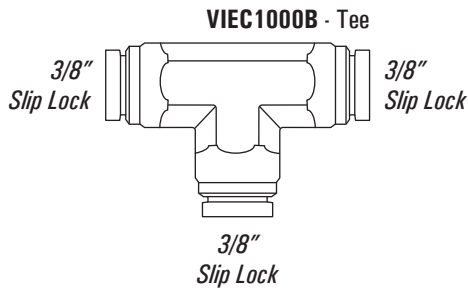
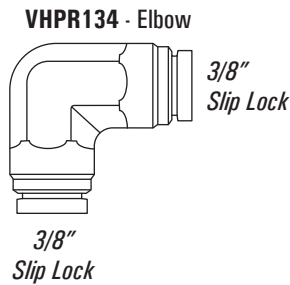
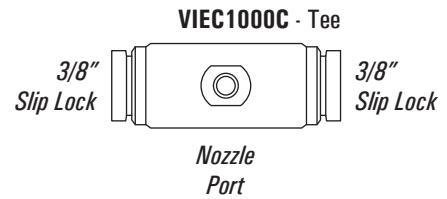
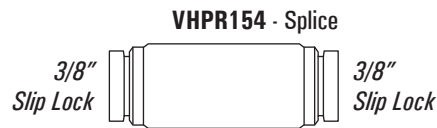
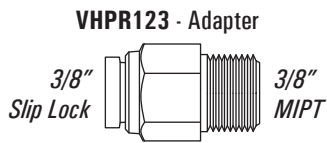

1/2" Flare Connectors Compatible with VHPR000, VHPR002, VHPR003 Stainless Steel Lines

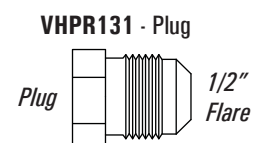
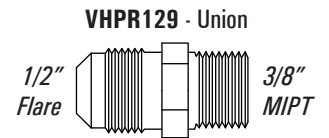
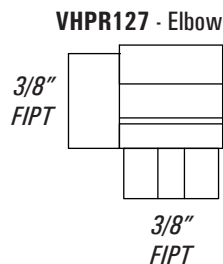
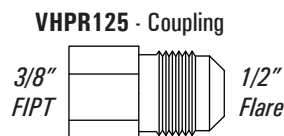
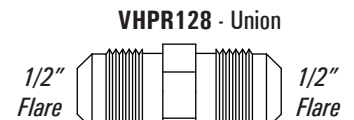
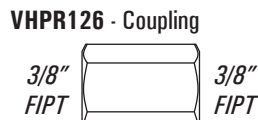
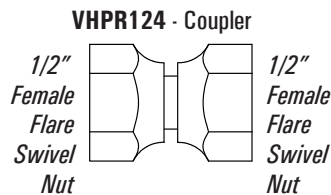
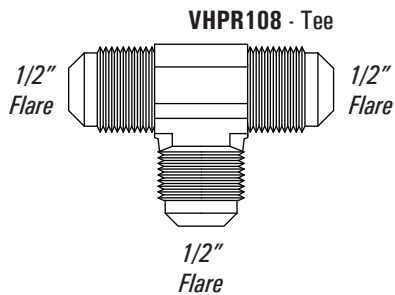

VHPR163 - 2000 psi Ball Valve

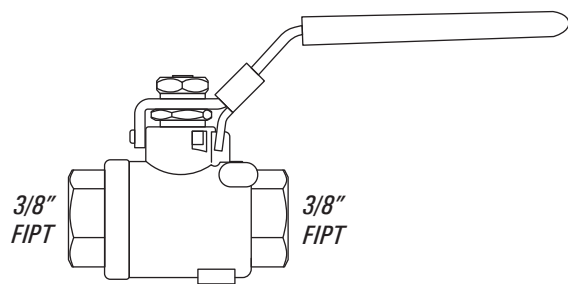

VHPR122 - Tube 3/8" H.P. Nylon



Nozzles

VHPR110 - Nozzle
0.02 GPM
Anti Drip
Nozzle

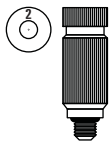

VHPR111 - Nozzle
0.03 GPM
Anti Drip
Nozzle

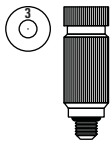

VHPR106 - Nozzle
0.05 GPM
Anti Drip
Nozzle

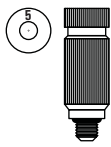

VIEC1000I - Nozzle
Auto Drain
Valve Nozzle

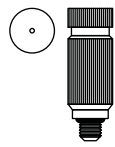

VHPR107 - Nozzle
Nozzle
Plug



VHPR162 - Auto Drain Kit

VHPR120 - O-Ring

7/16" ID x
11/16" OD



VHPR123 - Adapter

3/8" Slip Lock 3/8" MIPT

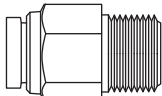

VHPR125 - Coupling

3/8" FIPT 1/2" Flare

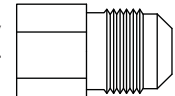

VIEC1000C - Tee

3/8" Slip Lock 3/8" Slip Lock

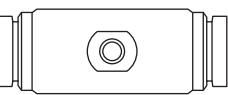

Nozzle
Port

VIEC1000G - Plug

Plug 3/8" Slip Lock

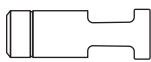

VIEC1000I - Nozzle

Auto Drain
Valve Nozzle



VHPR2002 Series - 20' Long SS Lines with 0.02 GPM Nozzles

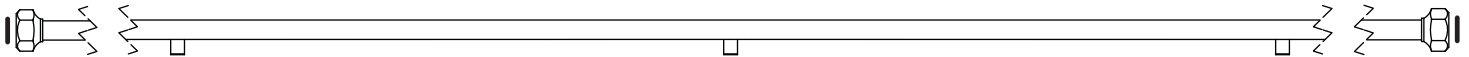

VHPR110 - Nozzle
0.02 GPM
Anti Drip
Nozzle

NOTE: Spacing and quantity of nozzles is dependent on model purchased.

VHPR2003 Series - 20' Long SS Lines with 0.03 GPM Nozzles



VHPR111 - Nozzle
0.03 GPM
Anti Drip
Nozzle

NOTE: Spacing and quantity of nozzles is dependent on model purchased.

VHPR2000 - 20' Long SS Line (No Nozzles or Nozzle Ports)

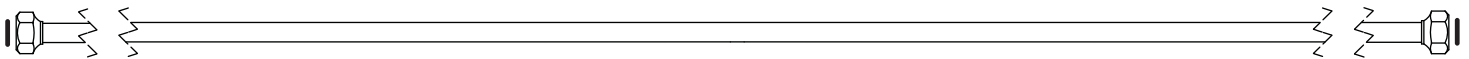

Pipe / Tube Mounting

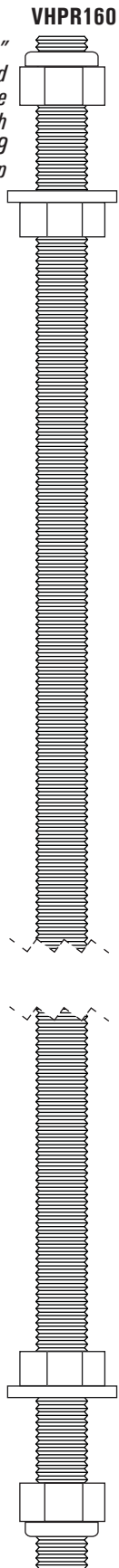
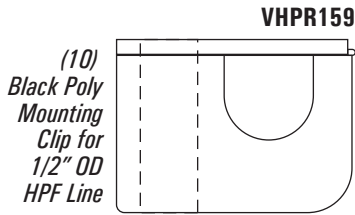
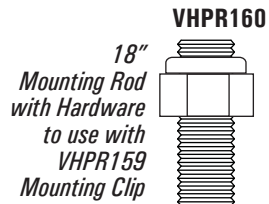
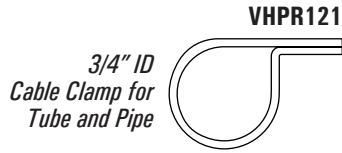

SS3012 - 30" High Pressure Fog Ring Kit with X-Frame

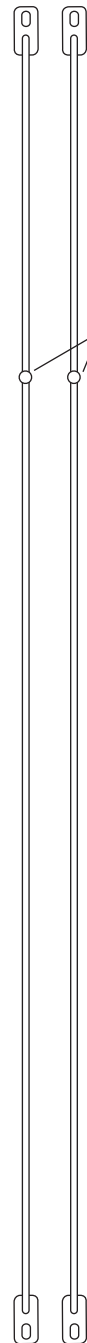
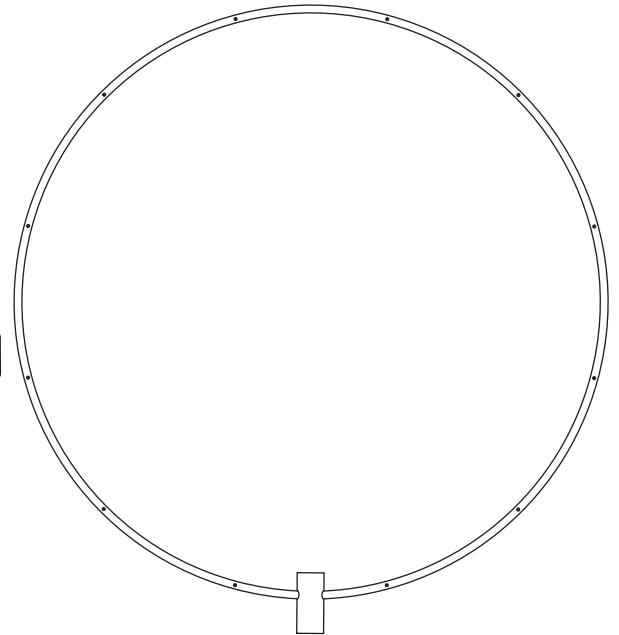

Hanging Pegs

SS3012
30" Stainless steel
panel fan ring kit
with hose connector
and (12) 0.02 GPM
Nozzles

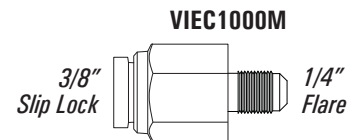
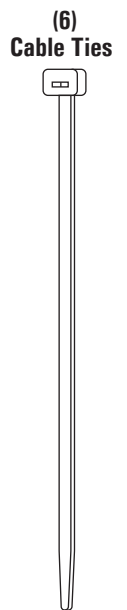
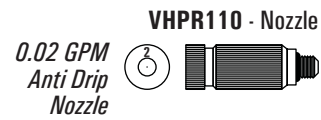

SS3011 - 30" High Pressure Fog Ring Kit

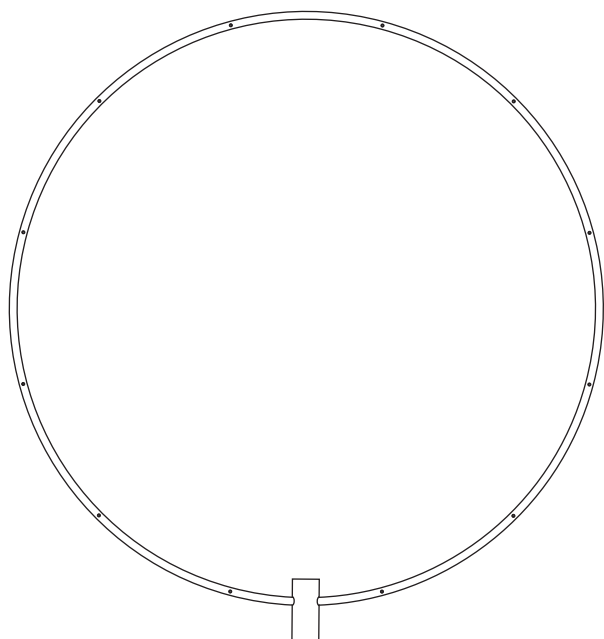

SS3011
30" Stainless steel panel fan ring kit with hose connector and (12) 0.02 GPM Nozzles

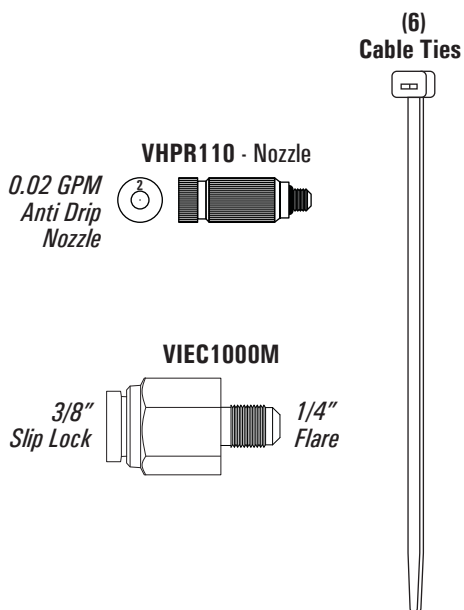

SS36SH6 - 13" 6 Way High Pressure Fog Cross

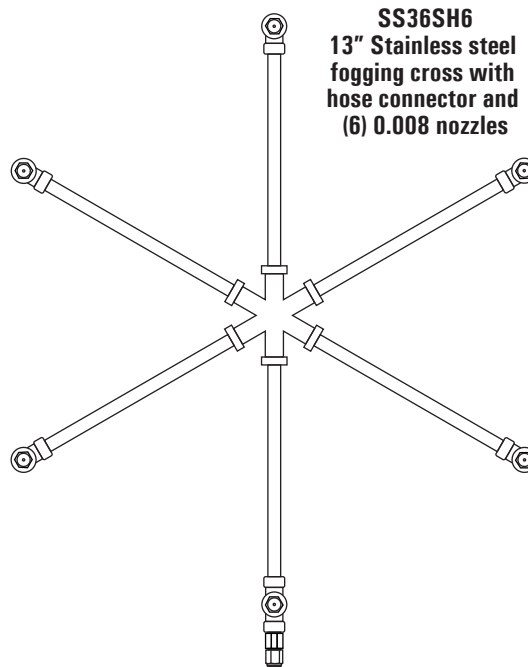

SS36SH6
13" Stainless steel fogging cross with hose connector and (6) 0.008 nozzles

(6)
Cable Ties

SS36SH - 13" 4 Way High Pressure Fog Cross

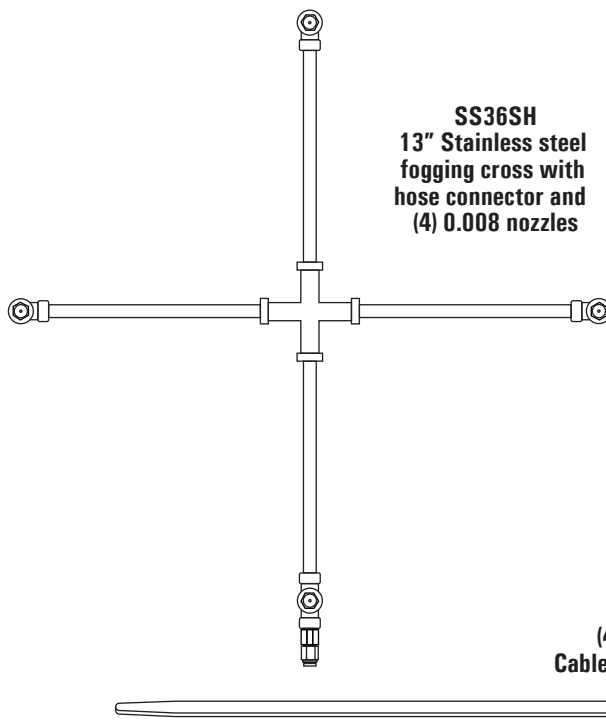

SS36SH
13" Stainless steel fogging cross with hose connector and (4) 0.008 nozzles

(4)
Cable Ties

PVC Gluing Guidelines

Wipe primer around the pipe end and into the fitting to prepare it for the glue/cement. Let it dry about 10 seconds. Spread an even layer of glue/cement on the same surfaces. To keep excess glue/cement from being pushed into water piping, don't apply too much to the inside of the socket on the fitting. At this point you have to work fast to complete the assembly. Align the fitting and pipe about a quarter turn from their final orientation. Then twist the fitting a quarter turn as you press it onto the pipe. Twisting the fitting helps spread the glue/cement evenly to ensure a solid joint. Hold the pipe and fitting together for about 30 seconds until the cement grabs. If you let go too soon, the pipe may push out of the fitting, resulting in a weak joint.

NOTE: PVC primer and PVC glue/cement are not included. When purchasing make sure both are for use with PVC. Read the PVC primer and PVC glue/cement manufacturer's directions and warnings before using and apply all safety recommendations.

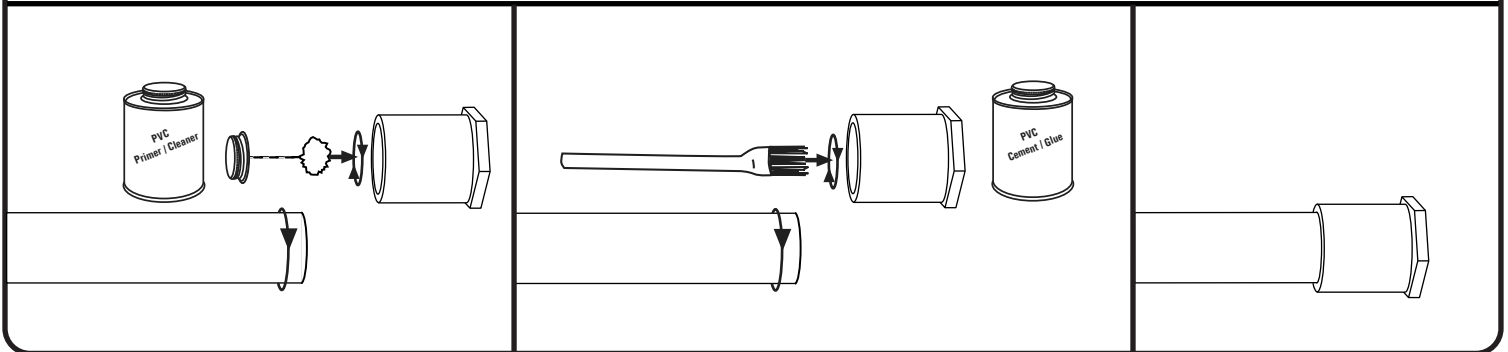

PTFE Tape & Tightening Guidelines

Hold the fitting and starting at the inner end of the threads, wrap PTFE tape tightly and evenly clockwise and upwards in a helical fashion until all but the end thread is covered. *Leaving the end thread bare makes it easier to get the thread started during assembling of joints.* Continue to wind the thread clockwise and downwards back to where you started then once more towards end of fitting. This method will provide industry standard of three layers of PTFE tape.

Screw the male thread into the female union by hand until tight, then using a wrench rotate the fitting an additional 1-2 turns, **DO NOT OVER TIGHTEN.**

NOTE: Some fittings may come with a layer of dried white PTFE sealant that was previously applied to the threads by the manufacturer of the connector. **DO NOT** add additional PTFE tape to these fittings; just assemble as is.

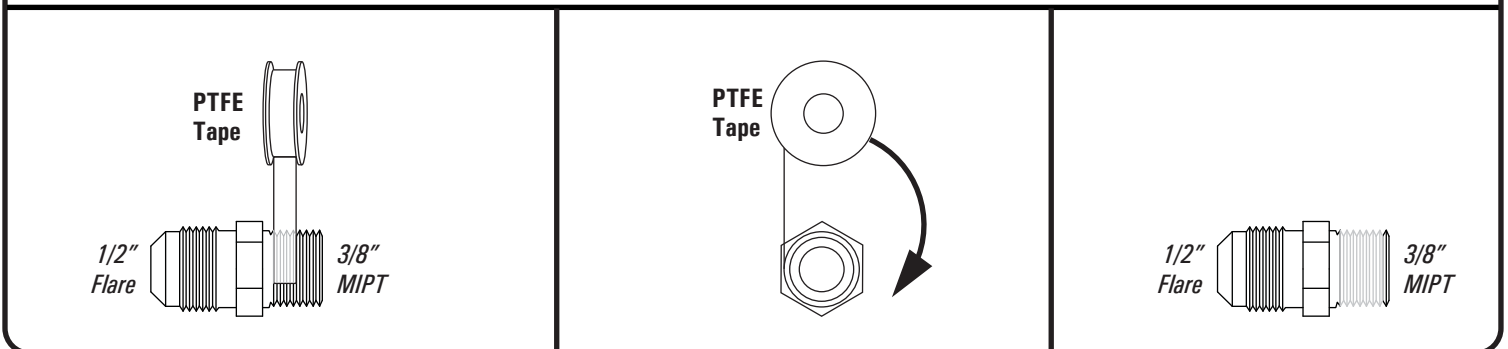

1/2" Flare Connector with Required O-Ring Guidelines

1/2" flare connector ends require an o-ring to complete the union. Insert the o-ring into the union and position it so it does not block the waterway. With o-ring in place screw the male thread into the female union by hand until tight; using a wrench rotate the fitting an additional 1/2 to 1 turn. **DO NOT OVER TIGHTEN.**

NOTE: Stainless steel line ends have a 1/2" flare nut on each end and include the required o-rings needed for this connection. The purchase of additional o-rings (VHPR120) is only required for replacement if needed or when the 1/2" male flare connector is used with other 1/2" female flare connectors.

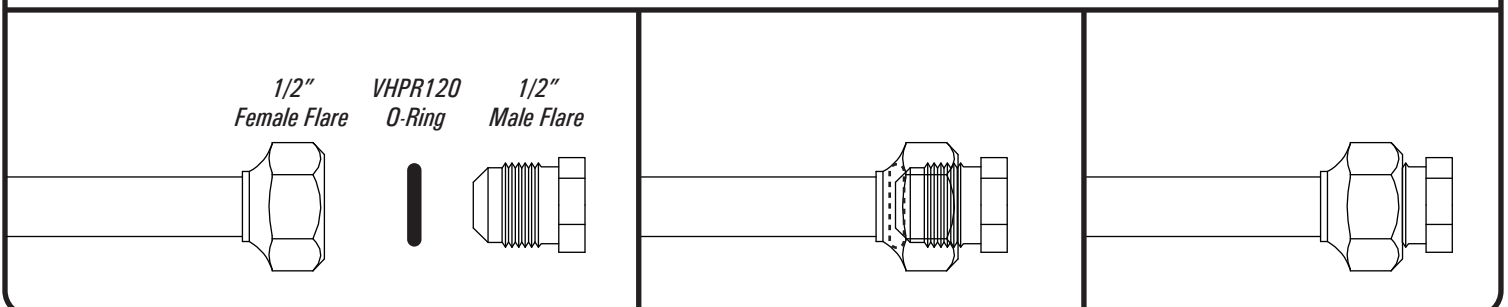

Slip Lock Guidelines

Slip lock connectors requires the nylon tube be cut straight, cleanly, and without crimping or deforming the tube while cutting.

If the other end of the fitting is not a slip lock, connect that first.

Insert the end of the nylon tube into the slip lock until you meet some resistance then push it in another 1/2" or so until it stops.

If you need to remove the nylon tube from the slip lock, the system must be depressurized. Then push the metal slip lock collar back into the fitting and pull the nylon tube out.

NOTE: Once the nylon tube has been fully inserted into a slip lock and is removed, even for a short time, 1" of nylon tube (the amount that was inserted into the slip lock) must be trimmed off or it will not seal properly. Keep this in mind if you intend to disassemble your system seasonally as you will want to provide additional tubing to those sections to allow for yearly trimming until you are required to replace your nylon tubing.

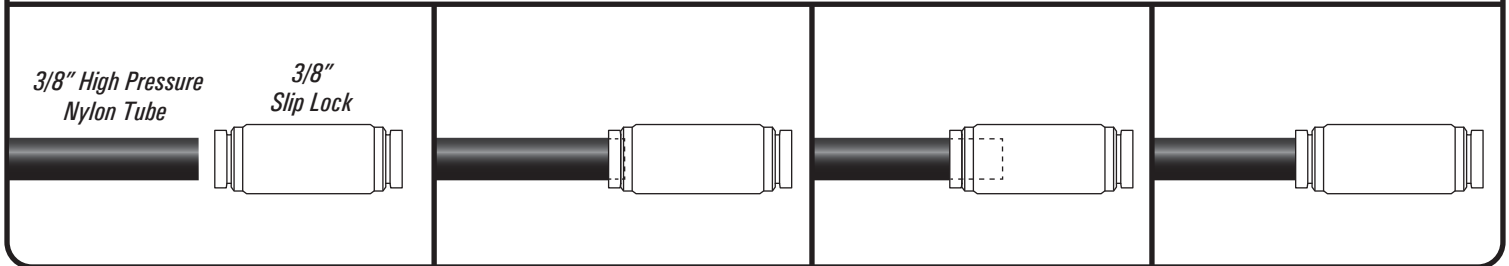

High Pressure Nylon Tube Guidelines

When system is running the high pressure nylon tube will vibrate and jump causing nearby sharp or abrasive surfaces to cut or wear a hole in the nylon tube.

Rubber grommets, pieces of rubber mats, etc., should be used to protect the tube.

3/8" High Pressure Nylon Tube



Preparing 1" PVC Tubing 2' Stick (VHPR151) for Assembly

Measure and mark the tube into (6) 4" sections.

Using the marks just made and a fine toothed saw cut tubing into sections.

Clean and deburr each end of cut tube.

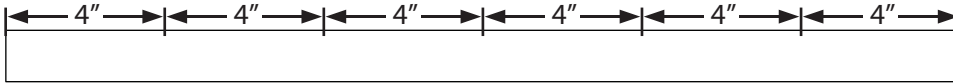

1



Before Filter Tee Assembly

Following the PVC Gluing Guidelines in **Section E**, prime and glue a section of 4" tube, tee (SS0T), and another section of 4" tube as shown below.

2

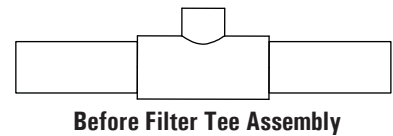
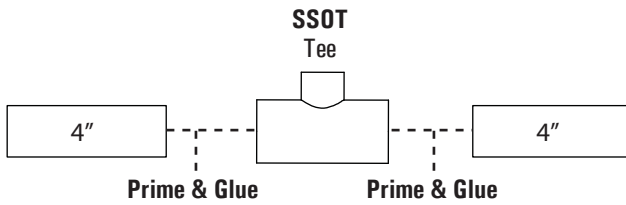

After Filter Tee Assembly

Following the PVC Gluing Guidelines in **Section E**, prime and glue a section of 4" tube, tee (SS0T), and reducer bushing (VHPR146) as shown below.

3

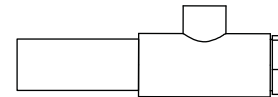
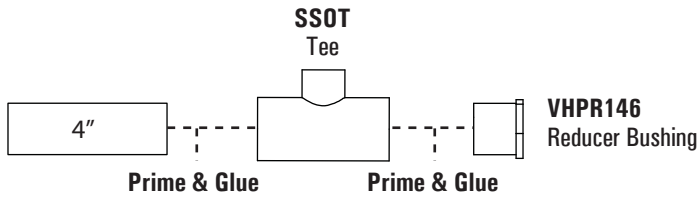

Check and Ball Valve Assembly

Following the PVC Gluing Guidelines in **Section E**, prime and glue check valve (SS03), a section of 4" tube, and ball valve (SS01) as shown below.

4

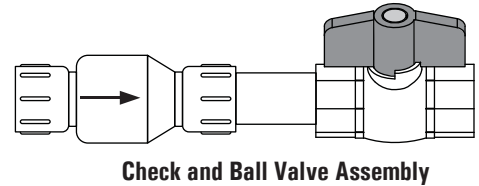
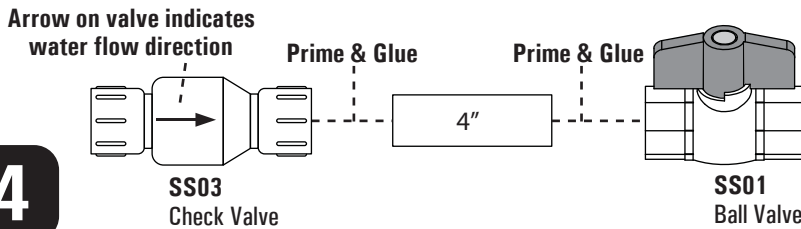

Pressure Gauge Assembly

Following the PTFE Tape & Tightening Guidelines in **Section E**, tape and assemble both pressure gauges (VHPR149) to a reducer (SS19) as shown below.

5

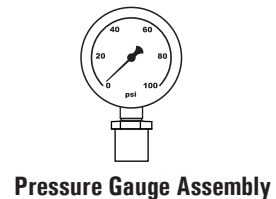
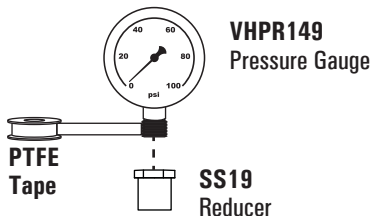

If your filter system uses 4-1/2" filter housings, proceed to **Step 8**.

2-1/2" Filter Cap Assembly

Remove the caps from each of the filter housings (VHPR135).

Following the PTFE Tape & Tightening Guidelines in **Section E**, tape and assemble two threaded adapters (PP10461) to each filter housing cap as shown below.

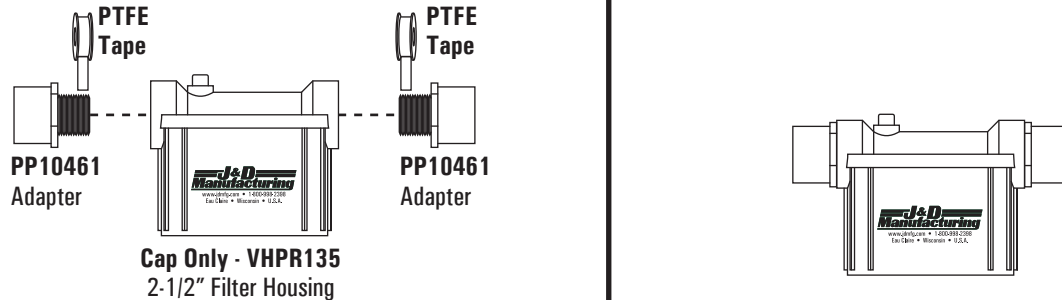

Set all three caps on a flat surface and arrange caps so IN and OUT are as shown below.

Following the PVC Gluing Guidelines in **Section E**, prime and glue a section of 4" tube between each cap as shown below.

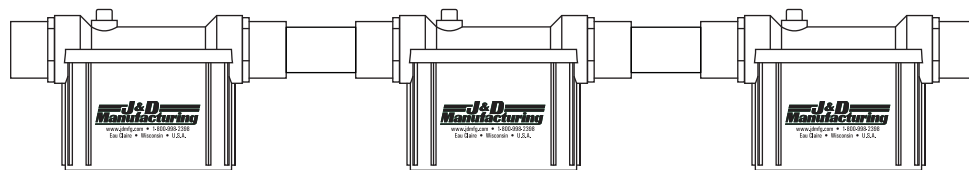
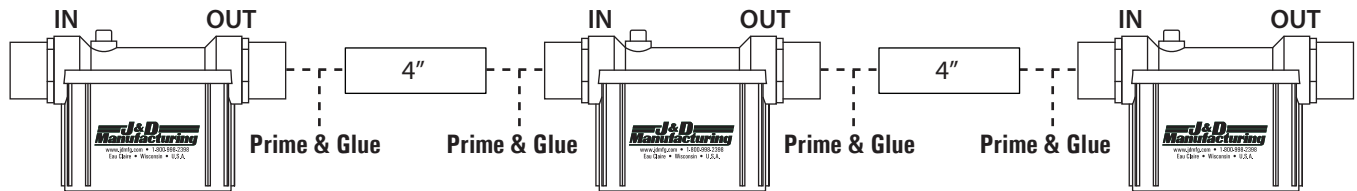

2-1/2" Filter Cap Assembly

6

Attaching Brackets to 2-1/2" Filter Cap Assembly

Using either a #3 phillips head hand driven screwdriver or a #3 phillips head drill bit and drill with its clutch/torque adjusted to not strip the holes, secure the three filter mounting brackets (VHPR142) to the filter cap assembly using (4) #14-10 x 3/4" phillips pan head screws per bracket as shown below.

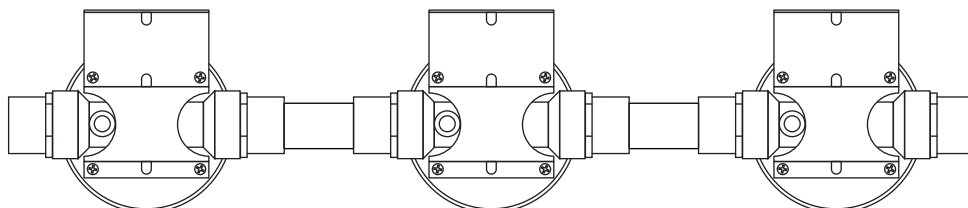
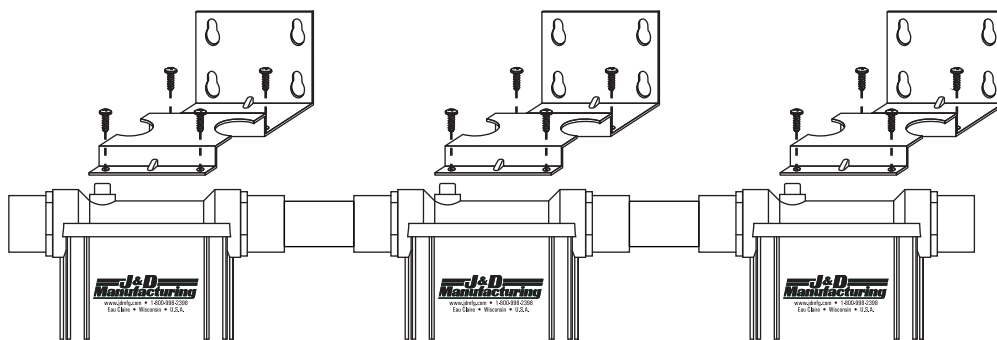

7

If your filter system uses 2-1/2" filter housings, proceed to **Step 10**.

4-1/2" Filter Cap Assembly

Remove the caps from each of the filter housings (VHPR139).

Following the PTFE Tape & Tightening Guidelines in **Section E**, tape and assemble two threaded adapters (VHPR143) to each filter housing cap as shown below.

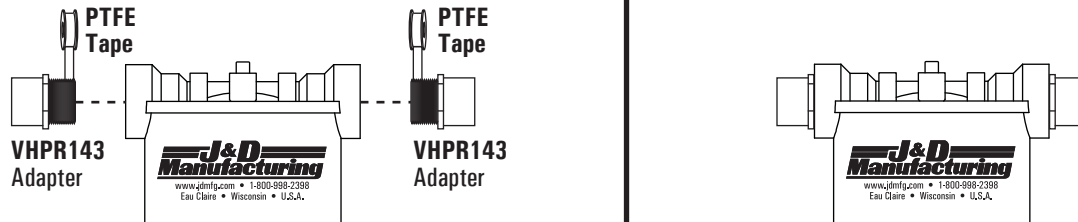

Set all three caps on a flat surface and arrange caps so IN and OUT are as shown below.

Following the PVC Gluing Guidelines in **Section E**, prime and glue a section of 4" tube between each cap as shown below.

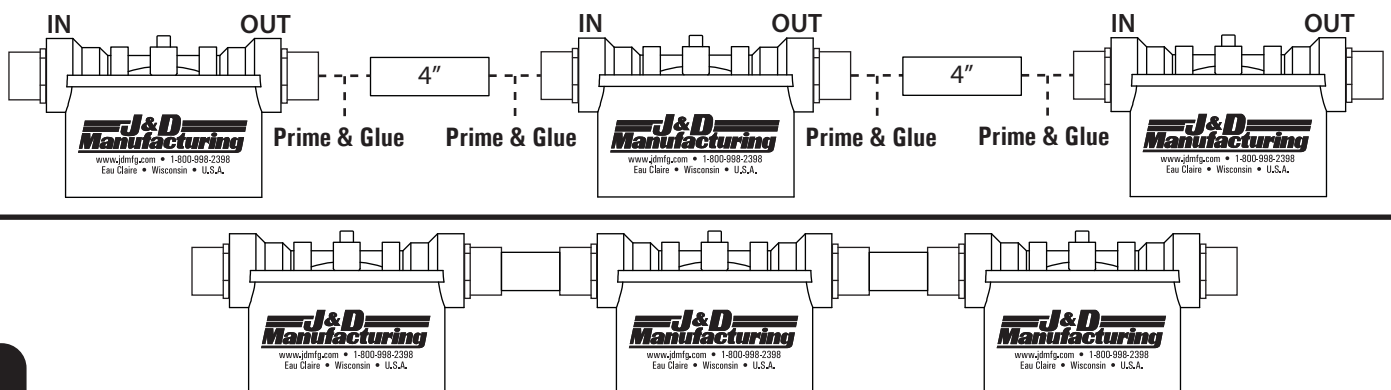

4-1/2" Filter Cap Assembly

8

Attaching Brackets to 4-1/2" Filter Cap Assembly

Using either a #3 phillips head hand driven screwdriver or a #3 phillips head drill bit and drill with its clutch/torque adjusted to not strip the holes, secure the three filter mounting brackets (VHPR153) to the filter cap assembly using (4) #14-10 x 3/4" phillips pan head screws per bracket as shown below.

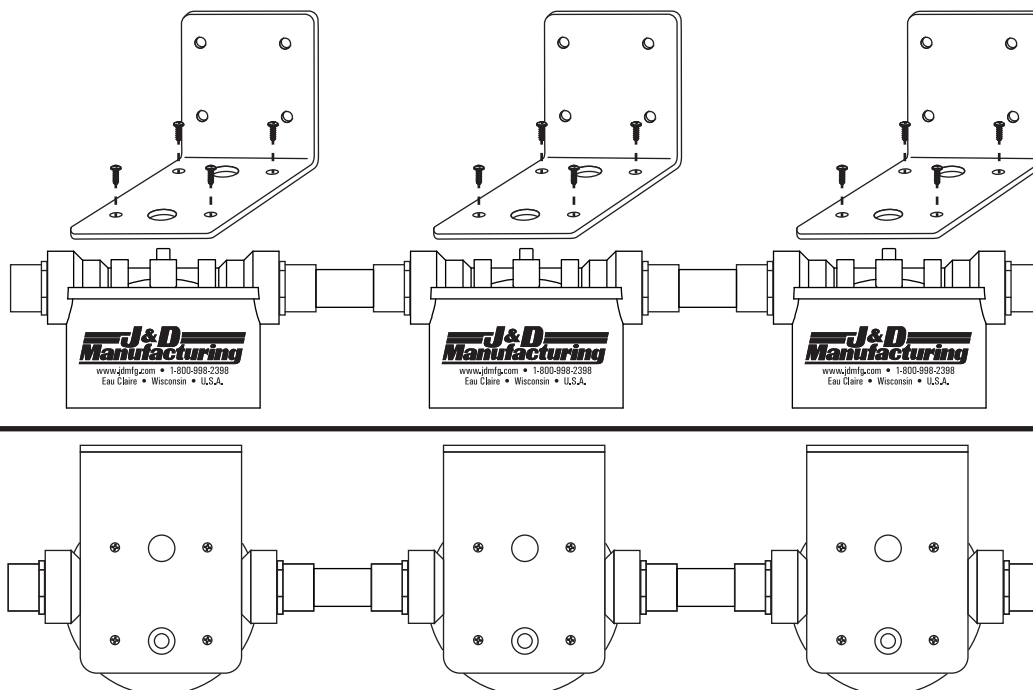

9

From this point in the instructions only the 4-1/2" filter assembly will be shown in the illustrations however the same steps must be applied to the 2-1/2" filter system as the remaining instructions are the same.

Mounting Filter Cap Assembly

To provide the space needed to access and service the filters once system is installed, measure and mark 37" from the floor as shown below. Align the top of the filter mounting plates to this mark and prepare the (4) locations per bracket indicated below for the installation hardware (not included). Secure the mounting plate to your chosen location.

NOTE: Mounting location and installation hardware (not included) must be able to withstand the weight of 90lbs, the assembled unit when in use and full of water.

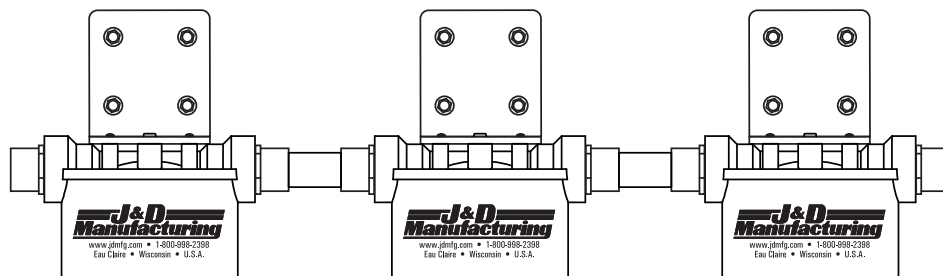
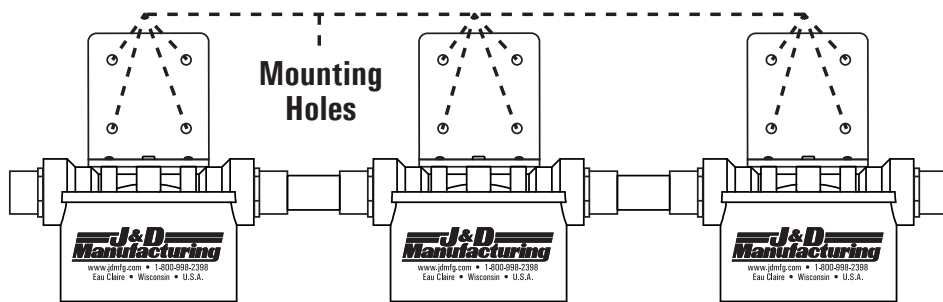
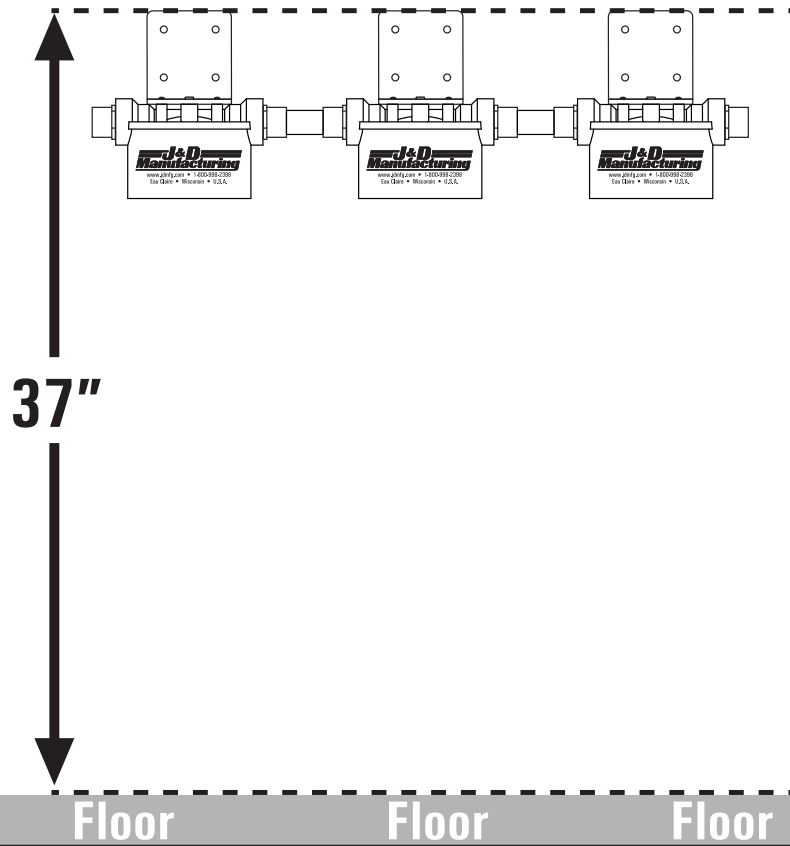

10

Assembling Tees to Mounted Filter Assembly

Following the PVC Gluing Guidelines in **Section E**, prime and glue the **Before Filter Tee Assembly** from **Step 2** to the IN side of the **Filter Cap Assembly** and the **After Filter Tee Assembly** from **Step 3** to the OUT side of the **Filter Cap Assembly** as shown below.

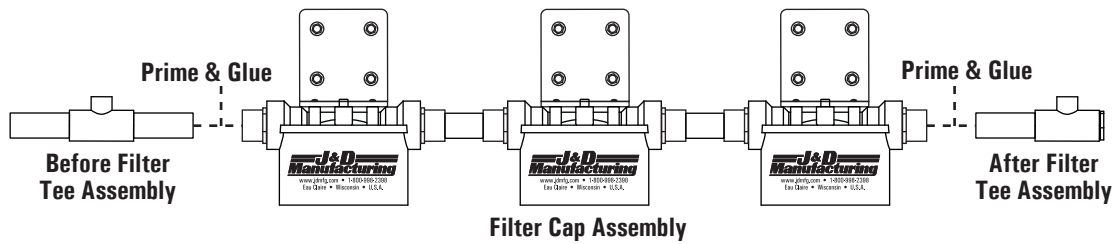

11

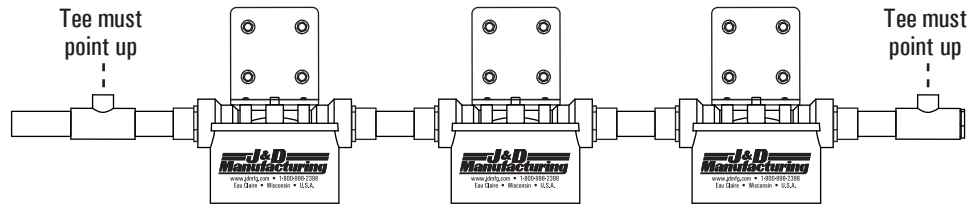

Assembling Gauges to Tees

Following the PVC Gluing Guidelines in **Section E**, prime and glue one of the **Pressure Gauge Assemblies** from **Step 5** to the **Before Filter Tee Assembly** and the other **Pressure Gauge Assembly** from **Step 5** to the **After Filter Tee Assembly** as shown below.

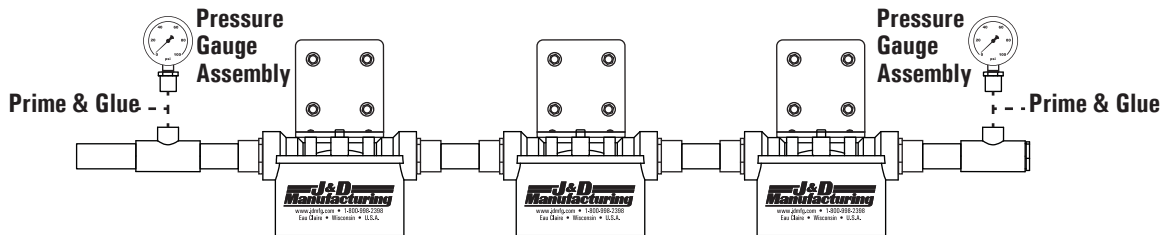

12

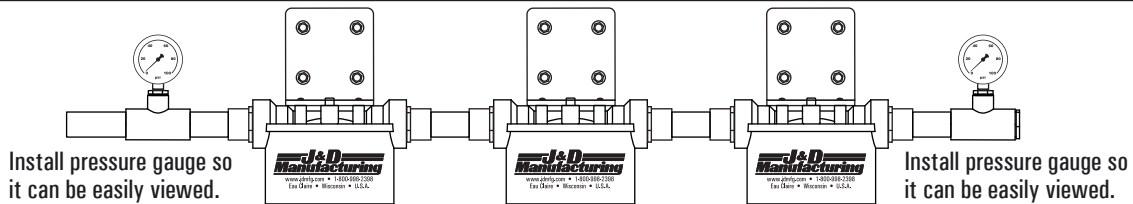

Assembling Check & Ball Valve to Mounted Filter Assembly

Following the PVC Gluing Guidelines in **Section E**, prime and glue the **Check & Ball Valve Assembly** from **Step 4** to the **Before Filter Tee Assembly** as shown below.

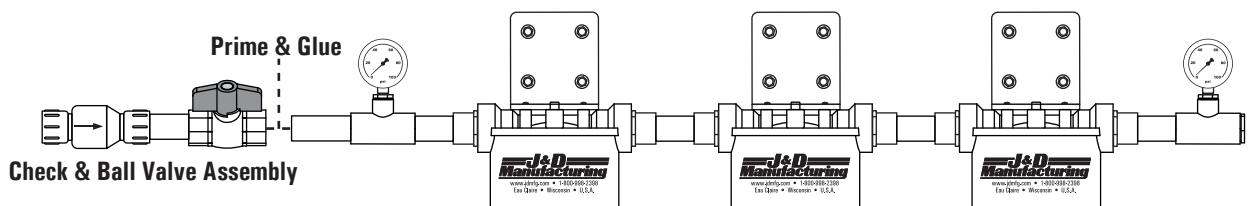

13

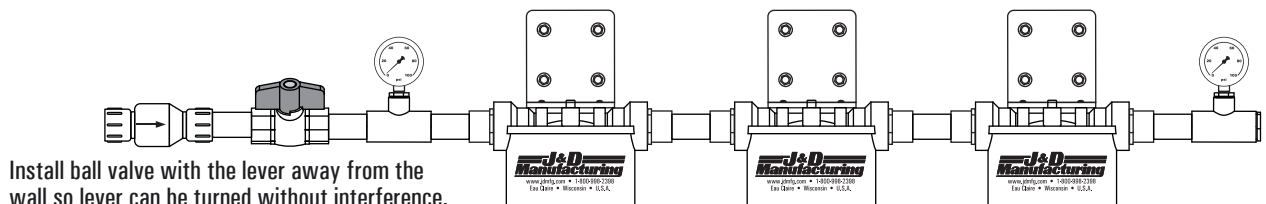

Assembling Adapter to Mounted Filter Assembly

Following the PTFE Tape & Tightening Guidelines in **Section E**, tape and assemble male adapter (VHPR147) to **Before Filter Tee Assembly** as shown below.

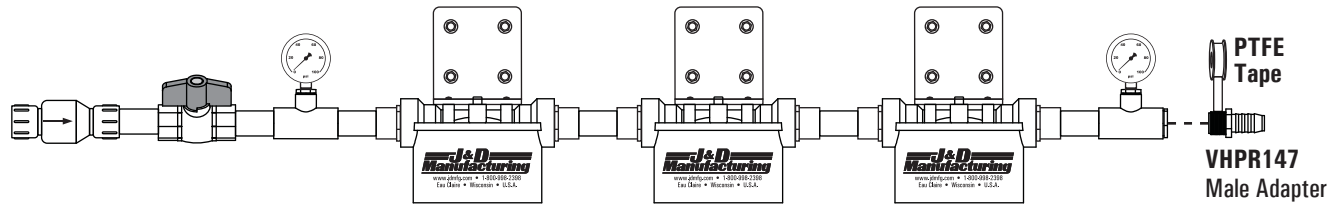

14

Attaching Labels to Bracket of Mounted Filter Assembly

Attach the labels that indicate filtration size to the mounting brackets as shown below, this will aid in filter maintenance and replacement in the future.

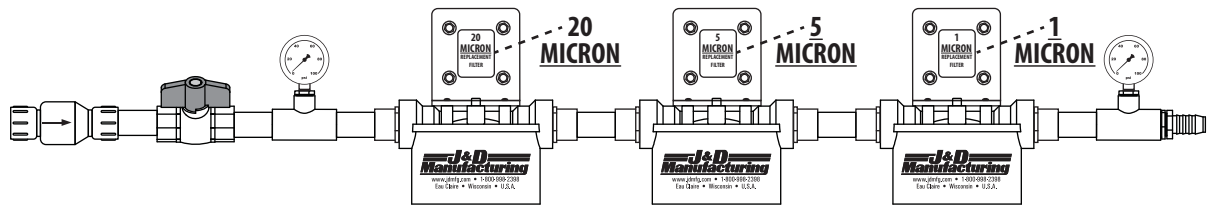

15

Connecting Water Source to Mounted Filter Assembly

With water shut off and following the PVC Gluing Guidelines in **Section E**, connect the water source to the check valve.

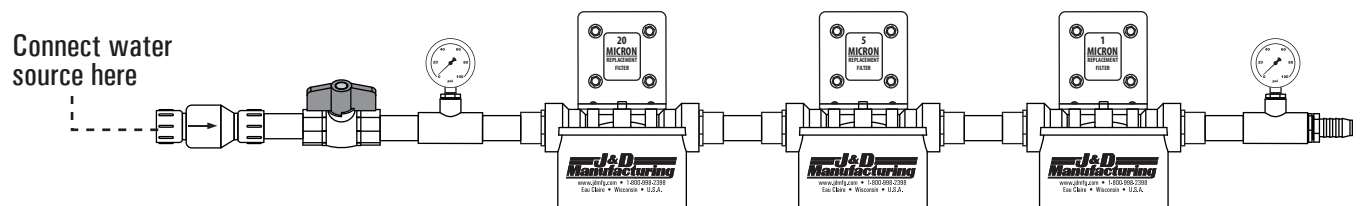

16

If your structure has studs 24" on center, proceed to Step 4.

Mounting Shelf Assembly to Structure that has Studs 16" On Center

Prepare the (8) locations indicated below for the installation hardware (not included) and secure the mounting shelf to your chosen location as shown below.

NOTE: Mounting location and installation hardware (not included) must be able to withstand the weight of 145 lbs, the assembled shelf with motor and pump assembly.

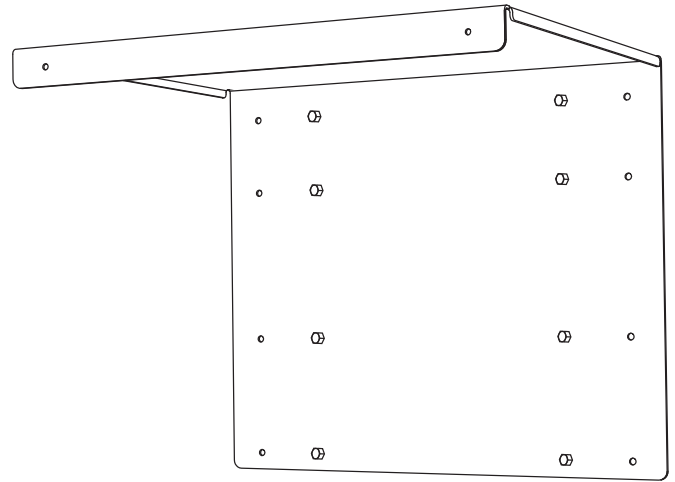
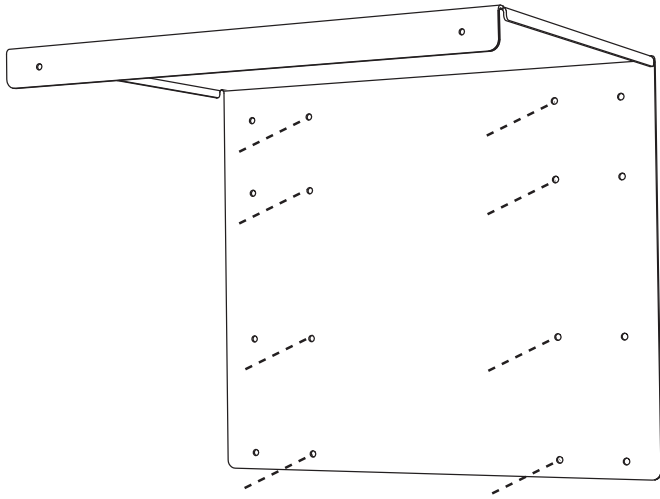

1

Assemble Shelf Support Brackets

Using a 9/16" wrench and 9/16" socket and socket wrench assemble (2) shelf braces so the mounting tabs are behind the shelf lip and secure with (2) 3/8" - 16 x 1" Hex Bolts and (2) 3/8" - 16 Nylock Nuts as shown below.

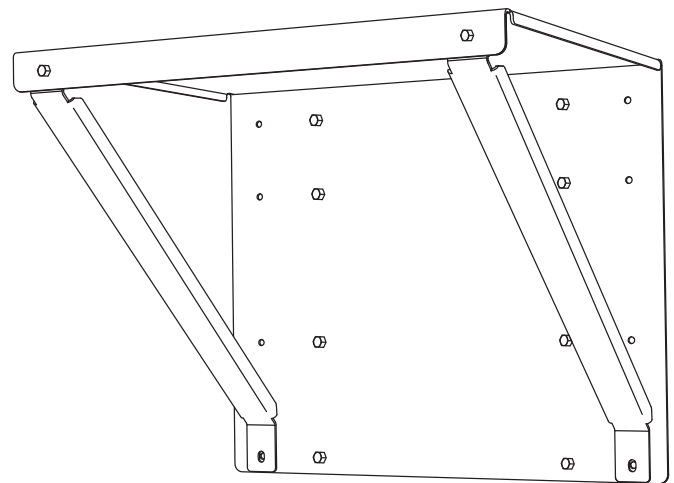
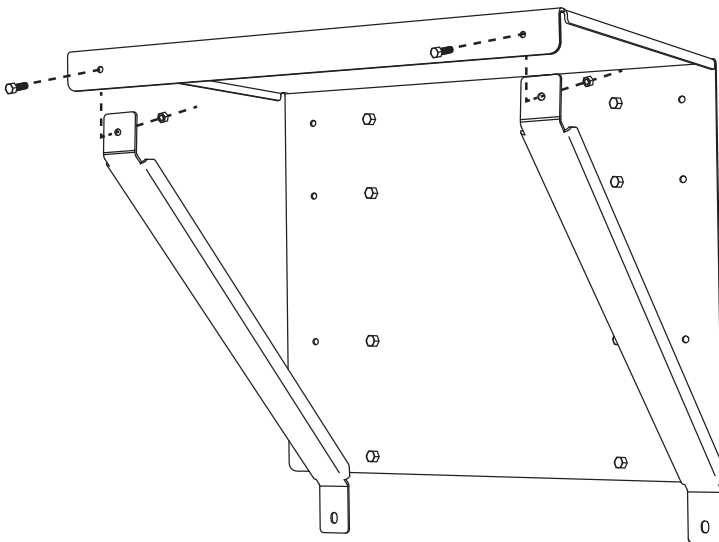

2

Secure Shelf Support Brackets to Mounting Shelf and Structure

Prepare the (2) locations indicated below for the installation hardware (not included) and secure the shelf support bracket to the mounting shelf and structure as shown below.

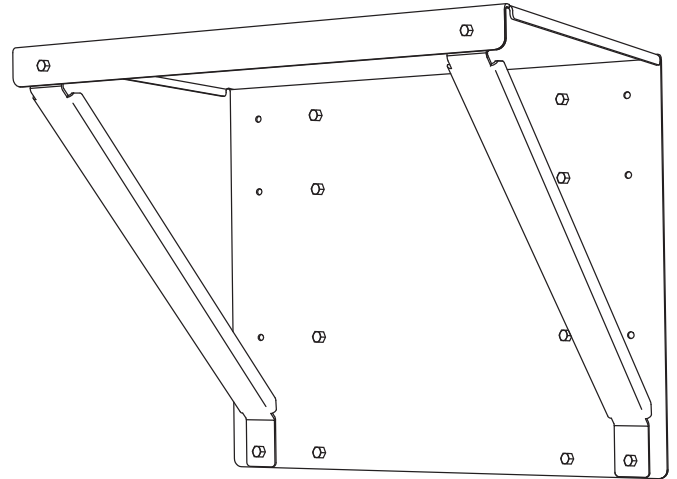
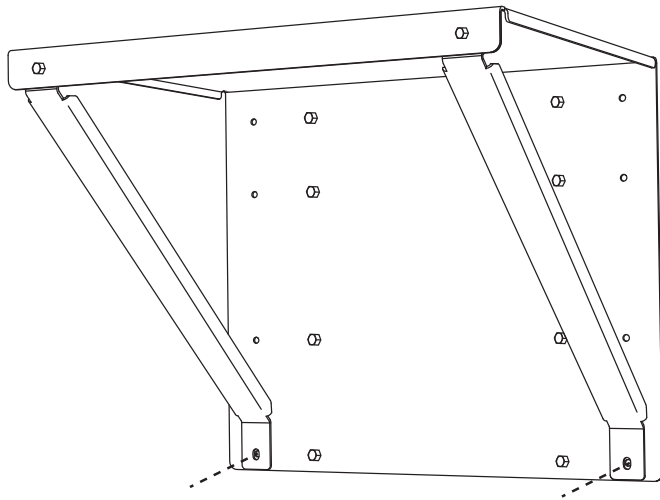
**3****Proceed to Step 7.****Mounting Shelf Assembly to Structure that has Studs 24" On Center**

Prepare the (6) locations indicated below for the installation hardware (not included) and secure the shelf assembly and bottom of support brackets to your chosen location as shown below.

NOTE: Mounting location and installation hardware (not included) must be able to withstand the weight of 145 lbs, the assembled shelf with motor and pump assembly.

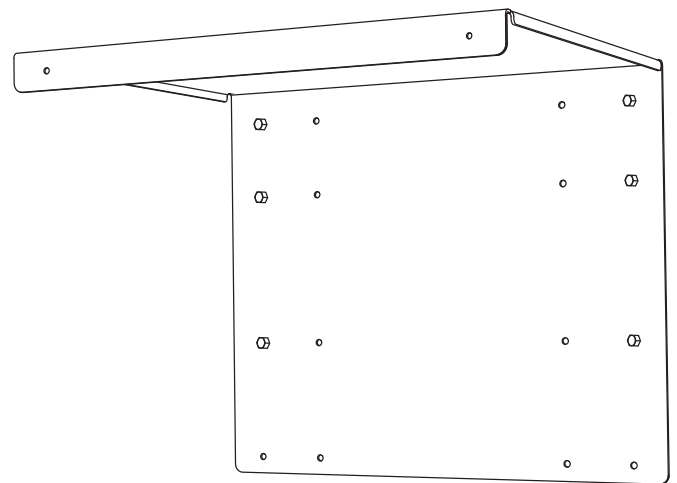
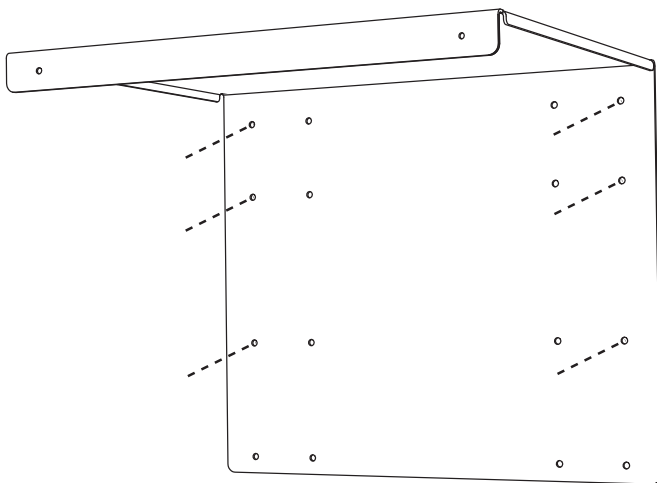
**4**

Assemble Shelf Support Brackets

Using a 9/16" wrench and 9/16" socket and socket wrench assemble (2) shelf braces so the mounting tabs are behind the shelf lip and secure with (2) 3/8"-16 x 1" Hex Bolts and (2) 3/8"-16 Nylock Nuts as shown below.

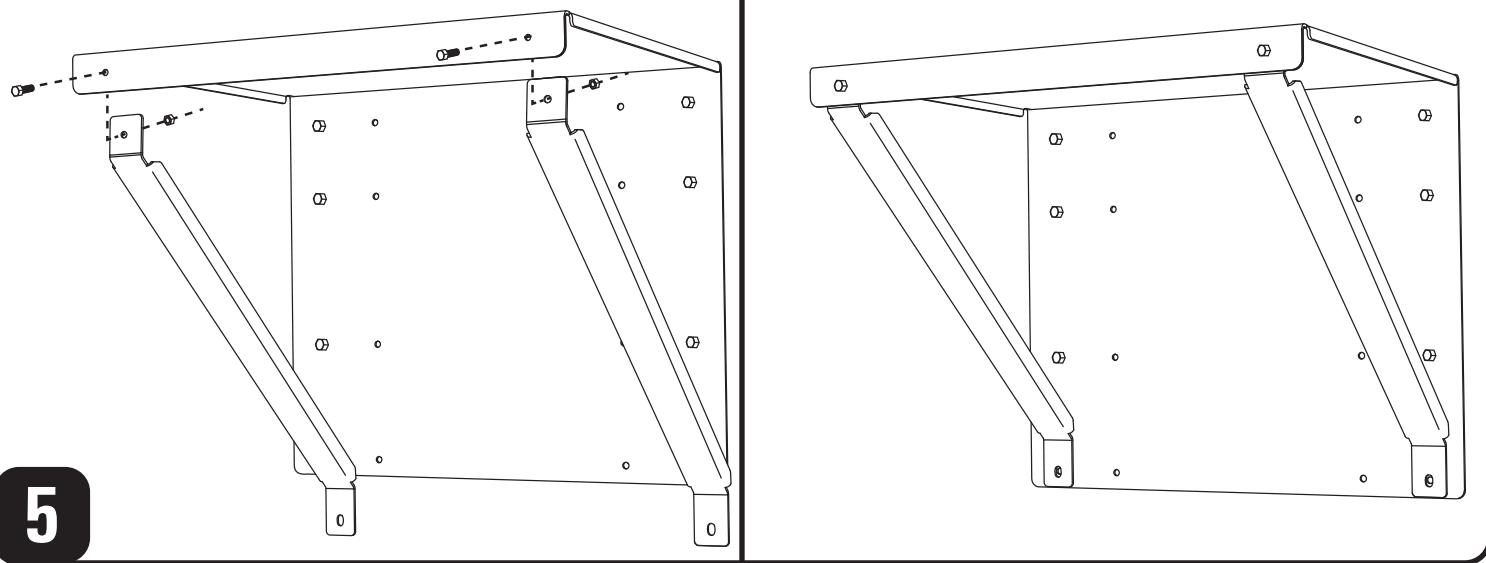
**Secure Shelf Support Brackets to Mounting Shelf and Structure**

Prepare the (2) locations indicated below for the installation hardware (not included) and secure the shelf support bracket to the mounting shelf and structure as shown below.

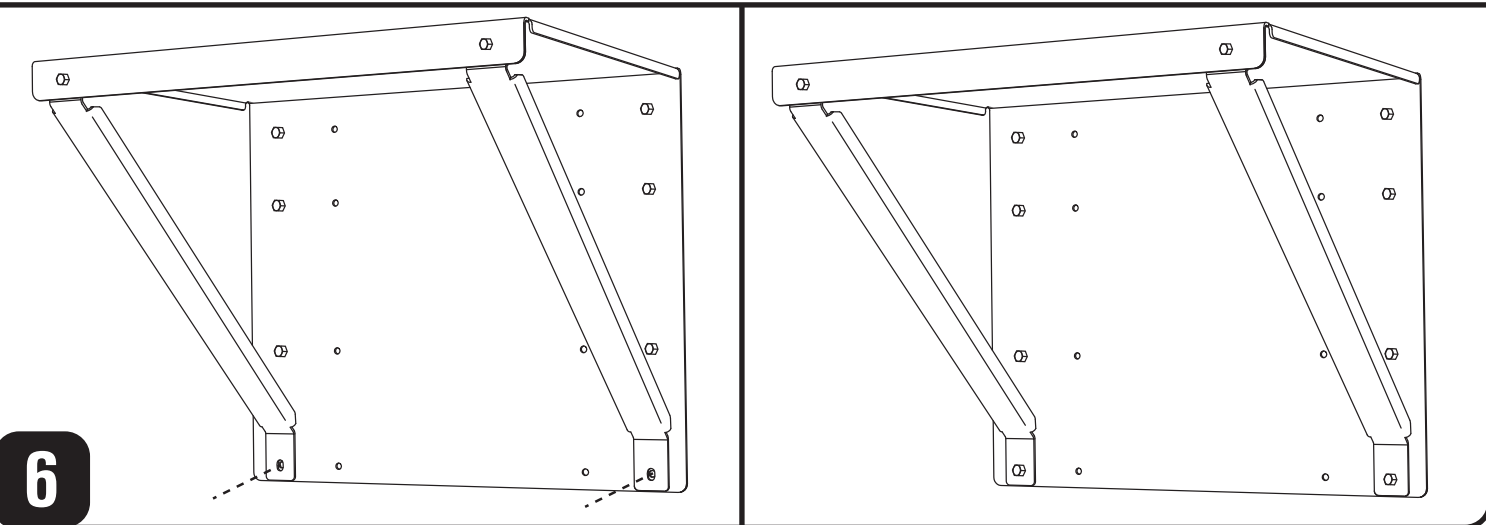
**Applying Labels to Mounting Shelf Assembly**

Clean and dry the (2) locations indicated below and apply the J&D labels as shown below.

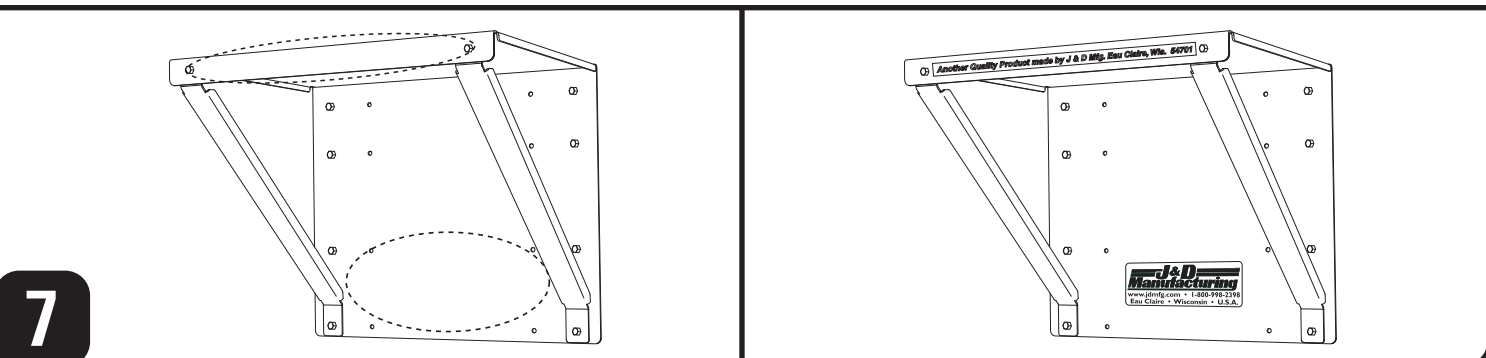

Preparing Pump Motor for Assembly

Apply the contents of the PP10815 anti-seize lubricant packet onto the shaft of the motor as shown.

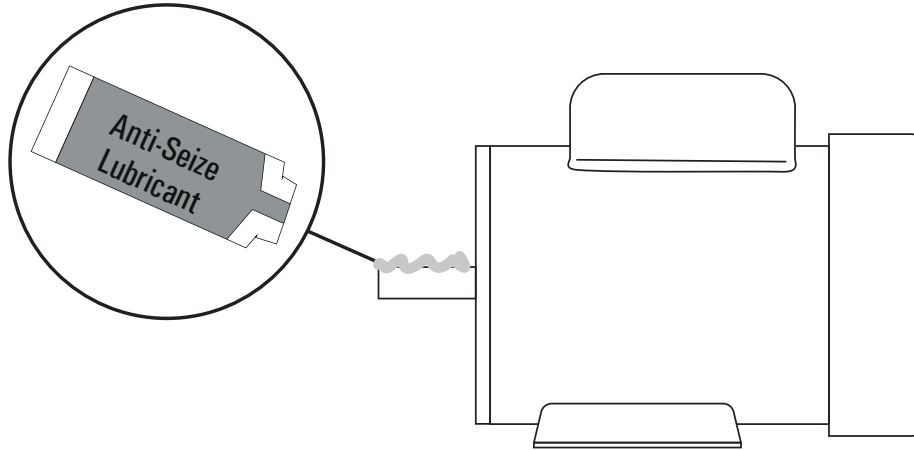

1

If the pump for your system is VHPP41, VHPP57, or VHPP137, proceed to Step 3.

Assembling VHPP13 or VHPP30 Pump to Motor

Using a 9/16" socket and (4) 3/8"-16 x 1" Hex Bolts and (4) 3/8" Split Lock Washers, assemble and secure the pump to the motor as shown below.

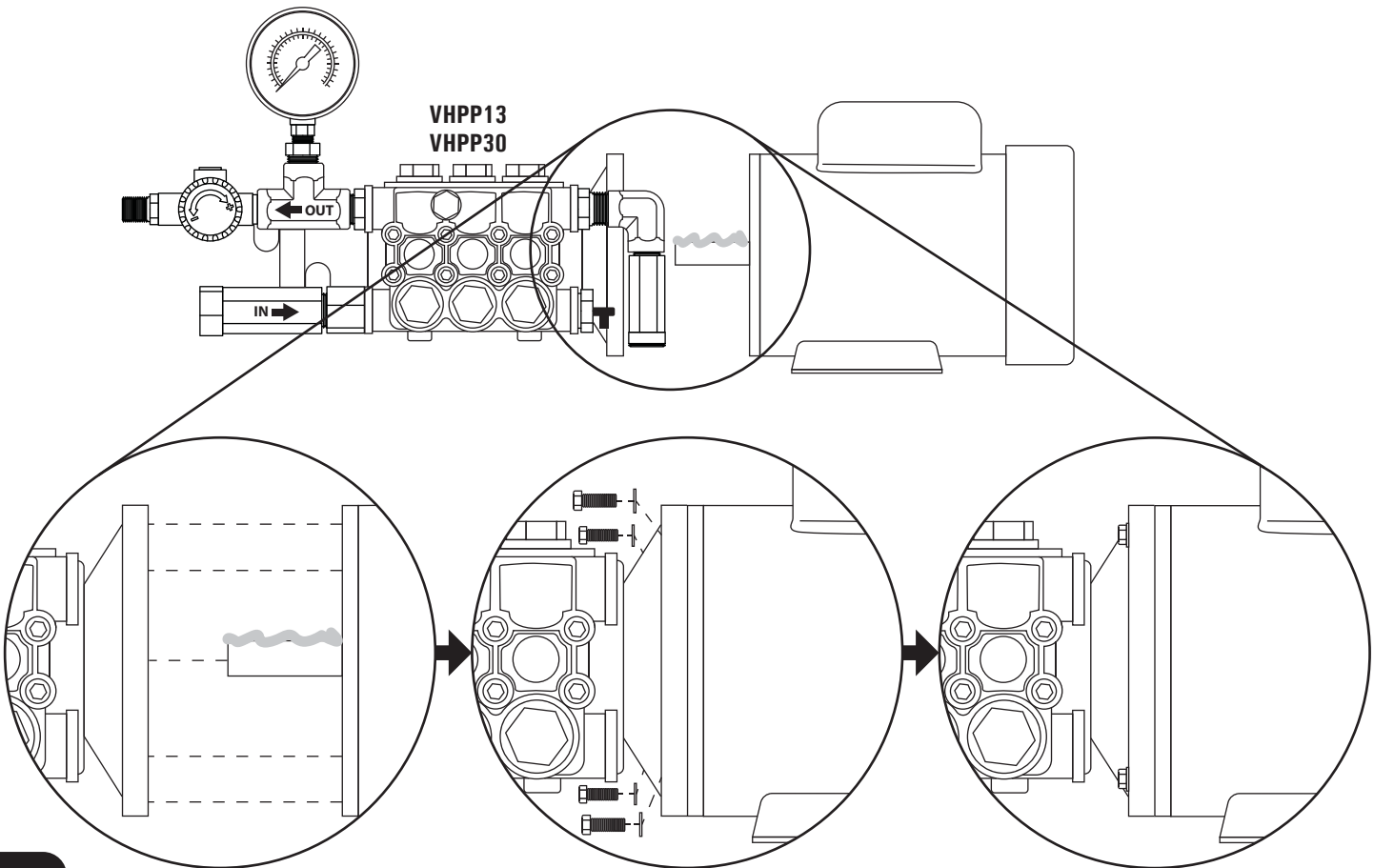

2

If the pump for your system is VHPP13 or VHPP30, proceed to Step 5.

Secure the Flex Coupler to the VHPP41, VHPP57, or VHPP137 Pump Shaft and Motor Shaft

Slide the flex coupler halves as far as they will go onto the pump shaft and motor shaft as shown below. Secure using a 3 MM Hex Key to tighten the set screws. The set screw on the flex coupler half that is inserted into the bell and onto the pump shaft can be accessed using the slit in the top of the bell as indicated below.

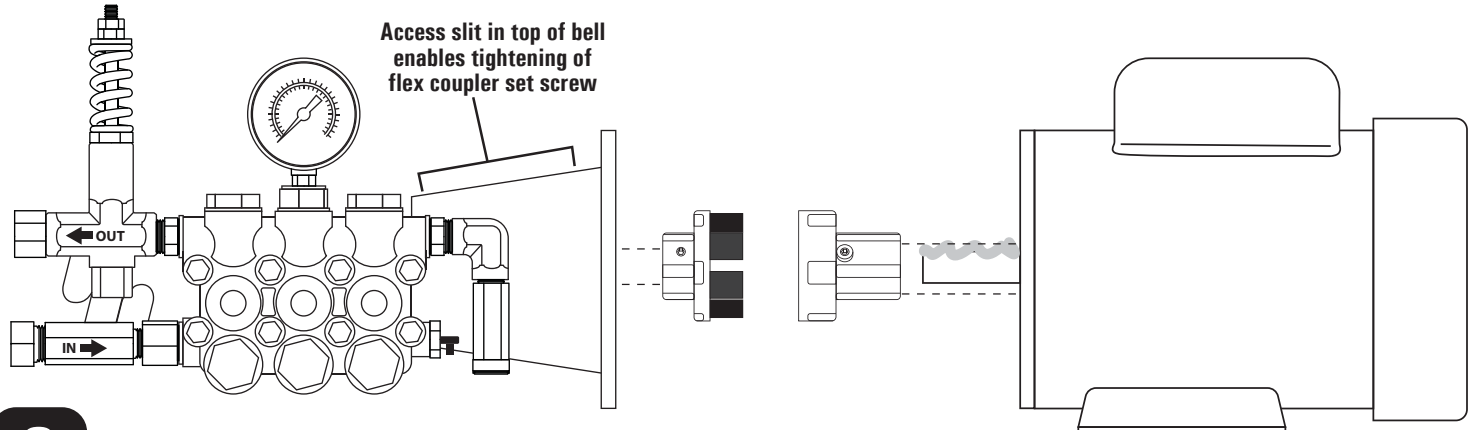
**3****Assembling VHPP41, VHPP57, or VHPP137 Pump to Motor**

Using a 9/16" socket and (4) 3/8"-16 x 1" Hex Bolts and (4) 3/8" Split Lock Washers, assemble and secure the pump to the motor as shown below.

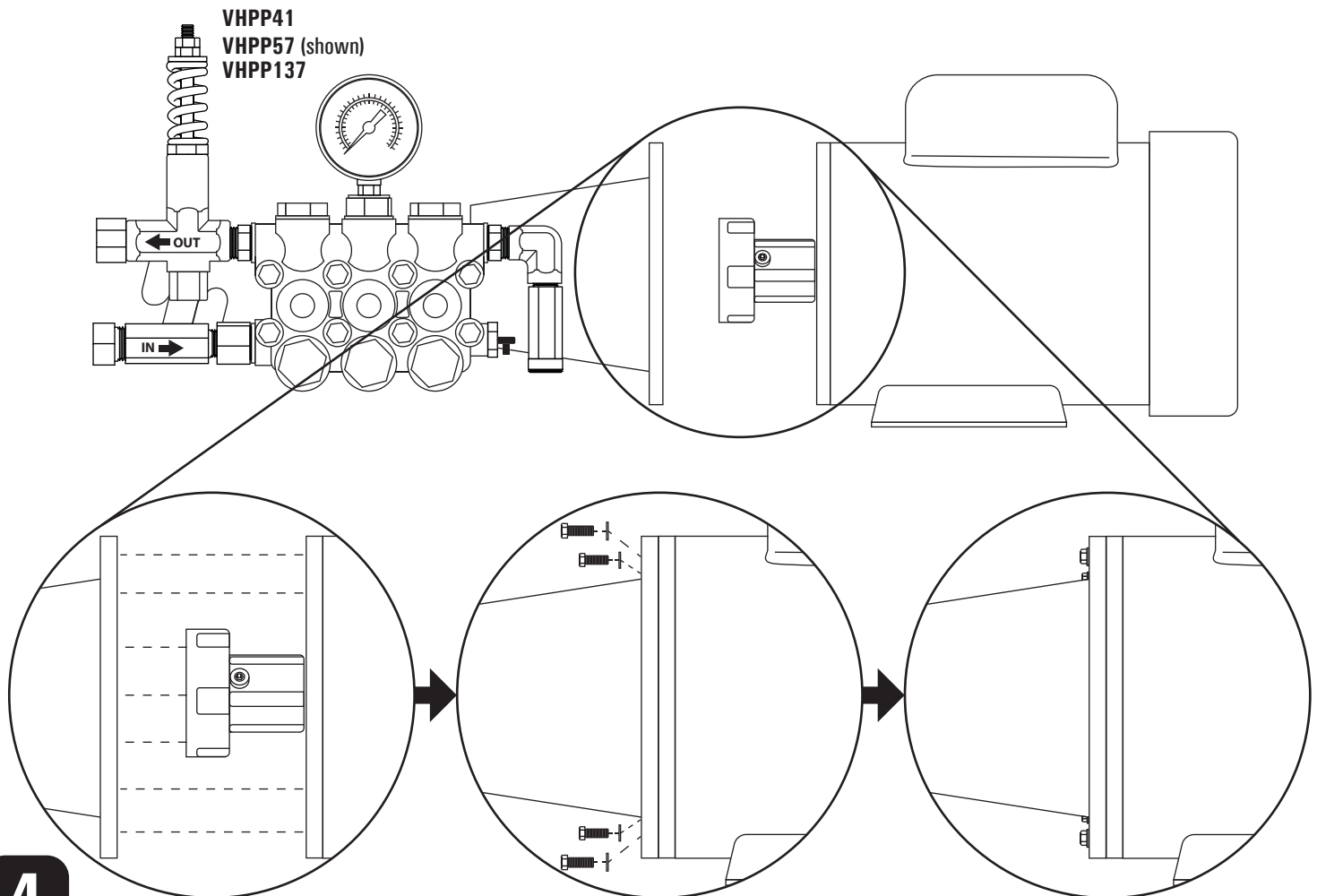
**4**

Installing the Pump Dipstick/Breather Valve

On the top of the pump will be a red cap, remove the red cap, insert dipstick/breather valve, and secure by hand turning until snug.

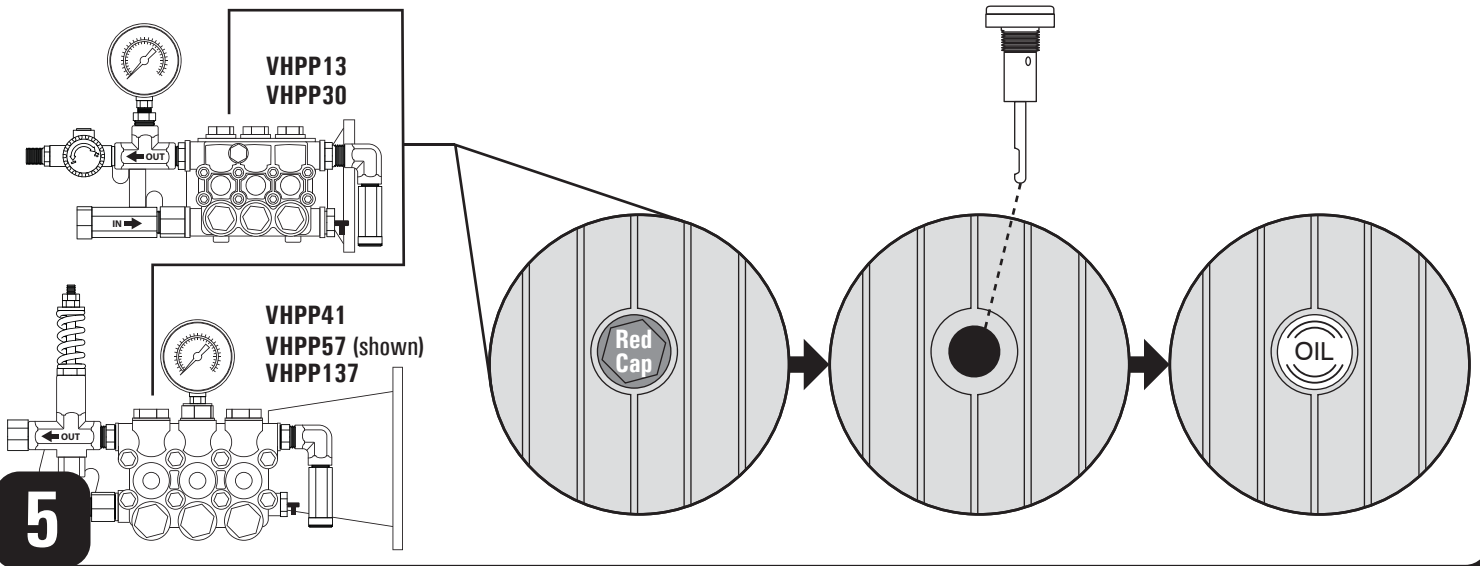
**Attach Motor Pump Assembly to Motor Pump Shelf**

Align the motor foot mount with a matching set of pre-drilled mounting holes in the shelf top. Using one of the below matched tool and hardware combinations that matches your motor foot mount, secure motor pump assembly to shelf top.

- 9/16" wrench and 9/16" socket - (4) 3/8"-16 x 1" Hex Bolts and (4) 3/8" -16 Nylock Nuts
- 1/2" socket - (4) 5/16"-18x3/4" Carriage Bolts and (4) 5/16"-18 Nylock Flange Nut

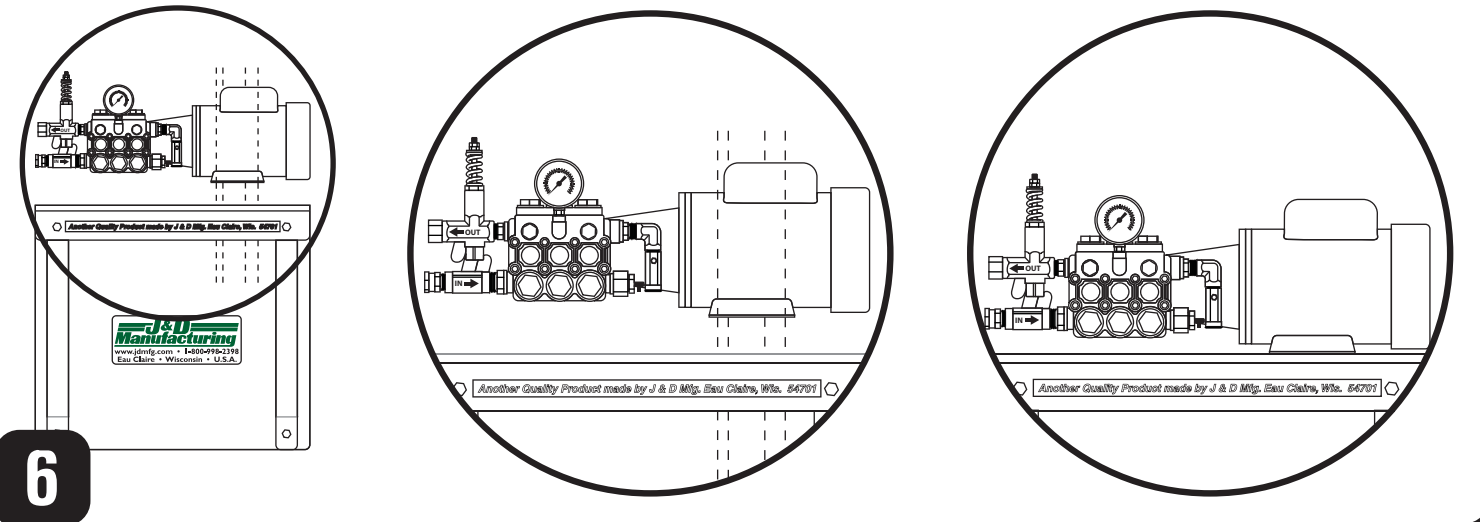

DISCONNECT POWER BEFORE INSTALLING OR SERVICING.



**ALL ELECTRICAL WORK SHOULD BE COMPLETED BY QUALIFIED PERSONNEL
AND MEET NATIONAL (NEC), REGIONAL AND LOCAL ELECTRIC CODES.**

Connecting Power to the Motor

- Install manual disconnect switch inside building adjacent to motor.
- Route wire to motor with drip loop and secure. Drip loop will drain accumulated moisture away from the motor.
- Configure internal wires to match supply voltage and wire according to motor nameplate.

7

Stainless Steel Line Hanging /Securing Requirements

- 1 Stainless steel lines require support at least every 8'.
NOTE: Mounting location and hardware (not included) must be able to withstand the weight of 11 lbs per 20' of stainless steel line.

If your system does not require the use of cable clamps, proceed to Step 3.

Hanging/Securing Line Using Cable Clamps

Insert the stainless steel line into the cable clamp and using the appropriate size and type of hardware (not provided) for your structure secure cable clamp to structure.

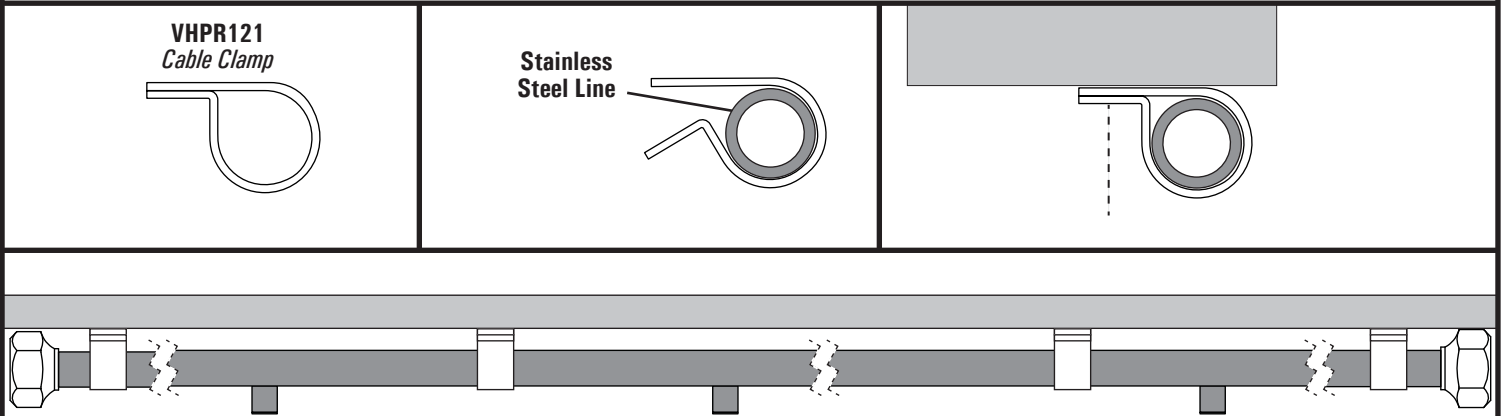

2

If your system does not require the use of suspended mounting rods, proceed to Step 5.

Hanging/Securing Suspending Rod to Structure

Using a 3/8" drill bit and drill prepare a hole for the insertion of the mounting rod (VHPR160). Remove the nylock nut from the end of the mounting rod you will be inserting, adjust the remaining flanged nut to allow enough of the mounting rod to protrude through hole to fully engage the nylock nut. Using a 1/2" wrench and a 1/2" socket wrench, secure mounting rod by tightening both nuts.

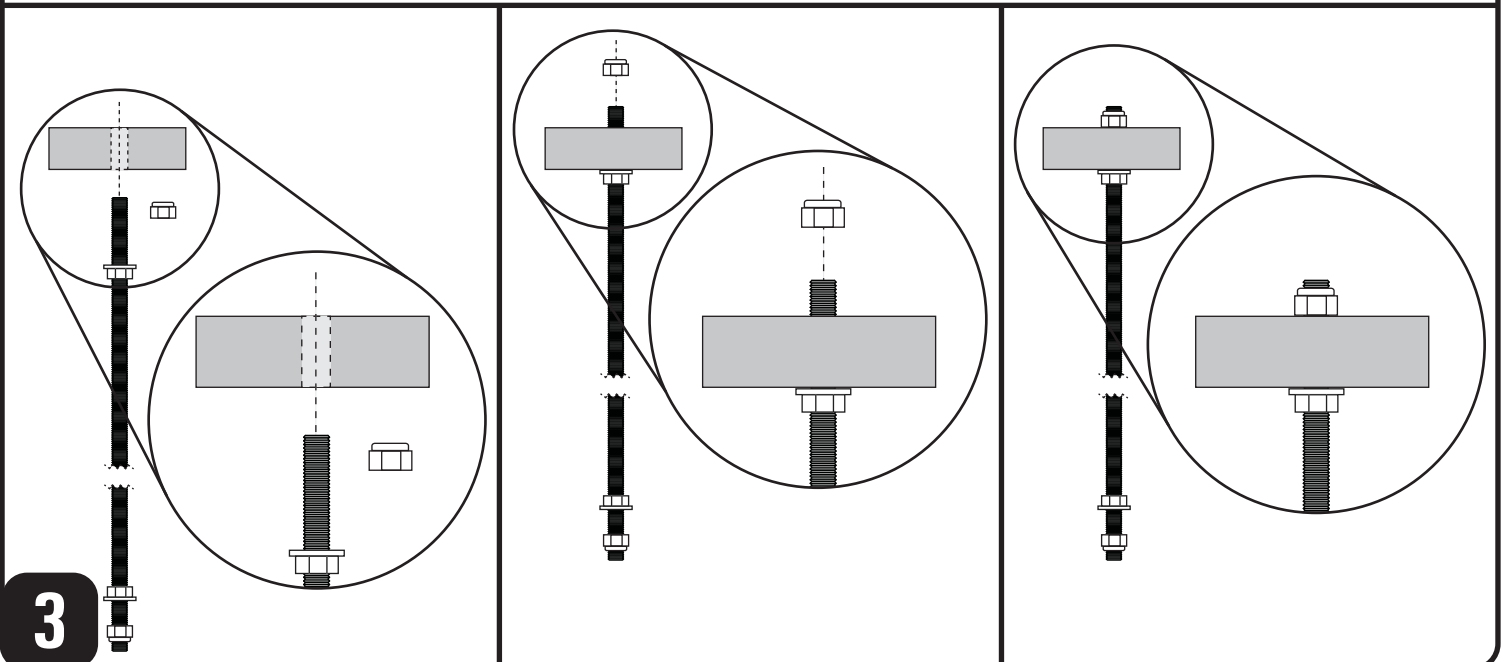

3

Securing Line to Suspending Rod with Clip

Seat stainless steel line in black poly mounting clips (VHPR159) and close flap. Remove the nylock nut from the end of the mounting rod, adjust the remaining flanged nut to allow room for the black poly mounting clip and enough of the mounting rod to protrude to fully engage the nylock nut. Using a 1/2" wrench and a 1/2" socket wrench, secure black poly mounting clip with stainless steel line to mounting rod by tightening both nuts.

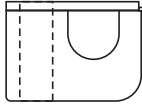
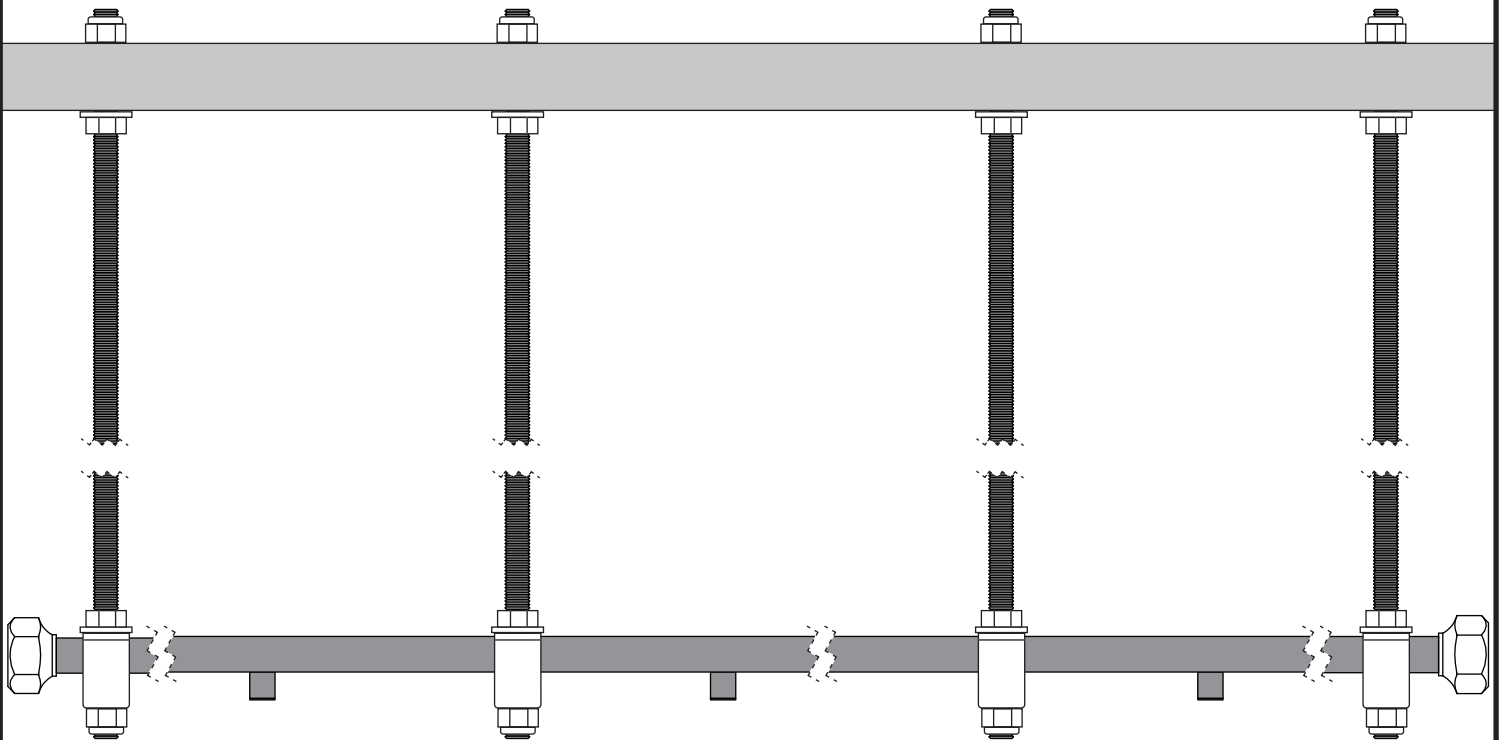
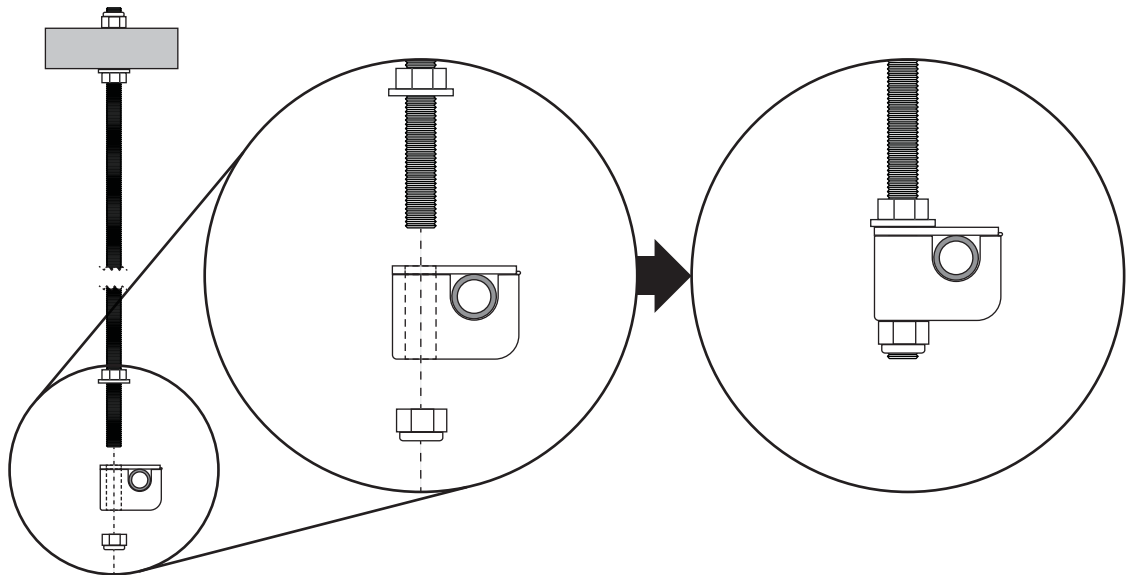
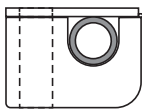
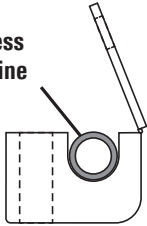
VHPR159*Black Poly Mounting Clip***Stainless Steel Line****4**

Connecting Stainless Steel Lines

Using a 3/4" wrench and crescent wrench, follow the 1/2" Flare Connector with Required O-Ring Guidelines in **Section E**. Connect stainless steel lines using union (VHPR128) and o-rings (VHPR120) as shown below.

While tightening your connection, it is important that the nozzle ports from one section of line align with the connecting section of line.

NOTE: This is an example of only one of multiple compatible connections that can be used to connect lines to each other. What is required for your system is dependent on the plan that you and your dealer laid out to fit your specific needs, refer to that plan and assemble accordingly.

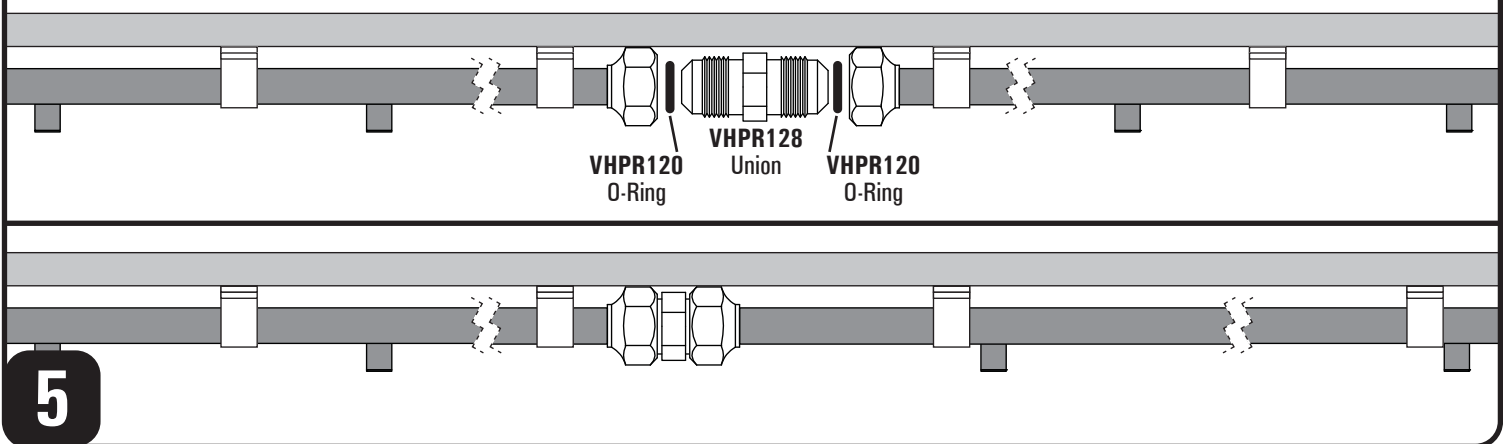

Rotating Stainless Steel Lines for Correct Nozzle Port Angle

Standard nozzle angle is 15° above level and with the direction of airflow as shown below.

NOTE: If lines do not want to remain at the angle set, due to vibration or other factors, you may find that opening a couple of mounts and wrapping that area of line with a layer or two of electrical tape and re-secure wrapped line in mount will solve the problem.

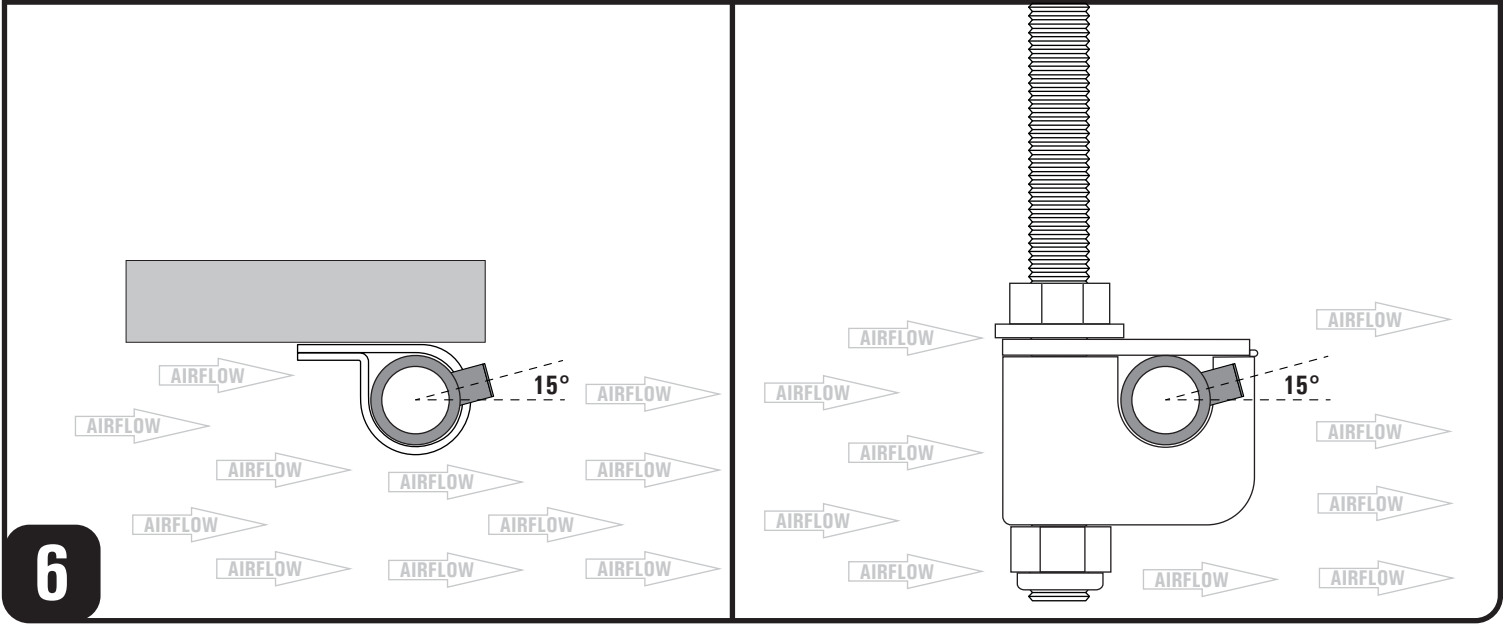

Using a 3/4" wrench and crescent wrench, follow the 1/2" Flare Connector with Required O-Ring Guidelines in **Section E** and assemble coupling (VHPR125) with O-ring (VHPR120) to the end of a stainless steel line as shown below.

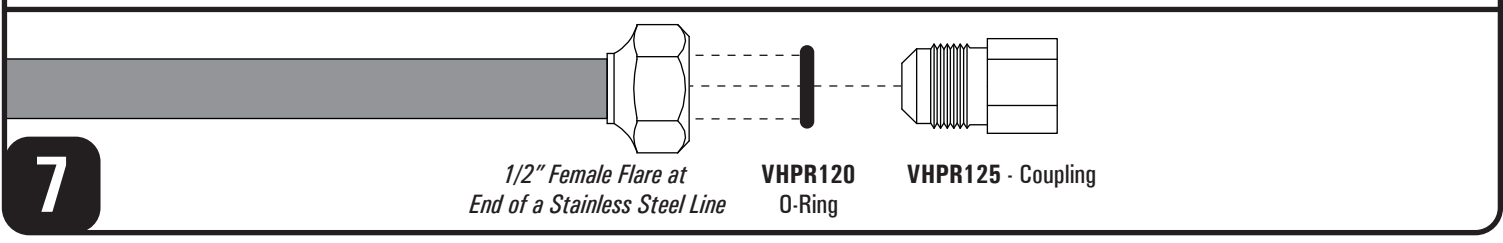

Using (2) 3/4" wrenches, follow the PTFE Tape & Tightening Guidelines in [Section E](#) to assemble adapter (VHPR123) to coupling installed in [Step 7](#) as shown below.

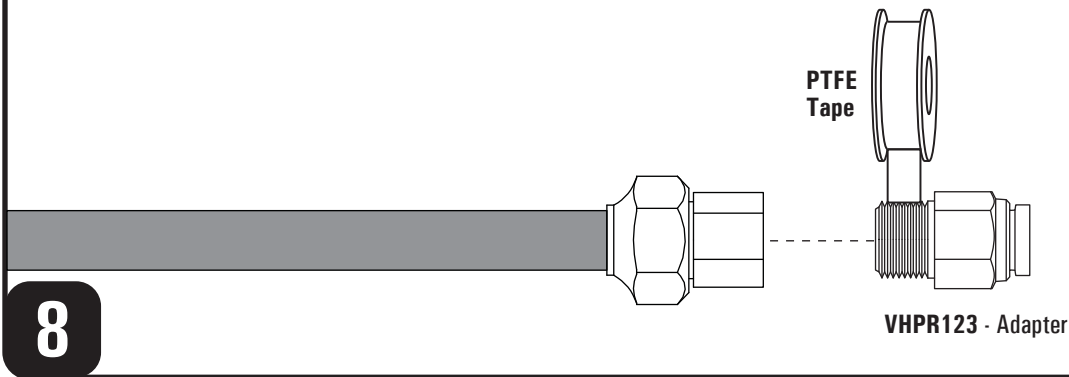

Following the Slip Lock Guidelines in [Section E](#), insert 3/8" High Pressure Nylon Tube into assembly from [Step 8](#) as shown below.

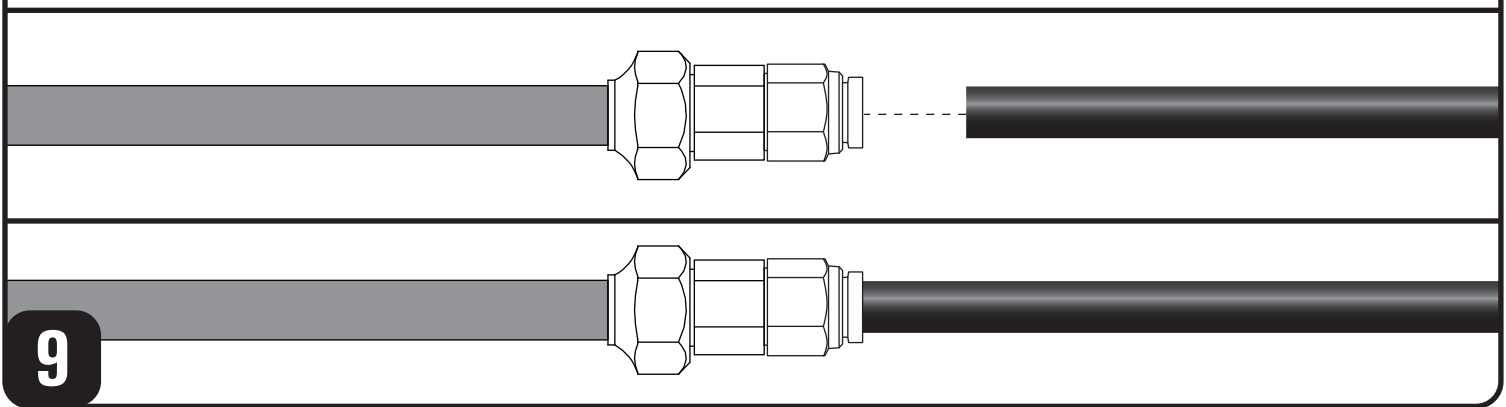

Do not install nozzles at this time. Nozzles are not installed until after Flushing System, [Section 0](#).



DISCONNECT POWER TO FAN AND WATER PUMP MOTOR BEFORE INSTALLATION OR SERVICING



A powered unit can start automatically causing severe injury or even death.

Attaching Ring Mounting Brackets to a 50", 55", or 60" J&D Panel Fan

Using a 9/16" wrench and 9/16" socket, remove the outer most hex bolt, washer and nylock nut from each corner of the J&D panel fan as shown below.

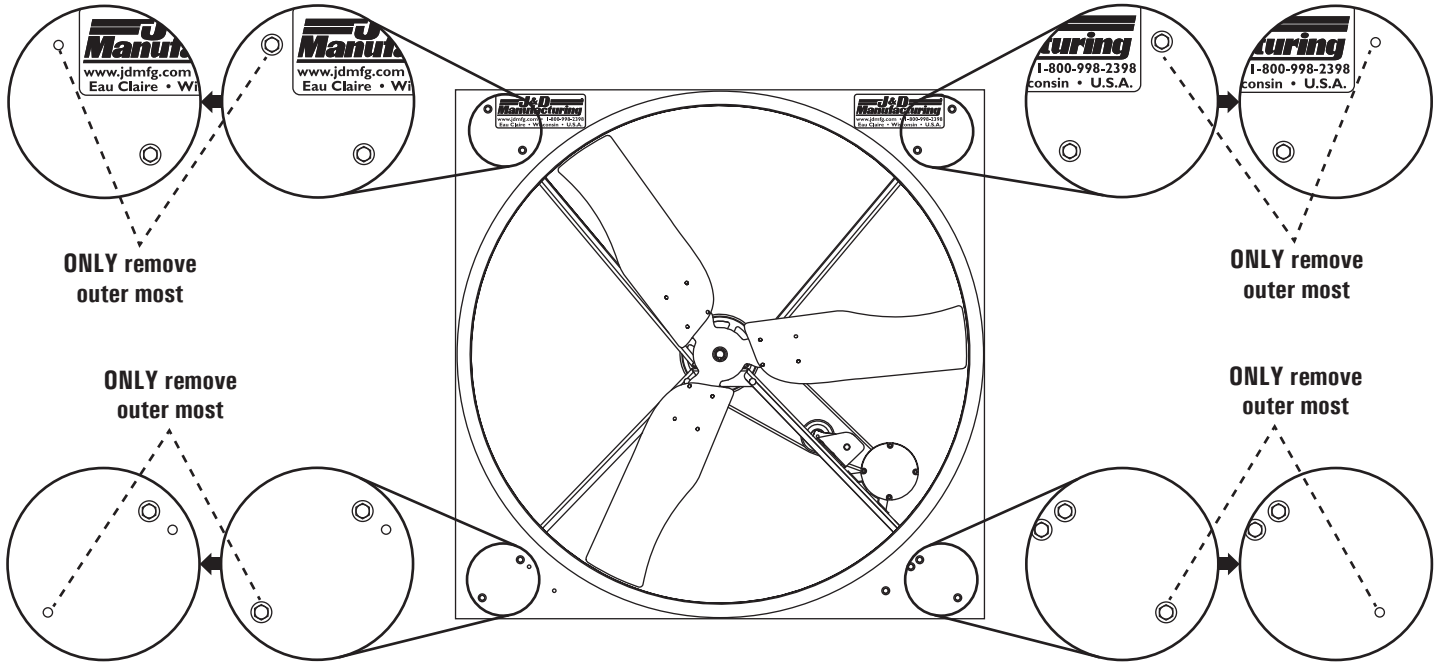

Using the hardware just removed, secure the (2) ring mounting brackets to the J&D panel fan with the hanging pegs in the locations shown below.

Once mounting brackets are installed, secure where they crossover each other with (1) cable tie. Trim off excess cable tie.

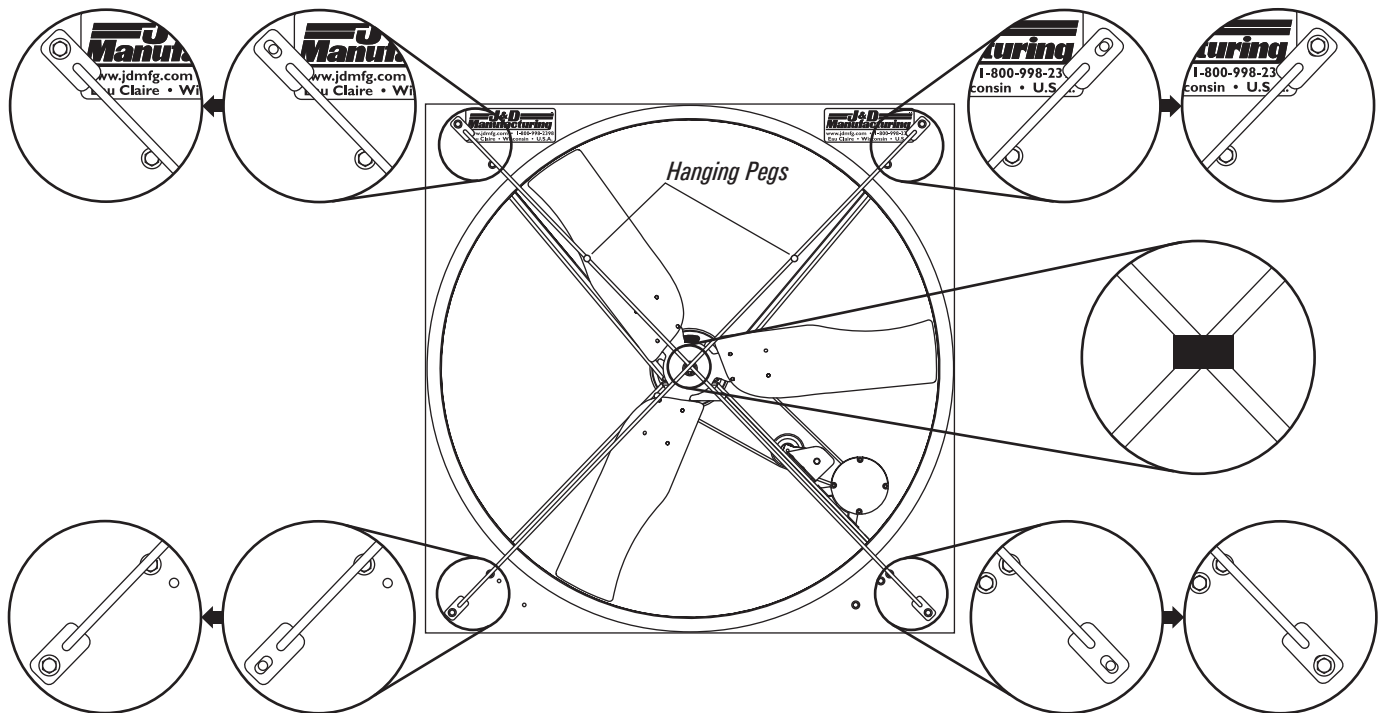

Assemble Ring

Following the PTFE Tape and Tightening Guidelines in **Section E**, tape and assemble threaded adapter (VIEC1000M) to ring connection.

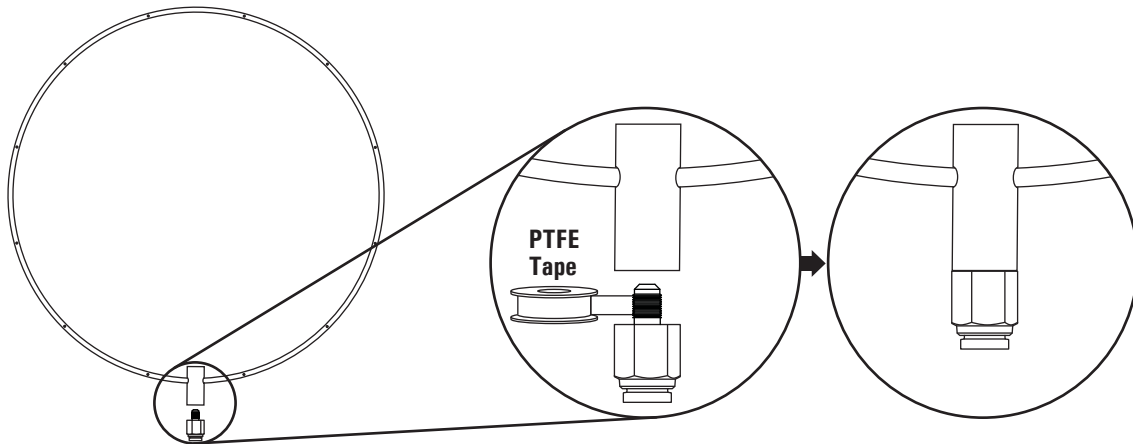
**2****Attach Ring to Mounting Brackets**

Using the hanging pegs on the mounting brackets, hook the top of the ring for correct placement and secure ring to the mounting brackets using (4) cable ties as shown below. Once ring is secure, trim excess off cable ties.

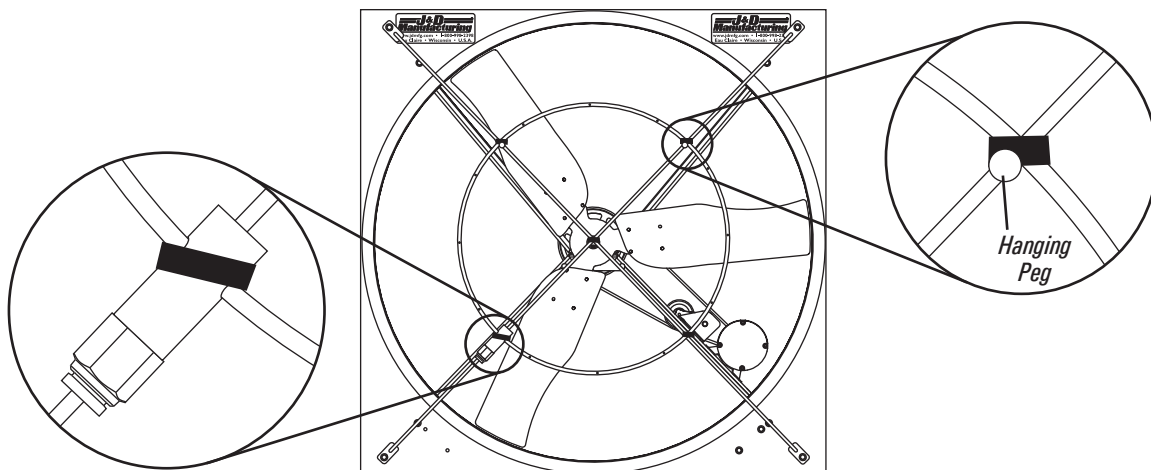
**3****Connecting Ring to System**

Following the Slip Lock Guidelines in **Section E**, connect ring to 3/8" High Pressure Nylon Tube.

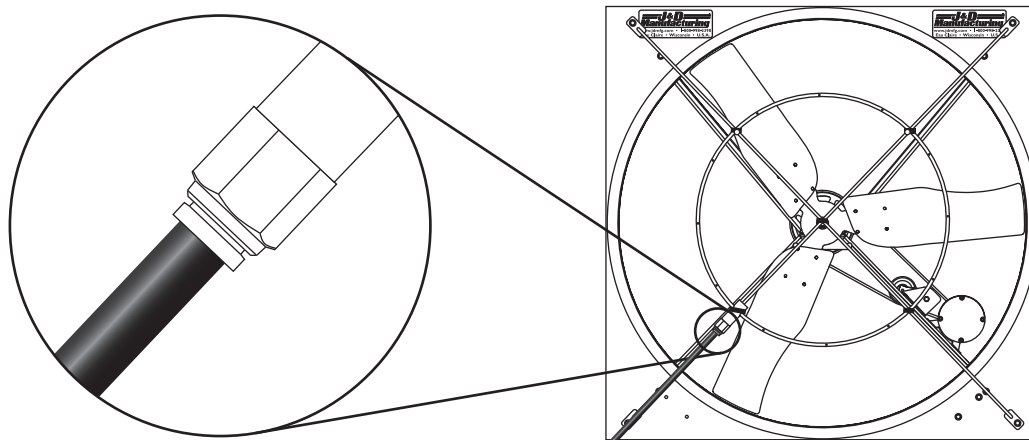
**4**

Do not install nozzles at this time. Nozzles are not installed until after Flushing System, Section O.



DISCONNECT POWER TO FAN AND WATER PUMP MOTOR BEFORE INSTALLATION OR SERVICING



A powered unit can start automatically causing severe injury or even death.

Assemble Ring

Following the PTFE Tape and Tightening Guidelines in [Section E](#), tape and assemble threaded adapter (VIEC1000M) to ring connection.

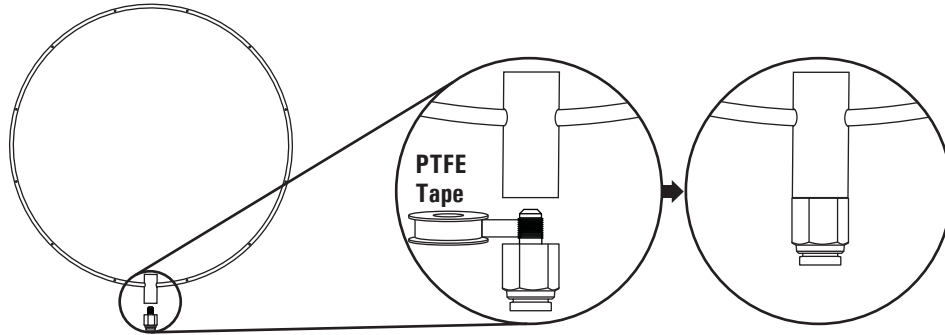

1

Attach Ring to (36" or Larger) Basket Fan

Center the ring on the fan. Using (6) cable ties evenly spaced around the ring, secure ring to fan guard. Once ring is secure, trim excess off cable ties.

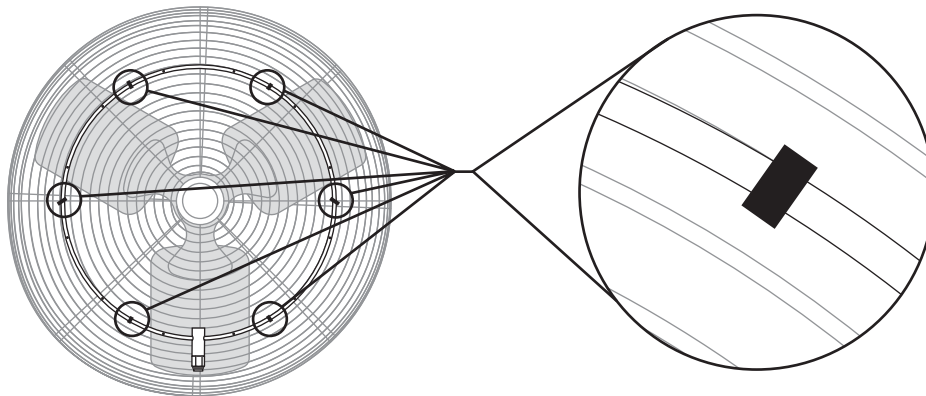

2

Connecting Ring to System

Following the Slip Lock Guidelines in [Section E](#), connect ring to 3/8" High Pressure Nylon Tube.

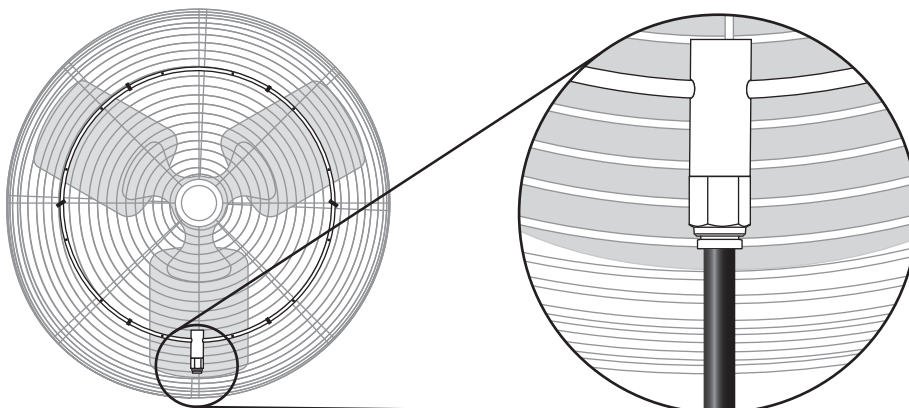

3

Do not install nozzles at this time. Nozzles are not installed until after Flushing System, [Section O](#).



DISCONNECT POWER TO FAN AND WATER PUMP MOTOR BEFORE INSTALLATION OR SERVICING



A powered unit can start automatically causing severe injury or even death.

Attaching Cross to Fan

Center the cross on the fan. Using (1) cable tie per cross arm secure cross to fan guard. Once cross is secure trim, excess off cable ties.

**SS36SH - 13" 4 Way
High Pressure Fog Cross**

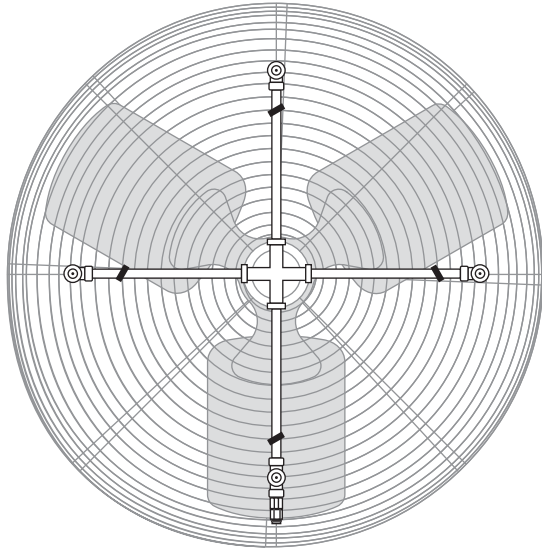

**SS36SH6 - 13" 6 Way
High Pressure Fog Cross**

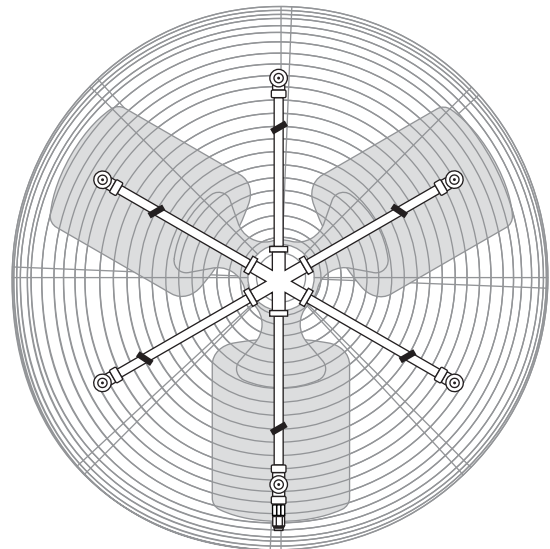

1

Do not proceed to Step 2 until after completing Section 0 Flushing System or you risk plugging the cross nozzles .

Connecting Cross to System

Following the Slip Lock Guidelines in Section E, connect cross to 3/8" High Pressure Nylon Tube.

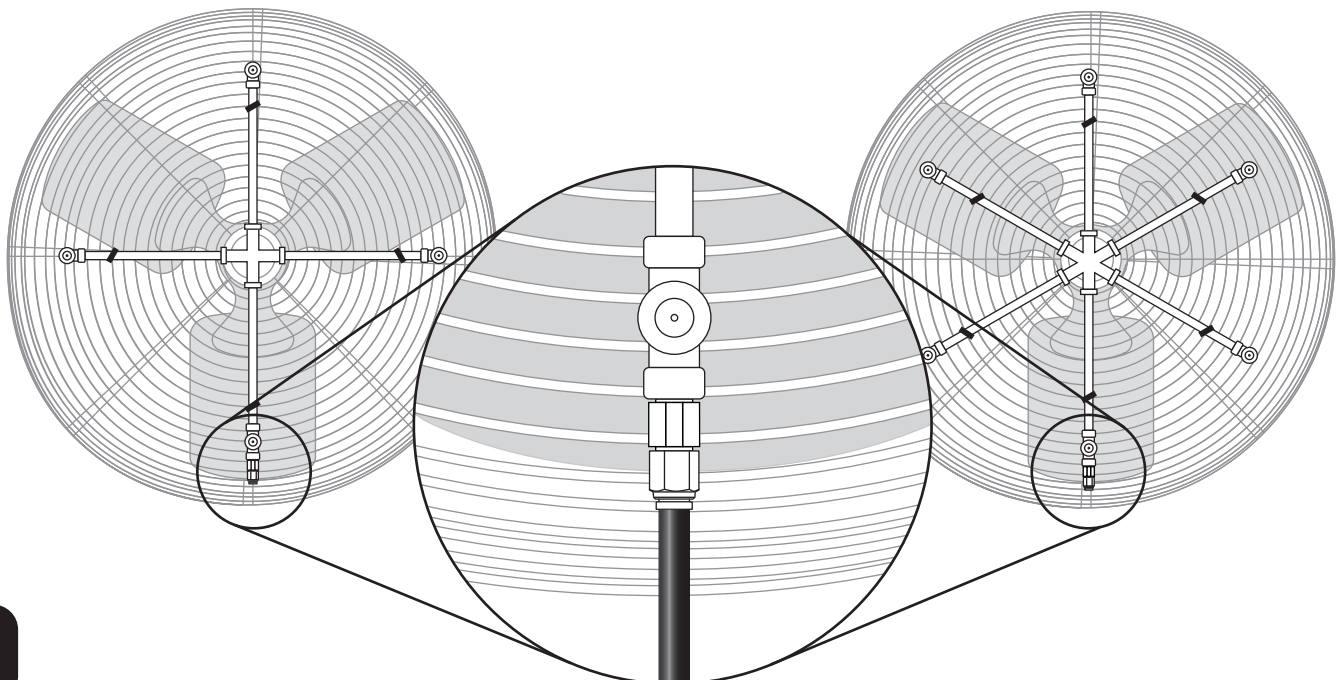

2

NOTE: Only one auto drain kit per each pump system.

The auto drain kit should be installed at the end of a run preferably the furthest from the pump.

Care should be taken to ensure that water that drains from the end of this kit is directed to a location that will not cause slipping, mold issues, wet bedding, or feed contamination.

If system will be winterized with RV antifreeze, proceed to **Step 3** as a 2000 psi Ball Valve (VHPR163) will need to be installed between the end of the line and the Auto Drain Kit.

Using a 3/4" wrench and crescent wrench, follow the 1/2" Flare Connector with Required O-Ring Guidelines in **Section E** and assemble coupling (VHPR125) with O-ring (VHPR120) to the end of a stainless steel line as shown below.

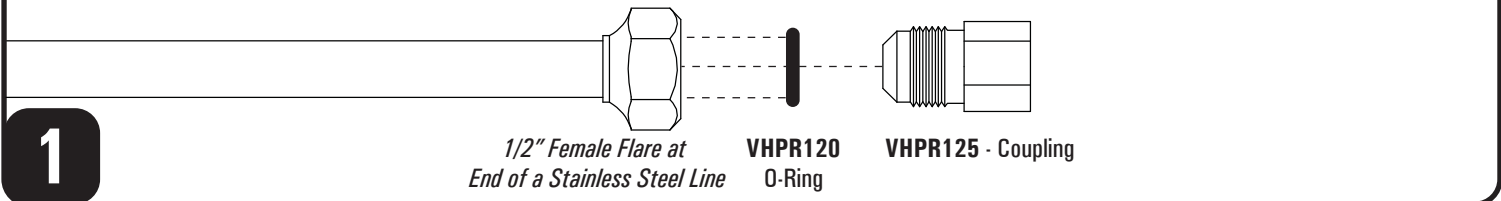

Using (2) 3/4" wrenches, follow the PTFE Tape & Tightening Guidelines in **Section E** to assemble adapter (VHPR123) to coupling installed in **Step 1** as shown below.

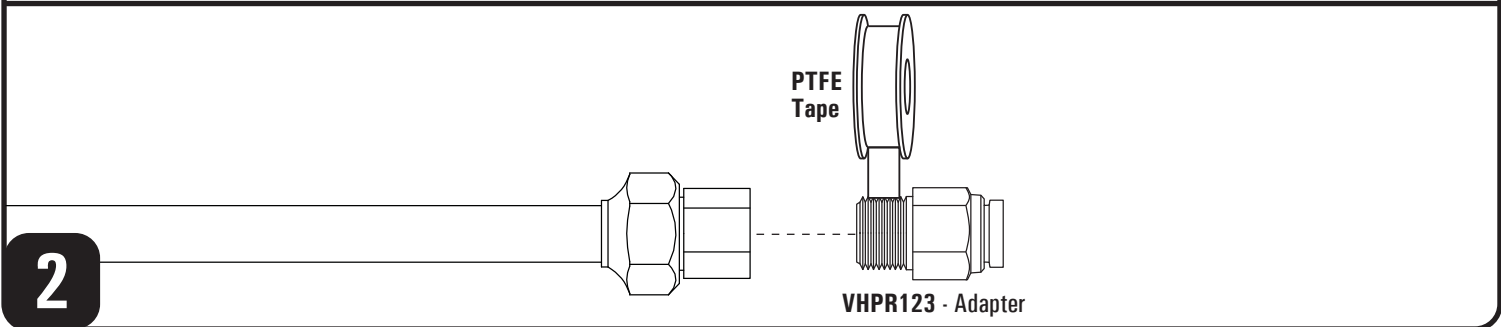

If system will **NOT** be winterized with RV antifreeze proceed to **Step 7**.

Using a 3/4" wrench and crescent wrench, follow the 1/2" Flare Connector with Required O-Ring Guidelines in **Section E** and assemble union (VHPR129) with O-ring (VHPR120) to the end of a stainless steel line as shown below.

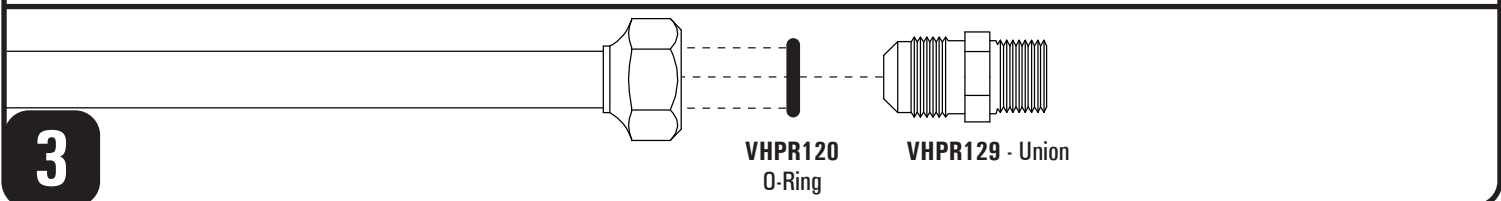

Using (2) 3/4" wrenches, follow the PTFE Tape & Tightening Guidelines in **Section E** to assemble ball valve (VHPR163) to coupling installed in **Step 3** as shown below.

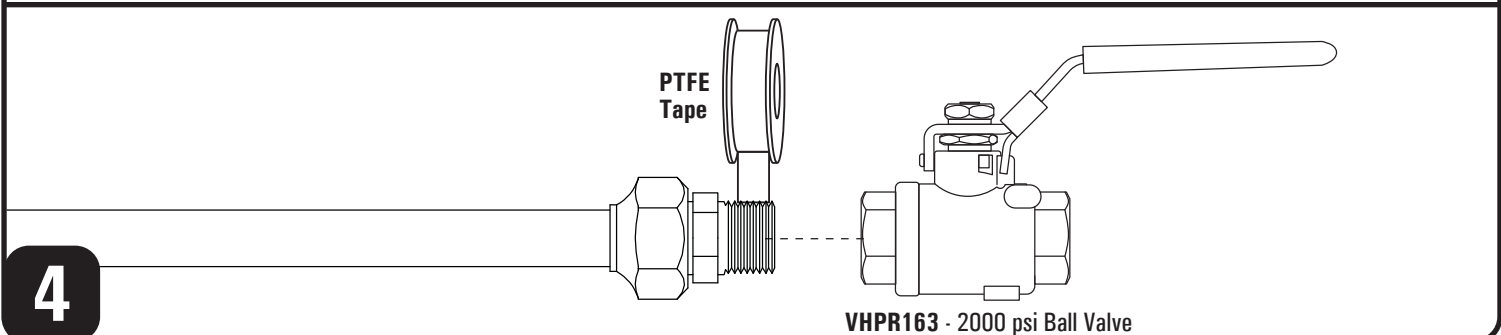

Using (2) 3/4" wrenches, follow the PTFE Tape & Tightening Guidelines in [Section E](#) to assemble adapter (VHPR123) to ball valve installed in [Step 4](#) as shown below.

5

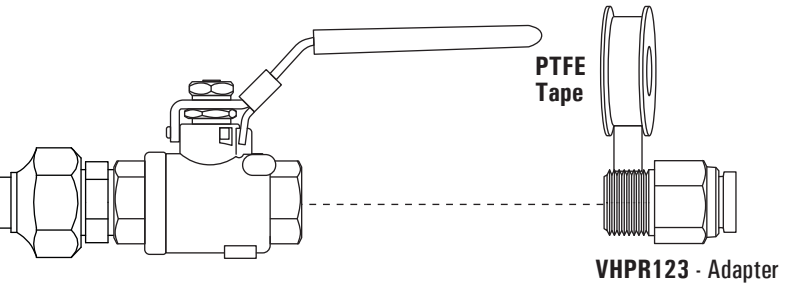

Following the Slip Lock Guidelines in [Section E](#), use a 3/8" High Pressure Nylon Tube connect tee (VIEC1000C) to assembly from [Step 5](#) as shown below.

6

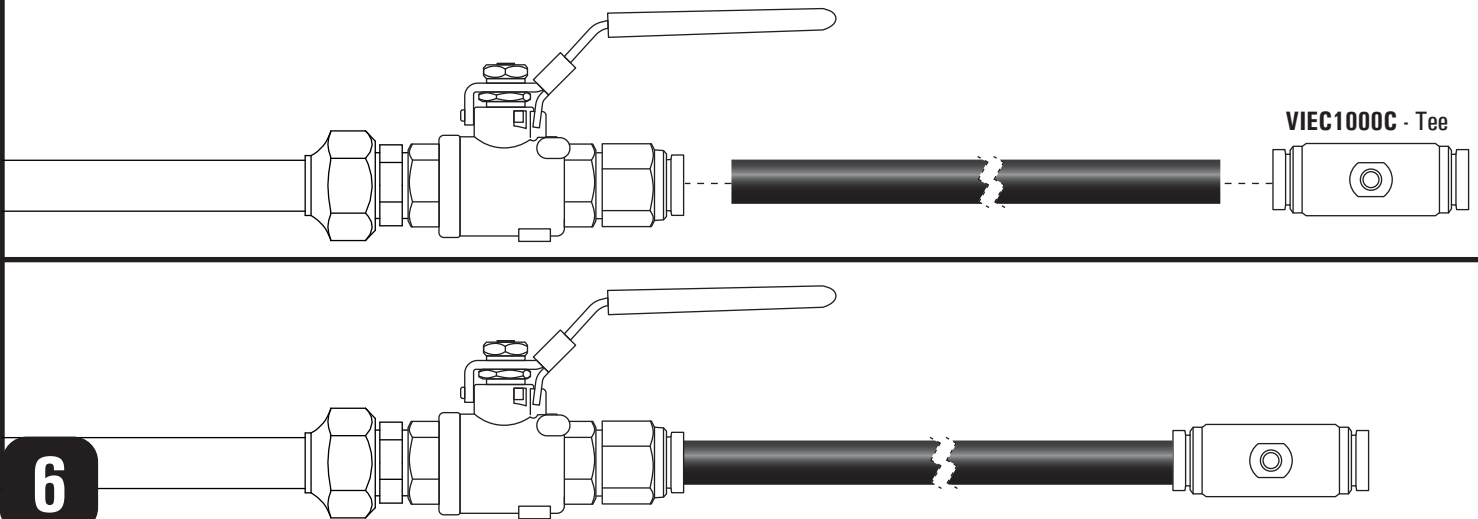

If ball valve was installed, skip [Step 7](#) and proceed to [Step 8](#) .

Following the Slip Lock Guidelines in [Section E](#), use a 3/8" High Pressure Nylon Tube connect tee (VIEC1000C) to assembly from [Step 2](#) as shown below.

7

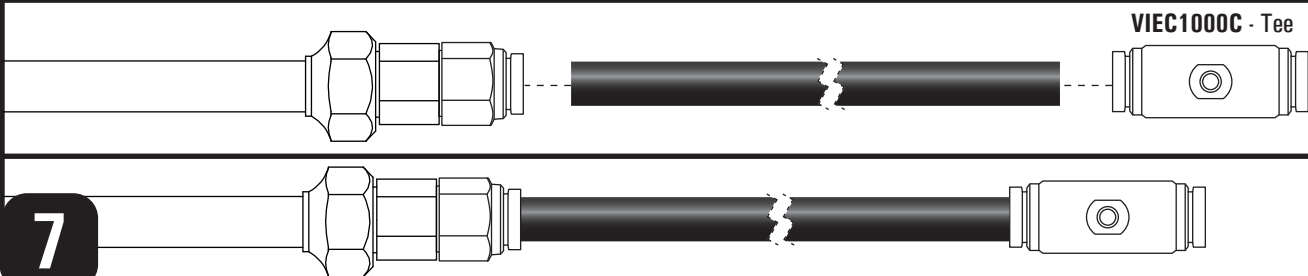

Insert plug (VIEC1000G) into the slip lock end of the previously assembled tee (VIEC1000C) as shown below.

8



Do not install nozzles at this time. Nozzles are not installed until after Flushing System, [Section 0](#) .

Using (2) 3/4" wrenches, follow the PTFE Tape & Tightening Guidelines in [Section E](#) to assemble (VHPR148) Brass Adaptor 3/4" ID Barb x 3/4" Male Hose Thread to pump "IN" port as shown below.

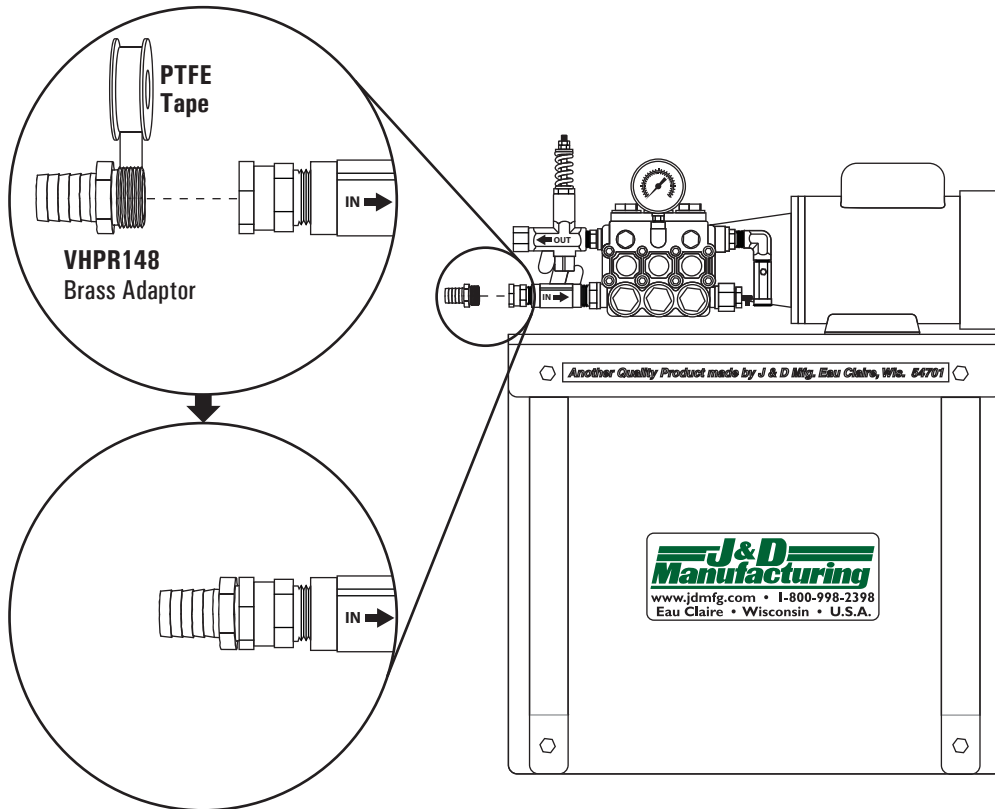

1

Using (2) 3/4" wrenches, follow the PTFE Tape & Tightening Guidelines in [Section E](#) to assemble (VHPR123) Adaptor 3/8" Slip Lock x 3/8" MIPT to pump "OUT" port as shown below.

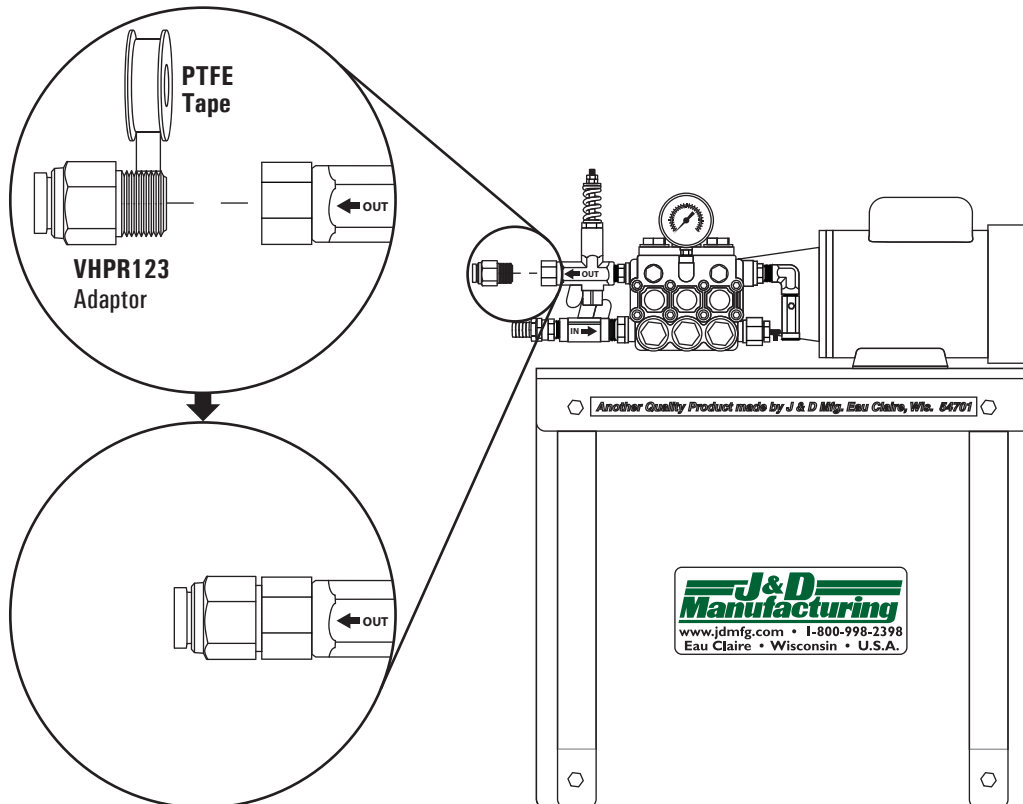

2

Connecting Filtration System to Pump

Slide (2) VHPR145 Hose Clamps on to the VHPR152 3/4" Braided Hose. Slide one end of braided hose onto the hose barb coming from the filter system and the other end onto the barb going into the pump as shown below. Hose should be pushed onto barbs until stopped by adapter collars.

Once hose is fully onto barbs, slide a hose clamp to 1/4" from end of installed hose. Using a flat head screwdriver, tighten clamp until secure. Repeat for other end of the hose.

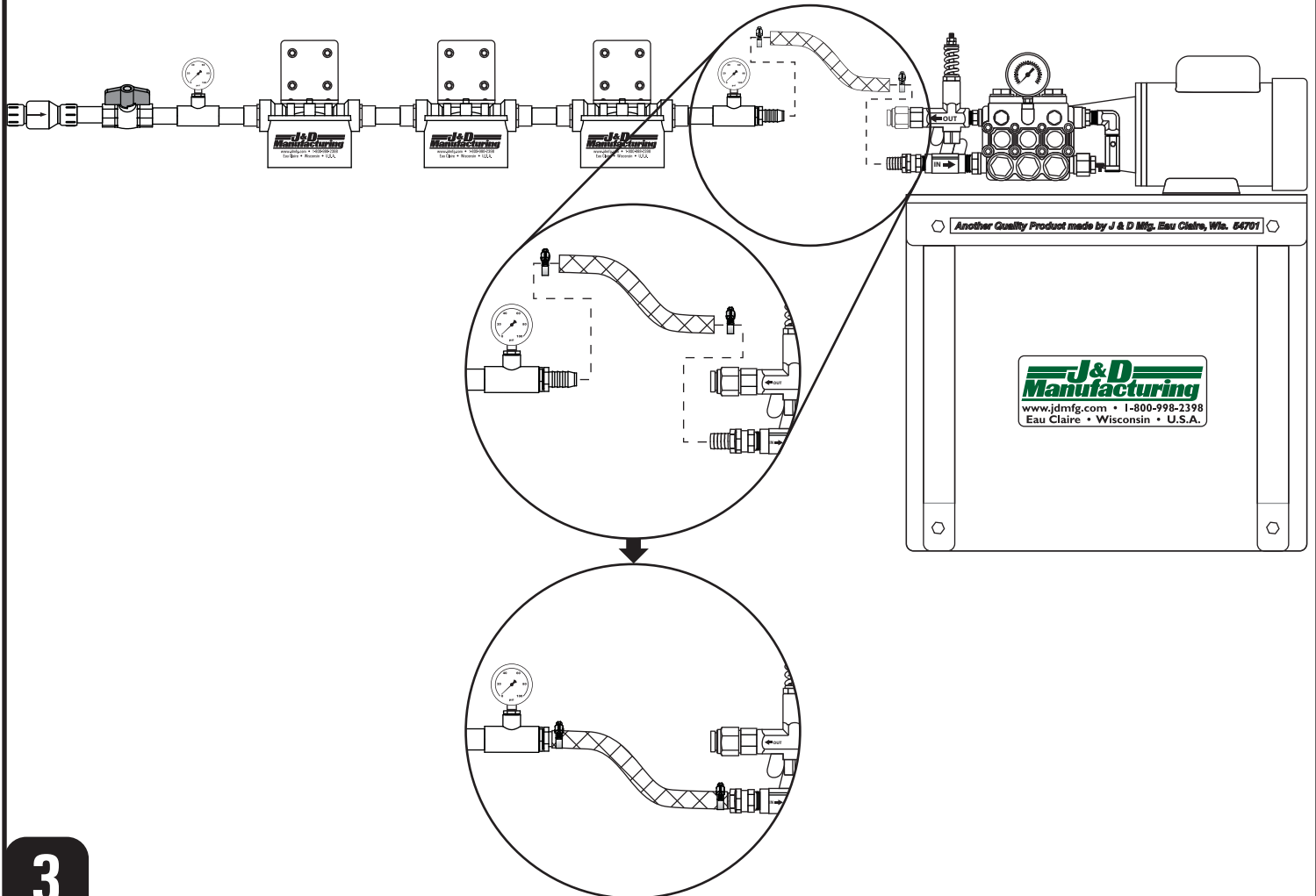
**3****Connecting Pump to System**

Following the Slip Lock Guidelines in **Section E**, connect ring to 3/8" High Pressure Nylon Tube to pump using the adapter installed in **Step 2**.

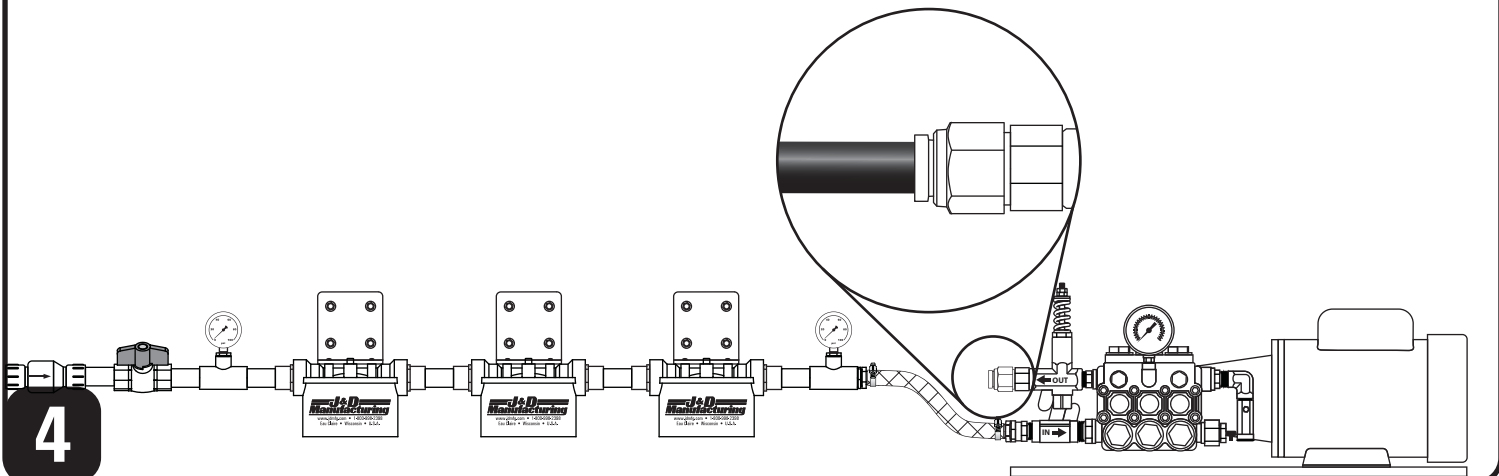
**4**

NOTICE: ---- DO NOT FLUSH SYSTEM WITH NOZZLES INSTALLED ----

Filtration System Set Up for System Flushing

Assemble and install the 20 Micron Filter and housing as shown below. (If o-ring is dry, lubricate with a small amount of petroleum jelly.) Filter housings have a positive thread stop, use filter wrench and **DO NOT OVER TIGHTEN**.

The remaining housings WITHOUT filters are installed at this time.

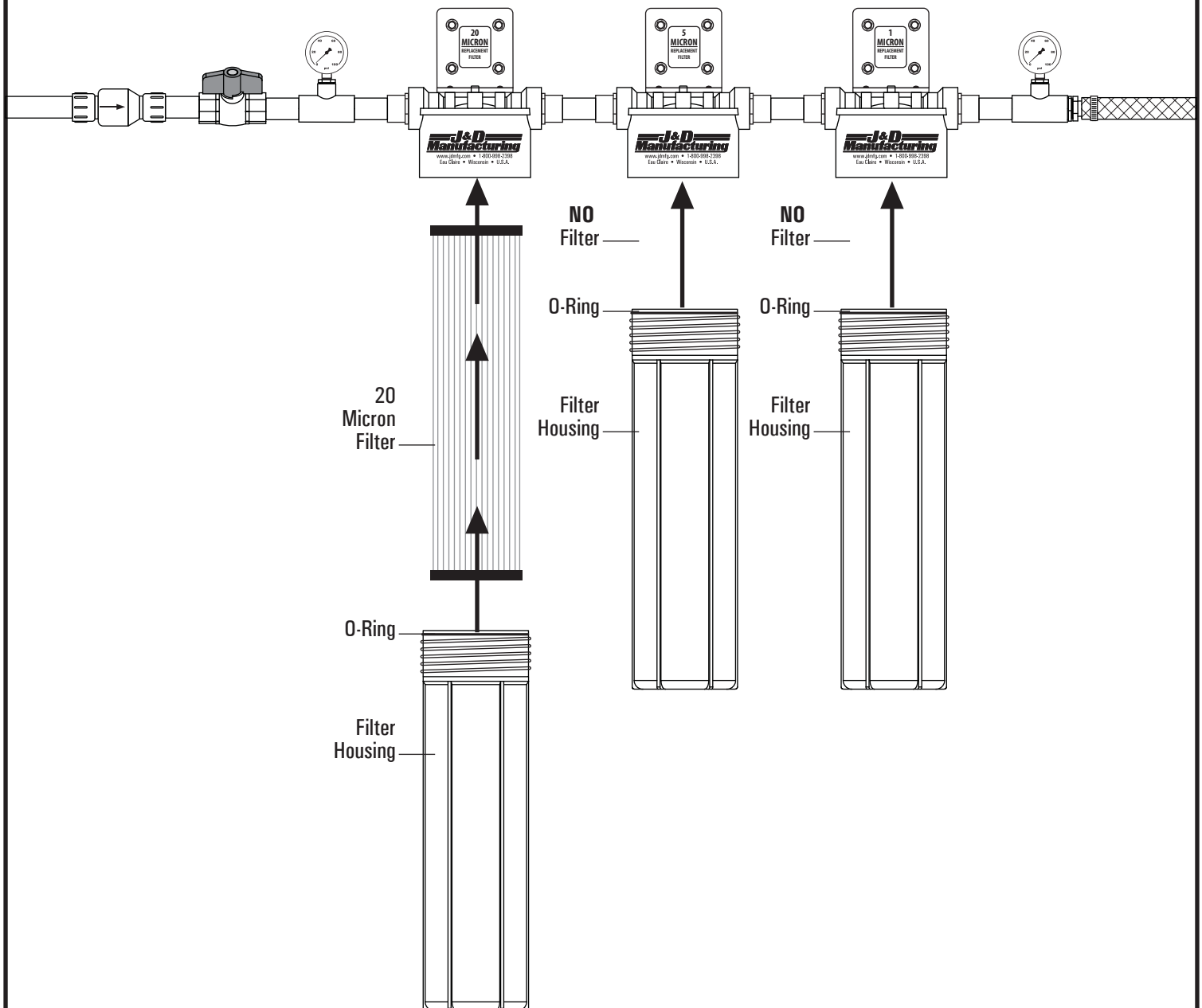

Flushing System

Open water valve/s and allow filter system to fill, then power pump and motor.

Observe location furthest from pump. Once water starts to flow from that location let system run at least an additional 7-10 minutes.

Proceed to **Section P**.

WARNING

Precautions should be taken to ensure that water will not come in contact with electrical cords or outlets as this may result in severe injury or even death.

After Flushing System - De-pressurize Filter System

Remove power from pump and close ball valve as shown below.

Press down pressure relief button on top of each filtration housing cap to release pressure.

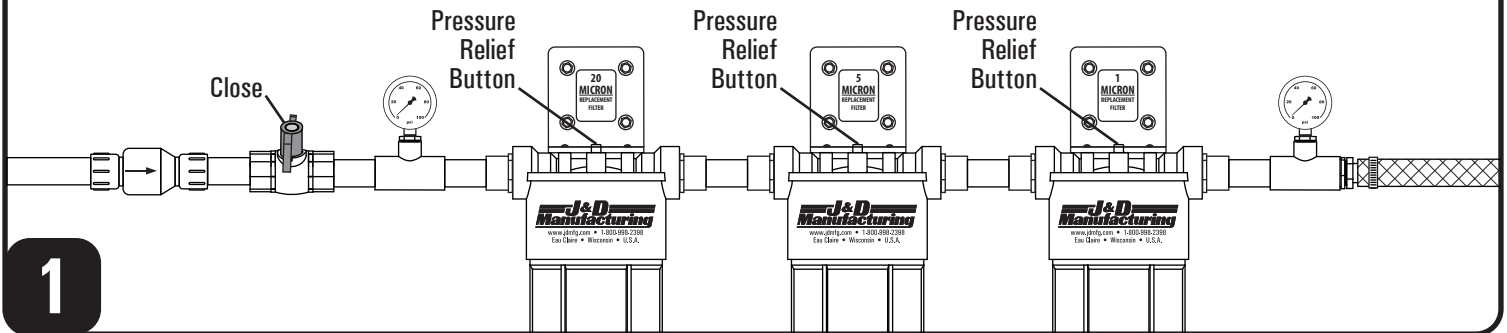
**Remove and Empty Filter Housings**

Using filter wrench, remove the bottom of all 3 filter housings and dump out the remaining water.

Remove the 20 micron filter that was installed for the flushing process in **Section O**. Inspect the filter for debris and rinse if necessary.

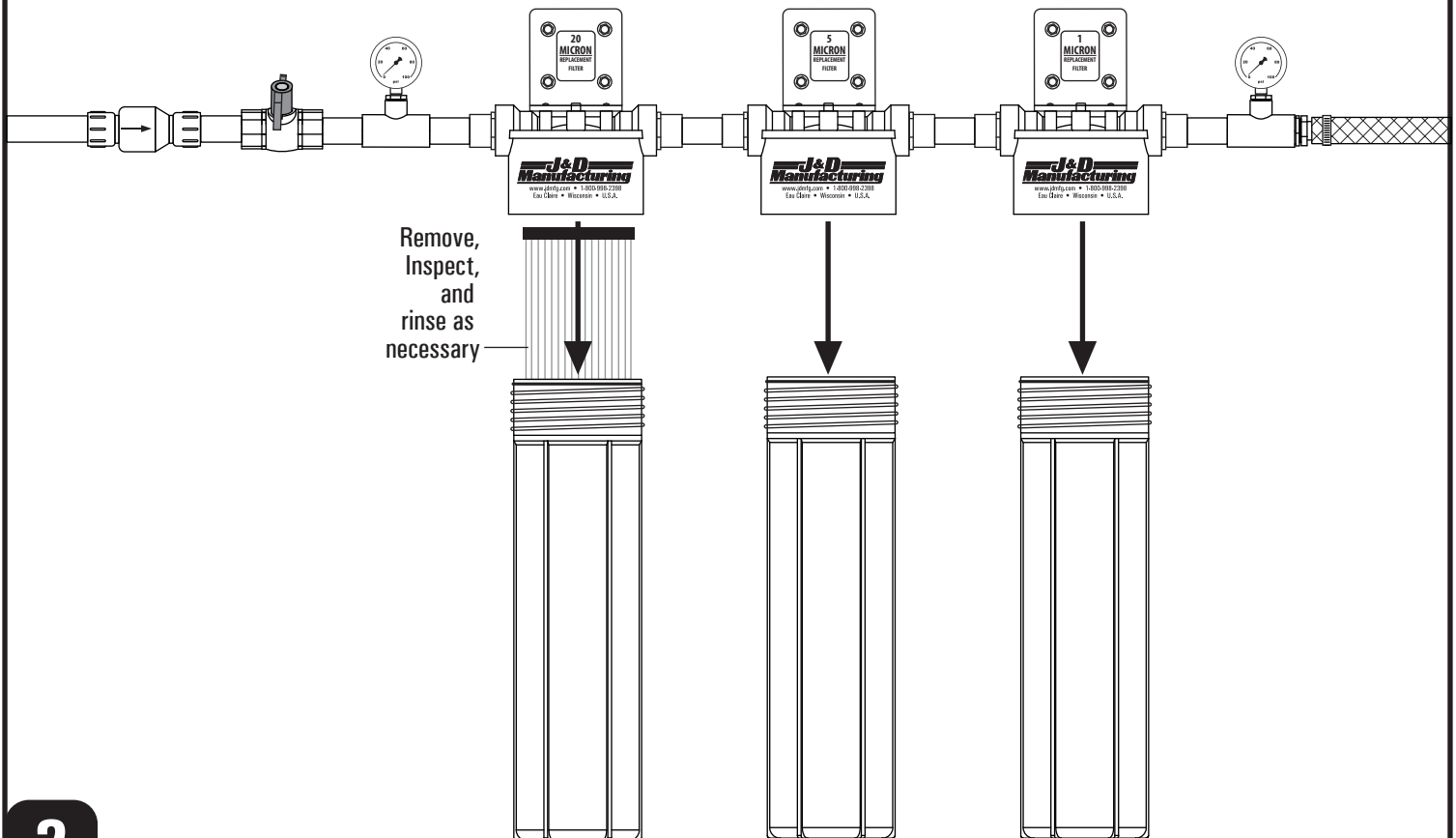

Installing Filters

Assemble and install each of the filters and housings in the order as shown below. (If o-ring is dry, lubricate with a small amount of petroleum jelly.) Filter housings have a positive thread stop, use filter wrench and DO NOT OVERTIGHTEN.

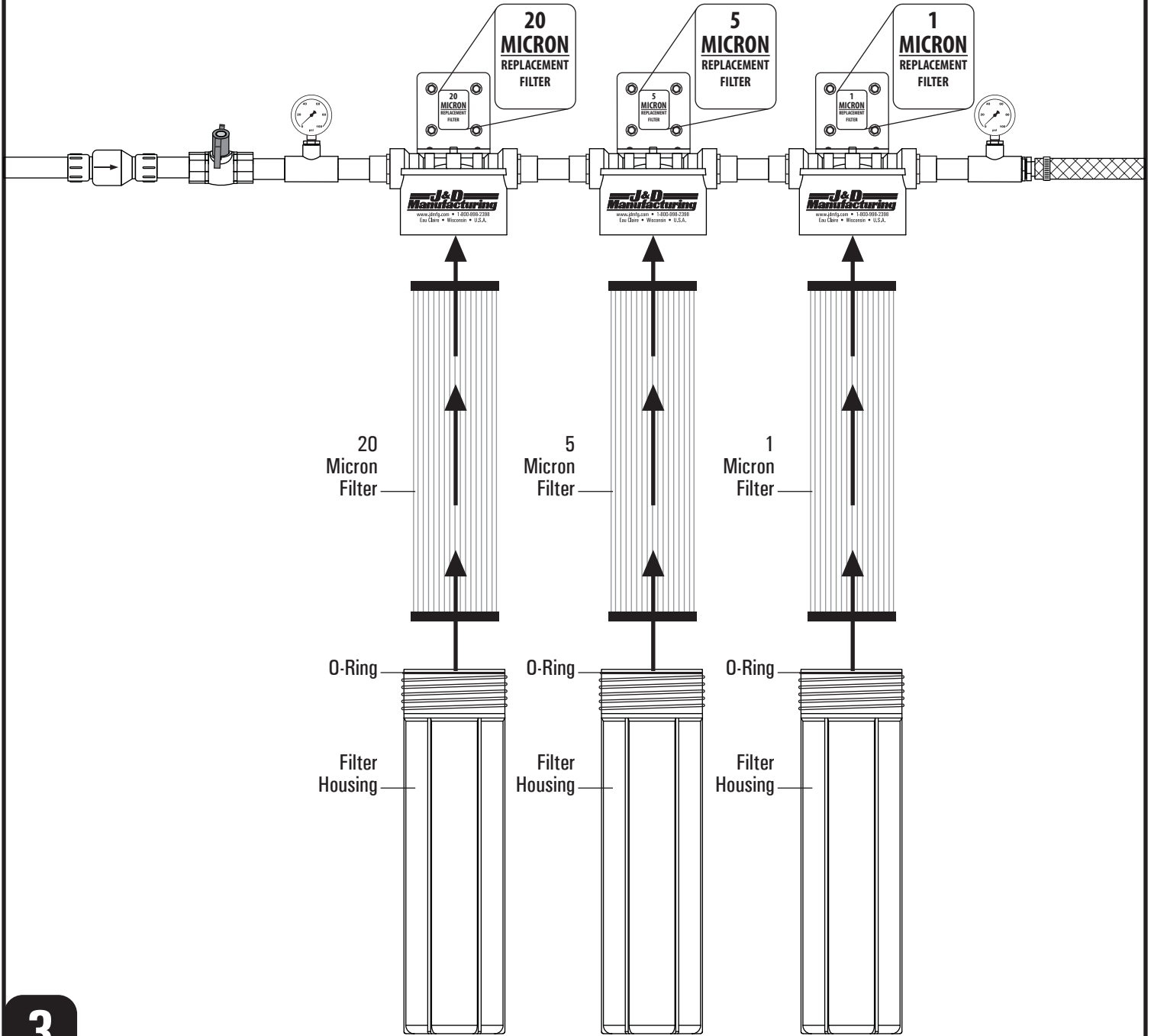

3

Nozzle Installation

Using your fingers, screw in and tighten the nozzle into the nozzle port. Hand tighten only. Tools are not recommended as they damage and overtighten the nozzles.

DO NOT OVERTIGHTEN

WARNING: Do not remove nozzles or plugs while system is running.

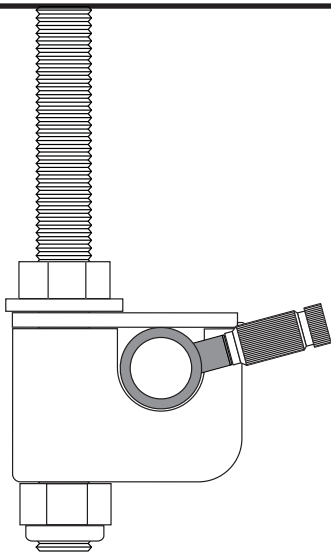
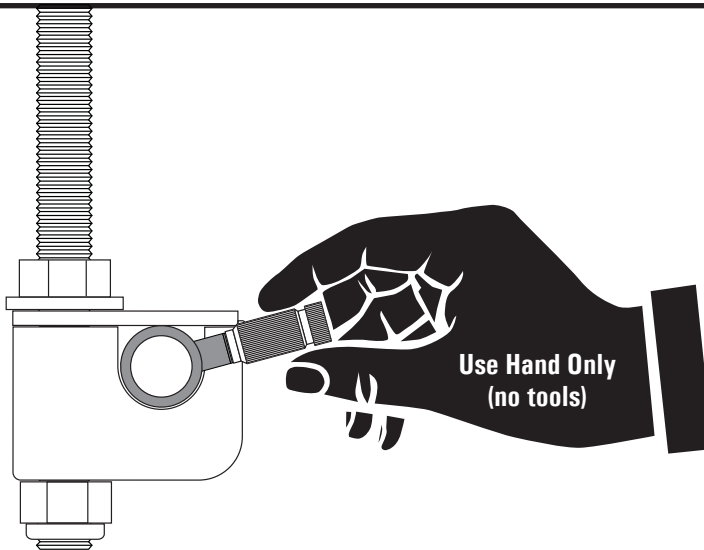
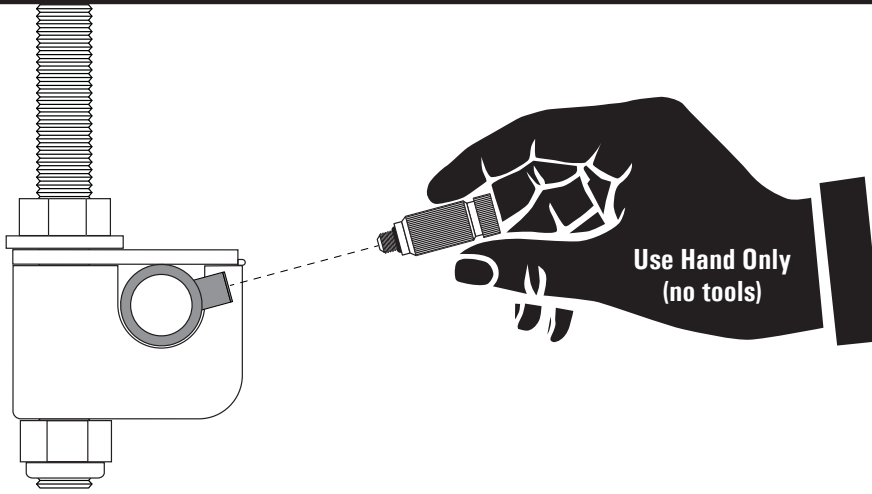

Test & Adjust System

Open ball valve and provide power to pump motor.

Allow system to pressurize. Once all nozzles are actively fogging, watch the pressure gauge on the pump and adjust the system pressure to 1,000 psi using the Adjustable Pressure Unloader. (Turning the Adjustable Pressure Unloader clockwise increases the pressure and turning it counterclockwise decreases the pressure.)

With system running, do a thorough walk through, look for and mark, leaks, areas of excess condensation, and moisture in unwanted areas. **Do not attempt to make modifications or repairs while system is running.** Areas with excess or unwanted moisture you may need to replace nozzle/s with plugs. Areas that are leaking will depend on the connection. Review the Guidelines for Assembling Components **Section E** and adjust as necessary.

WARNING: Do not remove nozzles or plugs while system is running.

Cleaning Nozzles

If cleaning more than one nozzle, separate nozzles by type and size as you remove them. Keep them separated during the cleaning process so reassembling and reinstalling after cleaning will be much easier.

WARNING: Do not remove nozzles or plugs while system is running.

Disassemble the nozzle/s as shown below.

Type: Anti Drip Nozzles

Size: 0.02 GPM
0.03 GPM
0.05 GPM

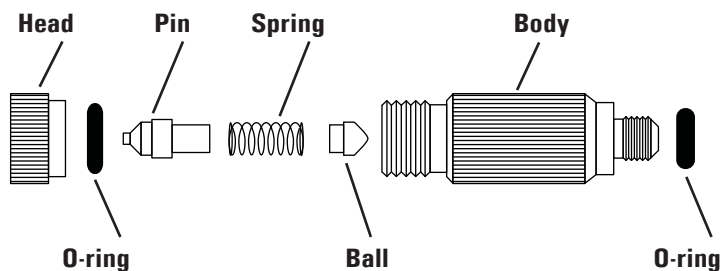
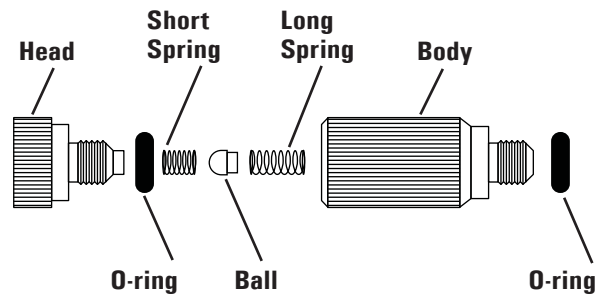
**Type: Auto Drain Valve Nozzle**

Set aside the o-rings and the ball. If necessary the o-rings and ball can be washed with slightly soapy water.

Soak the remaining metal parts in undiluted CLR® cleaner for a maximum of one hour.

Once done soaking rinse all parts thoroughly and reassemble nozzles.

Filter Maintenance

A difference of 10 psi or more is an indication to check the filters. Follow the safety warnings and steps from **Section P** when checking the filters and replacing filters.

Always start by checking the 20 micron filter first, frequently large particles will start to plug this filter. Remove 20 micron filter and flush out particles with clean running water. If filter is intact and comes clean it may be reused. Rinse out the bottom filter housing to remove any sediment that may have collected there as well. Follow the safety warnings and steps from **Section P**. Reinstall filter and turn water back on and check gauges.

If psi does not equalize, you will need to replace the 5 micron and 1 micron filters (**the 5 and 1 micron filters cannot be flushed and reused**). Rinse out bottom filter housings before installing new filters. Follow the safety warnings and steps from **Section P** when replacing filters.

Remove & Clean Nozzles

WARNING: Do not remove nozzles or plugs while system is running.

- 1** Remove and clean all nozzles, see Maintenance **Section S** for details on how to clean nozzles.
NOTE: If you separate nozzles by size and type as you remove them, reassembling and reinstalling after cleaning will be much easier.

Filter System End of Season Care

- 2**
- Disconnect the water supply line to the filter system.
 - Disconnect the hose from the filter system to the pump, leaving the hose connected to the pump.
 - Following the safety warnings and steps from **Section P**, remove and discard used filters.
 - Rinse out and reinstall the empty filter housing.
 - Check that ball valve is in the open position.

Tubes, Lines, Rings, and Crosses End of Season Care

Do not reinstall nozzles at this time.

Disconnect system from pump and using pressurized air, blow all water out of tubes, lines, rings, and crosses.

If your system is located where it can freeze you may want to provide additional protection.

Additional supplies needed:

- Pond pump
- Propylene glycol RV antifreeze for potable water systems
(For every 150' of nylon tubing and stainless steel line, a minimum of 1 Gallon will be needed.)

- 3**
- With nozzles still out of the system, begin by using pressurized air to blow all water out as mentioned above (*any water remaining in the system will dilute the RV antifreeze and reduce its effectiveness*).
 - Referring to the Nozzle Installation **Section Q** for the correct way to reinstall the nozzles, hand tightening ONLY, reinstall all the nozzles.
 - Remove the auto drain kit, cover tube opening to prevent debris from entering and store in location that is protected from freezing.
 - Using the hose that connected the high pressure pump to the filter system, connect the high pressure pump to the pond pump.
 - Submerge the pond pump into the container of RV antifreeze.
 - Provide power to the pumps - first to the pond pump then to the high pressure fogging pump.
 - Starting at the fog line closest to the pump, open the VHPR163 2,000 psi ball valve at the end of the line, once RV antifreeze runs out close it. Working your way further from the pump repeat for each fog line.

Pump End of Season Care

If your pump is located where there is no chance of freezing.

- Disconnect power to motor.
- Cap IN and OUT connectors to prevent debris from entering unit.

If your pump is located where it can freeze.

Option #1

- Disconnect power to motor.
- Cap IN and OUT connectors to prevent debris from entering unit.
- Unscrew bolts holding motor to shelf and relocate pump and motor assembly to a location that is safe from freezing.

Option#2 - is only available if winterizing entire fogging system with RV antifreeze

Once entire fogging system has been filled with UNDILUTED propylene glycol RV antifreeze for potable water systems as described in **Step 3**:

- 4**
- Keep pump connected to fogging system
 - Disconnect the pond pump from the high pressure fog pump
 - Cap IN port to pump to prevent debris from entering unit and to keep antifreeze in
 - Disconnect power to motor

Filtration System**DAILY**

Check pressure gauge at beginning of filtration system and at end of filtration system.

- A difference of 10 psi or more is an indication to check the filters, see maintenance **Section S**, Filter Maintenance.

Pump**DAILY**

Check oil for proper level (middle of the sight glass) and consistency (clear - not milky or discolored).

- If oil show signs of contamination (milky or discolored) change immediately, and replace packings.
See pump manufacturers service instructions.

Check under pump for oil leaks.

- If the pump show signs of oil leaks between crankcase/manifold, change piston rod oil seals immediately.
- If oil leaks out of the side cover, change side cover oil seals immediately.
See pump manufacturers service instructions.

Check for water leaks.

- If water leaks between crankcase/manifold, change packing assembly immediately.
- If water leaks from the valve caps, change valve cap O-rings.
See pump manufacturers service instructions.

WEEKLY

Check pressure gauge (when running) should read 1,000 psi.

- If pressure gauge is not at 1,000 psi, use the Adjustable Pressure Unloader to adjust pressure.
(Turning the Adjustable Pressure Unloader clockwise increases the pressure and turning it counterclockwise decreases the pressure.)

AFTER FIRST 50 HOURS

Change oil.

See pump manufacturers service instructions.

EVERY 500 HOURS

Change oil.

See pump manufacturers service instructions.

Motor**WEEKLY**

Clean all dust and debris off of motor and venting bell.

Nozzles**WEEKLY**

Check for plugged nozzles.

- See maintenance **Section S**, Cleaning Nozzles

WARNING: Do not remove nozzles or plugs while system is running.