

Manual or Motorized 24 Volt DC Curtain System



- Fully adjustable for minimum winter ventilation or maximum summer ventilation
- Curtain is wound tightly around the roll tube extending the life of your curtain, and eliminating the collection of debris and habitat for rodents
- Heat sealed curtain keder prevents tearing and fraying
- Keder slides easily into the roll tube for quick installation
- Manual drive with 6' or 9' shepherd's hook
- Motorized climbing drives with built in adjustable limit switches and optional protective cable guide

Table of Contents

A: Warranty & Recommended Tools	N: Standard Exterior Rigid Wind Pipe Installation
B: Parts Identification	O: Universal Adjustable Rigid Wind Pipe Installation
C: Back Panels - Identification and Assembly	P: Wind Strap System Installation
D: Center Drive Curtain with Back Panels	Q: Stretching Curtain
E: End Drive Curtain with Back Panels	R: PCSR317 Manual Drive Installation Preparation
F: Interior Wind Pipe Mounted Roll Tube Bracket - with Back Panels	S: PCSR120W & PCSR250W DC Gear Box Installation Preparation
G: Preparing the Structure for Center Drive Installation	T: Installing Climbing Pole with Curtain Drives
H: Preparing the Structure for End Drive Installation	U: Spliced Wind Pocket Assembly
I: Interior Wind Pipe Mounted Roll Tube Bracket	V: Dead End Curtain Wind Pocket
J: Top of Curtain Installation Using PCSR616 Tack Strip	W: End Drive Wind Pocket
K: Roll Tube Preparation	X: Center Drive Wind Pocket
L: Roll Tube as Curtain Hanger Installation	Y: Drive Wind Pocket Cover
M: Hanging the Curtain	

WARRANTY

J&D Manufacturing warrants all products are free from defects in materials and workmanship under normal use for the period of one year from date of purchase. Our warranty does not cover normal or regular wear and tear. J&D Manufacturing can repair or replace at our option, any product or part of the product that is found to be defective. Our warranty applies to materials only, and does not include return freight, delivery, loss or damage to personal property, cost of removal or installation, any incidental or consequential damages or labor. This warranty does not apply to products which are misused, abused, altered, improperly installed or subject to negligence. All warranties must be approved through our warranty department. The original purchaser must present a copy of the invoice for the defective product. One year is our standard warranty unless specified on our literature or in the installation instructions or user manuals.

RECOMMENDED TOOLS FOR ASSEMBLY (NOT PROVIDED)

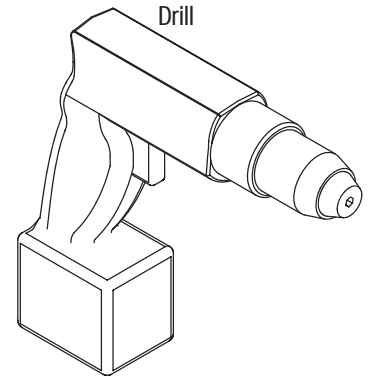
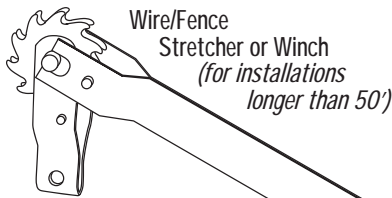

Plumb Bob



Measuring Tape

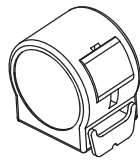

Chalk Line

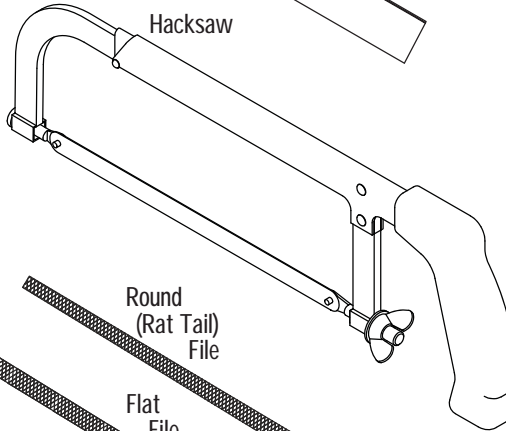
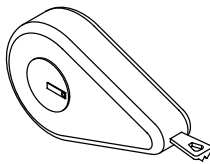

Drill Bits
 15/64"
 F=17/64" (1/4")
 P=21/64" (5/16")
 W=25/64" (3/8")
 1/2"

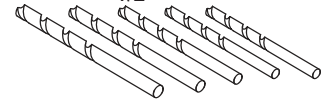

Round (Rat Tail) File

Flat File

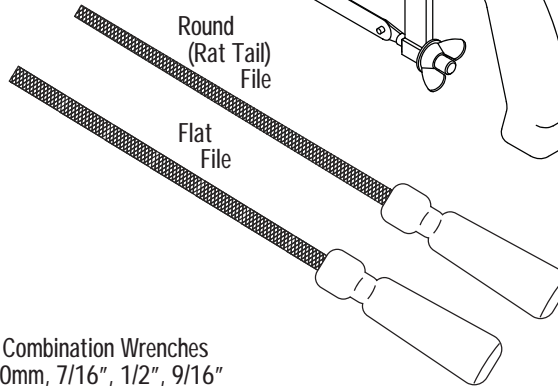

#2 Square Bit

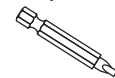

Socket Wrench

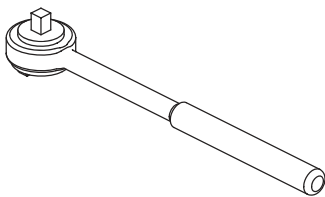

#1 and # 2 Phillips Bit

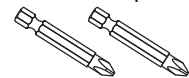

Combination Wrenches
10mm, 7/16", 1/2", 9/16"

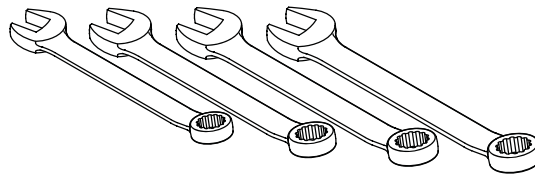

Sockets
10mm, 7/16", 3/8", 1/2", 9/16"



Socket Adapter

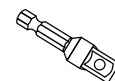

PCSR498
Curtain
Stretching
Tool

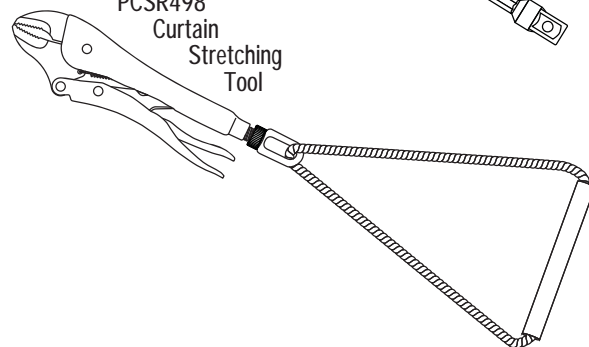

PCSR-TACK

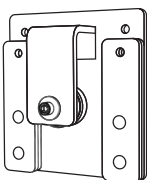

PCSR-ROLL

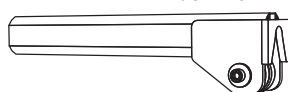

* Indicates shown to scale for ease of identification.

HK180 - Concrete Fastener Pack

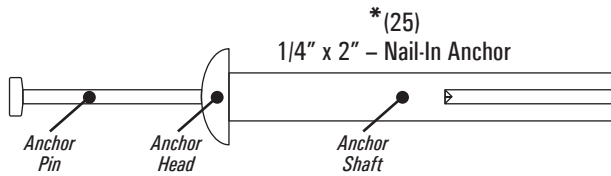

Installation:

Use Hammer Drill and 1/4" drill bit to drill hole in concrete to 2 1/2" depth.
Clean debris out of hole.

Insert anchor through item to be secured and into drilled hole, push anchor till there is no gap between concrete and item to be secured and anchor head.

Using a properly sized hammer for the diameter of the anchor, set the pin with a number of square/sharp strikes to the head of the pin until the pin is flush with the top of the anchor.

Recommended Installation Tools - (Not Provided)

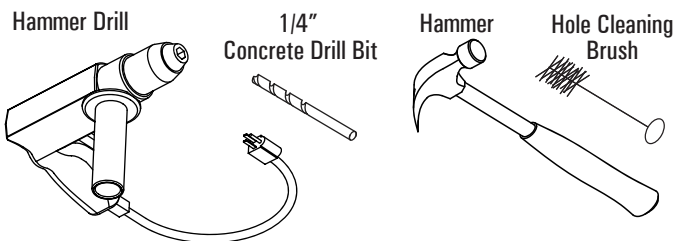

HK181 - Wood Fastener Pack

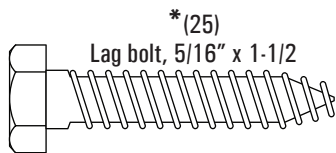

Installation:

Use a standard "F" size, 17/64" (1/4"), drill bit and drill a 1-1/2" deep pilot hole.

Secure lag bolt by using a 1/2" socket

* If steel back panels are installed you may be required to drill holes through the panel to mount brackets and tack strips. Use a standard "P" size, 21/64" (5/16") steel drill bit to create a hole in panel.

Recommended Installation Tools - (Not Provided)

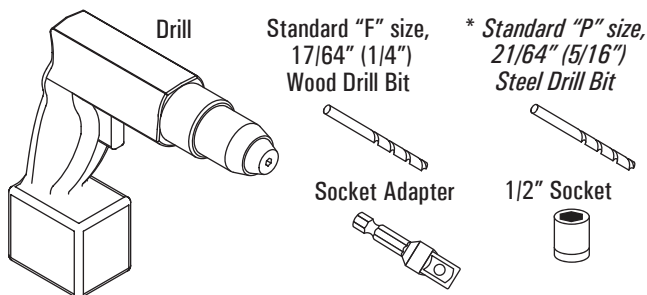

HK182 - Steel Fastener Pack

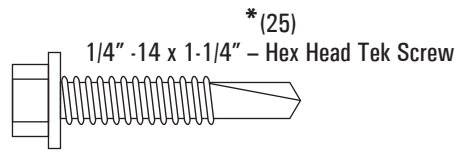

Installation:

Self-tapping, pilot hole is not needed.

Use a 3/8" socket to drive fastener.

Recommended Installation Tools - (Not Provided)

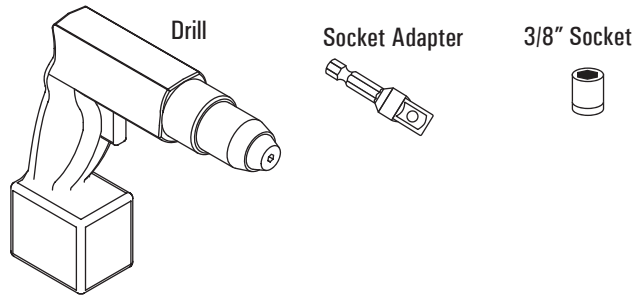

HK184 - Fastener Pack for Tack Strip/Roll Tube Bracket

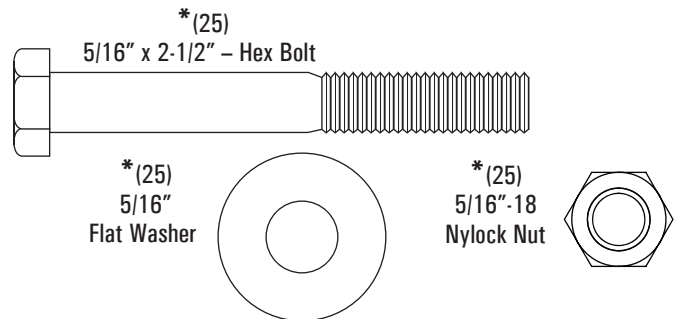

Installation:

Use a standard "P" size, 21/64" (5/16"), drill bit to drill bolt hole.

Insert bolt position washer over threaded end of bolt and secure with nylock nut.

Tighten using 1/2" socket and 1/2" wrench

Recommended Installation Tools - (Not Provided)

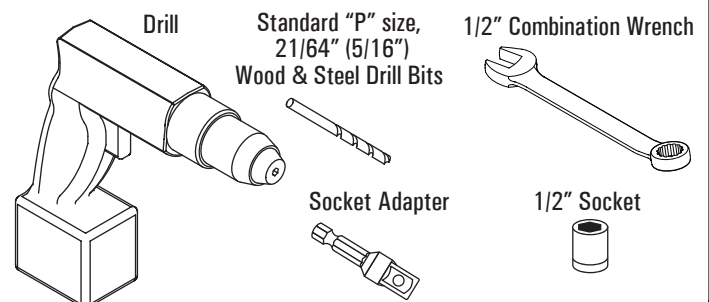

PCSR616 - 16' Curtain Tack Strip

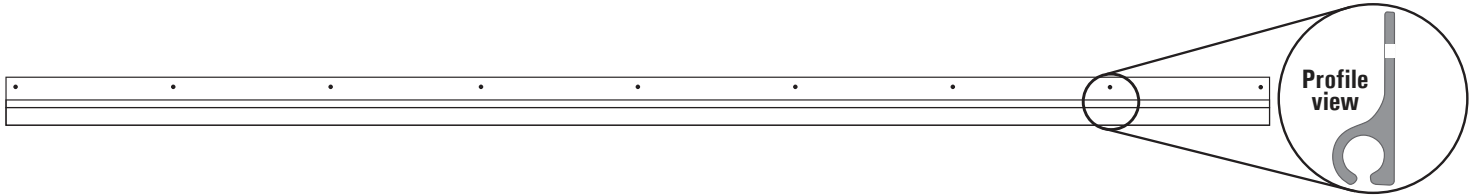

PCSR600 - 16' Curtain Roll Tube

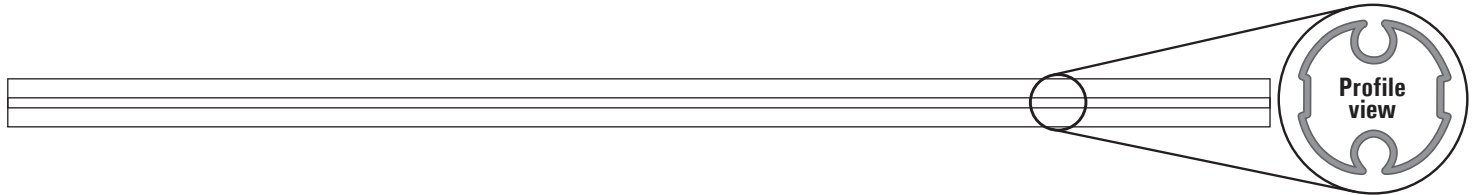

PCSR617 Roll Tube Mounting Bracket

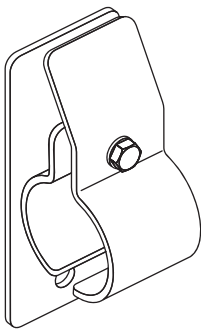

PCSR605-P 12" Roll Tube Splice with Hardware

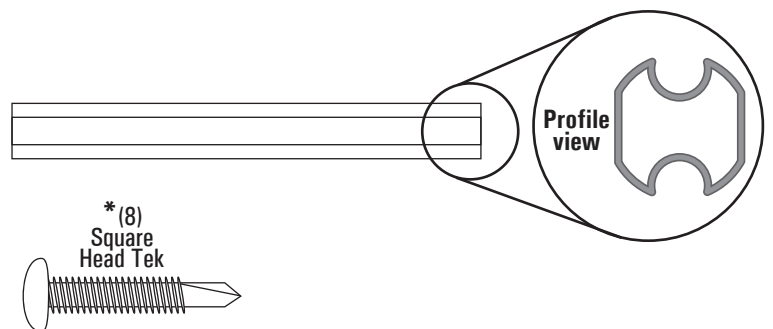

Climbing Pole for Curtain Drives

PCSR827 (14') - PCSR828 (16') -
PSCR829 (17') -
Climbing Pole 1⁵/₈" 10 Gauge

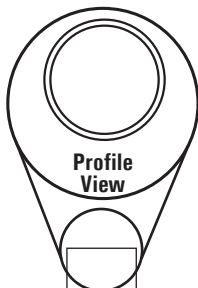

PCSR480 - Hardware Package for Climbing Pole

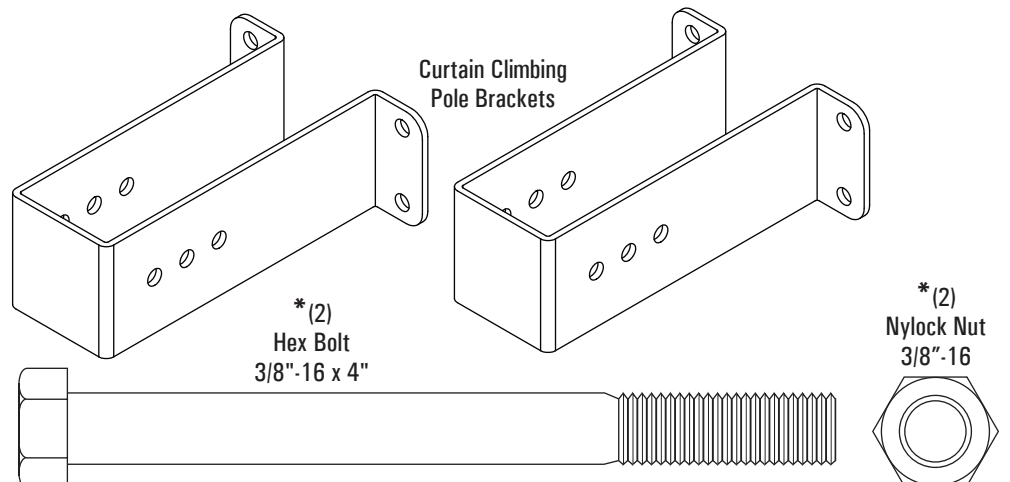

Manual Drive Components and Accessories

PCSR317 - Dual Shaft Manual Curtain Drive

WARNING!

Failure to adhere to the following instructions will void warranty and damage unit.

- Once unit is mounted in its operating position, remove and discard gearbox plug from the top side of gearbox and replace with the Hex Head Breather Bolt to allow for contraction and expansion of lubricant.
- If unit is operated by the use of a drill **ONLY use standard drill on low speed**
 - **Do NOT** use Hammerdrill or Impact Driver
 - **Do NOT** exceed 150 RPMs

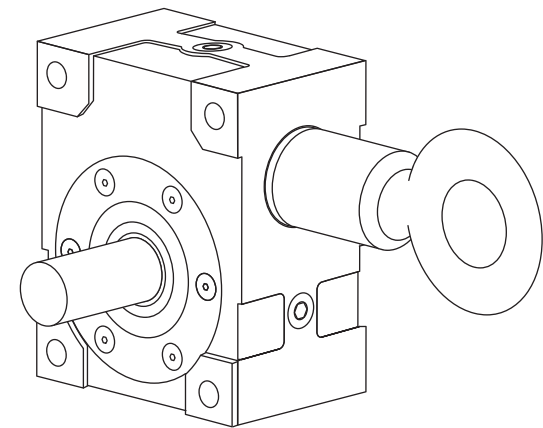

* (4)
Hex Bolt
5/16" x 3-1/2"

* (1)
Hex Head
Breather Bolt
5/16" x 1/4"

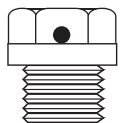

* (4)
Nylock Nut
5/16"-18

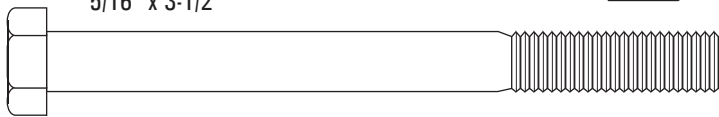
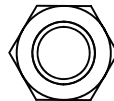

PCSR830 - Manual Drive Climbing Bracket

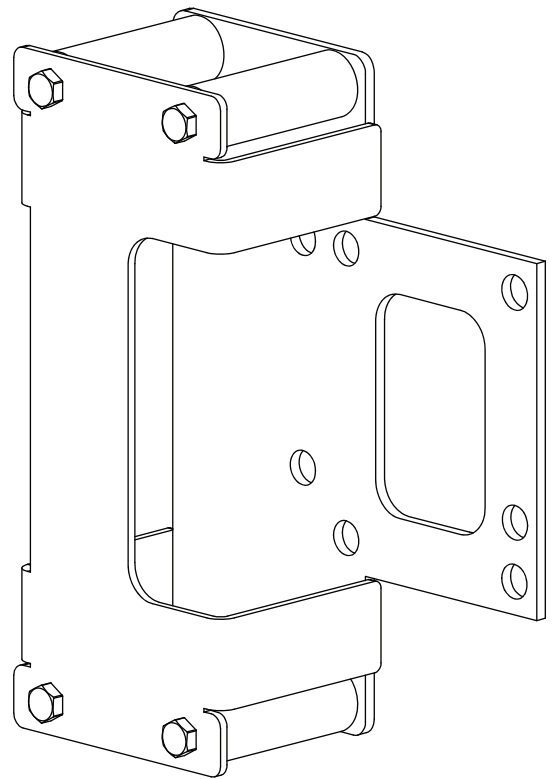

PCSR625 - Manual Curtain Drive 26MM Roll Tube Adapter

* (1)
Hex Bolt
5/16" x 2-1/2"

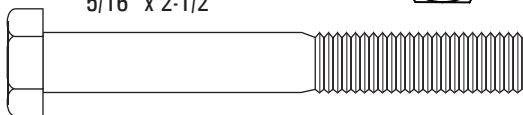

* (1)
Nylock Nut
5/16"-18



* (8)
Square Head Tek Screw
#10 x 1"

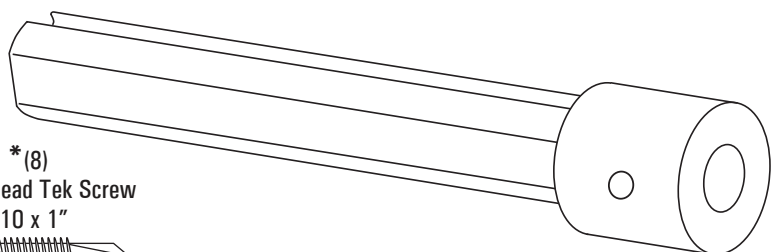

PCSR322 - 6' Shepherd's Hook or PCSR324 - 9' Shepherd's Hook



120W DC Powered Drive Components and Accessories

PCSR120W Double Shaft 120W DC Gear Box

PP10571

5' Cable Carrier

WARNING!

Failure to adhere to the following instructions will void warranty.

- PCSR120W is not weather proof. Until unit is sheltered by fully assembled and installed wind pocket **it is necessary to keep unit protected.** Damage or malfunction caused by exposure to weather will not be covered by warranty.
- Unit **must be mounted in the upright position** as shown. **Mounting unit upside down will void warranty.**
- **Do not provide power to the unit until setting limits.** **Running unit prior to setting limits can cause irreparable damage to curtain and gear box, voiding all warranties.**

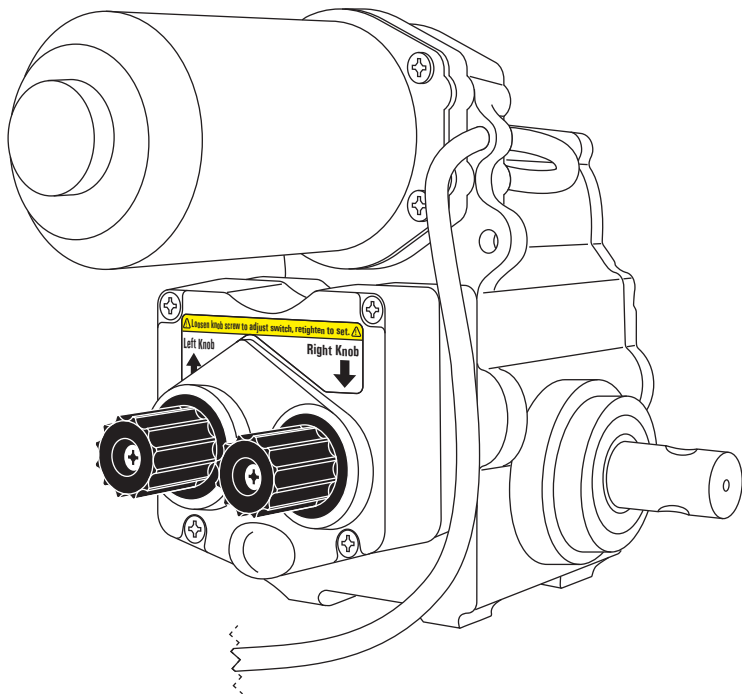

Refer to instructions included with unit for further information regarding wiring guidelines and setting limit switches.

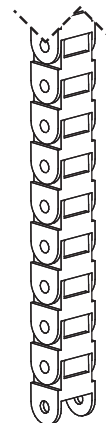
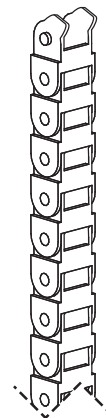

PCSR840 - Auto Drive Climbing Bracket with Hardware for PCSR120W

PCSR630 - Auto Curtain Drive 20.5MM Roll Tube Adapter

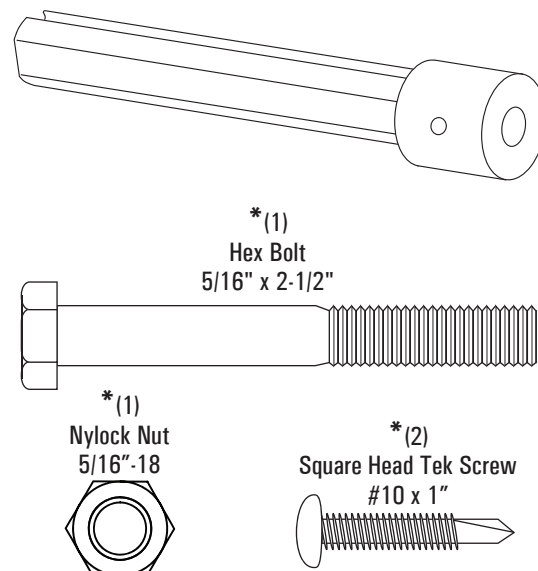
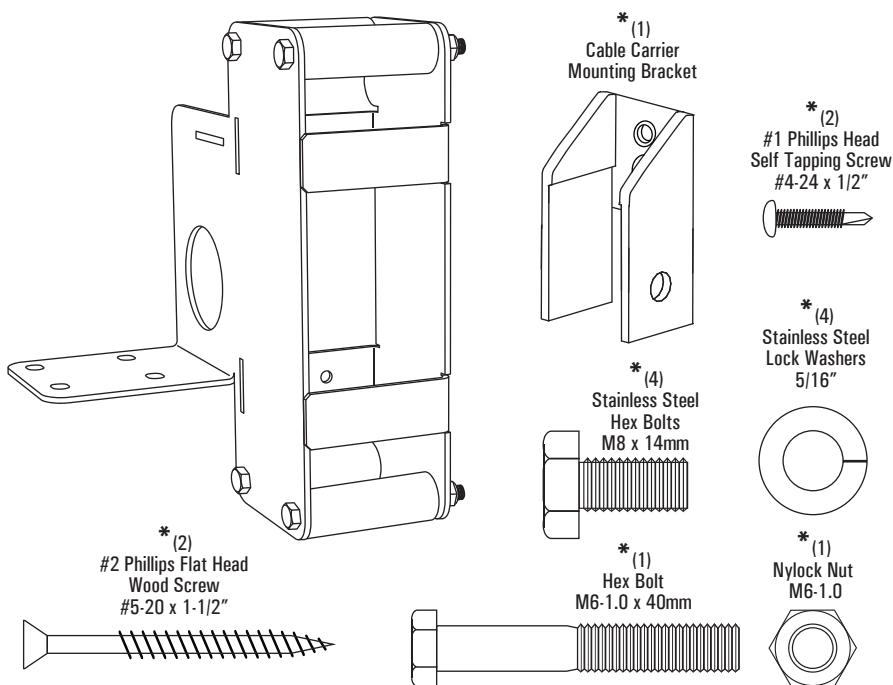

250W DC Powered Drive Components and Accessories

PCSR250W Double Shaft 250W DC Gear Box

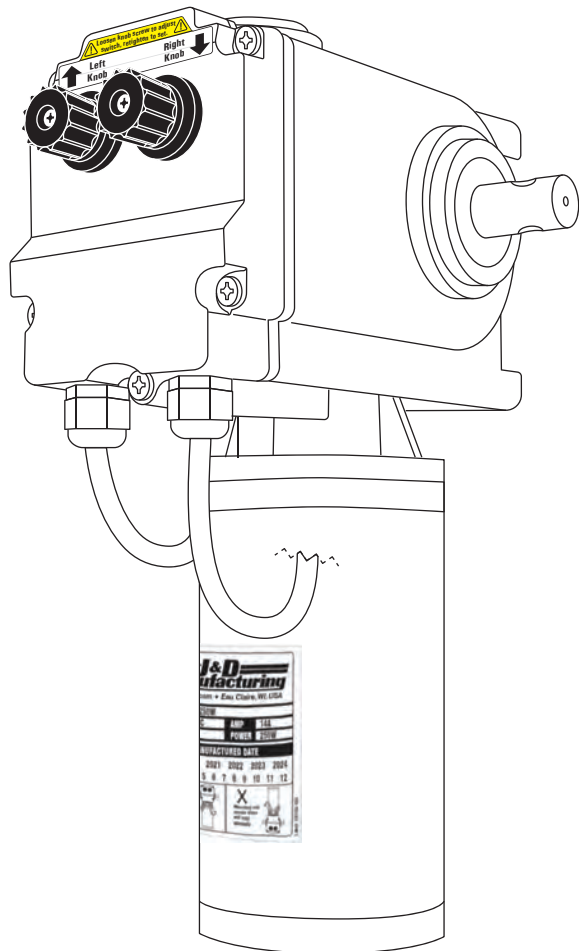

WARNING!

Failure to adhere to the following instructions will void warranty.

- PCSR250W is not weather proof. Until unit is sheltered by fully assembled and installed wind pocket **it is necessary to keep unit protected.** Damage or malfunction caused by exposure to weather will not be covered by warranty.
- Unit **must be mounted in the upright position** as shown. **Mounting unit upside down will void warranty.**
- **Do not provide power to the unit until setting limits.** **Running unit prior to setting limits can cause irreparable damage to curtain and gear box, voiding all warranties.**

Refer to instructions included with unit for further information regarding wiring guidelines and setting limit switches.

PP10571

5' Cable Carrier



PCSR845 - Auto Drive Climbing Bracket with Hardware

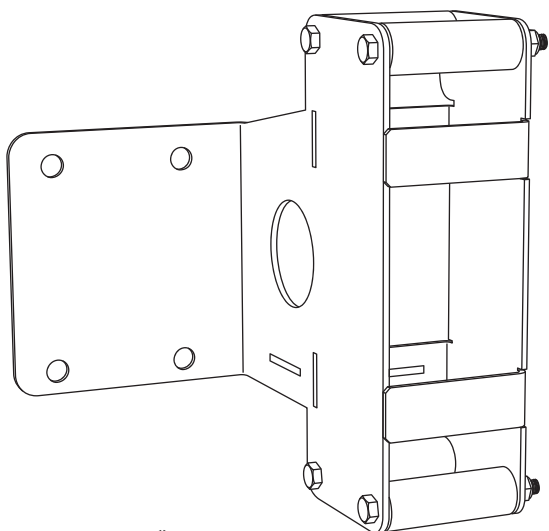

- * (1) Cable Carrier Mounting Bracket
- * (2) #1 Phillips Head Self Tapping Screw #4-24 x 1/2"

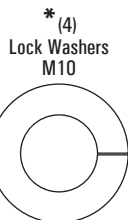

- * (4) Lock Washers M10

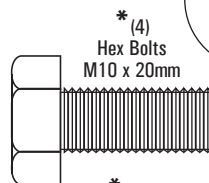

- * (4) Hex Bolts M10 x 20mm

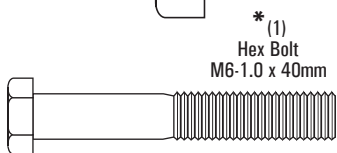

- * (1) Hex Bolt M6-1.0 x 40mm



- * (1) Nylock Nut M6-1.0

- * (2) #2 Phillips Flat Head Wood Screw #5-20 x 1-1/2"

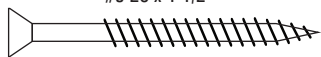

PCSR635 - Auto Curtain Drive 22.5MM Roll Tube Adapter

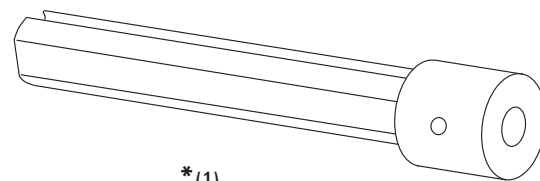

- * (1) Hex Bolt 3/8" x 2-1/2"

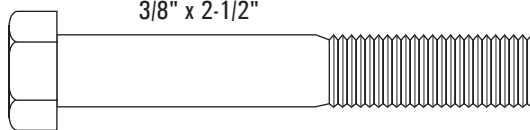

- * (1) Nylock Nut 3/8"-16

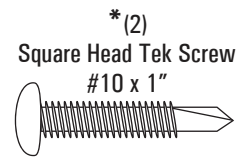

- * (2) Square Head Tek Screw #10 x 1"

Square & Round Wind Pipe Systems

PCSR930 (14') - PCSR931 (16') - 12 Gauge, 1 1/2" Square, Galvanized Wind Pipe

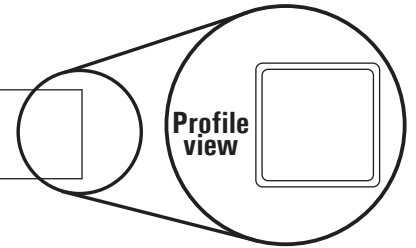

PCSR914 (14') - PCSR915 (16') - 18 Gauge, 1 5/8" Round, Galvanized Wind Pipe

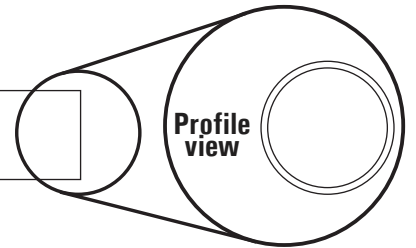

PCSR910-P (SET)

Outside Mount Round/Square/Rectangular Adjustable Wind Pipe Brackets

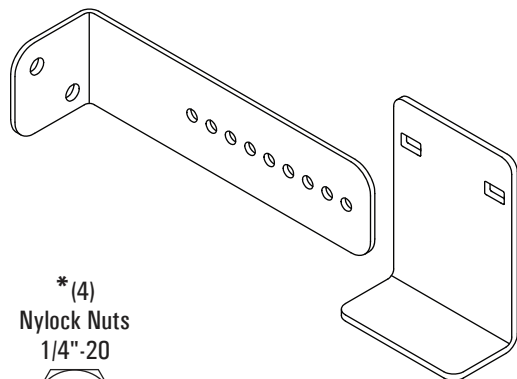
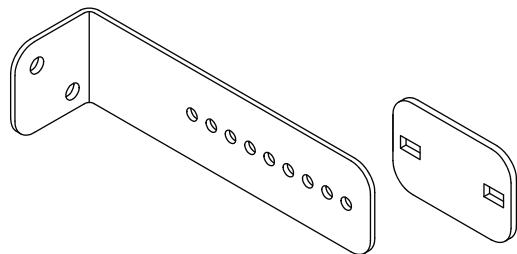

* (4)
Nylock Nuts
1/4"-20



* (4)
Carriage Bolts
1/4"-20 x 2-1/2"

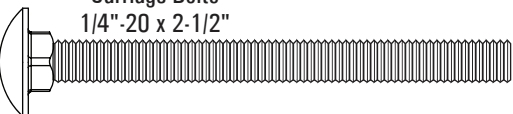

PCSR940 (SET)

Outside Mount Round/Square Bracket

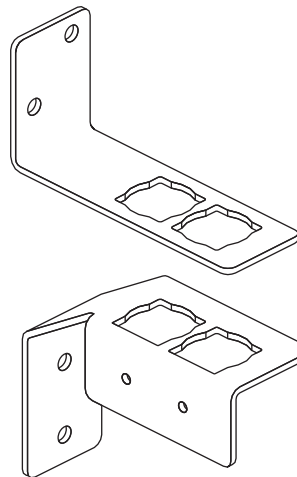

* (1)
Hex Head Tek Screw
1/4"-14 x 1-1/4"

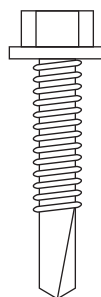

PCSR942 (SET)

Inside Mount Round/Square Bracket

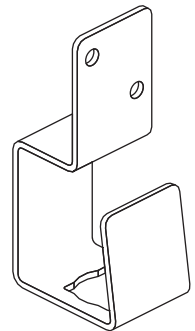

* (1)
Hex Head Tek Screw
1/4"-14 x 1-1/4"

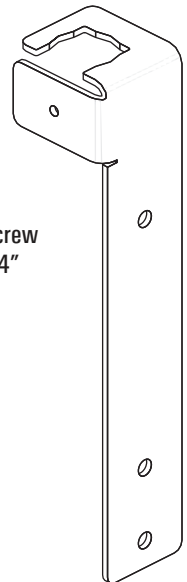
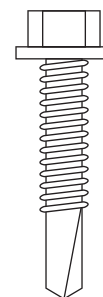

Rectangle Wind Pipe System with Cushion

PCSR917 (12') - PCSR918 (14') - PCSR919 (16') - 1" x 1-1/2" Rectangular Wind Pipe

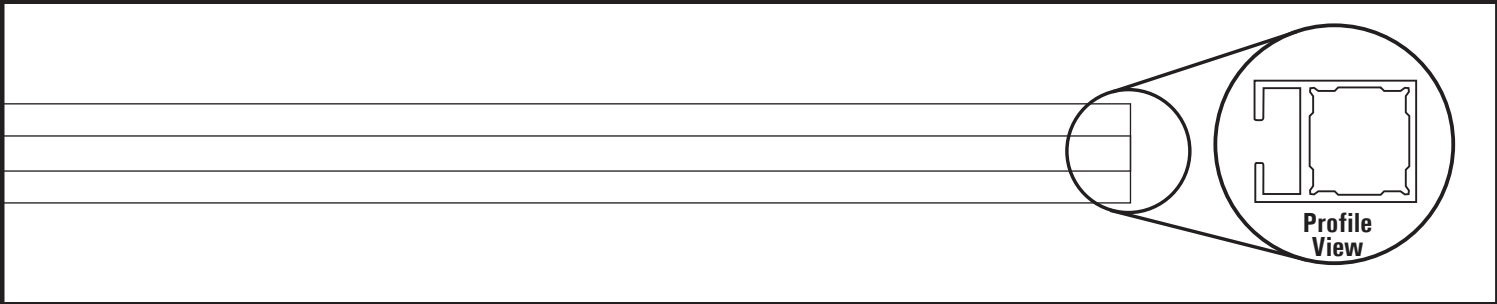

PP10381 - Rubber Cushion, 100' Roll



PCSR910-P (SET)
Outside Mount Round/Square/Rectangular Adjustable Wind Pipe Brackets

PCSR941 (SET)
Outside Mount Rectangular Bracket

PCSR943 (SET)
Inside Mount Rectangular Bracket

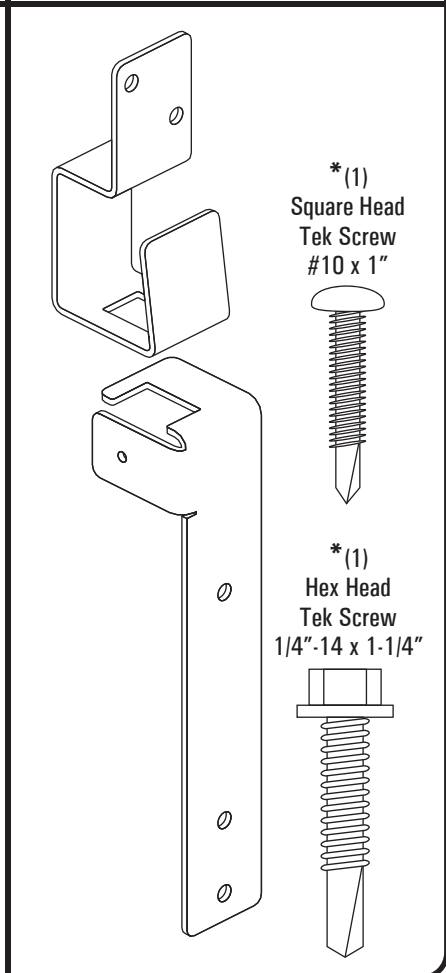
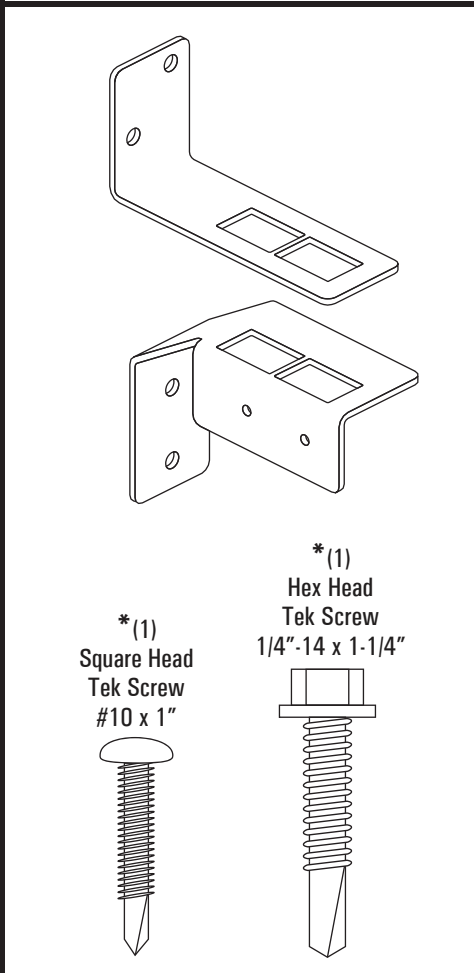
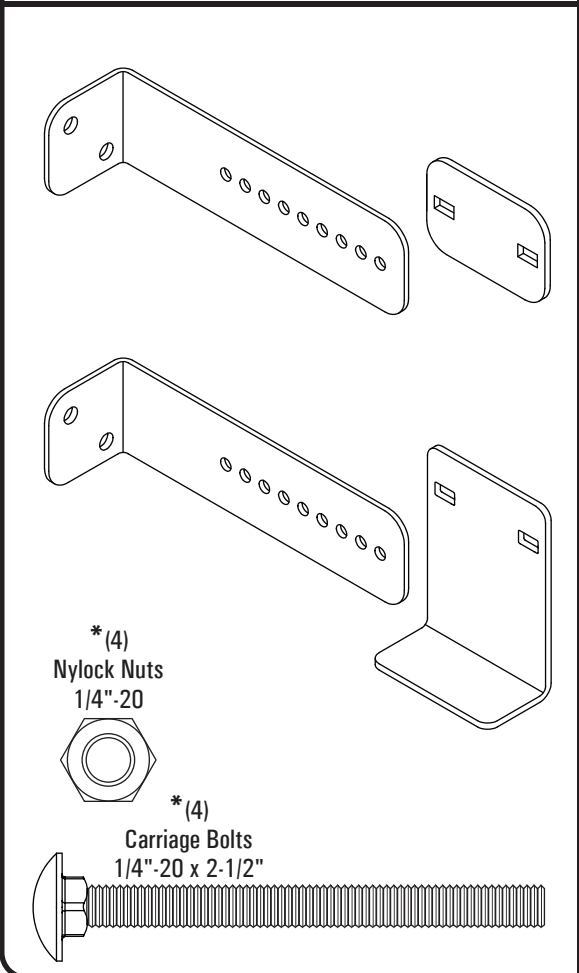

Wind Strap System

PCSR925 - Curtain Wind Strap Webbing, 1 7/8" Wide, 600' Roll

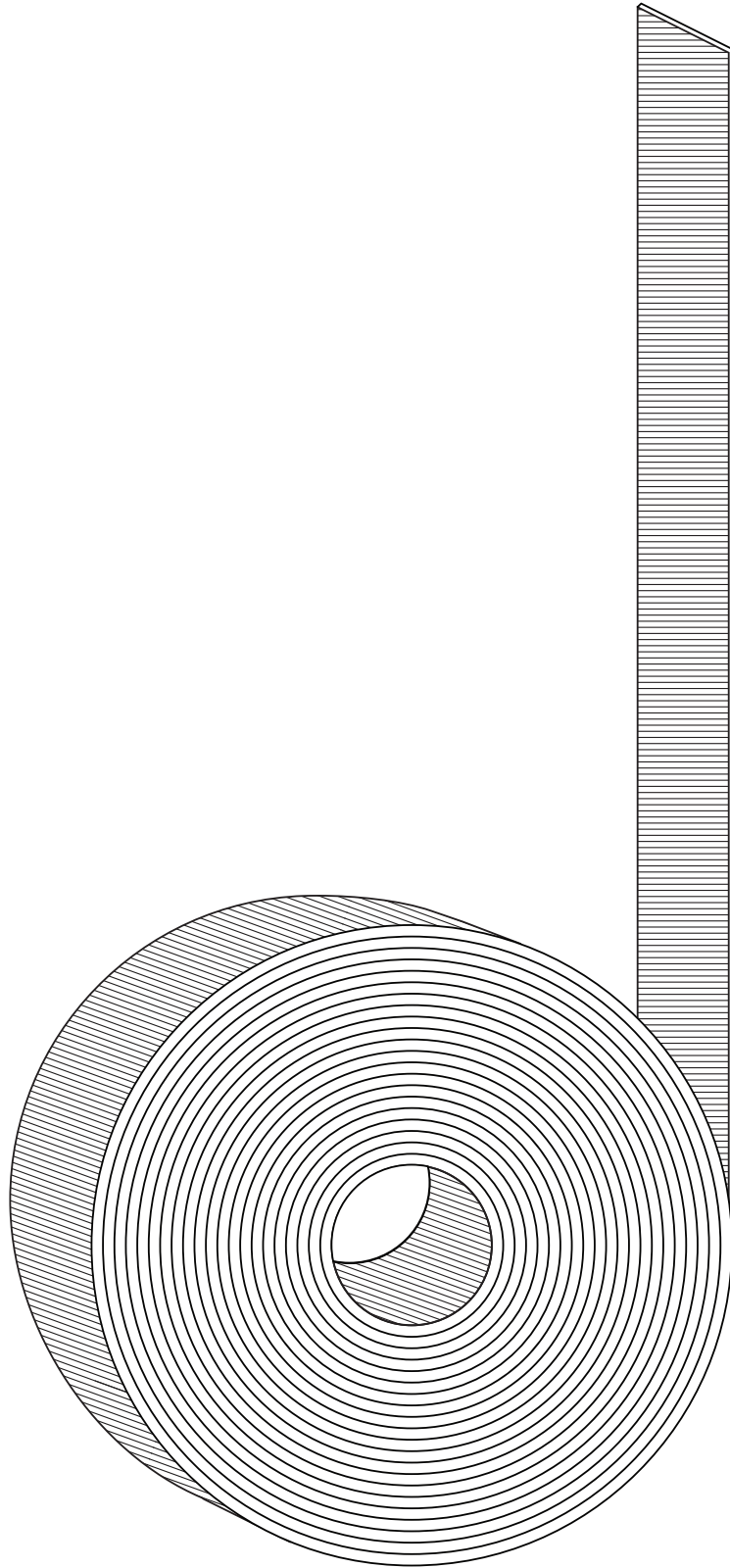

PCSR927 - Curtain Wind Strap Top Bracket

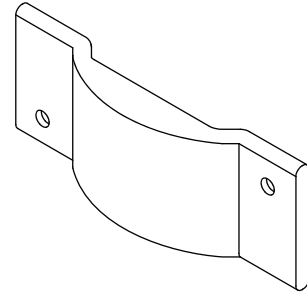

PCSR929 - Poly Wind Strap Protector

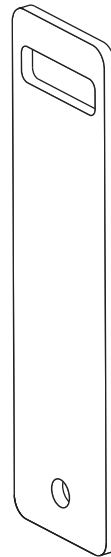

PCSR935 - Curtain Wind Strap Winch

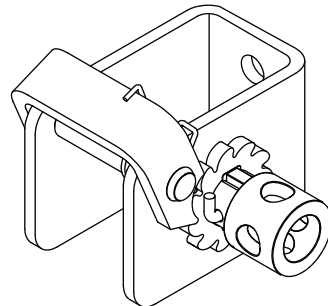

4'-12' PCSR975 - End Drive Wind Pocket Kits

Dead End Curtain Wind Pocket

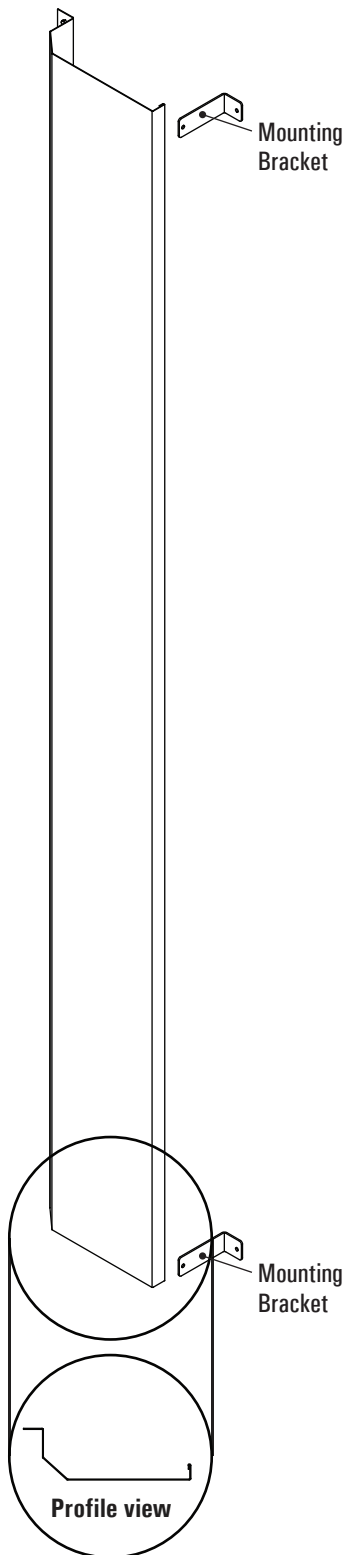

End Drive Curtain Wind Pocket Door

(open/closed side pieces are interchangeable)

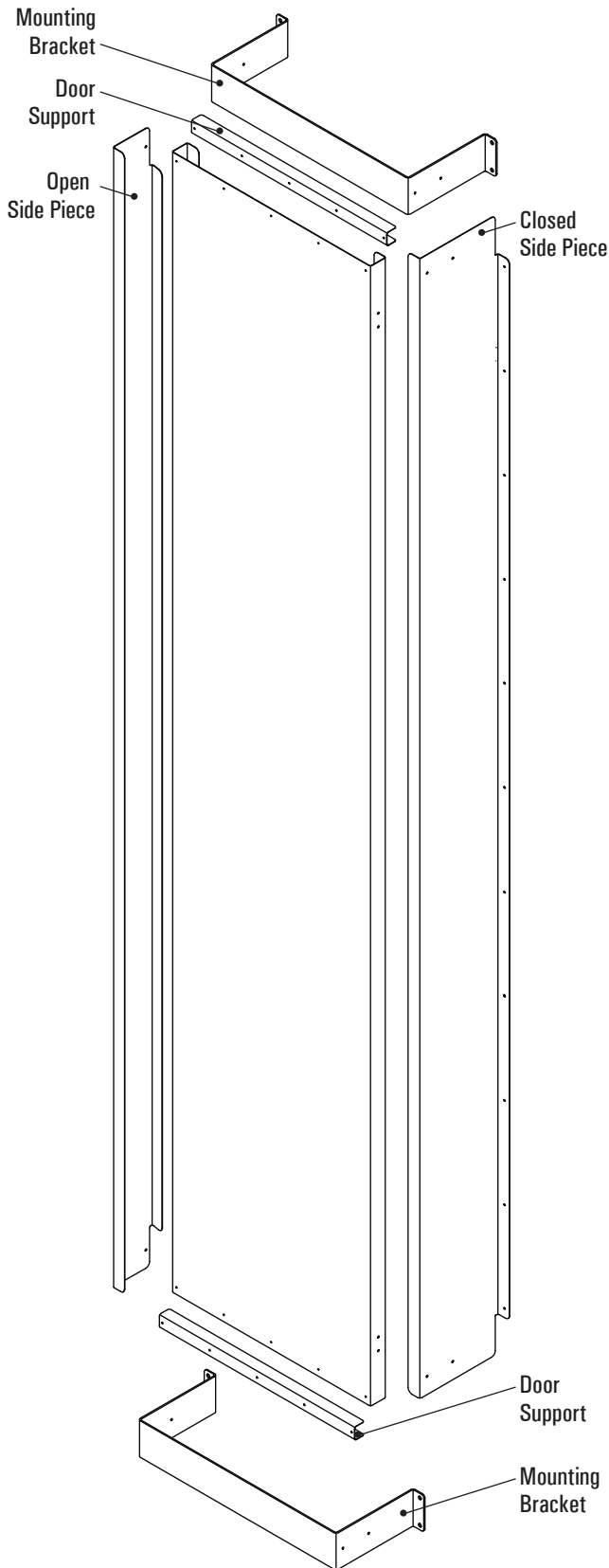

End Drive Door Hinges, Latch & Hardware

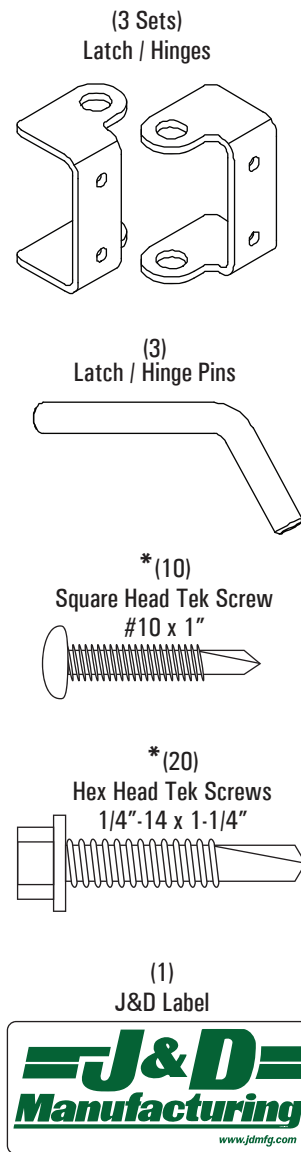

Dead End Hardware

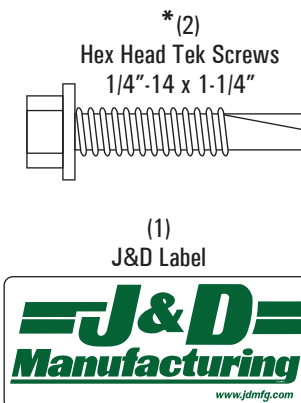

13'-18' PCSR975 - End Drive Wind Pocket Kits



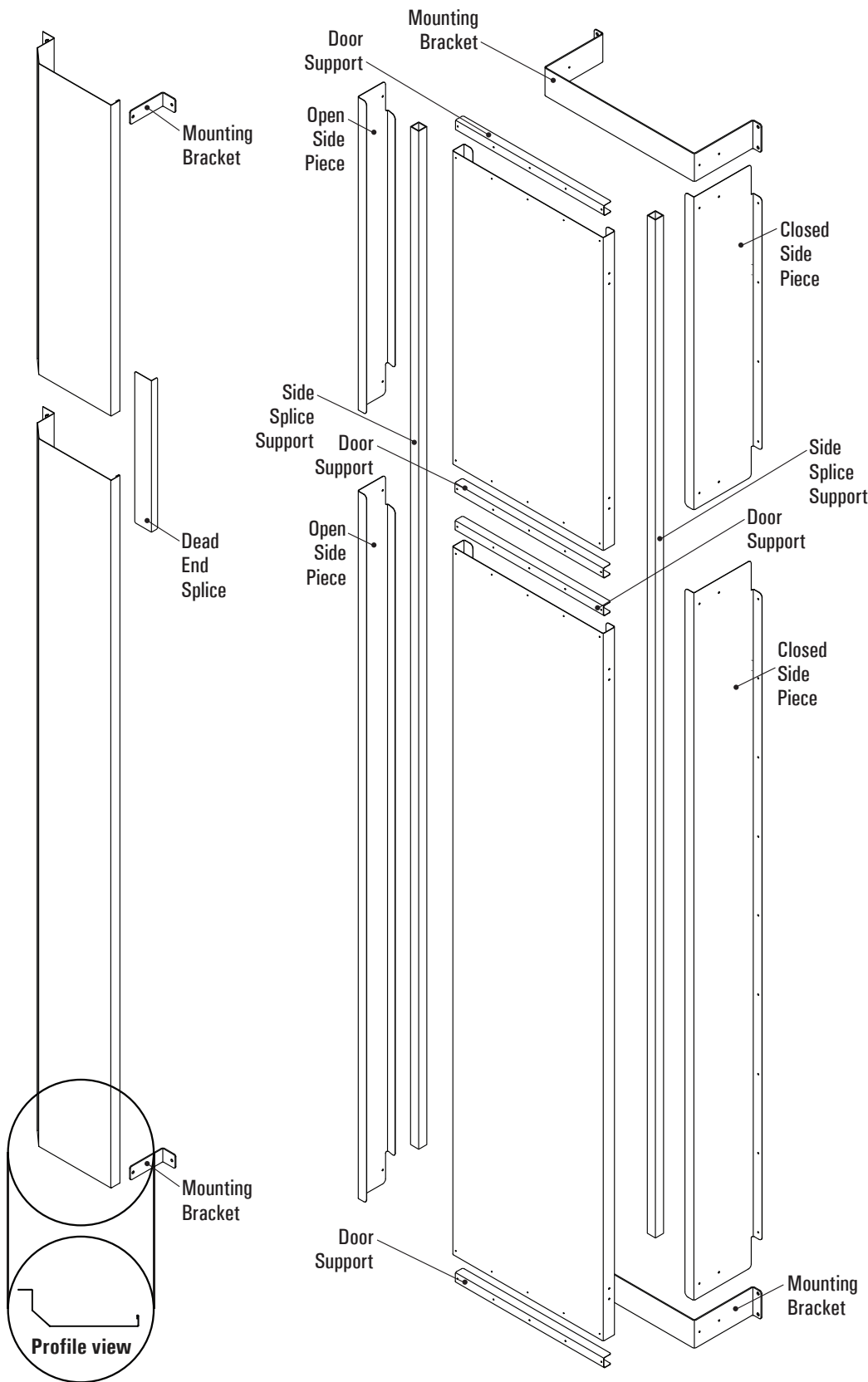

Dead End Curtain Wind Pocket

End Drive Curtain Wind Pocket Door

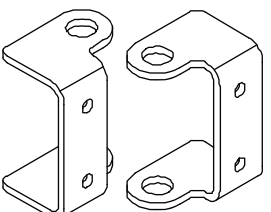
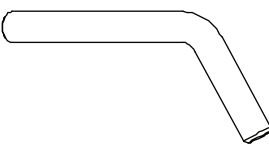

(open/closed side pieces are interchangeable)

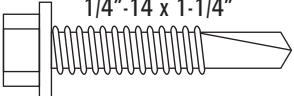

End Drive Door Hinges, Latch & Hardware

- (6 Sets)
Latch / Hinges

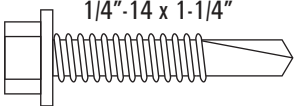
- (6)
Latch / Hinge Pins

- *(51-54)
Square Head Tek Screw
#10 x 1"

- *(48)
Hex Head Tek Screws
1/4"-14 x 1-1/4"

- (1)
J&D Label

Dead End Hardware

- *(2)
Hex Head Tek Screws
1/4"-14 x 1-1/4"

- (1)
J&D Label

4'-12' PCSR976 - Center Drive Wind Pocket Kits

Dead End
Curtain Wind Pocket

Center Drive Curtain
Wind Pocket Door

Dead End
Curtain Wind Pocket

**Center Drive Door Hinges,
Latch & Hardware**

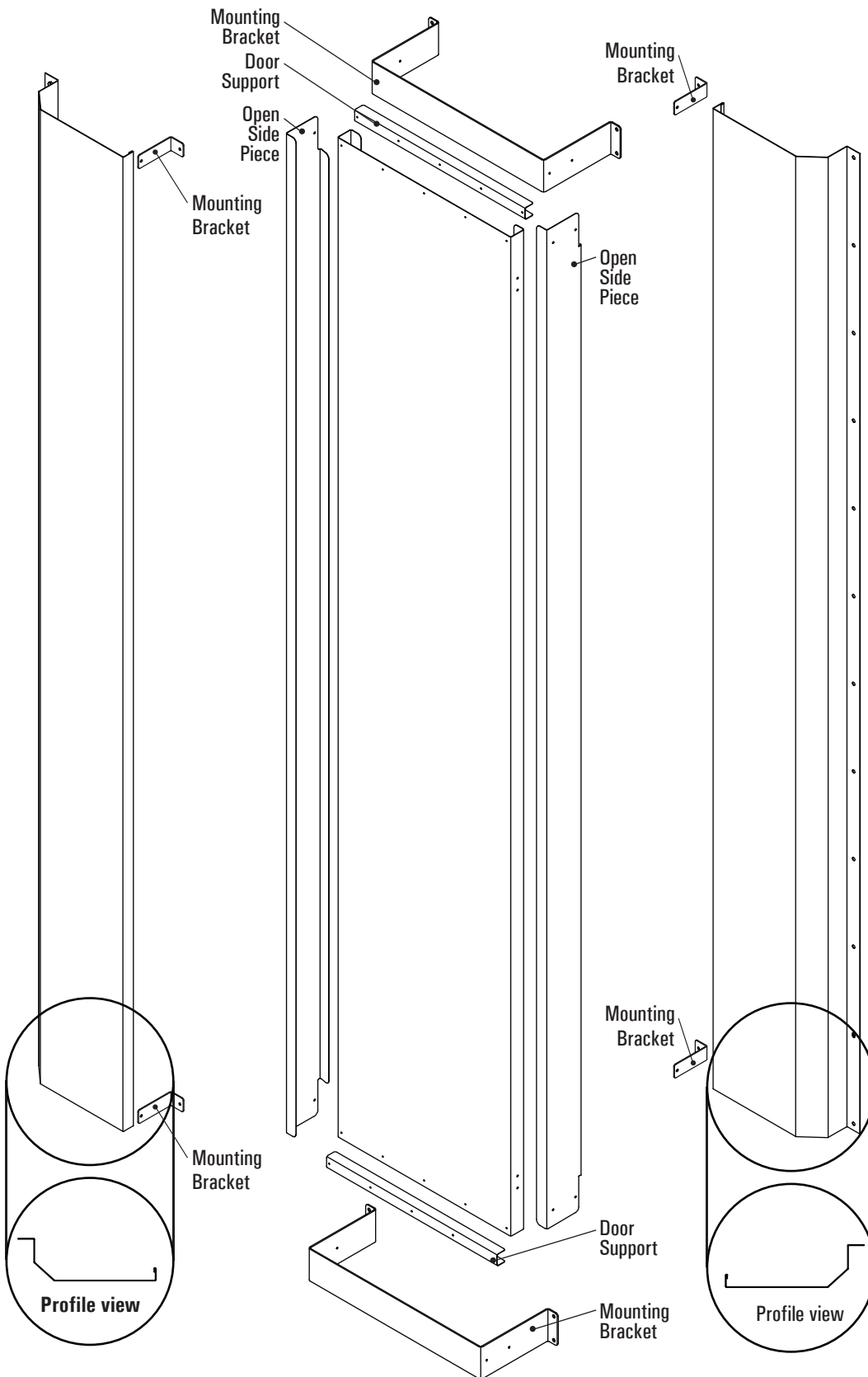

(3 Sets)
Latch / Hinges

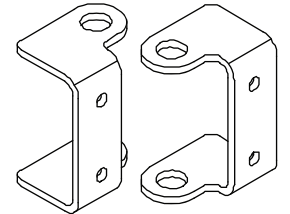

(3)
Latch / Hinge Pins

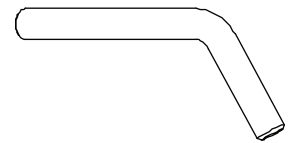

*(10)
Square Head Tek Screw
#10 x 1"



*(20)
Hex Head Tek Screws
1/4"-14 x 1-1/4"

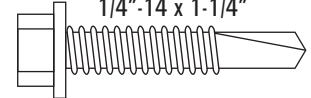

(1)
J&D Label



Dead End Hardware

*(4)
Hex Head Tek Screws
1/4"-14 x 1-1/4"

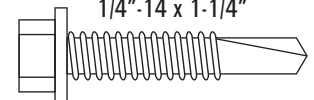

(2)
J&D Label



13'-18' PCSR976 - Center Drive Wind Pocket Kits

Dead End Curtain Wind Pocket

Center Drive Curtain Wind Pocket Door

Dead End Curtain Wind Pocket

Center Drive Door Hinges, Latch & Hardware

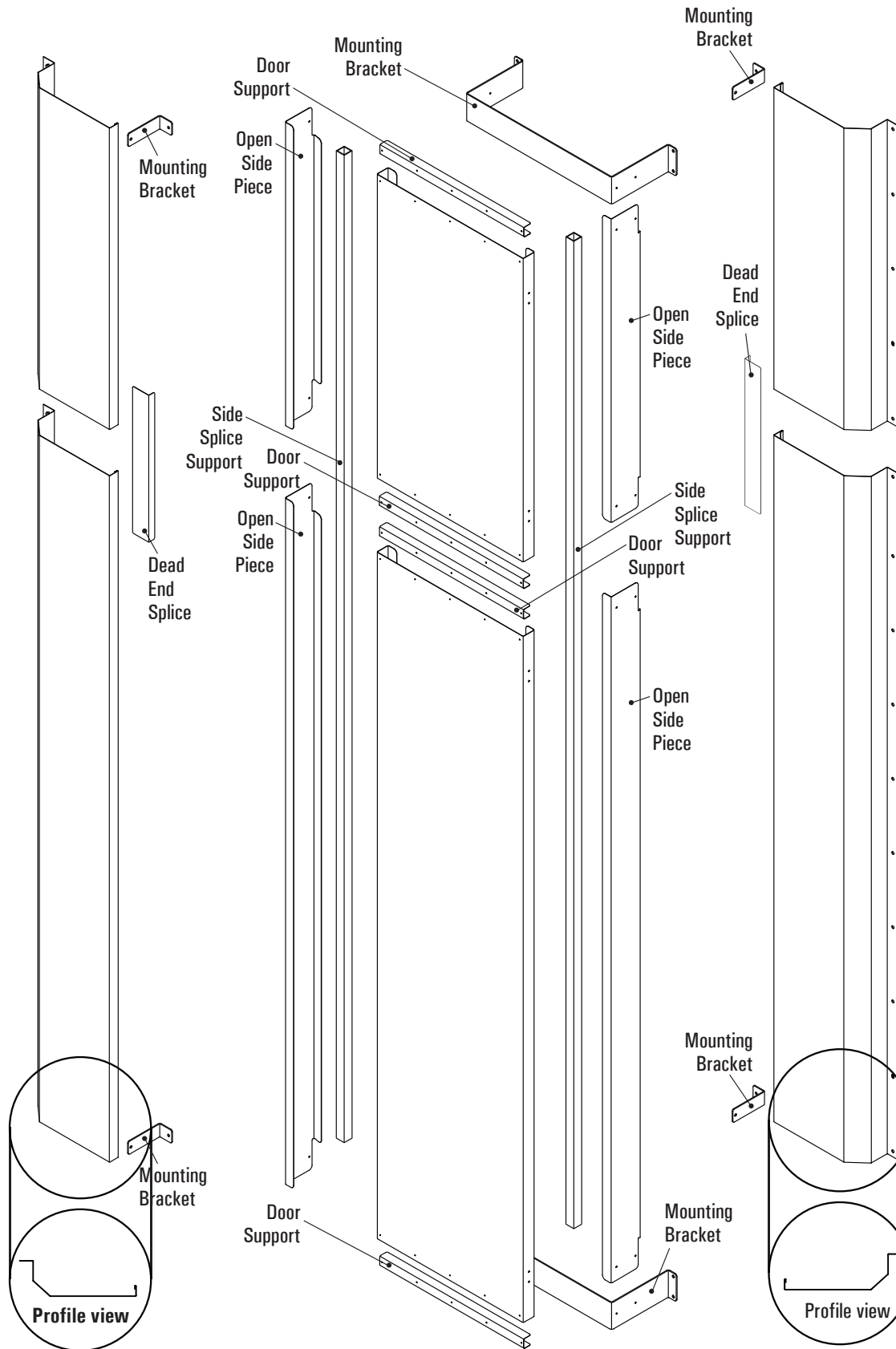

(6 Sets)
Latch / Hinges

(6)
Latch / Hinge Pins

*(52-54)
Square Head Tek Screw
#10 x 1"

*(48)
Hex Head Tek Screws
1/4"-14 x 1-1/4"

(1)
J&D Label

Dead End Hardware

*(4)
Hex Head Tek Screws
1/4"-14 x 1-1/4"

(2)
J&D Label

End Drive Wind Pocket Backer Panels

PCSR974 - 4'-12' End Drive

PCSR974 - 13'-18' End Drive

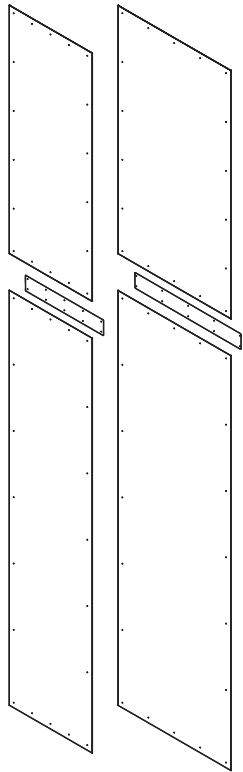
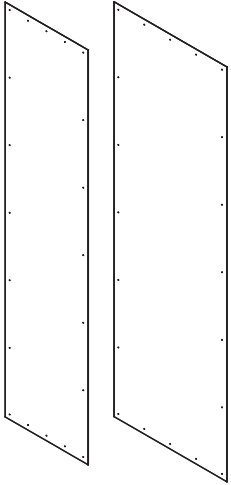

*(12)
Hex Head
Tek Screws
1/4"-14 x 1-1/4"

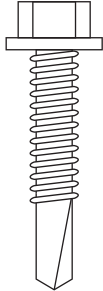

Wind Pocket Top Cover

PCSR978 - Drive Wind Pocket Cover

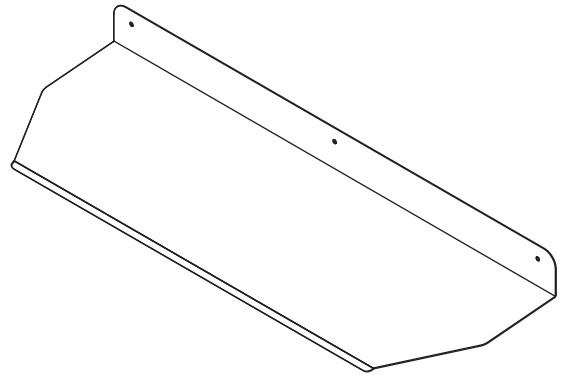

Center Drive Wind Pocket Backer Panels

PCSR977 - 4'-12' Center Drive

PCSR977 - 13'-18' Center Drive

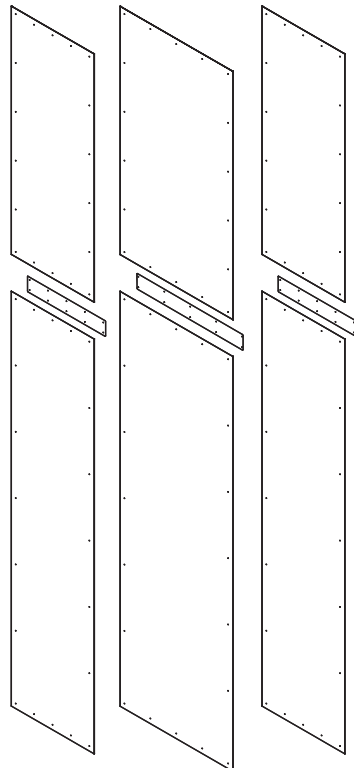
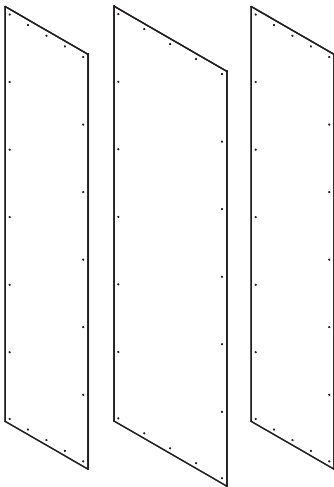

*(18)
Hex Head
Tek Screws
1/4"-14 x 1-1/4"

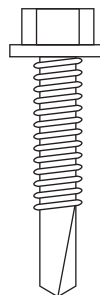

If system does not use back panels proceed to [Section G](#) for Center Drive Installation or to [Section H](#) for End Drive Inst.

Identify the dead end panel/s from the center/end drive panel and then the front from the back on all the back panels. The back of the panels has the overlapping rolled hem edge.

C1

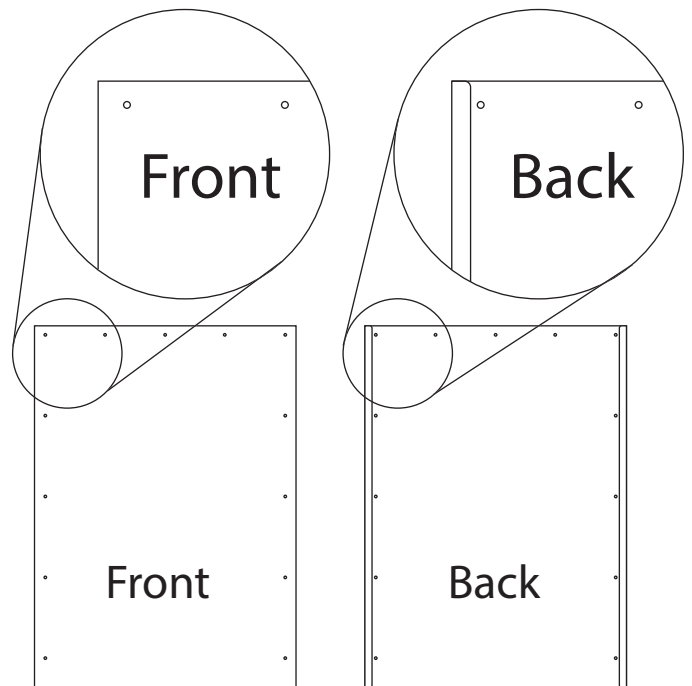
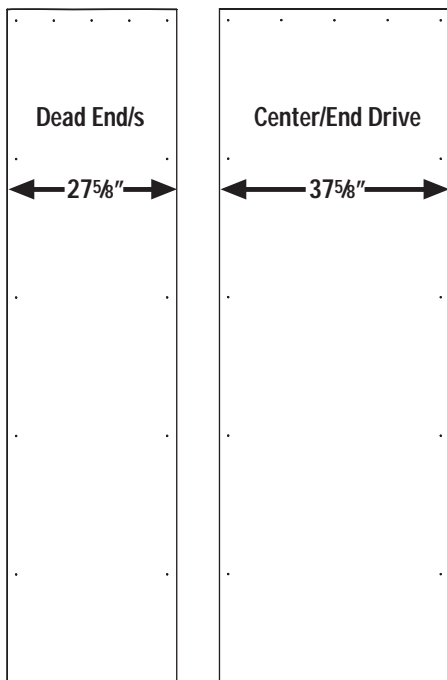

Sets of back panels over 12' require splicing. Align the pre-punched splice holes and panel holes as shown below making sure that the splice piece is on the back side of the panels. Secure panels and splice from the front side of the panels using (6) 1/4"-14 x 1-1/4" Hex Head Tek Screws (provided with spliced panels) as shown below, do not use edge holes at this time.

C2

*(6 per splice)
Hex Head
Tek Screws
1/4"-14 x 1-1/4"

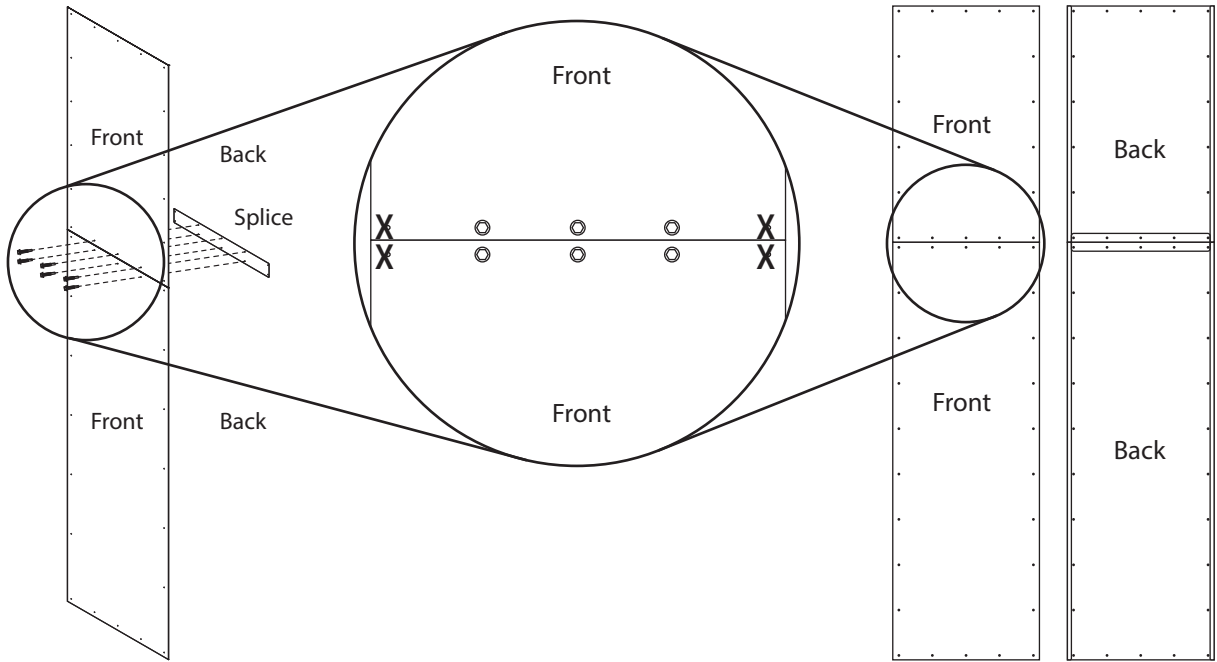
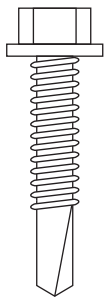

If system is Center Drive proceed to [Section G](#).

If system is End Drive proceed to [Section H](#).

Measure and mark the center of the opening or the alternate predetermined location of where center drive is intended to be installed.

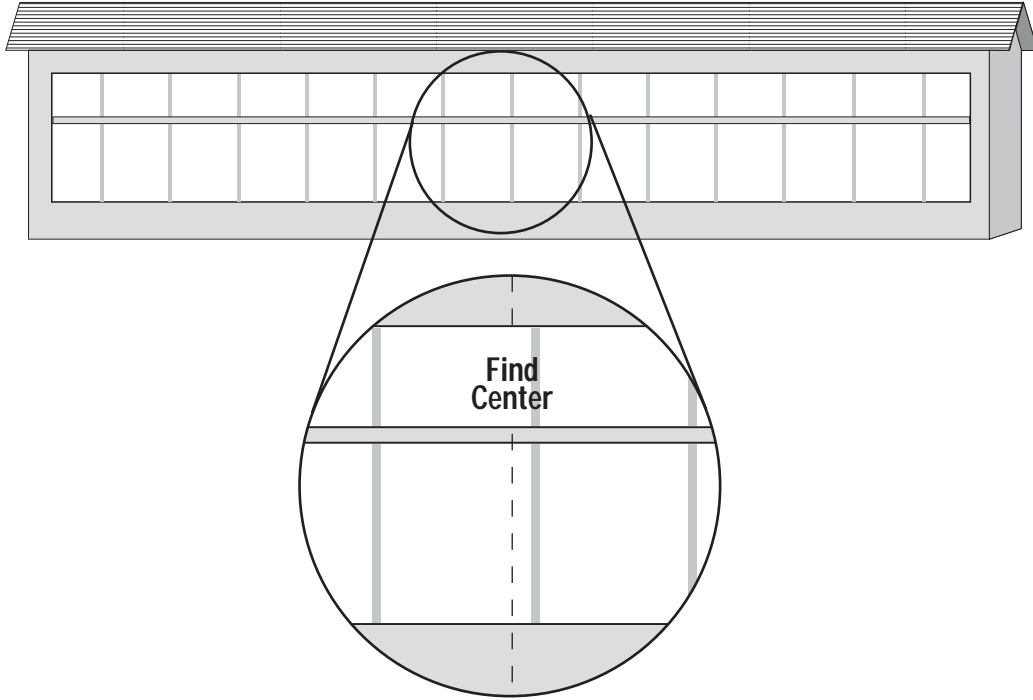

D1

Center center drive back panel vertically then align center of panel with line made in **Step D1** as shown. Using fasteners specific to your building type (refer to **Section B - Page #1** for hardware installation specifications) secure all the top and bottom panel edges that overlap building using panel pre-punched holes as your guide to placement and quantity of hardware required.

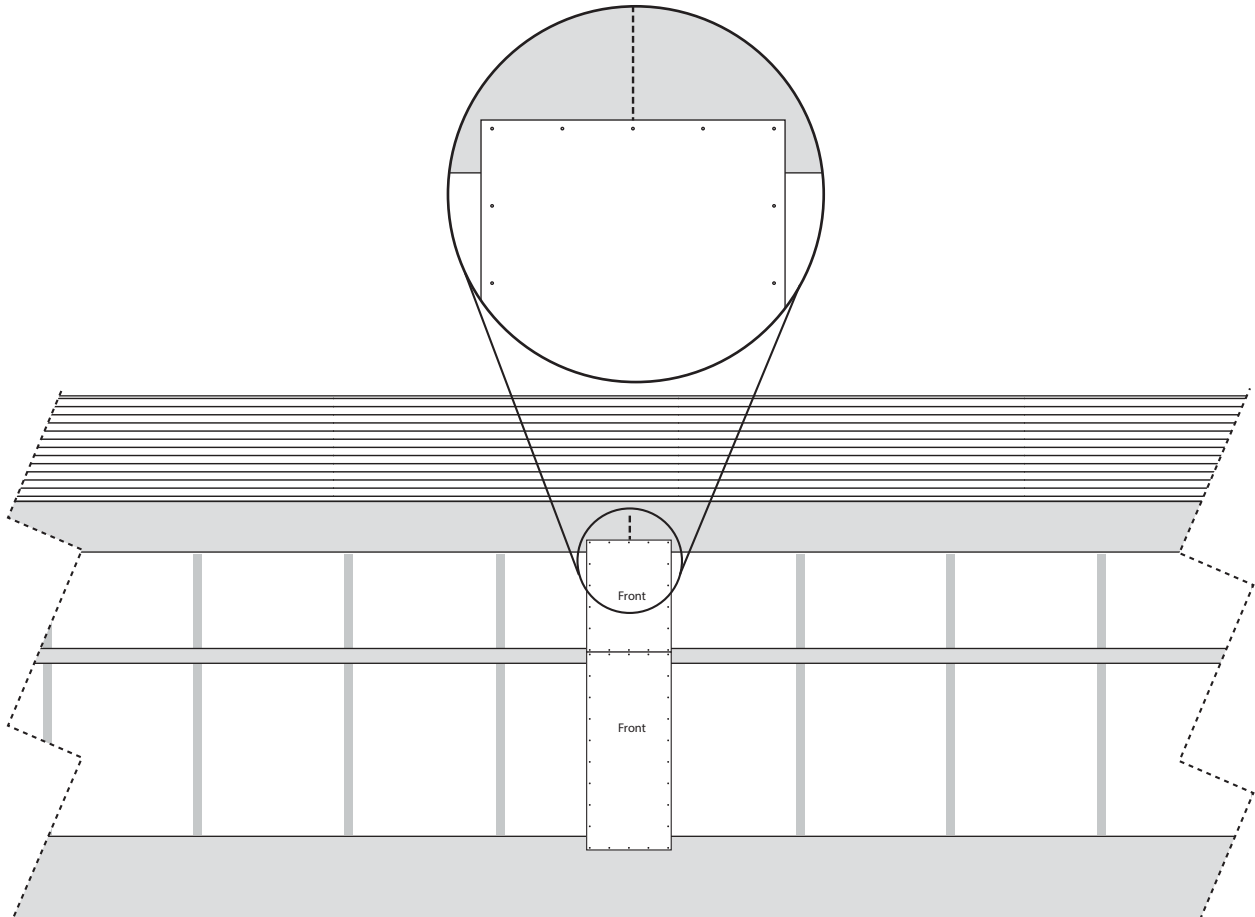

D2

At both ends of curtain opening measure 3" from edge of opening and mark entire height of opening with a vertical line

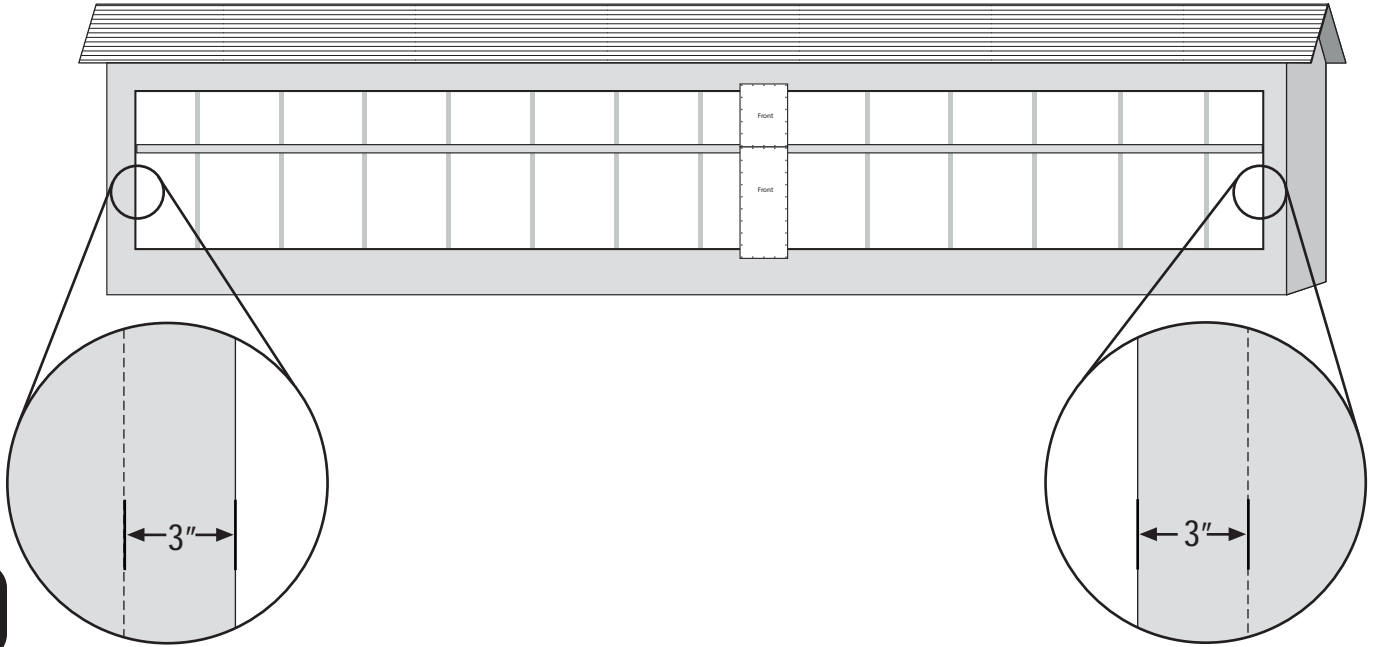

D3

Center back panels vertically then align edge of dead end back panels with lines made in **Step D3** as shown. Using fasteners specific to your building type (refer to **Section B - Page #1** for hardware installation specifications) secure all 3 panel edges that overlap building using panel pre-punched holes as your guide to placement and quantity of hardware required.

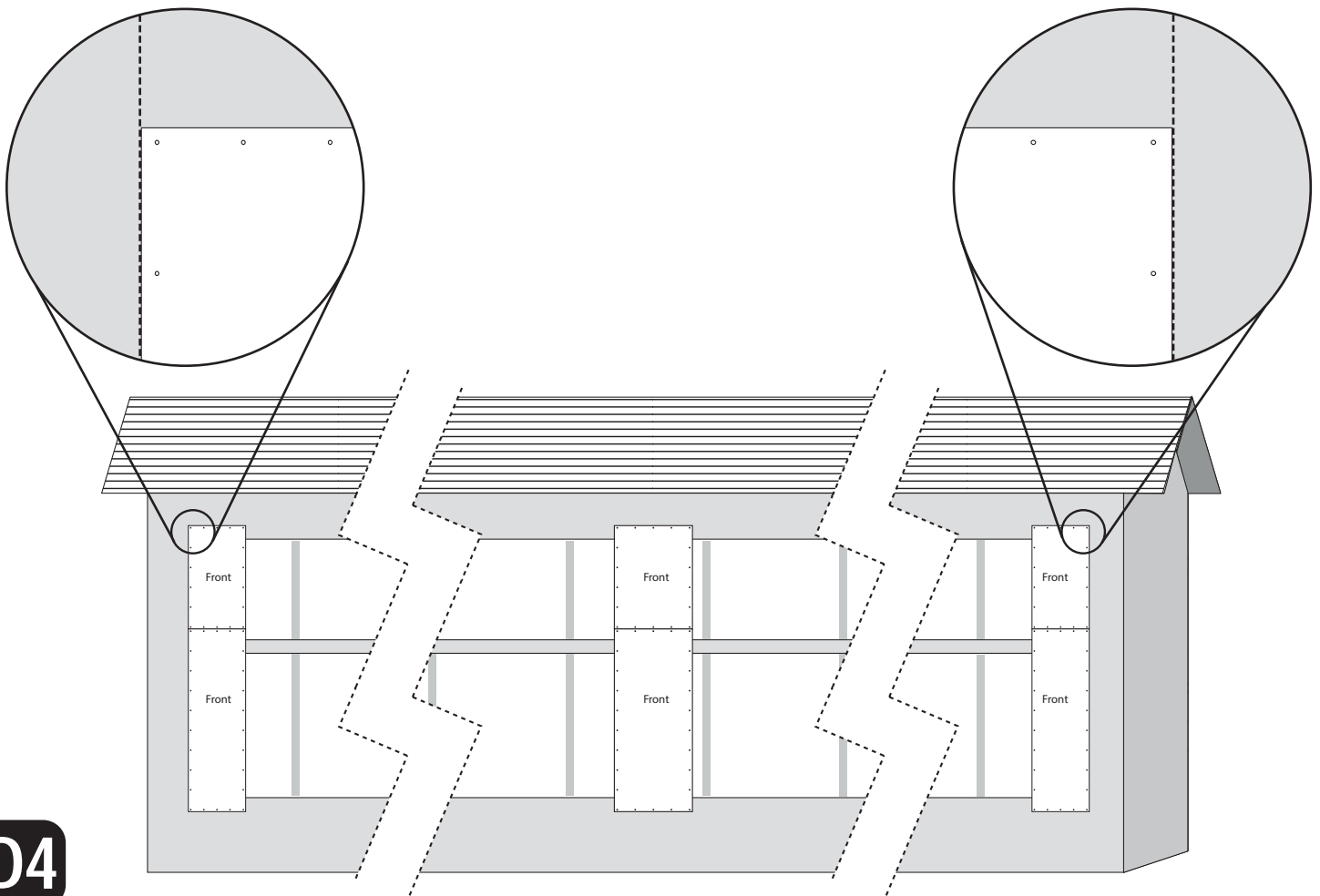

D4

Using pre-punched screw holes on the unsecured edges of the back panels as your guide install interior anchored supports (i.e. vertical stud - not included) centered over screw holes. Once supports are installed, from the exterior secure the edges of back panels to the supports.

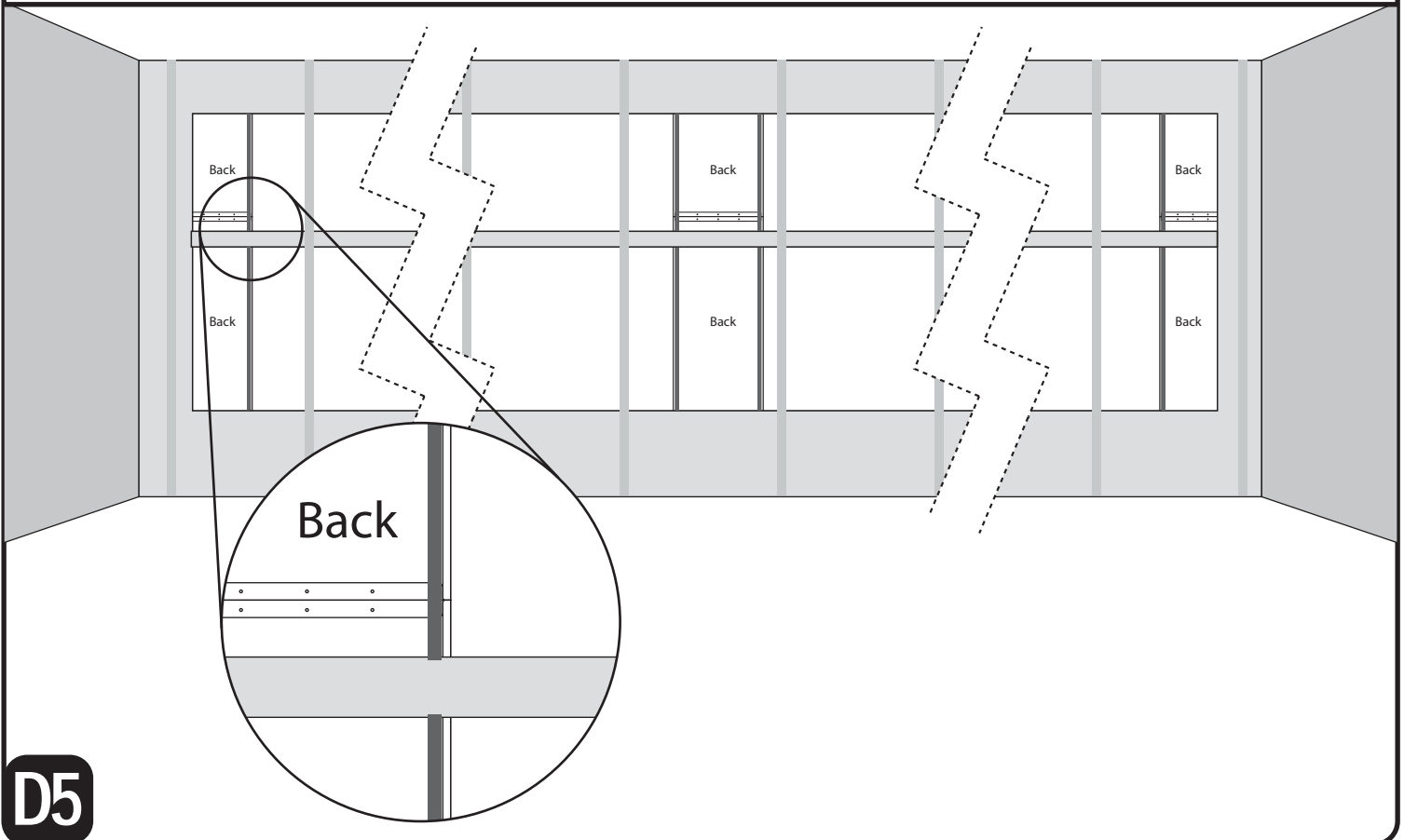
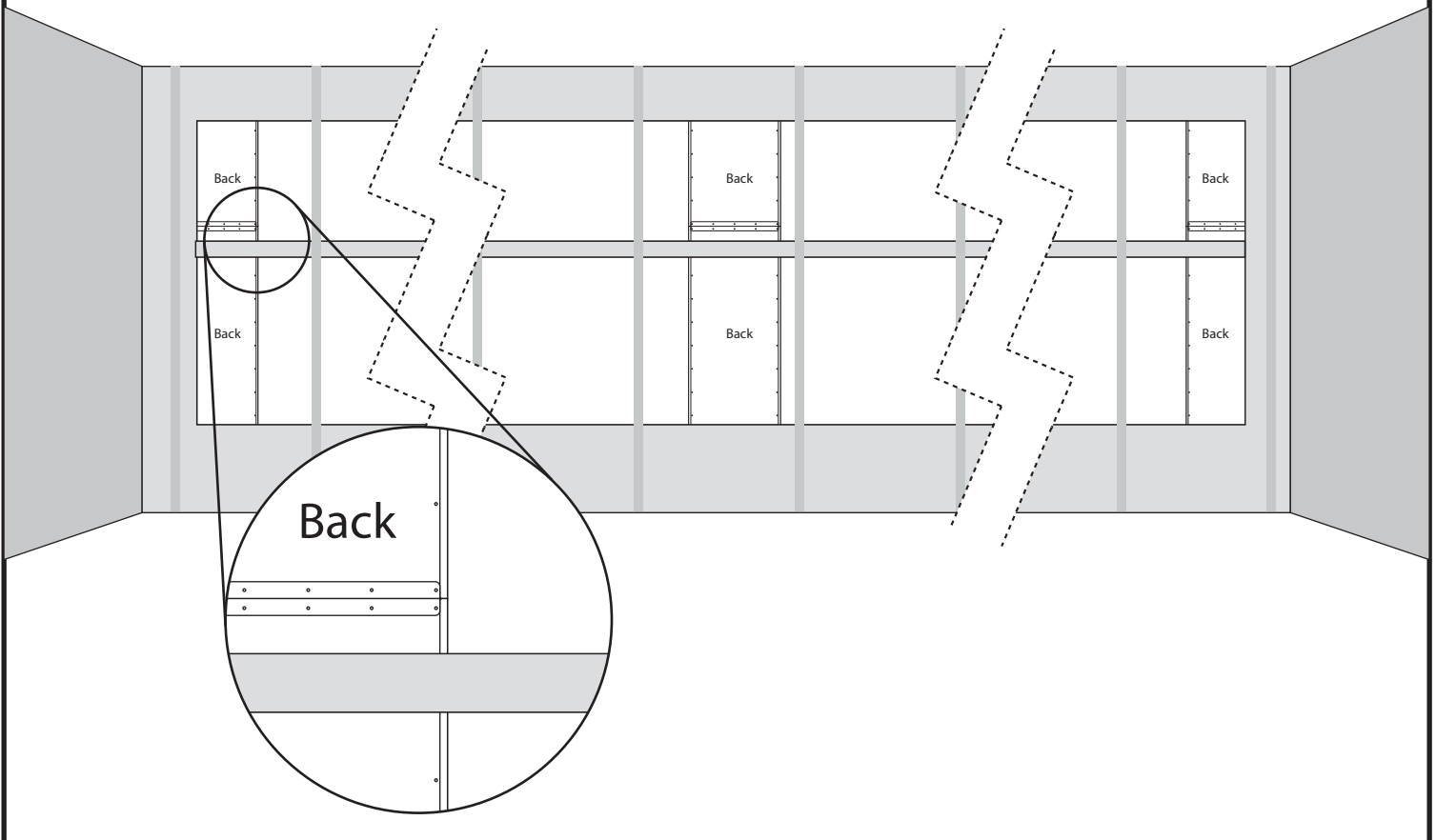

If using interior wind pipes , proceed to Section F.

Measure and mark 1" above the curtain opening. Using a chalk line mark a straight line across the full length of the curtain opening and entire width of the back panels. If installing a two tier system, use the same procedure for the top of the second curtain tier.

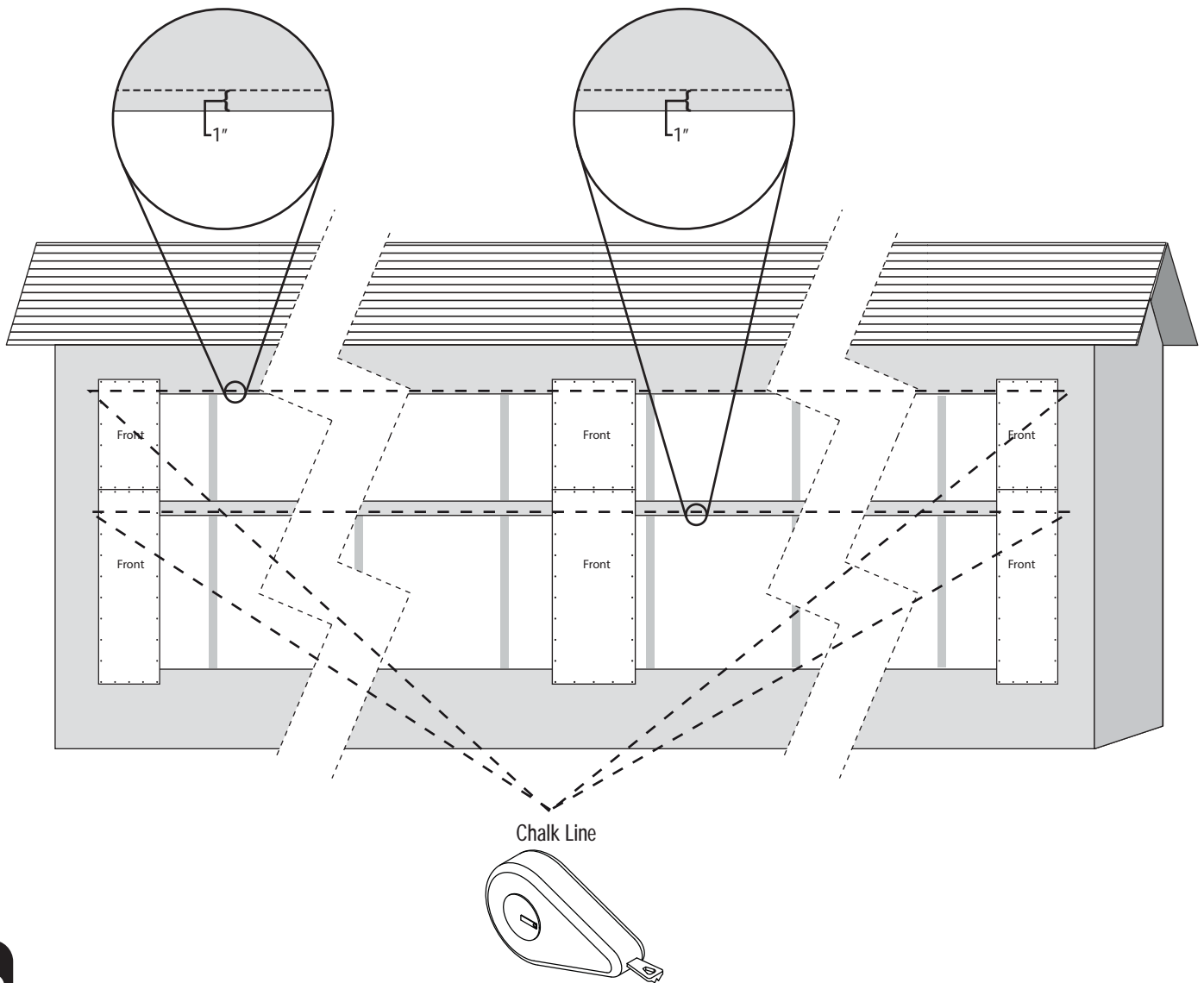

D6

At both ends of curtain opening measure 3" from edge of opening and mark entire height of opening with a vertical line.

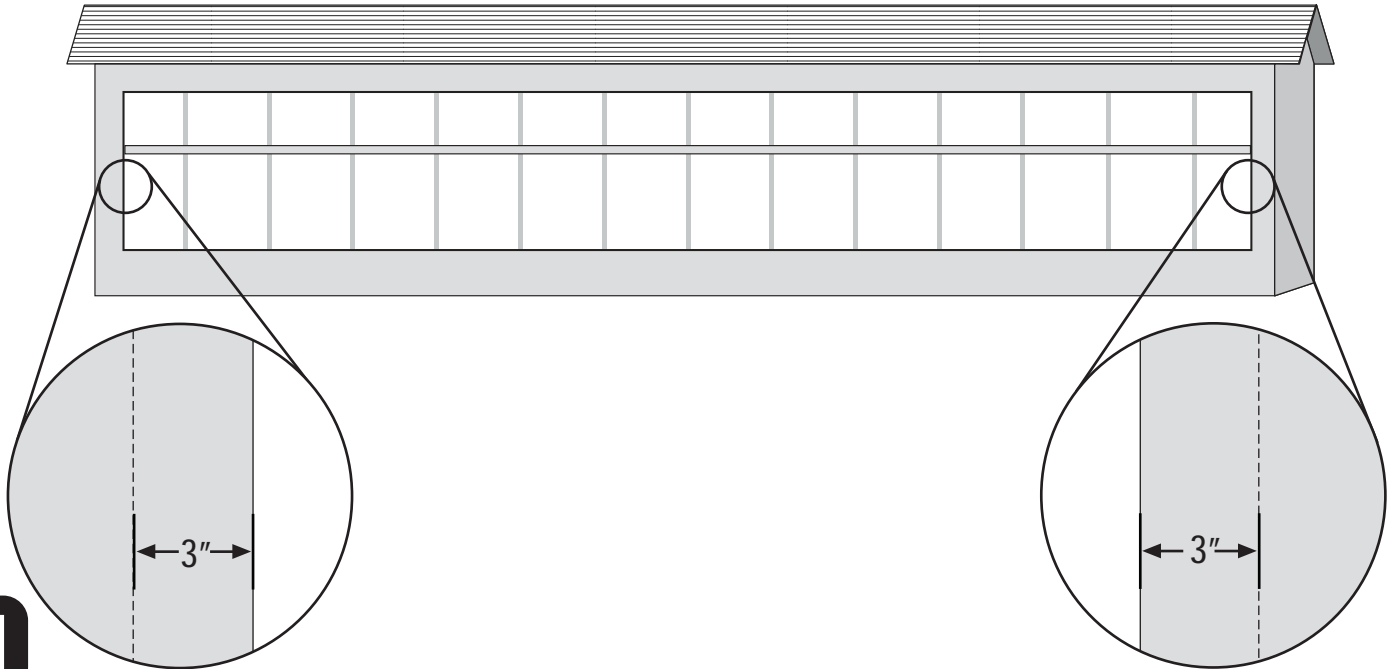

E1

Center back panels vertically then align edge of back panels with lines made in **Step E1** as shown. Using fasteners specific to your building type (refer to **Section B - Page #1** for hardware installation specifications) secure all 3 panel edges that overlap building using panel pre-punched holes as your guide to placement and quantity of hardware required.

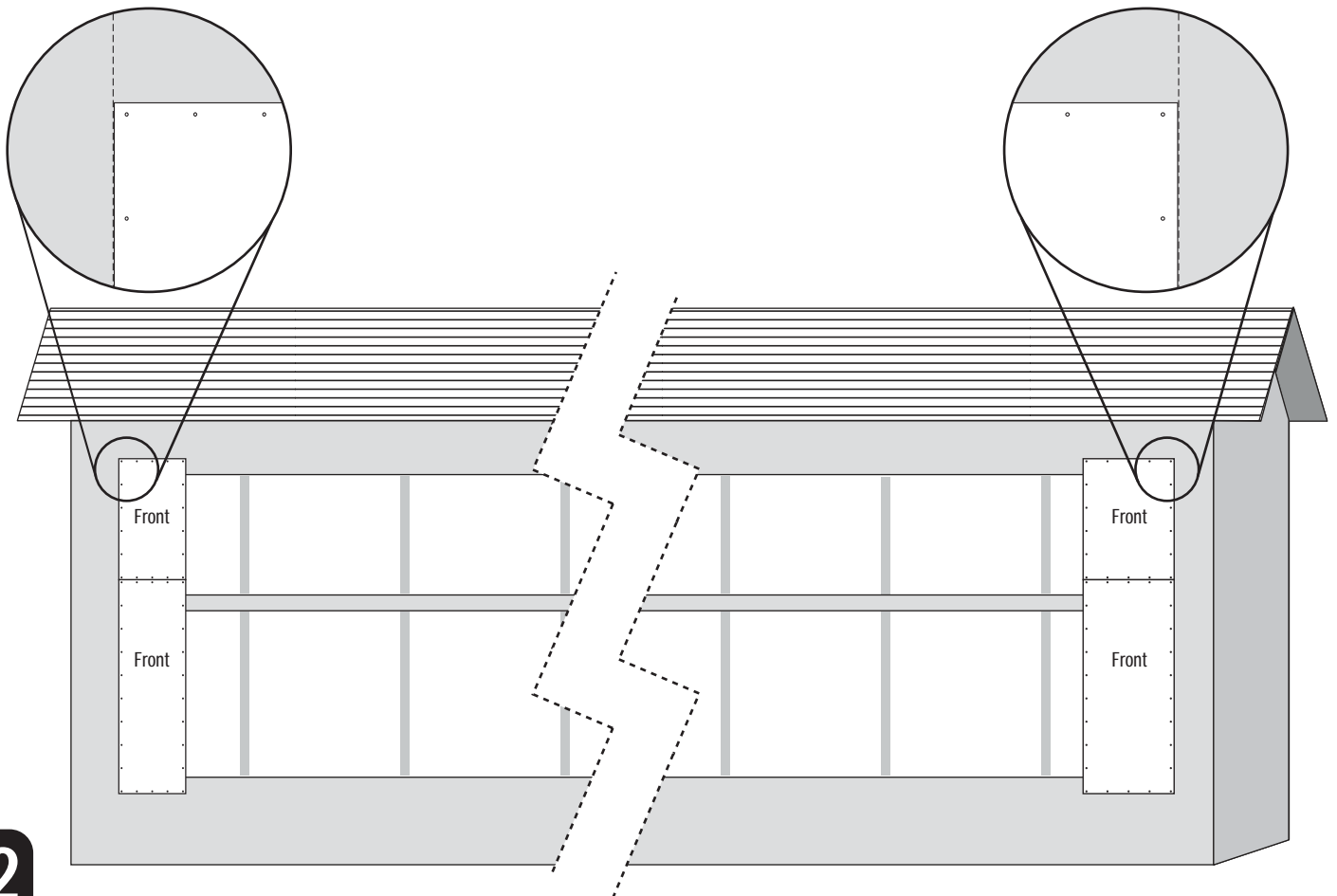

E2

Using pre-punched screw holes on the unsecured edge of the back panels as your guide install interior anchored supports (i.e. vertical stud - not included) centered over screw holes. Once supports are installed, from the exterior secure the edges of back panels to the supports.

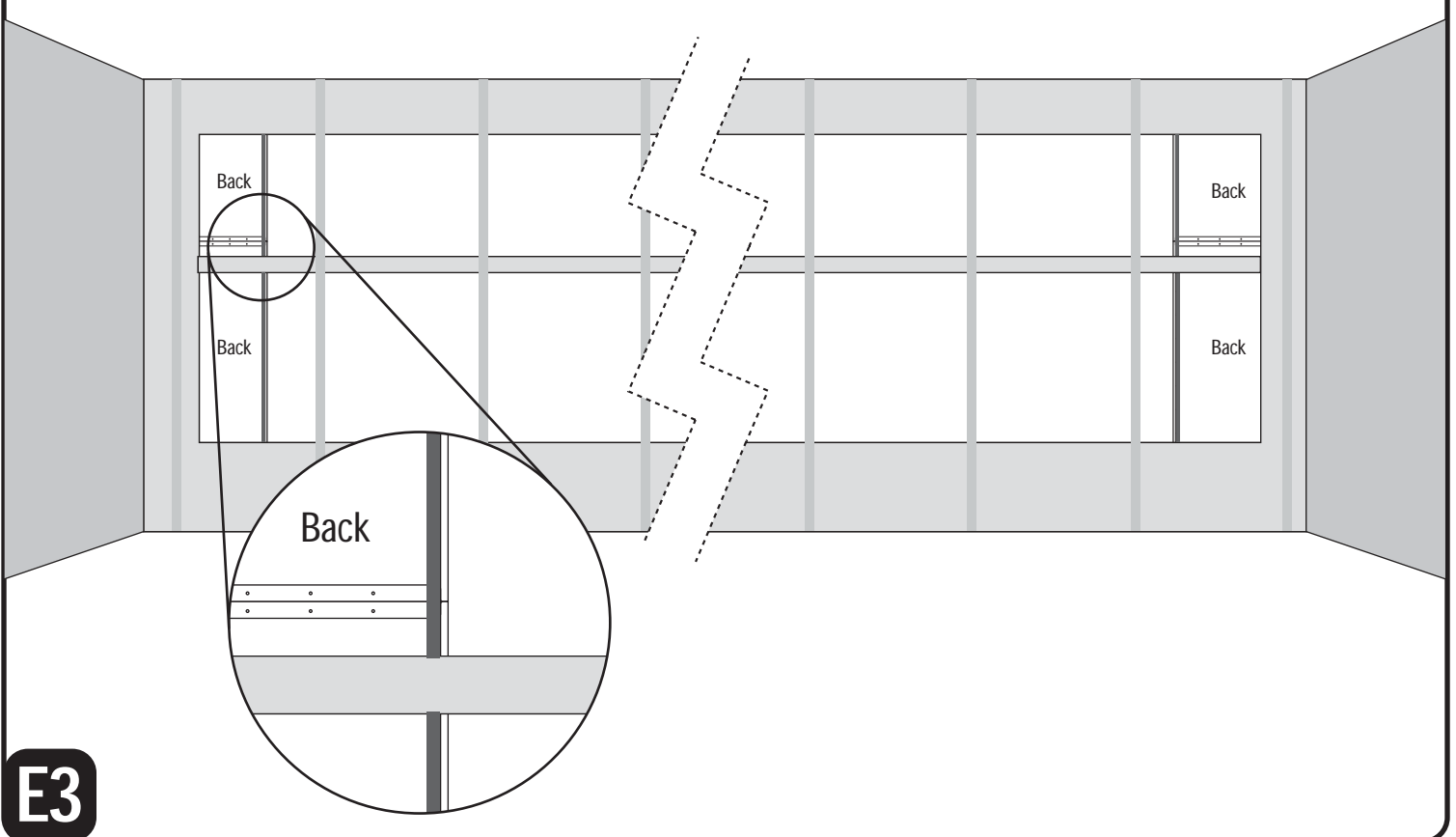
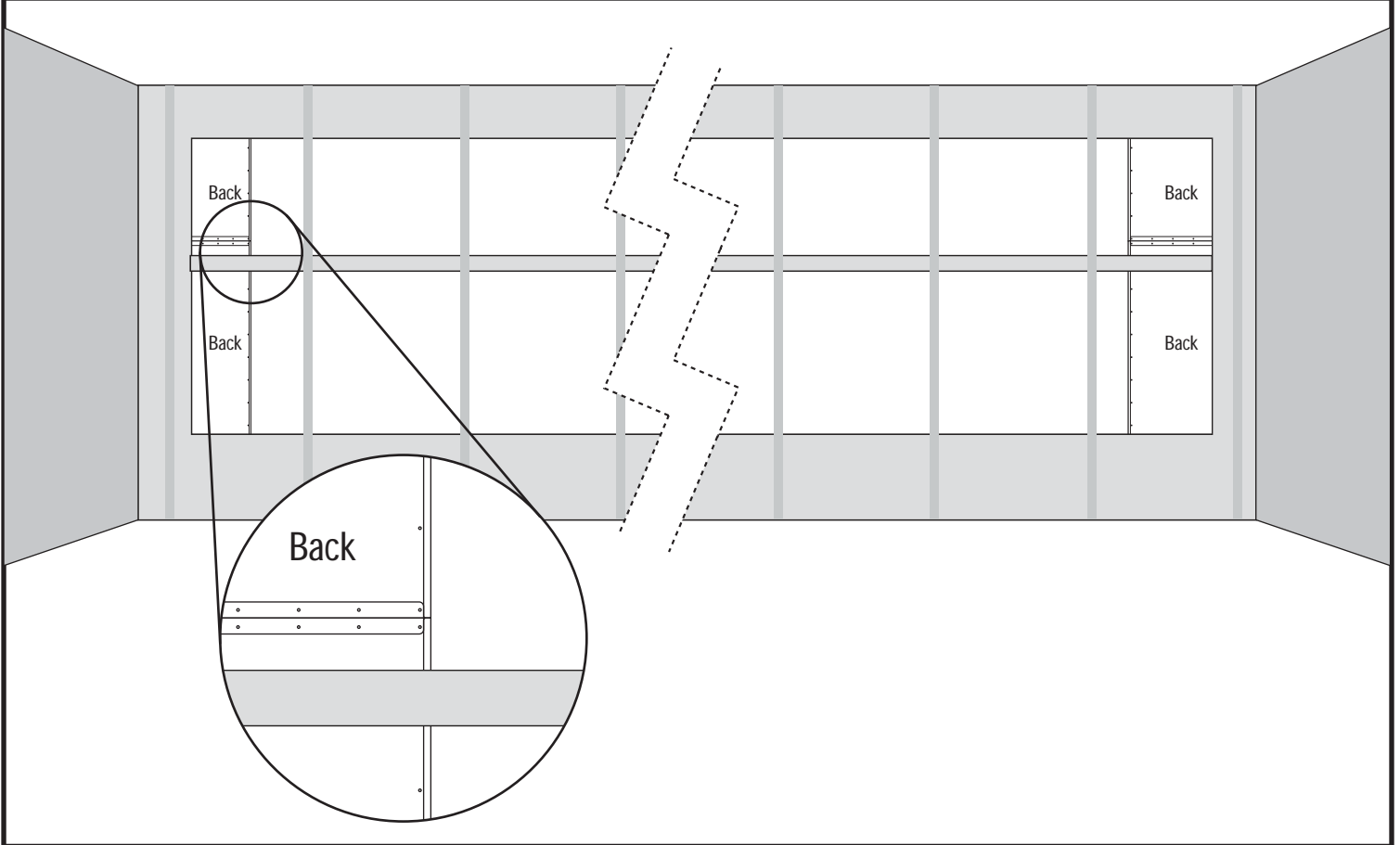

E3

If using interior wind pipes , proceed to Section F.

Measure and mark 1" above the curtain opening. Using a chalk line mark a straight line across the full length of the curtain opening and entire width of the back panels. If installing a two tier system, use the same procedure for the top of the second curtain tier.

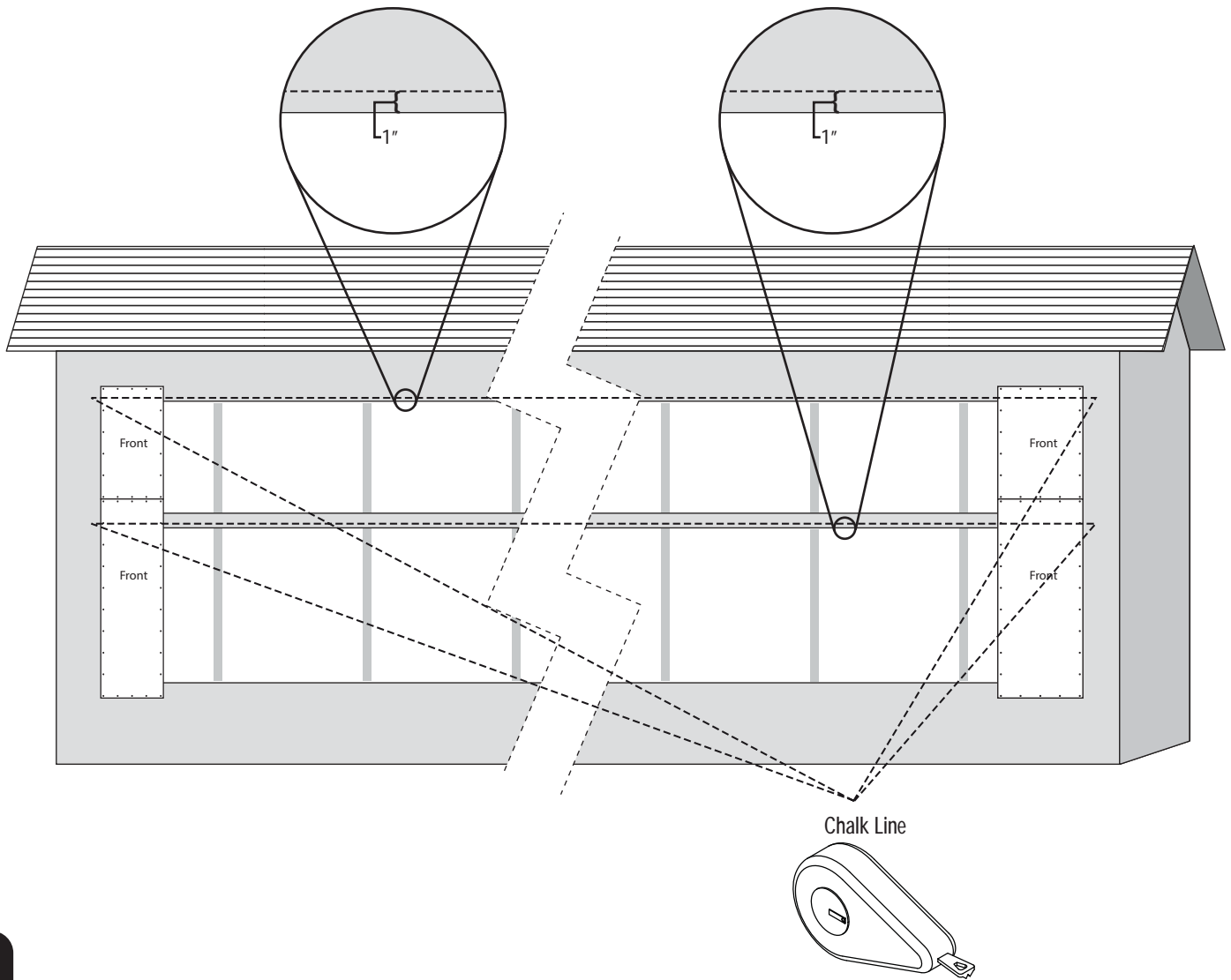

E4

Measure and mark 4' from the curtain opening back panel edge and then every 6' (or as designed by J&D representative). At each of these markings install the interior bottom wind pipe brackets using the top hole only. Be sure that bracket is level and the top of the bracket is resting on the bottom ledge of opening. Secure each bracket using (1) fastener specific to your building type (refer to [Section B - Page #1](#) for hardware installation specifications).

The outside wind pipe bottom bracket installs OVER the inside wind pipe bottom bracket sharing the paired holes and fasteners. Secure each set using (2) fasteners specific to your building type (refer to [Section B - Page #1](#) for hardware installation specifications).

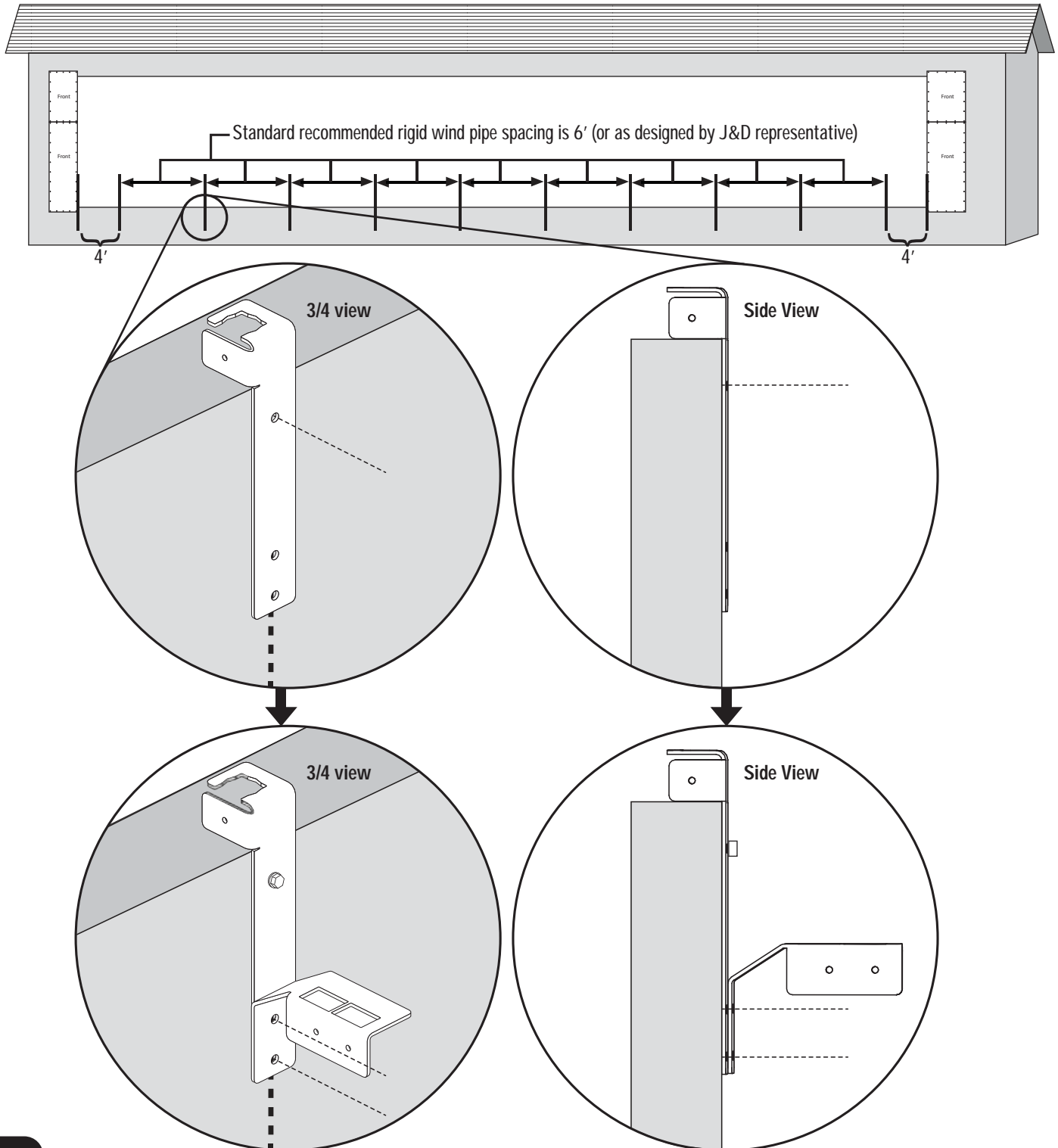

F1

Using the previously installed bottom wind pipe brackets as your guide install corresponding upper interior wind pipe brackets. Secure each bracket using (2) fasteners specific to your building type (refer to **Section B - Page #1** for hardware installation specifications).

Once upper bracket is secured insert interior wind pipe (some trimming may be required) and secure pipe to bottom bracket using (1) 1/4"-14 x 1-1/4" Hex Head Tek Screw and pre-punched hole in side of restraint on bracket.

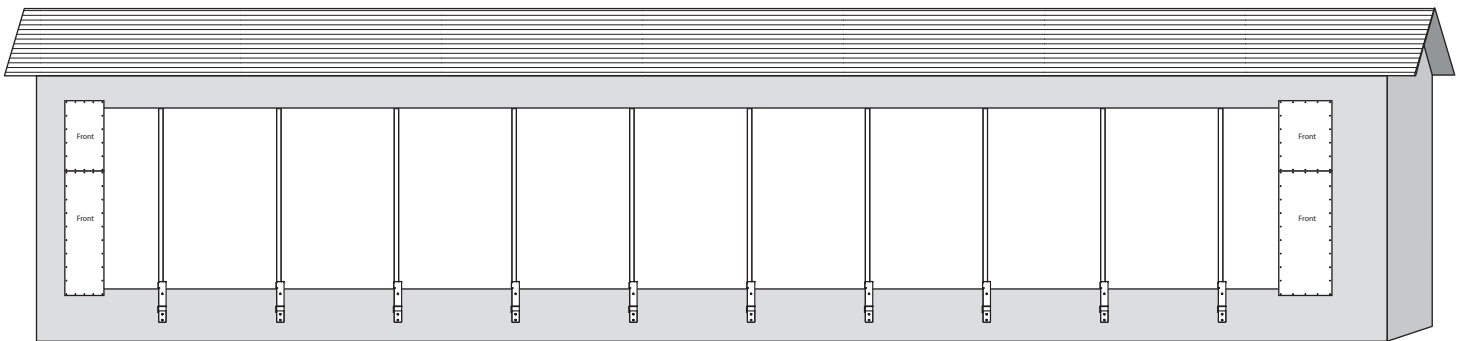
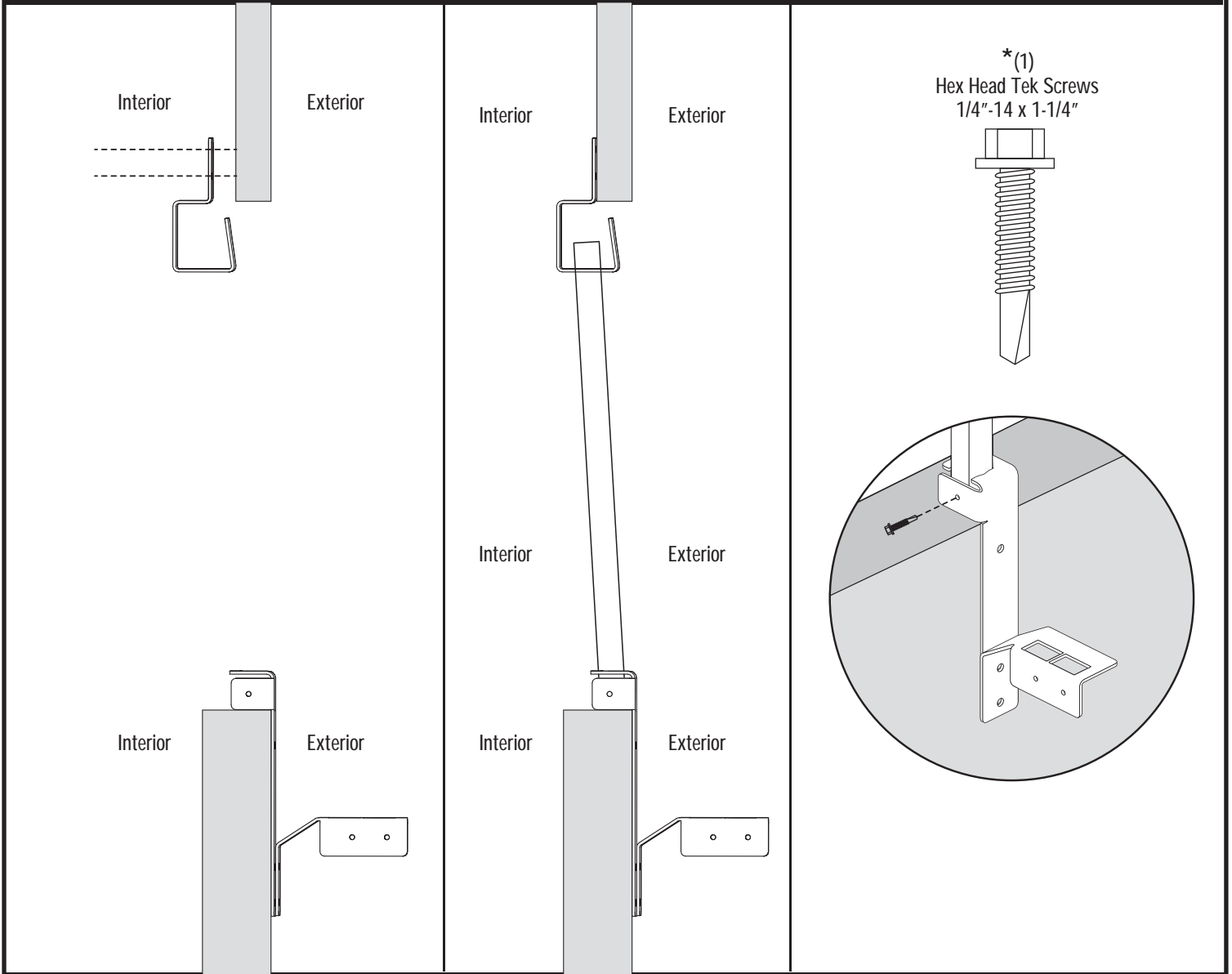

Measure and mark 1" above the curtain opening. Using a chalk line mark a straight line across the full length of the curtain opening and entire width of the back panels. For the second tier system using a chalk line, draw a level horizontal line across each of the interior wind pipes and across the entire width of the back panels.

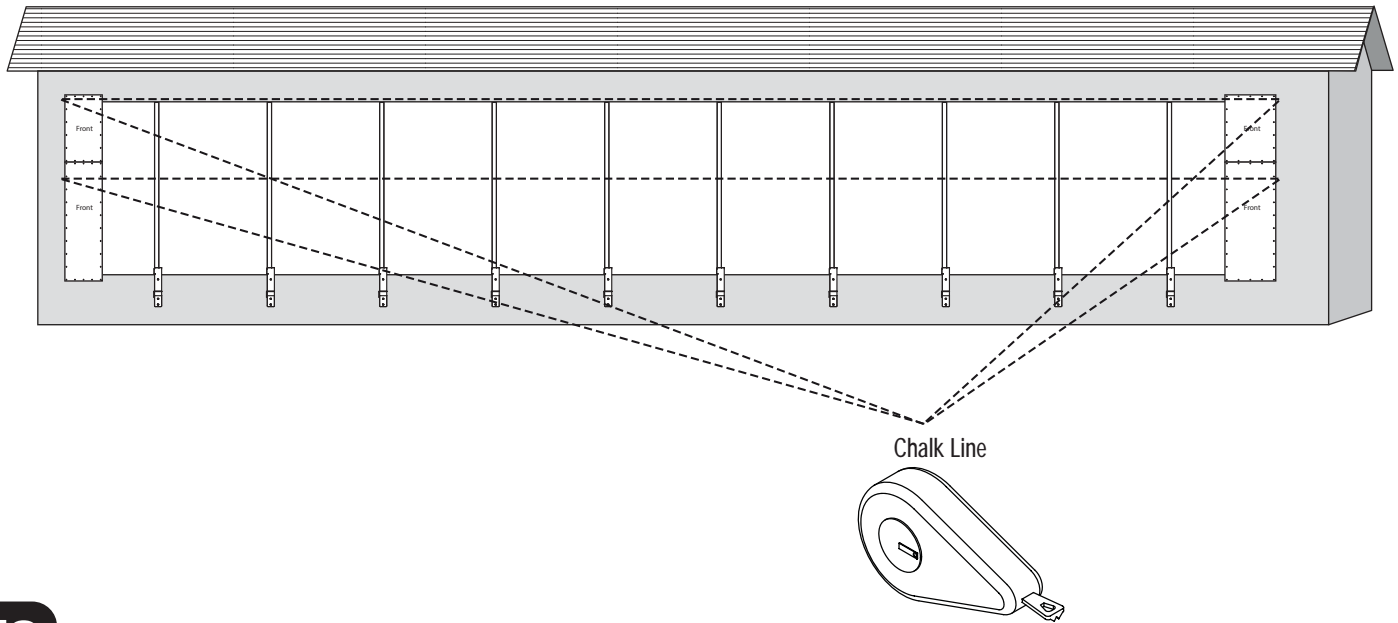

F3

Using level lines on interior wind pipe created on previous step, align bottom edge of roll tube mounting bracket PCSR617, center bracket and secure each using (2) bolt, washer, and nut sets from the HK184 fastener pack (refer to [Section B - Page #1](#) for hardware installation specifications).

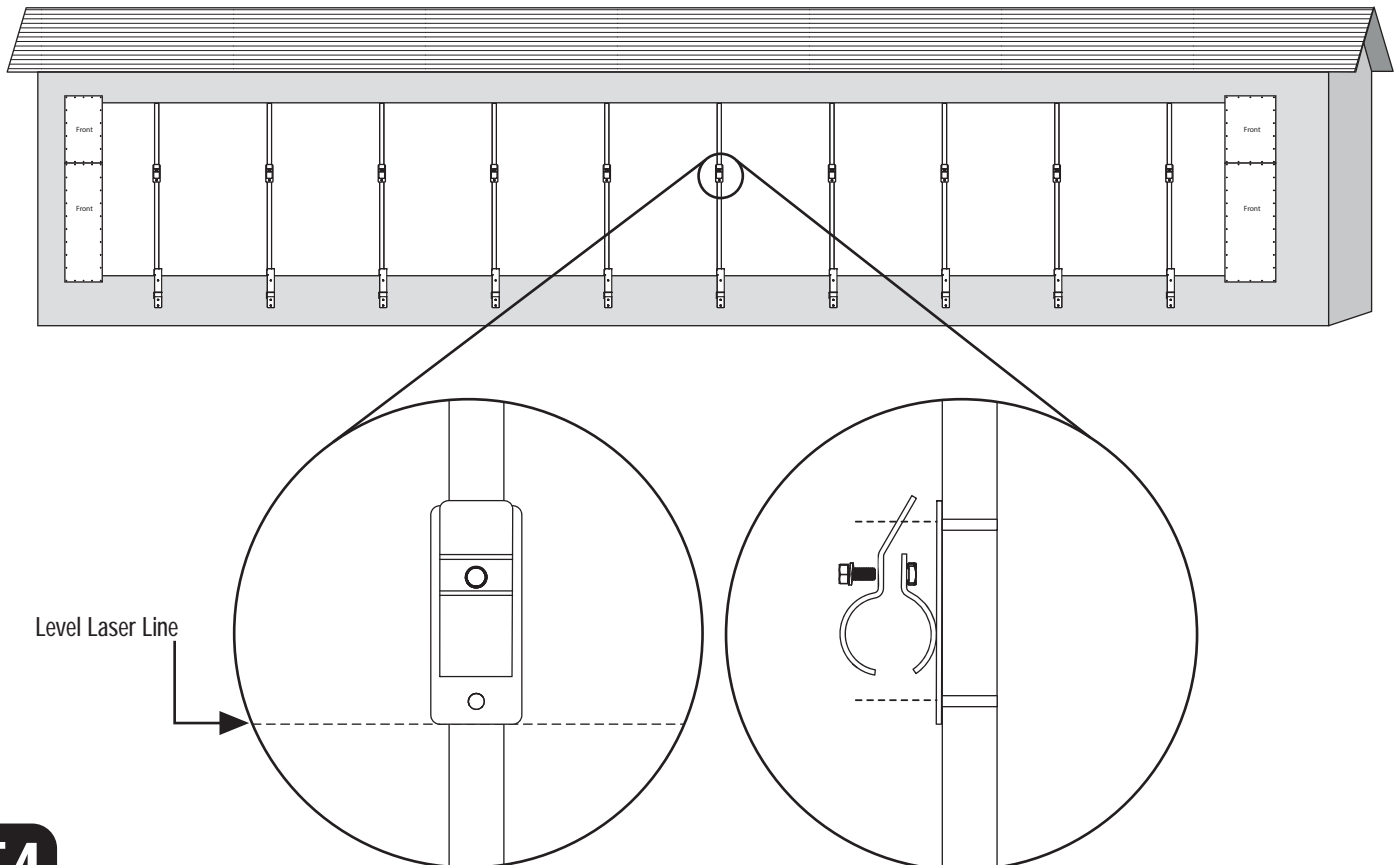

F4

Measure and mark 1" above the curtain opening. Using a chalk line mark a straight line across the full length of the curtain opening and extend a minimum of 3" past the width of the opening on each side to indicate required curtain overlap. If installing a two tier system, use the same procedure for the top of the second curtain.

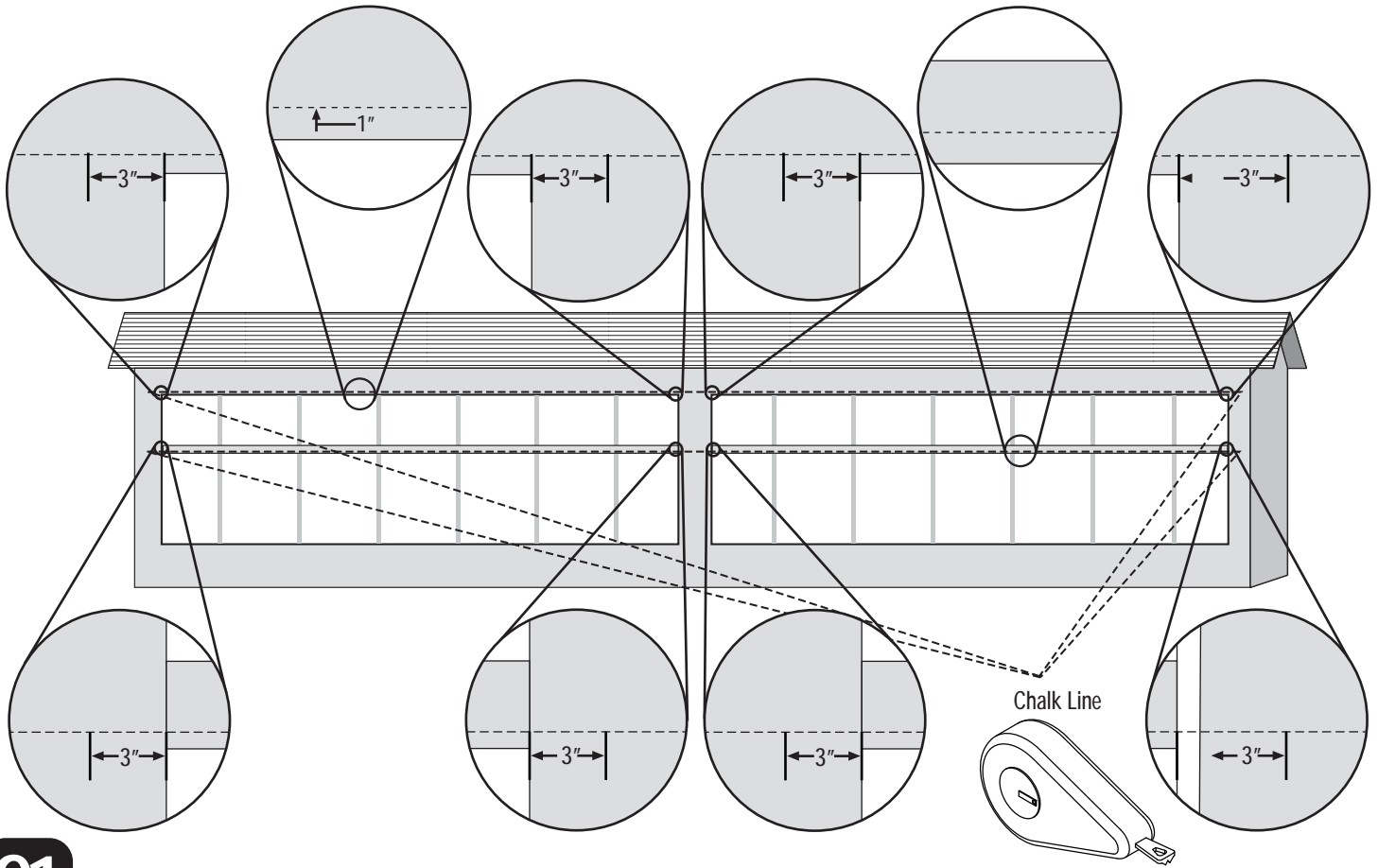

G1

Measure and mark the center of the structure between curtain openings to ensure both sides of curtain will connect to drive.

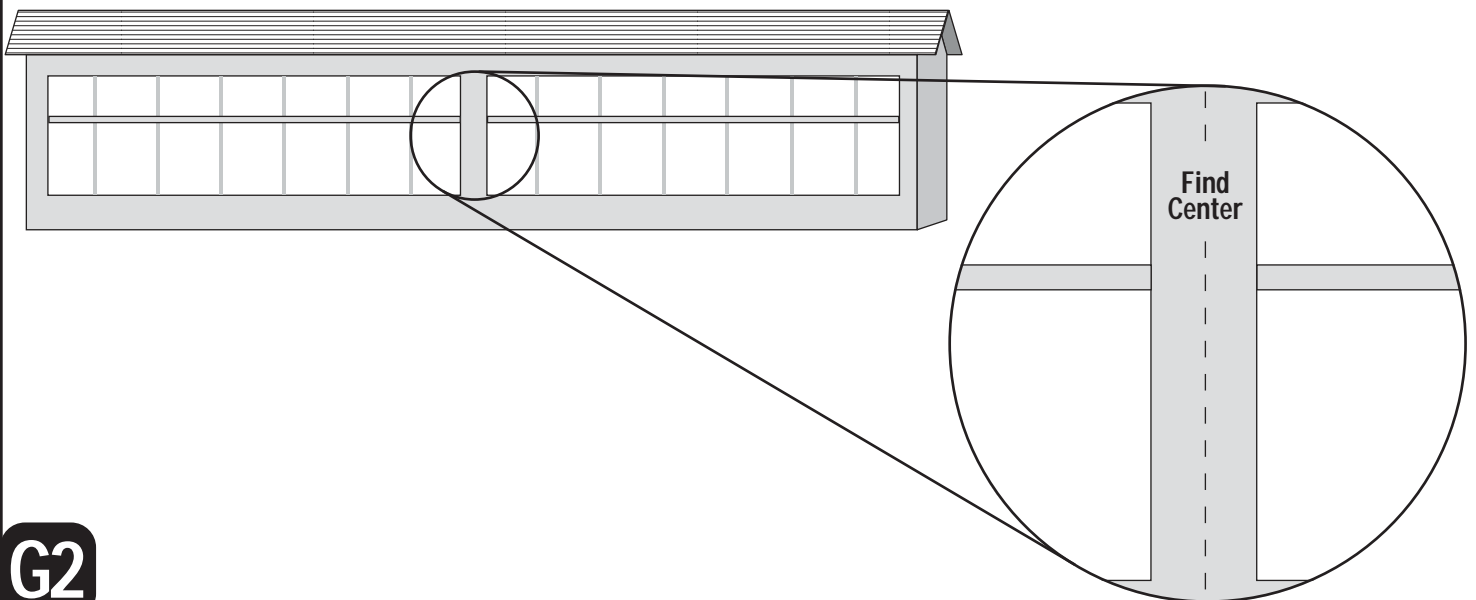

G2

If system will use **ONLY** manual drives proceed to Step G4.

For systems that use a motorized drive, measure and mark $6\frac{1}{2}$ " on both side of center line.

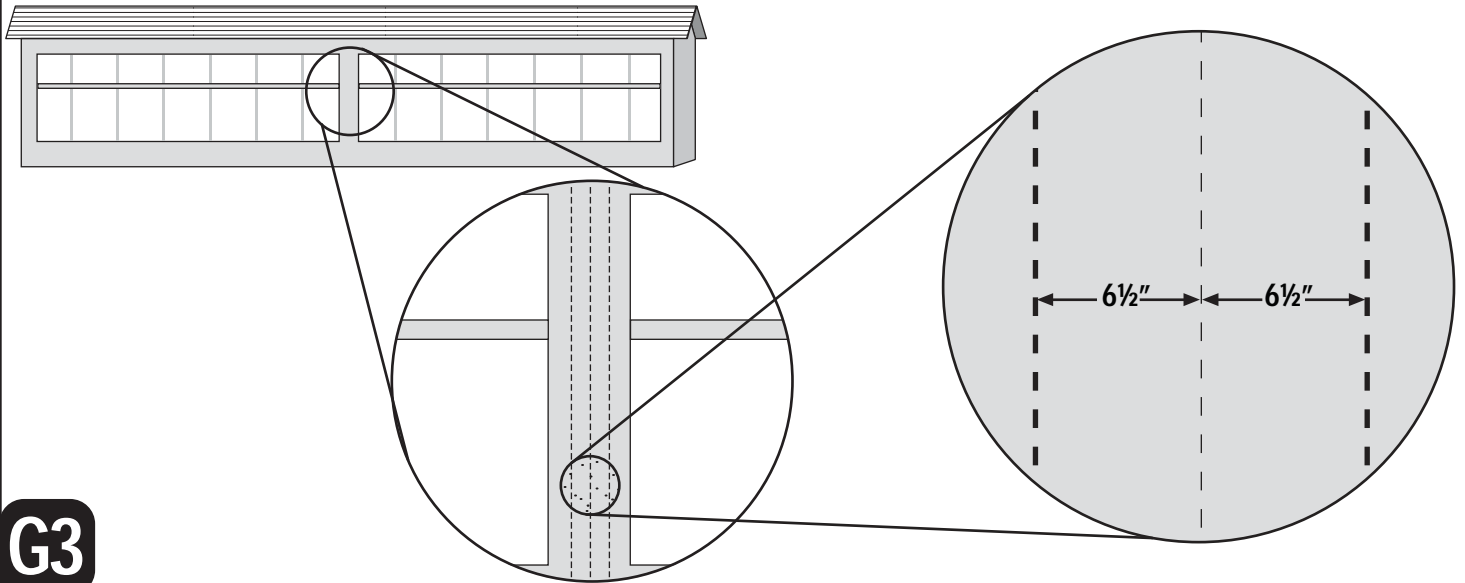

Proceed to notes following Step G4 for further instruction.

If your system uses **ONLY** manual drive/s, measure and mark 5" on both side of center line.

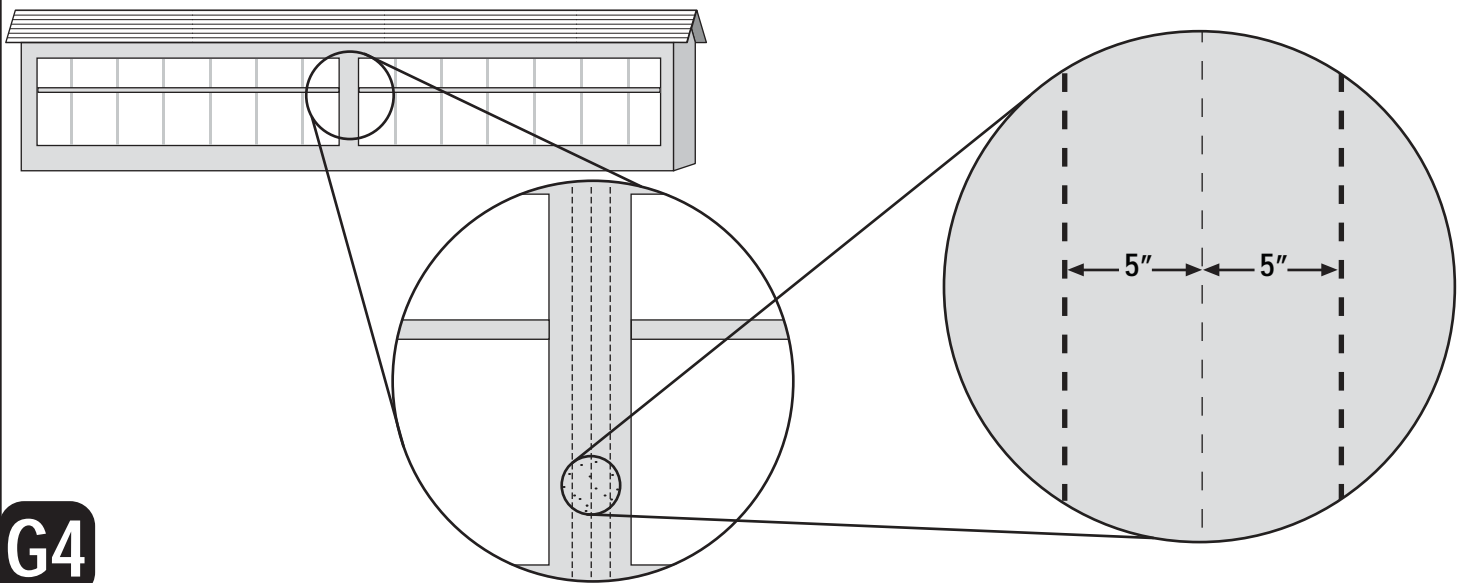

If top of curtain will be secured using PCSR616 tack strip, proceed to Section J.

If top of curtain will be secured using PCSR600 roll tube and PCSR617 roll tube mounting brackets, proceed to Section K.

----- **IMPORTANT** -----

From this point forward, the drawings and instructions for the end drive system will represent a single side of a center drive system unless indicated otherwise. Apply information to each side of the center drive system, noting one side will be a mirrored version, and adjust information accordingly.

Measure and mark 1" above the curtain opening. Using a chalk line mark a straight line across the full length of the curtain opening and extend a minimum of 3" past the width of the opening on each side to indicate required curtain overlap. If installing a two tier system, use the same procedure for the top of the second curtain.

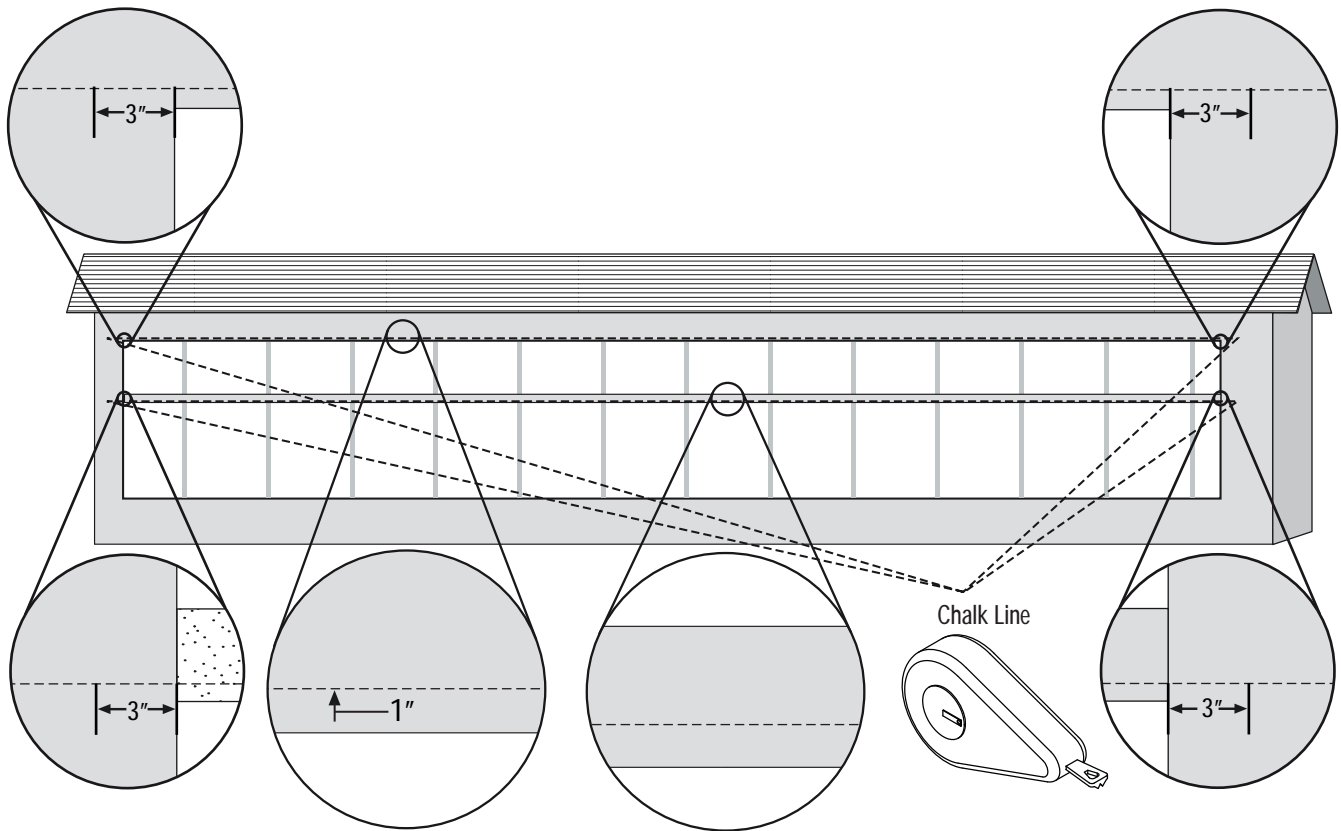

H1

To ensure roll tubes connect with curtain drive/s, measure and mark 7" from edge of opening on drive end.

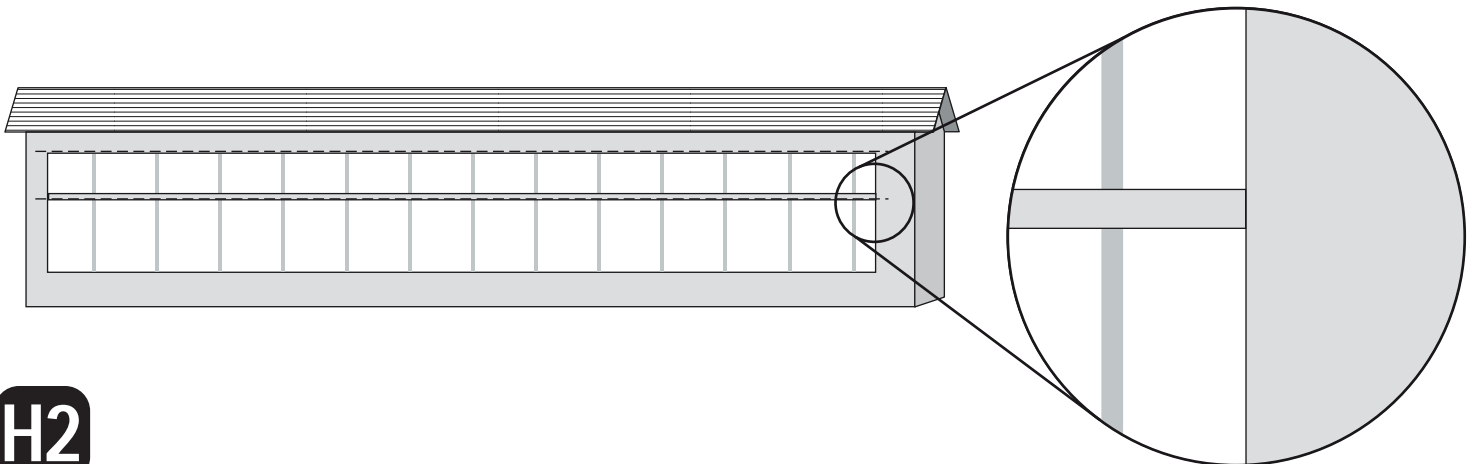

H2

If top of curtain will be secured using PCSR616 tack strip, proceed to [Section J](#).

If top of curtain will be secured using PCSR600 roll tube and PCSR617 roll tube mounting brackets, proceed to [Section K](#).

Measure and mark 4' from the edge of the curtain opening and then every 6' (or as designed by J&D representative). At each of these markings install the interior bottom wind pipe brackets using the top hole only. Be sure that bracket is level and the top of the bracket is resting on the bottom ledge of opening. Secure each bracket using (1) fastener specific to your building type (refer to [Section B - Page #1](#) for hardware installation specifications).

The outside wind pipe bottom bracket installs OVER the inside wind pipe bottom bracket sharing the paired holes and fasteners. Secure each set using (2) fasteners specific to your building type (refer to [Section B - Page #1](#) for hardware installation specifications).

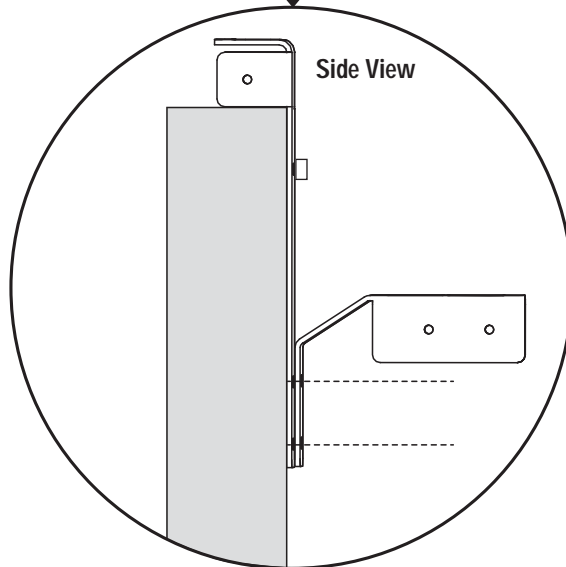
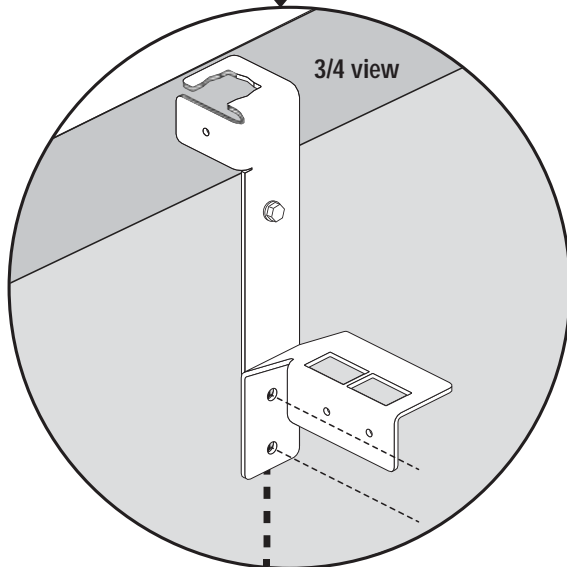
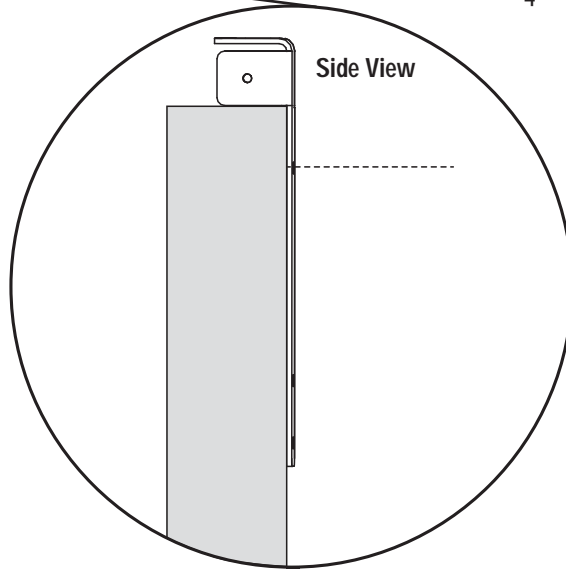
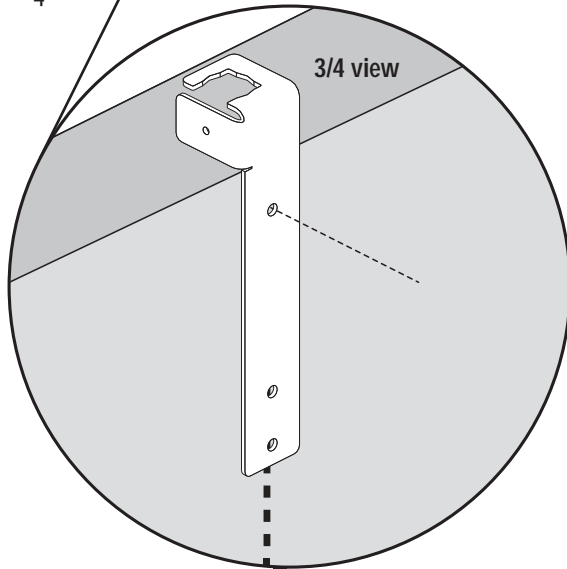
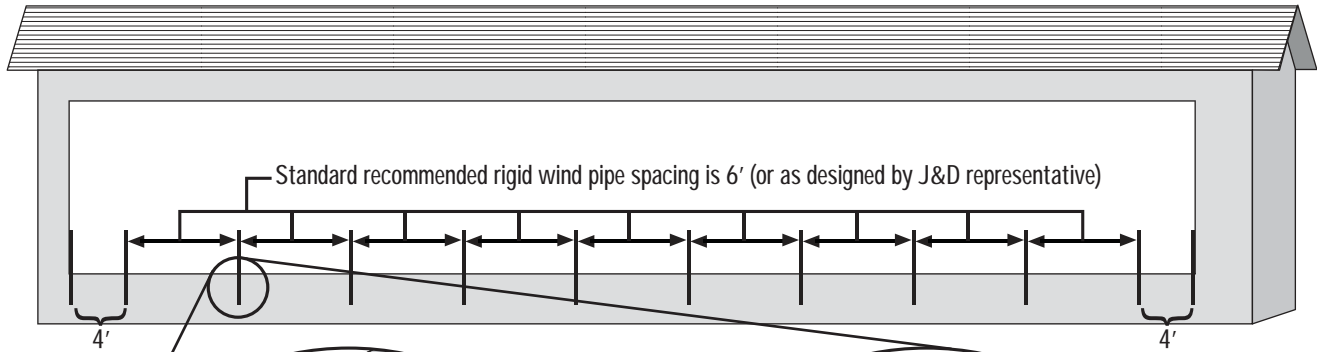

Measure and mark 1" above the curtain opening. Using a chalk line mark a straight line across the full length of the curtain opening and extend a minimum of 3" past the width of the opening on each side to indicate required curtain overlap. For the second tier system using a chalk line, draw a level horizontal line across each of the interior wind pipes and across the entire width of the back panels.

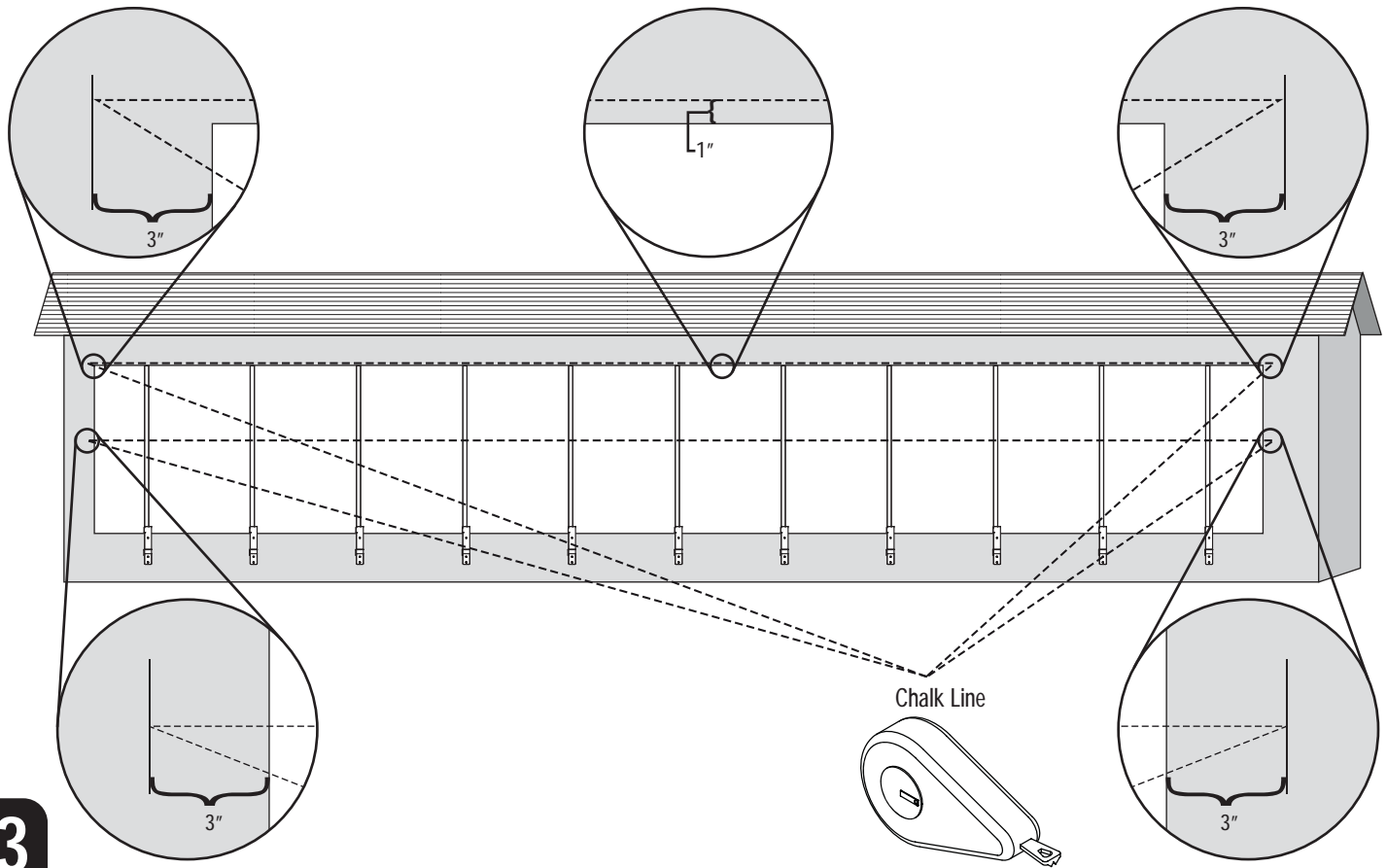

I3

Using level lines on interior wind pipe created on previous step, align bottom edge of roll tube mounting bracket PCSR617, center bracket and secure each using (2) bolt, washer, and nut sets from the HK184 fastener pack (refer to [Section B - Page #1](#) for hardware installation specifications).

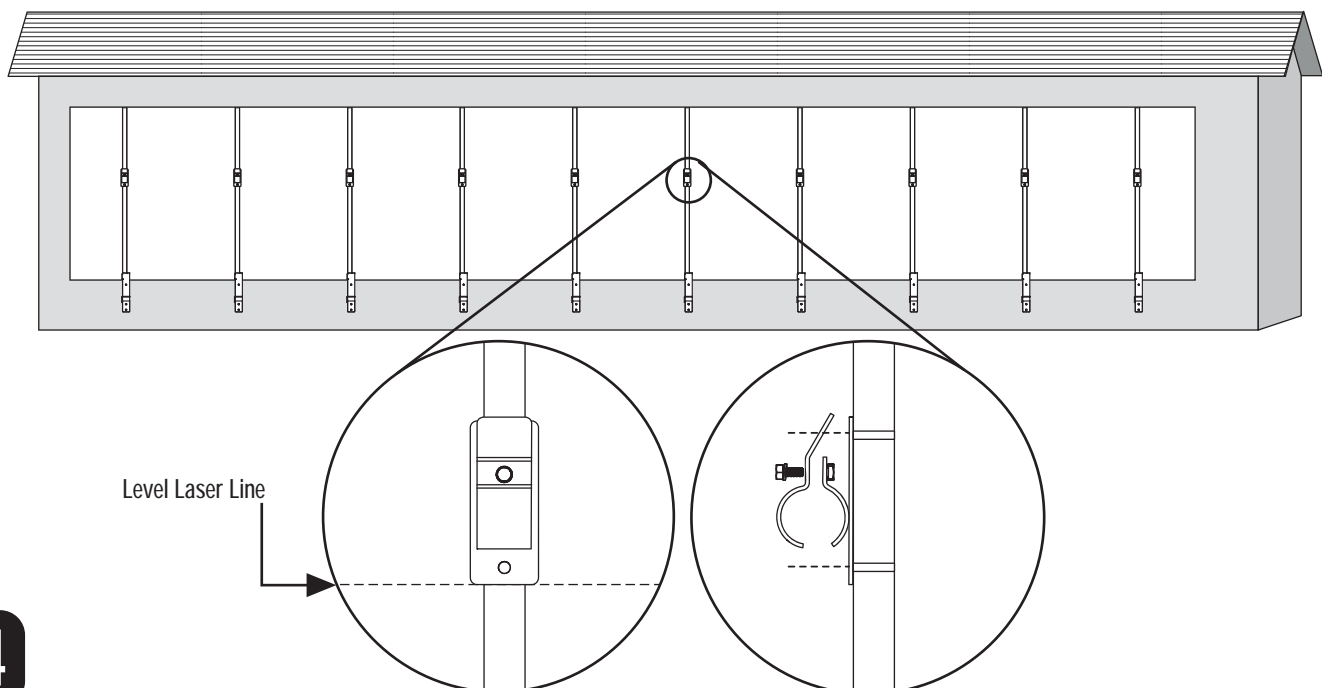

I4

IMPORTANT! If installing a wind strap system, you cannot use a tack strip for hanging your curtain.

If tack strip is cut to fit the installation, deburr cut edges of round curtain Keder track.

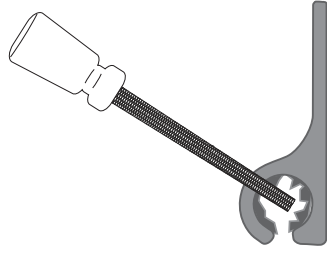

Deburr edges cut on site

J1

Prepare to install the tack strip with bottom edge of tack strip aligned with the chalk line(s) drawn in **Step G1** or **Step H1** for preparing your structure. The tack strip must extend a minimum of 3" past the opening on all sides as noted in **Step G1** and **Step H1**.

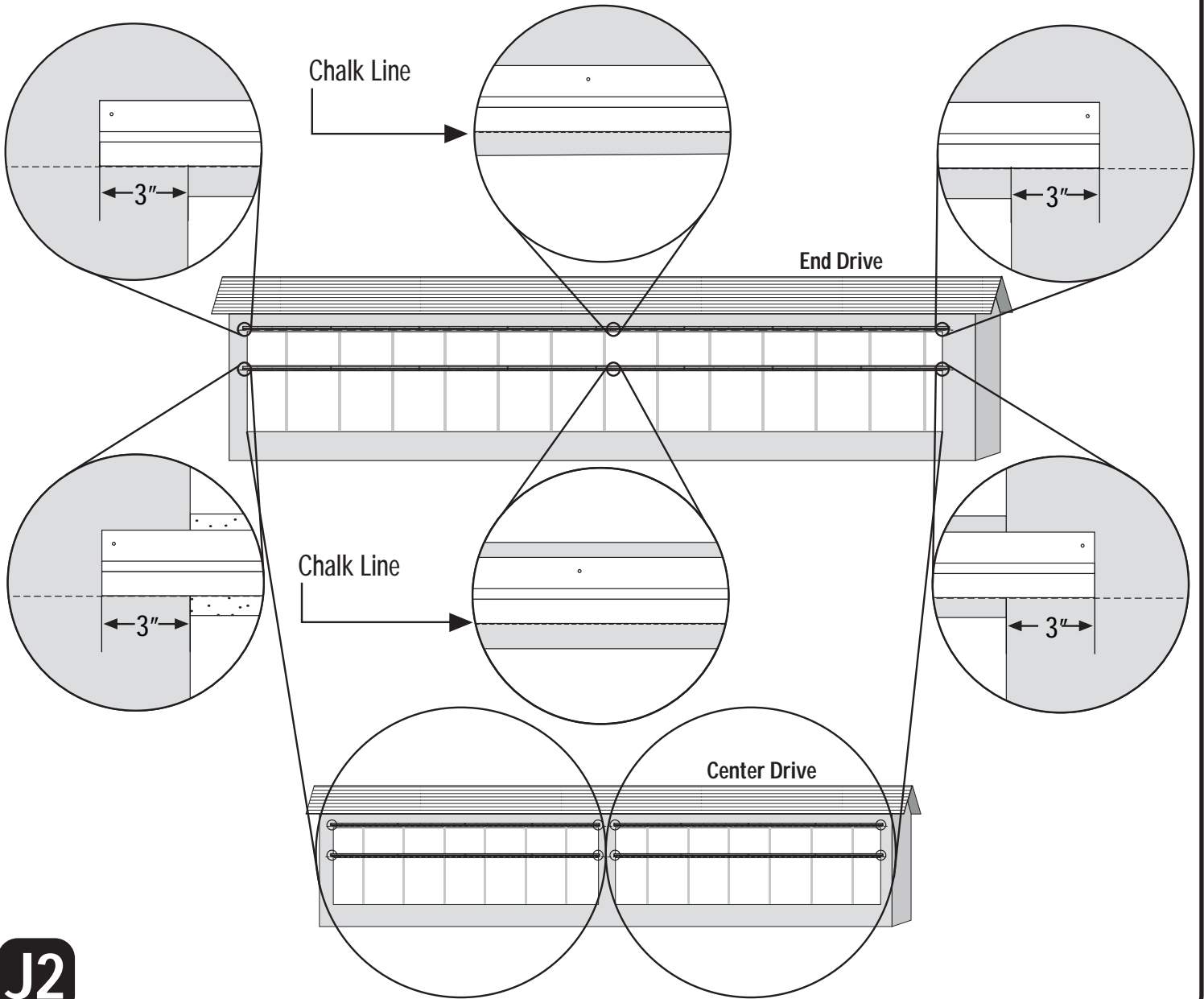

J2

Mark the bolt placement using the 5 holes shown below as your guide. Secure each tack strip using (5) lag bolts from the HK181 Wood Fastener Pack. Continue installing tack strip and lag bolts along the width of the structure, ensuring the tack strip remains level, and that each tack strip fits tightly against the previously installed tack strip. If fastening tack strip to steel building, use (9) self drilling screws from HK182 Steel Fastener Pack.

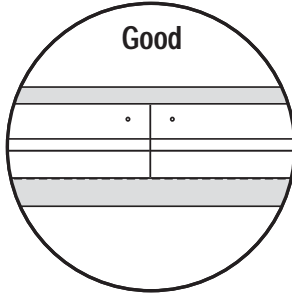
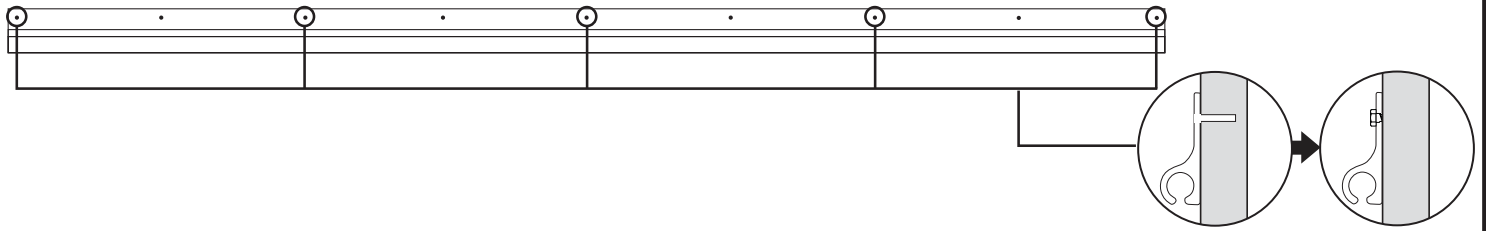

Tack strips must but up tightly against each other

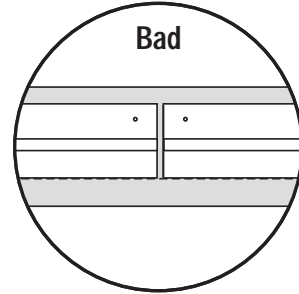

J3

Once all tack strips are mounted using lag bolts, go back and further secure each tack strip with (4) sets of hex bolt, washer, and Nylock nut from HK184 fastener pack for tack strip

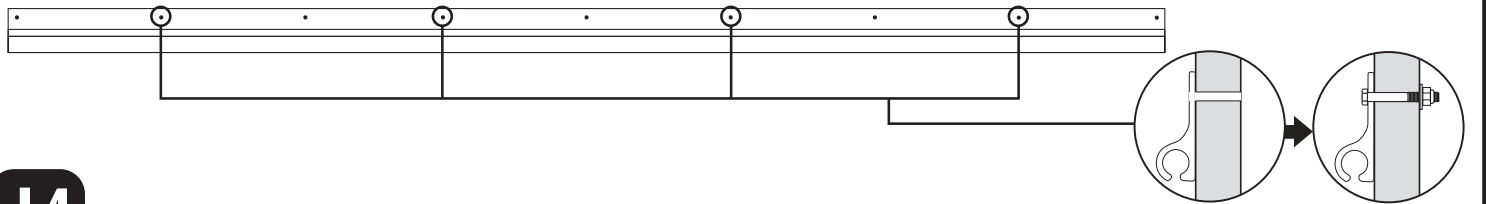

J4

To speed assembly and installation, pre-measure and mark all roll tubes and roll tube splices as shown below regardless if roll tubes will be used for hanging or rolling curtain.

Before installing curtain roll tubes, prepare the tubes for future splice placement by measuring and marking lines as shown below. On one end of the roll tube, mark a line in the flat channel at 1" and 4" from the end of the tube. On the same end of the roll tube, rotate the tube and mark a line in the flat channel at 2" and 5" from the end of the tube. This will offset the screws during installation so they do not touch. Repeat on other end of roll tube.

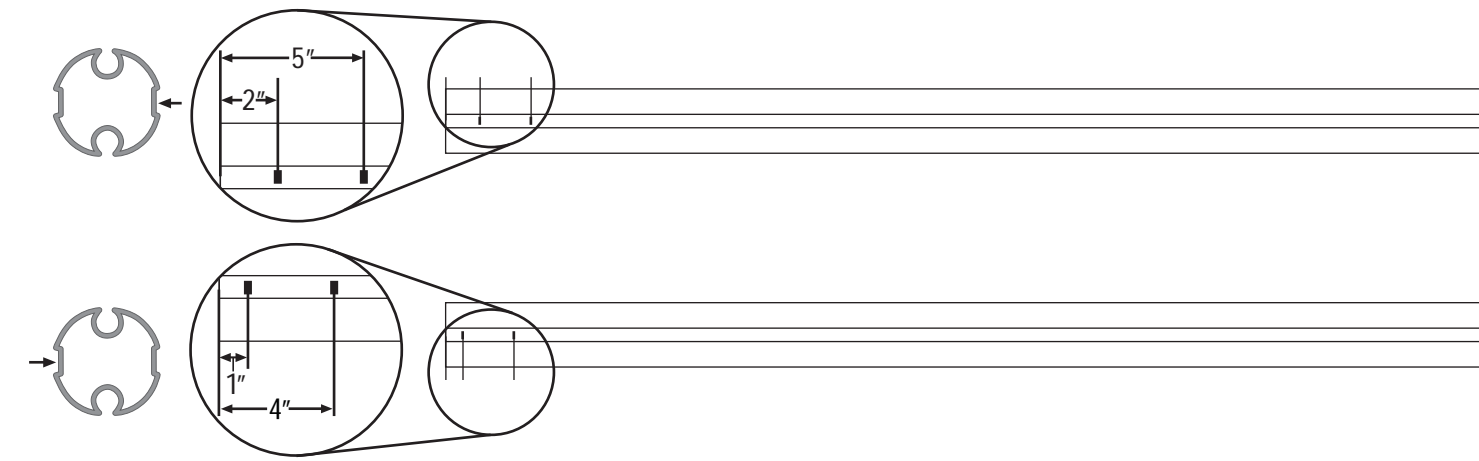
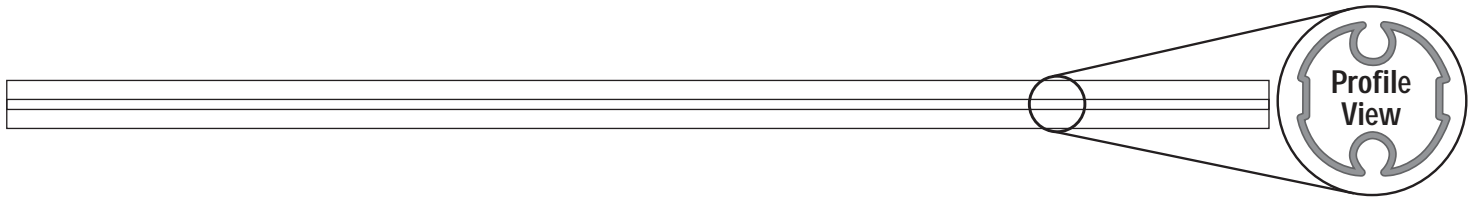

K1

If roll tube is cut on site, deburr cut edges of round curtain Keder track to allow for curtain and keder to pass through without damage.

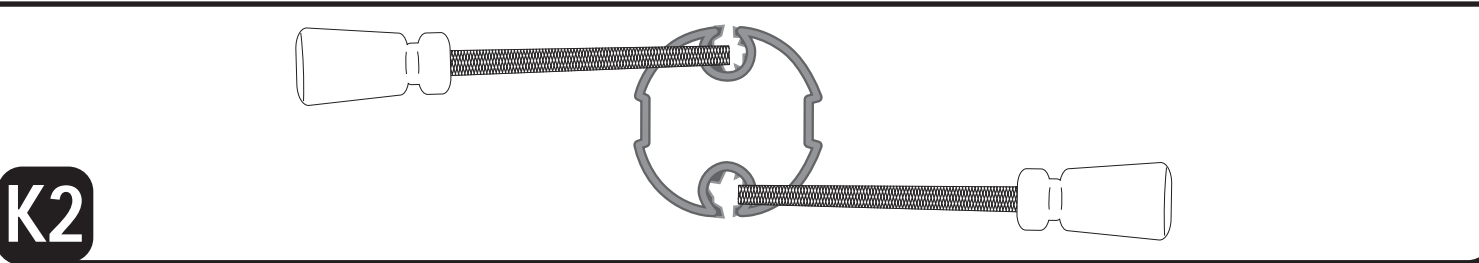

K2

Prepare curtain roll tube splices for future placement by measuring and marking a line 6" from either end indicating the center of the roll tube splice.

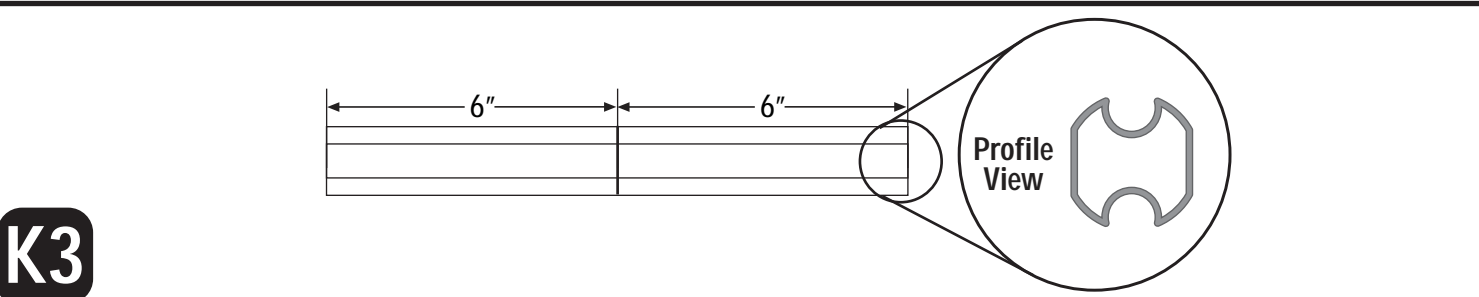

K3

If top of curtain was secured using PCSR616 tack strip, proceed to [Section M](#).

Using the measurement created in [Step G1](#) OR [Step H1](#) as your starting point (3" from edge of opening), measure and mark 4' from the edge of measurement at dead end. Then proceed to measure and mark every 8' (or as designed by J&D representative) until you reach the end of the opening.

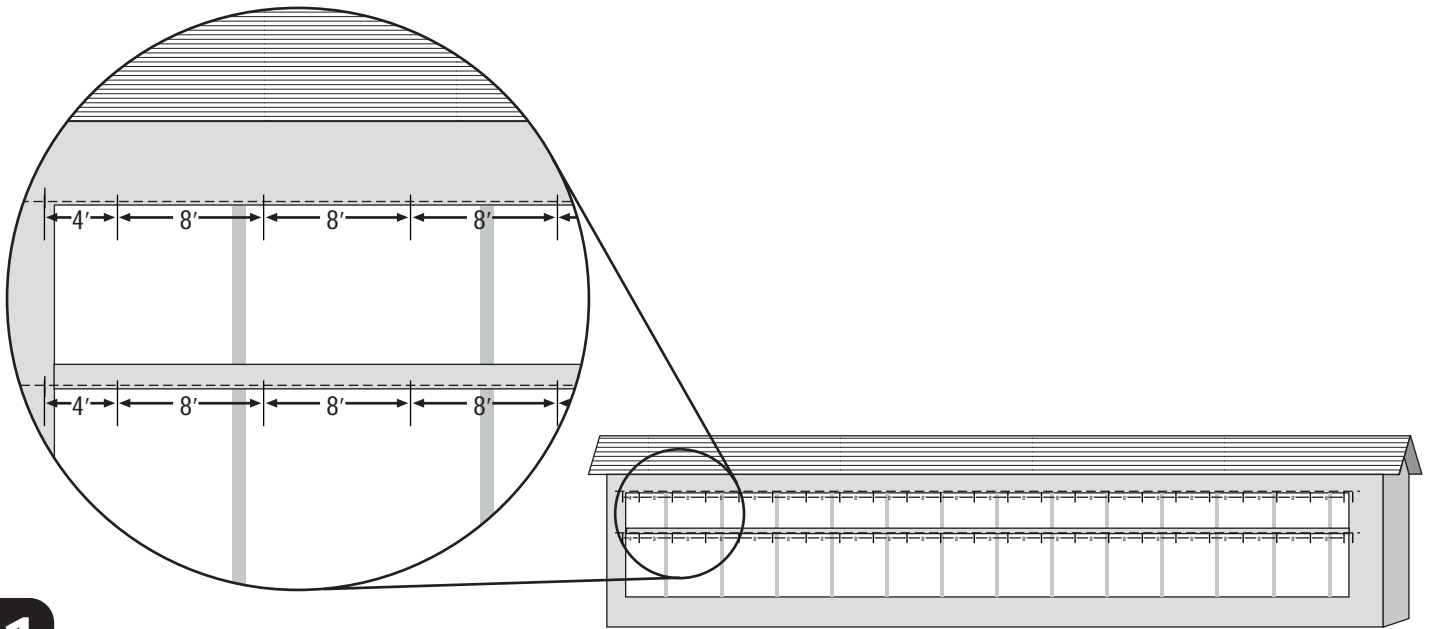

L1

Install a roll tube mounting bracket at each mark made in [Step L1](#) by aligning the bottom of each bracket with the chalk line made in [Step G1](#) or [Step H1](#). Secure each bracket using (2) fasteners specific to your building type, refer to [Section B - Page# 1](#) for hardware installation specifications.

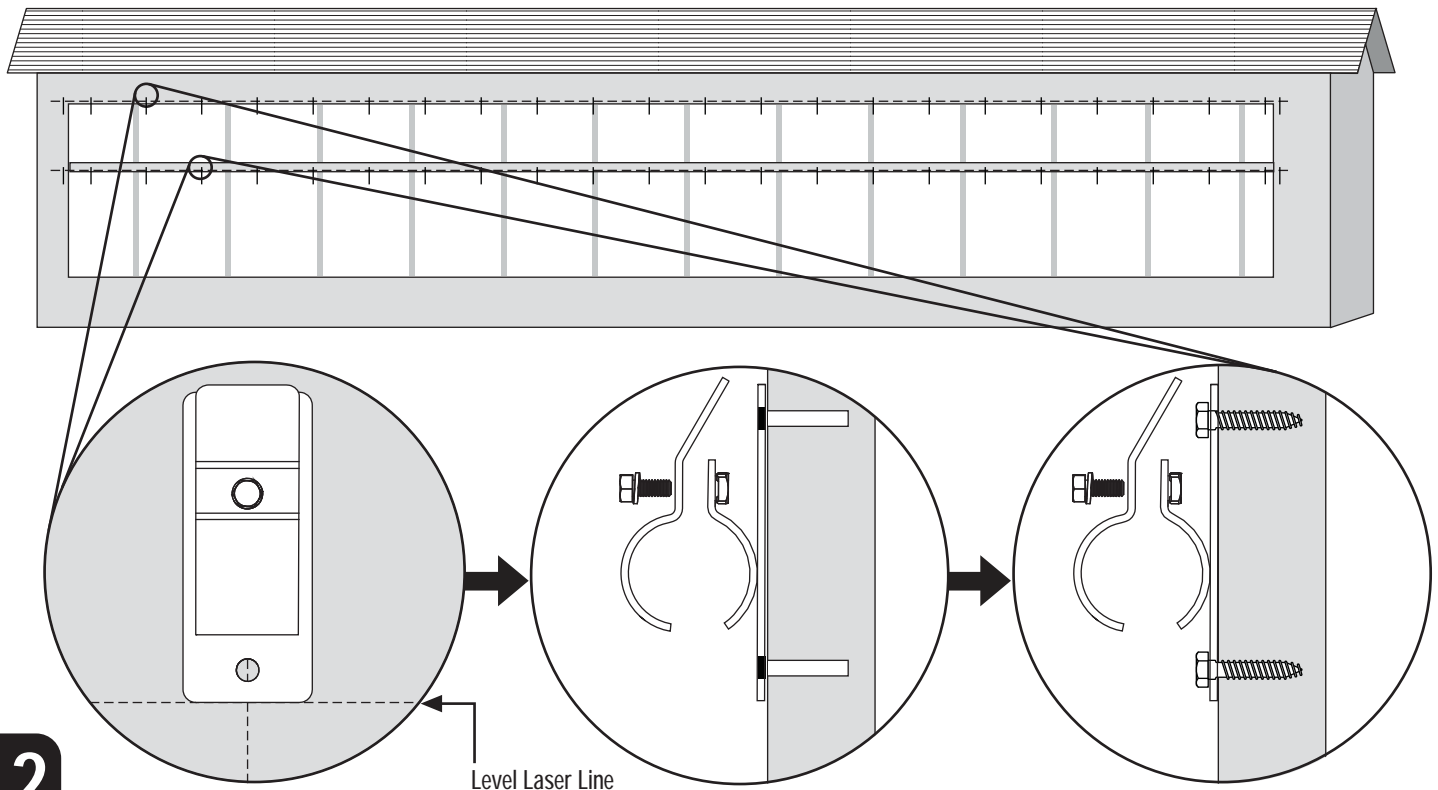

L2

Level Laser Line

Install first piece of roll tube into roll tube mounting brackets. Do not tighten brackets. You will need to be able to rotate the roll tubes for splice installation. Once the entire length of roll tube is assembled, it will be rotated to the correct position and tightened. Connect adjoining roll tubes by inserting a splice into the end of a roll tube. Use the center mark made in **Step K2** as your guide for how far to insert the splice. Secure splice using provided (4) #10 x 1" square head tek screws. These are self tapping, so no pilot hole is needed. Use marks made in **Step K1** as your guide for placement.

Once splice is secure, slide on next roll tube until it is tightly abutted to the previous roll tube. Secure roll tube to splice using (4) #10 x 1" square head Tek Screws. Use marks made in **Step K1** as your guide for placement.

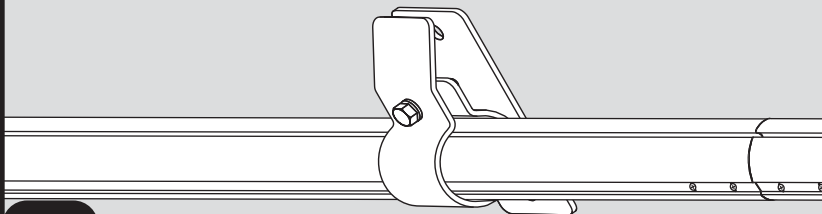
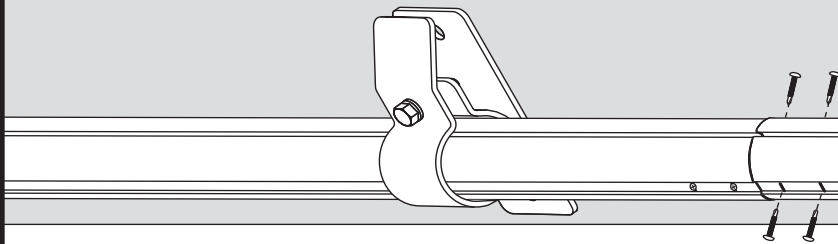
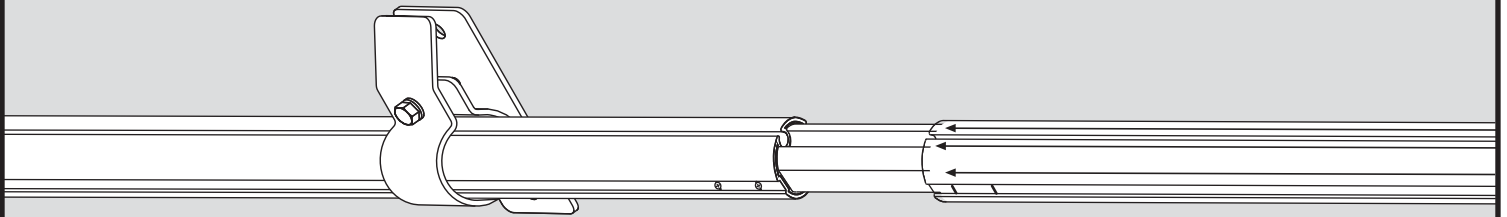
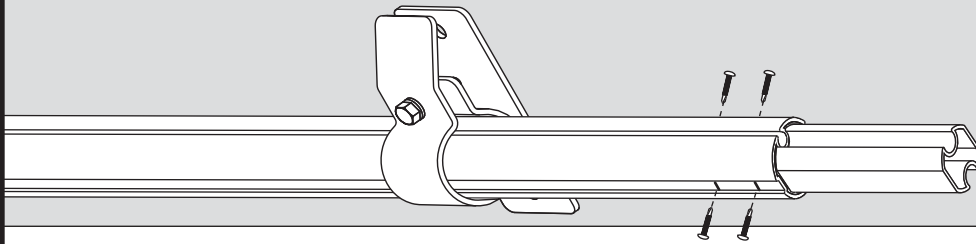
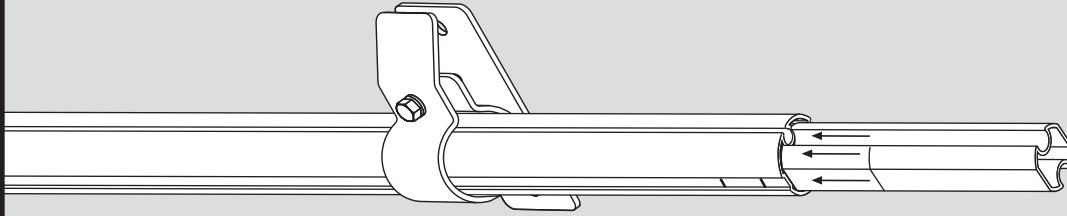
**L3**

Roll tube must extend a **minimum** of 3" beyond opening both on the drive end and dead end of curtain opening. Continue assembling the roll tube by repeating **Steps L3** until you reach the required length. Use a saw to cut the last roll tube to length as needed to properly fit your system. Before assembling this piece of tube, deburr cut edges of round curtain track to allow for curtain and Keder to pass through without damage.

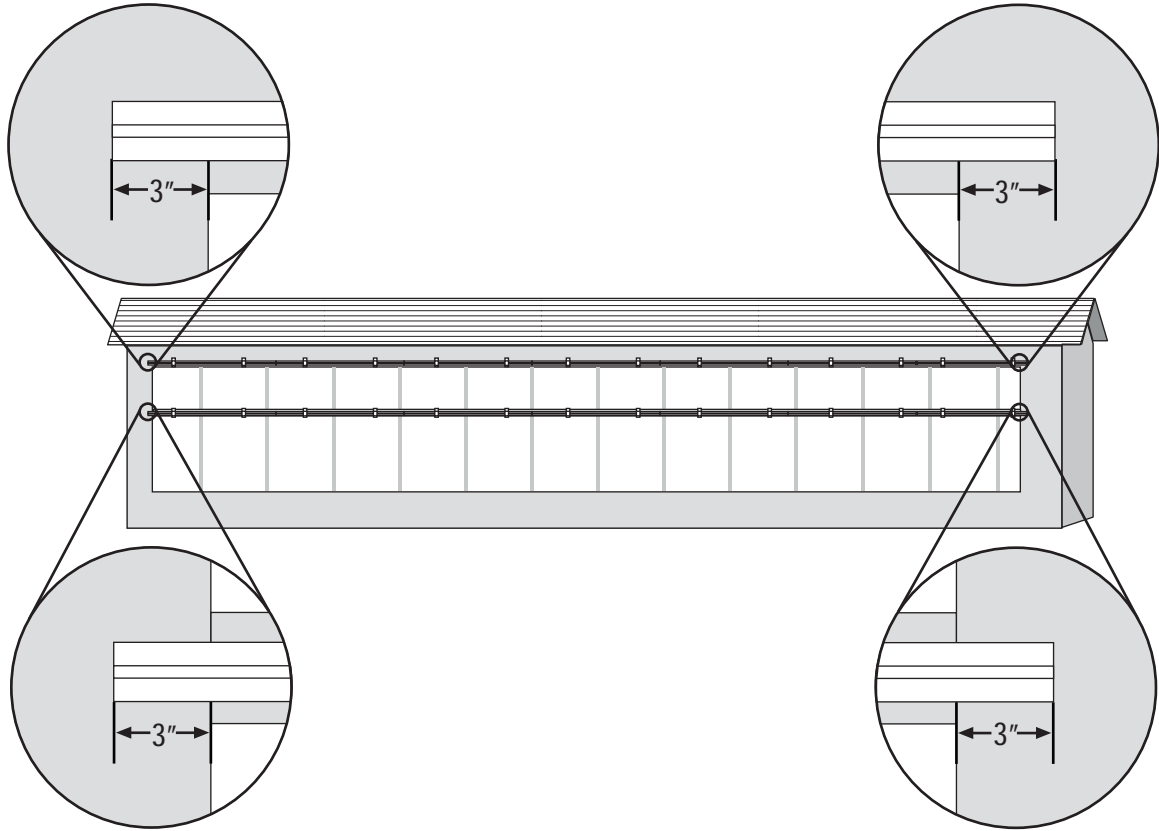
L4

Rotate assembled roll tube so that the curtain track is facing straight down parallel to ground as shown below. Tighten roll tube mounting brackets to secure roll tube into position.

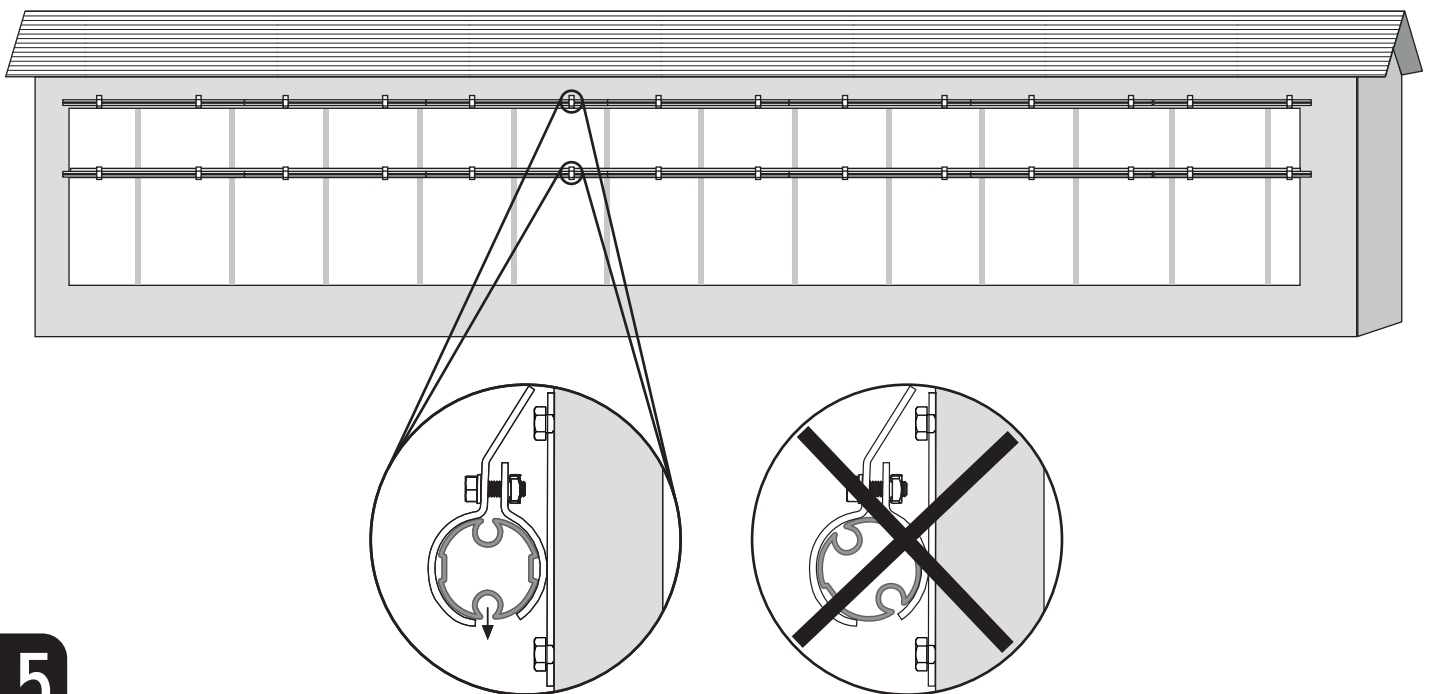
L5

NOTE: PCSR-TACK and PCSR-ROLL curtain guides are optional, not supplied, and purchased separately.

If not using optional curtain guides PCSR-TACK or PCSR-ROLL proceed to Step M2

If using the optional PCSR-TACK curtain guide remove the hardware from the edge of the tack strip as shown, lift the end of the tack strip and slide the PCSR-TACK beneath it. Align the hardware hole in the end of the tack strip with the hole in the guide and secure with hardware previously removed.

If using the optional PCSR-ROLL curtain guide simply insert guide into end of roll tube as shown.

TIP: Elevating and feeding curtain into track guides will ease installation. Once entire curtain panel is inserted remove guides and reuse as needed.

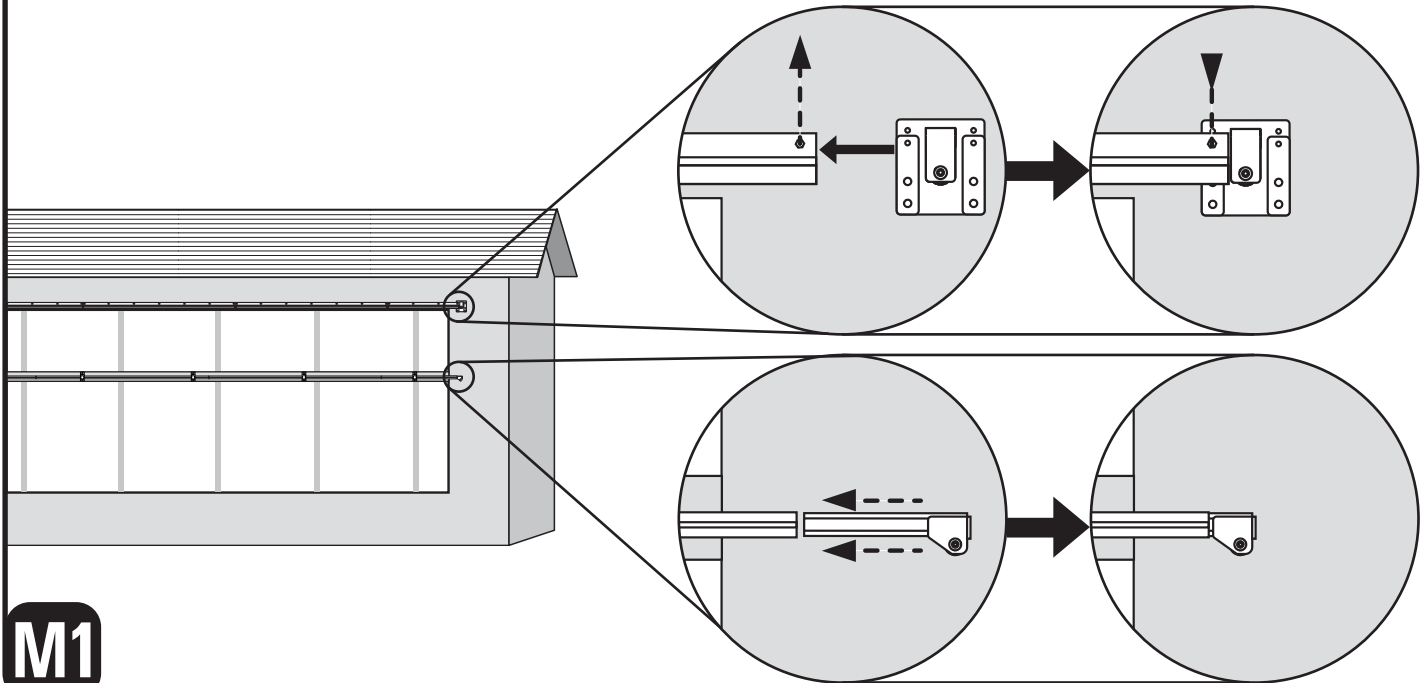

M1

If NOT using the optional PCSR-TACK or PCSR-ROLL curtain guides it is necessary to prep the feeding end of the roll tube or tack strip to prevent damage to curtain and to ease installation. Use a flat file to round the edges of Keder track as shown below.

TIP: Elevating and feeding curtain into track guides will ease installation.

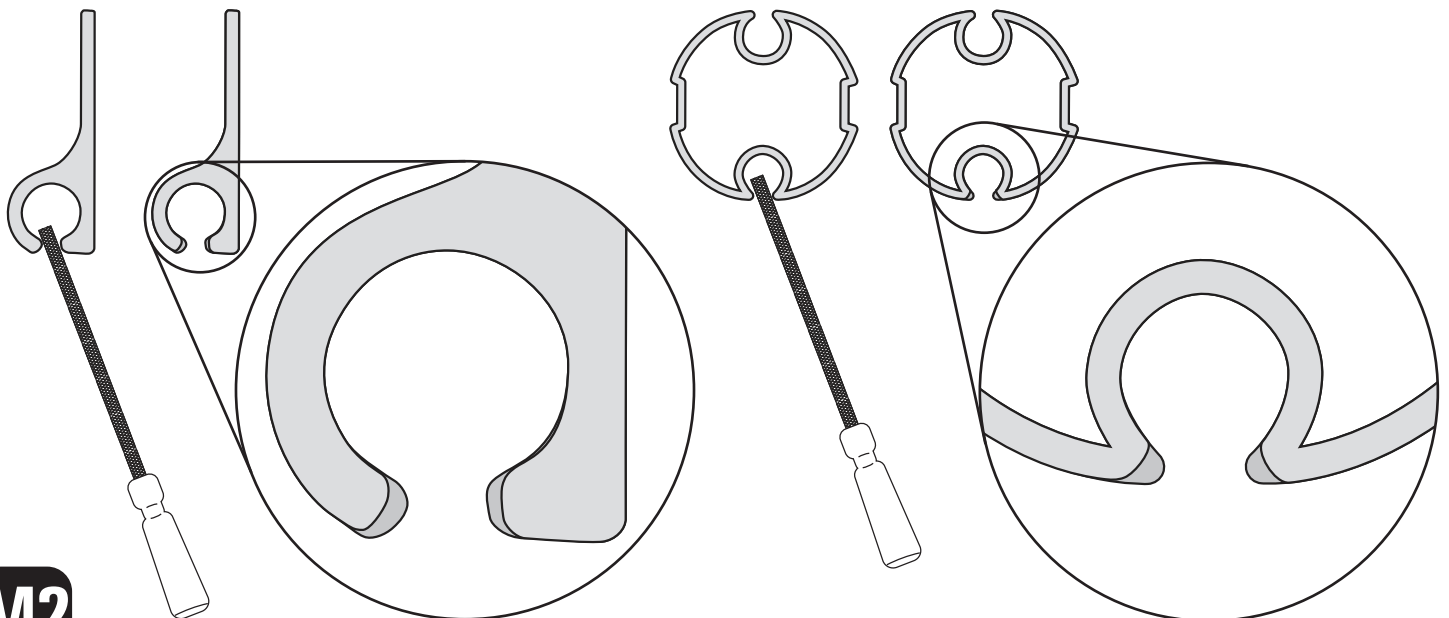

M2

Insert curtain keder into either tack strip or roll tube curtain track as shown. Guide curtain along entire length of opening.

TIP: Elevating and feeding curtain into track opening will ease installation.

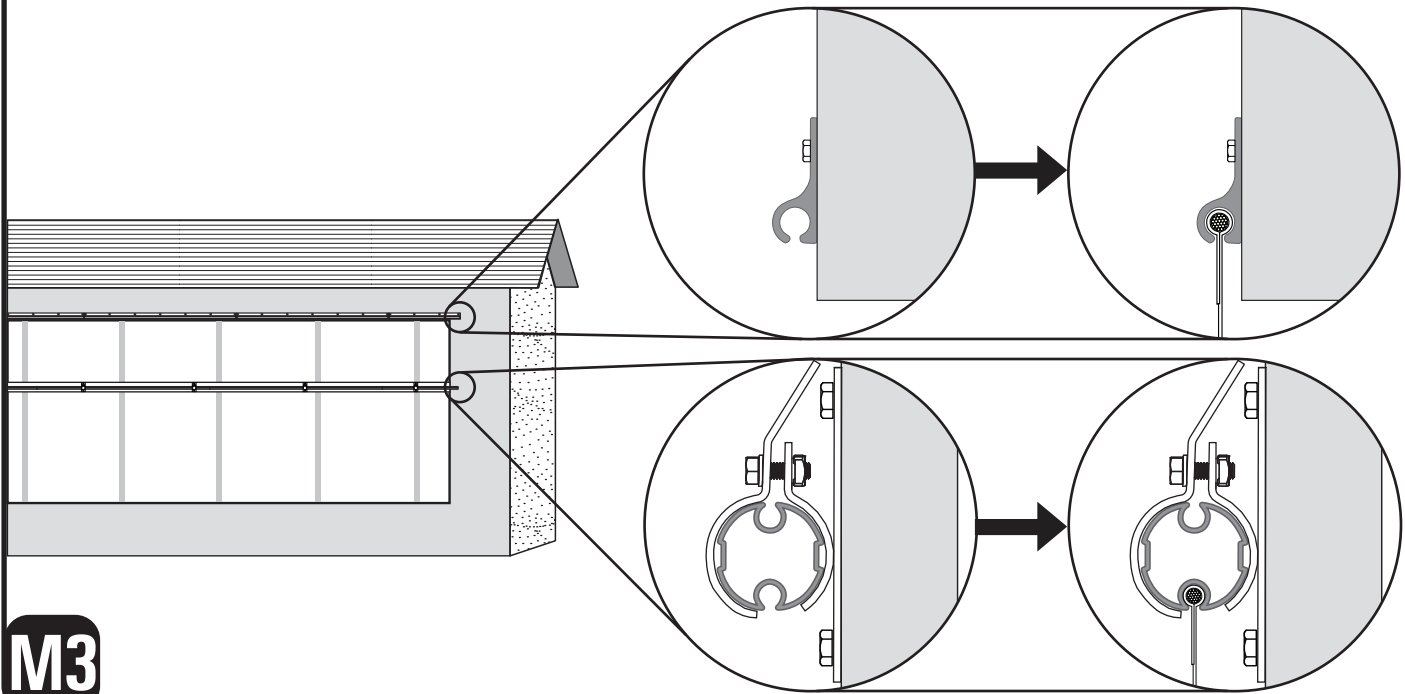

M3

Slide roll tube sections onto bottom curtain keder, connecting roll tubes as you go using splice and **required** (8) #10 x 1" square head Tek Screws (**any damage caused by improper assembly of splice and its hardware will not be covered by warranty**). Use marks made in **Section K** as your guide for placement. Roll tubes that do not connect to a drive need to extend a minimum of 3" beyond the opening. For roll tubes that will connect to a drive, refer to marks drawn in **Step H2** for end drive installation or for center drive installation refer to **Step G3** if using powered drive, if only using manual drive/s refer to **Step G4**.

For a Middle Roll curtain, repeat **Step M1** or **Step M2** to hang bottom half of curtain and finish with another roll tube.

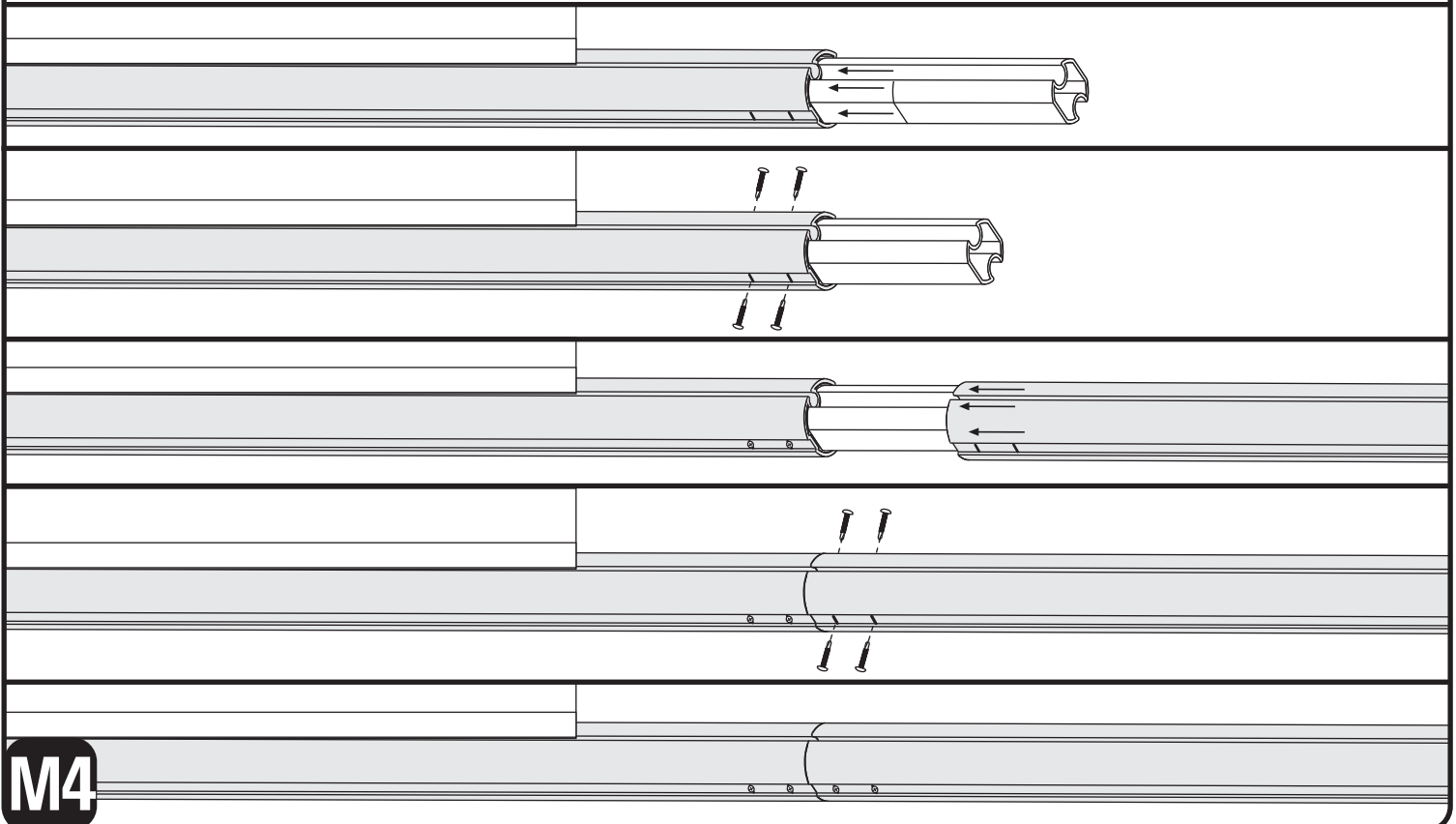

M4

Bottom Roll

Top secured with Tack Strip

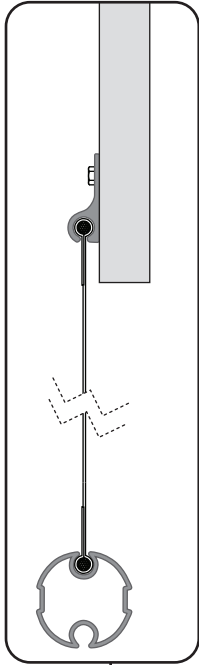

Top secured with Roll Tube

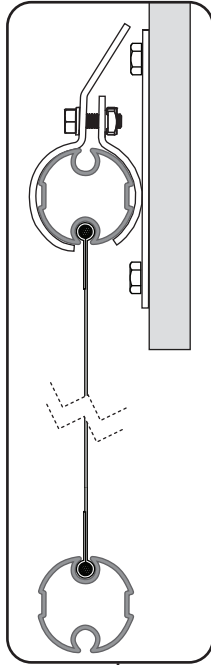

Middle Roll

Top secured with Tack Strip

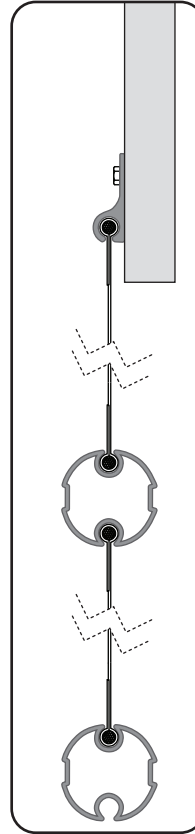

Top secured with Roll Tube

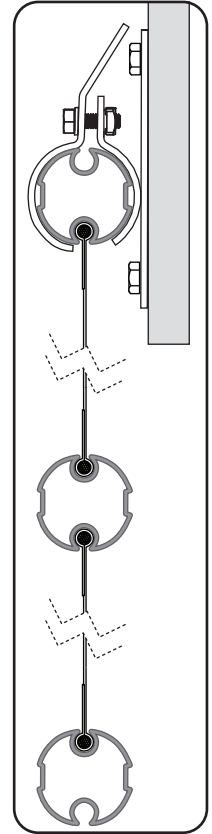

Two Tier

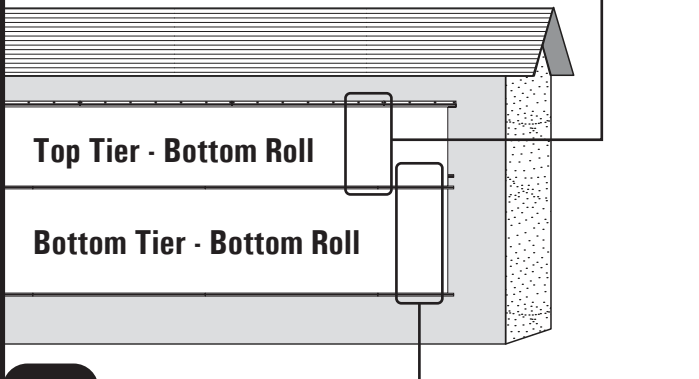

Two Tier

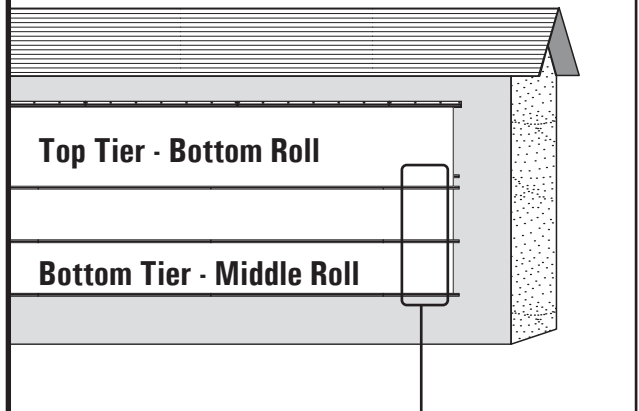

It is important that when the curtain is closed the roll tube **MUST** rest **BELOW** the roll tube or tack strip that secures the curtain below it.

NOTE: Damage to curtain material caused by abrading is not covered by warranty. Once curtain is installed occasional inspection of the curtain material for areas of wear and abrasion is recommended.

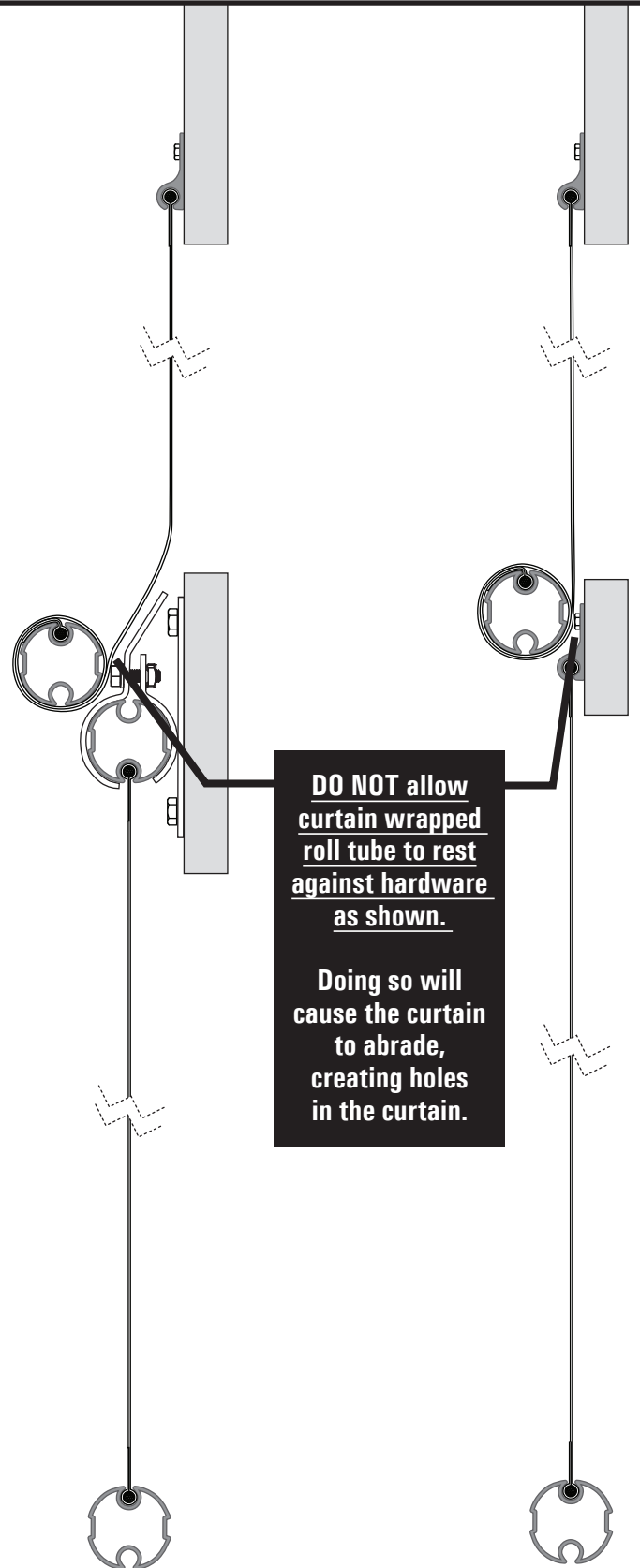
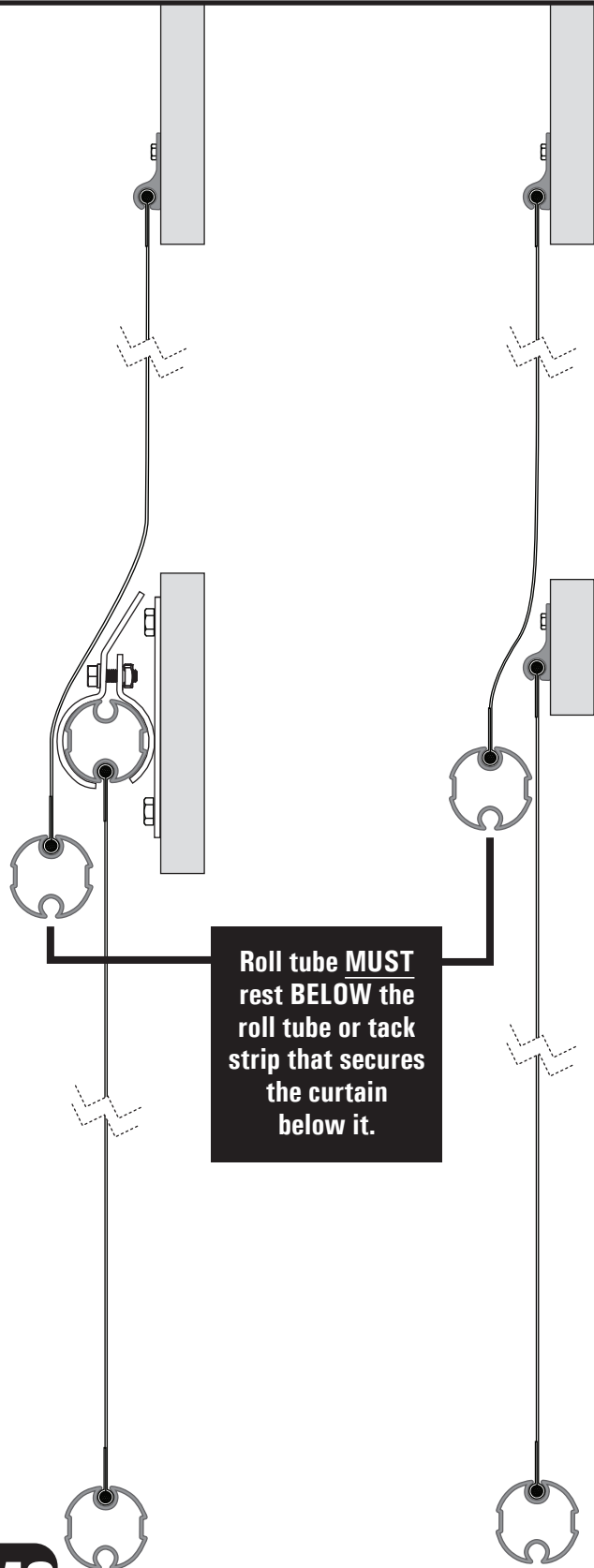

M6

All square, round and rectangular standard rigid wind pipe mounting brackets are secured to the structure in the same manner, including recommended spacing.

If installing rigid wind pipe with the universal adjustable bracket, skip to [Section O](#).

If installing wind strap system, proceed to [Section P](#).

Start measuring from the edge of the top curtain holder (either tack strip or roll tube) and mark 6' increments (or as designed by J&D representative). 6' is the standard rigid wind pipe spacing. It is strongly recommended not to space them further apart. If location of curtain experiences frequent high winds, you will need to reduce spacing.

N1

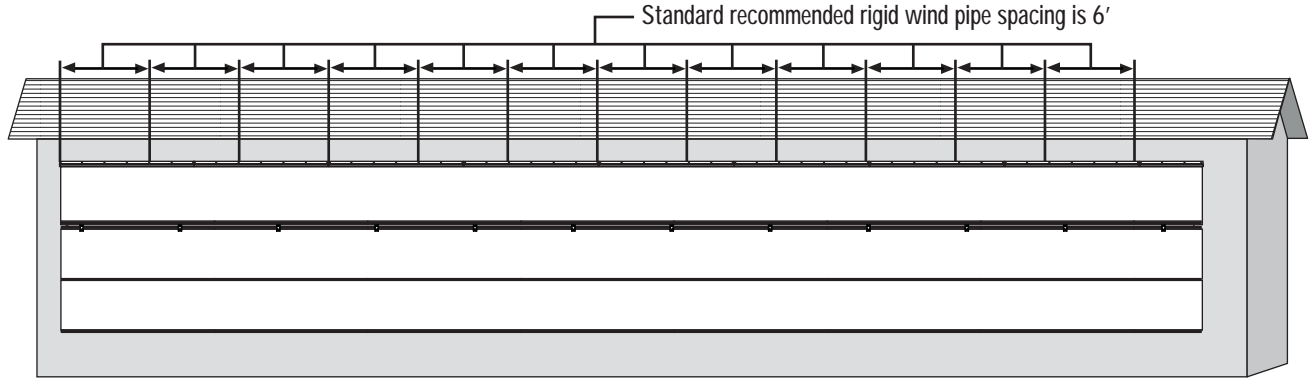

Using the markings made in [Step N1](#) as your guide, install the top wind pipe bracket so the bottom edge of the bracket is 0-2" above the curtain holder, 2" is recommended. Using a level for vertical placement secure each bracket using (2) fasteners specific to your building type (refer to [Section B - Page #1](#) for hardware installation specifications).

N2

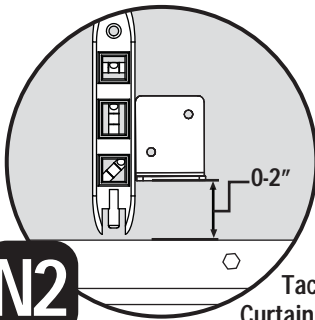
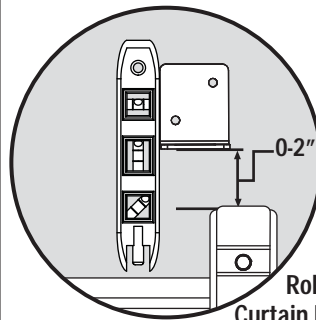
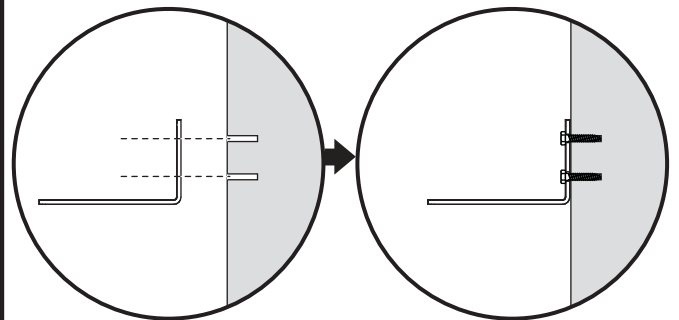
Tack Strip
Curtain HolderRoll Tube
Curtain Holder

Once all the top wind pipe brackets are mounted, use a Plumb Bob to mark the correlating position for the bottom wind pipe bracket. Install bottom wind pipe bracket 6" from the bottom of the curtain opening. Using a level for vertical placement secure each bracket using (2) fasteners specific to your building type (refer to [Section B - Page #1](#) for hardware installation specifications).

N3

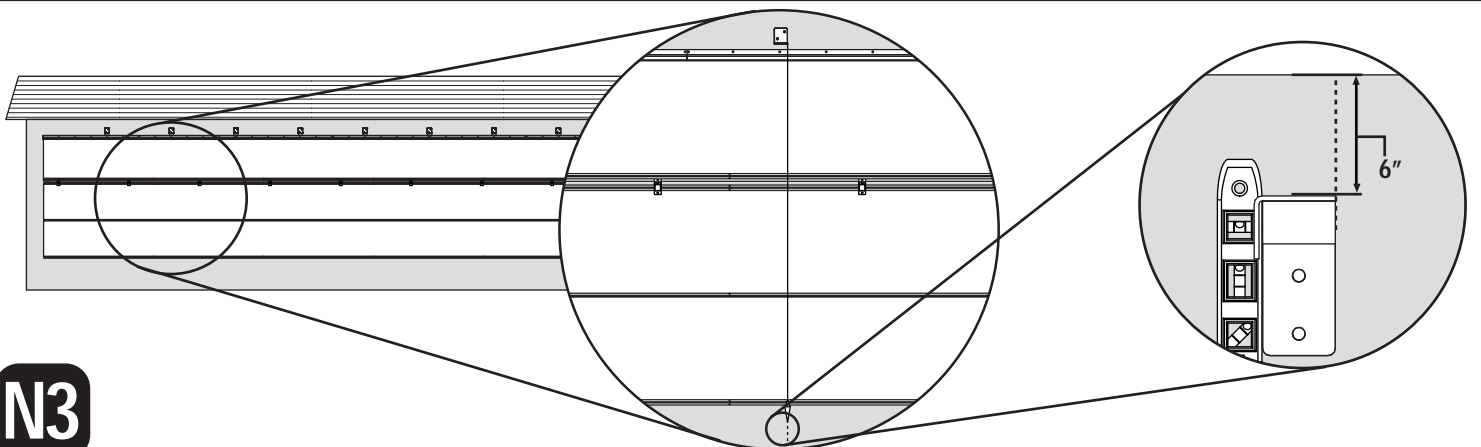

If installing square or round tube wind pipe brackets, skip to [Step N5](#).

If rectangular wind pipe requires trimming, do so before installing rubber cushion. Prepare rectangular wind pipes for installation by sliding rubber cushion into channel as shown below. Trim rubber cushion flush to ends of wind pipe. Secure cushion by driving (1) #10 x1" Square Head Tek Screw through rubber cushion and into back of channel about 1/2" from the top of wind pipe, screw will need to compress rubber cushion to allow passage through bracket opening.

Tip: If the rubber cushion is difficult to slide down channel, fill bucket with warm water and small amount of mild dish soap, dip cushion in bucket of warm soapy water to lubricate it.

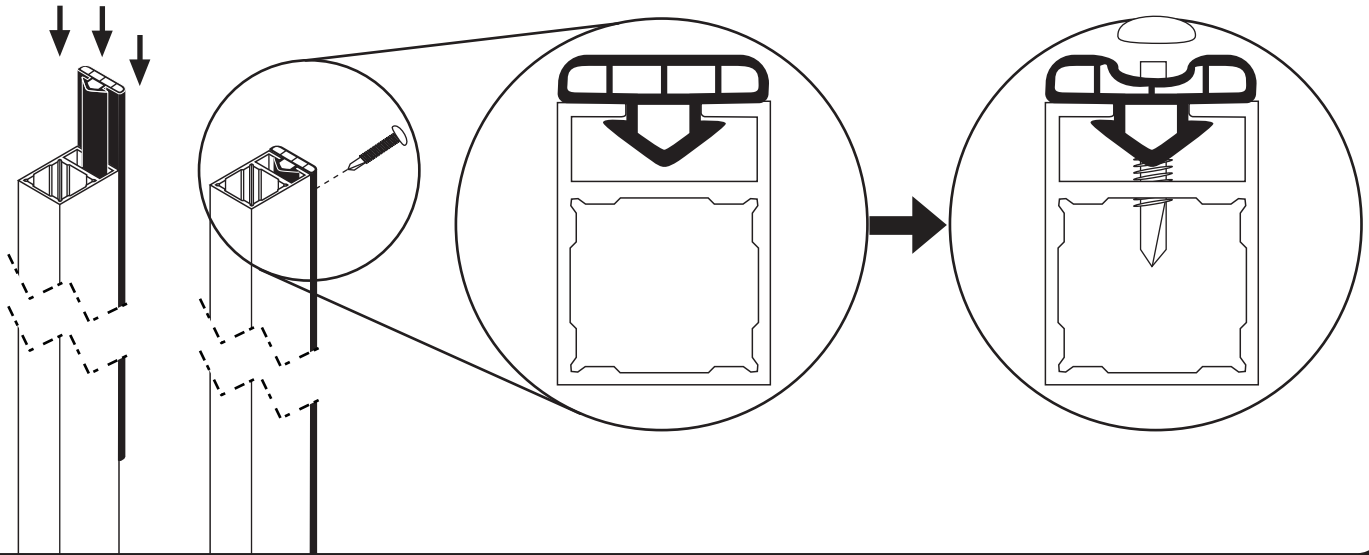

N4

Once top and bottom brackets are installed, insert the wind pipe into the brackets. The wind pipe should extend at least 4" beyond each bracket. Using (1) 1/4"-14 x 1-1/4" Hex Head Tek Screw secure the wind pipe to the bottom bracket.

Tip: When installing windpipe use the bracket slot combination that allows for unhindered curtain movement when opening and closing but minimizes back and forth movement caused by winds.

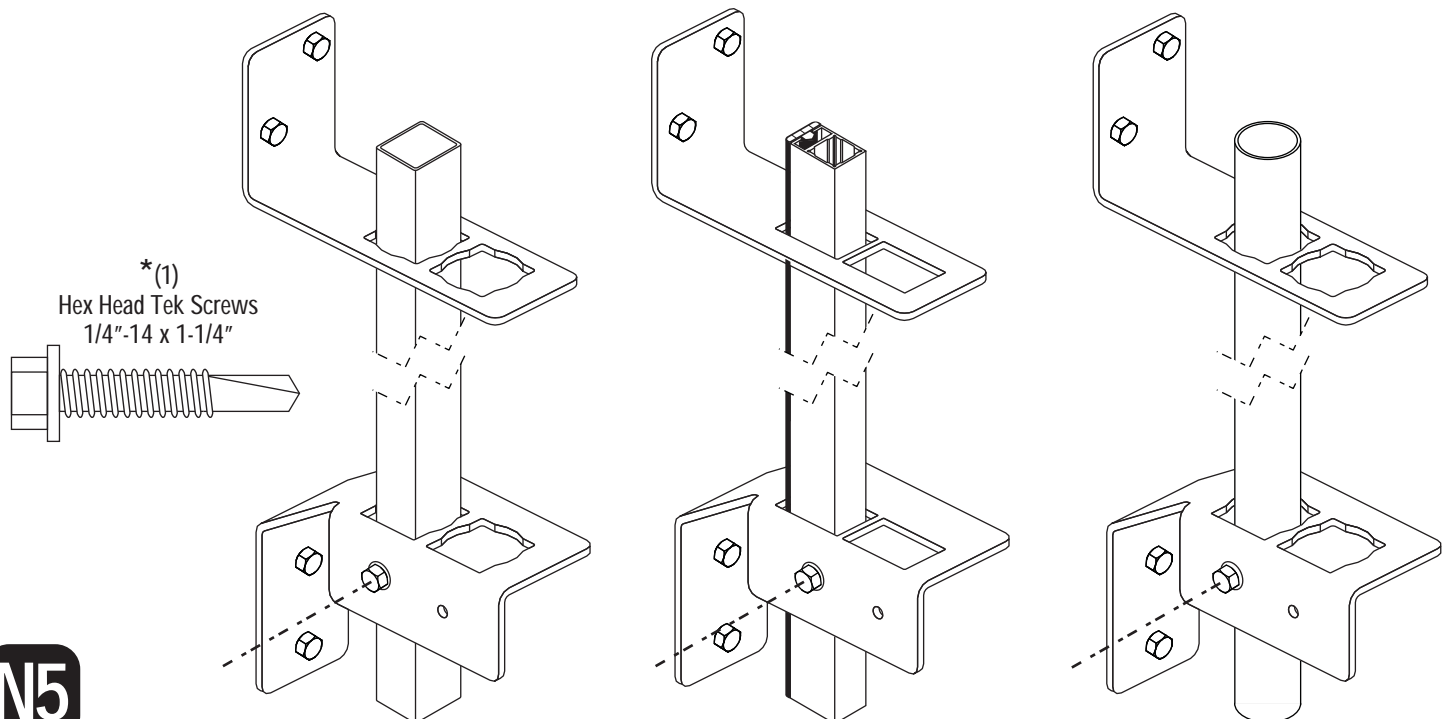

N5

Proceed to [Section Q](#) for stretching curtain.

Start measuring from the edge of the top curtain holder (either tack strip or roll tube) and mark 6' increments (or as designed by J&D representative) for the standard rigid wind pipe spacing. It is strongly recommended not to space them further apart. If location of curtain experiences frequent high winds, you will need to reduce spacing.

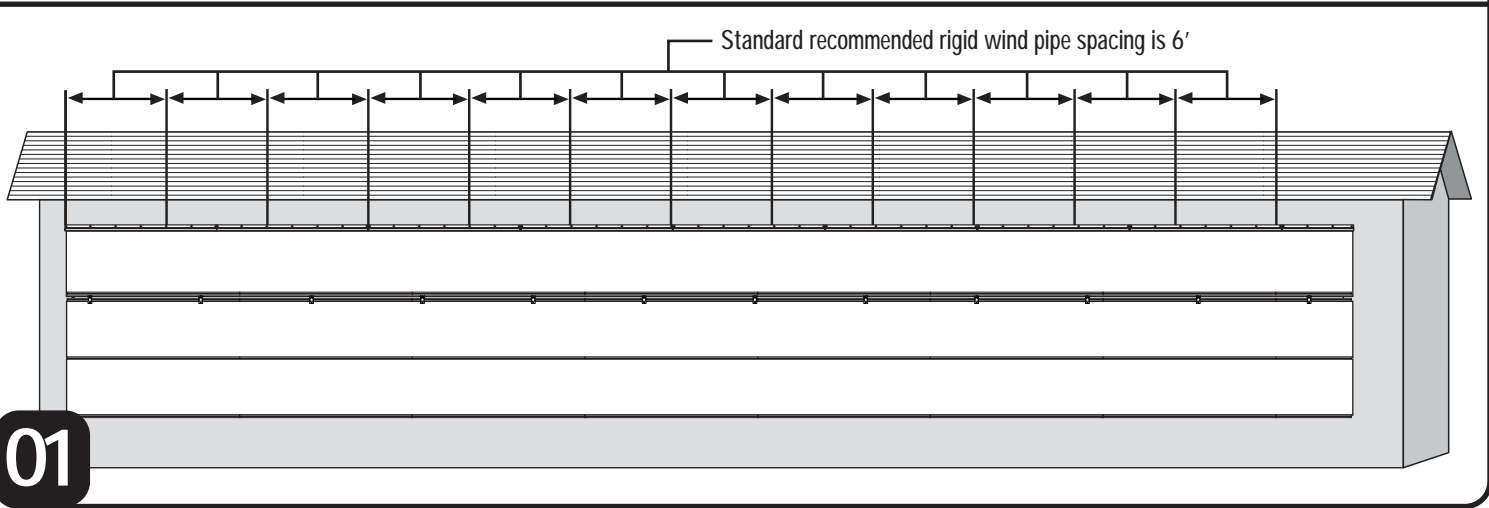

Using the markings made in **Step 01** as your guide, install the top universal adjustable wind pipe bracket so the bottom edge of the bracket is 0-2" above the curtain holder, 2" is recommended. Using a level for vertical placement secure each bracket using (2) fasteners specific to your building type (refer to **Section B - Page #1** for hardware installation specifications).

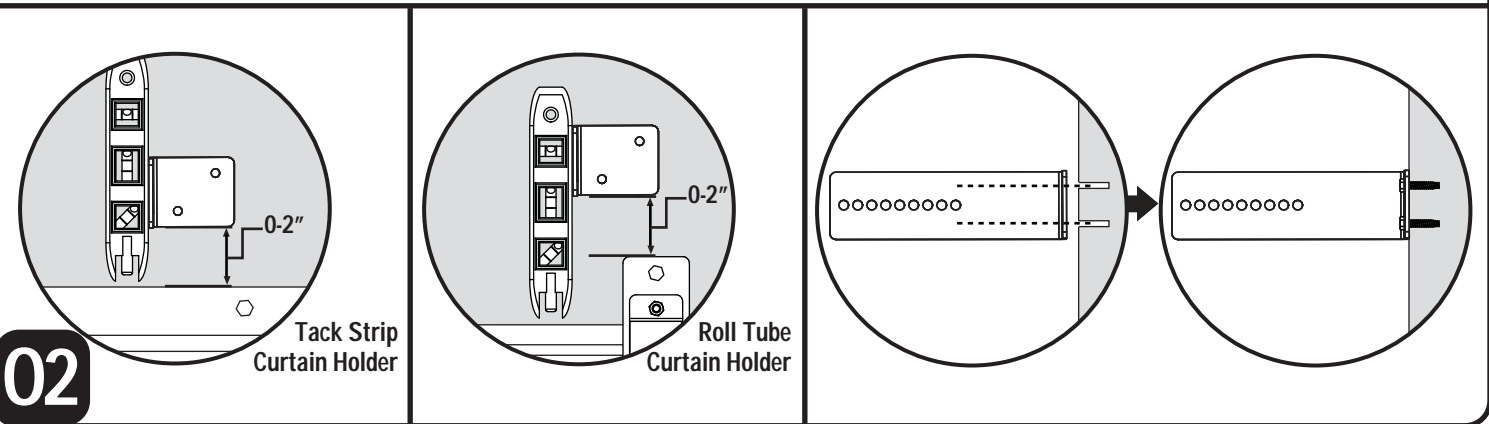

Once all the top wind pipe brackets are mounted, use a Plumb Bob to mark the correlating position for the bottom wind pipe bracket. Install bottom universal adjustable wind pipe bracket 6" from the bottom of the curtain opening. Using a level for vertical placement secure each bracket using (2) fasteners specific to your building type (refer to **Section B - Page #1** for hardware installation specifications).

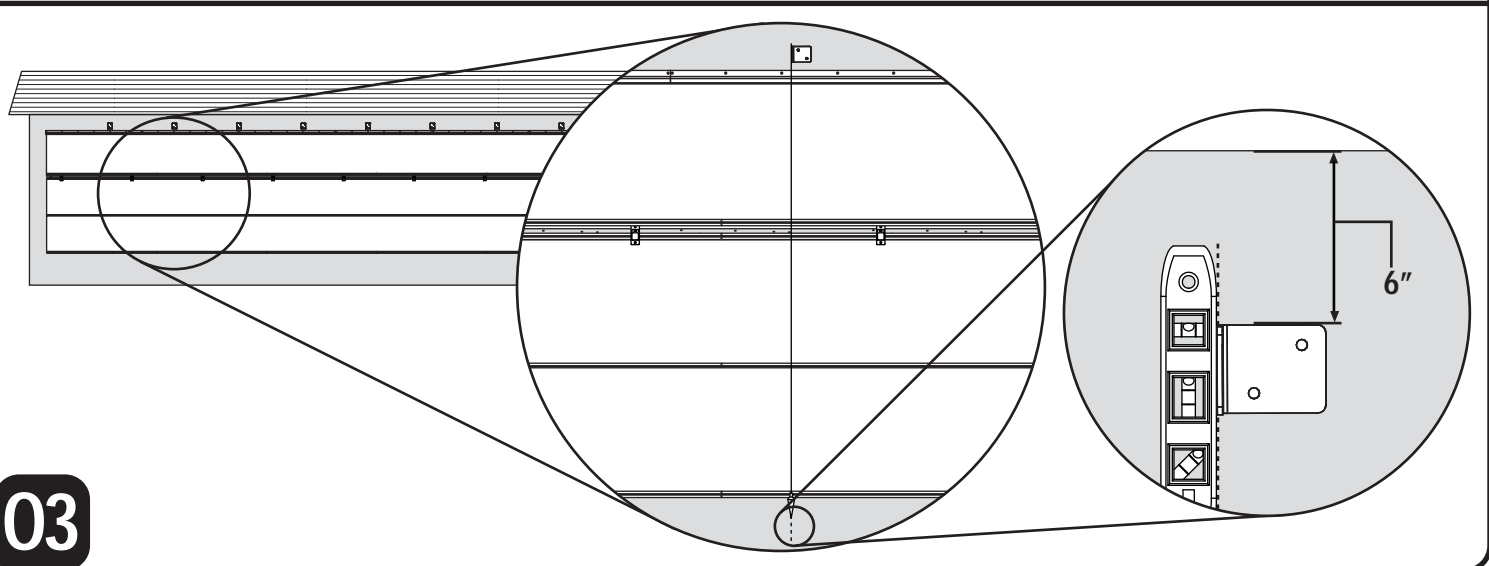

Select a distance for the gap between curtain and rigid wind pipe. Remember to take into consideration the increased diameter of the rolled curtain when fully open. You do not want the curtain contacting the wind pipe when at rest. Once the distance has been determined, insert (1) 1/4"-20 x 2-1/2" Carriage Bolt into each of the side plates. The "L" shaped plate is for the bottom bracket. Insert the Carriage Bolt through the hole in the mounted bracket that corresponds with your desired spacing. Lightly affix (1) 1/4"-20 Nylock Nut to each bolt. Insert the desired square, round or rectangular rigid wind pipe until it is flush against the installed bolt. Rest the bottom of the wind pipe on the platform of the "L" plate as shown below. Insert (1) 1/4"-20 x 2-1/2" Carriage Bolt into each of the side plates, and then through the corresponding hole in the mounted bracket to provide a snug fit around the rigid wind pipe. Affix (1) 1/4"-20 Nylock Nut to each bolt. Tighten all nuts to fully secure the rigid wind pipe.

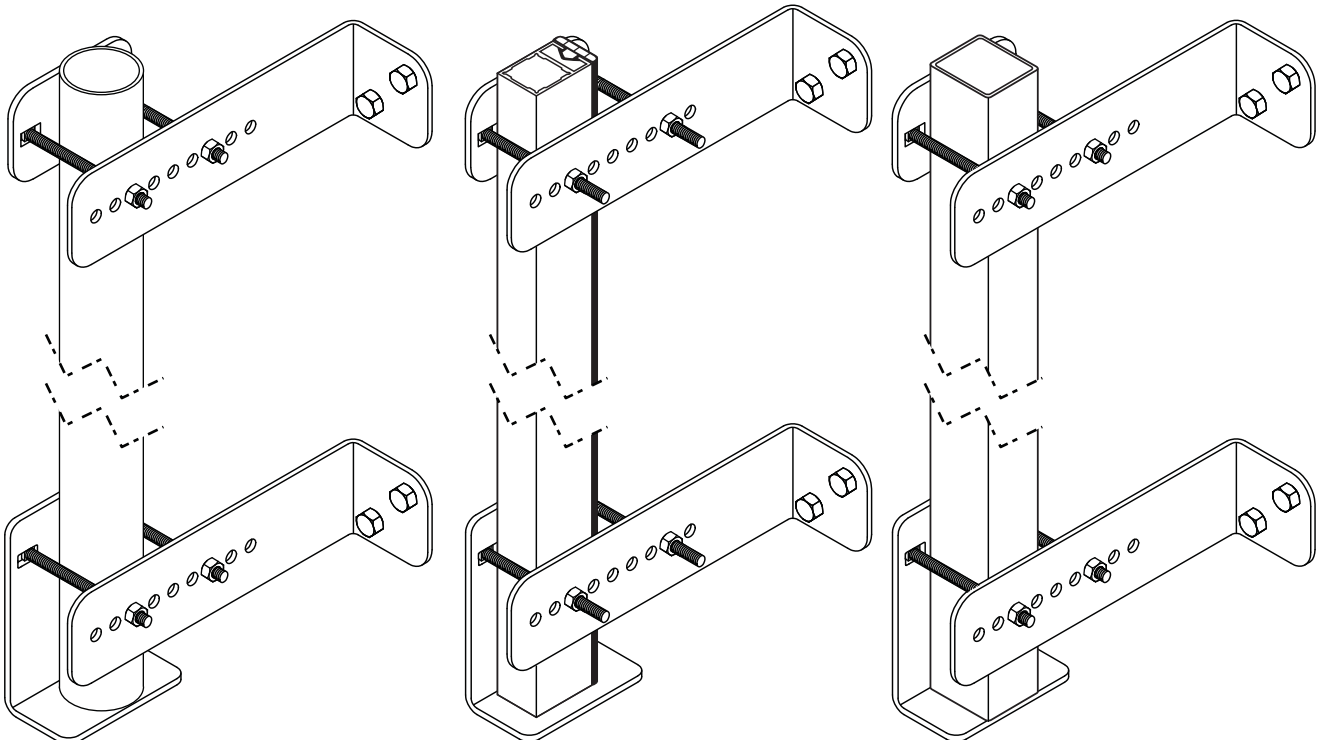
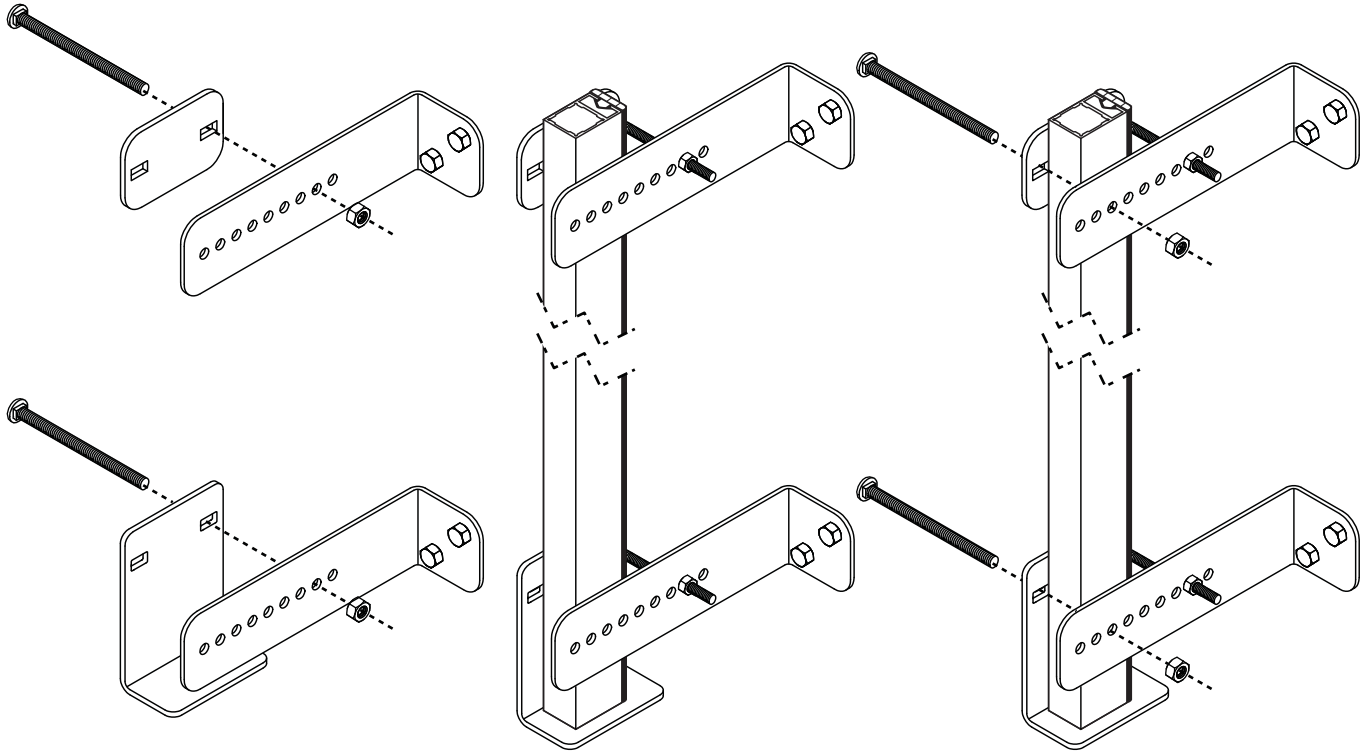

04

Proceed to [Section Q](#) for stretching curtain.

IMPORTANT! If installing a wind strap system, you cannot use a tack strip for hanging your curtain. All curtain sections must be hung using roll tubes and roll tube mounting brackets.

Start measuring from the edge of the bottom roll tube. Make a mark every 5' for the standard wind strap spacing (or as designed by J&D representative). It is strongly recommended not to space them further apart. If location of curtain experiences frequent high winds, you will need to reduce spacing.

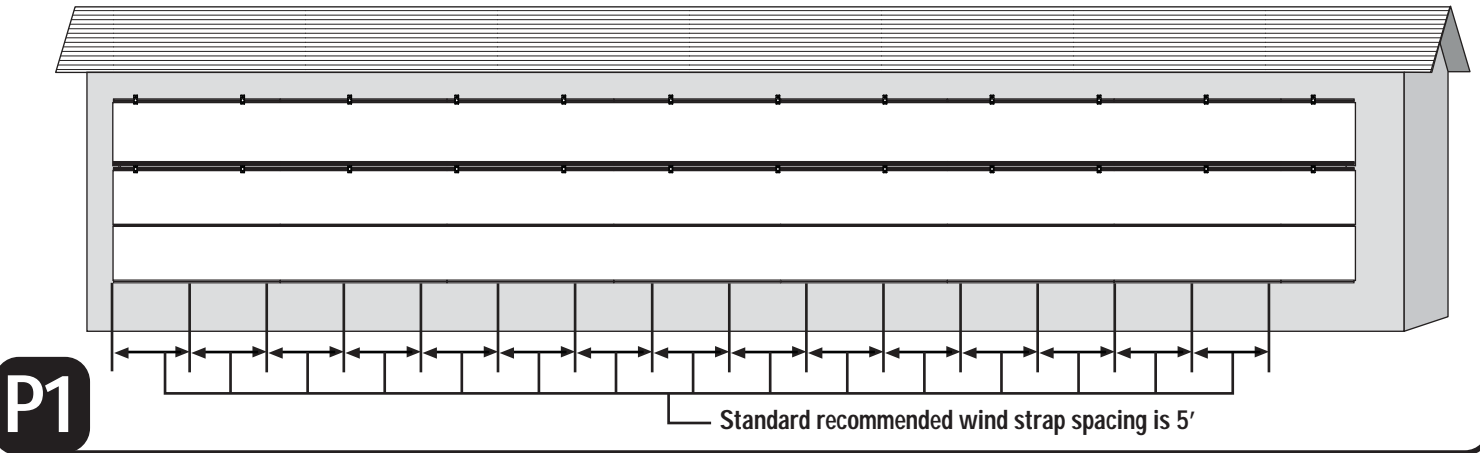

Using the markings made in **Step P1** as your guide, install the curtain wind strap winch, wind strap webbing and poly wind strap protector with the top of the winch placed 2-4" below the bottom roll tube when curtain is completely unrolled. Using a level for vertical placement secure each bracket using (2) fasteners specific to your building type (refer to **Section B - Page #1** for hardware installation specifications), as shown in *Figure A* below. Once assembly is securely mounted, thread the strap through the slot in the poly wind strap protector as shown in *Figure B*. Mark the placement of the top bracket. Top bracket should be mounted directly above the wind strap winch, and 4" above the top curtain holder roll tube. Secure each bracket using (2) fasteners specific to your building type (refer to **Section B - Page #1** for hardware installation specifications).

Once the top wind strap bracket is secured, thread wind strap behind curtain, between curtain roll tubes and structure, and then behind the top wind strap bracket. Bring wind strap over to the front of the top bracket as shown in *Figure C*, and in front of curtains until you reach the winch. Make one twist in wind strap as shown in *Figure D*. Measure wind strap 1' past winch and trim wind strap. Feed the end of wind strap into winch strap slot. Hold end of strap in slot and hand turn gear knob until strap is snug as shown in *Figure E*. Do not over tighten strap. If you can pluck the strap and it makes noise, it is too tight.

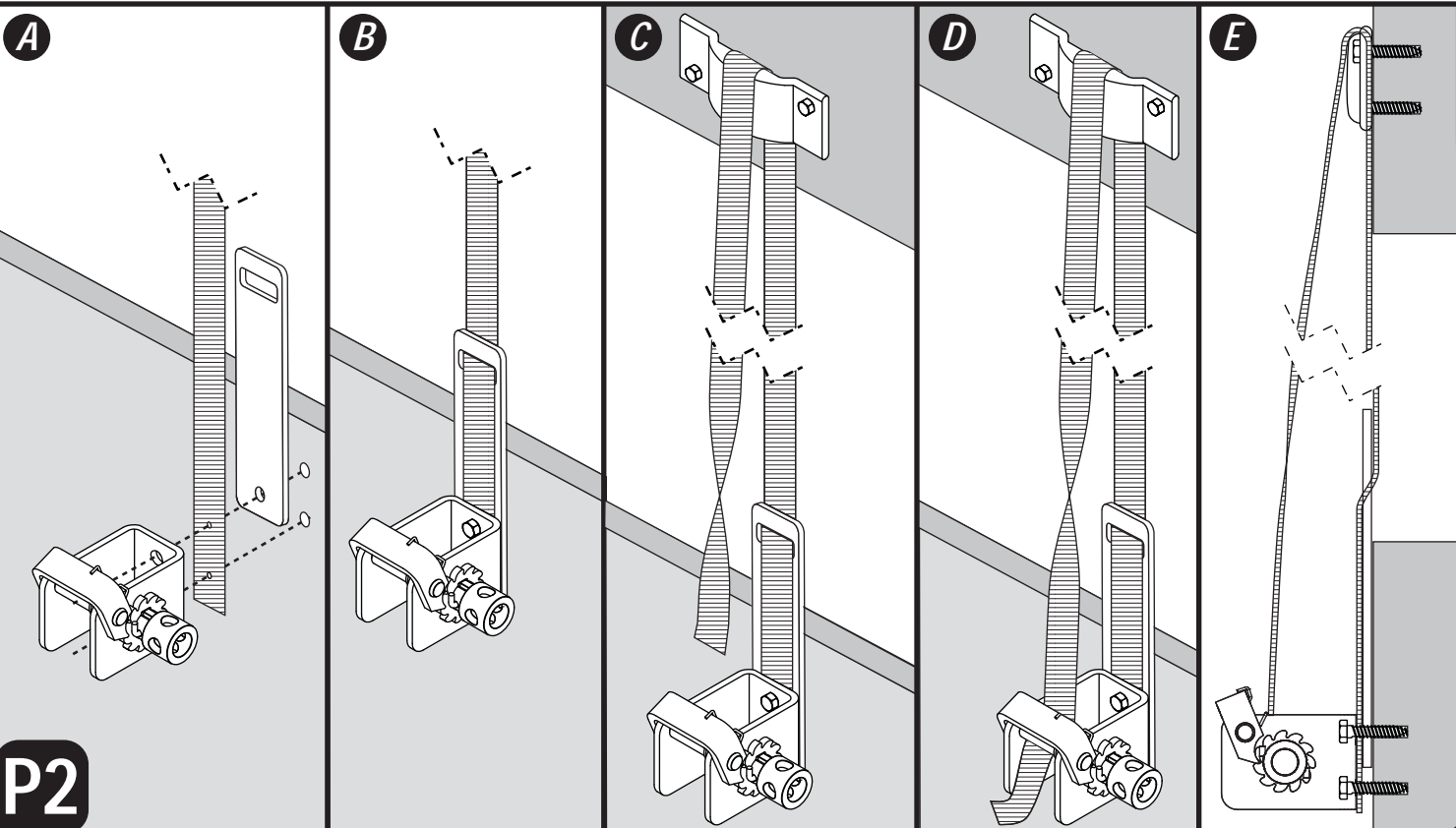

IMPORTANT!

When stretching curtain, only use 100-150 lbs of in line pulling force. Using more than 150 lbs could cause tearing or weakening of the curtain and will void the warranty.

If you are installing a length of curtain under 120', proceed to [Step Q2](#).

Once all of the curtains are hung and wind restraints are installed, prep all the curtains for stretching by securing the center of each curtain to its tack strip or roll tube assembly using (1) #10 x 1" square head Tek Screw as shown below.

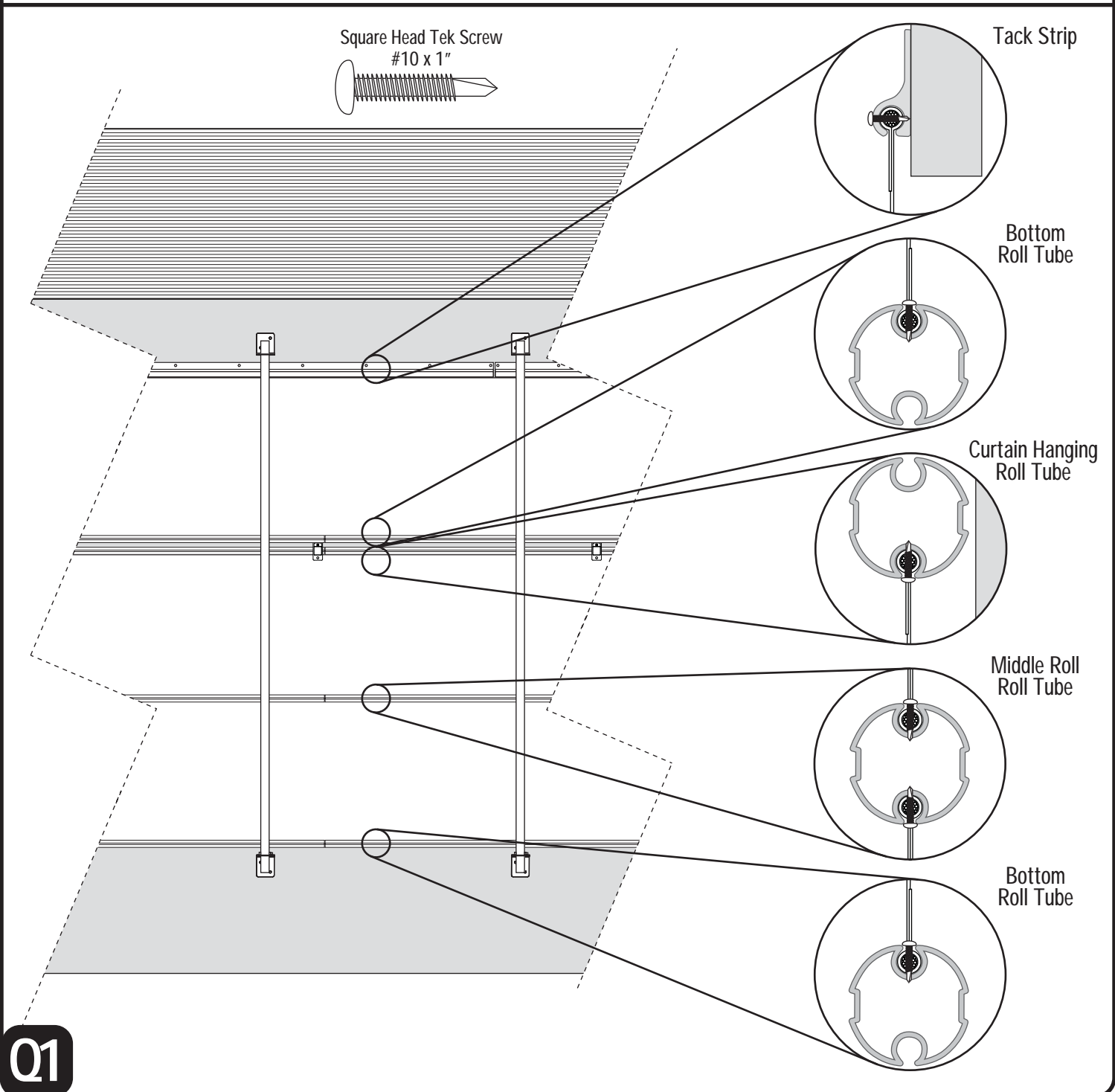

Proceed to [Step Q3](#) and stretch the curtain/s each side of the screw secured in [Step Q1](#).

Once all of the curtains are hung and wind restraints are installed, prep all the curtains for stretching by securing the drive end of each curtain 1" from end of tack strip installation or roll tube assembly using (1) #10 x 1" square head Tek Screw as shown below.

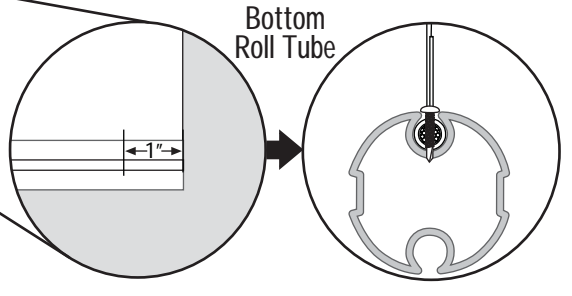
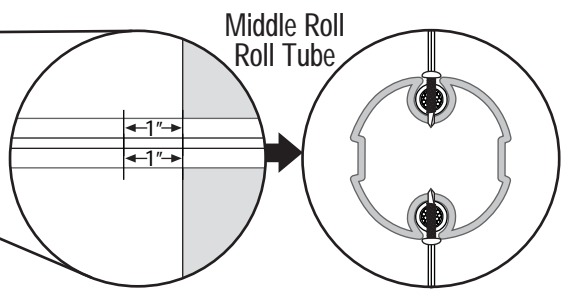
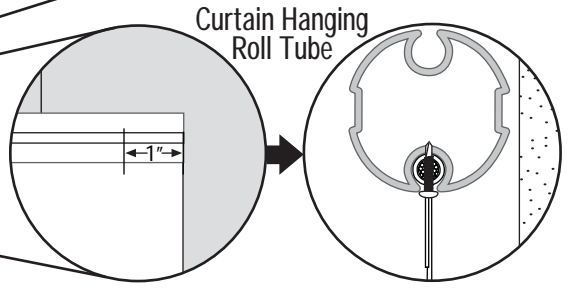
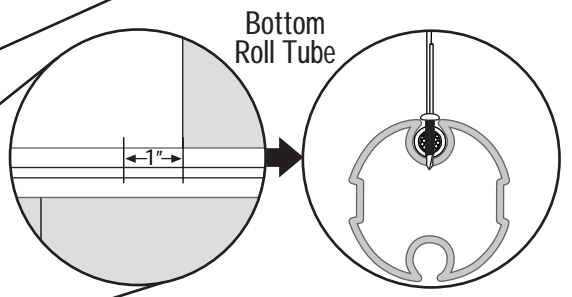
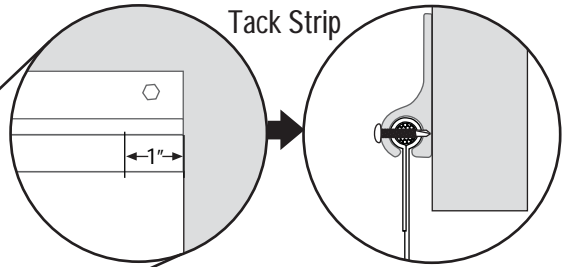
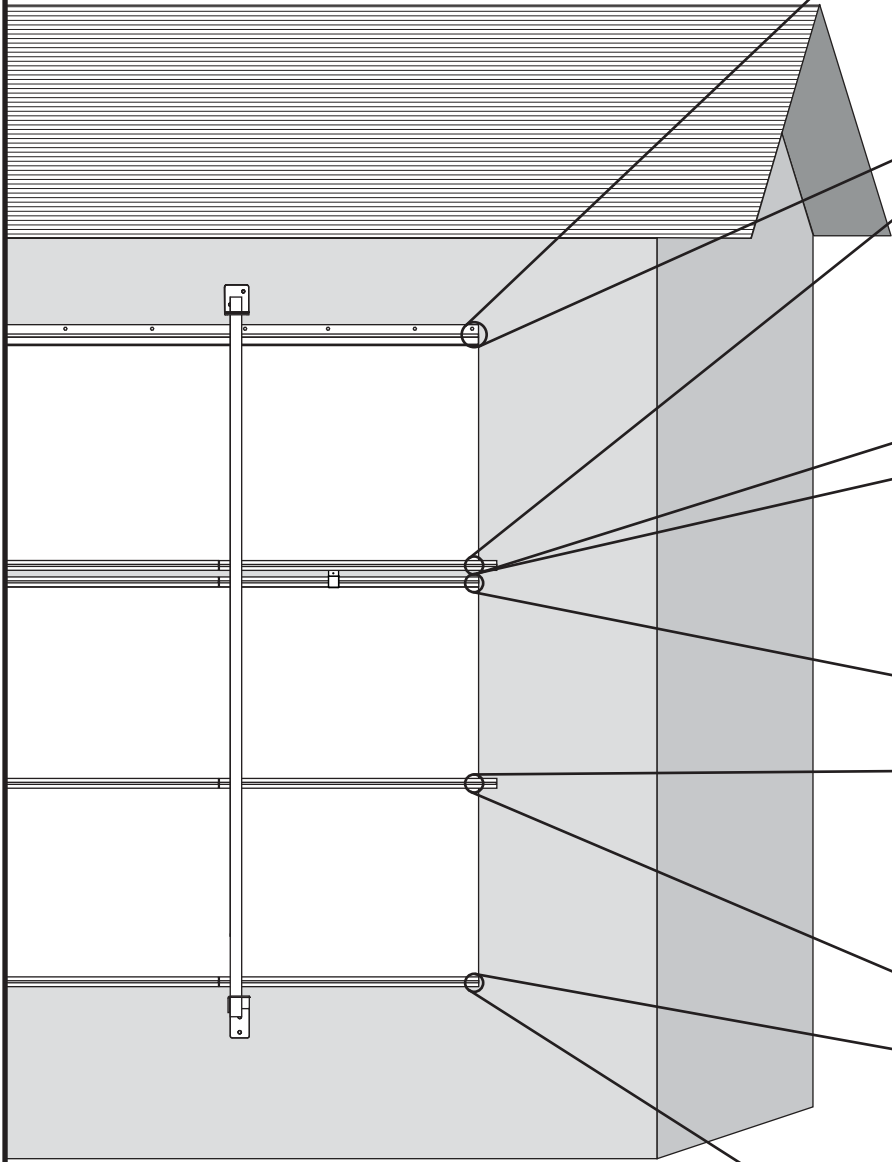
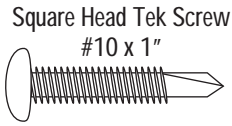

Q2

Make mark on top tack strip or roll tube and on bottom roll tube 2' from edge of dead end curtain. Carry marks over to the curtain. These marks will help verify the amount stretched and assist in visually equalizing the amount stretched on both top and bottom of curtain.

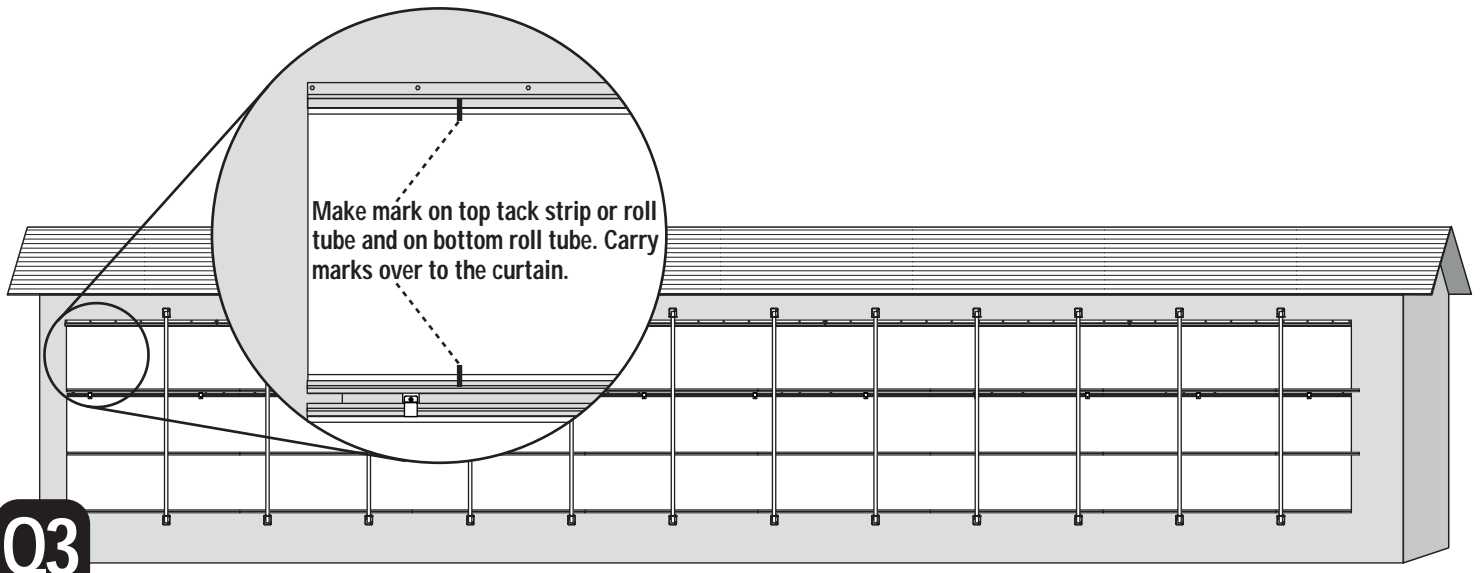

NOTE: PCSR498 Curtain Stretching Tool is optional, not supplied, and purchased separately.

If you are installing a length of curtain over 50', proceed to Step Q5.

Clamp the PCSR498 optional curtain stretching tool firmly to the doubled over heat welded seam of the curtain. DO NOT secure to single thickness of curtain. Remove slack and slowly begin to stretch the curtain using the pulling handle. The amount of stretching that is required is dependent on overall length of curtain. Stretch roughly 1" per 20', using the marks made in Step Q2 as your guide.

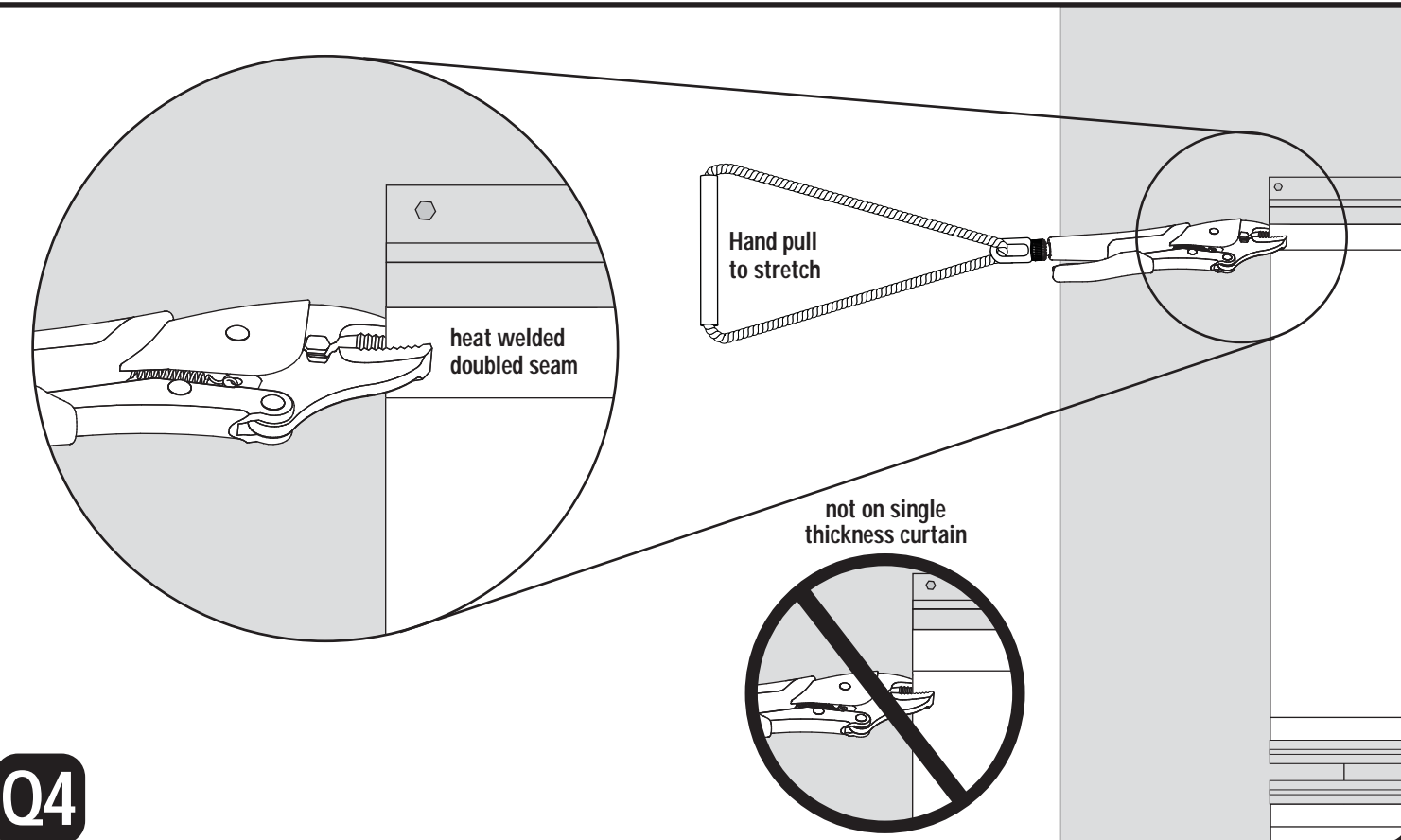

If you are installing a length of curtain under 50', proceed to Step Q6.

Securely anchor wire fence stretcher or winch to immobile object and connect the PCSR498 optional curtain stretching tool to winch part of stretcher. Using the curtain stretching tool, firmly clasp the doubled over heat welded seam of the curtain. DO NOT secure to single thickness of curtain. Proceed to remove slack in stretcher assembly. Once stretcher assembly is taut, slowly begin to stretch the curtain by ratcheting the fence stretcher. The amount of stretching that is required is dependent on overall length of curtain. Stretch roughly 1" per 20', using the marks made in Step Q2 as your guide.

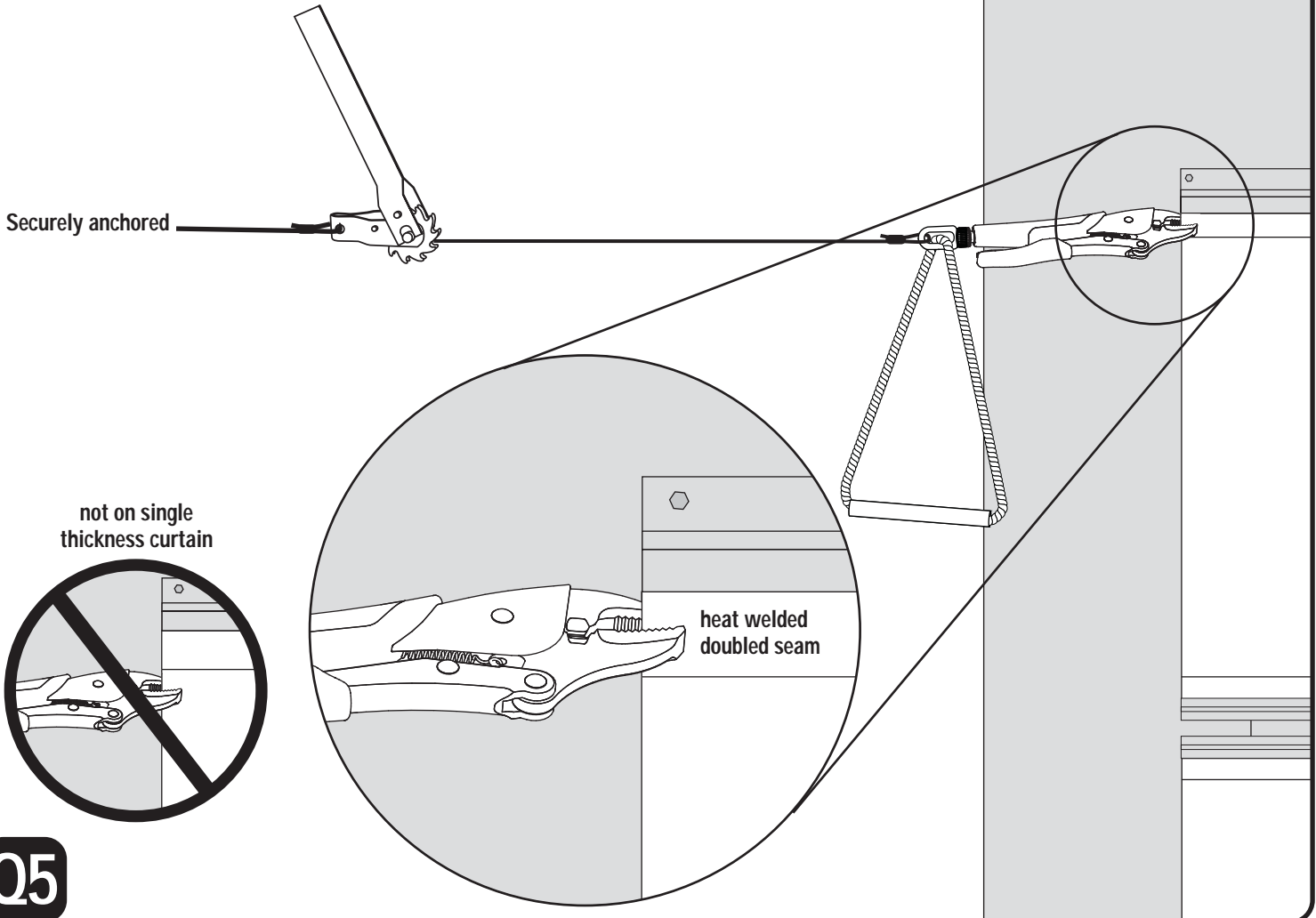

Once the curtain is sufficiently stretched, secure curtain to tack strip or roll tube 1" from end of tack strip or roll tube using (1) #10 x 1" square head Tek Screw as shown below.

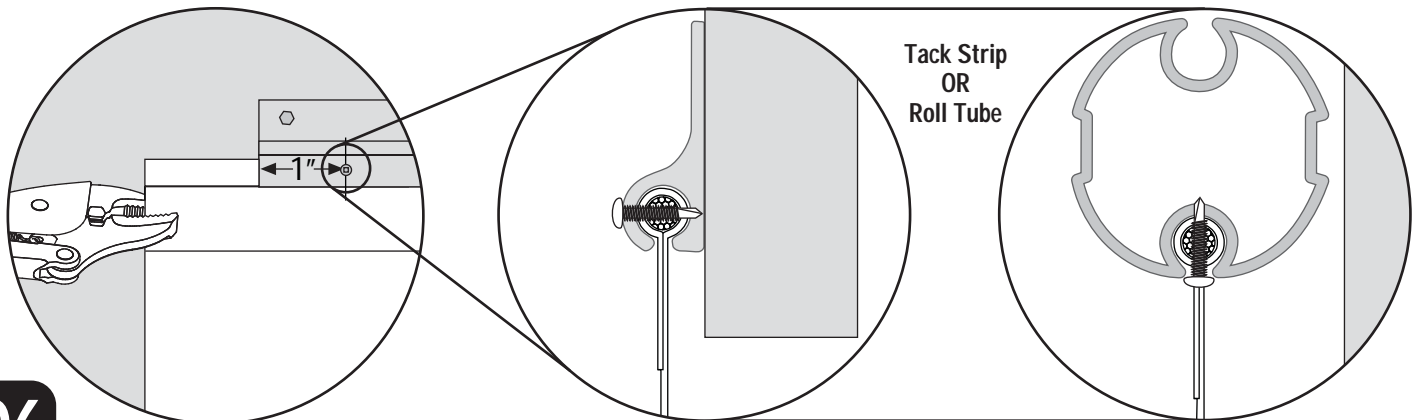

The bottom roll tubes and center roll tubes may need to be temporarily anchored to structure to allow proper stretching.

Repeat this stretching technique on the bottom of the same curtain so that the amount stretched matches on both top and bottom of the curtain. Use the marks made in **Step Q2** as your guide.

not on single thickness curtain



heat welded doubled seam

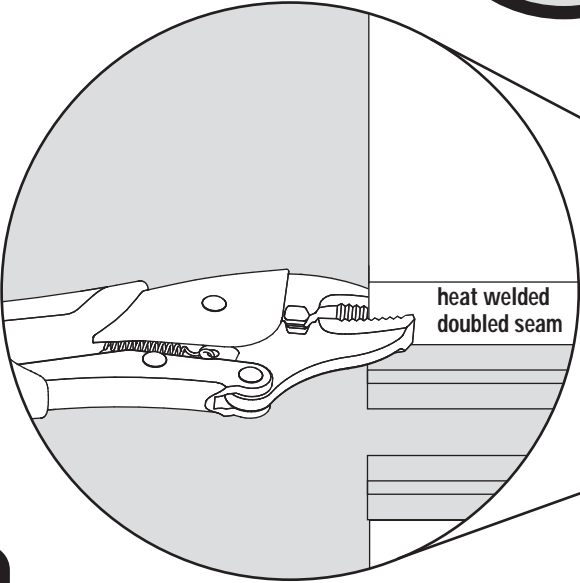

Stretch bottom of curtain to match the amount stretched on top of curtain

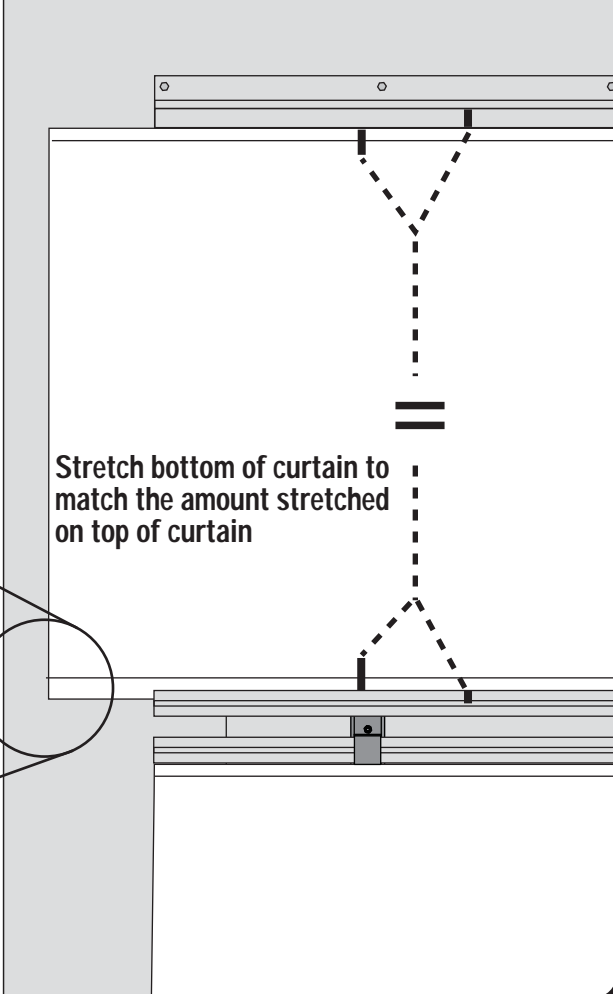

Q7

Once the bottom of the curtain is sufficiently stretched, secure curtain to roll tube 1" from end of roll tube using (1) #10 x 1" square head Tek Screw.

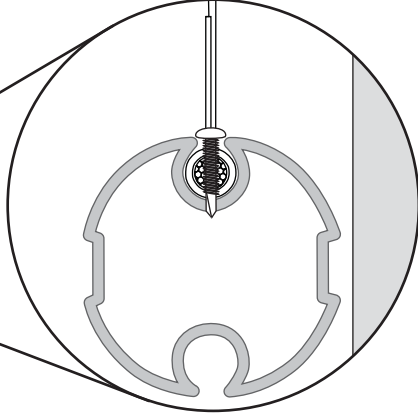
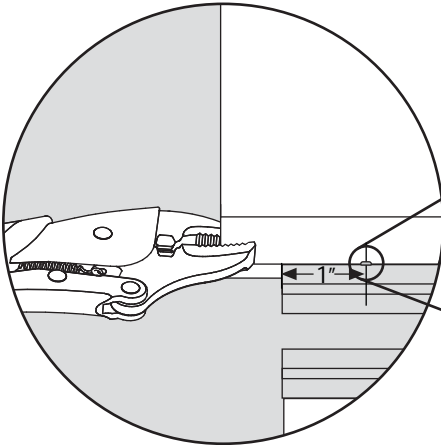

Q8

For multiple curtain installation, repeat **Steps Q2 through Q7** as your system requires.

Once you have stretched the dead end of each curtain, make marks on the drive end as you did in **Step Q2**. Attach the curtain stretching tool securely to the heat welded seam. If you do not have curtain secured with stretching tool before removing screw, it will cause curtain to retreat. Once curtain is secured with tool, remove square head tech screw installed in **Step Q1**. Stretch and secure curtain by following **Steps Q3 through Q7**.

Secure curtain with curtain stretching tool.

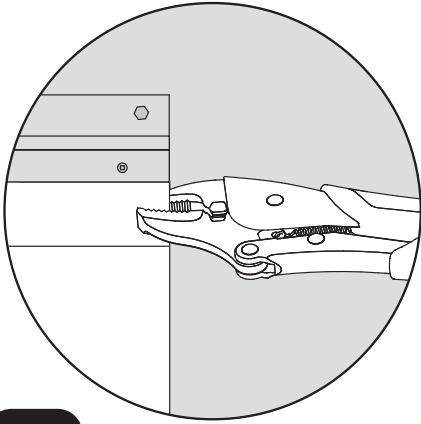

Q9

Remove screw once stretching tool is attached.

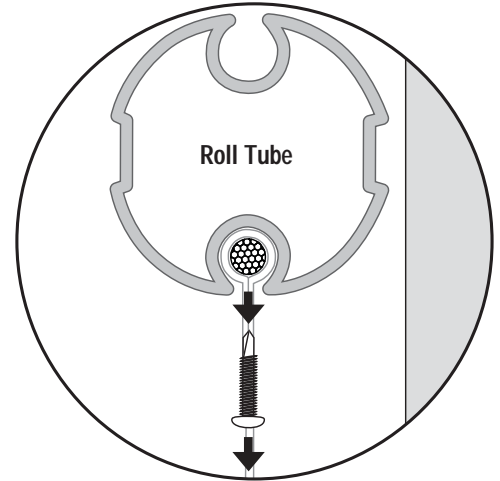
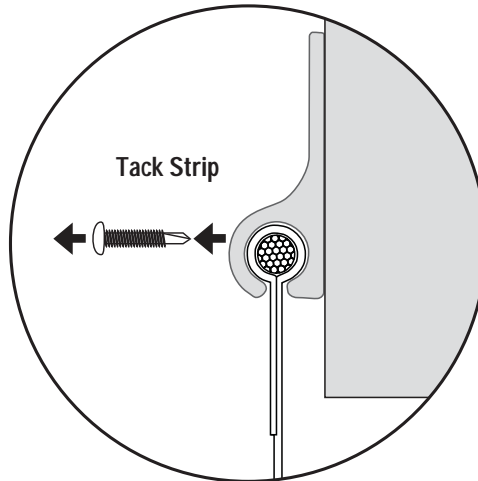

If your curtain is over 120' and you are done stretching and securing the curtain remove screw installed in **Step Q1**.

Once all your curtains are stretched from both sides and secured, step back and examine curtains for waves or uneven stretching.

If your curtain shows waves, you need to further stretch the curtain bottom until these waves flatten.

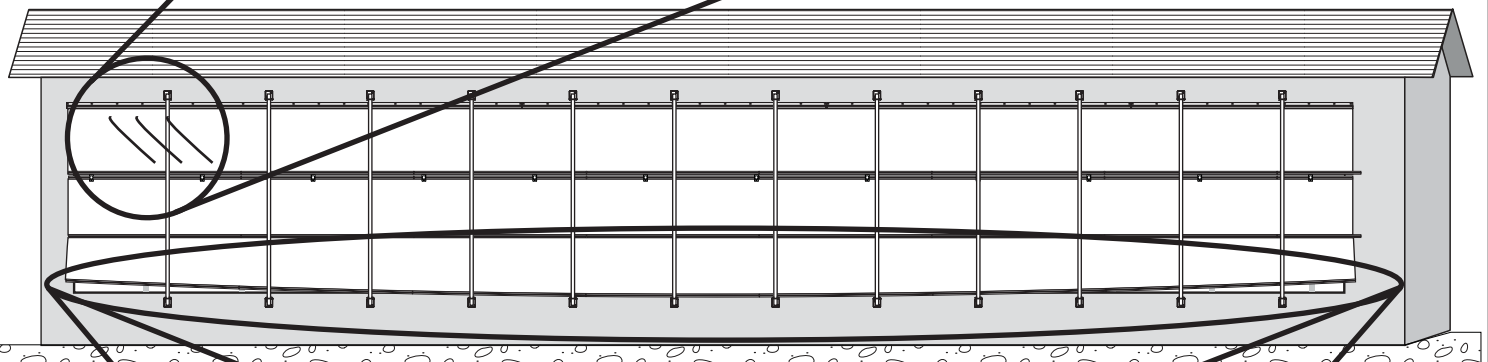

If your bottom curtain curves up on the ends, that means the bottom is pulled too tight. Release the bottom curtain hem by removing the screw and allow the curtain to withdraw until the bottom curtain roll tube returns to a straight and level state. Then re-secure curtain with screw.

Q10

NOTE: If curtain was installed in cold weather it may need to be re-stretched once weather warms - look for signs of uneven rolling or wrinkling

If you are installing only a motorized drive system, proceed to [Section S](#).

Orientation of the PCSR317 Manual Drive and its crank shaft is dependent on the height it will be operated at.

- If operation of Manual Drive will be at 6' or lower, mount unit as shown in [Steps R1 and R2](#).
- If operation of Manual Drive will be above 6', mount unit as shown in [Steps R3 and R4](#).

Orientate the manual drive crank shaft to the climbing bracket as shown. Using the (4) 5/16" x 3-1/2" Hex Bolts and (4) 5/16"-18 Nylock Nuts secure the drive to the bracket using the coordinating mounting holes in the bracket for this drive orientation.

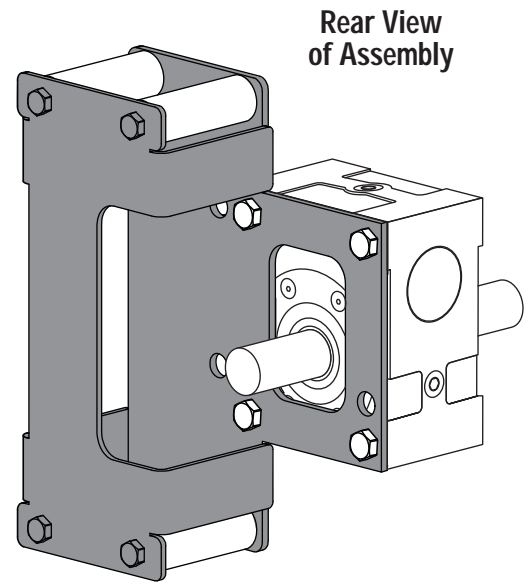
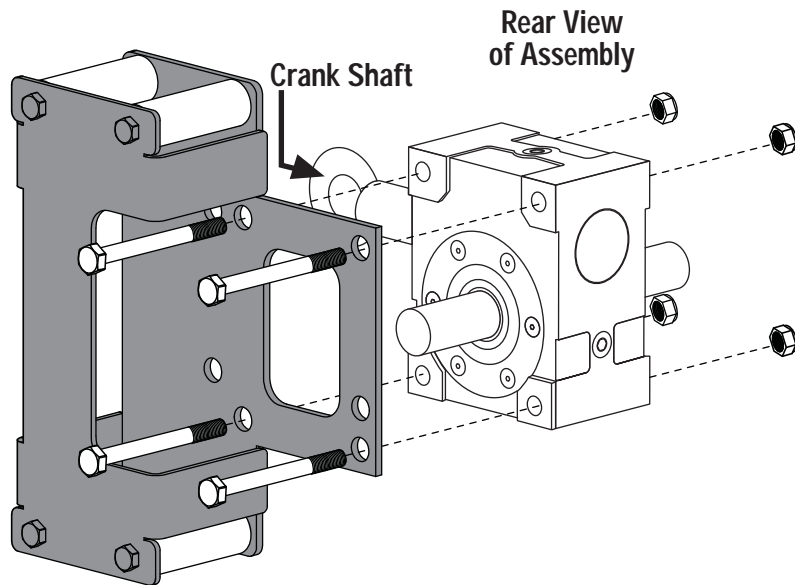

Mark center of climbing bracket. Mark roll tube adapter/s 1" from edge of collar as shown. Slide tube adapter/s onto drive shaft and temporarily secure to shaft by inserting (1) 5/16" x 2-1/2" Hex Bolt through tube adapter collar and shaft hole. Hand tighten (1) 5/16"-18 Nylock Nut to bolt. For end drive systems, install tube adapter to side that is relevant for your system.

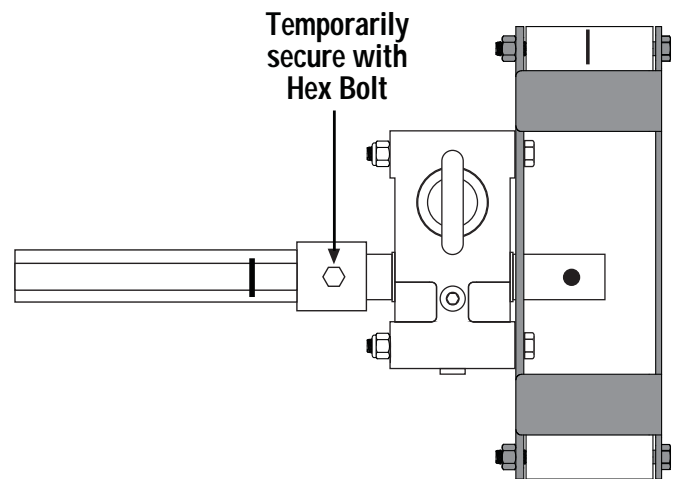
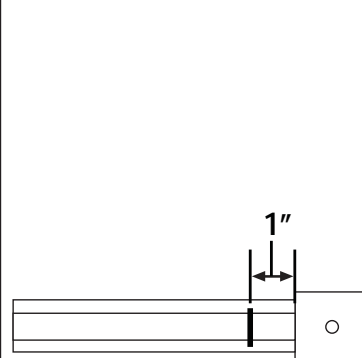
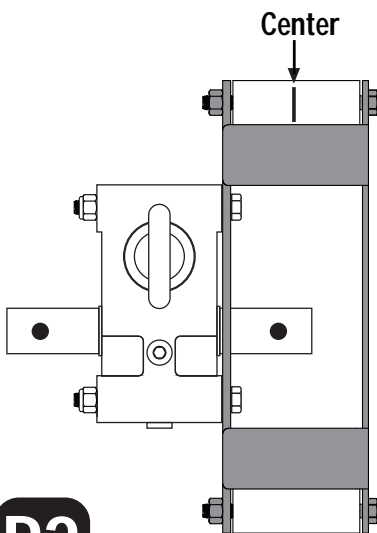

If you are installing only a manual drive system, proceed to [Section T](#).

Orientate the manual drive crank shaft to the climbing bracket as shown. Using the (4) 5/16" x 3-1/2" Hex Bolts and (4) 5/16"-18 Nylock Nuts secure the drive to the bracket using the coordinating mounting holes in the bracket for this drive orientation.

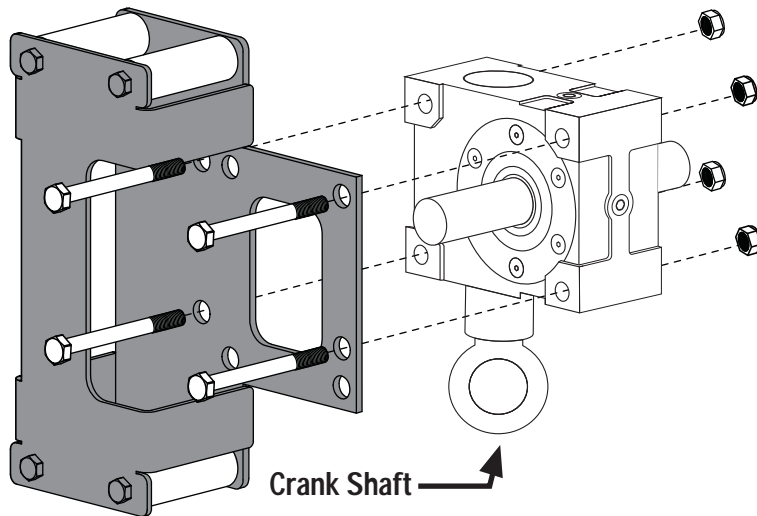

Rear View
of Assembly

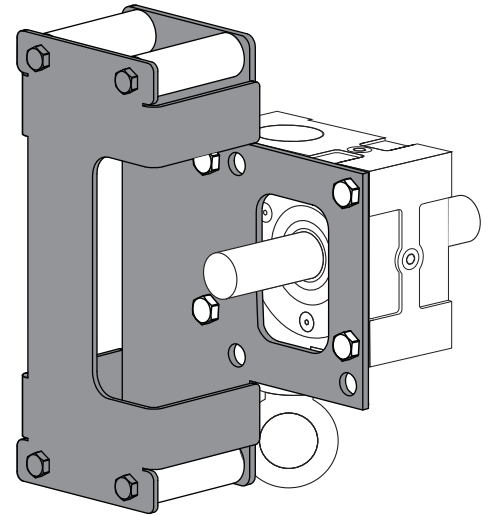

R3

Mark center of climbing bracket. Mark roll tube adapter/s 1" from edge of collar as shown. Slide tube adapter/s onto drive shaft and temporarily secure to shaft by inserting (1) 5/16" x 2-1/2" Hex Bolt through tube adapter collar and shaft hole. Hand tighten (1) 5/16"-18 Nylock Nut to bolt. For end drive systems, install tube adapter to side that is relevant for your system.

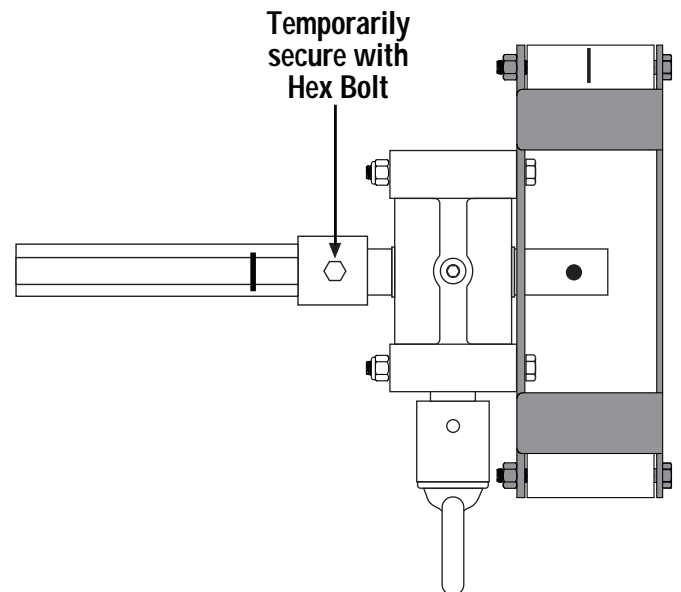
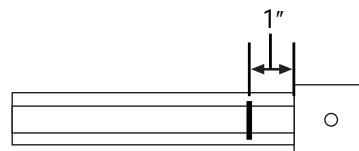
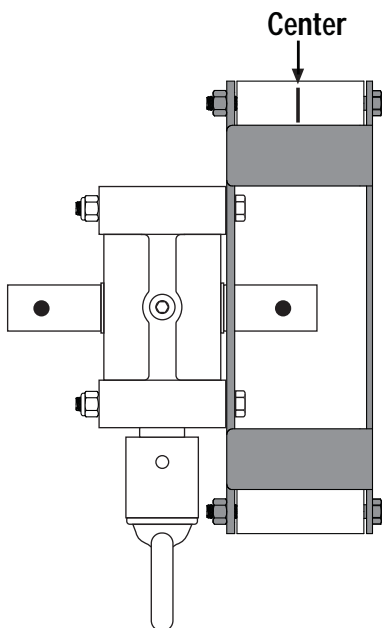

R4

If you are installing only a manual drive system, proceed to [Section T](#).

IMPORTANT: PCSR120W & PCSR250W gear boxes are not weather proof. Until unit/s are sheltered by fully assembled and installed wind pocket it is necessary to keep unit/s protected. Damage or malfunction caused by exposure to weather will not be covered by warranty.

If you are installing a PCSR250W motorized drive system, proceed to Step S3.

Assemble the PCSR120W DC Gearbox onto PSCR840 climbing bracket as shown below. Once assembled, secure DC gear box to bracket using included (4) M8 x 14mm stainless steel Hex Bolts and (4) 5/16" stainless steel Lock Washers.

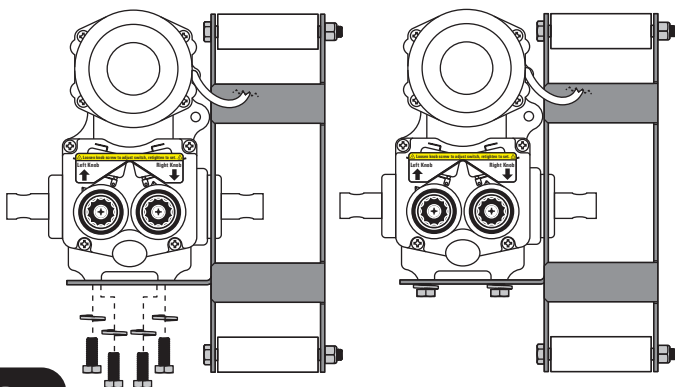
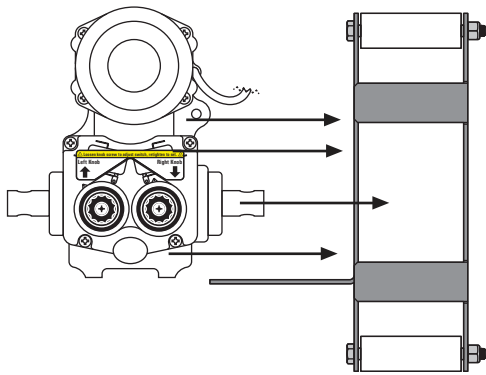
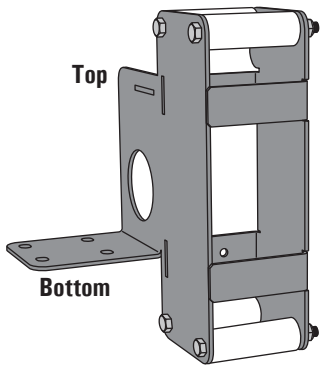

S1

Mark center of climbing bracket. Mark roll tube adapter/s 1" from edge of collar as shown. Slide tube adapter/s onto drive shaft and temporarily secure to shaft by inserting (1) 5/16" x 2-1/2" Hex Bolt through tube adapter collar and shaft hole. Hand tighten (1) 5/16"-18 Nylock Nut to bolt. For end drive systems, install tube adapter to side that is relevant for your system.

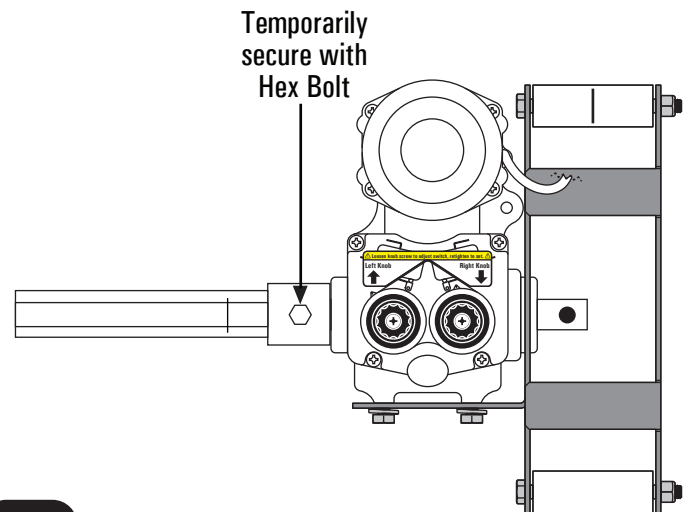
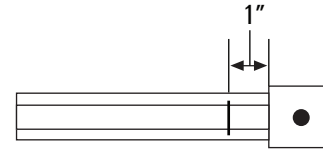
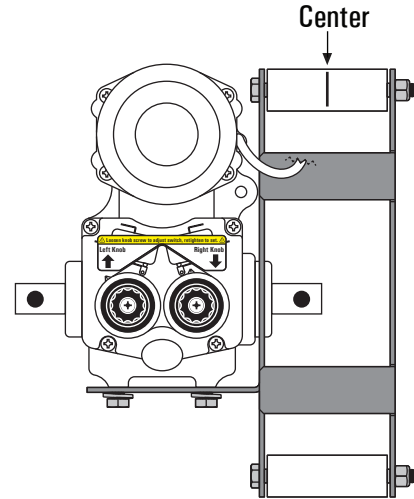

S2

If you are not installing a PCSR250W motorized drive system, proceed to Section T.

Assemble the PCSR250W DC Gearbox onto PCSR845 climbing bracket as shown below. Once assembled, secure DC gear box to bracket using included (4) M10 x 22mm Hex Bolts and (4) M10 Lock Washers.

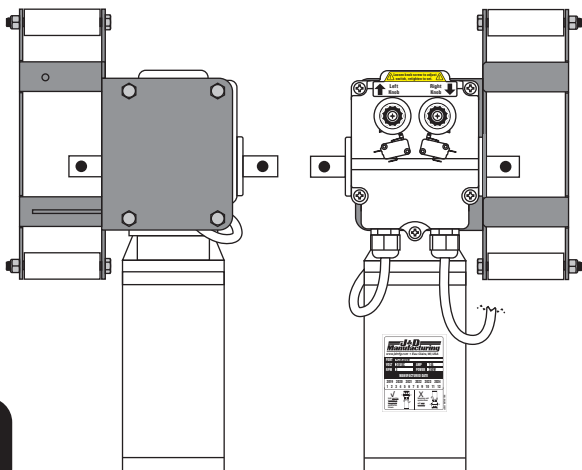
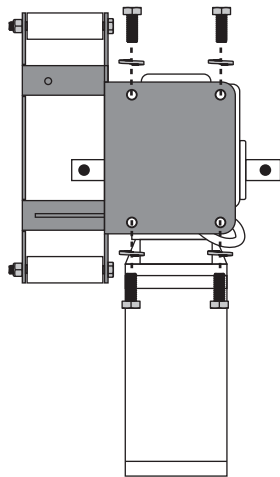
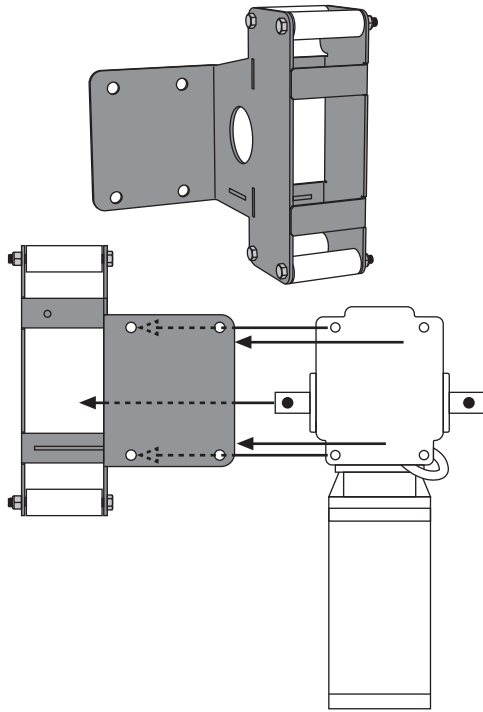

S3

Mark center of climbing bracket. Mark roll tube adapter/s 1" from edge of collar as shown. Slide tube adapter/s onto drive shaft and temporarily secure to shaft by inserting (1) 3/8" x 2-1/2" Hex Bolt through tube adapter collar and shaft hole. Hand tighten (1) 3/8"-16 Nylock Nut to bolt. For end drive systems, install tube adapter to side that is relevant for your system.

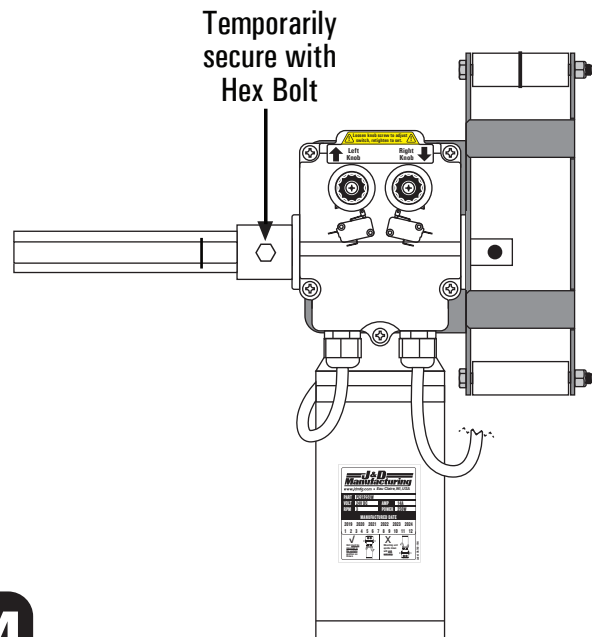
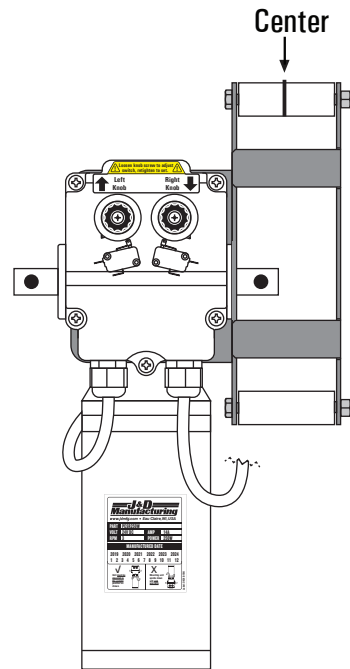

S4

NOTE: From this point forward the term "motorized drive" is used to reference the PCSR120W and PCSR250W interchangeably though the image may only show the PCSR250W the steps and procedures equally apply to the installation of the PCSR120W.

On **ONLY** the roll tubes that will be connected to a drive unit, measure 13" from the end of the roll tube and secure the stretched curtain using (1) #10 x 1" square head Tek screw. Once curtain is secured, remove the screw (1" from the end of the roll tube) that was previously installed to secure the stretched curtain. This will allow the insertion of the roll tube adapter.

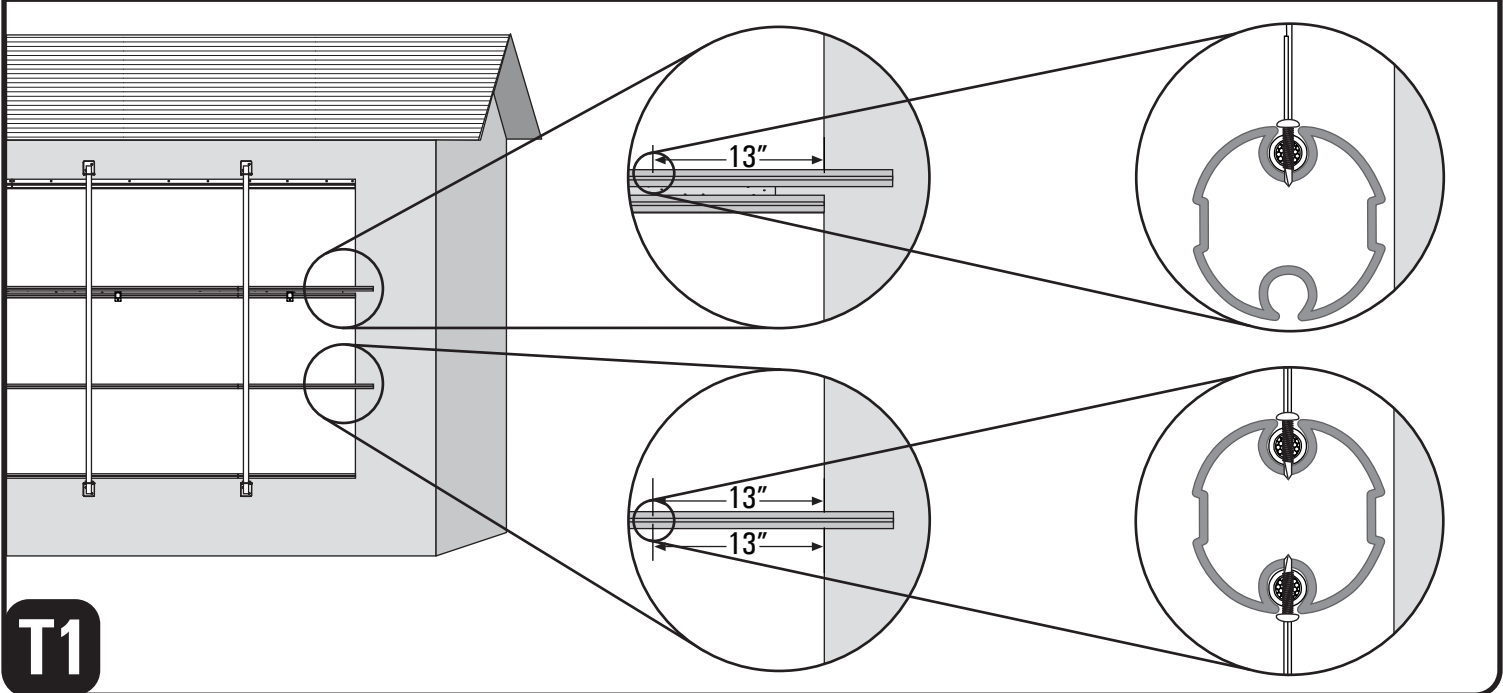

T1

If your system uses a motorized drive or a combination of motorized and manual drives, use motorized drive assembly to mark location of the climbing pole. If your system uses **ONLY** manual drive/s, use manual drive assembly to mark location of the climbing pole.

Insert the roll tube adapter into the roll tube. Allow 1" of the adapter tube to remain un-inserted into the roll tube as shown in *Figure A*. Once the placement of the climbing drive assembly is observed, mark the structure indicating the center of the mounting bracket as shown in *Figure B*.

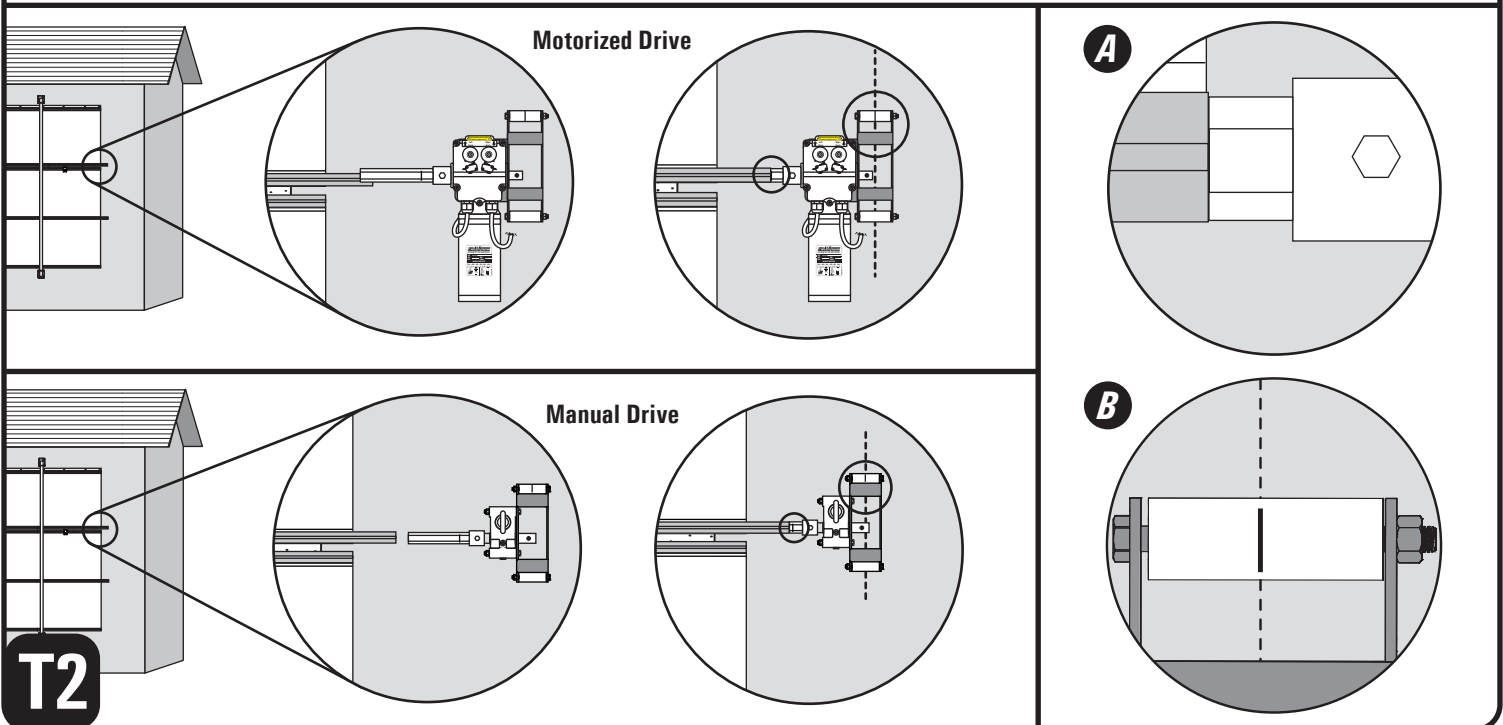

T2

Set aside drive with attached roll tube adapter. Observing mark made in **Step T2**, extend mark above the top of the curtain and below the bottom unrolled curtain using a level.

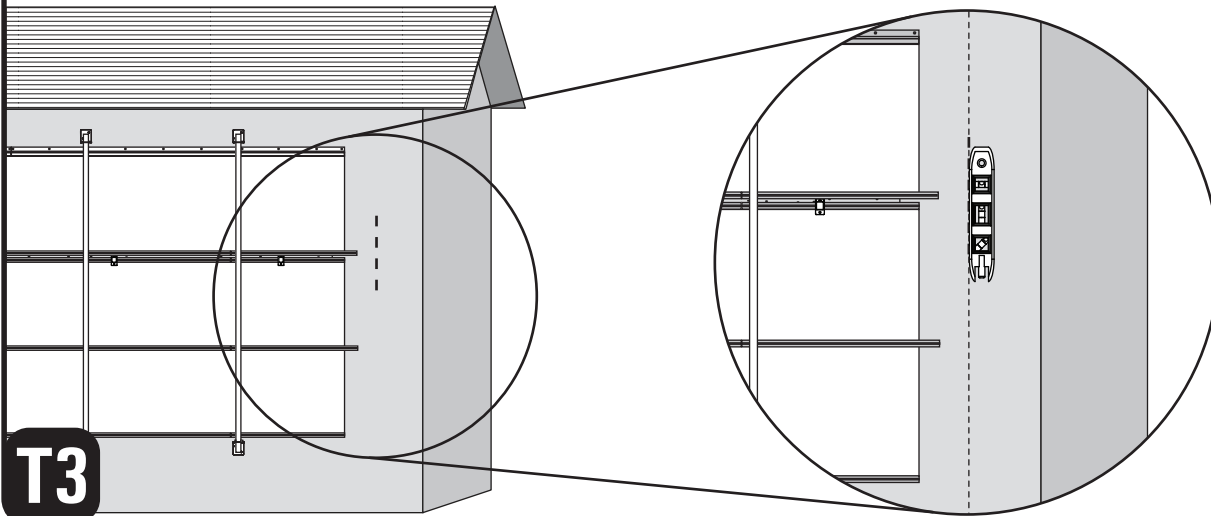

T3

For placement of top climbing pole bracket, measure and mark 6" above the top of curtain. Carry mark over to intersect with vertical mark made in **Step T3**. Place climbing pole bracket at intersection of markings with top of bracket aligning with the horizontal mark, and center of bracket over the vertical mark as shown below. Secure bracket using (4) fasteners specific to your building type, refer to **Section B - Page# 1** for hardware installation specifications.

For placement of bottom climbing pole bracket, measure and mark 4" below the bottom of curtain. Carry mark over to intersect with vertical mark made in **Step T3**. Place climbing pole bracket at intersection of markings with top of bracket aligning with the horizontal mark, and center of bracket over the vertical mark as shown below. Secure bracket using (4) fasteners specific to your building type, refer to **Section B - Page# 1** for hardware installation specifications.

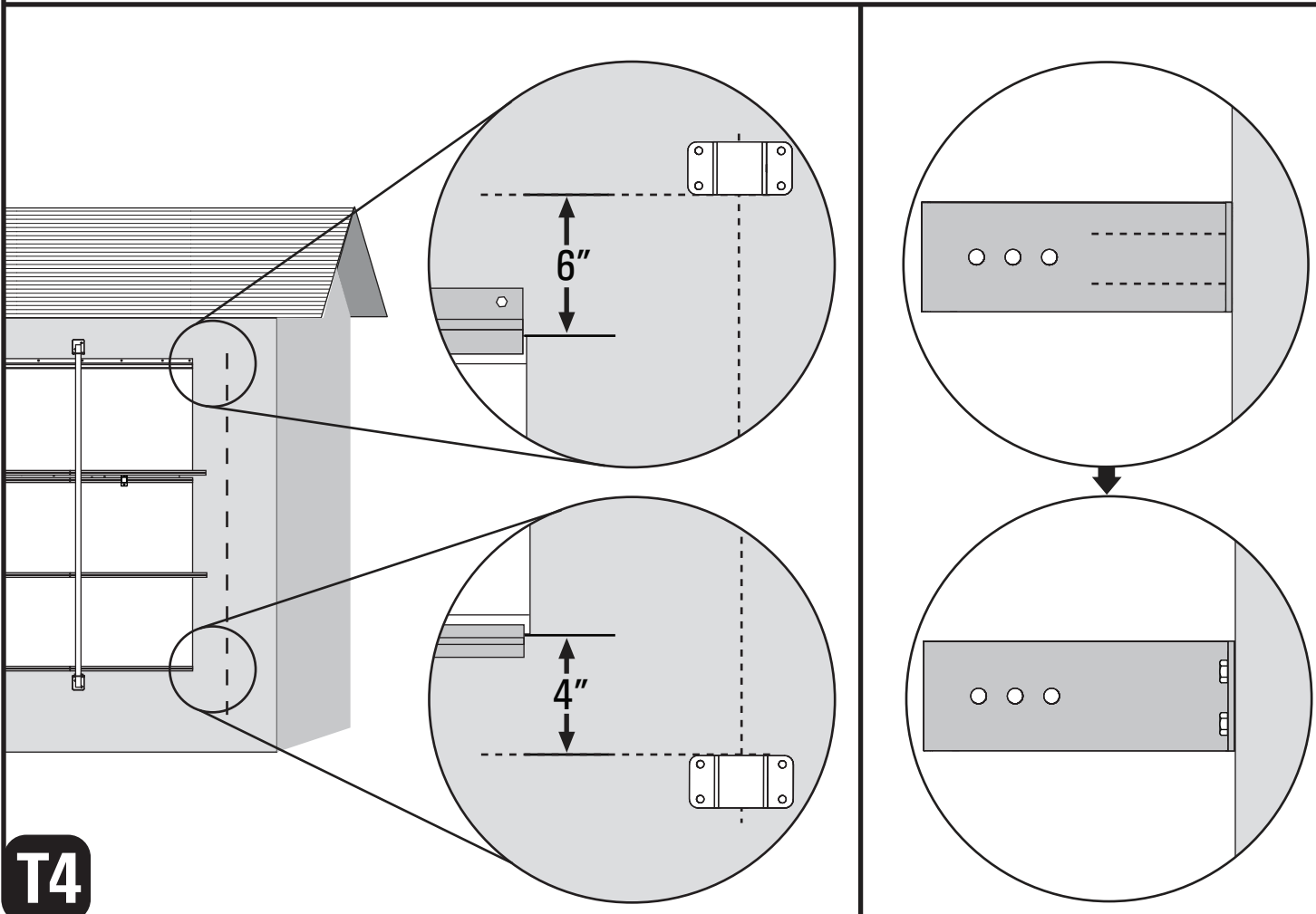

T4

Insert climbing pole into climbing pole brackets to desired height. Mark locations for required hole drilling. Remove climbing pole. Using 1/2" drill bit, drill holes through top and bottom of climbing pole. DO NOT attach pole to brackets at this time.

Multiple pole settings on the climbing pole brackets enable adjustments for system movement and/or structure irregularities.

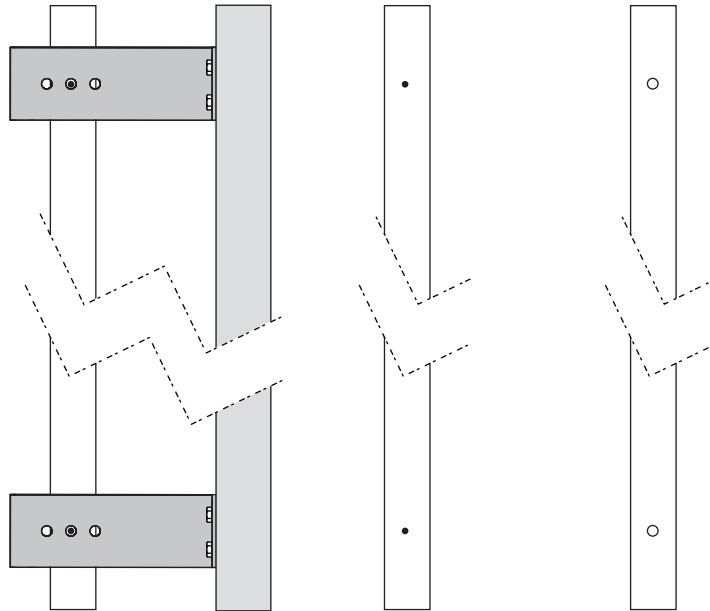

T5

Remove roll tube adapter/s that you temporarily attached to the drive/s in **Section R** or **Section S**. Insert climbing pole through climbing bracket drive assembly/s. Install climbing pole with drives by inserting pole ends into climbing pole brackets and securing pole with (1) 3/8"-16 x 4" Hex Bolt and (1) 3/8"-16 Nylock Nut per climbing pole bracket.

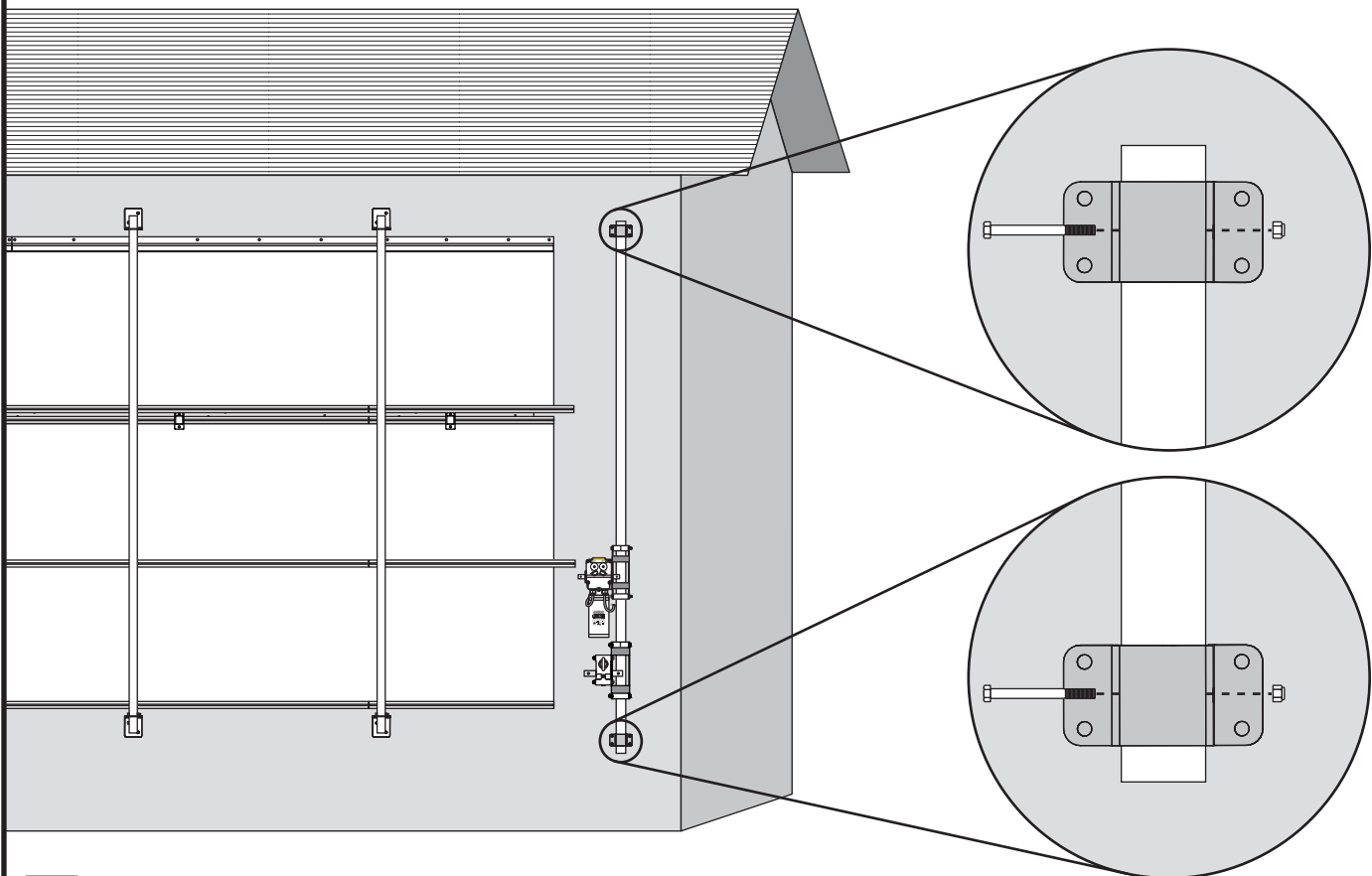

T6

Insert roll tube adapter into roll tube. Slide drive assembly unit up the climbing pole to meet roll tube adapter. Insert drive shaft into adapter collar and secure to drive shaft with (1) 5/16" x 2-1/2" Hex Bolt and (1) 5/16"-18 Nylock Nut. Tighten hardware to secure. Fasten roll tube to roll tube adapter as you did with the roll tube splice in **Step L3**. Repeat this step for each drive assembly unit on climbing pole.

NOTE: In systems with both powered and manual drives the amount of protruding roll tube will vary due to the varying width of each drive this is normal.

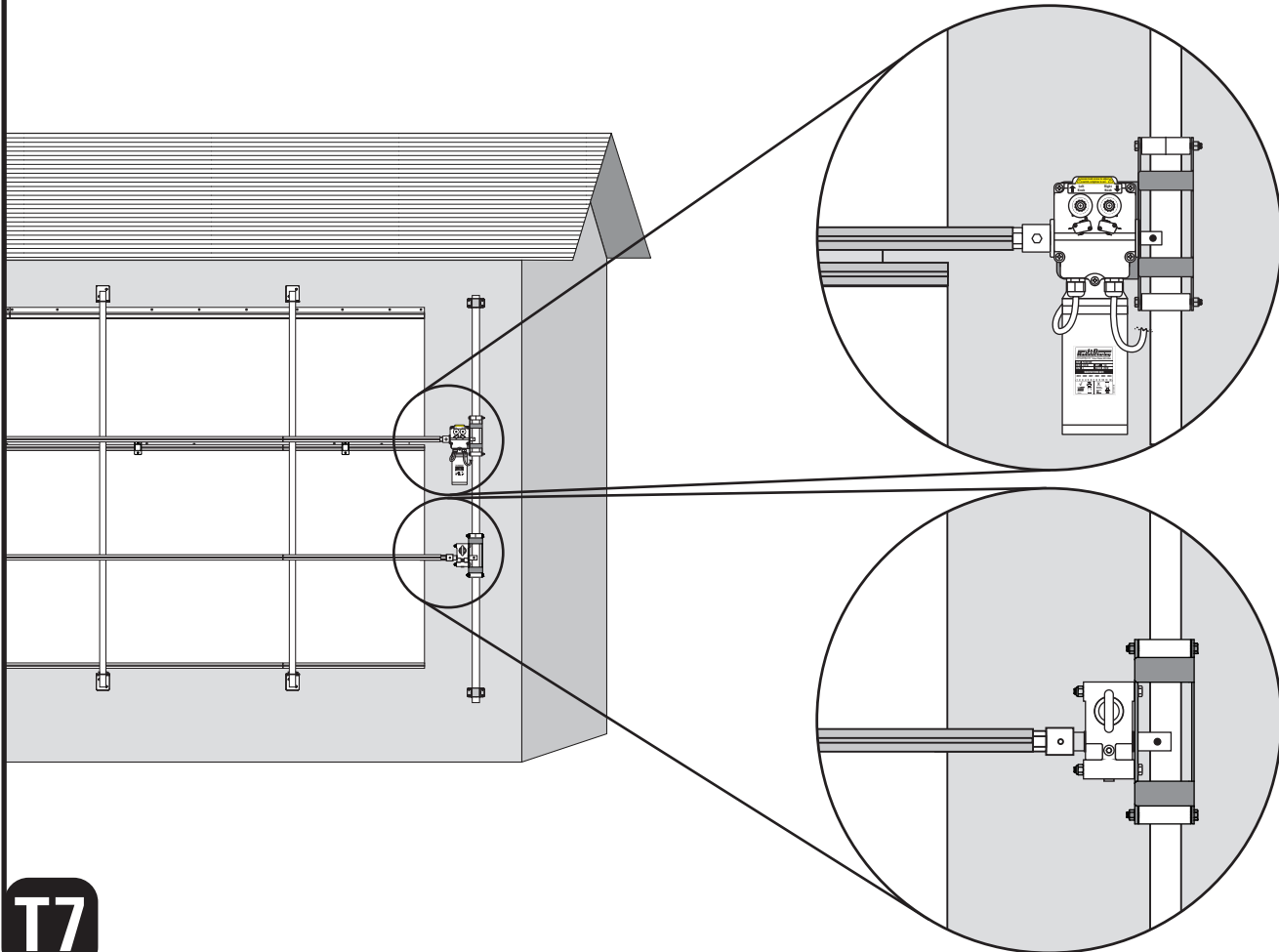

T7

If your system **ONLY** uses manual drive/s, proceed to **Section V**.

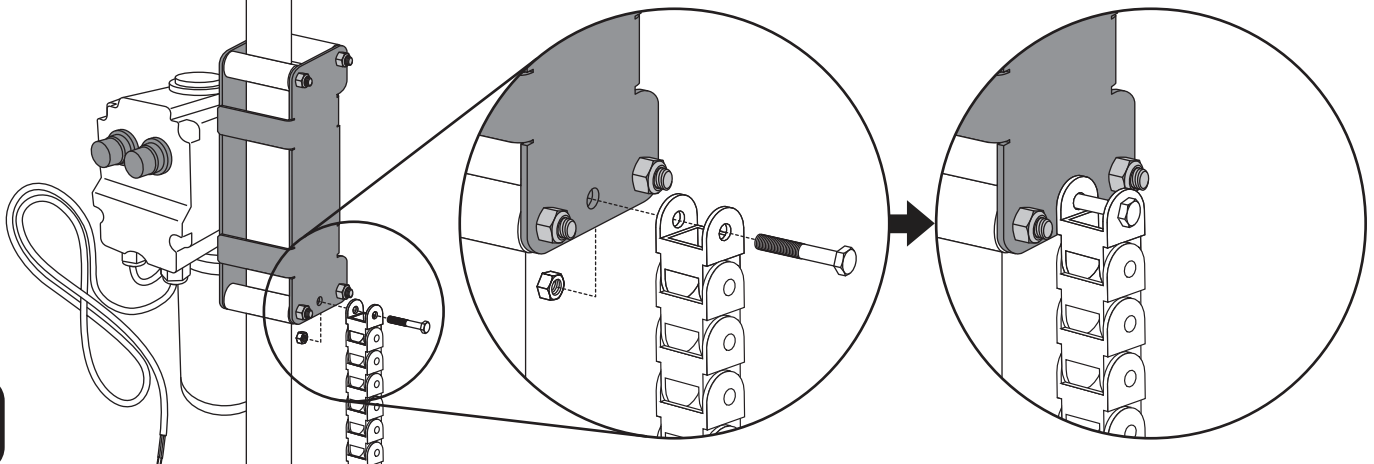
Attach cable carrier to motorized climbing drive bracket using (1) M6-1.0 x 40mm Hex Bolt and (1) M6-1.0 Nylock Nut as shown below.

T8

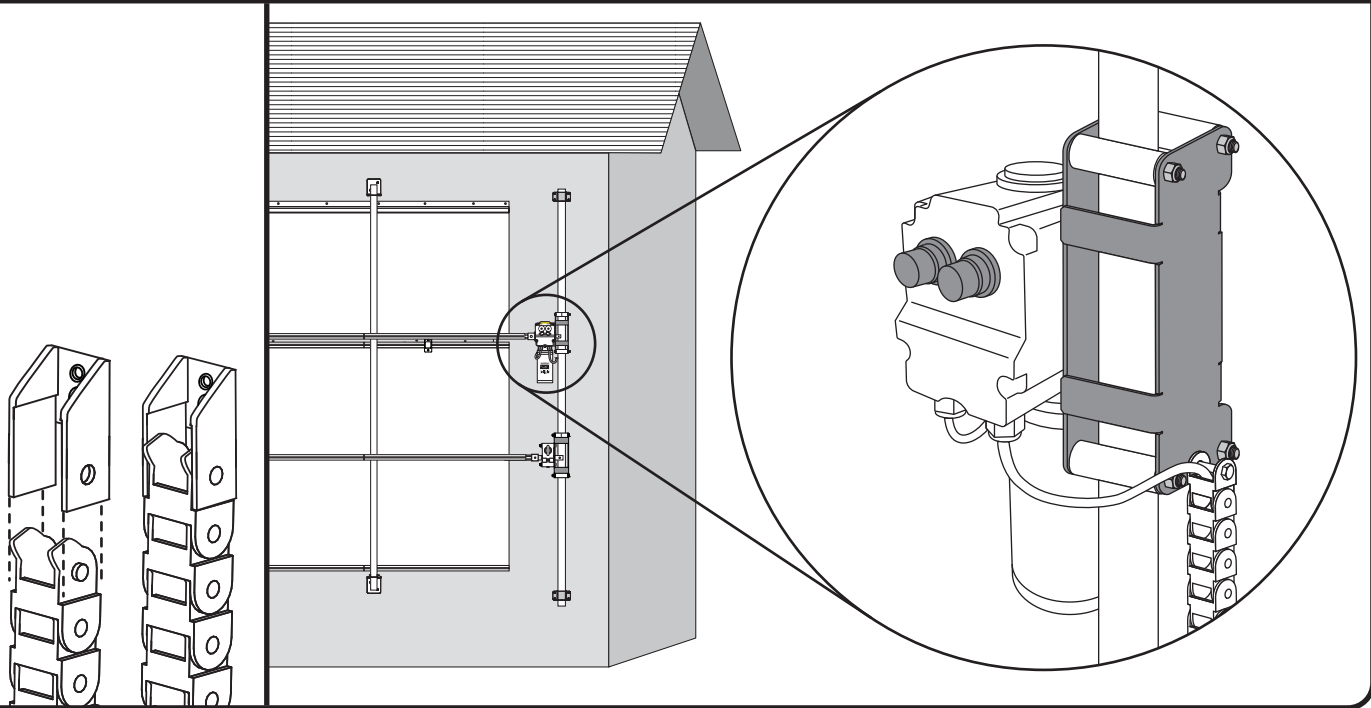
Attach cable carrier mounting bracket to end of cable carrier by sliding end of cable carrier end into bottom of mounting bracket until nubs click securely into hinge holes. Feed power cable through cable carrier.

T9

With drive in the lowest possible position, guide the cable carrier mounting bracket behind and above climbing bracket. Secure to the structure using (2) fasteners specific to your building type, either (2) Wood Screws #5-20 x 1-1/2" or (2) Self Tapping Screw #4-24 x 1/2".

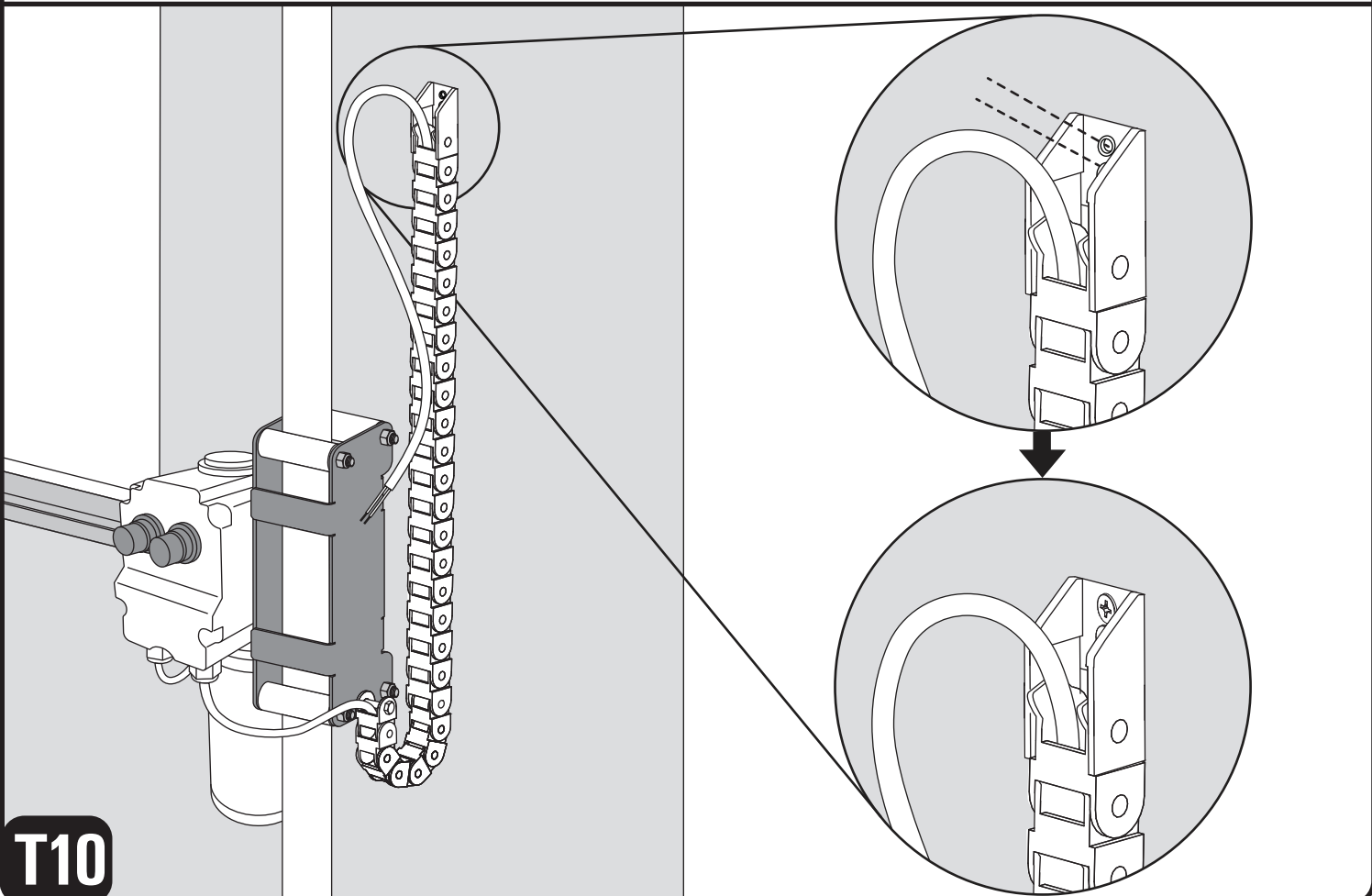
T10

PCSR317 Manual Gear Box

WARNING!

Failure to adhere to the following instructions will void warranty and damage unit.

- *Once unit is mounted in its operating position, remove and discard gearbox plug from the top side of gearbox and replace with the Hex Head Breather Bolt to allow for contraction and expansion of lubricant.*
- If unit is operated by the use of a drill ONLY use standard drill on low speed
 - **Do NOT** use Hammerdrill or Impact Driver
 - **Do NOT** exceed 150 RPMs

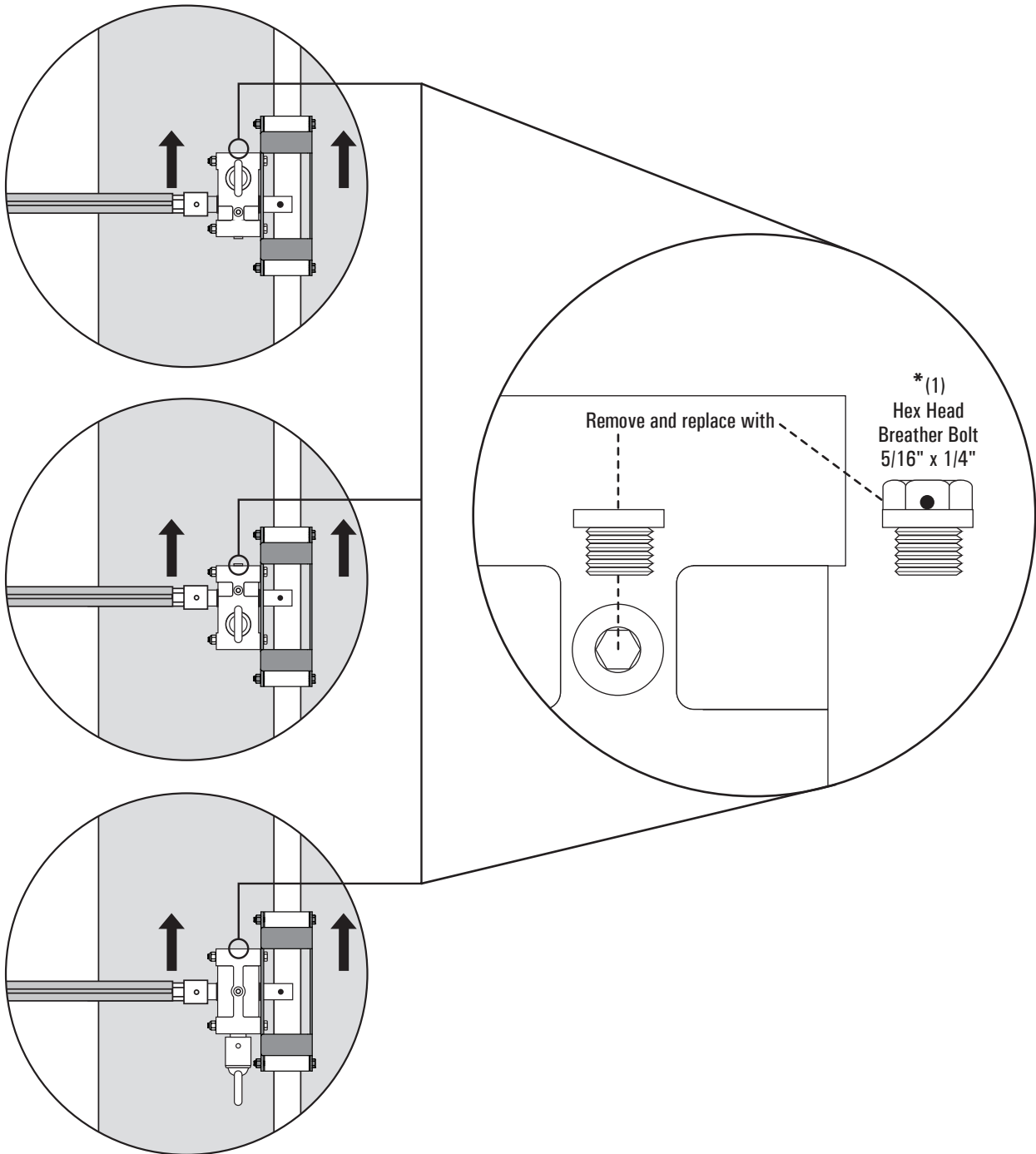
**T11**

PCSR120W & PCSR250W Motorized Gear Box

WARNING!

Failure to adhere to the following instructions will void warranty.

- PCSR120W and PCSR250W are not weather proof. Until unit/s is sheltered by fully assembled and installed wind pocket **it is necessary to keep unit/s protected.** Damage or malfunction caused by exposure to weather will not be covered by warranty.
- Unit **must be mounted in the upright position** as shown. **Mounting unit upside down will void warranty.**
- **Do not provide power to the unit until setting limits.** **Running unit prior to setting limits can cause irreparable damage to curtain and gear box, voiding all warranties.**

Refer to instructions included with unit for further information regarding wiring guidelines and setting limit switches.

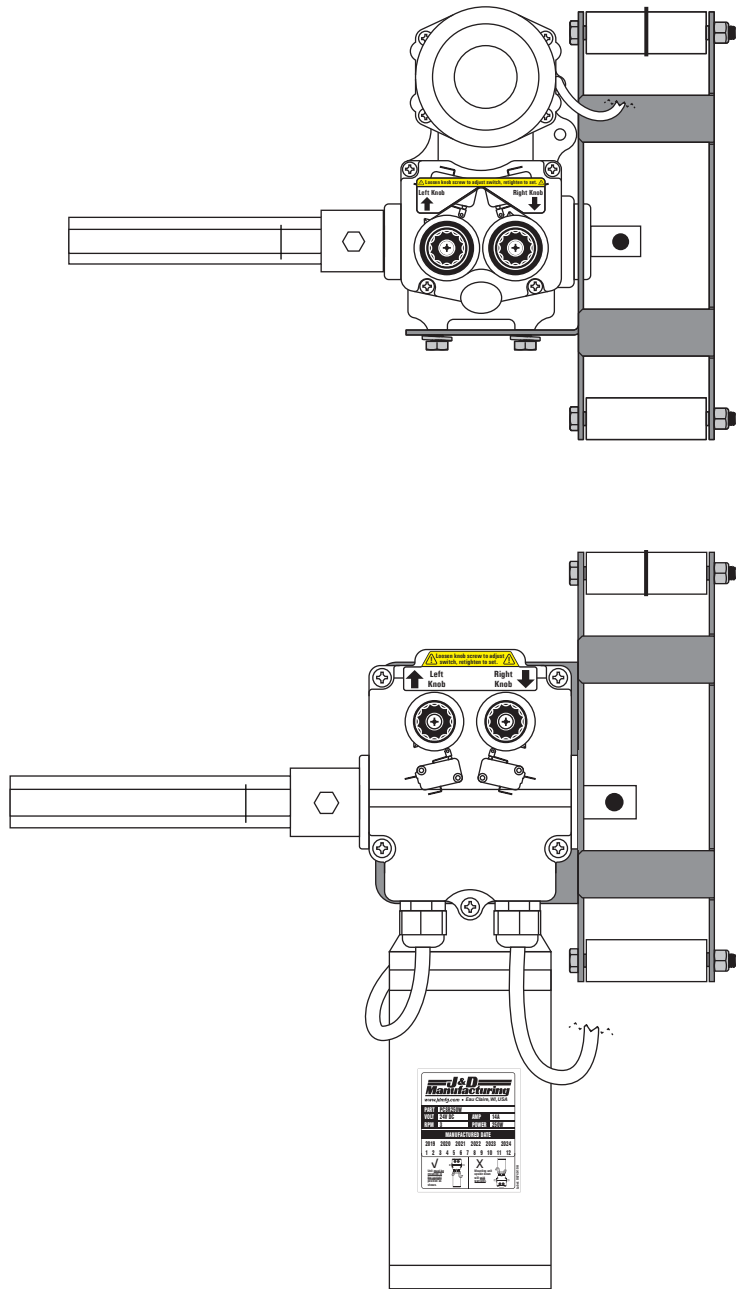

T12

Assemble drive wind pocket frame by attaching the side pieces to the mounting brackets using (4) ¼"-14 x 1¼" Hex Head Tek Screws per mounting bracket as shown below.

Center Drive Wind Pocket

End Drive Wind Pocket

(open/closed side pieces are interchangeable)

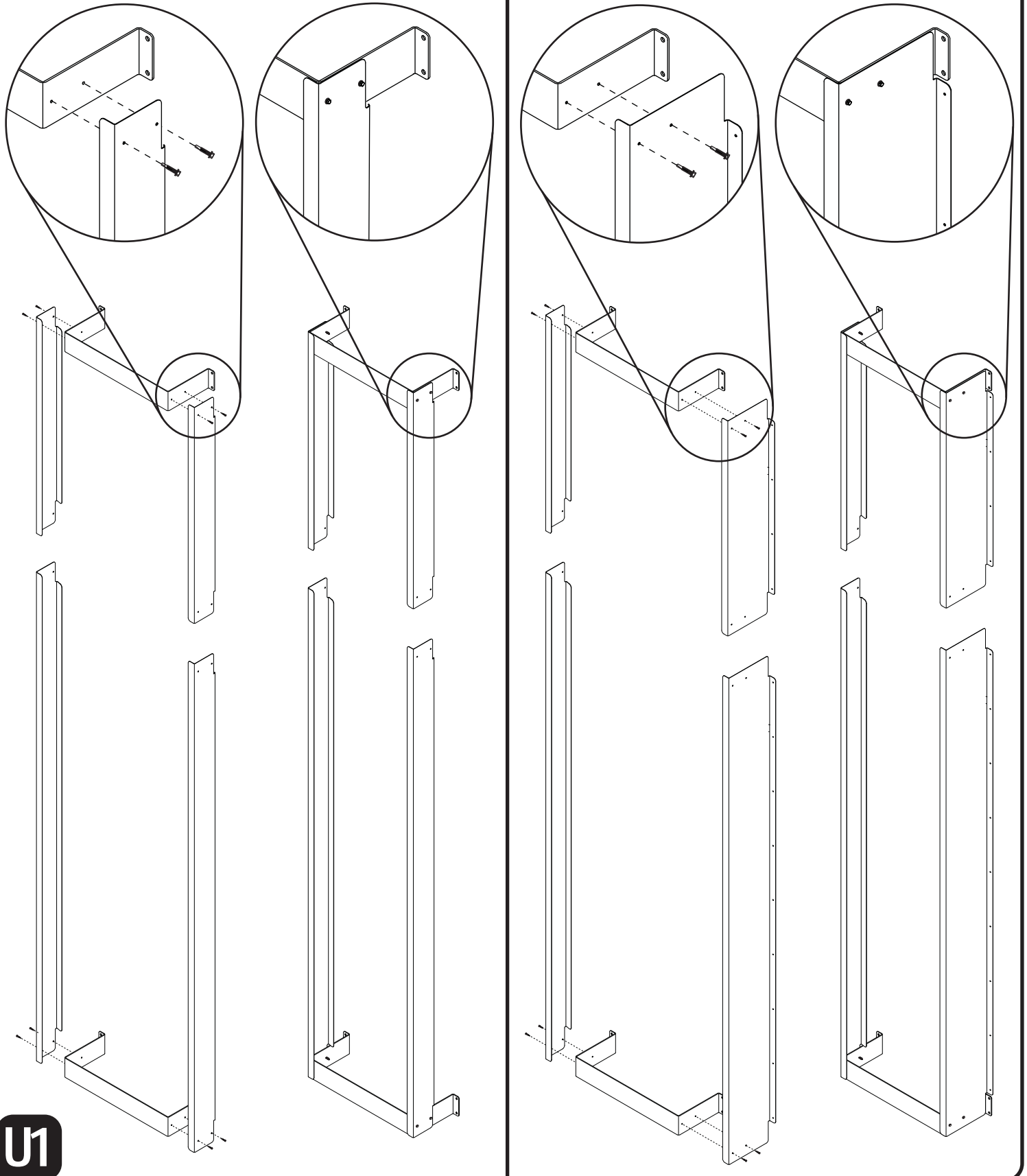

Align bottom of side splice support with top edge of mounting bracket. Using (4) 1/4"-14 x 1 1/4" Hex Head Tek Screws per side splice as shown below, secure side splice to wind pocket side.

Center Drive Wind Pocket

End Drive Wind Pocket
(open/closed side pieces are interchangeable)

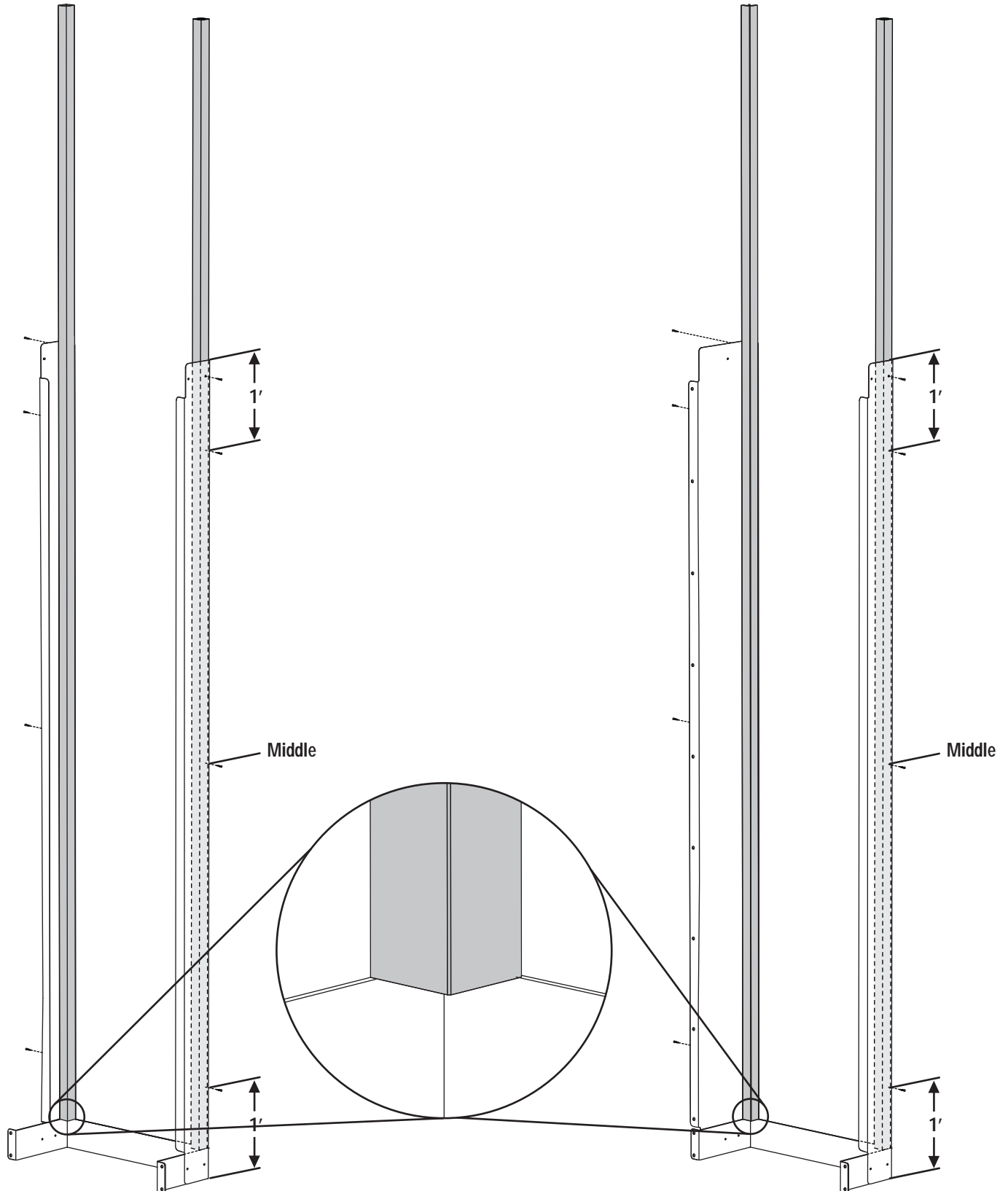

Align top of side splice support with bottom edge of mounting bracket. Using (3) 1/4"-14 x 1 1/4" Hex Head Tek Screws per side splice as shown below, secure side splice to wind pocket side. There will be a 1/4" gap between the top and bottom wind pocket sides.

Center Drive Wind Pocket

End Drive Wind Pocket
(open/closed side pieces are interchangeable)

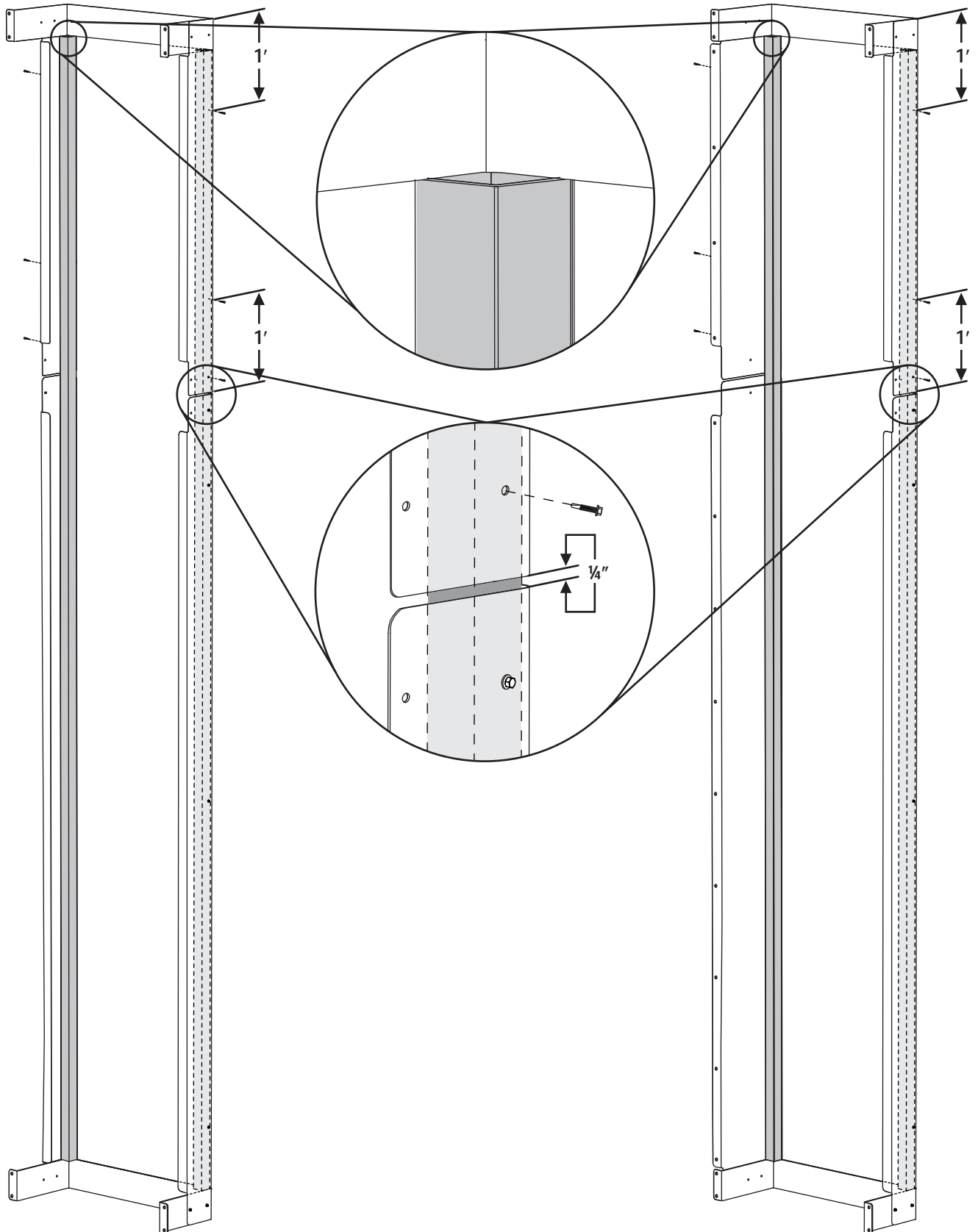

U3

Assemble the top and bottom of the dead end wind pockets that needs splicing along with dead end splice. Using (4) 1/4"-14 x 1 1/4" Hex Head Tek Screws secure dead end splice to dead end wind pocket as shown below.

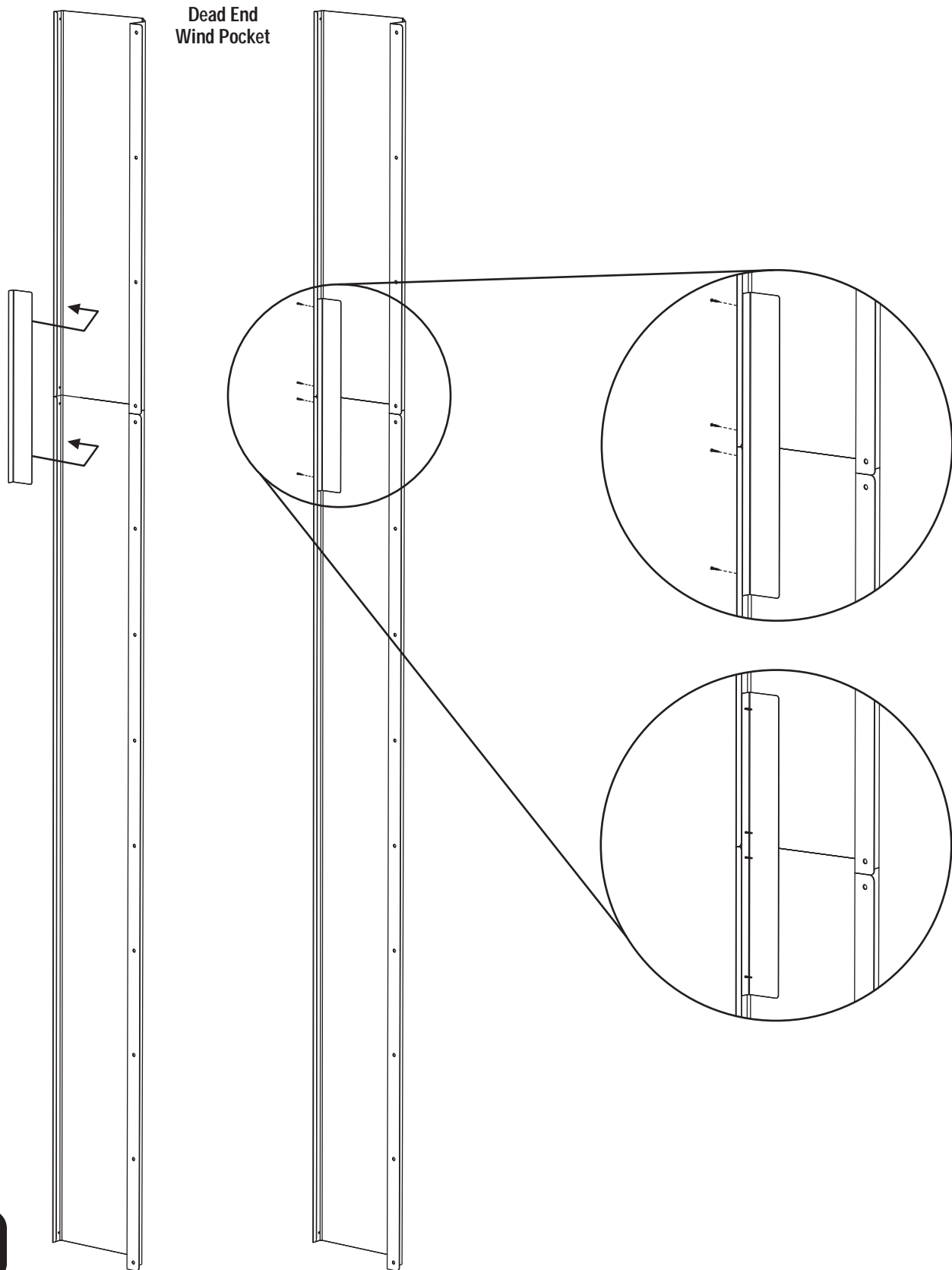

U4

Proceed to standard Dead End and Drive wind pocket instructions for further installation and assembly directions.

Attach the mounting brackets to the top and bottom of the dead end curtain wind pocket using (1) 1/4"-14 x 1-1/4" Hex Head Tek Screw per bracket. The dead end curtain wind pocket is universal, allowing it to be used on either side of curtain by rotating the finished assembly 180°.

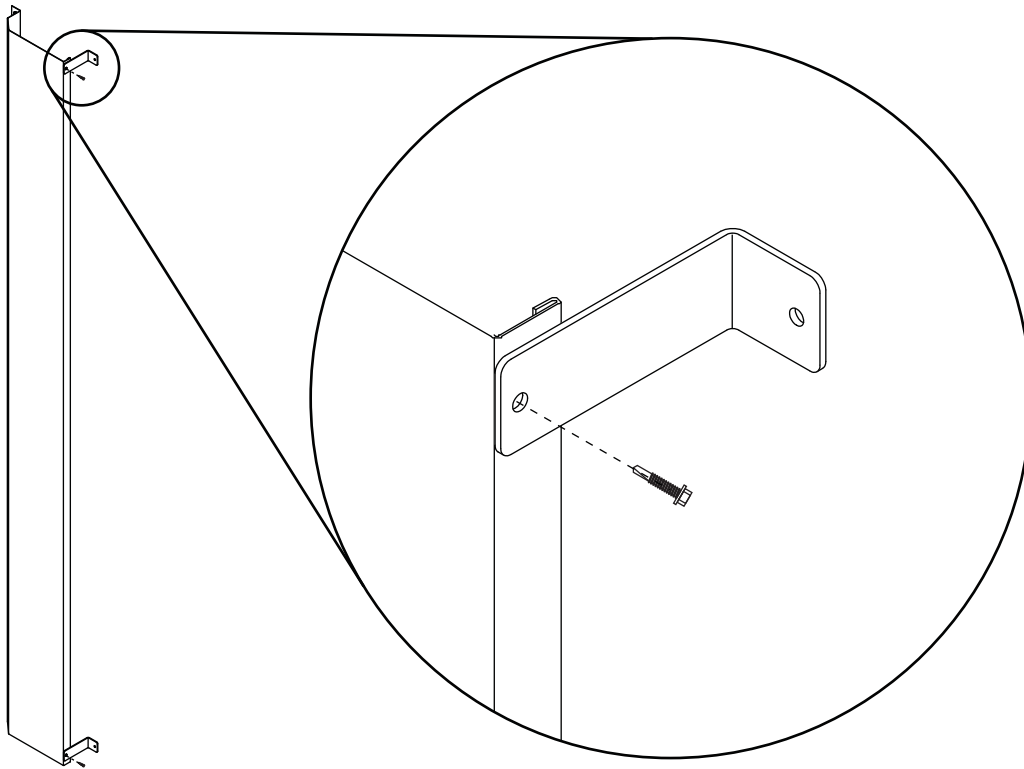
**V1**

Install the dead end curtain wind pocket assembly over the dead end of the curtain. Secure dead end wind pocket using fasteners specific to your building type (refer to [Section B - Page #1](#) for hardware installation specifications). Quantity of fasteners required will depend on the size of the dead end wind pocket you are installing.

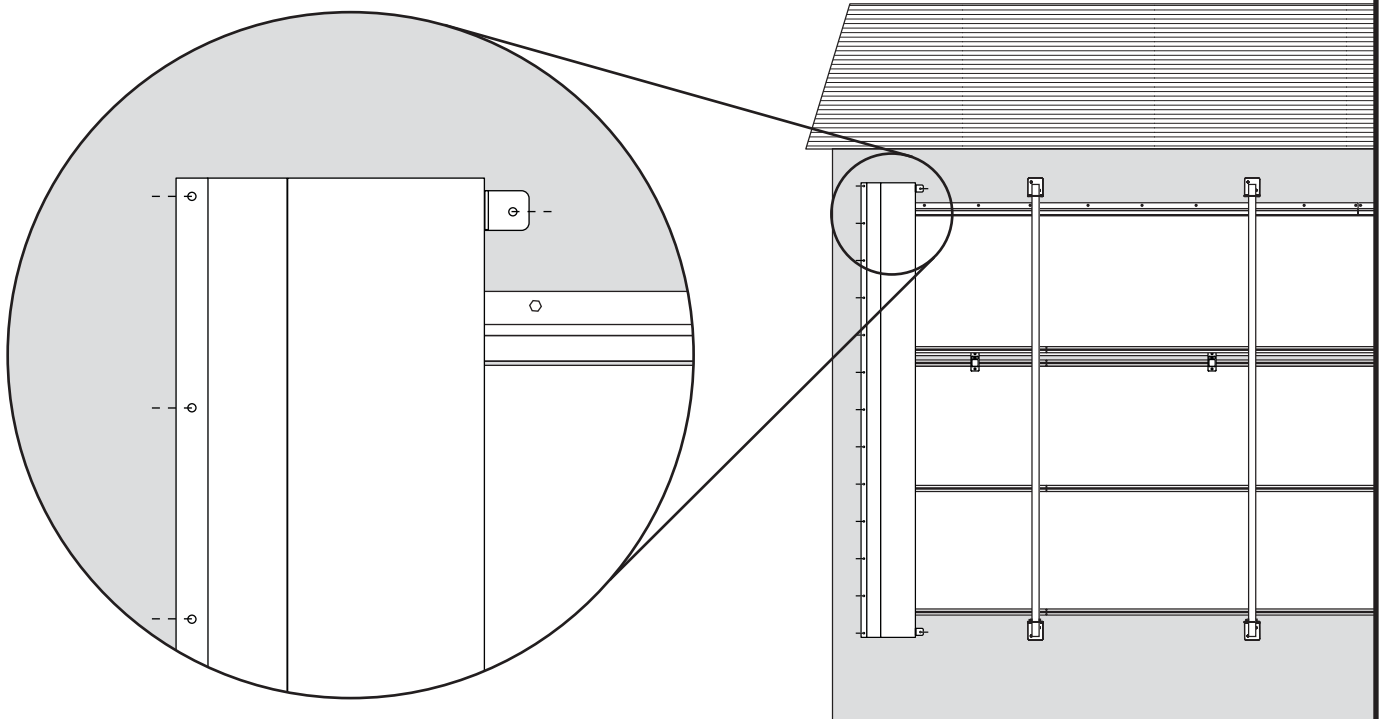
**V2**

If you are installing a Center Drive Wind Pocket, proceed to [Section W](#).

Assemble center drive wind pocket frame by attaching an open side piece on both sides of the mounting brackets using (4) 1/4"-14 x 1-1/4" Hex Head Tek Screws per side piece as shown below.

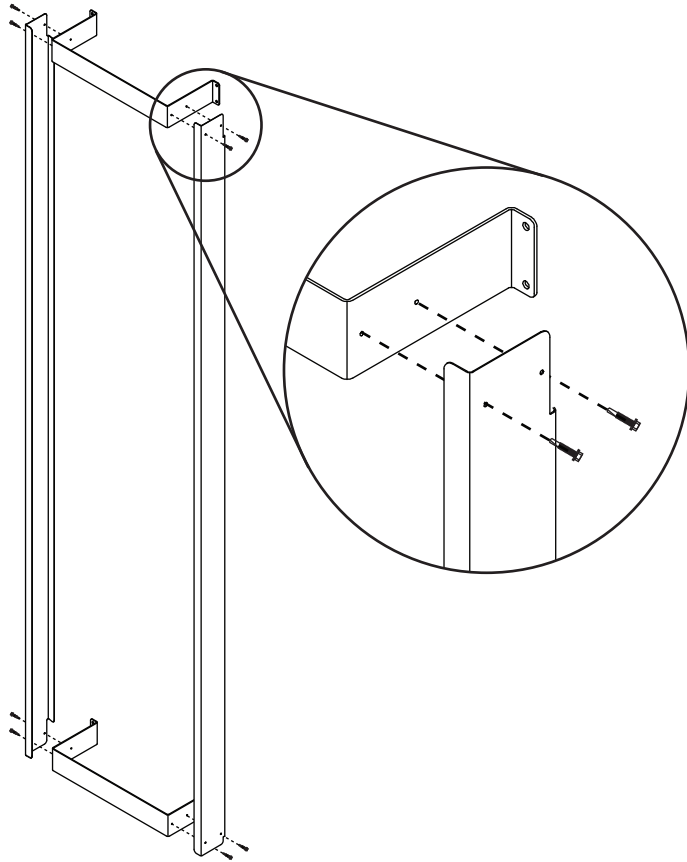

W1

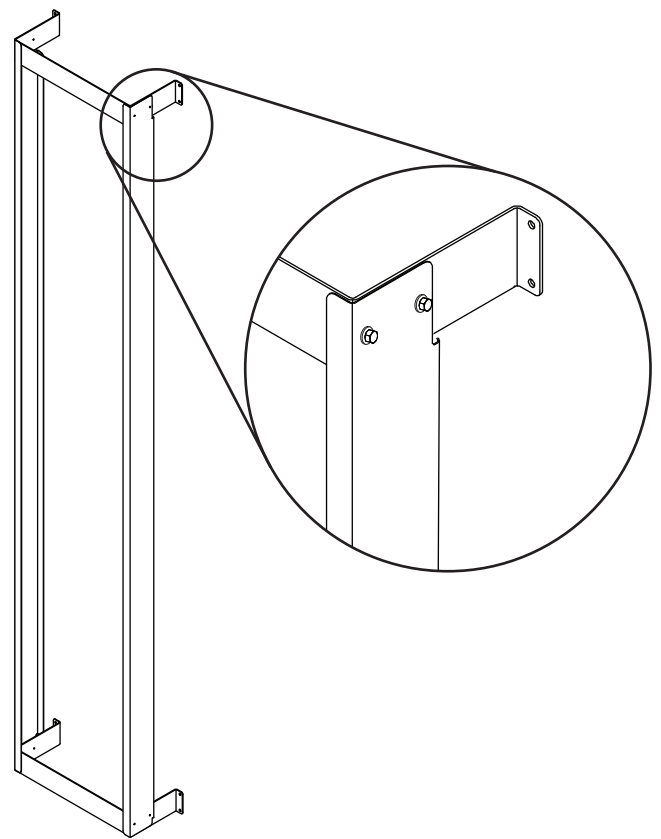

Place center drive wind pocket frame over drives as shown below. Visually confirm that frame will not interfere with drive or curtain movement when operating unit. Once location is confirmed secure center drive wind pocket frame using (8) fasteners specific to your building type (refer to **Section B - Page #1** for hardware installation specifications).

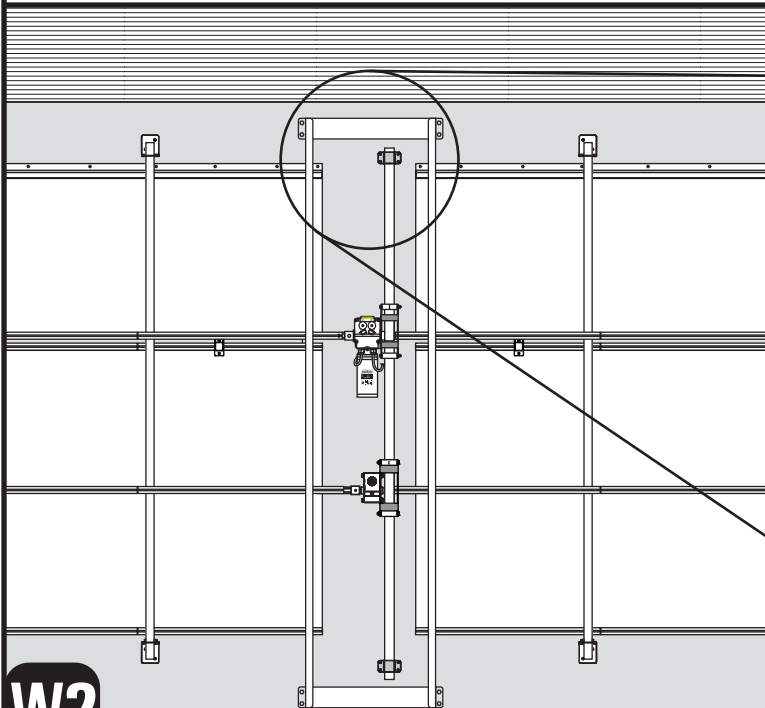

W2

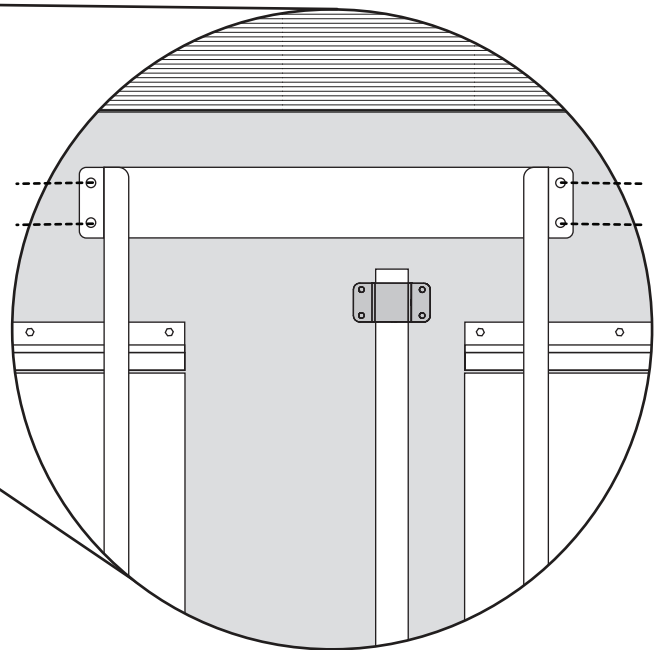

Prepare door by inserting (1) door support in the top and (1) in the bottom of the door as shown in *Figure A*. Secure supports using (5) #10 x 1" Square Head Tek Screws per door end as shown in *Figure B*. Install (2) door hinge brackets using (2) 1/4"-14 x 1-1/4" Hex Head Tek Screws per bracket and pre-lasere holes in door edge as shown in *Figure C*.

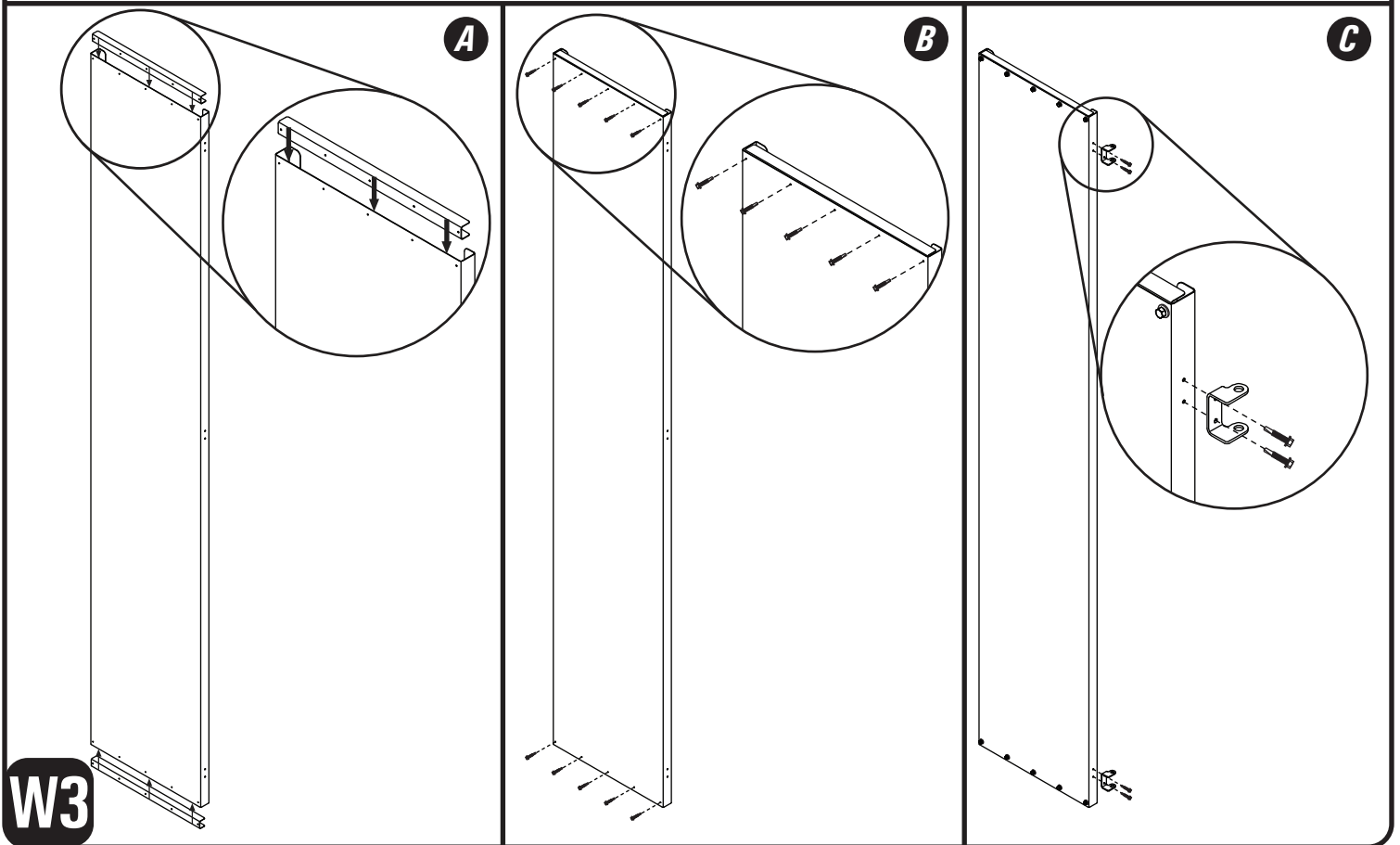

Place door against frame. Using hinge brackets installed in previous step as your guide, attach (2) other hinge brackets and hinge pins to the bracket to verify placement of second hinges on door frame. Secure hinge brackets to frame using (2) 1/4"-14 x 1-1/4" Hex Head Tek Screws per bracket as shown.

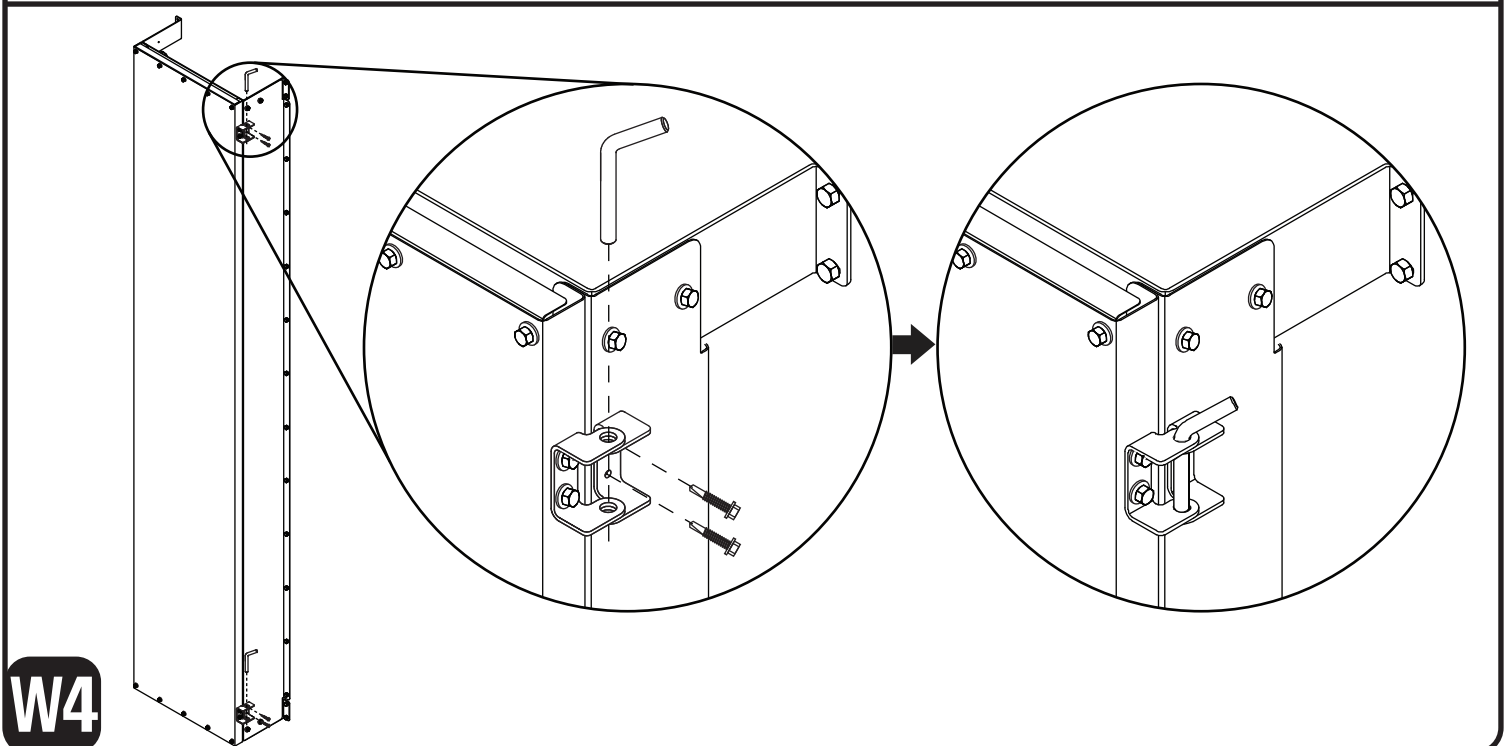

With door closed, secure hinge/latch bracket to frame and door at preferred height using (2) 1/4"-14 x 1-1/4" Hex Head Tek Screws per bracket as shown.

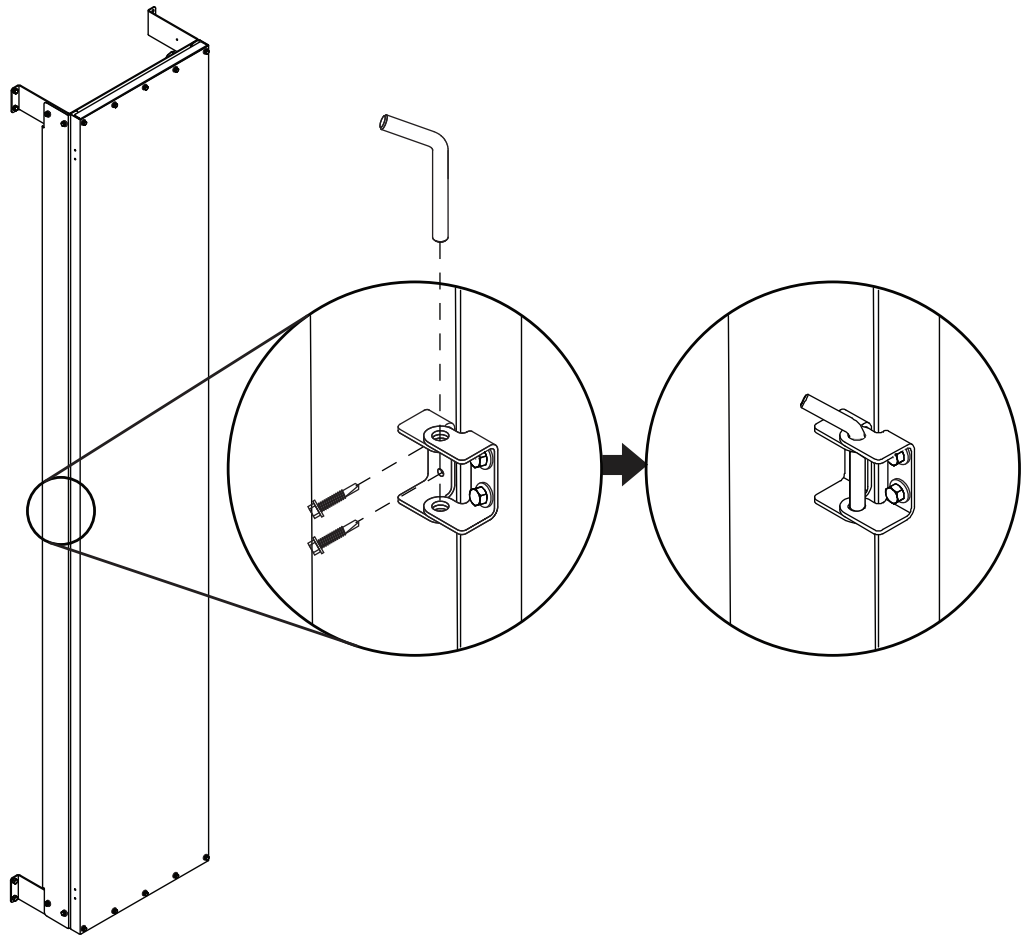
**W5**

If not installing optional wind pocket cover proceed to [Section Z](#) for maintenance and operating instructions.

Assemble end drive wind pocket frame by attaching the closed side piece on one side and the open side piece on the other side of the mounting brackets using (4) 1/4"-14 x 1-1/4" Hex Head Tek Screws per side piece as shown below. The end drive wind pocket is universal, allowing it to be used on either side of curtain by rotating the assembled frame 180°.

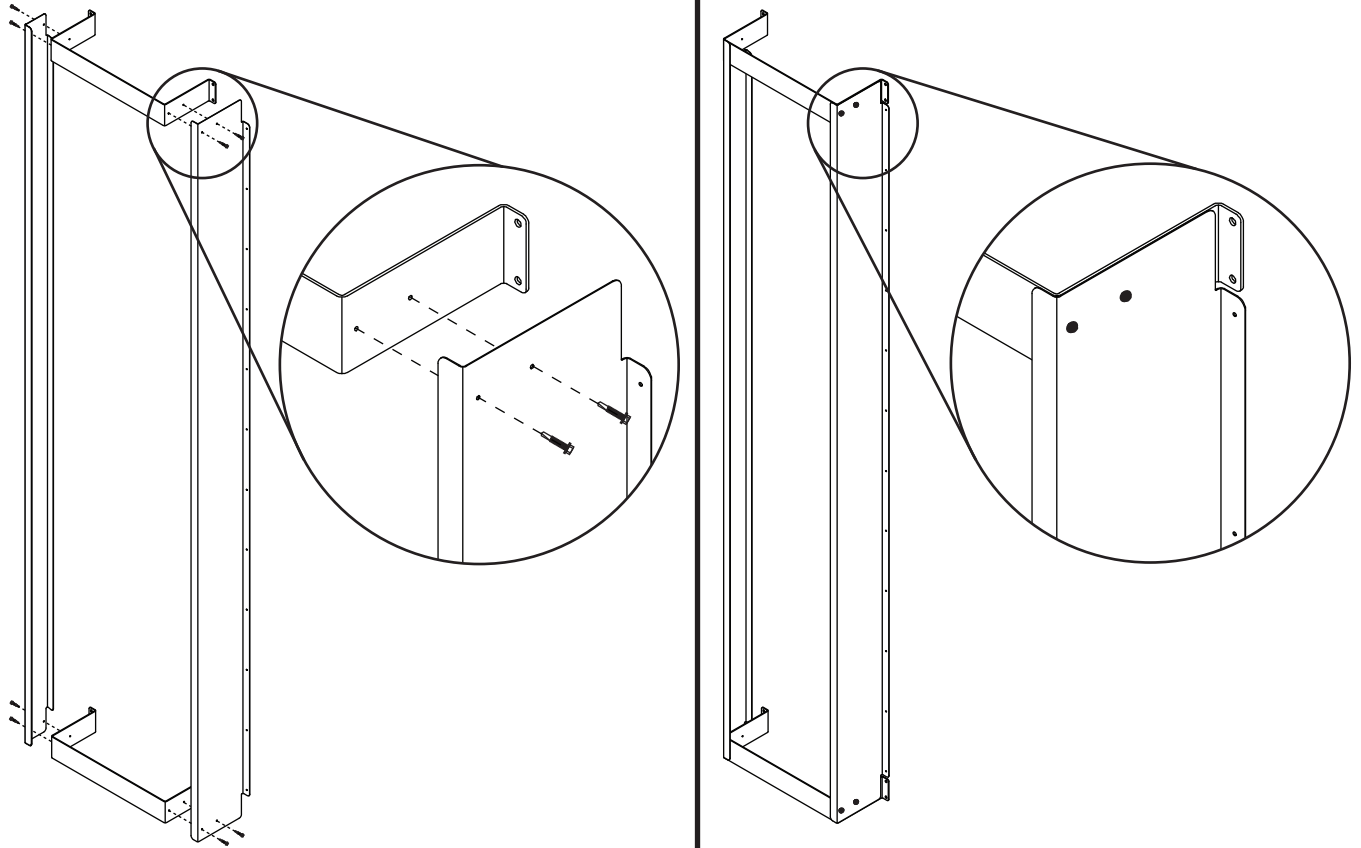

X1

Place end drive wind pocket frame over drives as shown below. Visually confirm that frame will not interfere with drive or curtain movement when operating unit. Once location is confirmed, Secure end drive wind pocket frame using fasteners specific to your building type (refer to **Section B - Page #1** for hardware installation specifications). Quantity of fasteners required will depend on the size of the end drive wind pocket frame you are installing.

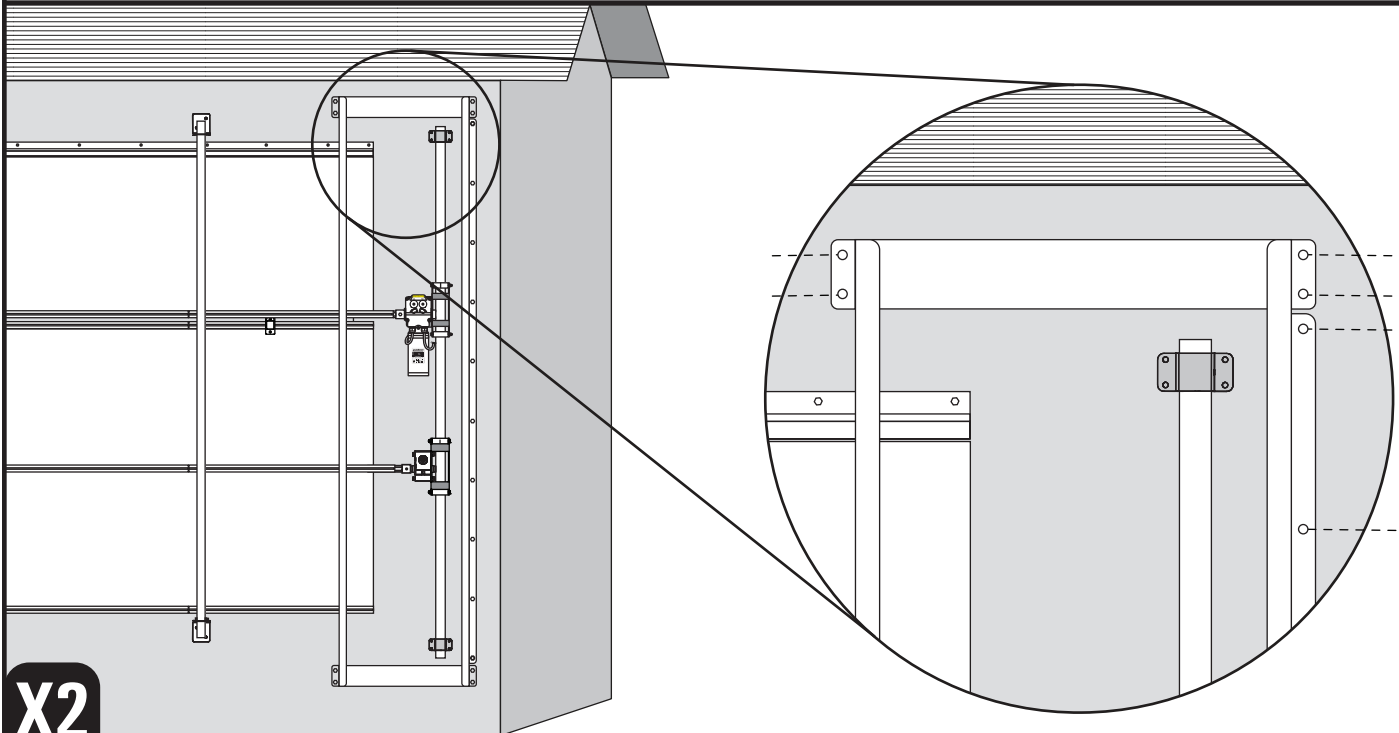

X2

Prepare door by inserting (1) door support in the top and (1) in the bottom of the door as shown in *Figure A*. Secure supports using (5) #10 x 1" Square Head Tek Screws per door end as shown in *Figure B*. Install (2) door hinge brackets using (2) 1/4"-14 x 1-1/4" Hex Head Tek Screws per bracket and pre-lasere holes in door edge as shown in *Figure C*.

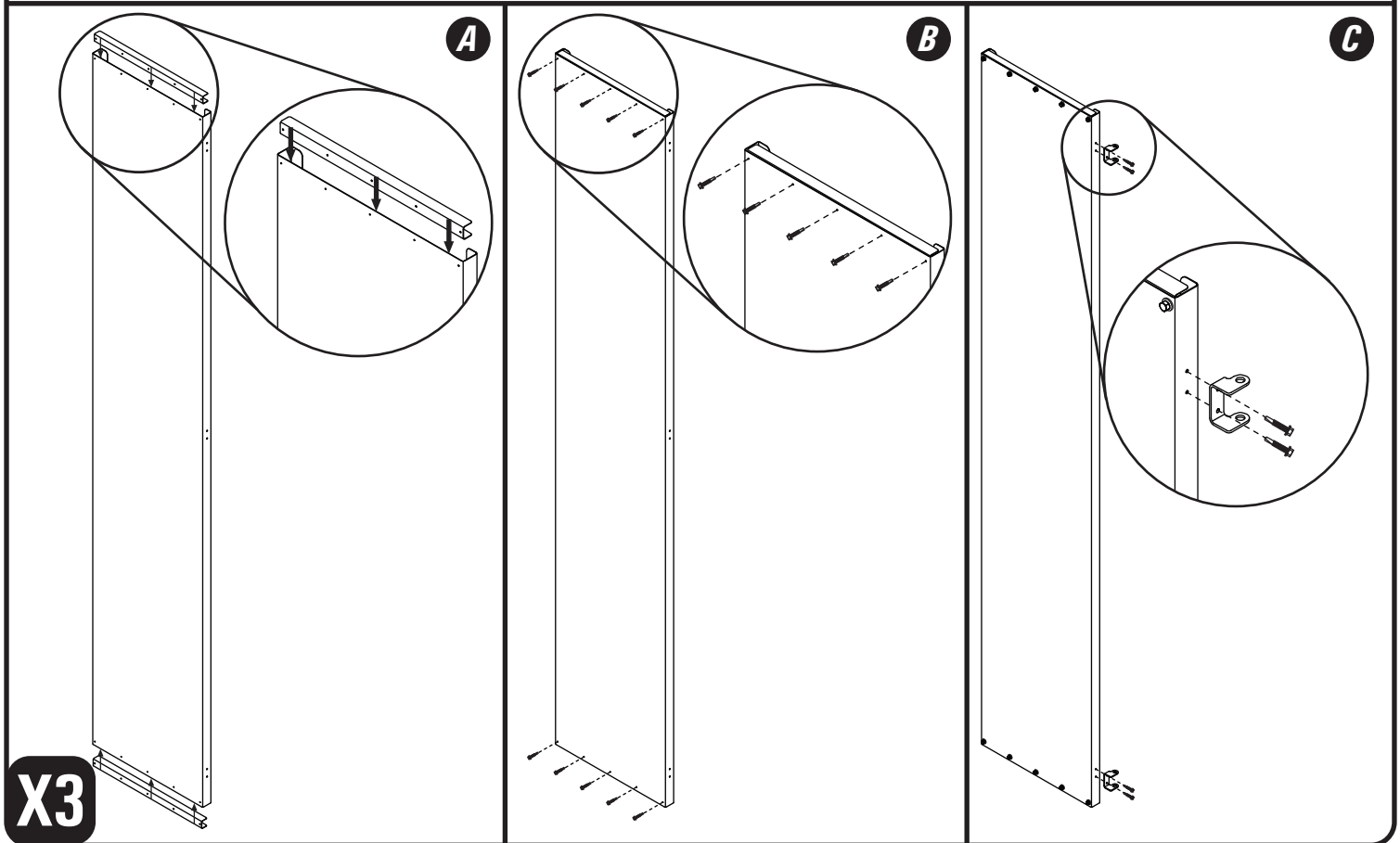

Place door against frame. Using hinge brackets installed in previous step as your guide, attach (2) other hinge brackets and hinge pins to the bracket to verify placement of second hinges on door frame. Secure hinge brackets to frame using (2) 1/4"-14 x 1-1/4" Hex Head Tek Screws per bracket as shown.

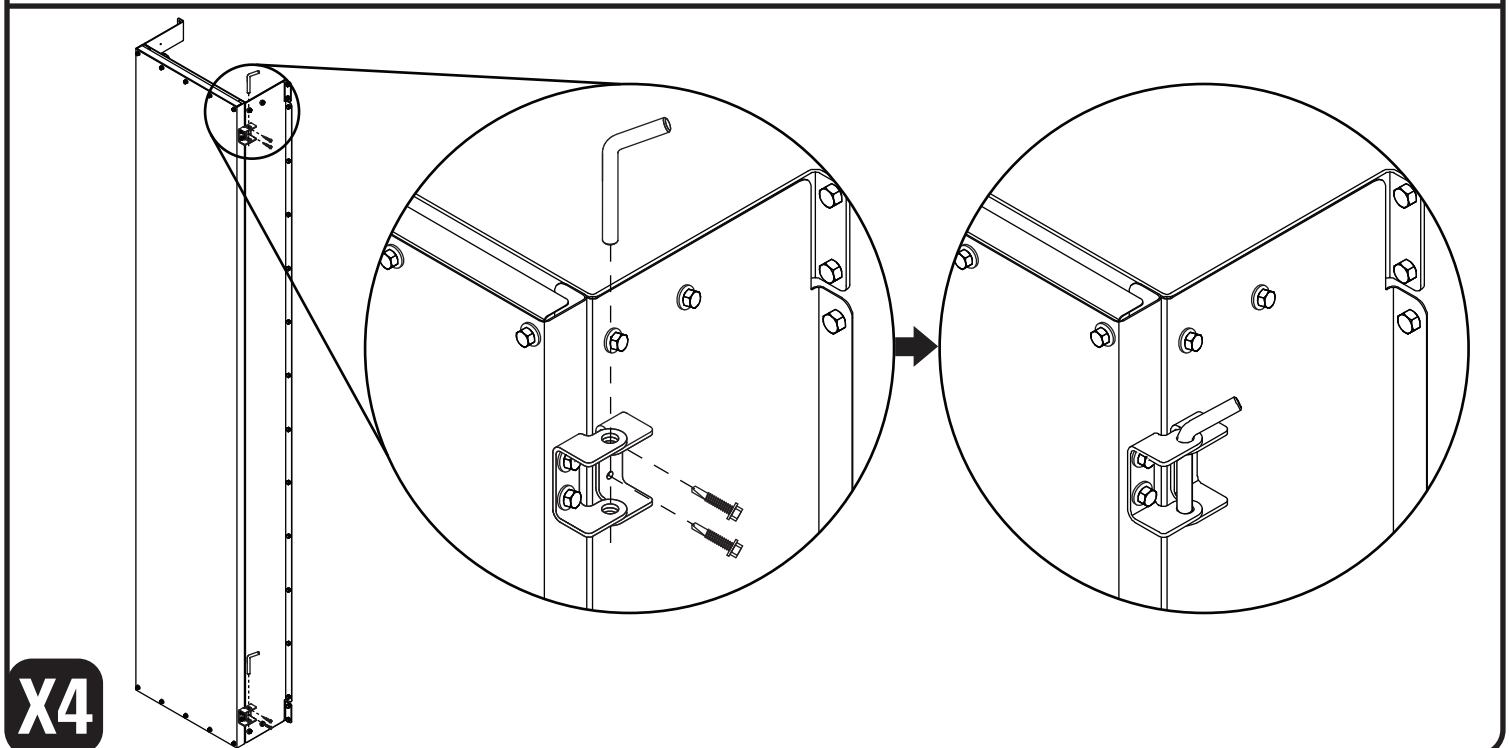

With door closed, secure hinge/latch bracket to frame and door at preferred height using (2) 1/4"-14 x 1-1/4" Hex Head Tek Screws per bracket as shown.

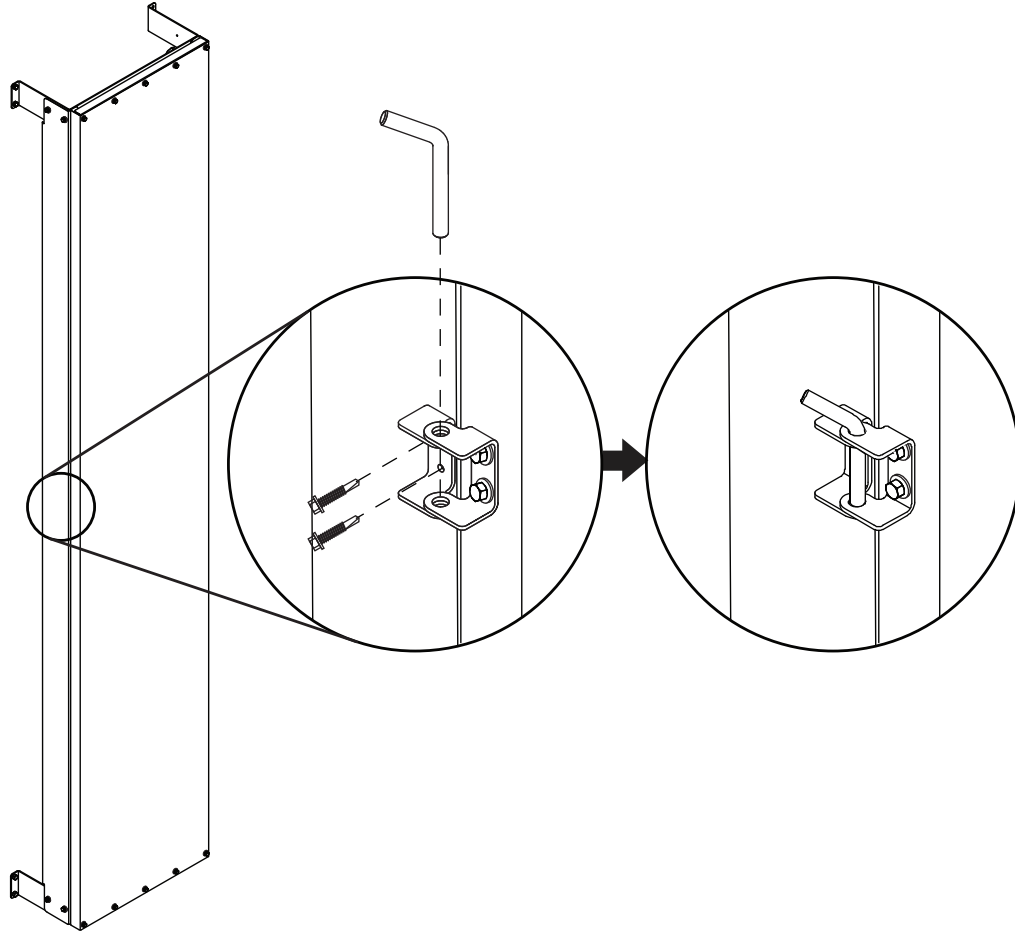

X5

If not installing optional wind pocket cover proceed to Section Z for maintenance and operating instructions.

Measure and mark 1/2" above wind pocket door. Align bottom angled edge with mark made. Secure cover to building using (3) fasteners specific to your building type (refer to **Section B - Page #1** for hardware installation specifications).

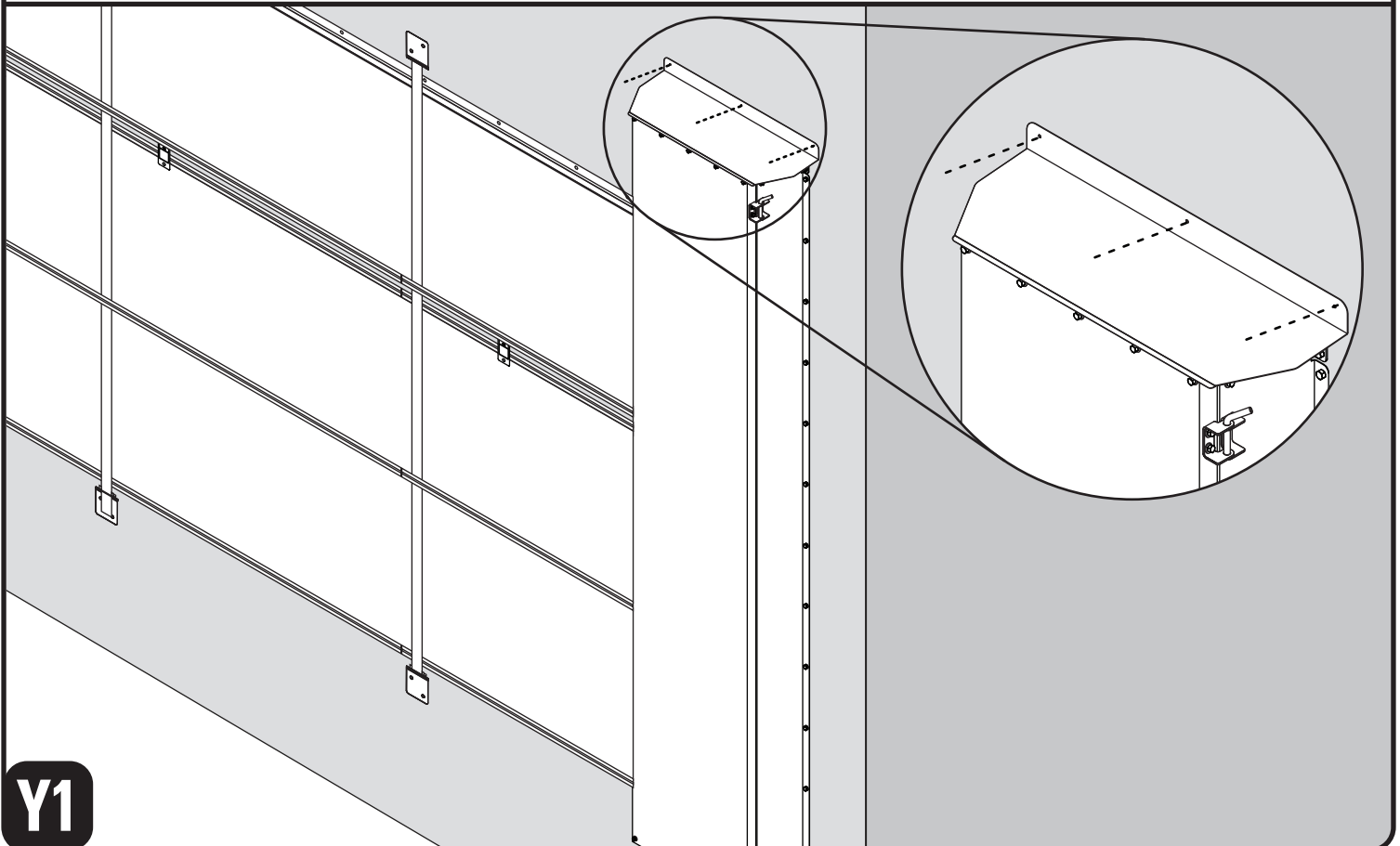
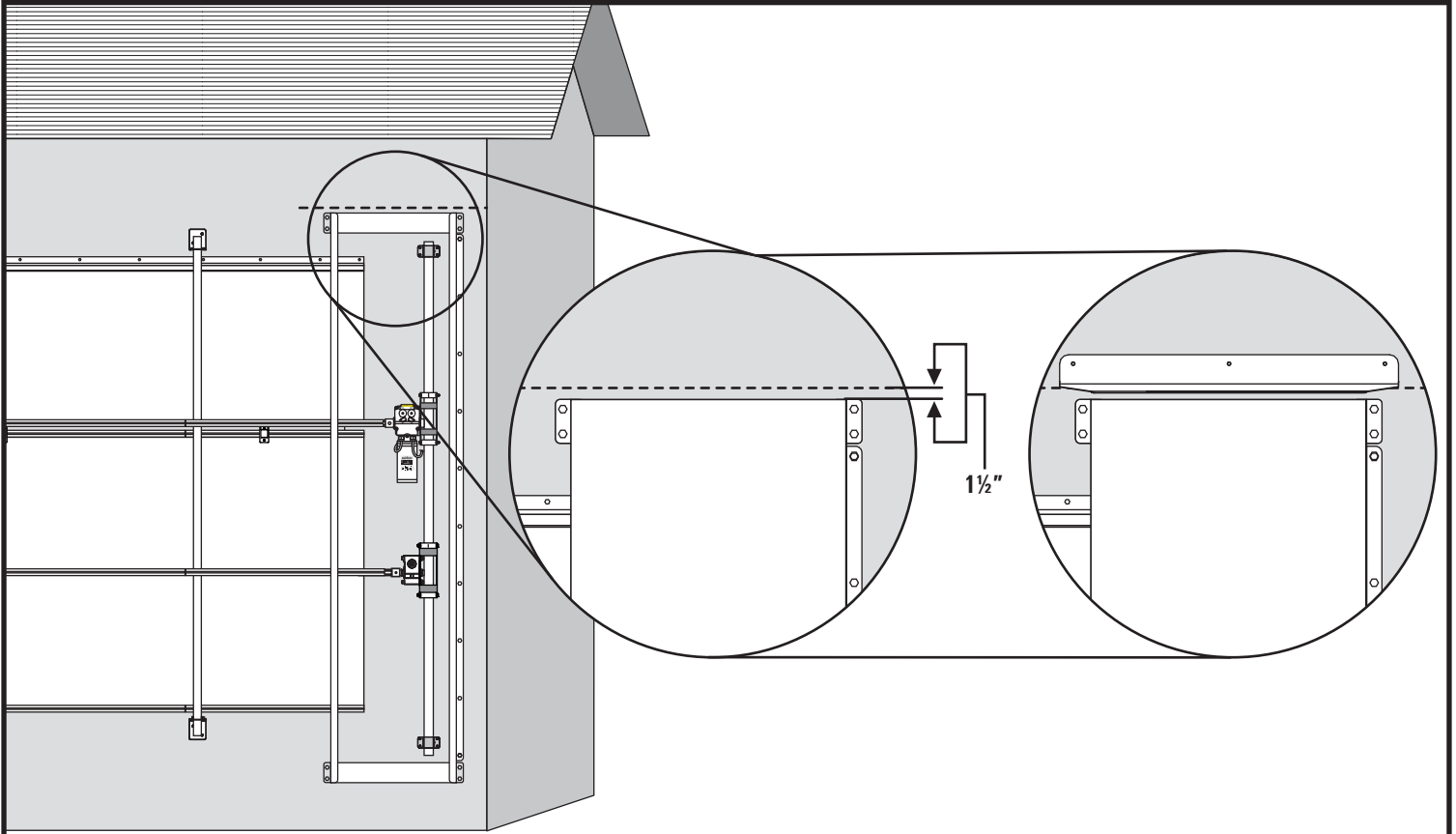

Y1