

# ZP2-HC Installation and Operation Instructions

## 1 Heat / 1 Cool - Auto Changeover - First Call Priority - Time Share

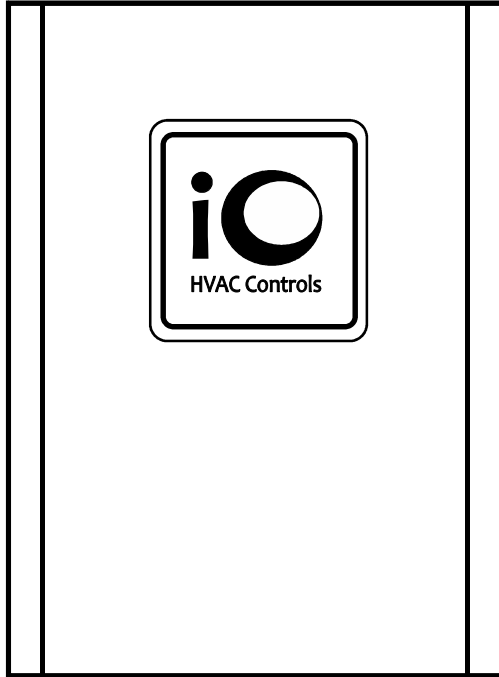

### Sequence of Operation:

The ZP2-HC is a residential / light commercial zone control system that allows a single HVAC unit to have up to two separate zones. Each zone is controlled by its own space thermostat and motorized zone damper. If a zone thermostat calls for heating or cooling, the zone not calling will have its damper powered closed, and the zone calling will have its damper opened. The heating or cooling equipment will also be brought on at the same time. When the zone calling is satisfied, the heating or cooling equipment turns off. If one zone calls for heating and another zone calls for cooling, the first zone to call receives priority. In the event of a tie, cooling will receive priority. When the first call is satisfied, the system will changeover and take care of the opposite call. If a zone being served (heating or cooling) has not been satisfied within 20 minutes and an opposite call takes place, the system will changeover. When the zone is satisfied or 20 minutes has gone by, the system will again changeover if an opposite call exists. This is referred to as Auto Changeover - First Call Priority - Time Share.

### High and Low Limit Protection:

The ZPA-DTS Discharge Temperature Sensor should be mounted on the discharge air plenum of the HVAC unit and wired to the DA terminals on the panel. The sensor is used for both high and low limit protection. The high limit setting can be adjusted using the two slide switches located on the panel. (See switch location and settings on page 2) The low limit is fixed at 45° F. When the discharge air temperature rises above the high limit setting or falls below the low limit setting, the panel will cycle the equipment off while the fan continues to run. The LIMIT LED blinks when high or low limit is reached.

### Ventilation Mode:

Zone ventilation is established by the individual zone thermostat fan setting. Any thermostat set in the fan AUTO mode will have its damper power closed to prevent ventilation air when there are no calls for heating or cooling. Any thermostat set in the fan ON mode will receive ventilation air whenever there are no heating or cooling calls taking place.

### Power Requirements:

The ZP2-HC panel requires a separate 24 VAC transformer to power the panel, thermostats and zone dampers. The VA rating of the transformer will be dependent upon the type and total number of zone dampers being used. Refer to specific damper actuator specifications when calculating the total transformer VA requirement. Any single zone can have multiple dampers wired in parallel providing the total VA rating of the dampers does not exceed 30 VA. If the total number of dampers on a single zone exceed 30 VA, a relay should be used with an additional, properly sized transformer.

### Wiring:

All wiring is done using conventional 18 gauge thermostat wire. Thermostats and zone dampers may be located up to 300 feet from the ZP2-HC panel.

# ZP2-HC Installation and Operation Instructions

## 1 Heat / 1 Cool - Auto Changeover - First Call Priority - Time Share

### LOGIC PANEL WIRING DIAGRAM

#### LED FUNCTIONS

- 24 V** (ON with 24 Vac)
- W** (ON with heating call)
- Y** (On with cooling call)
- G** (On with fan call)
- LIMIT** (ON when sensor is connected - Blinks when out on High or Low limit)
- ZD1** (ON when damper is open)
- ZD2** (ON when damper is open)

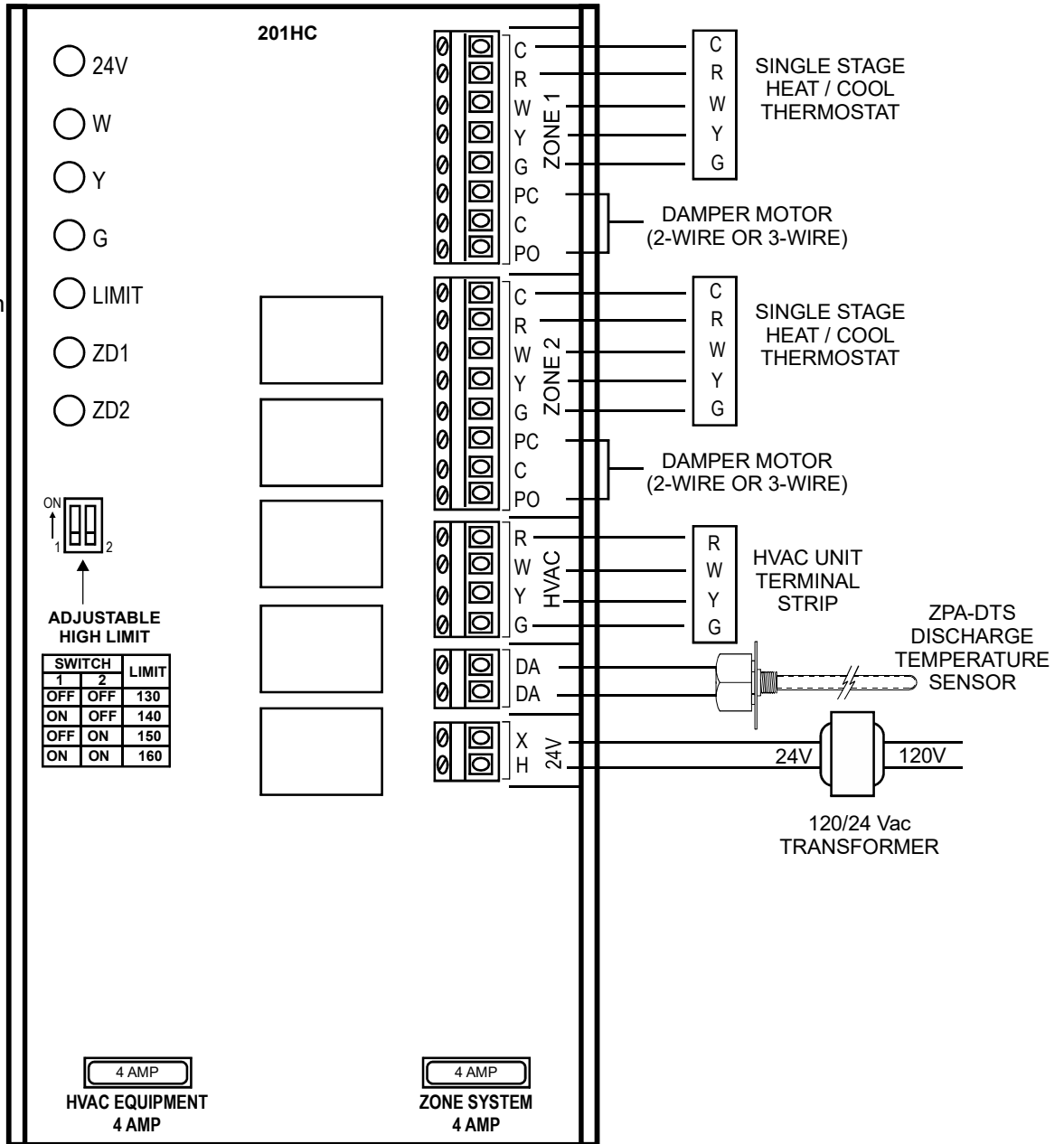

4 Amp fuse protects the relay contacts

4 Amp fuse protects printed circuit board

# ZP2-HC Installation and Operation Instructions

## 1 Heat / 1 Cool - Auto Changeover - First Call Priority - Time Share

### Installation:

#### Mounting the Panel:

Carefully remove the ZP2-HC panel and cover from the shipping carton. Slide the PC board out of the snap track base and mount the base to a flat surface either on or near the HVAC indoor unit in an area that will facilitate easy access for wiring. Reinstall the PC board by carefully centering it over the base and snapping it back into the track groves.

#### Wiring Zone Thermostats and Dampers:

Refer to the logic panel wiring diagram. Wire zone 1 thermostat and its associated damper to the ZONE 1 terminals on the logic panel. Wire zone 2 thermostat and damper in the same manner.

#### Wiring HVAC Equipment:

Wire the HVAC unit to the ZP2-HC HVAC panel terminals. Do not wire the equipment common to the ZP2-HC panel.

#### INSTALLING AND WIRING THE ZPA-DTS DISCHARGE TEMPERATURE SENSOR:

Drill a 15/32" hole in the middle of the main discharge air plenum approximately 18" to 30" from the heat pump electric strip heater or the furnace heat exchanger in a fossil fuel application. Slide the discharge air probe into the hole and use two self-tapping sheet metal screws to secure the base to the plenum. Use conventional 18-2 thermostat wire and wire nuts to attach the sensor leads. Replace the cover with the wire nut connections inside. Strip 1/8" insulation off of each wire at the other end and and the wires to the screw terminals marked DA on the panel.

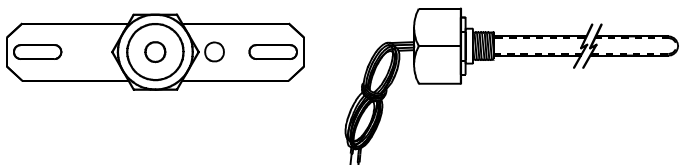

### Wiring the Transformer:

Wire a separate 24 volt transformer of the proper VA to the logic panel terminals marked (X) and (H). Note: Do not power the panel up until all wiring is completed.

### Test, Check and Startup:

1. Verify that all component wires have been connected to the proper terminals and are secure.
2. Disconnect the HVAC equipment (R) terminal wire at the panel and apply 24 Volts to panel. The 24V LED on the panel will light.
3. Use a jumper wire and momentarily short the DA terminals. This will put the panel time delays in "speed up" mode.
4. Place both zone thermostats in the OFF position.
5. The panel accepts 2-wire (power close / spring open) or 3-wire (power open / power close) zone dampers. 2-wire dampers should be wired to the (C) and (PC) terminals.
6. Place zone one thermostat in the fan ON mode. ZD1 LED will remain on and ZD2 LED will go out. The (G) FAN LED will come on.
7. Confirm that zone one damper is in the open position and zone two damper is closed.
8. Leave zone one thermostat in fan ON and place zone two thermostat in the fan ON mode. ZD2 LED will come on.
9. Confirm that both zone one and zone two dampers are in the open position.
10. Place both zone thermostats in the Auto fan mode.
11. Remove 24 Volts to the panel and reconnect the HVAC (R) wire.
10. When 24 Volts is applied again to the panel, the internal time delays will be activated.
11. Place zone thermostats in proper mode of operation.
12. Confirm that the LIMIT LED is ON. If not, check LIMIT wiring. If the system goes out on high or low limit, the LIMIT LED will blink.

# ZP2-HC Installation and Operation Instructions

## 1 Heat / 1 Cool - Auto Changeover - First Call Priority - Time Share

### Specifications:

#### Panel Dimensions:

Height: 8.0 Inches  
Width: 6.0 Inches  
Depth: 1.375 Inches

#### Mounting:

Snap Track with 2 back plate screws

#### Operating Temperature Rating:

-40° F to 150° F

#### Operating Humidity:

5% to 90% RH non-condensing

#### Wiring:

18-gauge wire for all equipment  
and system connections

#### Time Delays:

3 minutes minimum off between  
cooling calls  
3 minutes minimum off on low limit  
20 minute time share

#### Thermostats:

Single-stage heat / cool thermostats  
Programmable or non-programmable  
Auto or manual changeover

### Terminal Designations:

#### Thermostats:

C 24Vac (Common)  
R 24Vac (Hot)  
W Heat  
Y Cool  
G Fan

#### Dampers:

PC Powered Close  
C Common  
PO Powered Open

#### High / Low Limit:

DA Discharge Temperature Sensor (2 wire)  
DA

#### HVAC Equipment:

R 24Vac (Hot)  
W Heat  
Y Cool  
G Fan

#### Panel Power:

X 24Vac (Common)  
H 24Vac (Hot)

### Typical System Layout

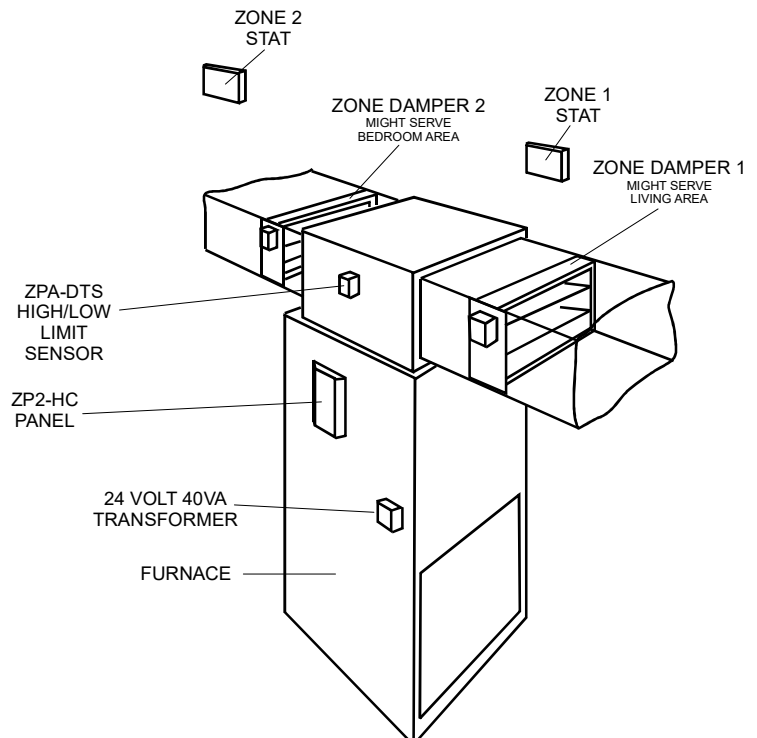

[www.iohvaccontrols.com](http://www.iohvaccontrols.com)  
For Technical Support Call Toll Free: 866-225-5032