

# iO-LL LEAD/LAG CONTROLLER



## INSTALLATION INSTRUCTIONS

## INTRODUCTION

The iO-LL is a versatile, 24VAC powered lead/lag controller offering true dual-stage control to balance the operating run time between HVAC equipment as well as other redundant devices. The controller has dedicated terminals for 24VAC power, 2 inputs and 2 outputs. LEDs provide visual indication for power and output status.

## SEQUENCE OF OPERATION

When 24 volt power is first applied to the 24VAC terminals 7 and 8 on the iO-LL, Unit 1 and Unit 2 output contacts remain open. When 24 volts is applied to input terminal 1, Unit 1 output contacts go closed and Unit 2 contacts remain open. When 24 volts is removed from terminal 1 for at least 10 seconds, Unit 1 output contacts open. When 24 volts is reapplied to terminal 1, Unit 1 output contacts remain open and Unit 2 output contacts go closed. The lead/lag sequence is reversed every time 24 Volts is removed from terminal 1 for more than 10 seconds and then reapplied.

In a dual stage application, 24 volts applied to terminal 2 will close the lag output contacts. As long as 24 volts is maintained on terminal 1, the lag output can be cycled on and off.

The iO-LL Lead/Lag Controller must be powered from the same 24 volts as Unit 1 control circuit or a relay will be required.

## WIRING DIAGRAMS

The wiring diagrams illustrated in this installation manual represent a sampling of the many ways the iO-LL can be applied for lead/lag control.

**The iO-LL is an operating controller only and depending on the application, it is the responsibility of the installer to verify that the iO-LL complies with all electrical and/or plumbing codes.**

SPECIFICATIONS	
<b>Input:</b>	<b>24VAC</b>
<b>Frequency:</b>	<b>60/60 Hz</b>
<b>Contact Rating:</b>	<b>12 Amps @ 24VAC</b>
<b>PC Board Dimensions:</b>	<b>3.25" W x 5.5" H Mounted on Snap-Track</b>
<b>Controller With Optional Enclosures:</b>	<b>iO-LLME with metal enclosure iO-LLWPE with weather-proof plastic enclosure</b>

# iO-LL

## LEAD/LAG CONTROLLER

### STAND ALONE APPLICATIONS

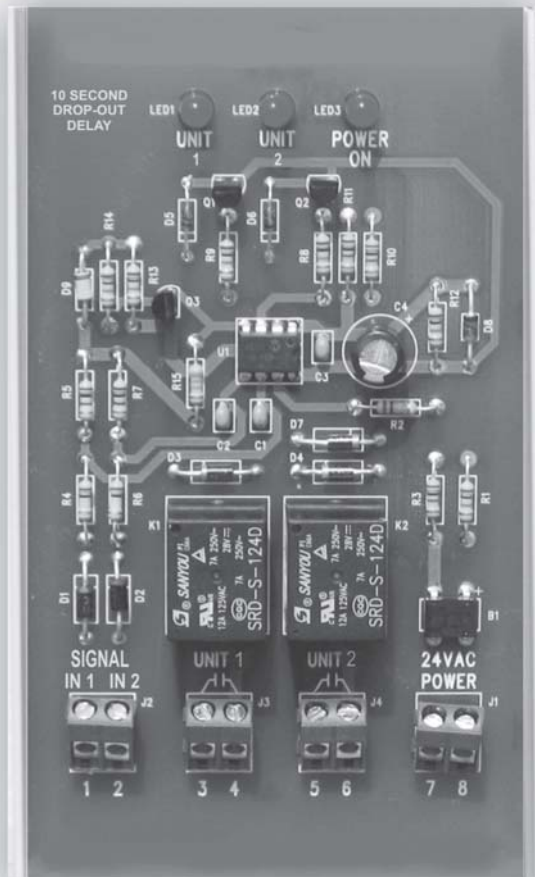

TYPICAL WIRING DIAGRAMS

# WIRING DIAGRAM USING iO-LL LEAD/LAG CONTROLLER WITH SINGLE-STAGE COOLING UNITS IN PARALLEL

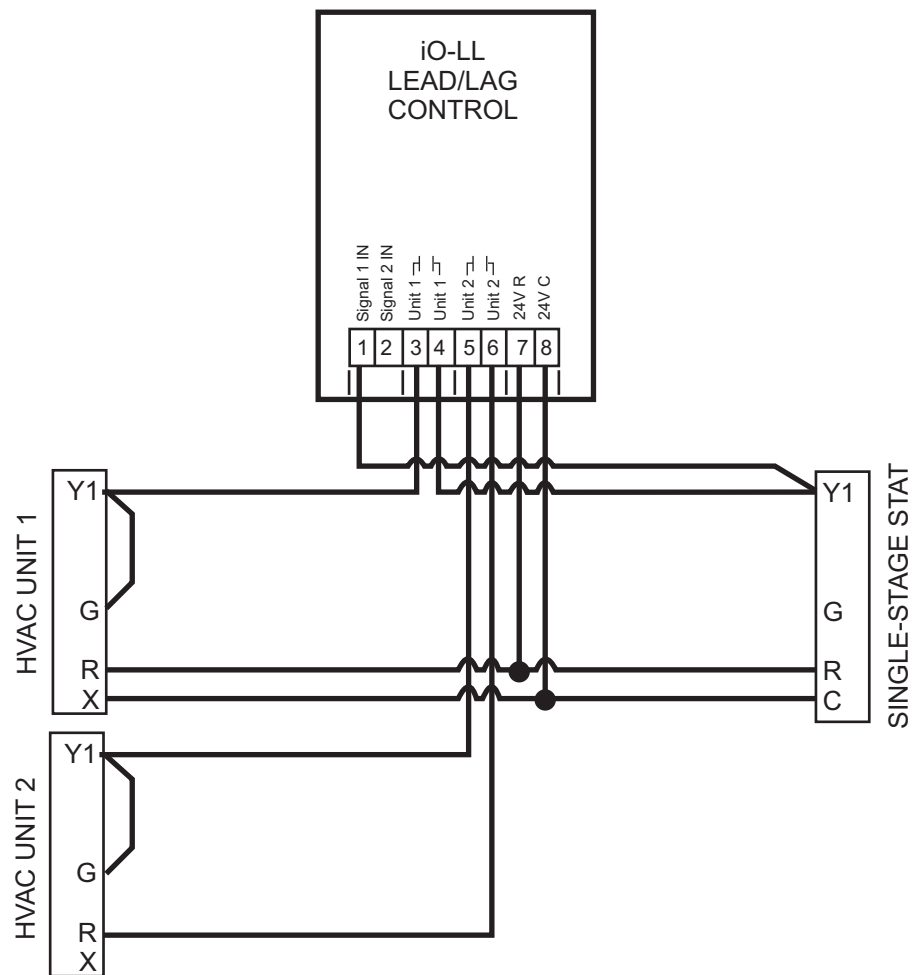

# WIRING DIAGRAM USING iO-LL LEAD/LAG CONTROLLER WITH SINGLE-STAGE COOLING UNITS IN PARALLEL WITH UPSTAGING

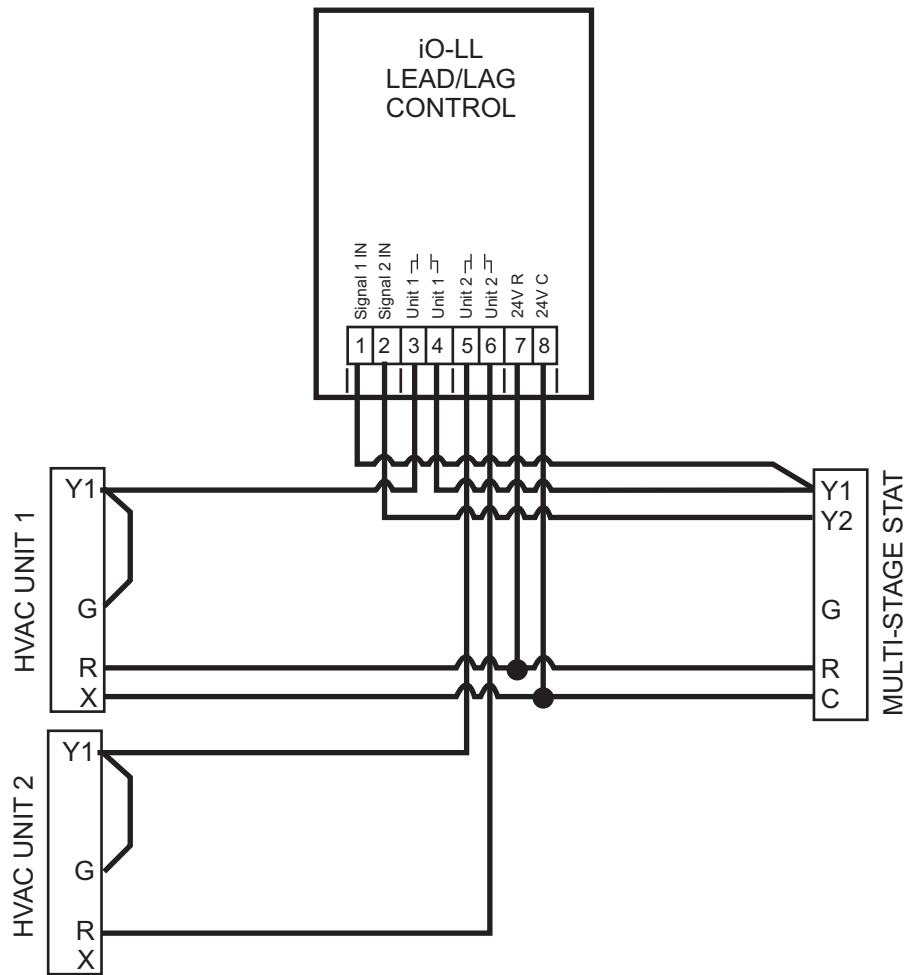

# WIRING DIAGRAM USING iO-LL LEAD/LAG CONTROLLER FOR 2 PUMP SYSTEM WITH A FLOW SWITCH TO TRIGGER LEAD/LAG

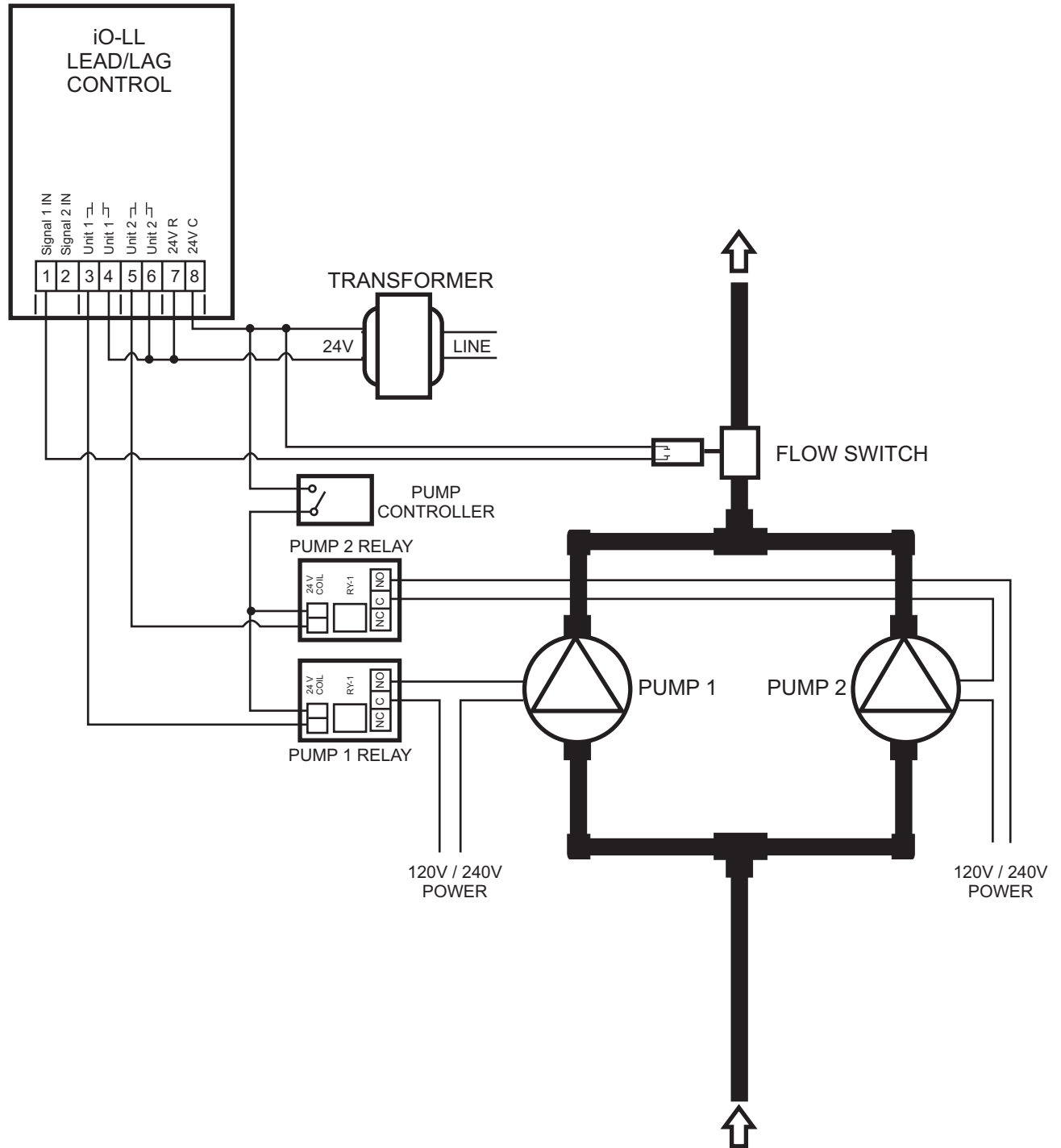

# WIRING DIAGRAM USING iO-LL LEAD/LAG CONTROL FOR 2 PUMP SYSTEM WITH A RELAY TO TRIGGER LEAD/LAG

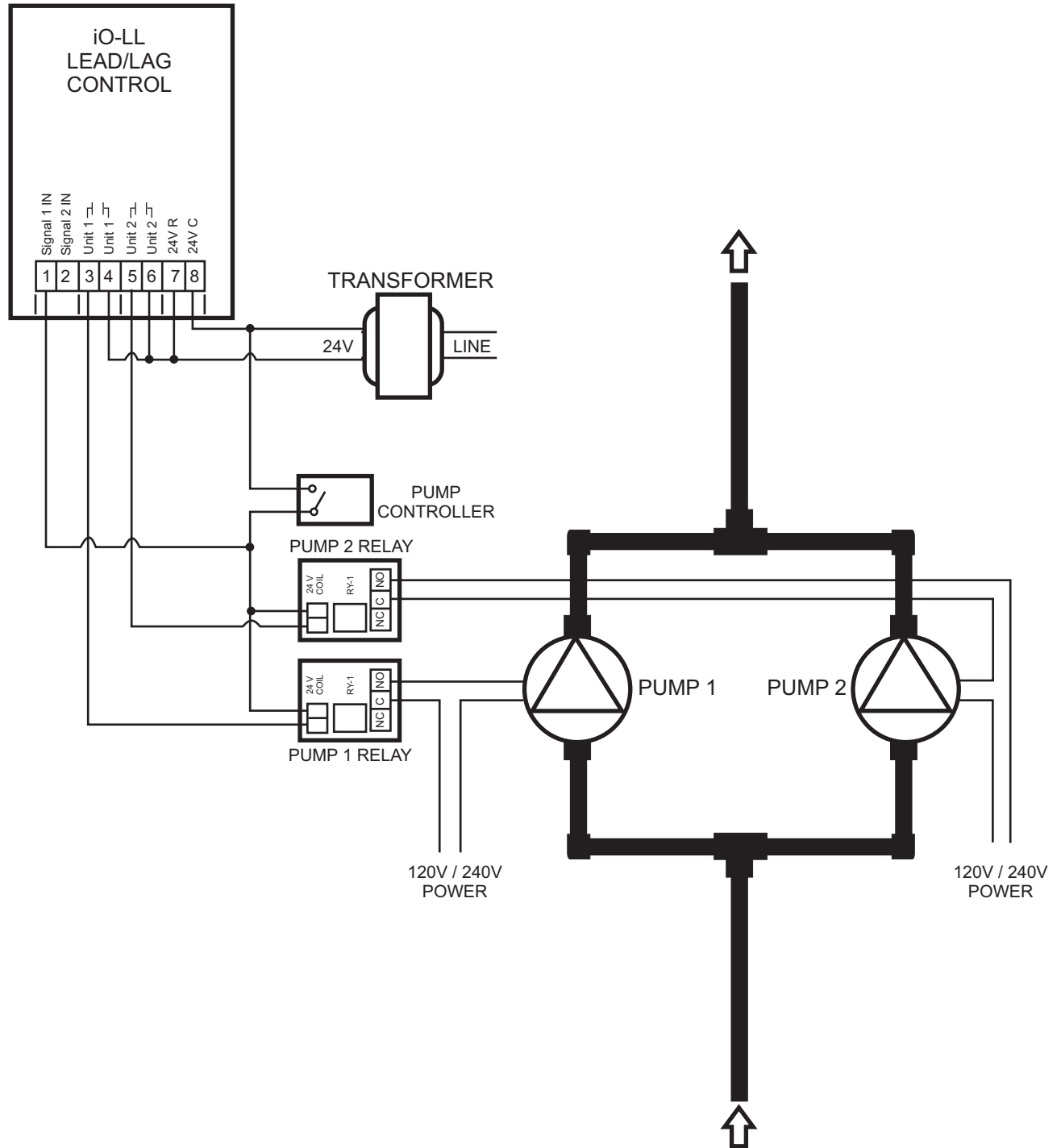





# iO-LL

## LEAD/LAG CONTROLLER

### USED WITH iO-TWIN TWINNING AND PARALLELING KIT

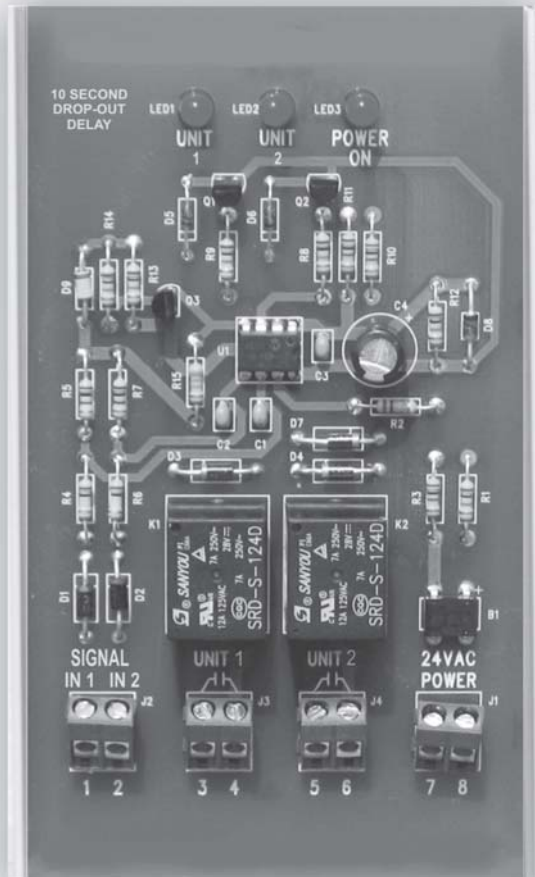

TYPICAL WIRING DIAGRAMS

# WIRING DIAGRAM USING iO-LL LEAD/LAG CONTROLLER AND iO-TWIN TWINNING KIT FOR COOLING LEAD/LAG

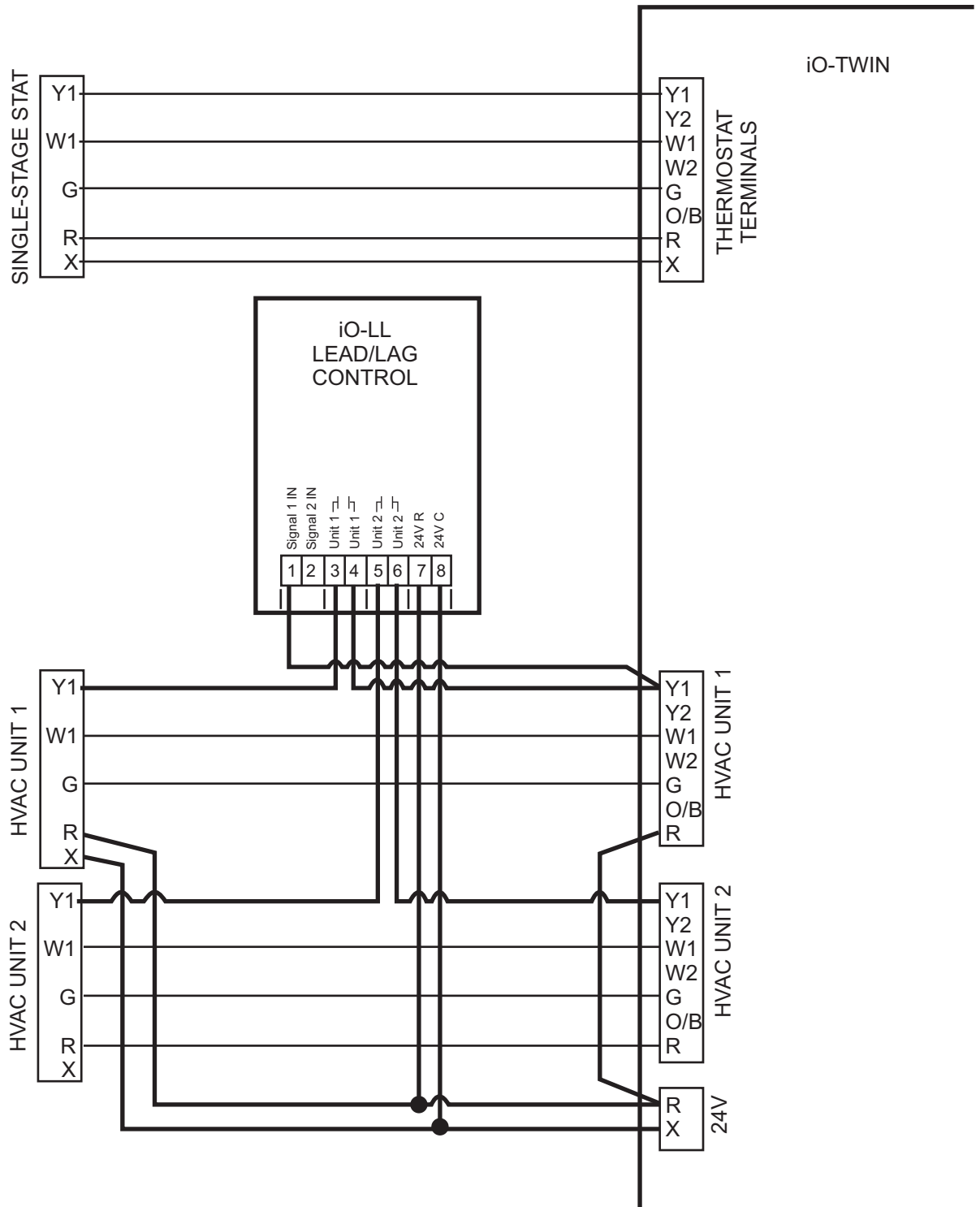

# WIRING DIAGRAM USING iO-LL LEAD/LAG CONTROLLER AND iO-TWIN TWINNING KIT FOR COOLING LEAD/LAG WITH UPSTAGING

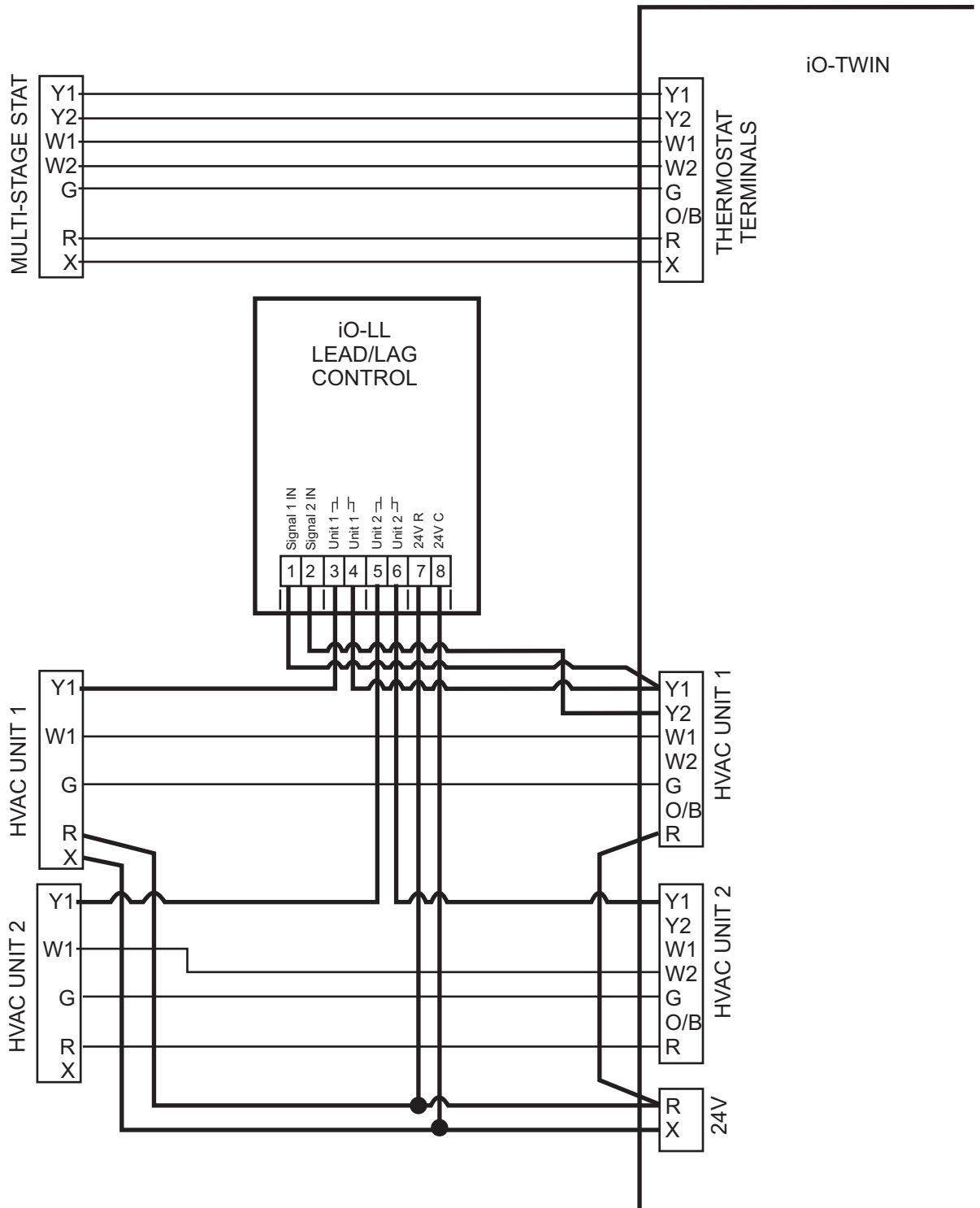

# WIRING DIAGRAM USING iO-LL LEAD/LAG CONTROLLER AND iO-TWIN TWINNING KIT FOR HEATING LEAD/LAG

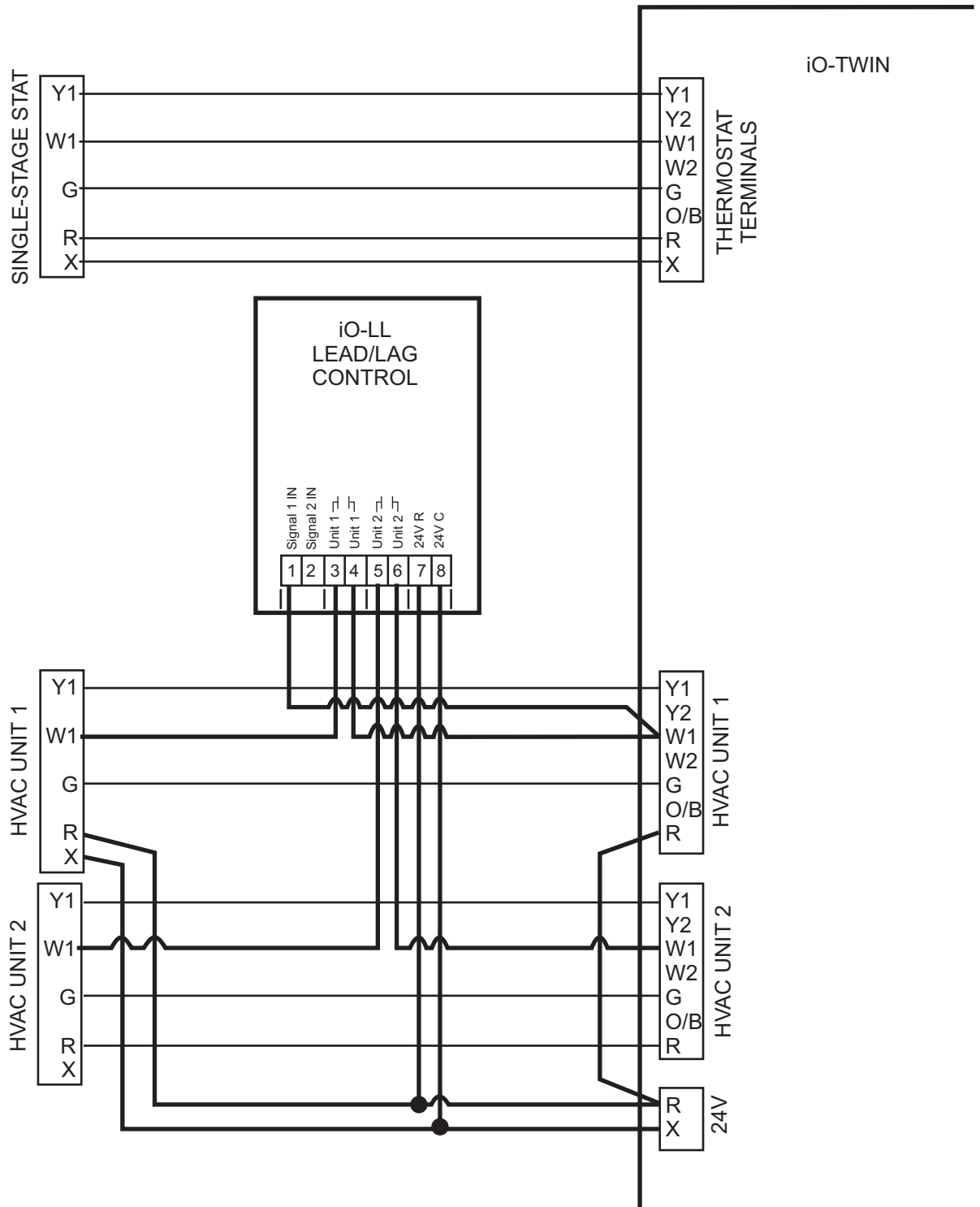

# WIRING DIAGRAM USING iO-LL LEAD/LAG CONTROLLER AND iO-TWIN TWINNING KIT HEATING LEAD/LAG WITH UPSTAGING

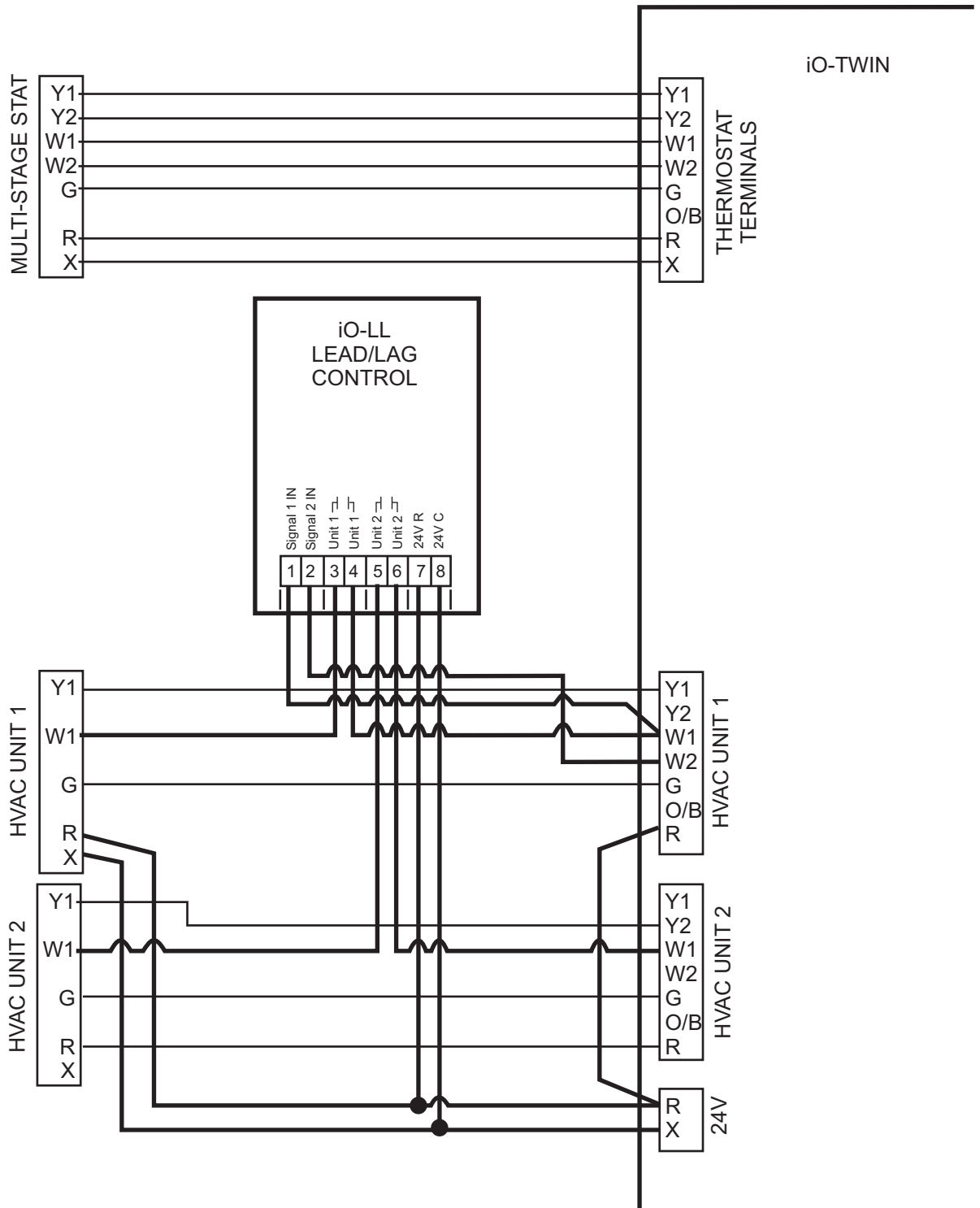

# WIRING DIAGRAM USING iO-LL LEAD/LAG CONTROLLERS AND iO-TWIN TWINNING KIT FOR HEATING AND COOLING LEAD/LAG

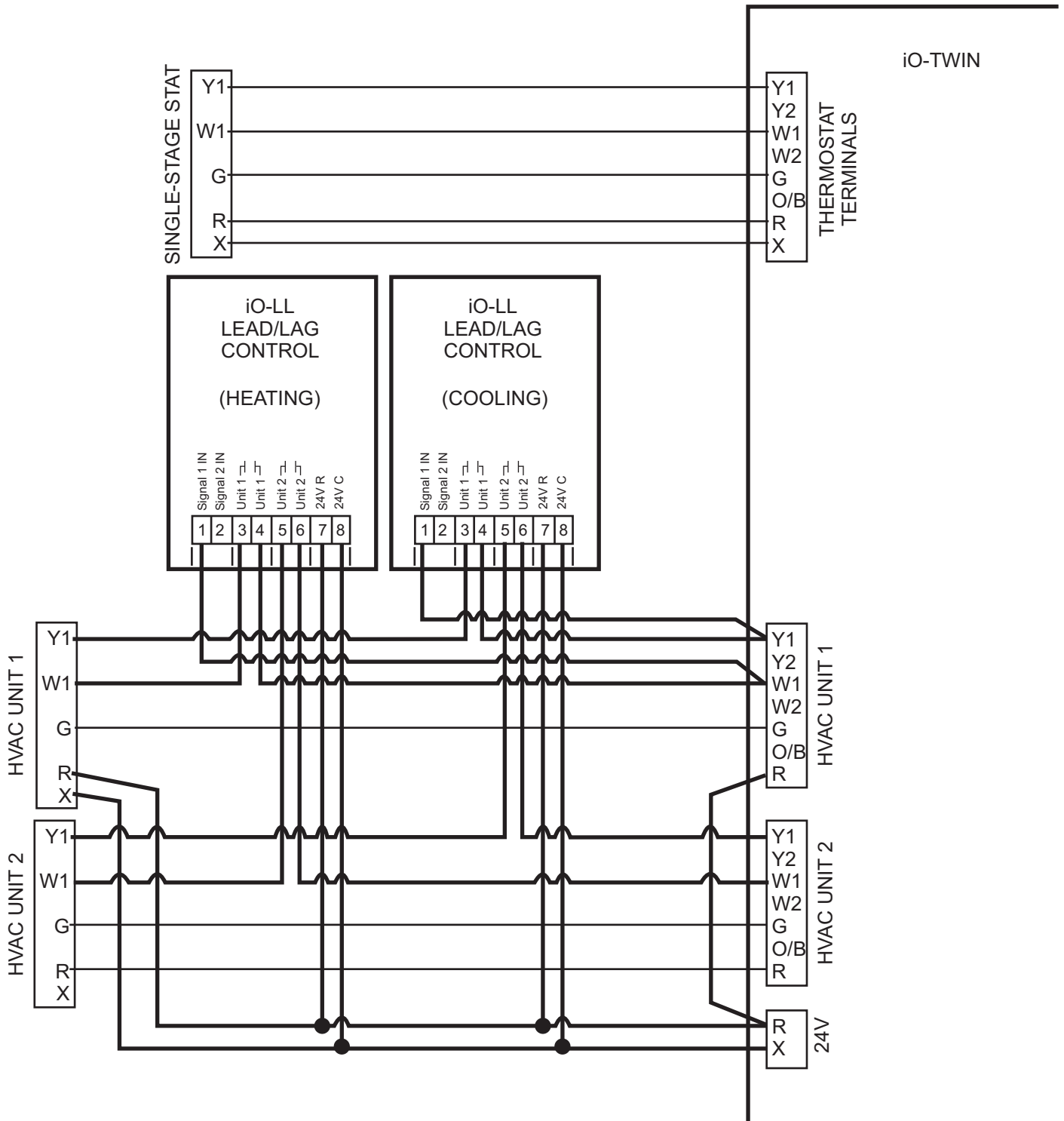

# WIRING DIAGRAM USING iO-LL LEAD/LAG CONTROLLERS AND iO-TWIN TWINNING KIT FOR HEATING AND COOLING LEAD/LAG WITH UPSTAGING

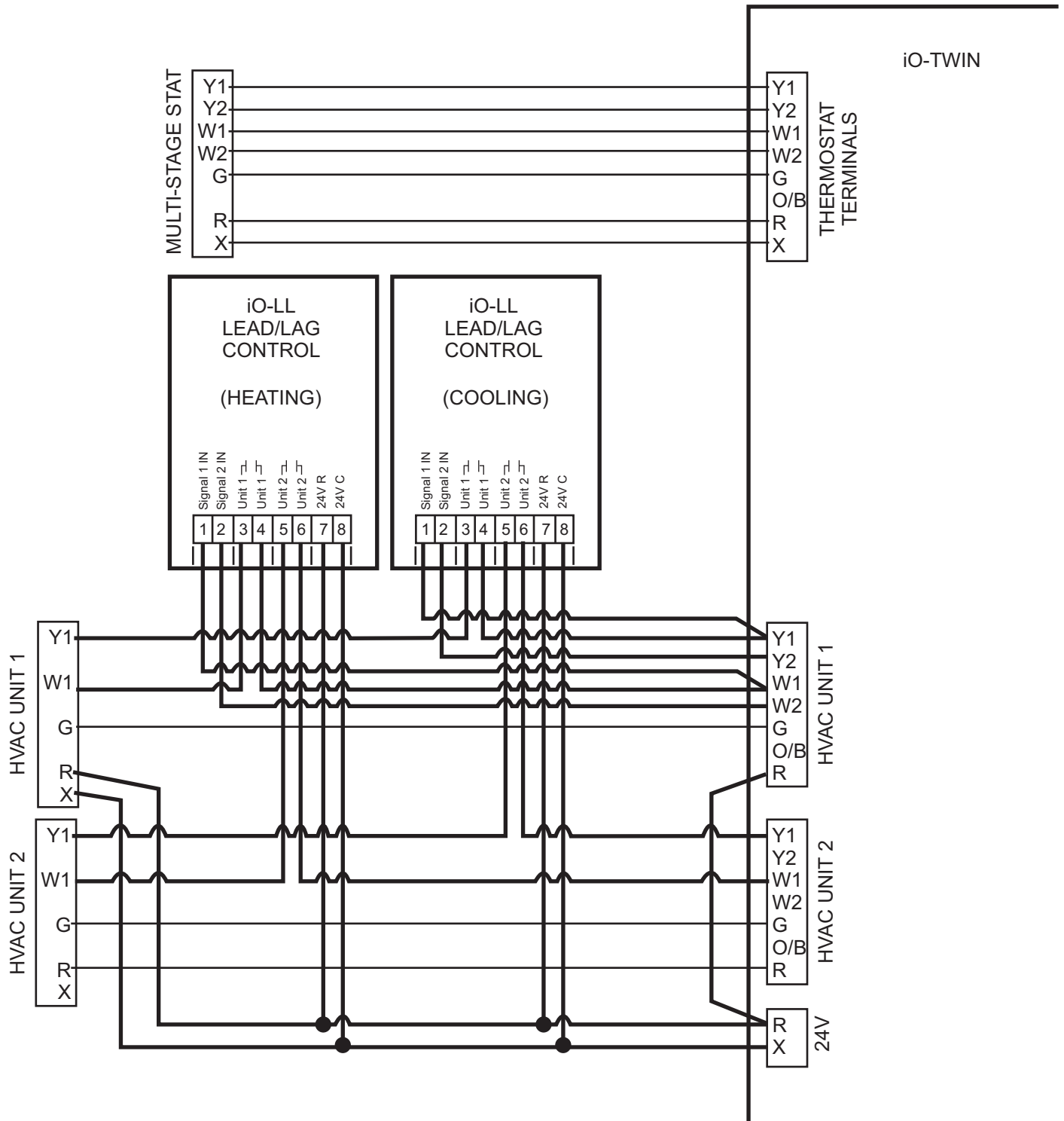

# WIRING DIAGRAM USING iO-LL LEAD/LAG CONTROLLERS AND iO-TWIN TWINNING KIT FOR 1 HEAT / 1 COOL HEAT PUMP

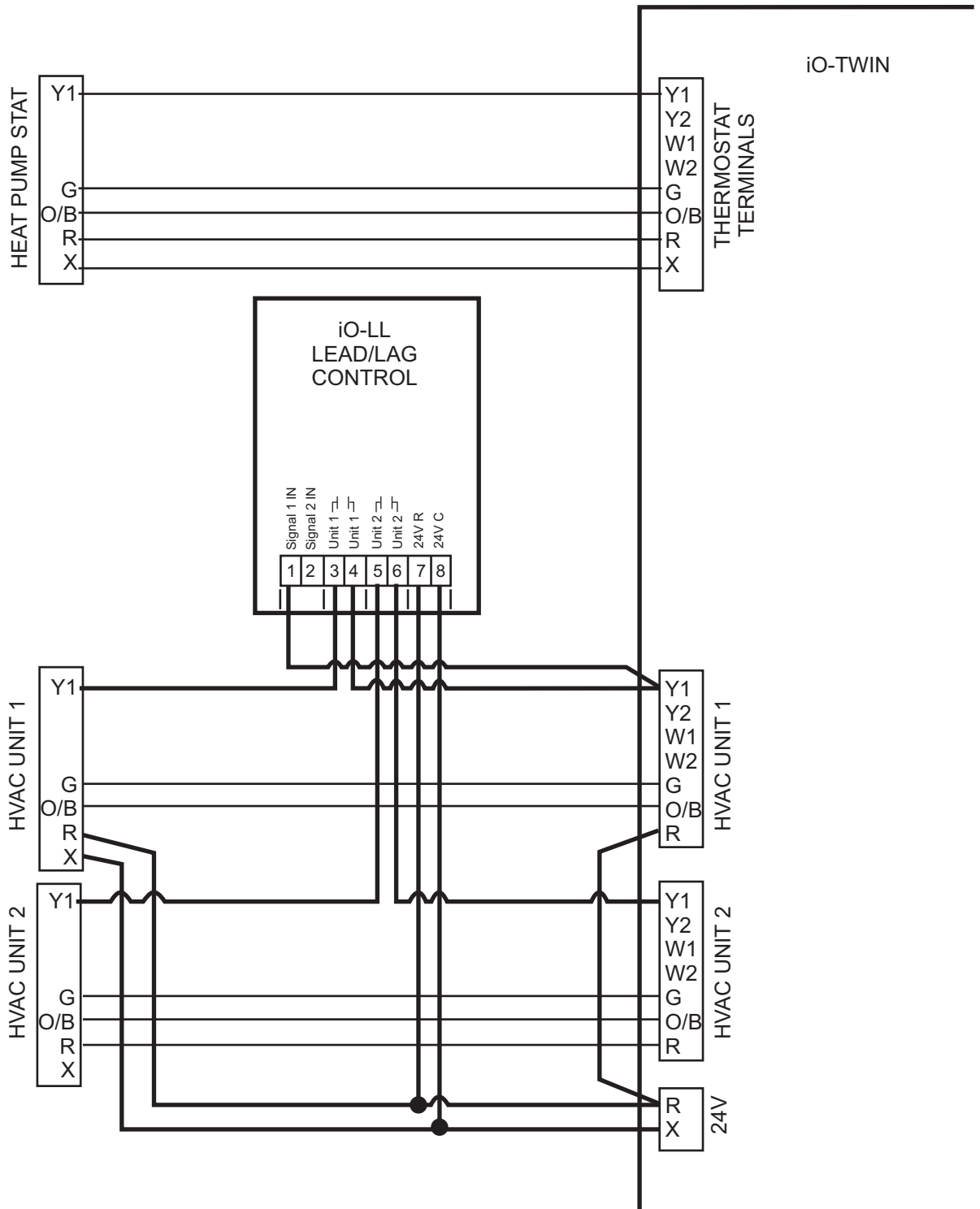



# WIRING DIAGRAM USING iO-LL LEAD/LAG CONTROLLERS AND iO-TWIN TWINNING KIT FOR 1 HEAT / 1 COOL HEAT PUMP WITH UPSTAGING

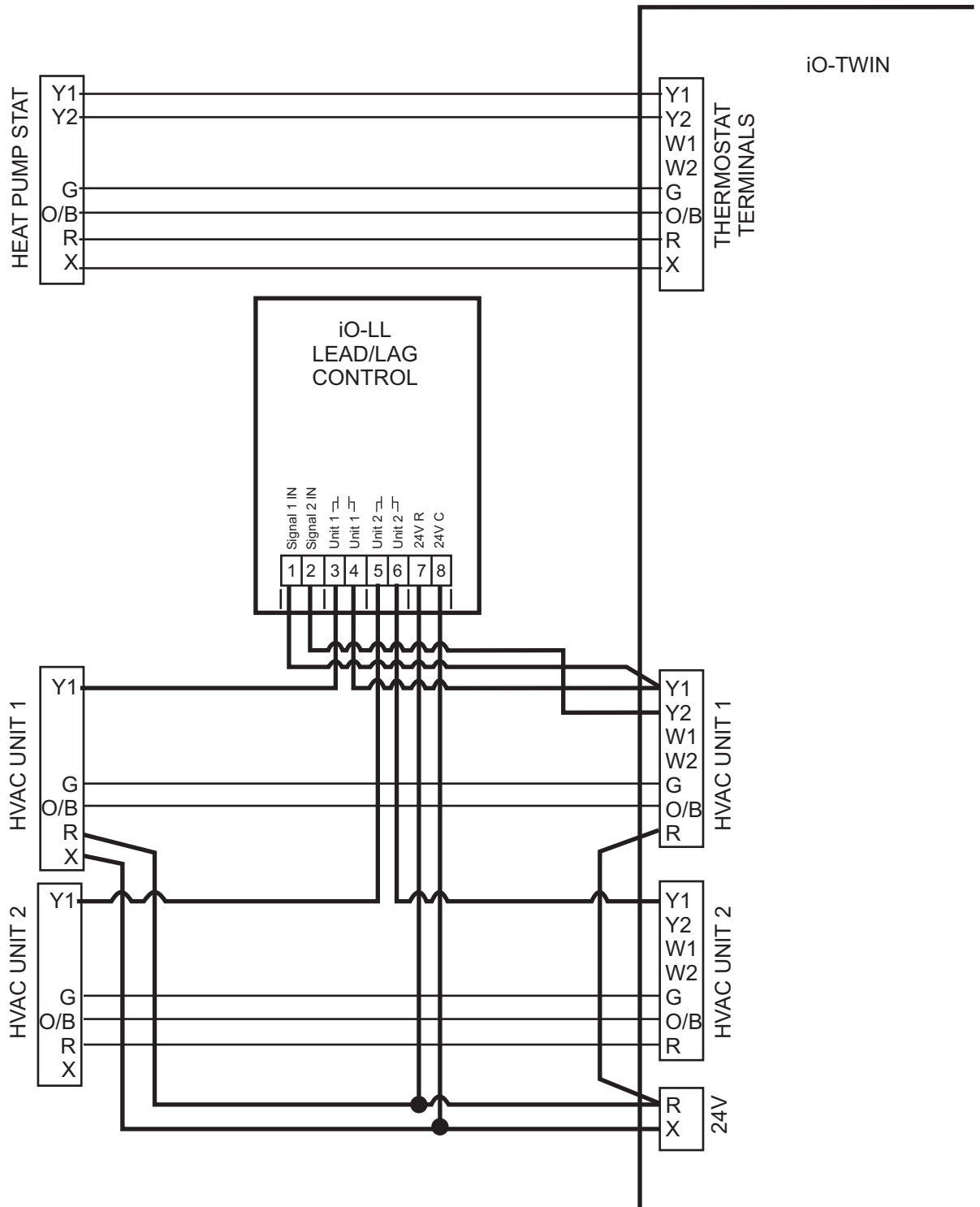

# WIRING DIAGRAM USING iO-LL LEAD/LAG CONTROLLERS AND iO-TWIN TWINNING KIT AND RY-2 DPDT RELAY FOR 2 HEAT / 1 COOL HEAT PUMP

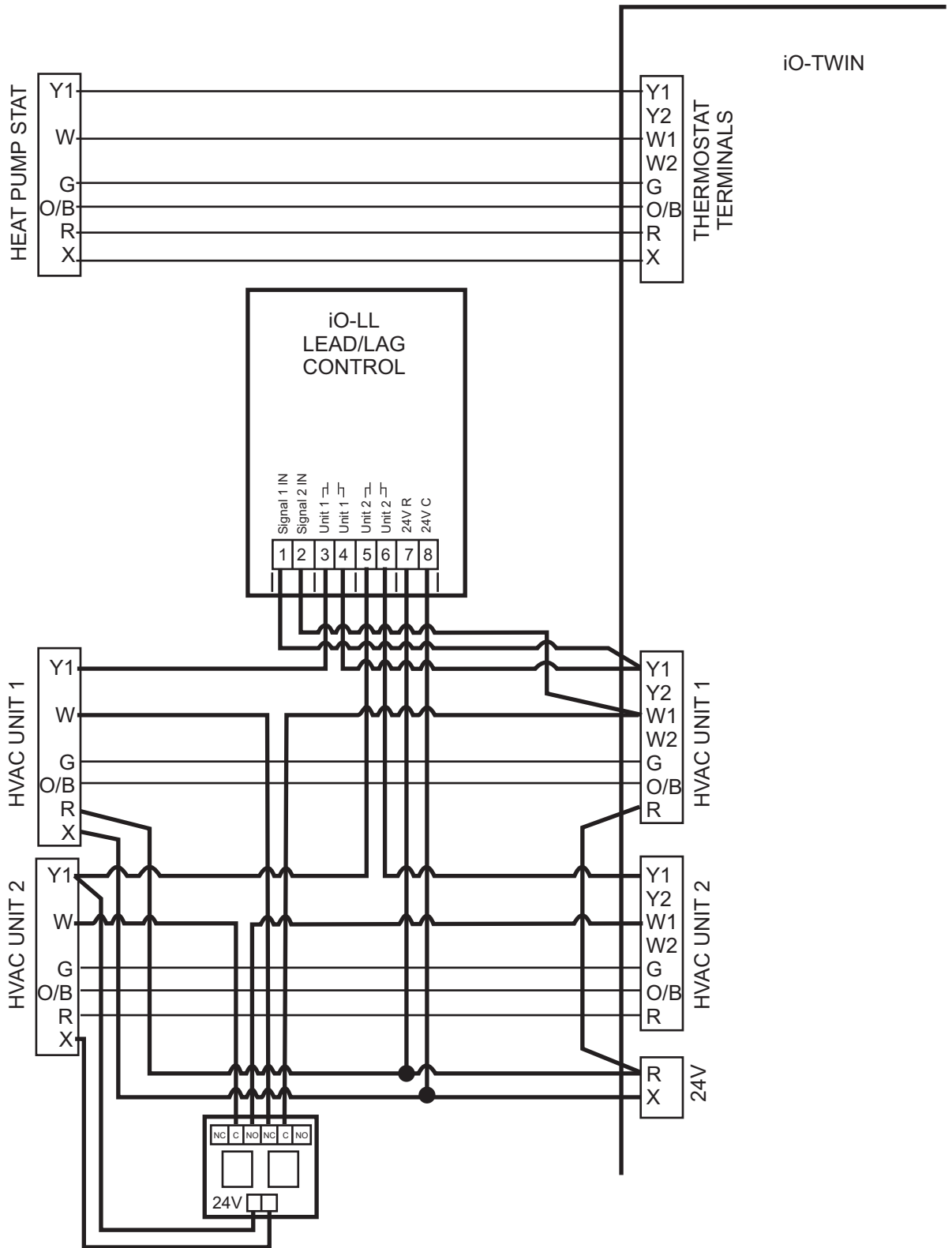

# WIRING DIAGRAM USING iO-LL LEAD/LAG CONTROLLERS AND iO-TWIN TWINNING KIT FOR 2 HEAT / 1 COOL HEAT PUMP WITH UPSTAGING (Auxiliary / EH Heat Work Together)

