

CB-KIT

Installation Instructions

APPLICATION:

The CB-KIT is a universal actuator kit that is designed to replace actuators used with Carrier® Infinity™ and Bryant® Evolution™ zone dampers when used with other zone control panels requiring a 3-wire actuator with overload protection that allows the actuator to remain energized at the end of travel while maintaining full rated torque. The CB-KIT is compatible with Carrier® and Bryant® round, rectangular side mount and rectangular bottom mount dampers.

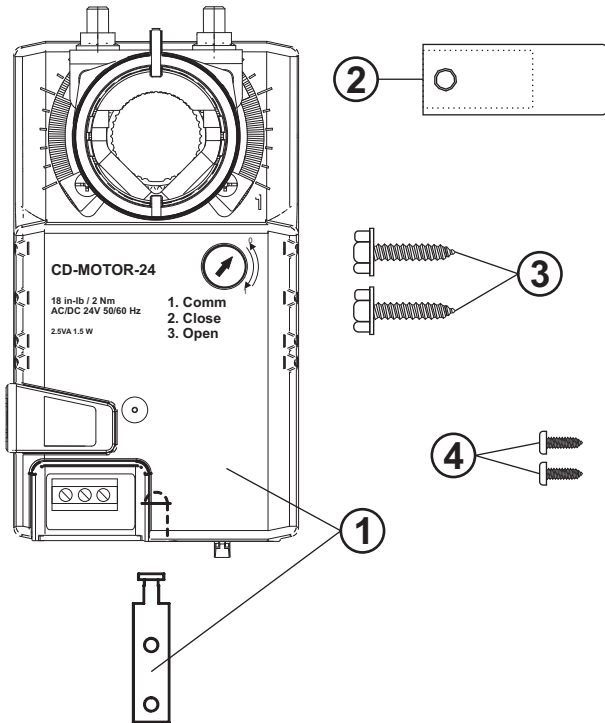

CB-KIT CONTENTS:		
ITEM	PART NUMBER	DESCRIPTION
1	CD-MOTOR-24	3-Wire 24VAC Actuator with Universal Mounting Bracket
2	RETRO-CPL-CAR-DMPR	1-1/2" x 5/8" Dia. Aluminum Shaft Adapter with 10-32 x 1/4" Socket Cut Point Set Screw
3	8N50UHWZ	#8 x 1/2" Hex Washer Self-Tapping Tek Screw (2)
4	8C25TXPZ/F	8-32 x 1/4" Philips Pan Type F Screw (2)

GETTING STARTED:

Tools you will need:

- Electric drill
- 3/32" Allen wrench
- 1/8" Drill bit
- 5/16" Nut driver or small adjustable crescent wrench
- Philips head screwdriver
- 1/4" Hex drive bit

Dampers that have already been installed will have to have the Carrier® or Bryant® actuators removed. If dampers are easily accessible, it may not be necessary to remove them from the duct in order to replace the actuators. The CB-KIT contains all the necessary mounting hardware for attaching the actuator to a round, side mount or bottom mount damper. Take time to review the mounting instructions for each configuration.

MOUNTING INSTRUCTIONS FOR ROUND DAMPERS

1. The RETRO-CPL-CAR-DMPR shaft adapter is not required for mounting the actuator to a round damper.
2. Round damper blades are elliptical, so they do not open and close on a 90° rotation. The actuator has mechanical adjustment stops that can be used for minimum and maximum position settings.
3. The damper blade shaft also has a blade position arrow. When the arrow is aligned with the direction of air flow, the damper blade is in the open position.

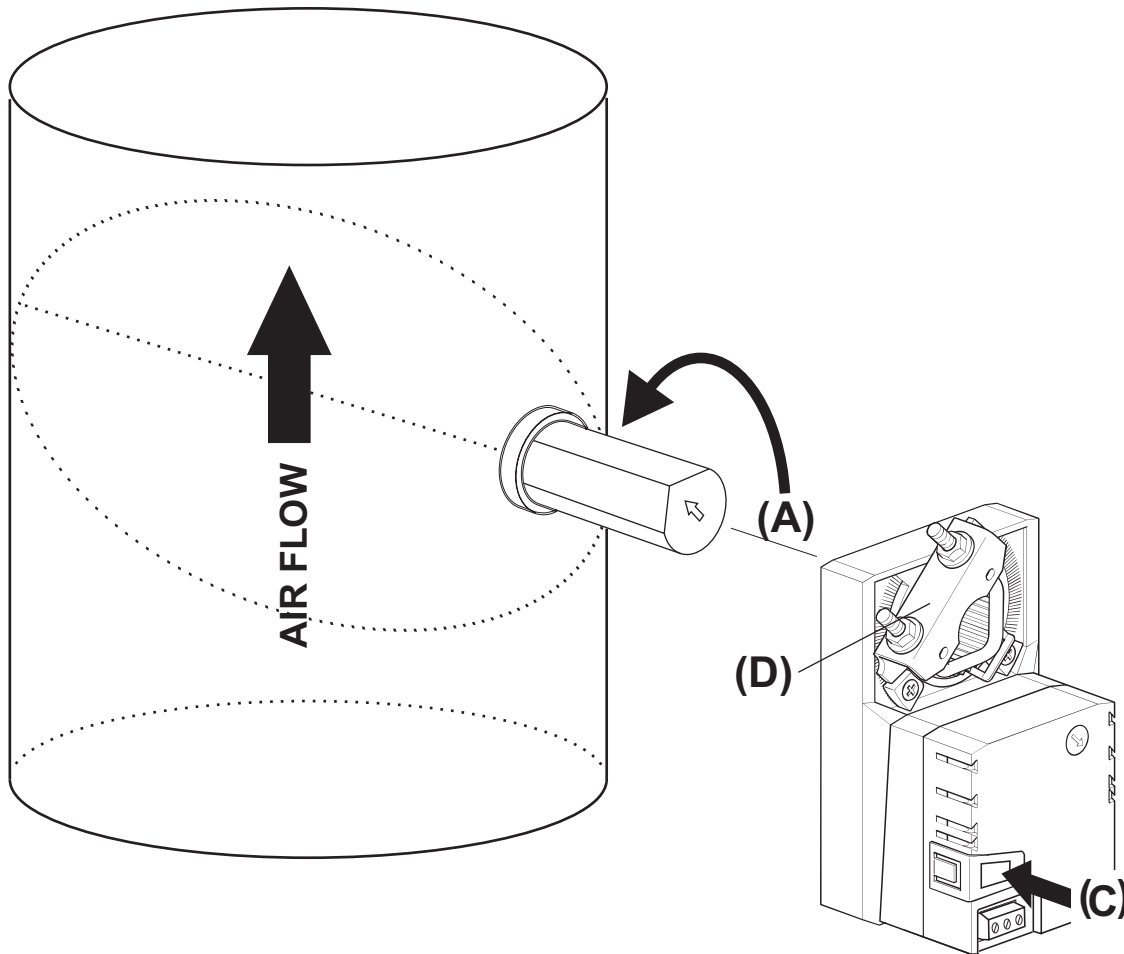

4. Rotate the damper shaft (A) counter clockwise until it comes to a stop.
5. Push in on the actuator clutch (C) and rotate the collar (D) counter clockwise until it hits the mechanical adjustment stop.
6. Slide the actuator over the damper shaft and evenly tighten the two nuts located on the actuator locking collar (E) making sure the shaft is stopped in the counter clockwise position and that the actuator is parallel with the damper shell.
7. Once the locking collar is firmly tightened over the shaft, slide the universal mounting bracket (F) into the slot on the bottom of the actuator and secure using two (2) #8 x 1/2" hex washer self-tapping tek screws.
8. When the actuator is secure, push in on the actuator clutch (C) and rotate the shaft until the shaft arrow is in the vertical position. The damper blade will be fully open.
9. Loosen the adjustment stop (G) on the right side of the actuator and move it until it touches the drive stop on the locking collar and tighten.
10. See wiring instructions on last page of this manual.

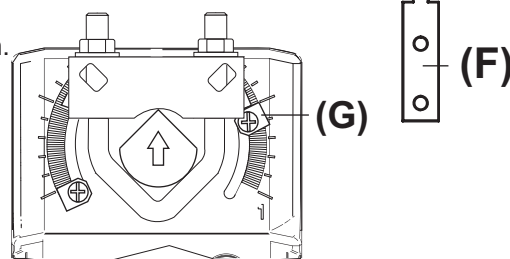
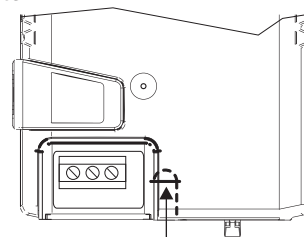
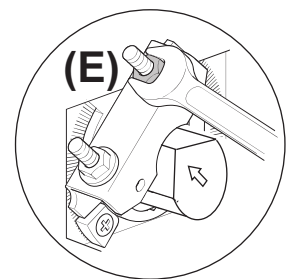

MOUNTING INSTRUCTIONS FOR RECTANGULAR SIDE MOUNT, SLIDE-IN DAMPERS

1. The RETRO-CPL-CAR-DMPR shaft adapter is required for mounting the actuator to a rectangular side mount, slide-in damper.
2. Since the damper shaft rotates 90°, it will not be necessary to adjust the actuator mechanical adjustment stops unless minimum position is required.
3. The damper blade shaft has two flat surfaces in the shape of a 'V'.

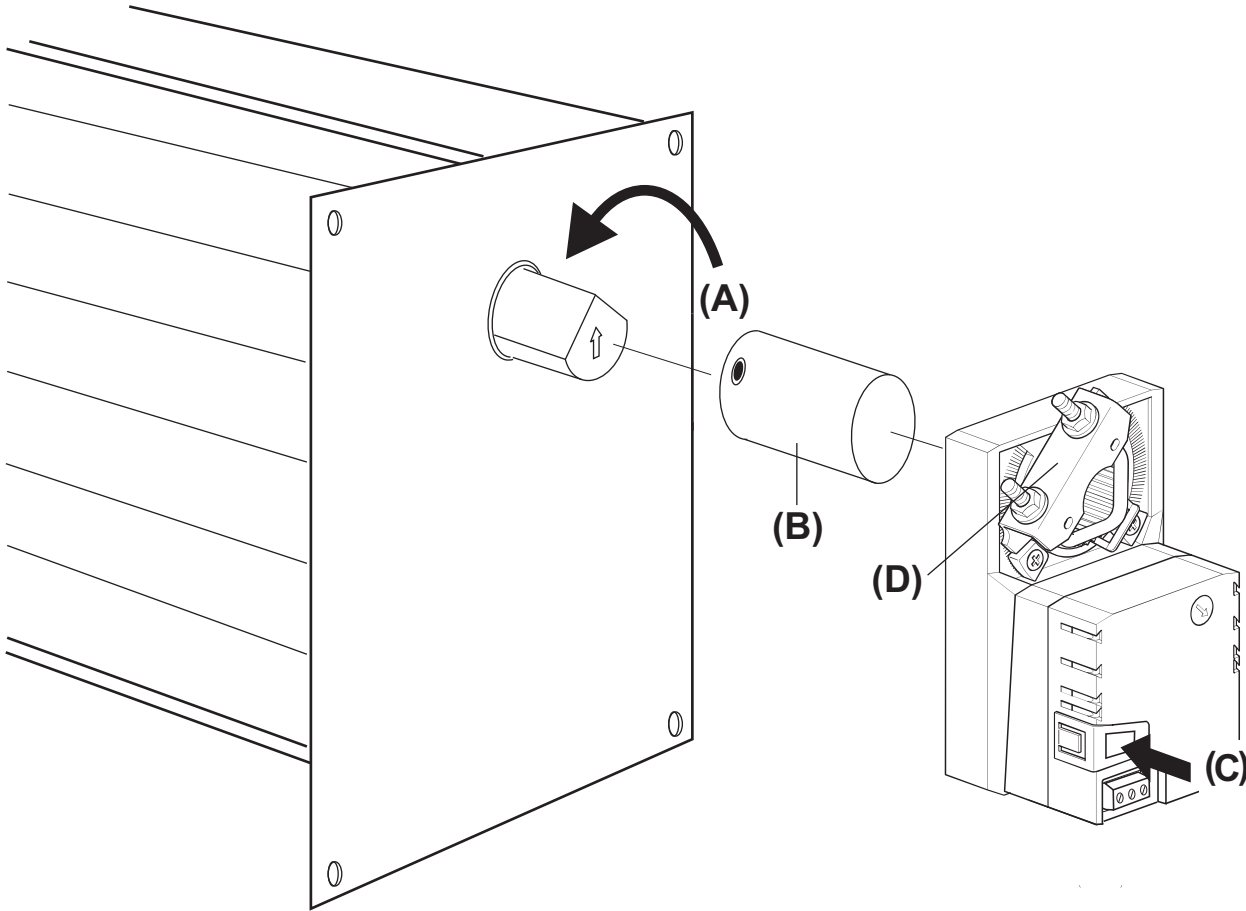

4. Rotate the damper shaft (A) counter clockwise until it comes to a stop.
5. Slide the shaft adapter (B) over the damper shaft so that the set screw is located on one of the flat surfaces. Use a 3/32" Allen wrench and securely tighten the shaft adapter to the damper shaft.
6. Push in on the actuator clutch (C) and rotate the collar (D) counter clockwise until it hits the mechanical adjustment stop.
7. Slide the actuator over the shaft adapter and evenly tighten the two nuts located on the actuator locking collar (E) making sure the shaft is stopped in the counter clockwise position and that the actuator is parallel with the damper mounting plate.
8. Once the locking collar is firmly tightened over the shaft, slide the universal mounting bracket (F) into the slot on the bottom of the actuator and mark the mounting holes. Use a 1/8" drill bit and drill two pilot holes. Use a Philips screw driver and carefully secure the mounting bracket using the two Philips Pan type F screws. **Do not over tighten the screws or they could stip out the thin metal back plate.**
9. See wiring instructions on last page of this manual.

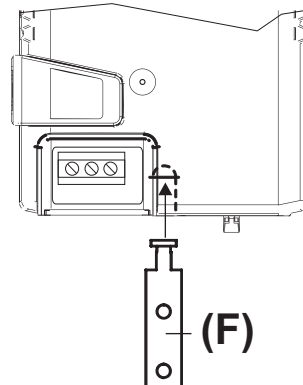
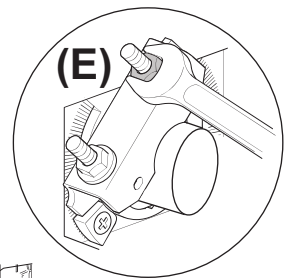

MOUNTING INSTRUCTIONS FOR RECTANGULAR BOTTOM MOUNT DAMPER

1. The RETRO-CPL-CAR-DMPR shaft adapter is required for mounting the actuator to a rectangular bottom damper.
2. Rectangular bottom mount dampers have a single blade and do not open and close on 90° rotation. The actuator has mechanical adjustment stops that can be used for minimum and maximum position settings.
3. The damper blade shaft has two flat surfaces in the shape of a 'V'.

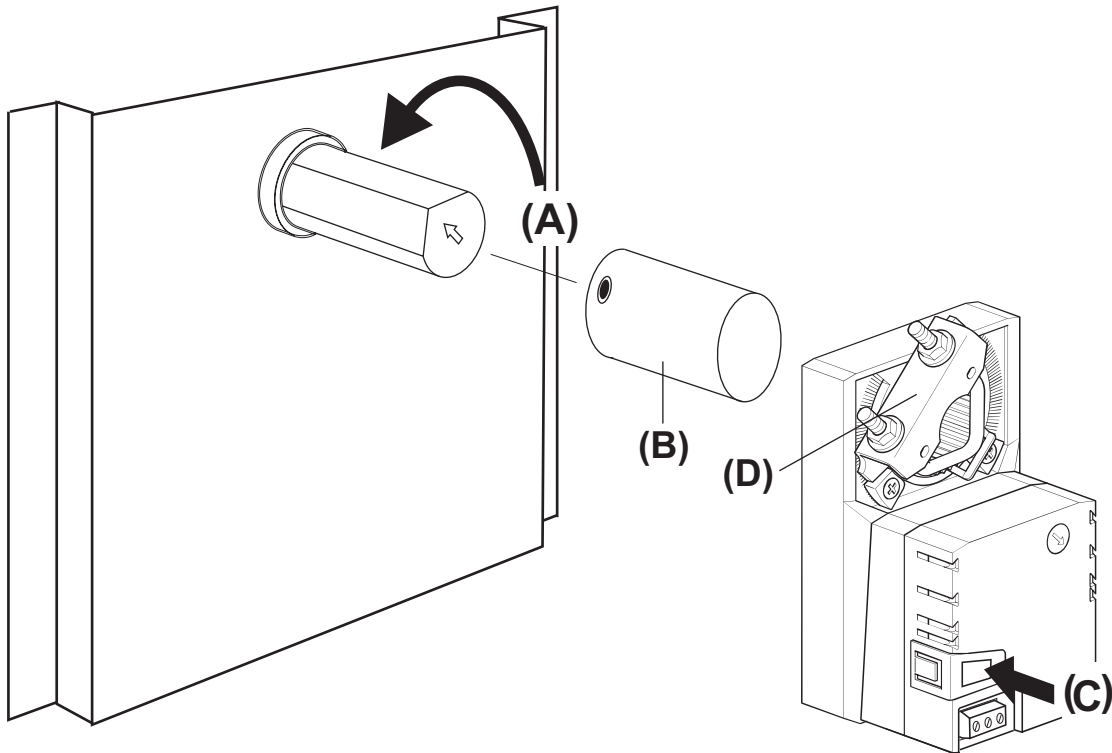

4. Rotate the damper shaft **(A)** counter clockwise until it comes to a stop.
5. Slide the shaft adapter **(B)** over the damper shaft so that the set screw is located on one of the flat surfaces. Use a 3/32" Allen wrench and securely tighten the shaft adapter to the damper shaft.
6. Push in on the actuator clutch **(C)** and rotate the collar **(D)** counter clockwise until it hits the mechanical adjustment stop.
7. Slide the actuator over the shaft adapter and evenly tighten the two nuts located on the actuator locking collar **(E)** making sure the shaft is stopped in the counter clockwise position and that the actuator is parallel with the damper mounting plate.
8. Once the locking collar is firmly tightened over the shaft, slide the universal mounting bracket **(F)** into the slot on the bottom of the actuator and secure using two (2) #8 x 1/2" Hex Washer Self-Tapping Tek Screws.
9. When the actuator is secure, push in on the actuator clutch **(C)** and rotate the shaft until the actuator locking collar is level with the top of the actuator. The damper blade will be fully open.
10. Loosen the adjustment stop **(G)** on the right side of the actuator and move it until it touches the drive stop on the locking collar and tighten.
11. See wiring instructions on back page of this manual.

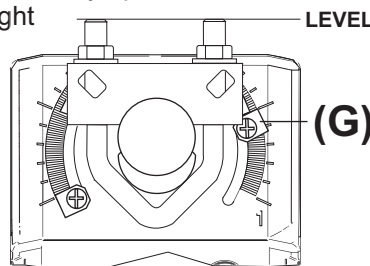
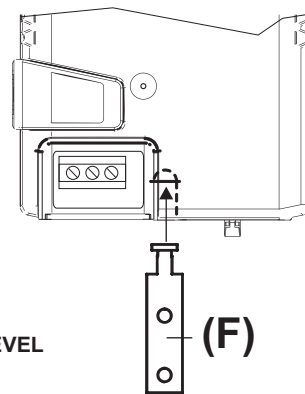
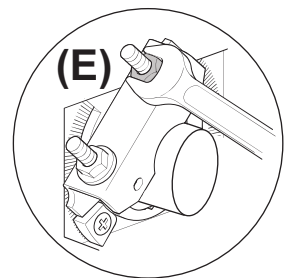

WIRING INSTRUCTIONS:

The CD-MOTOR-24 has dedicated screw terminals that accept conventional 18 gauge solid copper thermostat wire. The actuator rotation switch **(H)** is factory set to close on counter clockwise rotation and open on clockwise rotation which is compatible with this instruction manual.

Terminal designations are imprinted on the front of the actuator for easy reference.

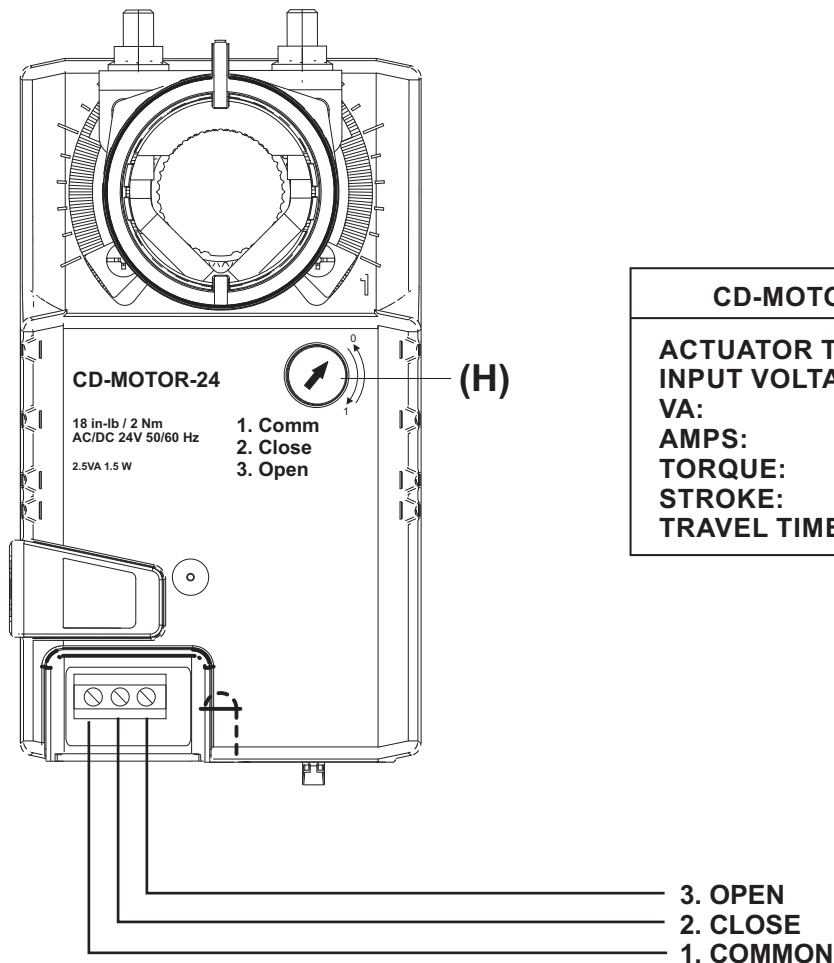

CD-MOTOR-24 SPECIFICATIONS	
ACTUATOR TYPE:	3-Wire Floating Point
INPUT VOLTAGE:	24VAC
VA:	2.5
AMPS:	.06
TORQUE:	18 in-lb
STROKE:	90° (Adjustable)
TRAVEL TIME:	15 Seconds @ 90°

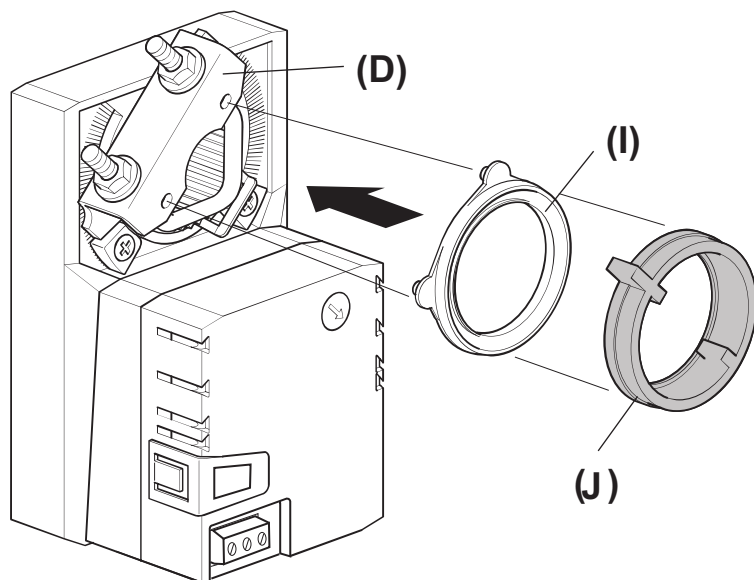

DAMPER POSITION INDICATOR:

The CD-MOTOR-24 has an adjustable 2-piece damper position indicator that can be removed while installing the actuator.

1. The black plastic ring **(I)** snaps into the actuator locking collar **(D)**.
2. The orange actuator position ring **(J)** snaps into the black plastic ring and can be rotated to any position.