

# RAVTRANS1CO

## 1st Company VTAC Transition Plenum for V10, V11 & V12 series

- Fully integrated retrofit solution for most 1st Company and Amana VTAC plenums
- Includes all necessary hardware except RAVDPLAT to be ordered separately
- Drain plumbing included
- Works with V10, V11, and V12 models
- Make up Air Ready with optional Make up Air Port for V12 models
- Heavy duty galvanized steel powder coated construction
- UL listed
- Designed to work with 1st Company and Amana plenums that are 21 3/8" W x 43 3/4" H x 5" to 20" deep

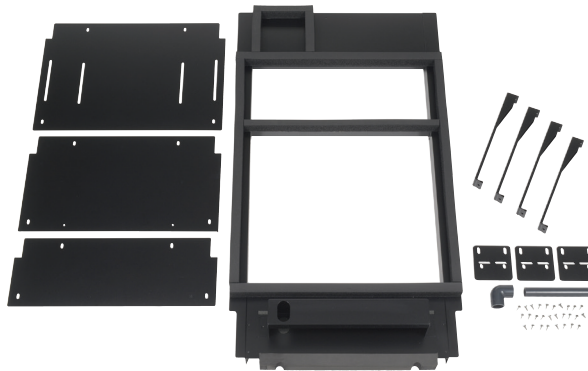

### Parts Included:

- Transition Plenum Adaptor
- 3 mounting brackets
- 4 air diverter support legs
- 3 piece variable depth air diverter
- All necessary screws
- 90° PVC elbow
- 7" PVC drain tube

Part Number	RAVTRANS1CO
Description	1st Company VTAC Transition Plenum
UPC Number	084691942566
Color	Black
Material	G60 Galvanized Painted
Product Width	23
Product Height	42.75
Product Depth (Adjustable)	5.84
Product Weight Net	28
Cut out Dimension	43 3/4" H x 21 3/8" W
Packed Width	24
Packed Depth	46
Packed Height	7
Packed Weight Gross	28.5
Overpack	Yes - Palletized
Number of Product per Overpack	12
Overpack Height (inc. pallet)	48
Overpack Width	48
Overpack Depth	46
Overpack Weight	350

